

Thank you for purchasing the **Parallel Desk**. This page lists all the contents included in the box. Please take time to identify the hardware as well as the individual components of this product. As you unpack and prepare for assembly, place the contents on a carpeted or padded area to protect them from damage.

Note: 2 people are required to safely assemble this product.

HARDWARE



8 - allen head screws



6 - wood screws

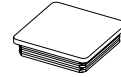

8 - tube caps



6 - washers

Missing hardware? Please call **800.606.6387** for replacements.

TOOLS REQUIRED

Allen wrench (included)

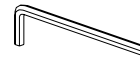

Phillips head screwdriver

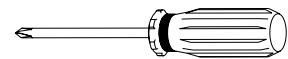

Hammer

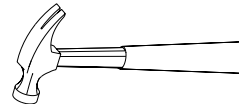

COMPONENTS

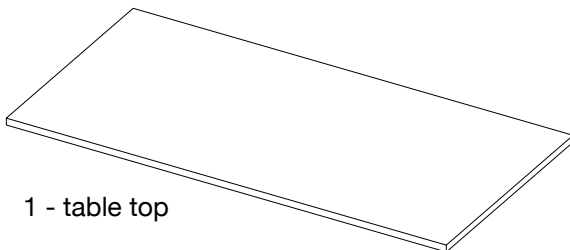

1 - table top

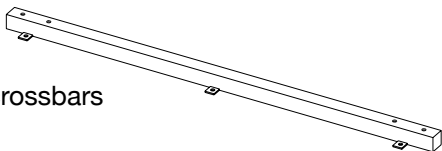

2 - crossbars

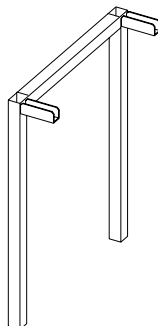

2 - leg frames

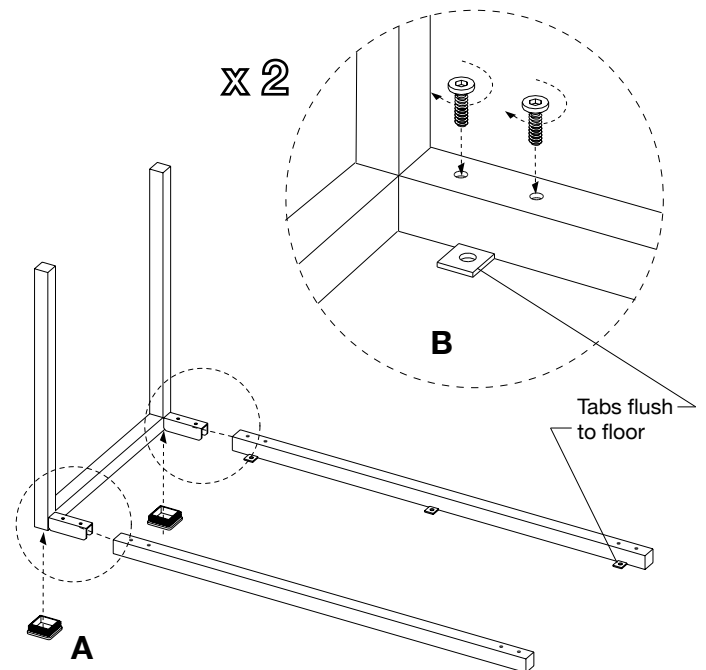

- ① A. Insert 1 **tube cap** into the top of each leg.
- B. Position 1 **leg frame** as shown and fit brackets into open tube ends of the 2 **crossbars**. Make sure tabs of crossbars are positioned as shown, flush with the floor.
- C. Align holes in brackets with holes in cross bars and loosely attach with 2 **allen head screws**. Do not fully tighten screws.

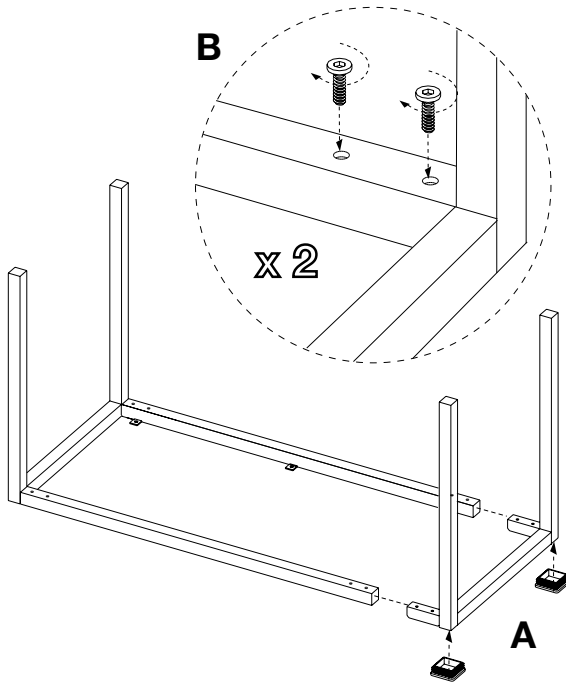

- ② A. Insert 1 **tube cap** into the top of each leg in the remaining **leg frame**.
 B. Attach leg frame using same method as in Step 1. Secure each crossbar with 2 **allen head screws**. Do not fully tighten screws.

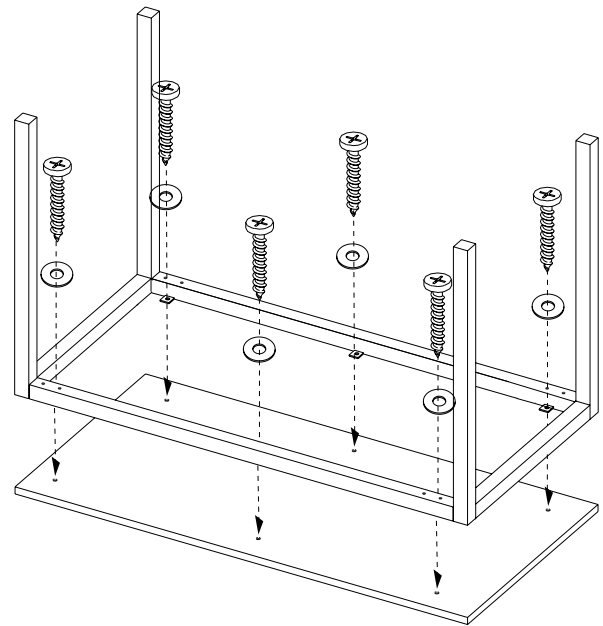

- ③ Position frame assembly onto table top, aligning holes in tabs with pre-drilled holes in table top. Using a **phillips head screwdriver**, secure each tab with 1 **wood screw** and 1 **washer**.

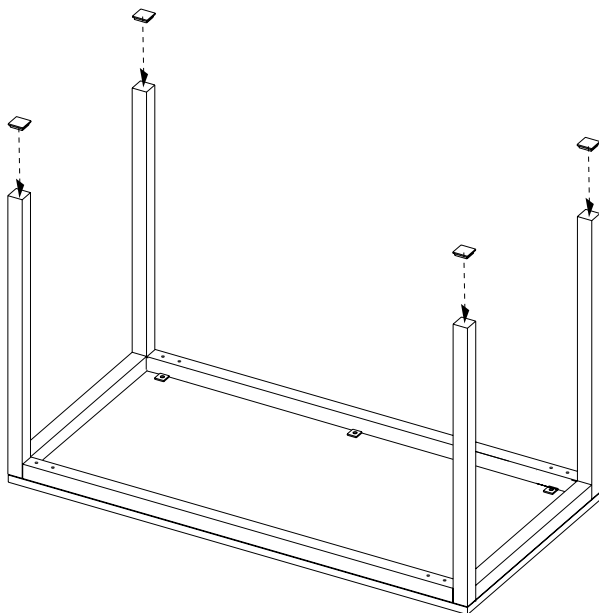

- ④ Insert 1 **tube cap** into the open end of each leg. If necessary, gently tap each tube cap into position with a **hammer**.

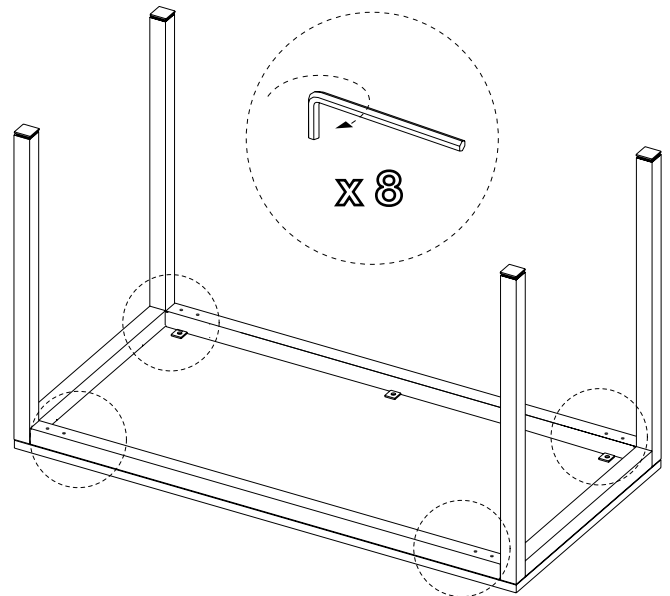

- ⑤ At this point, fully tighten all 8 **allen head screws** with the **allen wrench**. Assembly is now complete.

CLEANING AND CARE

Clean surfaces with a dry or damp soft cloth. Do not use abrasive cleaners. Do not use furniture wax or polish as the wood is finished with a protective clear lacquer.