

CREATIVE

**Sound**  
BLASTER

**EVO** zXR



**User's Guide**  
Model No.: GH0250



# Congratulations!

Thank you for choosing the Sound Blaster EVO ZxR entertainment headset.

The Evo ZxR is a headset with advanced audio processing on the go! With the built-in SBAXx-1 chip, the Evo ZxR meets the needs of today's mobile consumers by enhancing compressed audio from online sources.

It's wireless too; NFC makes pairing your smart device with the Evo ZxR via *Bluetooth* amazingly easy. Beyond that, the beam-forming dual microphone array guarantees crystal clear communication in any environment.

The EVO ZxR also comes with ANC or Active Noise Cancellation, which is really helpful on an airplane for cancelling out the rumble of the engines, so you can listen to your music or watch a movie and still get a great audio experience. The Talk Through feature on the other hand allows you to have a conversation without taking off your headset.

## Package Checklist

Your Sound Blaster EVO ZxR package comes with the following:

- The Sound Blaster EVO ZxR
- MicroUSB-to-USB cable - Length: 1.8m (5.91ft)
- 4-pole analog cable - Length: 1.2m (3.94ft) plus splitter adapter 0.6m (1.97ft)
- USB power adapter and plugs
- Airplane adapter
- Travel carry case
- Quick Start leaflet

## Minimum System Requirements

- Intel Core™2 Duo processor 2.2 GHz, AMD Athlon 64x2 Dual Core or equivalent processor
- Microsoft® Windows® 8 64-bit or 32-bit, Windows 7 64-bit or 32-bit, Windows Vista 64-bit or 32-bit; Macintosh OS X 10.5.8 and above
- 1GB RAM
- Powered USB 2.0/3.0 port

For Sound Blaster Central,

- iOS version 5.0 and above
- Android version 2.2 and above

### Note:

Due to programming changes, the recommended system requirements for the software and applications may change over time.

## More Help

For the latest news and products for the Sound Blaster, please visit [www.soundblaster.com](http://www.soundblaster.com). The site also includes information on making purchases, technical help and the latest software updates.

Alternatively, install the Sound Blaster Central mobile app. Explore the Resources page to find out more about Sound Blaster and your product.

### Using Creative Software AutoUpdate

Locating, downloading and installing updates for your Creative products is now simpler and faster with the web-based Creative Software AutoUpdate system.

When you connect to Creative Software AutoUpdate via the Internet, the website will analyze your computer system to determine your operating system, language and which Creative products are connected to your system.

When this analysis is completed, you will then be given a list of only the most relevant software updates for your connected products. The files can then be retrieved and installed.

To learn more about the Creative Software AutoUpdate, please visit [www.soundblaster.com/support](http://www.soundblaster.com/support).

### Notes:

First-time users of Creative Software AutoUpdate may be prompted to authorize the download of a browser component required for system analysis. Check to ensure that this content is signed by Creative Labs, Inc., then click the **Yes** button.

Please ensure that all your Creative products are connected and installed on the same computer running Creative Software AutoUpdate.

# Overview

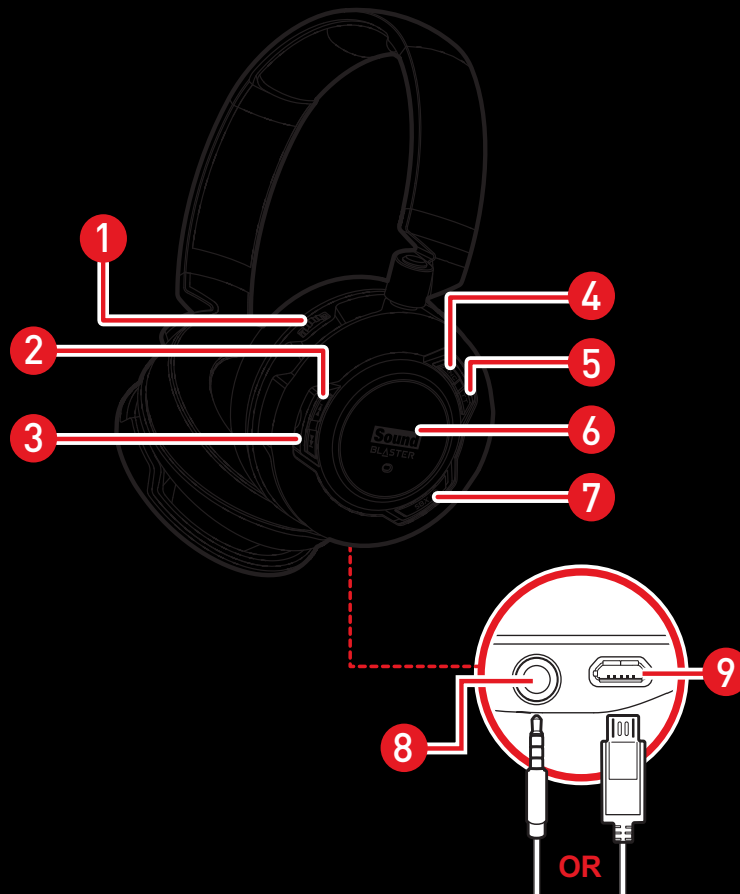

- 1 - Volume Control
- 2 - Next Track / Forward Button
- 3 - Previous Track / Rewind Button
- 4 - Power & SBX Button\*
- 5 - Active Noise Cancellation Button
- 6 - Talk Through Button
- 7 - Multifunction Button / NFC Zone
- 8 - 4-pole Analog Jack
- 9 - MicroUSB Port

\* Press and hold: Turns on/off the headset.

When playing music/movies: Activates/deactivates SBX Pro Studio

When making calls: Activates/deactivates CrystalVoice™ inNoiseReduction.

## Flexible Connection Options

Connect to your Smart Devices via *Bluetooth*

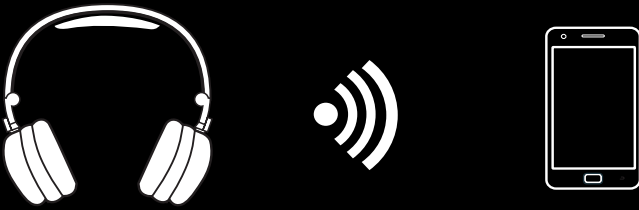

4-pole Analog Cable to your Smart Devices

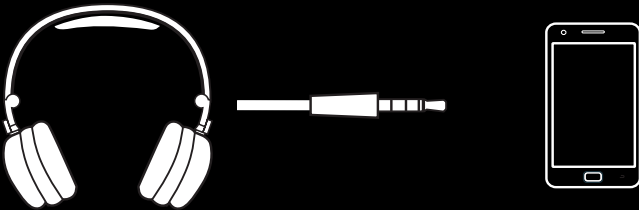

USB Cable to your PC/Mac

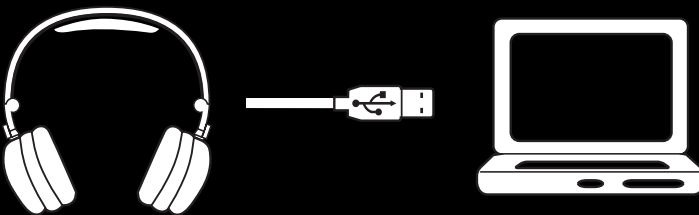

Splitter Cable to your Soundcard

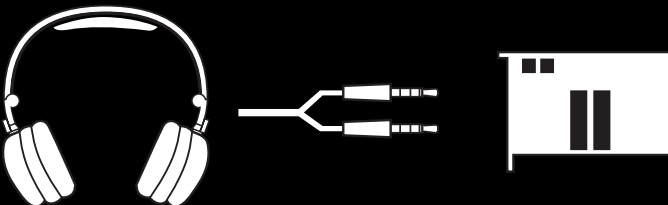

Airplane Adapter to an In-flight Entertainment System

[IMAGE PLACEHOLDER]

# Using Your Sound Blaster EVO ZxR

Set up your headset in four simple steps:

1. Charge your headset
2. Install the mobile app / software
3. Pair the headset with your NFC / BT devices **OR**
4. Connect the headset via USB cable / analog cable

## Step 1 : Charge your headset

You are recommended to charge your headset for 8 hours before it is used for the first time. Connect your headset to your computer using the MicroUSB-to-USB cable, or connect it to a power supply via an adapter (available separately). The LED flashes red when charging.

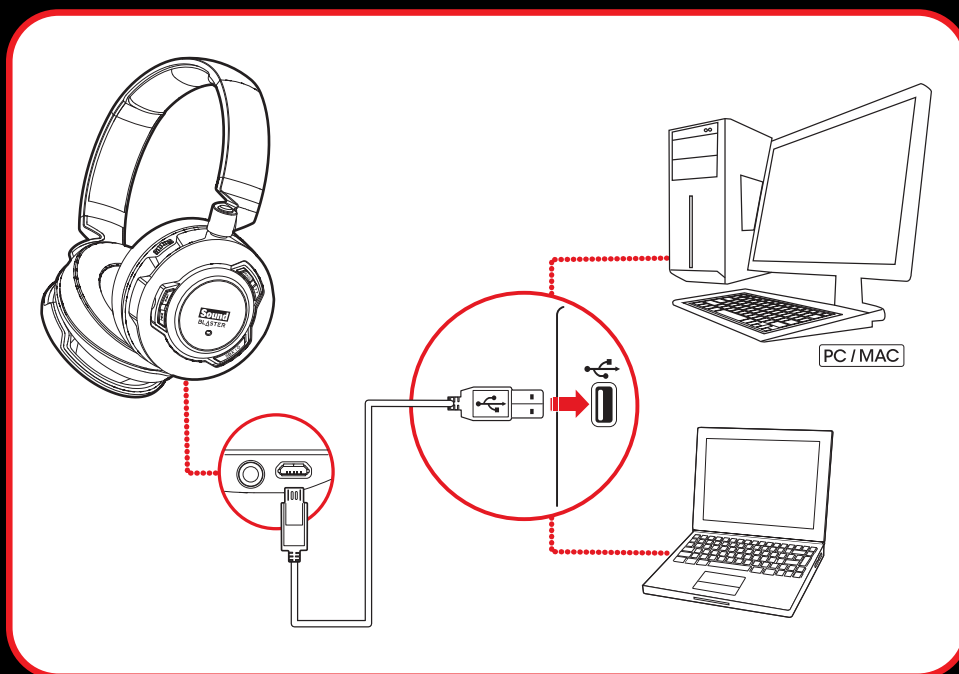

## Using Your Headset While Charging

During subsequent charges, you can use your headset while it charges. The LED will light in red while charging and return to its last status when fully charged.

You can also check the status of the battery via the battery indicator at the top right corner of the Sound Blaster EVO Control Panel. Please refer to **Using the Software** for details on this software.

### Note:

The low battery tone will start beeping to inform users of its status 15 minutes before the headset is completely powered off.

## Step 2 : Install the mobile app / software

### Sound Blaster Central mobile app

Sound Blaster EVO ZxRR comes with an amazing app, Sound Blaster Central, that supports both iOS and Android OS, so you can customize your audio – you now have total control right from the palm of your hand. Download Sound Blaster Central from the Apple App Store or Google Play Store.



## Sound Blaster EVO Control Panel

Your headset is now ready for use. However, you can enhance your audio and voice experience via an optional software package that can be downloaded and installed into your PC or Mac. We recommend that you download and install this software to make full use of all the features that your headset is equipped with.

### Note:

Please ensure that your headset is turned on and plugged into your computer before downloading and installing the software.

### For Windows

1. Using a standard web browser, visit [www.soundblaster.com/QSL/EVOZxR/](http://www.soundblaster.com/QSL/EVOZxR/) and locate the software package for the Windows operating system for your product.
2. Download this package into your local hard disk.
3. Locate and launch the software package.
4. Follow the on-screen instructions to complete the installation.
5. When prompted, restart your computer.
6. Launch the application by clicking **Start > Programs or All Programs > Creative > Sound Blaster EVO > Sound Blaster EVO Control Panel**.

### For Mac

1. Using your web browser, visit [www.soundblaster.com/QSL/EVOZxR/](http://www.soundblaster.com/QSL/EVOZxR/) and locate the software package for the Mac OS for your product.
2. Download this package into your local hard disk.
3. Double-click the downloaded file to decompress it.
4. Double-click the uncompressed DMG file.
5. Double-click the **Install** icon and follow the subsequent on-screen instructions to complete the installation.
6. Launch the **Sound Blaster EVO Control Panel** from the **Applications > Creative > Sound Blaster EVO** folder.

For more details on the software and the various features it has to offer, refer to **Using the Software**.



## Step 3: Pair the headset with your NFC / BT devices

### NFC Pairing

Bring your NFC-enabled device close (20mm) to the NFC zone / **Multifunction** button. The LED will light in blue for 3 seconds and a 3-note tone will be heard to indicate successful pairing. Play music from your device and experience superb audio realism and stunning 3D surround effects with the Sound Blaster Central.

If you wish to unpair the devices, simply tap your NFC device on the headset again.



### Note:

The headset is ready to use when the device displays "Sound Blaster EVO ZxR is connected" .

## Manual Pairing

### Step i: Activate pairing mode on the headset

Turn on your headset. If the headset has not been paired with any devices previously, it will go into *Bluetooth* discoverable mode. Otherwise, it will be automatically paired to previously paired devices.

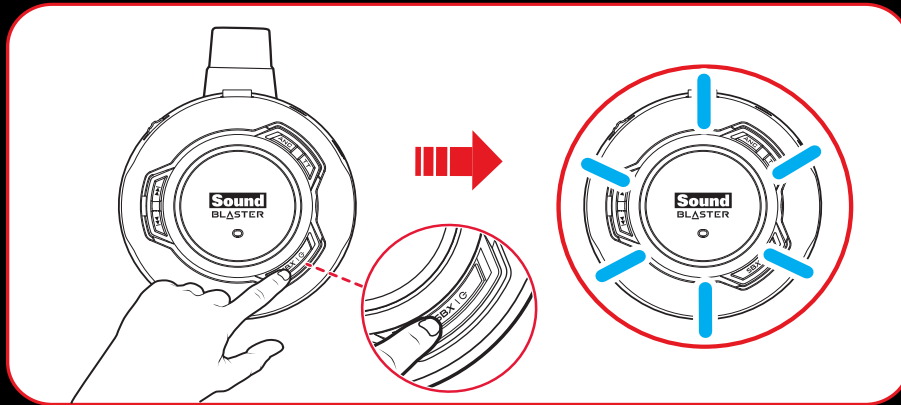

The *Bluetooth* discoverable mode is only available for 60 seconds after the headset is turned on. To activate *Bluetooth* again, press the **Multifunction** button for 5 seconds. The LED will begin to flash slowly in blue for 60 seconds while waiting to be connected.

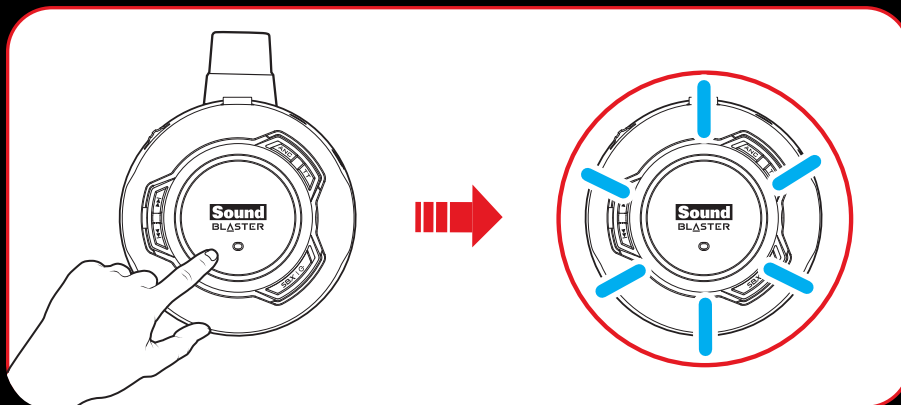

### Step ii: Activate pairing mode on your device

Activate *Bluetooth* on your smart device. From the list of discovered *Bluetooth* devices, select "SB EVO ZxR".

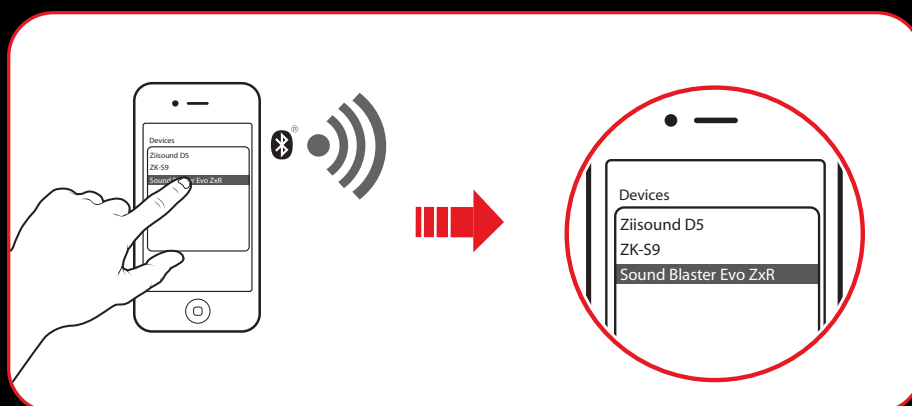

**Note:**

*Bluetooth* pairing between these devices may vary depending upon the model type. Consult your device's manual on how to pair.

**Step iii: Pairing success**

When the headset and the *Bluetooth* device are paired, the LED will light in blue for 3 seconds and a 3-note tone will be heard to indicate successful pairing before returning to its default / last status.

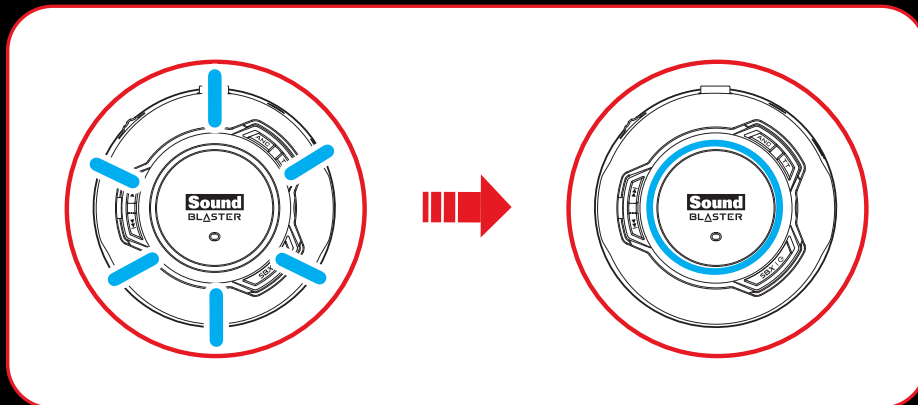

**Pairing Multiple Devices**

The EVO ZxR is able to pair up to two smart devices at the same time! To have the second device paired, repeat steps i to iii on **Manual Pairing**.

In the event a user wishes to pair the headset with a third smart device, one of the two devices that are currently paired with the headset has to be unpaired.

**Note:**

Only one of the devices is able to play music at one time. The last paired smart device takes precedence over the other device.

When there's an incoming call, the call takes precedence over audio playback -- music fades out and the ringtone will be heard.

## Step 4 : Connect the headset via USB cable / analog cable

### Connecting to a Computer (USB Digital Mode)

Connect your headset to a computer using the MicroUSB-to-USB cable. Turn it on by pressing the **Power & SBX** button. The LED will light in red once the headset is properly connected. Experience the power of Sound Blaster with all your games and calls, on your PC and Mac.

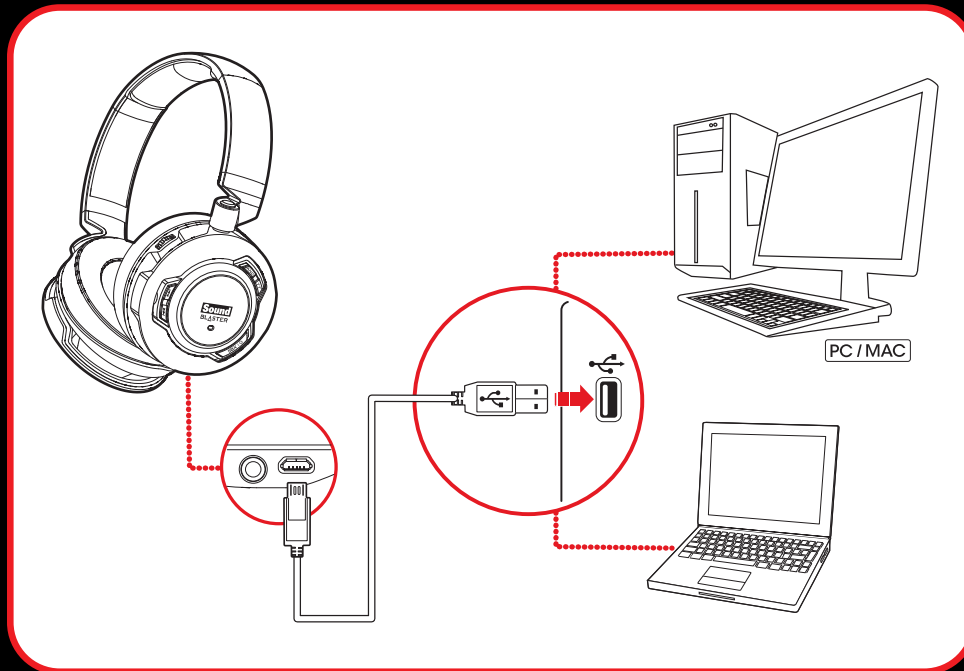

### Note:

Profile setting adjustments via Sound Blaster Evo Control Panel is only available in USB Digital Mode. Refer to **Using the Software** for more information.

### Set the default audio device (Mac OS ONLY)

1. Go to **System Preferences** and click **Sound**.
2. Select **Sound Blaster EVO ZxR** in both the **Output** and **Input** tabs.

## Connecting to a Computer (4-Pole Analog Mode)

To connect your headset to a sound card on your computer, simply connect it via the 4-pole analog cable using a splitter cable (included)

[IMAGE PLACEHOLDER].

## Connecting to a Mobile Device (4-Pole Analog Mode)

If your headset runs out of power, simply connect it to a mobile device via the 4-pole analog cable. Enjoy the power of the Sound Blaster EVO ZxR entertainment headset on-the-go with portable smart devices including iPhones, Android phones and tablets.

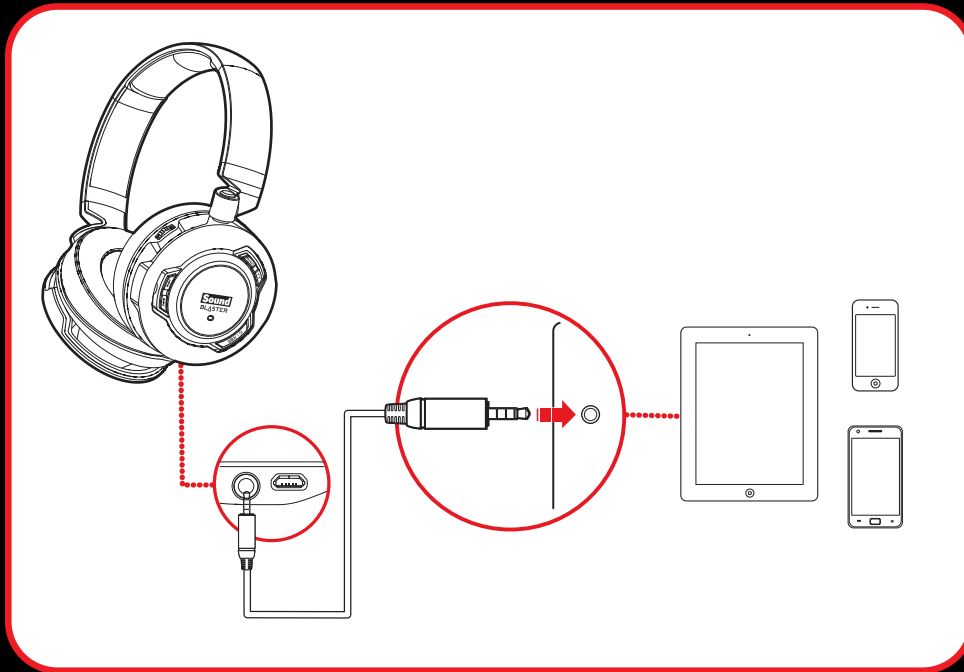

## Connecting to an In-flight Entertainment System (4-Pole Analog Mode)

Now you can enjoy the power of the Sound Blaster EVO ZxR headset even with an airplane's in-flight entertainment system. Simply connect your headset using the 4-pole analog cable to the in-flight entertainment system via an airplane adapter.

[IMAGE PLACEHOLDER]

## Use It

### Turn On the Headset

Press the **Power & SBX** button on the headset for 2 seconds to turn it on. Similarly, when it's turned on, press the **Power & SBX** button for 2 seconds again if you wish to turn it off.

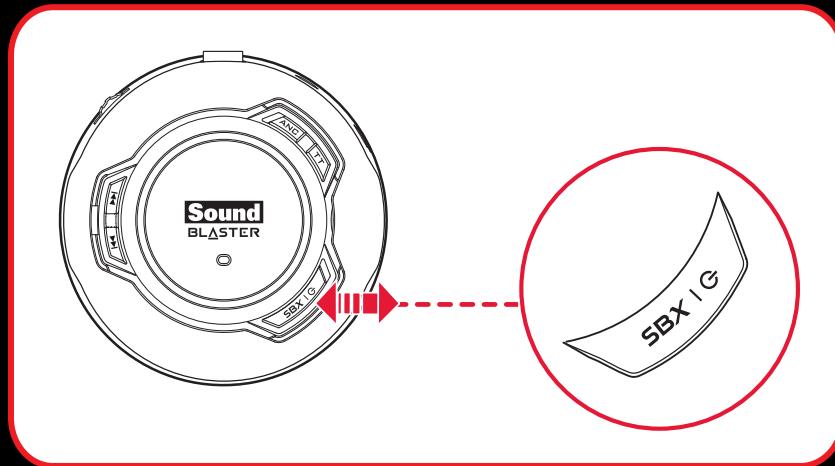

If your headset is paired successfully with a *Bluetooth*-enabled device previously, it will automatically search for the device when it's turned on. This gives you the convenience and freedom to move around a distance of 33 feet (10 meters) away from your *Bluetooth* device. The LED will flash slowly in blue while waiting to be connected.

No manual pairing is required by default. If you need to manually pair the headset such as when you use a new *Bluetooth* device or in the event of a connection error, refer to **Manual Pairing** for instructions.

#### **Note:**

If no pairing is done within 60 seconds, *Bluetooth* pairing mode will be deactivated.

The headset will automatically be powered off to conserve battery power if it has no activity for 15 minutes.



## Turn On/Off SBX Effect

When the headset is powered on, the SBX effect is being activated by default, and the green LED beside the **Power & SBX** button lights up. Simply press the **Power & SBX** button lightly during music playback or calls to activate different SBX features.

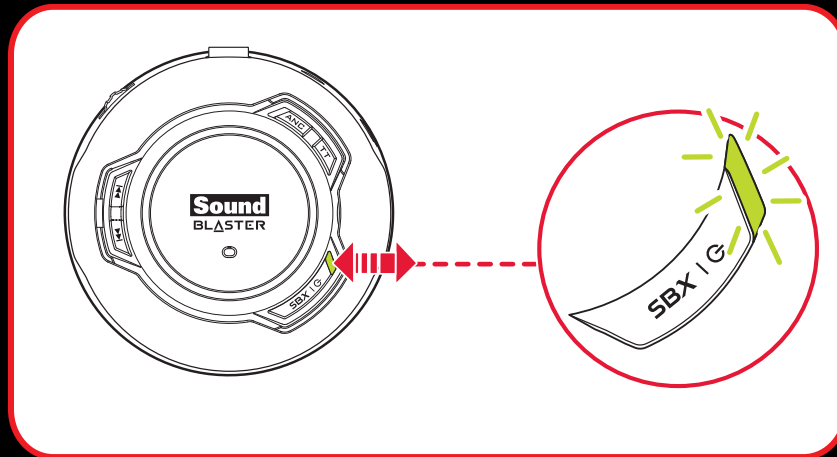

When you are playing music, press the **Power & SBX** button to turn on SBX. To select the your desired SBX Profile, e.g. Music, launch the Sound Blaster EVO Control Panel. Refer to **Using the Software**.

When you are in a call, press the **Power & SBX** button to activate CrystalVoice™ inNoiseReduction. CrystalVoice™ inNoiseReduction eliminates the other party's unwanted background noise so you can hear them clearly.

To turn off the SBX effect, simply press the **Power & SBX** button again.

## Wearing the Headset

Adjust the headband so that the headset rests lightly on your head. Do not tighten excessively.

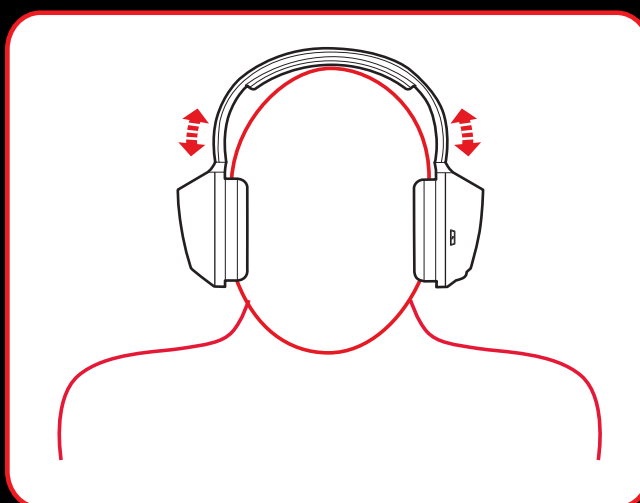

## Adjusting the Volume

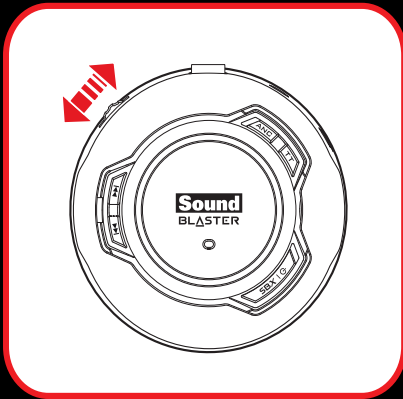

The Volume Control on the headset cup can be used to adjust your headset volume to a comfortable level. You can also adjust the volume via the software or the built-in volume settings on your computer.

### **CAUTION:**

Do not listen to audio on your headset at high volumes for prolonged periods of time to avoid impairing your hearing.

## Reset Headset to Factory Default Settings

Turn off your headset. Press and hold the **Multifunction** button followed by **Power & SBX** button for 1 second to reset *Bluetooth* pairings, SBX Pro Studio, CrystalVoice and volume level to their initial settings. A 3-note tone will be heard to indicate that the *Bluetooth* connections are all reset. The headset then returns to power on mode and ready for new *Bluetooth* pairings.

## Usage Scenarios

### Playing Music or Movies

Connect your Sound Blaster EVO ZxR wirelessly to portable entertainment devices such as mobile phones and tablets to enjoy Sound Blaster audio on the go! Alternatively, you may also connect it to your computer via USB to enjoy the legendary Sound Blaster audio quality.



The SBX Dialog Plus feature brings out the dialog in movies for maximum clarity, while the SBX Bass fills extends the low frequency tones and gives the extra impact for a dramatically improved sound experience. The SBX Surround enhances your movie or music playback by producing virtual speakers around, above and below you, creating an immersive audio experience.

#### 1. Play or Pause Music

Tap on the **Multifunction** button once to play music and again to pause it. Similarly, tap on the same button to resume.

#### 2. Fast Forward or Next Track

Press on the **Next Track / Forward** button once to skip a track. Continue pressing the button to skip a few tracks forward.

Press and hold the **Next Track / Forward** button to fast forward a track.

#### 3. Rewind or Previous Track

Press on the **Previous Track / Rewind** button once to go to the previous track. Continue pressing the button to skip a few tracks backwards.

Press and hold the **Previous Track / Rewind** button to rewind a track.

#### 4. Adjusting Volume

When listening to music, you may adjust the volume control to increase or decrease the music level.

**Note:** Not applicable in 4-Pole Analog Mode.

## Answering and Ending Calls

When the headset is turned on, it goes into standby mode and waits for calls passively. After you have ended a call on your mobile phone, the headset returns to standby mode or resumes your music again.

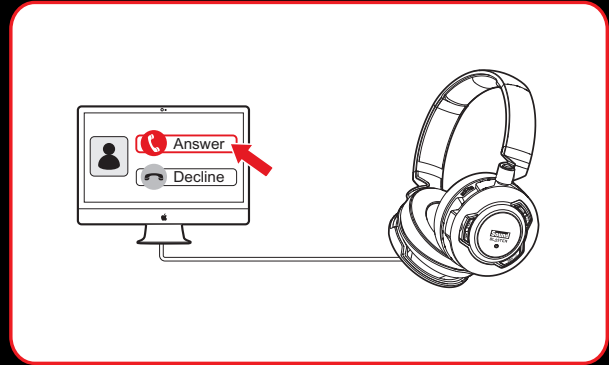

The CrystalVoice technology will be automatically enabled. The Voice Focus feature is able to pick up your voice clearly while the Noise Reduction effect eliminates unwanted background noise from both ends of a call. You may choose to morph your voice with special effects with the Voice FX too!

### 1. Answer or End a Call

When there's an incoming call from your mobile device while you are listening to music, the music fades out and the ringtone will gradually be heard.

Tap on the **Multifunction** button once to answer the call, and tap on the same button again to end it. The music will resume after the call has ended.

If the headset is connected to a computer, click on the answer call button prompted on the computer screen to enter voice communication.

### 2. Redial Last Number

Press the **Multifunction** button twice to redial the last called number.

**Note:** This feature may vary depending on your phone and is not available in USB Digital Mode.

### 3. Activate Voice Command

To activate voice command (e.g. Siri), press and hold the **Multifunction** button for 3 seconds to initiate the function.

**Note:** This feature may vary depending on your phone and is not available in USB Digital Mode.

## Using with In-flight Entertainment System

The Sound Blaster EVO ZxR is specially designed to give you an amazing audio experience when you are flying in the air. Besides having advanced audio processing, the Active Noise Cancellation feature further enhances your listening experience while Talk Through gives you greater convenience.

### **Amplify clarity with Active Noise Cancellation**

Activate ANC to cancel out background noise for a cleaner audio experience. This is great especially on flights, where you can cancel out the constant rumbling of airplane engine noise.

[IMAGE PLACEHOLDER]

### **Engage Conversations with Talk Through**

Activate Talk Through to have a conversation without taking off your headset. This is handy for talking to flight attendants while sparing you the hassle of taking your headset off and putting it back on a moment later.

[IMAGE PLACEHOLDER]

# Using the Software

A specialized software for the Sound Blaster EVO ZxR is developed to provide additional enhancements to the audio and voice inputs and outputs of the product. The software bundle supports a range of operating systems including:

- Windows 8, Windows 7, Windows Vista
- Mac OS X 10.5.8 or higher
- iOS v5 or higher
- Anroid v2.2 or higher

To take full advantage of your headset, we recommend downloading and installing this software into your computer. The following applications are included in the software bundle:

For **Windows OS**,

- Sound Blaster EVO Control Panel
- Creative Software AutoUpdate
- Product Registration
- Creative System Information
- Creative ALchemy
- Host OpenAL
- Creative Driver

For **Mac OS**,

- Sound Blaster EVO Control Panel
- Product Registration
- Creative Uninstaller
- Creative Driver

For **iOS** and **Android**,

- Sound Blaster Central

## **Note:**

Some applications are available only for certain operating systems. To learn more about each application, please consult its respective Online Help.

Launch the **Sound Blaster EVO Control Panel**.



This software includes a number of configurations that help you control the basic functions of your product plus several software enhancement configurations that can be made to heighten your product's performance. Click each of the menu bars to expand the configurations available.

## Using the Sound Blaster EVO Control Panel

The rest of this chapter explains how to use the Sound Blaster EVO Control Panel to view and adjust the various features of your Sound Blaster EVO ZxR. The examples and screenshots below uses Windows as an example. The user interface for other operating systems may differ slightly.

### Managing Your Profiles

The Sound Blaster EVO Control Panel comes equipped with a set of pre-configured profiles to suit your different needs including:

- Music
- Movies
- Games

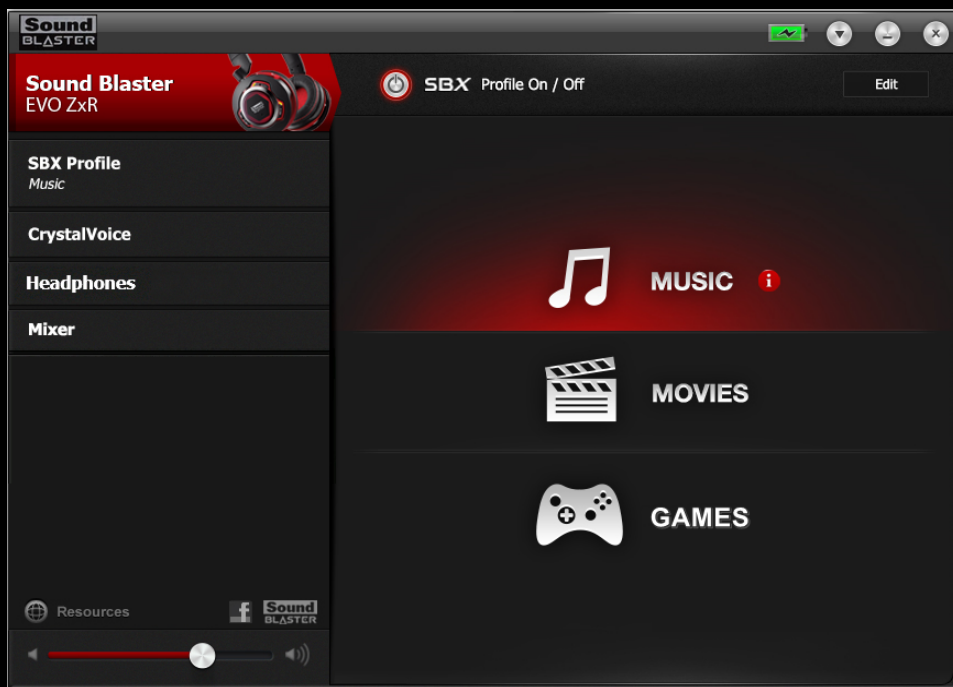

To activate a profile,

1. Click the **SBX Profile** menu to view the **SBX Profile** screen.
2. Select your desired profile from the screen.

To modify and save changes to the active profile,

1. Click the **Edit** button to modify the profile you have selected.
2. Navigate through the various other menu options of the Sound Blaster EVO Control Panel and modify the configurations as desired.



## Configuring your general settings

You can change the language settings or restore settings to their default values.



Click  from the top right corner of the interface and select the option from the list.

The battery icon  indicates the battery status of the headset.

## Enhancing the Audio - SBX Pro Studio

To configure SBX Pro Studio, go to the **SBX Profile** screen, select a profile and click **Edit** to enter the **SBX Pro Studio** screen. By default, the SBX effect is turned on. You may adjust the effects on this screen.



1. Click the checkbox next to one or more of the available enhancements to enable it.
2. Adjust the level of enhancements to be applied individually.
3. Click  to play the demo video to test your configurations.
4. Readjust if necessary.
5. Click **Save** to save the adjusted settings or **Reset** to restore default settings.

SBX Pro Studio includes a number of enhancements for movies and gaming, elevating your movie and gaming experience to the next level. These include:

- **SBX Surround** - provides immersion control to enhance the natural sense of audio depth and spaciousness by creating virtual surround sound channels. Stereo content or multi-channel content will sound as if its coming from all sides while voices remain centered in front and original balance and timbre is preserved.
- **SBX Crystalizer** - restores the natural dynamic range that is lost when music files (e.g. MP3) gets compressed. This makes the music sound as good as the artist originally intended, and adds an enhanced level of realism for movies and games.
- **SBX Bass** - fills in the missing low frequency tones and gives the extra impact for a better entertainment experience. Consumers no longer have to tolerate a lack of bass in speakers as the SBX Bass technology dramatically improves the sound experience even in the absence of a subwoofer.
- **SBX Smart Volume** - addresses the problem of abrupt volume level changes during playback and between songs by continuously measuring volume automatically, applying gain and attenuation intelligently to compensate for any changes.
- **SBX Dialog Plus** - enhances the voices in movies for clearer dialog, allowing the listener to hear the dialog over the rest of the soundtrack and over ambient noise in the listening environment.

## Enhancing the Microphone - CrystalVoice™

To configure CrystalVoice settings, click the **CrystalVoice** menu option on the left.



1. Select a recording device and adjust its microphone volume using the volume slider.
2. Click the checkbox next to one or more of the available enhancements to enable it.
3. Click **Test** and speak into your microphone to listen to your voice with the selected presets applied. Readjust if necessary.

CrystalVoice enhancements helps you hear and be heard clearly by all participants of the conference, doing away with noisy background distortions and unclear communication that disrupts your online chatting and gaming experience. The various enhancements available include:

- **CrystalVoice FX™** - enables the alteration of voice with a variety of effects which can be used to enhance the tone of a voice, create interesting accents or even allow someone to sound like a completely different person.
- **CrystalVoice Noise Reduction** - enables the speaker to be heard clearly over background noise by constantly monitoring the environment and eliminating unwanted noise that interferes with the conversation.
- **CrystalVoice Focus** - creates a zone and suppresses noise outside it to enable the speaker within to be heard with amazing clarity. Multiple microphones are used to focus, enhance the speaker's voice, and eliminate sounds outside the zone.
- **CrystalVoice Incoming Call Noise Reduction** - eliminates echoes and enables the speaker to listen to the other parties clearly. Echoes are a common problem present in voice communication systems that disrupts conversations by making it difficult to hear the other party.

### Note:

The **CrystalVoice Focus** and **CrystalVoice Incoming Call Noise Reduction** features will be turned on automatically at all times.

## Equalizer Settings

Equalizers allows you to filter various audio frequency, thus controlling the tone of your audio output. The Sound Blaster EVO Control Panel comes equipped with a range of preset equalizer settings, helping you to select different audio tones easily. You can also manually modify or add equalizer presets.



To configure Equalizer settings, go to the **SBX Profile** screen and select a profile. Click **Edit** and then click **Equalizer**. To apply and adjust an equalizer preset,

1. Check the **EQ** checkbox to enable the use of the equalizer.
2. From the drop down menu, select the preset to use.
3. Adjust the vertical slider bars to achieve your desired level.
4. Click **Save** to save the changes to the active preset or to a new preset.

You can also delete any user created equalizer presets by selecting the preset from the drop down menu and clicking **Delete**.

### Note:

All default equalizer presets cannot be deleted.

## Headphones Settings

The Sound Blaster EVO Control Panel enables you to enjoy audio with 7.1 channel virtual surround sound from your EVO ZxR.

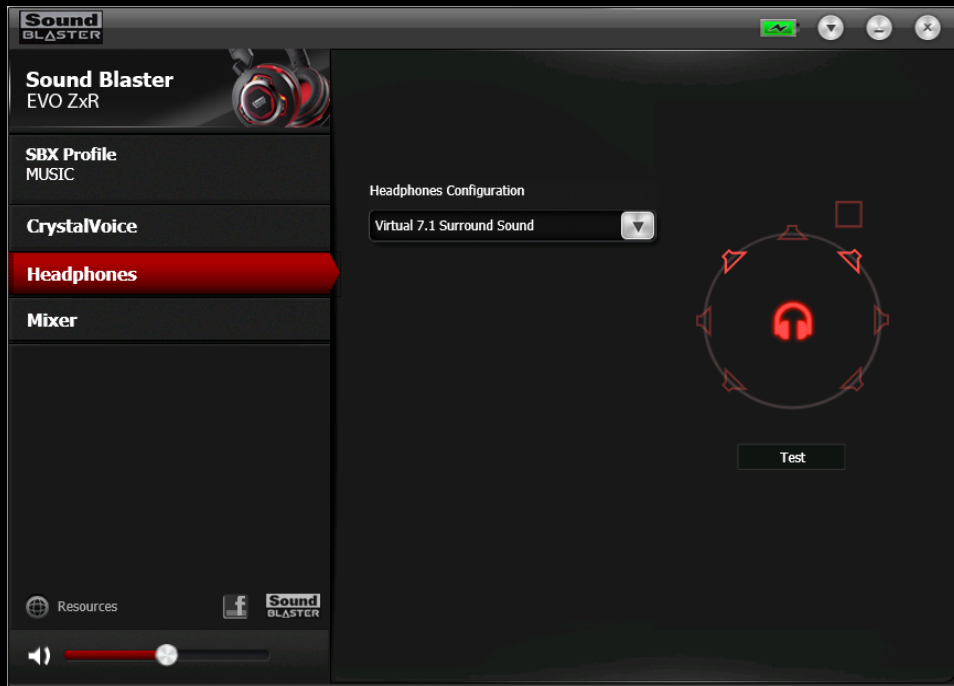

**Note:**

Click **Test** to listen to audio with the selected configuration.

## Mixer Settings

A mixer is also available via the software, allowing you to adjust the volume levels of individual outputs and channels including the microphone, headphones, etc. Simply click the **Mixer** option on the menu and adjust the volumes using the sliders.



## Playing Games

Your headset is equipped with cutting edge audio technologies and software to enhance the audio in your games. SBX Pro Studio will elevate your gaming experience to the next level, allowing you to hear sound details in games you have never heard before! For more details on the various SBX Pro Studio effects and their setup, please refer to **Enhancing the Audio - SBX Pro Studio**.

## Restoring Audio Effects in Games with Creative ALchemy

When playing DirectSound<sup>®</sup> 3D on Windows 8, Windows 7 and Windows Vista, the game loses its immersiveness and environmental effects due to changes in audio architecture.

To restore these effects and experience the full audio immersion, follow the steps below:

### Enable the game in Creative ALchemy

1. Click **Start > Programs or All Programs > Creative > ALchemy > Creative ALchemy**. The game should be detected automatically and appear in the left column.
2. Select the game and click **>>** to move it to the right column.
3. Close the application.

When you launch the game, you should hear the original effects.

### Note:

If the game is not detected, do the following:

- Navigate to the folder where you have installed the game.
- Right-click the game's launched and select **Run as administrator**.
- Exit the application and launch Creative ALchemy again. The game should now appear in the left column.

# General Specifications

## Connectivity

- 3.50mm (1/8") 4-pole jack for connection to mobile devices
- Micro USB port for charging and connection to computers
- *Bluetooth*
- NFC

## Technical Specifications

- *Bluetooth* Version: *Bluetooth* 2.1 + EDR (Enhanced Data Rate)
- *Bluetooth* Operating Frequency: 2402 - 2480 MHz
- *Bluetooth* Operating Range: Up to 10 meters / 33 feet  
(Measured in open space. Walls and structures may affect range of device.)
- Supported *Bluetooth* Profiles:
  - A2DP (Wireless Stereo *Bluetooth*)
  - AVRCP (*Bluetooth* Remote Control)
  - HSP (Headset Profile)
  - HFP (Handsfree Profile)
- Supported Audio Codec: AAC, SBC, aptX
- Operating Temperature Range: 0°C to 45°C
- Number of RF channels: 79
- RF transmitter power output: 0dBm (typical)
- Lithium Ion Battery: 3.7 V 1500 mAh (5.55 Wh)
- USB Input: 5 V  500 mA

## SBX Pro Studio Technology

- SBX Surround
- SBX Crystalizer
- SBX Bass
- SBX Smart Volume
- SBX Dialog Plus

## CrystalVoice Technology

- CrystalVoice FX
- CrystalVoice Noise Reduction
- CrystalVoice Focus
- CrystalVoice inNoiseReduction



# Troubleshooting

## What do the various LED statuses mean?

The Sound Blaster EVO ZxR headset is equipped with LEDs that indicate the statuses of the device. Each LED, their possible statuses and corresponding explanations are listed in the tables below:

Action	LED	Status
Power On / Off	Solid red (with power up tone)	Headset is powered on
	Off (with power down tone)	Headset is off
Battery Charging (headset status is OFF)	Flashing slowly in red	Headset battery is charging
	Off	Battery charging is complete
Battery Charging (headset status is ON)	Solid red	Headset battery is charging
	LED returns to the last status	Battery charging is complete
Headset Pairing	Flashing slowly in blue (60 seconds)	Headset is searching for <i>Bluetooth</i> -enabled devices
	Solid blue (3 seconds) and returns to the last status	Headset is paired successfully
Unpair Headset	Flashing slowly in blue	Headset is unpaired

## The onboard audio chipset seems to be in conflict with Sound Blaster EVO ZxR.

Ensure that the Sound Blaster EVO ZxR headset is properly inserted into the USB port.

## No sound from the headset.

Check the following:

- The headset and the *Bluetooth* on your device are turned on.
- The headset has sufficient battery power.
- The volume settings in Sound Blaster EVO Control Panel and system audio are properly adjusted and not muted.
- There is no hardware conflict between the headset and a peripheral device.
- The headset is selected as the default audio device. Ensure that existing analog headset is disconnected.

## There is clipping/distortion during audio playback.

Check the following:

- Your computer system should be running in high performance mode. You may need to disable any power saving features.
- The music source may be distorted. Ensure that the music played has no distortion.
- Ensure that the software graphical equalizer or sound processing effects found in third party media players are disabled.

### Some features are disabled when playing certain games.

When playing games that use DirectSound3D or OpenAL sound engines, certain audio features will be disabled automatically. This is to avoid distorting the environmental audio cues present in the game. These features will be re-enabled automatically when you exit the game.

### Electronic interferences is occurring with other wireless devices.

Do the following:

- Set your wireless LAN router's channel to Auto, 1 or 11. To do this, refer to your router's user documentation.
- Place your *Bluetooth* device away from other devices (for example, wireless routers) that transmit wireless signals.
- Place your *Bluetooth* device away from large metal surfaces.
- Refrain from doing large file transfers via the wireless Internet or *Bluetooth* connection while listening to music wirelessly. Alternatively, do not use your headset during intensive file transfers.
- Disconnect existing *Bluetooth* device.

### Music is not being transmitted to my headset.

Check the following:

- Your *Bluetooth* device and your headset are turned on.
- Your *Bluetooth* device and your headset are paired with each other.
- For Android phone, launch "*Bluetooth* setting" and click on the headset device's name. Under "Profile", make sure both "Call audio" and "Media audio" are checked.
- Ensure that the headset is set as the default *Bluetooth* output device on mobile phones or tablets.

### Problem with NFC pairing.

Do the following:

- Check if your mobile device is NFC-enabled.
- Ensure that the NFC feature on your mobile device is turned on.
- Ensure that the Android OS on your device is updated to the latest version. An older version of Android might not be able to pair with audio device.
- Check if there are already two devices being connected to the headset. In that case, select one of the devices to be powered off.

## Additional guide for Windows users

In the event a user wishes to connect the headset via a 4-pole cable to a PC / notebook or a Sound Blaster sound card, it is recommended to use a Y-splitter for best audio. **Note:** Turn off the SBX effect on the headset if it's connected to the Sound Blaster sound card.

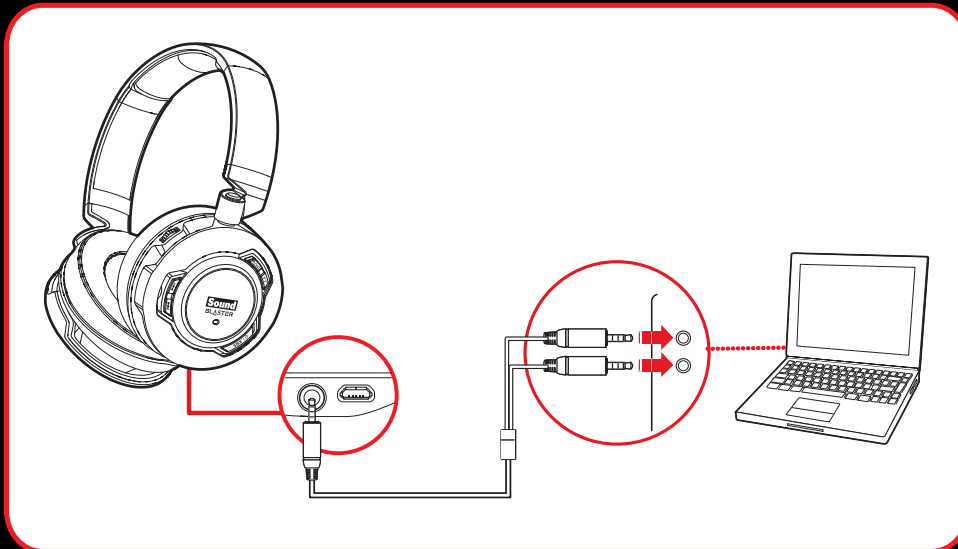

Generally a 4-pole stereo cable bundle allows you to connect your headset to your iPhone / Android phone / tablet. However, some phone / tablet's 4-pole female jack has different configuration and this cable is unable to support if the configuration is different from the jack (bundled) as illustrated below:

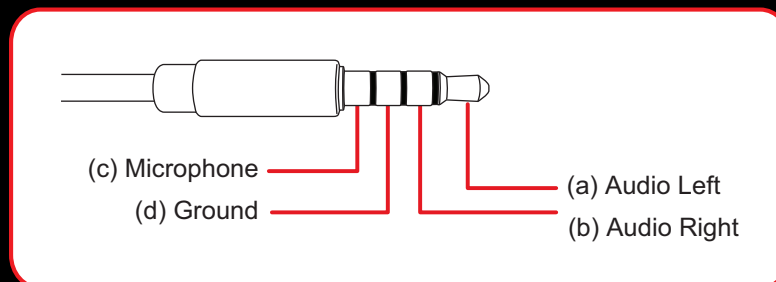

Should you be keen to connect your headset to an MP3 Player, you will need to check if the configuration of its 4-pole female jack is compatible.

## Tips for iPhone users

When your iPhone is paired with the EVO ZxR during a call, you have the option to switch the audio source to either the EVO ZxR or your phone, so you are able to speak on the desired device or headset.

**Note:** By default, the selected device will be your iPhone.

- a. To change the audio source, tap the "audio source" icon on the screen.



- b. Then, tap on the desired device, e.g. "SB EVO ZxR".



# Safety Information

Refer to the following information to use your product safely, and to reduce the chance of electric shock, short-circuiting, damage, fire, hearing impairment or other hazards. Improper handling may void the warranty for your product. For more information, read the warranty available with your product.

- Do not dismantle or attempt to repair your product.  
**Refer all servicing to authorized repair agents.**
- Do not expose your product to temperatures outside the range of 0°C to 45°C (32°F to 113°F).
- Do not pierce, crush or set fire to your product.
- Keep your product away from strong magnetic objects.
- Do not subject your product to excessive force or impact.
- Do not expose your product to water or moisture.  
If your product is moisture-resistant, take care not to immerse your product in water or expose it to rain.

## Wireless Product

- The short wave radio frequency signals of a wireless device may impair the operation of other electronic and medical devices.
- Switch off the device where it is prohibited. Do not use the device in medical facilities, aircraft, refueling points, close to automatic doors, automatic fire alarms or other automatically controlled devices.
- Keep this device at least 20 cm from pacemakers and other medical devices. Radio waves may impair the operation of pacemakers and other medical devices.

## Embedded Battery

- Do not attempt to remove the embedded battery.  
The product must be disposed of according to local environmental regulations. To replace the battery, return your product to your regional support office. For product service information, go to [www.creative.com](http://www.creative.com).
- Do not expose to excessive heat such as sunlight, fire or the like.
- **CAUTION:** Risk of explosion if battery is replaced by incorrect types.

## Earphones

- When a conductive apparatus, such as earphones, is used in close proximity with a CRT television or CRT monitor, the latter may emit an electrostatic discharge. This electrostatic discharge can be felt as a static shock. While this static shock is usually harmless, it is good practice to avoid close contact with CRT devices when using earphones.
- Do not listen to audio on your earbuds or headphones at high volume for prolonged periods of time as hearing loss may result. For users in the United States, go to [www.hei.org](http://www.hei.org) for more information.
- Do not listen to your audio device at high volume when driving, cycling or crossing the road, especially in heavy traffic or any other traffic condition where such use will hinder safe travel on the roads. We recommend that consumers be extremely cautious when using this device on the road.



## **Avoid Hearing Damage**

Permanent hearing loss may occur if the headphone is used at high volume. Set the volume to a safe level. You can adapt over time to a higher volume of sound that may sound normal but can be damaging to your hearing. If you experience ringing in your ears or muffled speech, stop listening and have your hearing checked. The louder the volume, the less time is required before your hearing could be affected. Hearing experts suggest that to protect your hearing:

- Limit the amount of time you use the headphone at high volume.
- Avoid turning up the volume to block out noisy surroundings.
- Turn the volume down if you can't hear people speaking near you.

## IMPORTANT — A LIRE AVEC ATTENTION

Ecouter de manière prolongée, à un très haut volume sonore de la musique (au dessus de 80 décibels), au moyen d'un casque ou d'écouteurs, peut entraîner une détérioration irréversible et définitive de vos facultés auditives. L'usage répété et habituel d'un casque ou d'écouteurs à un niveau de volume sonore trop élevé peut donner l'impression à l'utilisateur que le volume sonore émis par l'appareil n'est pas suffisant. L'utilisateur sera tenté d'augmenter, petit à petit, son réglage habituel, risquant ainsi d'atteindre un niveau dangereux pour ses oreilles. Afin de protéger votre santé, et vos oreilles, veillez à maintenir le volume de la sortie casque de votre appareil à un niveau adapté et à interrompre son utilisation régulièrement et particulièrement si des symptômes, comme des troubles de l'ouïe, se manifestent.

N'utilisez pas le casque ou les écouteurs pendant la conduite d'une voiture, d'une bicyclette ou de tout autre véhicule motorisé, afin d'éviter tout accident de circulation. En outre, il est interdit dans certains pays d'utiliser un casque ou des écouteurs en conduisant. Il peut être également dangereux d'écouter à volume élevé tout en marchant, spécialement aux passages piétons. Soyez toujours extrêmement prudent et cessez d'utiliser cet appareil dans les situations présentant des risques d'accident.

Evitez d'utiliser le casque ou les écouteurs à volume élevé. Les médecins spécialistes de l'audition déconseillent une écoute continue à volume trop élevé. Si vous percevez un sifflement dans les oreilles, réduisez le volume ou cessez l'écoute.

Maintenez un volume d'écoute modéré. Vous pourrez ainsi entendre les sons extérieurs et être attentif aux gens qui vous entourent.

Votre produit Creative accompagné des écouteurs fournis, est conforme à la réglementation française concernant les baladeurs musicaux (Arrêté du 24 Juillet 1998). Les caractéristiques techniques de ces écouteurs se trouvent dans le manuel en ligne et/ou sur le site internet de Creative. Si vous choisissez d'utiliser un autre casque ou d'autres écouteurs, veuillez vous assurer au préalable que leurs caractéristiques techniques soient les mêmes.

## срок эксплуатационной долговечности

В соответствии с законодательством Российской Федерации компания Creative устанавливает для данного товара срок службы 2 года. Указанный срок – это период времени, в течение которого компания Creative гарантирует возможность использования продукции в соответствии с ее назначением. Кроме того, во время этого срока компания Creative гарантирует:

(i) безопасность товара, (ii) возможность выполнения его ремонта и получения технической поддержки, (iii) поставку запасных частей. Однако установление срока службы не означает автоматического бесплатного предоставления технической поддержки и обслуживания. Эти виды услуг предоставляются бесплатно только в течение гарантийного периода в соответствии с гарантийными обязательствами.

# Regulatory Information

## Notice for the USA

**FCC Part 15:** This equipment has been tested and found to comply with the limits for a Class B digital device, pursuant to Part 15 of the FCC Rules. These limits are designed to provide reasonable protection against harmful interference in a residential installation. This equipment generates, uses and can radiate radio frequency energy and, if not installed and used in accordance with instructions, may cause harmful interference to radio communications. However, there is no guarantee that interference will not occur in a particular installation. If this equipment does cause harmful interference to radio or television reception, which can be determined by turning the equipment off and on, the user is encouraged to try to correct the interference by one or more of the following measures:

- Reorient or relocate the receiving antenna.
- Increase the separation between the equipment and receiver.
- Connect the equipment to an outlet on a circuit different from that to which the receiver is connected.
- Consult the dealer or an experienced radio/TV technician for help.

This device complies with part 15 of the FCC Rules. Operation is subjected to the following two conditions:

1. This device may not cause harmful interference, and
2. This device must accept any interference received, including interference that may cause undesired operation.

**CAUTION:** To comply with the limits of the Class B digital device, pursuant to Part 15 of the FCC Rules, this device must be installed with computer equipment certified to comply with Class B limits.

All cables used to connect to the computer and peripherals must be shielded and grounded. Operation with non-certified computers or non-shielded cables may result in interference to radio or television reception.

**MODIFICATION:** Any changes or modifications not expressly approved by the grantee of this device could void the user's authority to operate the device.

## Federal Communication Commission (FCC) Radiation Exposure Statement

Power is so low that no RF exposure calculation is needed.



## Notice for Canada

This Class B digital apparatus complies with Canadian ICES-003 and RSS-210.

Cet appareil numérique de la classe B est conforme aux normes canadiennes NMB-003 et CNR-210.

This device complies with Industry Canada licence-exempt RSS standard.

Operation is subjected to the following two conditions:

1. This device may not cause harmful interference, and
2. This device must accept any interference received, including interference that may cause undesired operation.

Cet appareil est conforme avec Industrie Canada RSS standard exempts de licence.

Son fonctionnement est soumis aux deux conditions suivantes :

1. Le matériel ne peut être source D'interférences et
2. Doit accepter toutes les interférences reçues, Y compris celles pouvant provoquer un fonctionnement indésirable.

**CANADIAN CLASS B STATEMENT:** This digital device does not exceed the Class B limits for radio noise emissions from digital apparatus as set out in the interference-causing equipment statement entitled "Digital Apparatus", ICES-003 of the Department of Communications.

Cet appareil numérique respecte les limites de bruits radioélectriques applicables aux appareils numériques de Class B prescrites dans la norme sur le matériel brouilleur. "Appareils Numériques," NMB-003 édictée par le ministre des Communications.

**MODIFICATION:** Any changes or modifications not expressly approved by the grantee of this device could void the user's authority to operate the device.

Toute modification non approuvée explicitement par le fournisseur de licence de l'appareil peut entraîner l'annulation du droit de l'utilisateur à utiliser l'appareil.

## European Compliance

This product conforms to the following:



EMC Directive 2004/108/EC.

RoHS Directive 2011/65/EU.

Mains operated products for the European market comply with Low Voltage Directive 2006/95/EC and Commission Regulation(s) Implementing Directive (2009/125/EC).

Communication/RF wireless products for the European market comply with R&TTE Directive 1999/5/EC.

**CAUTION:** To comply with the Europe CE requirement, this device must be installed with CE certified computer equipment which meet with Class B limits.

All cables used to connect this device must be shielded, grounded and no longer than 3m in length. Operation with non-certified computers or incorrect cables may result in interference to other devices or undesired effects to the product.

**MODIFICATION:** Any changes or modifications not expressly approved by Creative Technology Limited or one of its affiliated companies could void the user's warranty and guarantee rights.

## European Compliance

Ce produit est conforme aux normes suivantes :

Directive 2004/108/CE sur les émissions électromagnétiques.

Directive RoHS 2011/65/UE.

Les produits secteur pour le marché européen sont conformes à la Directive sur la faible tension 2006/95/CE et à la réglementation de la Commission exécutant la Directive 2009/125/CE.

Les produits de communication/sans fil RF destinés au marché européen sont conformes à la directive R&TTE 1999/5/CE.

**ATTENTION :** pour respecter les critères CE d'Europe, cet appareil doit être installé avec du matériel informatique certifié CE respectant les limites de la classe B. Tous les câbles utilisés pour connecter cet appareil doivent être blindés, reliés à la terre et ne pas faire plus de 3 m de long. L'utilisation d'ordinateurs non certifiés ou de câbles inappropriés peut entraîner des interférences avec d'autres appareils ou des effets indésirables sur le produit.

**MODIFICATION :** toute modification non approuvée explicitement par Creative Technology Limited ou l'une de ses sociétés affiliées peut entraîner l'annulation de la garantie et des droits de garantie de l'utilisateur.

## Conformità alle normative europee

Questo prodotto è conforme alla seguente normativa:

Direttiva EMC 2004/108/CE.

Direttiva RoHS 2011/65/UE.

I prodotti che funzionano con corrente di rete per il mercato europeo sono conformi alla direttiva bassa tensione 2006/95/CE e alla direttiva di implementazione nelle normative europee 2009/125/CE.

I prodotti di comunicazione/wireless RF per il mercato europeo sono conformi alla Direttiva R&TTE 1999/5/CE.

**ATTENZIONE:** ai fini della conformità con i requisiti del marchio CE europeo, il dispositivo deve essere installato in un computer certificato CE conforme ai limiti di Classe B. Tutti i cavi usati per collegare il dispositivo devono essere schermati, dotati di idonea messa a terra e avere una lunghezza massima di 3 metri. L'uso del dispositivo con computer non certificati o cavi non idonei può provocare interferenze ad altri dispositivi nonché danneggiare il prodotto stesso.

**MODIFICHE:** eventuali modifiche o alterazioni non espressamente approvate da Creative Technology Limited o dalle sue società controllate possono rendere nulli la garanzia e il diritto dell'utente a utilizzare il prodotto.

## Einhaltung der europäischen Bestimmungen

Dieses Produkt erfüllt die folgenden Bestimmungen:

EMC-Richtlinie 2004/108/EG.

RoHS-richtlinie 2011/65/EU.

Netzbetriebene Produkte für den europäischen Markt erfüllen die Niederspannungsverordnung 2006/95/EG und der Commission Regulation(s) Implementing-Verordnung 2009/125/EG.

Drahtlose Kommunikationsgeräte/Funksender und -empfänger für den europäischen Markt erfüllen die R&TTE-Richtlinie 1999/5/EG.

**ACHTUNG:** Um die Anforderungen der europäischen CE-Norm zu erfüllen, muss dieses Produkt an einem CE-geprüften Computer der Klasse B angeschlossen werden. Alle Verbindungskabel zu diesem Gerät müssen abgeschirmt und geerdet sein und dürfen nicht länger als 3 m sein. Der Betrieb mit nicht zertifizierten Computern oder nicht ordnungsgemäßen Kabeln kann zu Störungen anderer Geräte oder unerwünschten Auswirkungen auf das Produkt führen.

**MODIFIZIERUNG:** Jegliche Änderung oder Modifizierung des Produkts, die nicht ausdrücklich von Creative Technology Limited oder einer der zugehörigen Firmen genehmigt worden ist, kann für den Benutzer zum Erlöschen der Garantie und der Gewährleistungsrechte führen.

## Homologación para Europa

Este producto cumple:

la Directiva de compatibilidad electromagnética 2004/108/CE.

Directiva RoHS 2011/65/UE.

Los productos funcionando con corriente eléctrica cumplen con la Directiva 2006/95/CE de baja tensión y con la implementación de los requisitos de la Comisión para la directiva 2009/125/CE.

Los productos inalámbricos de comunicación o frecuencias de radio para el mercado europeo cumplen la Directiva 1999/5/CE de equipos de radio y terminales de telecomunicaciones.

**ATENCIÓN:** para cumplir con los requisitos de Homologación para Europa, este dispositivo debe instalarse con un equipo informático con certificación CE que cumpla los límites de la Clase B. Todos los cables utilizados para conectar este dispositivo deben estar protegidos, conectados a tierra y no tener más de 3 m de longitud. El funcionamiento del dispositivo con equipos no certificados o cables incorrectos podría provocar interferencias a otros dispositivos o efectos no deseados al producto.

**MODIFICACIÓN:** los cambios o modificaciones no aprobados expresamente por Creative Technology Limited o una de sus empresas afiliadas podrían invalidar la garantía del usuario y los derechos de la garantía.

## Europese naleving

Dit product voldoet aan de volgende voorschriften:

EMC-richtlijn 2004/108/EG.

RoHS-richtlijn 2011/65/EU.

Electrische producten voor de Europese markt voldoen aan de Laagspanningsrichtlijn 2006/95/EG en EC and Verordening(en) voor uitvoering van Richtlijn 2009/125/EG.

Communicatie- of draadloze RF-producten voor de Europese markt voldoen aan de richtlijn R&TTE 1999/5/EG.

**LET OP:** Om te voldoen aan de Europese CE-norm, moet dit apparaat zijn geïnstalleerd in computerapparatuur die CE-gecertificeerd is voor de Klasse B-limieten. Alle kabels die worden gebruikt om dit apparaat aan te sluiten, moeten zijn afgeschermd en geaard, en mogen niet langer dan 3 meter zijn. Gebruik met niet-gecertificeerde computers of incorrecte kabels kan leiden tot interferentie van andere apparaten of ongewenste effecten op het product.

**AANPASSING:** Alle wijzigingen of modificaties die niet uitdrukkelijk zijn goedgekeurd door Creative Technology Limited of een van de gelieerde maatschappijen, kunnen ertoe leiden dat de rechten van de gebruiker met betrekking tot garantie en vrijwaring vervallen.

## Conformidade Europeia

Este produto está em conformidade com a seguinte regulamentação:

Directiva EMC 2004/108/EC.

Directiva RoHS 2011/65/UE.

Os produtos com ligação à rede destinados ao mercado europeu estão em conformidade com a directiva de baixa voltagem 2006/95/CE. Directiva de Implementação do(s) Regulamento(s) da Comissão 2009/125/CE.

Os produtos de comunicação/radiofrequência sem fios destinados ao mercado europeu estão em conformidade com a directiva R&TTE 1999/5/CE.

**ATENÇÃO:** De modo a cumprir com os requisitos da marca CE Europeia, este dispositivo deve ser instalado com equipamento informático com certificação CE que cumpra com os limites de Classe B limits. Todos os cabos usados para ligar este dispositivo devem ser blindados, ligados à terra e não devem exceder os 3m de comprimento. O funcionamento com computadores não certificados ou cabos

incorrectos pode resultar em interferências em outros dispositivos ou provocar efeitos indesejados no produto.

**MODIFICAÇÃO:** Quaisquer alterações ou modificações que não sejam expressamente aprovadas pela Creative Technology Limited ou por uma das suas afiliadas, pode anular a garantia do utilizador e os direitos inerentes à mesma.

## Europeisk efterlevnad

Denna produkt uppfyller följande:

EMC-direktivet 2004/108/EC.

RoHS Direktivet 2011/65/EU.

Produkter för den europeiska marknaden som drivs via elnätet uppfyller Lågspänningsdirektivet 2006/95/EC och Kommissionens regleringsimplementeringsdirektiv 2009/125/EG.

Trådlösa kommunikations/RF-produkter för den europeiska marknaden uppfyller R&TTE-direktivet 1999/5/EC.

**WARNING:** För att uppfylla CE-kraven i Europa måste denna produkt installeras med CE-certifierad datorutrustning som uppfyller gränsvärdena för klass B. Alla kablar som används för anslutning av denna produkt måste vara avskärmade, jordade och får inte vara längre än 3 m. Användning med icke certifierade datorer eller felaktiga kablar kan leda till interferens på annan utrustning eller oönskade effekter på produkten.

**MODIFIERING:** Alla förändringar och modifieringar som inte är uttryckligen tillåtna av Creative Technology limited eller något av dess filialföretag kan göra användarens garanti och garantirättigheter ogiltiga.

## Europeisk samsvar

Dette produktet er i samsvar med følgende:

EMC-direktivet 2004/108/EC.

RoHS-Direktivet 2011/65/EU.

Elektriske produkter til det europeiske markedet er i samsvar med Lavspenningsdirektivet 2006/95/EC og Økodesigndirektivet 2009/125/EC.

Kommunikasjon/RF trådløse produkter til det europeiske markedet er i samsvar med R&TTE-direktivet 1999/5/EC.

**ADVARSEL:** For å overholde det europeiske CE-kravet må denne enheten installeres med CE-sertifisert datautstyr som tilfredsstiller klasse B-grensene. Alle kabler som kobles til enheten må være skjermet, jordet og ikke lenger enn 3 m i lengde. Bruk av ikke-sertifiserte datamaskiner eller feil kabler kan føre til forstyrrelse av andre enheter eller uønsket effekt på produktet.

**MODIFIKASJON:** Eventuelle endringer eller modifikasjoner som ikke uttrykkelig er godkjent av Creative Technology Limited eller et av dets tilknyttede selskaper, kan ugyldiggjøre garantien eller garantirettighetene.

## Overholdelse af Europæiske regler og standarder

Dette produkt overholder følgende:

EMC-direktivet 2004/108/EC.

RoHS-Direktivet 2011/65/EU.

Produkter til det Europæiske marked, skal overholde Lavspændingsdirektivet 2006/95/EC og Kommissionens forordninger for implementering af direktivet 2009/125/EF.

Kommunikations- / RF-trådløse produkter til det Europæiske overholder R&TTE-direktivet 1999/5/EC.

**ADVARSEL:** For at overholde Europe CE-kravet, skal denne enheden installeres med CE-certificeret computerudstyr, der opfylder klasse B-grænserne. Alle kabler der anvendes til at tilslutte enheden skal være skærmede, jordforbundne og ikke længere end 3 m lange. Drift med ikke-certificerede computere og ukorrekte kabler kan medføre interferens for andre enheder eller uønskede effekter på produktet.

**MODIFIKATION:** Enhver ændring eller modifikation, der ikke er udtrykkeligt godkendt af Creative Technology Limited eller et associerede selskab, vil gøre brugerens garanti og garanterede rettigheder ugyldig.

## Eurooppalainen yhdenmukaisuus

Tämä tuote täyttää seuraavat tuotemääritykset:

EMC-direktiivin 2004/108/EC.

RoHS-direktiivin 2011/65/EU.

Euroopan markkinoiden verkkovirtaa käyttävät tuotteet ovat matalajännitedirektiivin 2006/95/EY mukaisia. Euroopan parlamentin ja neuvoston ohjaava direktiivi 2009/125/EY.

Euroopan markkinoiden tietoliikenne- ja langattomat radiotaajuustuotteet noudattavat R&TTE-direktiiviä 1999/5/EY.

**VAROITUS:** Jotta tämä laite noudattaisi Euroopan CE-vaatimuksia, tämä laite on asennettava CE-sertifioituun tietokoneeseen, joka noudattaa luokan B rajoituksia. Kaikki tämän laitteen liittämiseen käytetyt kaapelit tulee suojata ja maadoittaa eivätkä ne saa olla 3 m pidempiä. Luokan rajoituksia noudattamattoman tietokoneen tai vääränlaisten kaapeleiden käyttäminen voi aiheuttaa häiriöitä muihin laitteisiin tai haitata itse laitteen toimintaa.

**MUOKKAUKSET:** Muutokset tai muokkaukset, joita Creative Technology Limited tai sen tytäryhtiöt eivät nimenomaisesti ole hyväksyneet, voivat mitätöidä tuotteelle annettua takuun.

## Evropská shoda

Tento výrobek splňuje následující směrnice:

Směrnice EMC 2004/108/EC.

Směrnice RoHS 2011/65/EU.

Výrobky napájené z elektrické zásuvky pro evropský trh splňují směrnici o nízkém napětí 2006/95/EC a směrnici komise 2009/125/EC o zavádění předpisů.

Komunikační / vysokofrekvenční bezdrátové výrobky pro evropský trh splňují směrnici R&TTE 1999/5/EC.

**UPOZORNĚNÍ:** Aby toto zařízení splňovalo evropský požadavek CE, musí být nainstalováno s počítačovým vybavením s certifikátem CE, které splňuje limity pro zařízení třídy B. Veškeré kabely používané pro připojení tohoto zařízení musí být stíněné, uzemněné a nesmí být delší než 3 metry. Při používání s necertifikovanými počítači nebo nesprávnými kabely může dojít k rušení jiných zařízení nebo k nežádoucím vlivům na produkt.

**ÚPRAVY:** Jakékoli změny nebo úpravy, které nebyly vysloveně schváleny společností Creative Technology Limited nebo některou z jejích dceřiných společností, mohou způsobit propadnutí záruky uživatele a záručních práv.

## Zgodność z przepisami europejskimi

Urządzenie jest zgodne z

dyrektywą EMC 2004/108/EC.

Dyrektywa RoHS 2011/65/UE.

Urządzenia zasilane z sieci elektrycznej przeznaczone na rynek europejski muszą być zgodne z dyrektywą dotyczącą urządzeń niskonapięciowych 2006/95/EC oraz z dyrektywą wdrażającą komisji regulacyjnej 2009/125/WE.

Urządzenia komunikacyjne / bezprzewodowe wykorzystujące transmisję radiową przeznaczone na rynek europejski spełniają warunki dyrektywy RTTE 1999/5/EC.

**UWAGA:** Aby uzyskać zgodność z wymogami europejskiej normy CE urządzenie musi być zainstalowane wraz ze sprzętem komputerowym mającym certyfikat CE z ograniczeniami klasy B. Wszystkie przewody używane do podłączania niniejszego urządzenia muszą być ekranowane, uziemione i nie dłuższe niż 3 metry. Użytkowanie z komputerami nie posiadającymi certyfikatów lub wykorzystanie niewłaściwych przewodów może powodować zakłócenia pracy innych urządzeń lub opisywanego urządzenia.

**MODYFIKACJE:** Dokonanie jakichkolwiek zmian lub modyfikacji, na które firma Creative Technology Limited lub spółki z nią stowarzyszone nie udzielają wyraźnej zgody, może doprowadzić do unieważnienia praw gwarancji i rękojmi użytkownika.

## Соответствие европейским нормам

Данное изделие соответствует следующим стандартам:

EMC Директива 2004/108/ЕС.

RoHS директива 2011/65/EU.

Продукция с питанием от сети, поставляемая на европейский рынок, соответствует Директиве по низковольтному оборудованию 2006/95/ЕС и Имплементирующей директиве постановления (-й) комиссии 2009/125/ЕС.

Κομμυνικακιοννιο/ραδιο- βεσπρωοννιο οβοροοννιο, ποστωλαιομιο να ευρωποιικий ρυνοκ, σοοτωποστωει Διρεκιτωι πο οκονοχιοννιο ραδιο- και τηλεκομμυνικακιοννιο οβοροοννιο 1999/5/ΕΚ.

**ВНИМАНИЕ!** Для обеспечения соответствия европейским требованиям CE, это устройство должно устанавливаться с компьютерным оборудованием, сертифицированным по стандарту CE и удовлетворяющим нормам класса B. Все кабели, используемые для подключения данного устройства, должны быть экранированы, заземлены и иметь длину не более 3 м. Работа с несертифицированными компьютерами или неподходящими кабелями может привести к возникновению помех другим устройствам или негативному влиянию на работу самого изделия.

**ИЗМЕНЕНИЯ КОНСТРУКЦИИ** Любые изменения конструкции, на которые не было получено прямое разрешение компании Creative Technology Limited или ее дочерней компании, может привести к аннулиции гарантии и связанных с нею прав.

## Európai megfeleléség

Ez a termék megfelel a következőknek:

2004/108/EGK sz., az elektromágneses összeférhetőségre. 2011/65/EU, RoHS.

Az Európa területére szánt hálózati termékek megfelelnek az alacsony feszültségre vonatkozó 2006/95/EC irányelvnek.

Az irányelvet 2009/125/EK végrehajtó bizottsági rendeletek.

Az Európa területére szánt, távközlési, illetve rádiófrekvenciás vezeték nélküli termékek megfelelnek a rádiós távközlő végberendezésekre vonatkozó 1999/5/EK irányelvnek.

**FIGYELEM!** Az európai CE követelmények teljesítéséhez ezt a készüléket a B kategóriájú értékeknek megfelelő, CE minősítésű számítógéppel együtt kell telepíteni. A készülék csatlakoztatására használt valamennyi kábelnek árnyékoltnak és földeltnek kell lennie, továbbá hosszúsága nem haladhatja meg a 3 métert. A nem hitelesített számítógépekkel vagy helytelen kábelekkel való használat más készülékek zavarását vagy a termék nem kívánatos befolyásolását okozhatja.

**MÓDOSÍTÁS:** Minden módosítás vagy változtatás, amit kifejezetten nem hagyott jóvá a Creative Technology Limited vagy valamelyik leányvállalata, érvénytelenítheti a készülék garanciáját és felhasználó garanciális jogait.

## Ευρωπαϊκή συμμόρφωση

Το παρόν προϊόν συμμορφώνεται με τα παρακάτω:

Οδηγία ΗΜΣ 2004/108/ΕΚ.

Οδηγία RoHS 2011/65/ΕΕ.

Τα προϊόντα που λειτουργούν με ρεύμα για την ευρωπαϊκή αγορά συμμορφώνονται με την Οδηγία περί χαμηλής τάσης 2006/95/ΕΚ και τους κανονισμούς της επιτροπής που υλοποιούν την οδηγία 2009/125/ΕΚ.

Τα ασύρματα προϊόντα επικοινωνιών / RF για την ευρωπαϊκή αγορά συμμορφώνονται με την οδηγία R&TTE 1999/5/ΕΚ.



**ΠΡΟΣΟΧΗ:** Για τη συμμόρφωση με τις απαιτήσεις του ευρωπαϊκού CE, αυτή η συσκευή θα πρέπει να εγκατασταθεί σε εξοπλισμό υπολογιστή με πιστοποίηση CE ο οποίος πληροί τα όρια της κατηγορίας B. Όλα τα καλώδια που χρησιμοποιούνται για τη σύνδεση της συσκευής θα πρέπει να είναι θωρακισμένα, γειωμένα και να μην υπερβαίνουν σε μήκος τα 3μ. Η λειτουργία με μη πιστοποιημένους υπολογιστές ή λάθος καλώδια μπορεί να οδηγήσει σε παρεμβολές με άλλες συσκευές ή ανεπιθύμητες επιδράσεις στο προϊόν.

**ΤΡΟΠΟΠΟΙΗΣΗ:** Οι όποιες αλλαγές ή τροποποιήσεις που δεν έχουν εγκριθεί ρητά από την Creative Technology Limited ή κάποια από τις θυγατρικές της ενδέχεται να ακυρώσουν την εγγύηση του χρήστη και τα δικαιώματα που απορρέουν από αυτήν

## Europos Sąjungos atitiktis

Šis gaminys atitinka šiuos reikalavimus:

„Elektromagnetinės atitikties“ („EMC“) direktyva 2004/108/EC.

RoHS direktyva 2011/65/ES.

Produktai, kurie veikia maitinami iš elektros tinklo, skirti Europos rinkai, atitinka Žemos įtampos direktyvą 2006/95/EB.

Komisijos reglamentas(-ai) dėl Direktyvos 2009/125/EB įgyvendinimo.

Europos Sąjungos rinkai skirti ryšių / radijo dažnių bevieliai gaminiai atitinka 1999/5/EB direktyvą „Dėl radijo ryšio įrenginių ir telekomunikacijų galinių įrenginių bei abipusio jų atitikties pripažinimo“.

**ATSARGIAI:** Tam, kad šis prietaisas atitiktų Europos Sąjungos „CE“ reikalavimus, jis turi būti įdiegtas į „CE“ sertifikuotą kompiuterinę įrangą, atitinkančią „B“ klasės ribas. Visi su šiuo prietaisu naudojami laidai turi būti ekranuoti, izeminti ir neviršyti 3 m ilgio. Nesertifikuotų kompiuterių ar netinkamų laidų naudojimas gali tapti trikdžių kitiems prietaisams arba nepageidaujamų šio gaminio veikimo pasekmių priežastimi.

**MODIFIKAVIMAS:** Bet kokie pakeitimai ar modifikavimai neturint aiškiai patvirtinto „Creative Technology Limited“ ar vienos iš su ja susijusių bendrovių leidimo gali panaikinti vartotojo garantiją ir garantijos teises.

## Europeisk överensstämmelse

Denna produkt uppfyller följande:

EMC-direktivet 2004/108/EC.

RoHS-direktivet 2011/65/EU.

Produkter som ansluts till elnätet och som är avsedda för den europeiska marknaden uppfyller lågspänningsdirektivet 2006/95/EC.

Nariadenia komisie, ktorými sa vykonáva smernica 2009/125/ES.

Trådlösa kommunikationsprodukter/RF-produkter för den europeiska marknaden uppfyller R&TTE-direktivet 1999/5/EC.

**WARNING!** För att överensstämma med de europeiska CE-kraven måste denna enhet installeras tillsammans med CE-godkänd utrustning som uppfyller Klass B-gränserna. Alla kablar som används

vid anslutning av denna enhet måste vara skärmade och jordade samt inte vara längre än 3m. Användning tillsammans med icke-godkända datorer eller felaktiga kablar kan orsaka störningar i andra enheter eller oönskade effekter i denna produkt.

**ÄNDRING:** Varje ändring eller modifiering som inte uttryckligen godkänts av Creative Technology Limited eller ett av dess dotterbolag kan göra att användarens garanti eller garantirättigheter upphör att gälla.

## Avrupa Uyumu

Bu ürün aşağıdakilere uygundur:

2004/108/EC EMC (Elektromanyetik Uyumluluk) Yönetmeliği.

2011/65/EC RoHS (Tehlikeli Maddelerin Kısıtlanması) Yönetmeliği

Avrupa piyasasına yönelik, elektrik şebekesi tarafından çalıştırılan ürünler 2009/125/EC Düşük Voltaj Yönetmeliği ve Komisyon Düzenlemelerini Uygulama Yönetmeliğine (2005/32/EC) uygundur.

Avrupa piyasasına yönelik İletişim / RF kablosuz ürünleri R ve TTE Yönetmeliği 1999/5/EC ile uyumludur.

**DİKKAT:** Avrupa CE gereksinimleriyle uyumlu olması için bu cihazın, B Sınıfı sınırlarına uygun olan CE sertifikalı bilgisayar donanımları ile birlikte kurulması gerekir. Bu cihazı bağlamak için kullanılan tüm kabloların koruyuculu ve topraklanmış olması ve 3 metreden uzun olmaması gerekir. Sertifikalı olmayan bilgisayarlarla veya yanlış kablolarla birlikte kullanılması, diğer cihazların düzgün çalışmamasına veya üründe istenmeyen etkiler görülmesine neden olabilir.

**DEĞİŞİKLİKLER:** Creative Technology Limited veya bağlı şirketlerinden biri tarafından açıkça onaylanmamış tüm değişiklikler kullanıcının garanti ve teminat haklarını geçersiz kılabilir.

## Ukraine RoHS Statement

Обладнання відповідає вимогам Технічного регламенту щодо обмеження використання деяких небезпечних речовин в електричному та електронному обладнанні, затвердженого постановою Кабінету Міністрів України від 3 грудня 2008 № 1057

## Notice for Singapore

Complies with  
IDA Standard  
DB00148

## Notice for Korea

**B급 기기**

(가정용 방송통신기자재)

이 기기는 가정용 (B급) 전자파적합 기기로서 주로 가정에서 사용하는 것을 목적으로 하며, 모든 지역에서 사용할 수 있습니다.

## Notice for Japan

### Recycling Rechargeable Battery



**Li-ion**

Lithium rechargeable battery is a resource that can be recycled.

- For recycling of embedded lithium rechargeable batteries inside Creative products, please do not attempt to remove the battery from the device. For recycling information and instruction, please go to Creative Media KK customer support at <http://jp.creative.com/support/contact/>
- For recycling of replaceable (removable\_ lithium rechargeable batteries:



**注意事項**

- It is recommended to remove the rechargeable batteries when they are fully discharged.
- Precaution needs to be taken on metal parts of the battery by covering them with isolation materials such as scotch tape.
- Refer to the homepage of JBRC for information on recycling and recovery of rechargeable batteries and supporting shops. (<http://www.jbrc.com/>).

## Vietnam RoHS Statement

This product is in compliance with Circular 30/2011/TTBCT of the Ministry of Trade of the Socialist Republic of Vietnam ("Circular"), it does not contain the following substances in concentration greater than the Maximum Limit value as specified in the Circular.

Substance	Maximum Limit (ppm) <sup>1, 2</sup>
• lead	1000
• mercury	1000
• cadmium	100
• hexavalent chromium	1000
• polybrominated biphenyls (PBB)	1000
• polybrominated diphenyl ethers (PBDE)	1000

<sup>1</sup> Maximum Limit does not apply to applications exempted from the Circular.

<sup>2</sup> Maximum Limit refers to concentration by weight in homogeneous materials.

# License and Copyright

Information in this document is subject to change without notice and does not represent a commitment on the part of Creative Technology Ltd. No part of this manual may be reproduced or transmitted in any form or by any means, electronic or mechanical, including photocopying and recording, for any purpose without the written permission of Creative Technology Ltd.

© 2013 Creative Technology Ltd. All rights reserved. Creative, the Creative logo, CrystalVoice, Sound Blaster, the Sound Blaster logo, EVO, Creative ALchemy, SBX Pro Studio and the SBX logo are trademarks or registered trademarks of Creative Technology Ltd. in the United States and/or other countries. The *Bluetooth*<sup>®</sup> word mark and logos are registered trademarks owned by Bluetooth SIG, Inc. and any use of such marks by Creative Technology Ltd is under license. apt-X is a registered trademark of APT Licensing Ltd. Android is a trademark of Google Inc. Windows and Windows Vista are registered trademarks of Microsoft Corporation. iPad, iPhone, iPod, and Mac OS are registered trademarks of Apple Inc. All other trademarks are properties of their respective owners. All specifications are subject to change without prior notice. Use of this product is subject to a limited hardware warranty. Actual contents may differ slightly from those pictured. The software available for this product may not be used separately from the hardware. Before using the software, you must agree to be bound by the terms and conditions of the end user license agreement.

Version 1.0

May 2013