

CREATIVE

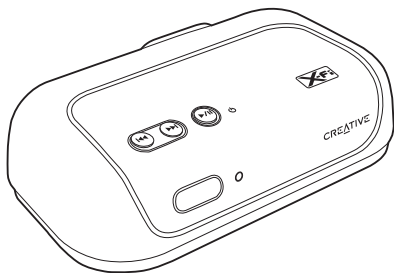

Wireless Receiver

User's Guide

Congratulations!

Your Creative Wireless Receiver complements Creative transmitters like Cambridge Soundworks MovieWorks™ HD and Creative Sound Blaster® X-Fi™ Notebook®. Together, your receiver and transmitter enable you to enjoy the X-Fi difference, wherever you are in your home, wirelessly. Read on to learn how to get started with your new Creative Wireless Receiver!

Contents

| | |
|---|----|
| About Your Receiver | 2 |
| About Your Remote Control | 3 |
| Setting Up Your Receiver | 4 |
| Setting Up Two or More Receivers | 10 |
| About Broadcasting and Zone Control | 11 |
| Manual Pairing | 12 |
| Using Your Receiver | 16 |
| Using Your Wireless Features | 18 |
| Troubleshooting Wireless Features | 21 |
| FAQs | 24 |
| General Specifications | 26 |
| Safety Information | 27 |
| Regulatory Information | 29 |

NOTE The term “receiver” used throughout this User’s Guide refers to the Creative Wireless Receiver. “Transmitter” refers to any of the Creative transmitters mentioned above.

About Your Receiver

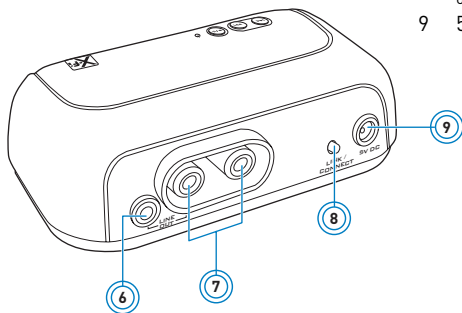
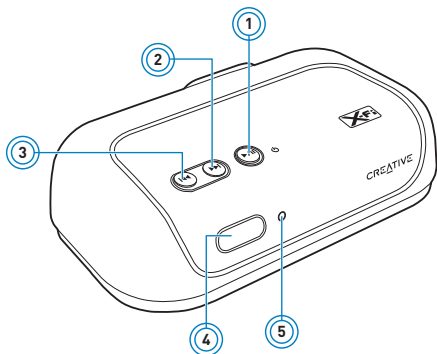

- 1 **Power/Standby and Play/Pause button**
Press to turn on.
Press and hold to enable Standby mode.
- 2 **Next/Fast forward button**
Press and hold to Fast forward.
- 3 **Previous/Rewind button**
Press and hold to Rewind.
- 4 **Infrared receiver**
- 5 **Power LED**
See "Understanding the Power LED" on page 17.
- 6 **Line Out jack**
- 7 **RCA Audio Line Out jacks**
- 8 **Link LED/Connect button**
See "Understanding the Link LED" on page 17.
- 9 **5V DC In jack**

About Your Remote Control

Your remote control has an operating distance of up to three meters (approximately 9.8 feet).

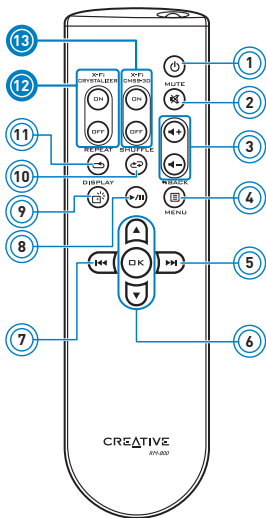

- 1 Power/Standby
- 2 Mute on/off
- 3 Volume
- 4 iPod® Back/Menu*
- 5 Next/Fast forward
Press and hold to Fast forward.
- 6 Menu Navigation buttons
Press OK to execute the selected menu option.
- 7 Previous/Rewind
Press and hold to Rewind.
- 8 Play/Pause
- 9 iPod Display*
- 10 Shuffle
- 11 Repeat
- 12 X-Fi Crystalizer® on/off^
- 13 X-Fi CMSS® -3D on/off^

* For use with transmitters that support iPod players.

^ Pressing the X-Fi buttons on the receiver's remote control effectively controls the X-Fi enhancements of the transmitter, and this in turn affects the output of all paired receivers.

Setting Up Your Receiver

Step 1: Position your receiver

Place your receiver near a power outlet, and up to 30 meters (approximately 98 feet) away from your transmitter. You may place the units in different rooms but avoid placing them near large metal surfaces and objects, or objects emitting radio frequencies, for example, a radio or cordless phone.

NOTE Signal quality between the transmitter and receiver may be affected by any object or structure (for example, multiple walls) that is between the units. Experiment with different positions if necessary.

Step 2: Insert batteries into your remote control

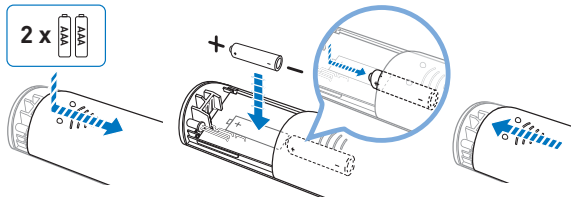

IMPORTANT The cover of your remote control can only be opened halfway. Do not try to detach the cover when inserting the batteries.

NOTE To remove the batteries when they are depleted, use the same method as shown above to open the cover.

Step 3: Connect your receiver

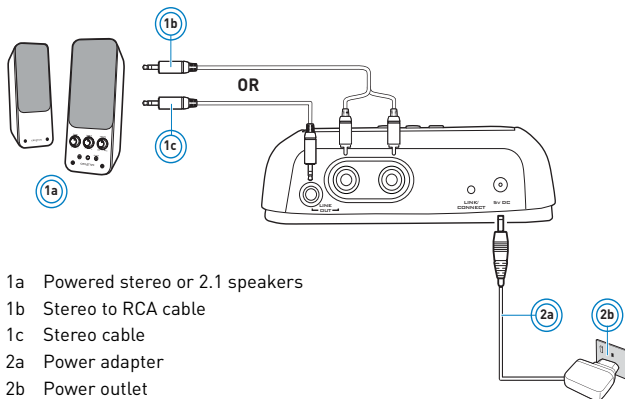

Step 4: Turn on your transmitter

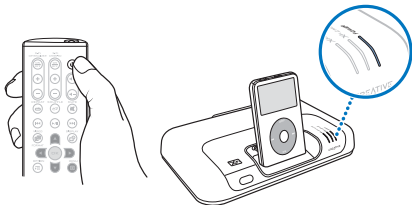

MovieWorks HD

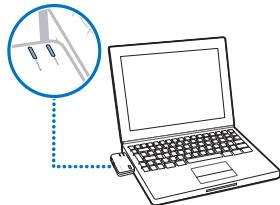

Sound Blaster
X-Fi Notebook

- NOTE**
- For Sound Blaster X-Fi Notebook, the device's wireless features are disabled by default. You must enable it in Entertainment Mode and ensure that the device's Connect LED lights up green. See "Enabling Wireless Music Control" on the next page.

Enabling Wireless Music Control

The following steps are applicable only if you are using Sound Blaster X-Fi Notebook as your transmitter.

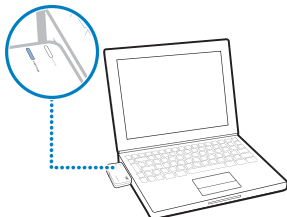

Sound Blaster X-Fi Notebook

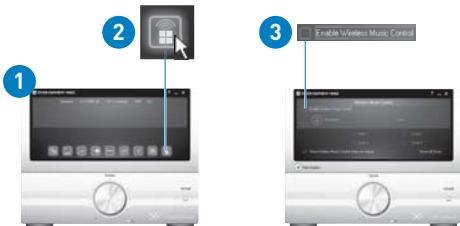

- 1 Launch Entertainment Mode. To do this, click **Start -> Programs -> Creative -> Sound Blaster X-Fi Notebook -> Creative Console Launcher**.
- 2 Click the Wireless Music Control button.
- 3 Select the **Enable Wireless Music Control** check box.
The device's Connect LED lights up green.

Step 5: Turn on your receiver

Your transmitter and receiver pair (connect wirelessly) automatically when turned on. The Link LED, at the back of the receiver, flashes and then lights up green when pairing is successful.

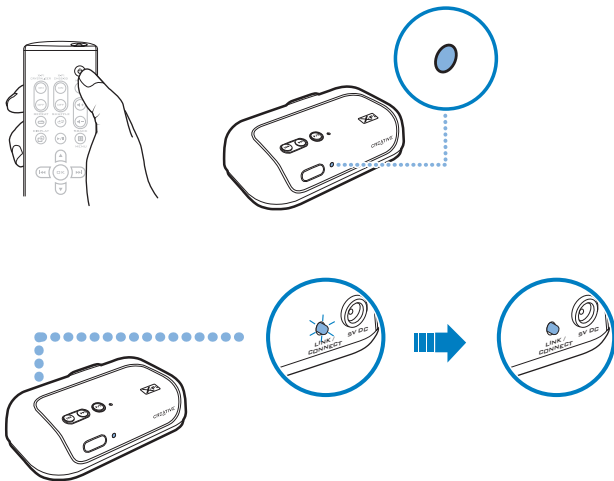

NOTE If your transmitter and receiver do not pair, simply reset them. On one unit at a time, press and hold the Connect button for five seconds. For more troubleshooting information, see “Troubleshooting Wireless Features” on page 21.

Step 6: Play and stream music from transmitter

Play music on your transmitter and broadcast music to your receiver.

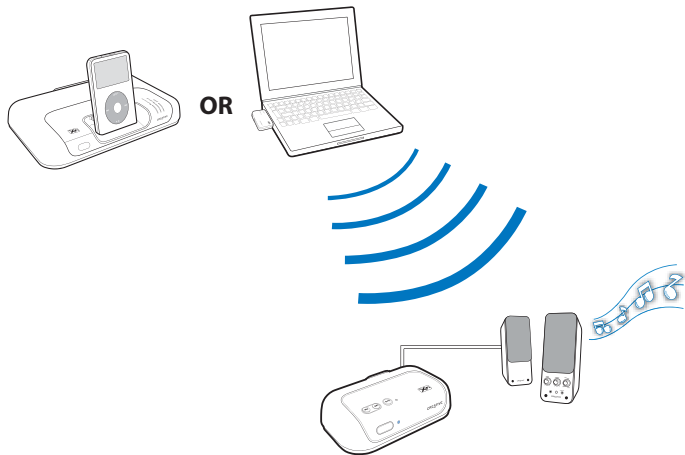

Setting Up Two or More Receivers

Repeat Steps 1 to 2 in “Setting Up Your Receiver” on page 4. In Step 4, turn on all your receivers. Your receivers pair automatically with your transmitter, and you can start playing music on all your receivers.

To deactivate your receiver(s)

Press the Broadcast  button on your transmitter remote control.

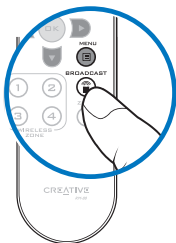

MovieWorks HD

Your receiver is deactivated and stops streaming music. If you have more than one receiver, all of them will be deactivated.

NOTE For Sound Blaster X-Fi Notebook, click the **Enable Wireless Music Control** check box in Entertainment Mode to activate or deactivate your receiver.

About Broadcasting and Zone Control

These wireless features enable you to control your receivers remotely from your transmitter, using the Broadcast and Zone control buttons found on your transmitter remote control or the Entertainment Mode console.

Broadcasting can be used on any number of paired receivers. This feature enables you to activate or deactivate all paired receivers simultaneously.

Zone control is limited to the first four manually paired receivers. This feature enables you to activate or deactivate each paired receiver individually.

To use Broadcasting, pair your transmitter and receiver automatically (see “Setting Up Your Receiver” on page 4 and “Setting Up Two or More Receivers” on page 10) or manually (see “Manual Pairing” on page 12). To use Zone control, you must pair the receivers manually.

For more information on using the broadcasting and zone control features, see “Using Your Wireless Features” on page 18.

Manual Pairing

This section shows you how to pair your transmitter manually with two to four receivers. If you wish to use Zone control, you must pair your units manually.

Only the first four manually paired receivers will be assigned to a wireless zone. Each manually paired receiver will be assigned to the next available zone.

Each receiver or zone is controlled by the corresponding Zone control button on your transmitter remote control.

TIPS You may pair your receiver manually before positioning it.

Step 1: Press the Connect button on your transmitter

With your transmitter and receivers turned on, press and release the Connect button on your transmitter. The transmitter's Link/Connect LED flashes.

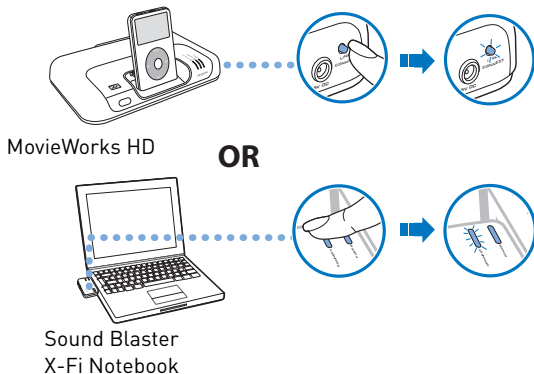

Step 2: Press the Connect button on your first receiver

This must be done within three minutes after pressing the Connect button on the transmitter (Step 1). Once the transmitter and receiver are paired successfully, the Link/Connect LED on both units light up green and remain on. The first receiver to be paired will be assigned to Zone 1.

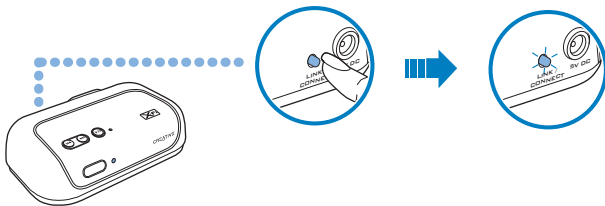

IMPORTANT DO NOT press the Connect button repeatedly on your transmitter or receiver before a pairing process is complete or else you may not be able to perform the correct zone assignment for your receivers.

- NOTE**
- For more information about the Link LED, see “Understanding the Link LED” on page 17.
 - For troubleshooting information, see “Troubleshooting Wireless Features” on page 21.

Step 3: Press the Connect button on your transmitter again

The transmitter's Link/Connect LED flashes. Refer to the diagram in Step 1.

Step 4: Press the Connect button on your second receiver

Refer to the diagram in Step 2. Once the transmitter and receiver are paired successfully, the Link/Connect LED on both units light up green and remain on. Repeat the steps to pair your third and fourth receivers (if applicable) manually.

Step 5: Test your receivers

- 1** Play music from your transmitter.
- 2** Press the Zone number buttons (1 to 4) assigned to the receivers you want to activate or deactivate.

For more information on how to use your Broadcast, Wireless Zone and Zone buttons, see "Using Your Wireless Features" on page 18.

NOTE For Sound Blaster X-Fi Notebook, perform these functions using Entertainment Mode.

Using Your Receiver

Turning on your receiver or enabling Standby mode

Press the Power/Standby button on your remote control to turn on the receiver, or enable Standby mode.

NOTE You can also use the Play/Pause button  on your receiver. See “About Your Receiver” on page 2.

Returning to factory default settings

Return to the factory default settings if you want to

- revert to the original volume setting,
- reset your zone numbering sequence, or
- “unpair” a receiver.

Press and hold the Previous/Rewind and Next/Fast forward buttons on your receiver together for five seconds. The Power LED goes off for two seconds before lighting up again.

NOTE The receiver pairs with your transmitter automatically if both return to factory default settings.

Understanding the Power LED

| LED | Behavior | Status |
|-------|--------------------------|--|
| White | Stable | Turned on and ready for use |
| | Continuous slow flashing | Not detecting any signal or signal is weak |
| Red | Stable | In Standby mode |
| | Quick flashing (twice) | Receiving remote control signals |
| | Continuous slow flashing | Muted |

Understanding the Link LED

| LED | Behavior | Status |
|---------|---|--------------------------------------|
| Green | Stable | Paired (Turned on / In Standby mode) |
| | Flashing | Pairing in progress |
| | Quick flashing (twice) -> Not lit -> Stable | Wireless reset |
| Not lit | - | Connection lost |

Using Your Wireless Features

Use your transmitter remote control, not your receiver remote control, to control the wireless features on your transmitter.

To activate all receivers

To activate or deactivate all your receivers at the same time:

For MovieWorks HD

Press the Broadcast  button.

For Sound Blaster X-Fi Notebook

Click the **Enable Wireless Control** check box in Entertainment Mode.

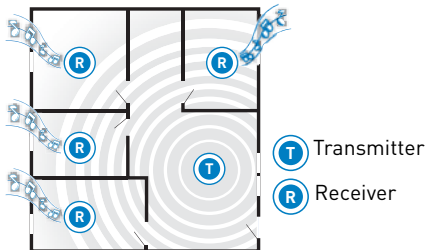

MovieWorks HD



OR



Sound Blaster X-Fi Notebook

To activate selected receivers

For MovieWorks HD

Press the Zone number buttons (1 to 4) assigned to the receivers you want to activate or deactivate.

For Sound Blaster X-Fi Notebook

Click the Zone button, and then click the Zone number buttons (1 to 4) assigned to the receivers you want to activate or deactivate.

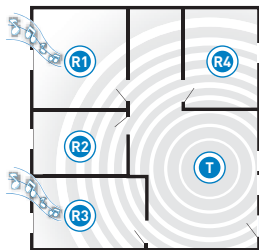

- Transmitter
- Receiver



MovieWorks HD

OR

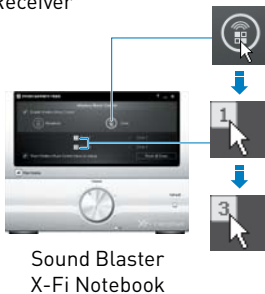

Sound Blaster
X-Fi Notebook

To activate saved receivers only

Below is an example of how you can save your favorite combination of receivers (for example, receivers 1 and 3) and activate them later using the Zone button.

For MovieWorks HD

- 1 Ensure that only receivers 1 and 3 are activated (turned on). If you have four manually paired receivers that are all activated, deactivate receivers 2 and 4 by pressing the Zone 2 and 4 buttons.
- 2 Press the Zone  button. Your transmitter will save this combination (zones 1 and 3). Receivers 1 and 3 will then be on Standby mode.

NOTE Your transmitter can only save and reactivate one combination of receivers. It remembers the last combination of activated receivers just before the Zone button is pressed.

- 3 Press the Zone  button. Only receivers 1 and 3 will be activated.
- 4 To deactivate receivers 1 and 3, press the Zone button again.

For Sound Blaster X-Fi Notebook

- 1 Ensure that only receivers 1 and 3 are activated (turned on). Zone buttons 1 and 3 should be highlighted in Entertainment Mode. If you have four manually paired receivers that are all activated, deactivate receivers 2 and 4 by clicking the Zone 2 and 4 buttons.
- 2 Click the **Enable Wireless Music Control** check box to deselect it. Receivers 1 and 3 will then be on Standby mode.
- 3 Click the **Enable Wireless Music Control** check box again to select it. Only receivers 1 and 3 will be activated.

Troubleshooting Wireless Features

It is unlikely you will experience any problem if the receiver is used in normal circumstances. Here are some tips if you do encounter these problems.

There is no sound from my receiver.

Try the following:

- Make sure your transmitter and receiver are connected to the power outlets and turned on.
- Make sure the Link/Connect LEDs are green, and your units are paired. See “Understanding the Link LED” on page 17.
- Reset the wireless connection. Press and hold the receiver’s Connect button for five seconds.

See also “Why can’t I hear any sound from my speakers?” on page 24.

The Link LEDs do not light up.

This indicates that the signal from the transmitter is weak or the receiver has lost its connection with the transmitter.

Try the following:

- Move your transmitter and receiver closer to each other.
- Reposition your transmitter or receiver so that there are fewer objects (for example, multiple walls or large metal structures) between them.
- Make sure your transmitter and receiver are not placed on metal surfaces.
- Reset the wireless connection. Press and hold the receiver’s Connect button for five seconds.

- Disconnect the transmitter and receiver from the power source. Then reconnect them again and reset the wireless connection.

The wireless connection does not seem to work. I cannot hear music playing from my receiver.

Try the following:

- First turn on other wireless products in the vicinity. For example, turn on your wireless router first, before turning on your transmitter.

My receiver seems to be picking up extra noise, or there are intermittent pauses.

The placement of your receiver as well as the signals from other wireless routers or Bluetooth equipment may affect the quality of the transmission.

Try the following:

- Move your transmitter and receiver closer to each other. For best performance, place your transmitter and receiver on the same floor.
- Place your transmitter or receiver away from other devices that transmit wireless signals. The receiver may also pick up noise from nearby power supply equipment.
- Reposition your transmitter or receiver so that there are fewer objects (for example, multiple walls or large metal structures) between them.

I have two Creative transmitters. My receiver is receiving the incorrect transmission.

Your receiver may be alternating transmissions between the transmitters.

Try the following:

- Manually pair your receivers. See “Manual Pairing” on page 12.

(For Sound Blaster X-Fi Notebook only)**My receiver seems to be picking up extra noise or there are intermittent pauses.**

If the tips listed on page 22 above do not work, try the following:

- Set your wireless LAN router's channel to Auto, 1 or 11. To do this, refer to your router's user documentation.
- Refrain from doing large file transfers via the wireless internet or Bluetooth connection while you are streaming music. Alternatively, stop streaming music during intensive file transfers.

When I switch my recording source from Mic In to Line In in Entertainment Mode, the wireless connection is lost.

When the recording source is changed to Mic In, wireless music control is automatically disabled so that input from the microphone (for example, a private internet voice conversation) will not be unintentionally streamed to all paired receivers. After changing the recording source back to Line In, you must enable the wireless features again in Entertainment Mode.

FAQs

This section covers questions you might have while using your product. For further assistance, consult our self-help tool "Knowledge Base". Go to **www.creative.com**, select your region and country, and then select **Support**.

Why is my remote control not responding?

Your remote control's batteries may have depleted. Replace the batteries.

Why can't I hear any sound from my speakers?

Check that

- your speaker system's power is turned on.
- your receiver is powered from the power adapter.
- the volume is not muted. Press the Mute button on your remote control.
- you have connected speakers to your receiver.

Why can't I hear much difference in sound after enabling X-Fi Crystalizer?

X-Fi Crystalizer works most dramatically on sound with many high and low frequencies. Some types of music have mostly mid-range frequencies, so the change may not be as apparent.

Why do I hear stereo music only from my receiver?

Your receiver plays only stereo music. For multichannel surround sound, use the Optical Out jack on your transmitter, if it has one.

What is the best position for stereo speakers when X-Fi CMSS-3D Virtual is enabled?

Good speaker placement can enhance your listening experience, while careless placement can make good audio systems sound bad. Below is our recommendation for stereo speakers.

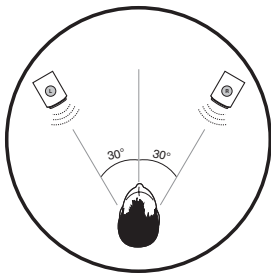

How do I change the wireless zone number of my receivers?

Do the following:

- i. Return the transmitter to factory default settings. See "Returning to factory default settings" on page 16.
- ii. Manually pair the receivers. Follow the steps in "Manual Pairing" on page 12.

General Specifications

Connectivity

- Audio Line Out - 3.5 mm (1/8") Stereo jack
- RCA Audio Line Out jacks

X-Fi Technology (enhanced by transmitter)

- X-Fi Crystalizer
- X-Fi CMSS-3D Virtual

Power Adapter

- Supply Voltage: 5V +/- 5%
- Current: 1 A
- Power: 5 W

Radio Frequency (RF)

- Operating RF range: 2400 - 2483.5 MHz
- Number of RF channels: 3
- RF transmitter power output: 16 dBm (typical)

NOTE You cannot tune the RF channels.

Safety Information

Refer to the following information to use your product safely, and to reduce the chance of electric shock, short-circuiting, damage, fire, hearing impairment or other hazards.

Improper handling may void the warranty for your product. For more information, read the warranty available with your product.

- Do not dismantle or attempt to repair your product.
Refer all servicing to authorized repair agents.
- Do not expose your product to temperatures outside the range of 0°C to 40°C (32°F to 104°F).
- Do not pierce, crush or set fire to your product.
- Keep your product away from strong magnetic objects.
- Do not subject your product to excessive force or impact.
- Do not expose your product to water or moisture.
If your product is moisture-resistant, take care not to immerse your product in water or expose it to rain.

Earphones

- When a conductive apparatus, such as earphones, is used in close proximity with a CRT television or CRT monitor, the latter may emit an electrostatic discharge. The electrostatic discharge can be felt as a static shock. While this static shock is usually harmless, it is good practice to avoid close contact with CRT devices when using earphones.
- Do not listen to audio on your earbuds or headphones at high volume for prolonged periods of time as hearing loss may result. For users in the United States, go to **www.hei.org** for more information.
- Do not listen to your audio device at high volume when driving, cycling or crossing the road, especially in heavy traffic, or in any other traffic condition where such use will hinder safe travel on the roads. We recommend that consumers be extremely cautious when using this device on the road.

Embedded Battery

- Do not attempt to remove the embedded battery.
The product must be disposed of according to local environmental regulations. To replace the battery, return your product to your regional support office. For product service information, go to **www.creative.com**.

Removable Battery

- The battery must be recycled or disposed of properly. Contact local agencies for recycling and disposal information.
- Do not allow metal objects to touch the terminals of your battery.
- If there is leakage, an offensive odor, discoloration or deformation during charging or use, remove the battery and do not use it again. Clean your hands well before touching food or sensitive areas, for example, your eyes.

Bluetooth Product

- Do not turn on or use your product in an airplane.

Regulatory Information

Notice for the USA

FCC Part 15: This equipment has been tested and found to comply with the limits for a Class B digital device, pursuant to Part 15 of the FCC Rules. These limits are designed to provide reasonable protection against harmful interference in a residential installation. This equipment generates, uses and can radiate radio frequency energy and, if not installed and used in accordance with instructions, may cause harmful interference to radio communications. However, there is no guarantee that interference will not occur in a particular installation. If this equipment does cause harmful interference to radio or television reception, which can be determined by turning the equipment off and on, the user is encouraged to try to correct the interference by one or more of the following measures:

- Reorient or relocate the receiving antenna.
- Increase the separation between the equipment and receiver.
- Connect the equipment into an outlet on a circuit different from that to which the receiver is connected.
- Consult the dealer or an experienced radio/TV technician for help.

This device complies with part 15 of the FCC Rules. Operation is subject to the following two conditions:

- 1 This device may not cause harmful interference, and
- 2 This device must accept any interference received, including interference that may cause undesired operation.

CAUTION: To comply with the limits of the Class B digital device, pursuant to Part 15 of the FCC Rules, this device must be installed with computer equipment certified to comply with Class B limits.

All cables used to connect to the computer and peripherals must be shielded and grounded. Operation with non-certified computers or non-shielded cables may result in interference to radio or television reception.

MODIFICATION: Any changes or modifications not expressly approved by the grantee of this device could void the user's authority to operate the device.



WARNING: To satisfy FCC RF exposure requirements for mobile transmitting devices, a separation distance of 20 cm or more should be maintained between the antenna of this device and persons during device operation.

To ensure compliance, operations at closer than this distance is not recommended. The antenna used for this transmitter must not be co-located in conjunction with any other antenna or transmitter.

California Proposition 65 Statement

WARNING: Handling this product may expose you to chemicals known to the State of California to cause cancer and birth defects or other reproductive harm.

Wash hands after handling.

Explanatory Note: California Safe Drinking Water and Toxic Enforcement Act of 1986 (Proposition 65) requires special product labeling for products containing certain chemicals known to the State of California to cause cancer, birth defects or other reproductive harm. Creative has chosen to provide a warning based on its knowledge about the presence of one or more listed chemicals without attempting to evaluate the level of exposure. With Creative's products, the exposure may be below the Proposition 65 level of concern, or could even be zero. However, out of an abundance of caution, Creative has elected to place the Proposition 65 warning on its products.

Déclaration de la Proposition 65 de la Californie

AVERTISSEMENT: La manipulation de ce produit peut vous exposer à des produits chimiques qui sont reconnus par l'État de la Californie comme pouvant provoquer le cancer, des anomalies congénitales ou d'autres effets nuisibles à la reproduction.

Veillez vous laver les mains après l'avoir manipuler.

Note explicative: La Proposition 65 (California Safe Drinking Water and Toxic Enforcement Act of 1986) de la Californie sur les matières dangereuses et l'eau potable exige un étiquetage spécial pour les produits contenant certains produits chimiques qui sont reconnus par l'État de la Californie comme pouvant provoquer le cancer, des anomalies congénitales ou d'autres effets nuisibles à la reproduction. Creative a choisi d'inclure une mise en garde s'appuyant sur sa connaissance de la présence d'un ou de plusieurs de ces produits chimiques sans essayer d'en évaluer le niveau d'exposition. Pour les produits de Creative, le niveau d'exposition peut être

inférieur au niveau critique établi par la Proposition 65 ou même être nul. Néanmoins, par souci extrême de prudence, Creative a choisi de placer l'avertissement de la Proposition 65 sur ses produits.

Notice for Canada

This Class B digital apparatus complies with Canadian ICES-003.

Operation is subject to the following two conditions:

- 1 This device may not cause harmful interference, and
- 2 This device must accept any interference received, including interference that may cause undesired operation.

Cet appareil numérique de la classe B est conforme à la norme NMB-003 du Canada.

CANADIAN CLASS B STATEMENT: This digital device does not exceed the Class B limits for radio noise emissions from digital apparatus as set out in the interference-causing equipment standard entitled "Digital Apparatus," ICES-003 of the Department of Communications.

Cet appareil numérique respecte les limites de bruits radioélectriques applicables aux appareils numériques de Class B prescrites dans la norme sur le matériel brouilleur. "Appareils Numériques," NMB-003 édictée par le ministre des Communications.

MODIFICATION: Any changes or modifications not expressly approved by the grantee of this device could void the user's authority to operate the device.

Toute modification non approuvée explicitement par le fournisseur de licence de l'appareil peut entraîner l'annulation du droit de l'utilisateur à utiliser l'appareil.

Information in this document is subject to change without notice and does not represent a commitment on the part of Creative Technology Ltd. No part of this manual may be reproduced or transmitted in any form or by any means, electronic or mechanical, including photocopying and recording, for any purpose without the written permission of Creative Technology Ltd.

Copyright © 2008 Creative Technology Ltd. All rights reserved. The Creative logo, Sound Blaster, MovieWorks, X-Fi, CMSS, and Crystalizer are trademarks or registered trademarks of Creative Technology Ltd. in the United States and/or other countries. iPod is a registered trademark of Apple Inc., registered in the U.S. and other countries.

Version 1.0

February 2009