

CREATIVE

SoundBLASTER

R5



User's Guide

Model No: SB1590

Introduction

Congratulations on your purchase of Sound Blaster® R5/E5! This portable audio recording hub and DAC (Digital-to-Analog Converter) features powerful noise reduction microphones that record clean, high quality audio directly to smart devices or PCs and Macs. The built-in powerful SoundCore3D™ sound and voice processor with SBX® Pro Studio™ technology was designed to perfectly deliver our legendary microphone reverb engine and produce an amazing cinematic audio playback experience. The Sound Blaster R5/E5 provides support for high performance headphones for a studio-grade listening experience and it also comes with dual headphone jacks for easy music sharing. It also boasts NFC for one-touch *Bluetooth*® pairing.

Package Checklist

Your Sound Blaster R5/E5 package comes with the following:

- The Sound Blaster R5/E5
- Micro-USB 2.0 cable
- 3.5 mm (1/8") stereo analog cable
- 3.5 mm (1/8") clip microphone
- Two elastic bands
- Desk stand
- Quick Start leaflet

Minimum System Requirements

For Windows® OS

- Intel® Core™2 Duo or AMD equivalent processor, 2.8 GHz or faster recommended
- Intel, AMD or 100% compatible motherboard
- Microsoft® Windows 8.1 32-bit or 64-bit, Windows 8 32-bit or 64-bit, Windows 7 32-bit or 64-bit, Windows Vista® 32-bit or 64-bit (Service Pack 1 or higher)
- 1 GB RAM
- >600 MB of free hard disk space
- Available USB 2.0 port (High Speed requires driver)

For Mac® OS

- Intel® Core™2 Duo or AMD® equivalent processor, 2.8 GHz or faster recommended
- Mac OS X® 10.6.8 or higher
- 1 GB RAM
- >600 MB of free hard disk space
- Available USB 2.0 port

For mobile device

- iPhone® / iPad® running iOS 5.1.1 or higher
- Android™ phone / tablet running Android 2.3 or higher for *Bluetooth*
- Android phone / tablet running Android 4.1 or higher for USB Host Audio Streaming*
* These devices' firmware must implement AOA2 protocol so as to support USB Host Audio Streaming

Registering Your Product

Registering your product ensures you receive the most appropriate service and product support available. You can register your product during installation or at www.creative.com/register. Please note that your warranty rights are not dependent on registration.

More Help

For the latest news and products for the Sound Blaster, please visit www.soundblaster.com. The site also includes information on making purchases, technical help and the latest software updates.

Using Creative Software AutoUpdate

Locating, downloading and installing updates for your Creative products is now simpler and faster with the web-based Creative Software AutoUpdate system.

When you connect to Creative Software AutoUpdate via the Internet, the website will analyze your computer system to determine your operating system, language and which Creative products are connected to your system.

When this analysis is completed, you will then be given a list of only the most relevant software updates for your connected products. The files can then be retrieved and installed.

To learn more about the Creative Software AutoUpdate, please visit www.soundblaster.com/support.

Note:

*First-time users of Creative Software AutoUpdate may be prompted to authorize the download of a browser component required for system analysis. Check to ensure that this content is signed by Creative Labs, Inc., then click the **Yes** button.*

Please ensure that all your Creative products are connected and installed on the same computer running Creative Software AutoUpdate.

About Your Hardware

The Sound Blaster R5/E5 has input and output jacks to enable connection to various devices while controls on the side give you basic control over your audio device.

Sound Blaster R5/E5

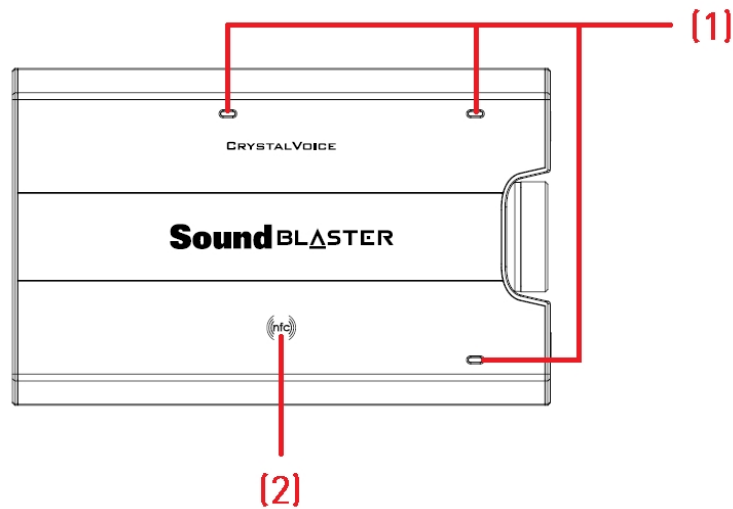

	Control / Indicator	Description
1	Microphones	Built-in stereo microphones with horizontal or vertical orientation sensor. Note: <i>Only one pair of microphones will be enabled at a time, depending on the orientation of the device.</i>
2	NFC receptor	Tap your NFC-enabled device on the Sound Blaster R5/E5 to instantly pair and connect.

Controls & Indicators

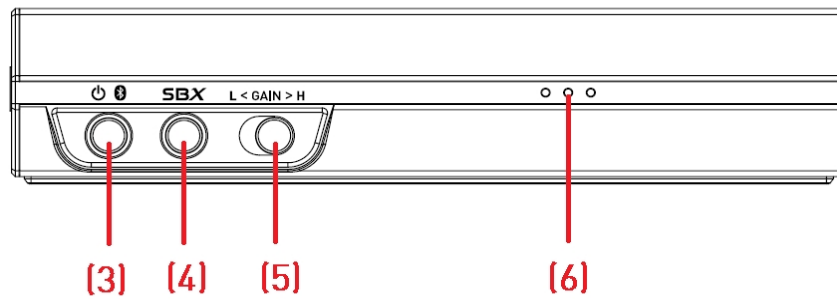

	Control / Indicator	Description
3	Power / <i>Bluetooth</i> button and indicator	<p>Power / <i>Bluetooth</i> button</p> <ul style="list-style-type: none"> • Power On – Press and hold 1 sec • <i>Bluetooth</i> pairing – Press and hold 2 sec • Power Off – Press and hold 4 sec <p>Indicator</p> <ul style="list-style-type: none"> • White: Power ON • Blue (blinking): <i>Bluetooth</i> discovery/pairing mode • Blue: <i>Bluetooth</i> connected • Off: Power OFF
4	SBX / Call button and indicator	<p>SBX button</p> <ul style="list-style-type: none"> • Toggles SBX Pro Studio audio enhancements ON/OFF. <p>During an incoming call</p> <ul style="list-style-type: none"> • Press once to answer an incoming call. • Press again to end a call. <p>Indicator</p> <ul style="list-style-type: none"> • White: SBX Pro Studio ON • White (blinking): Call in progress • Off: SBX Pro Studio OFF
5	Gain switch (Low / High)	<p>Switches the headphones gain level.</p> <ul style="list-style-type: none"> • Low: For headphones with low impedance or high sensitivity (33 ~ 300 ohms). • High: For headphones with high impedance or low sensitivity (300 ~ 600 ohms).
6	Power / Battery indicator	<p>The three white LEDs show the power status (ON or OFF) of the Sound Blaster R5/E5 and its battery level.</p> <ul style="list-style-type: none"> • Lighted: Power ON. The lighted LEDs show the current battery level. • Flashing: Battery is charging. The flashing LED shows the charge level. • Off: Power OFF.

Input / Output Jacks

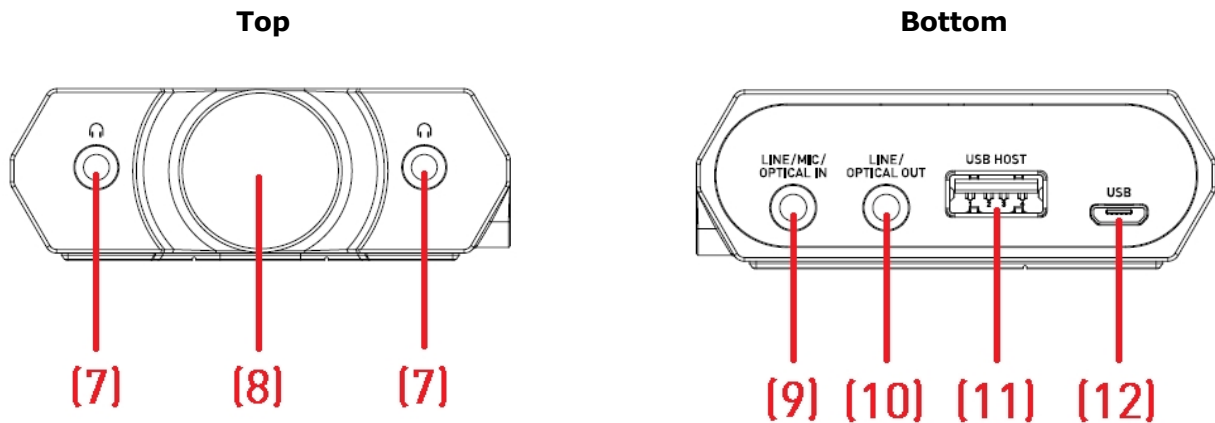

	Jack / Control	Description
7	Headphone jacks	Connects to stereo headphones with a 3.50 mm (1/8-inch) plug.
8	Volume control knob	Adjusts the audio output volume. Turn clockwise: Increase volume Turn anti-clockwise: Decrease volume Press once: Mute or unmute the volume
9	Line / Mic / Optical In jack	Connects to line-level sources (smartphones, tablets, MP3 players) with a 3.50 mm (1/8-inch) plug. OR Connects to microphones with a 3.50 mm (1/8-inch) plug. OR Connects to optical digital sources (video game consoles, DVD players, AV receivers) with a Mini-TOSLINK plug.
10	Line / Optical Out jack	Connects to powered analog speakers with a 3.50 mm (1/8-inch) plug. OR Connects to optical digital devices (video game consoles, DVD players, AV receivers) with a 3.50 mm (1/8-inch) Mini-TOSLINK plug.
11	USB Host port	Connects to an iPhone/iPad for audio playback or recording. OR Connects to an Android phone/tablet for audio playback. OR Connects to a USB microphone (Sound Blaster R1). OR For charging external device, e.g. phone, MP3 player, etc.
12	USB	

	Jack / Control	Description
12	USB port	<p>Connects to USB ports of PC/Mac for audio playback or recording.</p> <p style="text-align: center;">OR</p> <p>Connects to an Android phone/tablet via an OTG cable for audio recording.</p> <p style="text-align: center;">OR</p> <p>Alternatively, you may connect it to the power socket via a USB power adapter to charge it.</p>

Setting Up Your Audio Device

Step 1: Charging your Sound Blaster R5/E5

Connect your Sound Blaster R5/E5 directly to a USB port on your computer.

You can also connect to a wall outlet using USB power adapter* (not included).

* DC 5V, 1 A

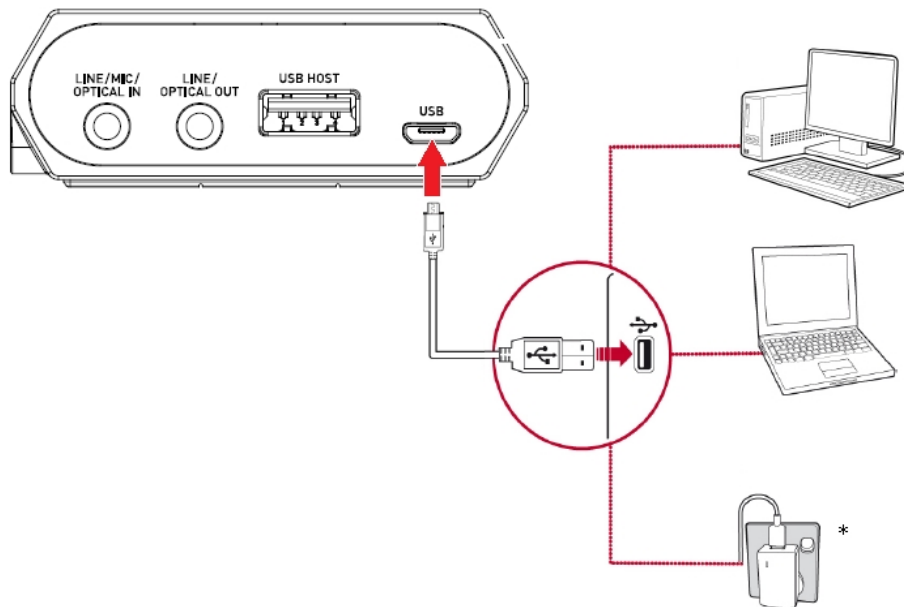

Charge your Sound Blaster R5/E5 for approximately 3 to 4 hours.

It is recommended that you charge it for at least 8 hours before it is used for the first time.

Note:

Lithium-ion battery life may suffer when it is constantly fully depleted or overexerted at low voltage. It is a good practice to keep the battery well charged.

Sound Blaster R5/E5 can be charged even when it is powered off. If a power source is present, it will go into charging mode 3 seconds after it is powered off.

Step 2: Turning On Sound Blaster R5/E5

Press the **Power / Bluetooth** button to turn on Sound Blaster R5/E5.

- Power On – Press and hold 1 sec
- *Bluetooth* pairing – Press and hold 2 sec
- Power Off – Press and hold 4 sec

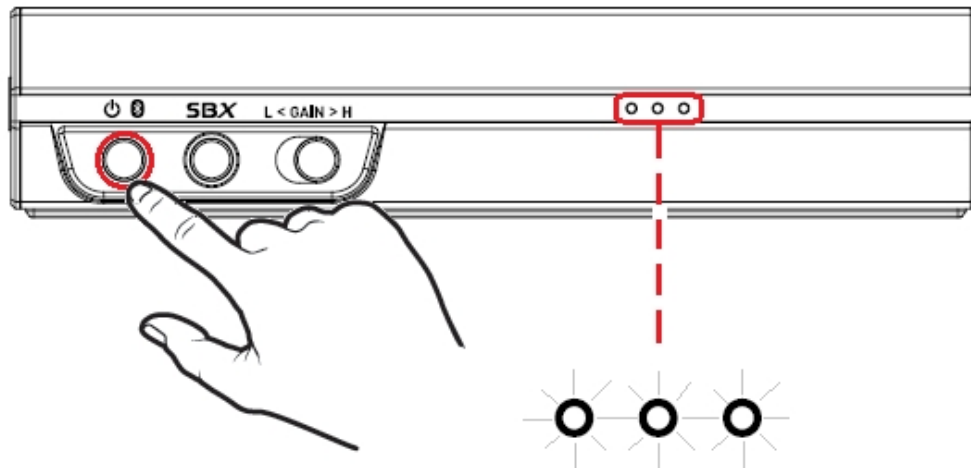

Battery level indication

In On mode, the three white LEDs light up according to the battery level of your Sound Blaster R5/E5.



When charging during Off mode, the LEDs will light up according to the battery level, and the flashing LED shows the charge level. All LEDs will turn off when fully charged.

Step 3: Connecting to an Audio Source

One-touch pairing with NFC

You may pair your NFC-enabled devices with the Sound Blaster R5/E5 with a single tap using NFC technology. Simply follow these steps to connect them.

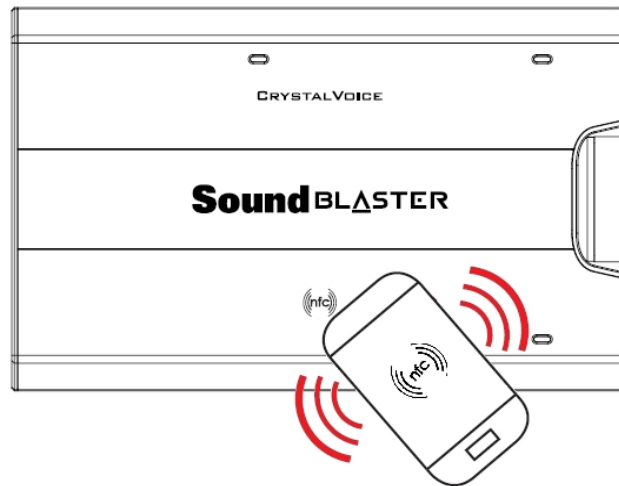

Action	LED Status	Device Status
1	Turn ON the NFC feature on your device. And touch your device on the NFC logo on Sound Blaster R5/E5. If prompted "Are you sure you want to pair the <i>Bluetooth</i> device?", tap "Yes".	<i>Bluetooth</i> indicator lights up in blue. Device paired automatically. Ready to stream music.

Note:

Be sure that your phone is NFC-enabled and find out where the NFC sensor is located on your phone. For more information, refer to the User Guide of your phone.

To disconnect, tap your device with the Sound Blaster R5/E5 again.

Manual *Bluetooth* pairing

To enjoy your favorite music from your *Bluetooth* devices, simply follow these steps to connect them.

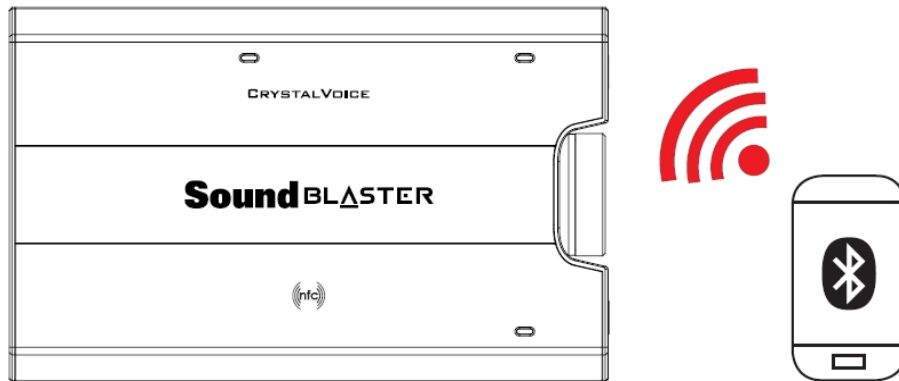

Action		LED Status	Device Status
1	Press and hold Power / Bluetooth button for 2 seconds.	<i>Bluetooth</i> indicator blinks in blue.	Pairing mode. Ready to be paired with new device.
2	Turn ON the <i>Bluetooth</i> feature on your device. Search and select " Sound Blaster R5/E5 ". If password is required, enter 0000 and connect to it.	<i>Bluetooth</i> indicator lights up in blue.	Ready to stream music.

Note:

If no pairing is done within 60 seconds, Bluetooth pairing mode will be deactivated.

Bluetooth pairing between these devices may vary depending upon the model type. Consult your device's manual on how to pair.

You can only connect one Bluetooth device at a time.

Connecting to a computer via USB

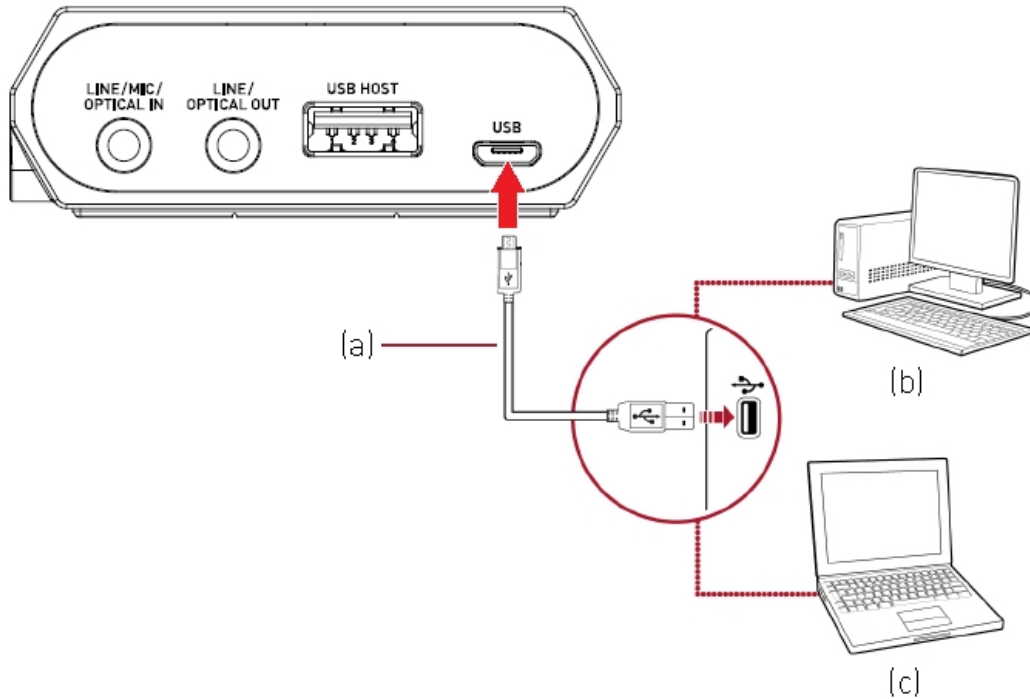

(a) Micro-USB cable

(b) Desktop

(c) Laptop

Note:

Connecting the Sound Blaster R5/E5 to a USB hub is not recommended.

Setting the Sound Blaster R5/E5 as the default audio device

For Windows

1. Go to **Control Panel** and click **Sound**.
2. Click the **Playback** tab, select **Sound Blaster R5/E5**, then click the **Set Default** button.
3. Click the **Recording** tab, select the required **Sound Blaster R5/E5** recording device, then click the **Set Default** button.

For Mac

1. Go to **System Preferences** and click **Sound**.
2. Click the **Output** tab, then select **Sound Blaster R5/E5**.
3. Click the **Input** tab, then select the required **Sound Blaster R5/E5** recording device.

Connecting to an Android device via USB

To connect an Android device via USB, use an On-The-Go cable*.

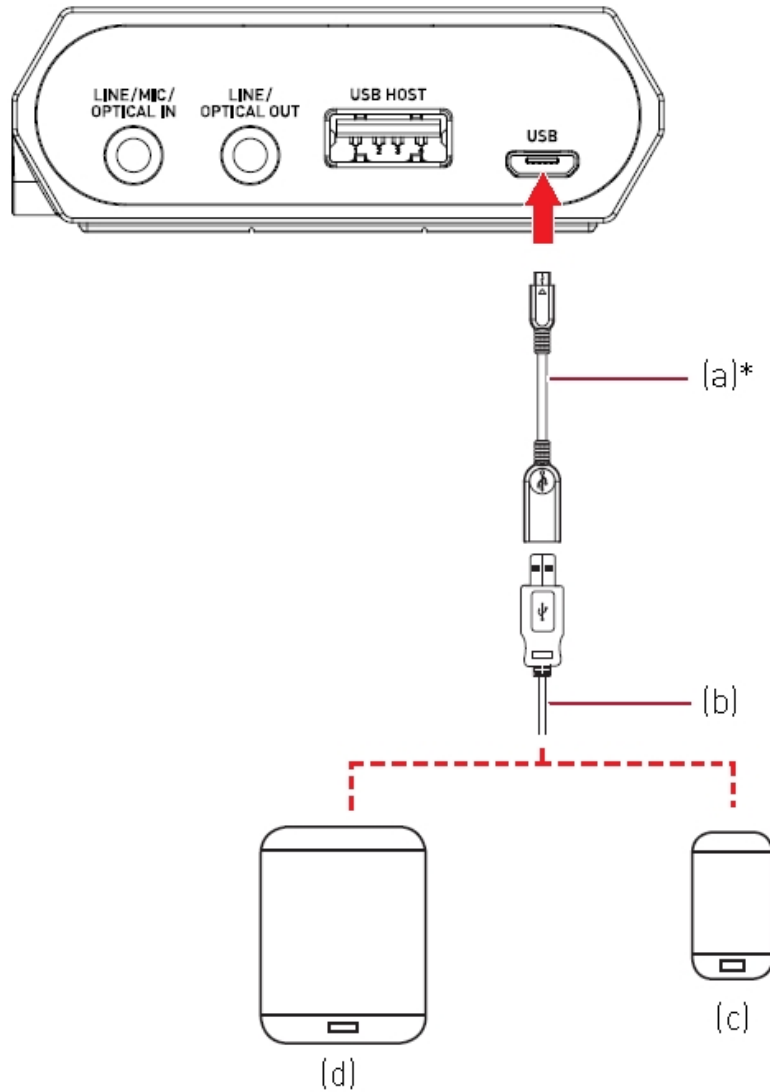

- (a) On-The-Go cable*
- (b) USB cable
- (c) Android phone
- (d) Android tablet

Note:

* The On-The-Go cable is available separately.

On-The-Go cable lets you connect your device to the Sound Blaster R5/E5 using the USB cable that came with your device.

Connecting to a mobile device via USB Host

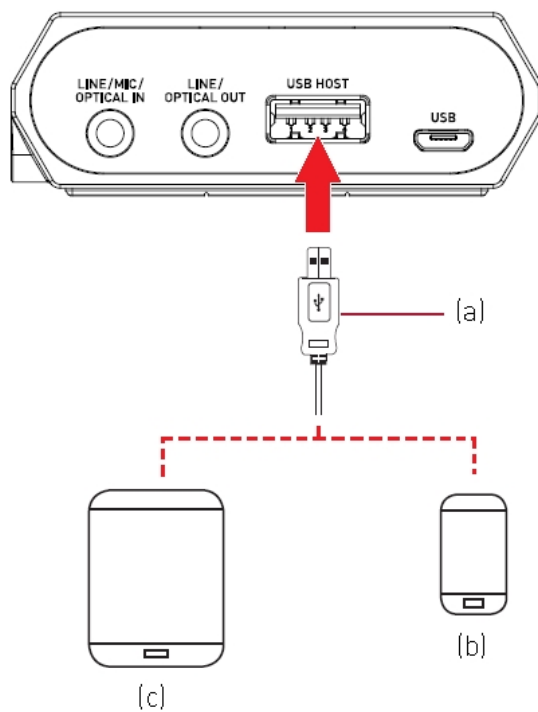

- (a) USB cable
- (b) Smartphone
- (c) Tablet

Connecting to line-in sources (e.g. MP3 player, CD player)

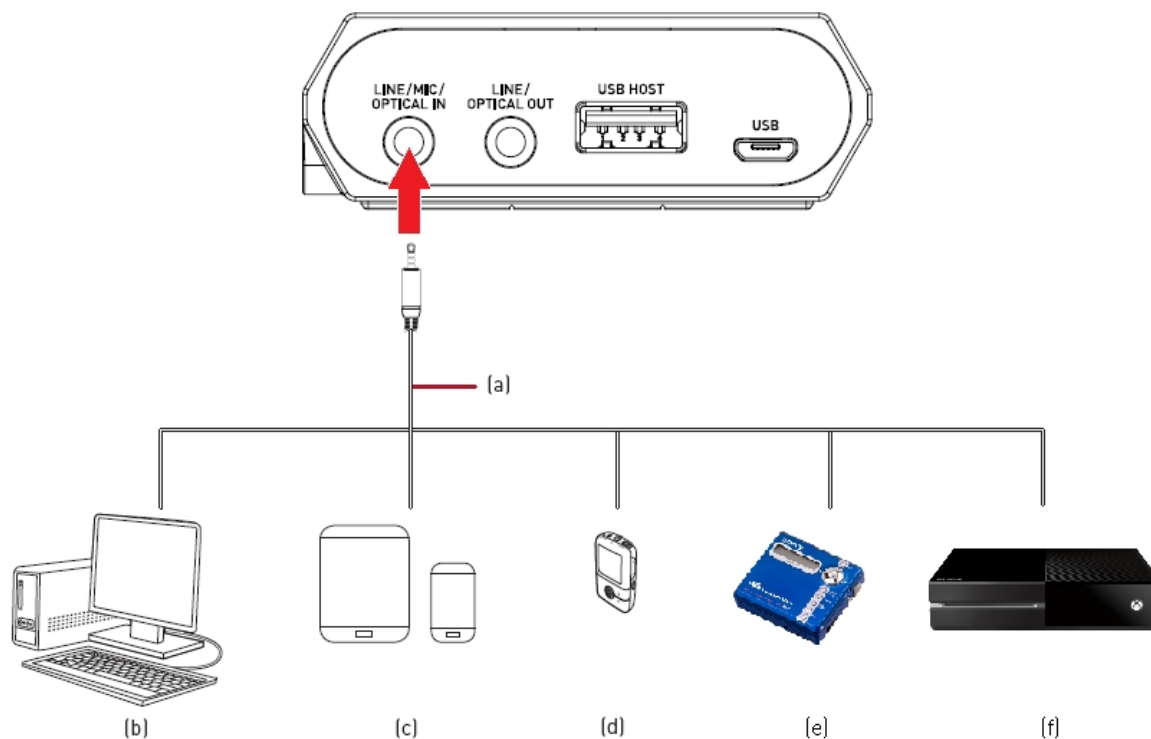

- (a) 3.5 mm (1/8") stereo analog cable
- (b) PC/Mac
- (c) Tablet/Smartphone
- (d) Portable media player
- (e) External recording devices
(DAT players, CD players, etc.)
- (f) Game console

Connecting to Optical-In Sources (e.g. DVD player, TV set)

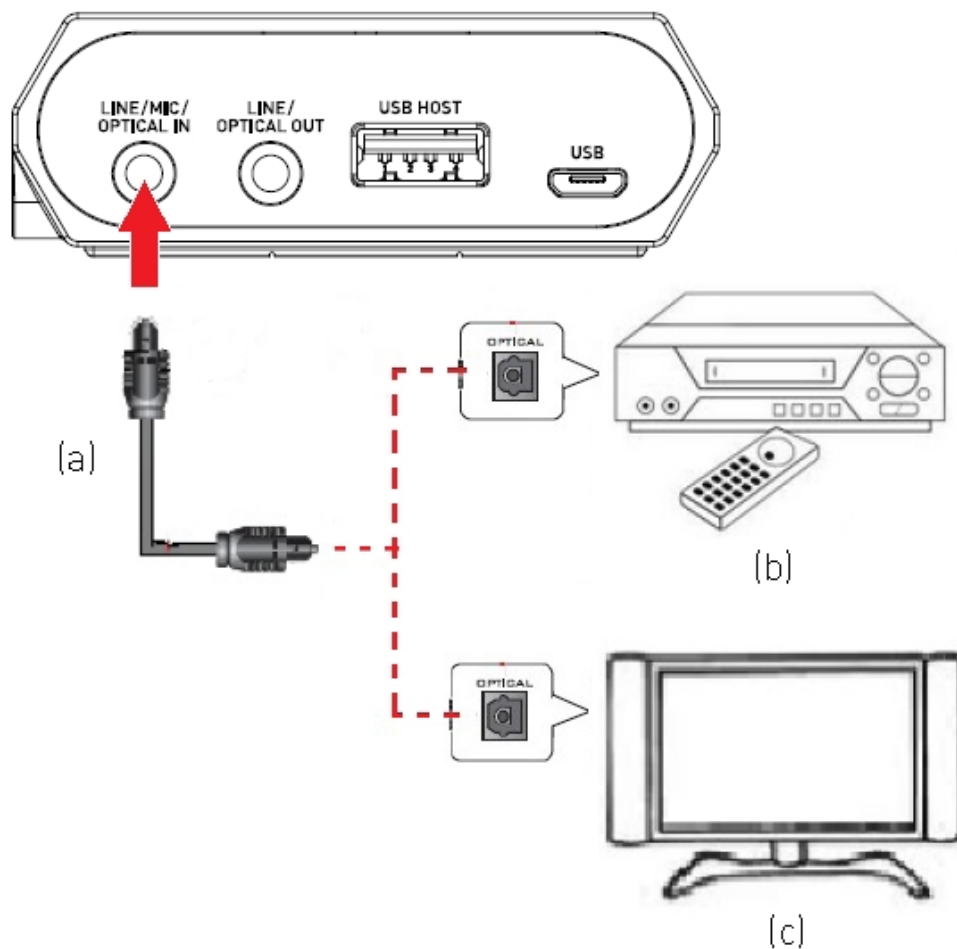

- (a) Mini-TOSLINK cable
(not included)
- (b) DVD player
- (c) TV set

Step 4: Connecting to Headphones / Speakers / Microphone

Connecting to headphones

CAUTION:

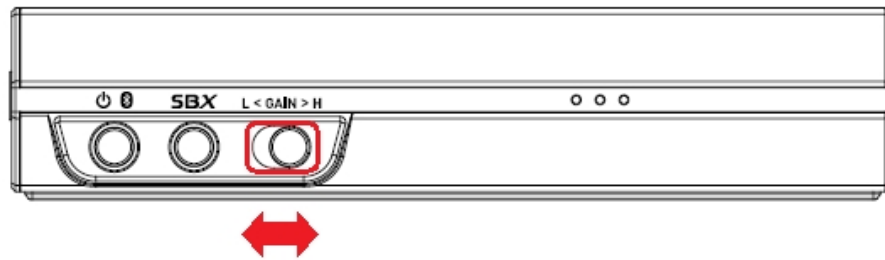

Set the appropriate gain level (L or H) before connecting your headphones to the Headphone jack to prevent damaging your headphones.

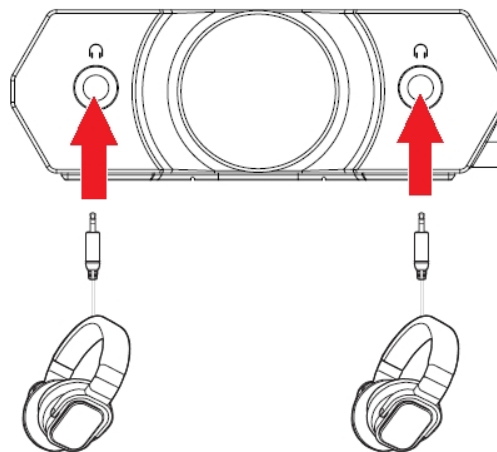

Connecting to speakers

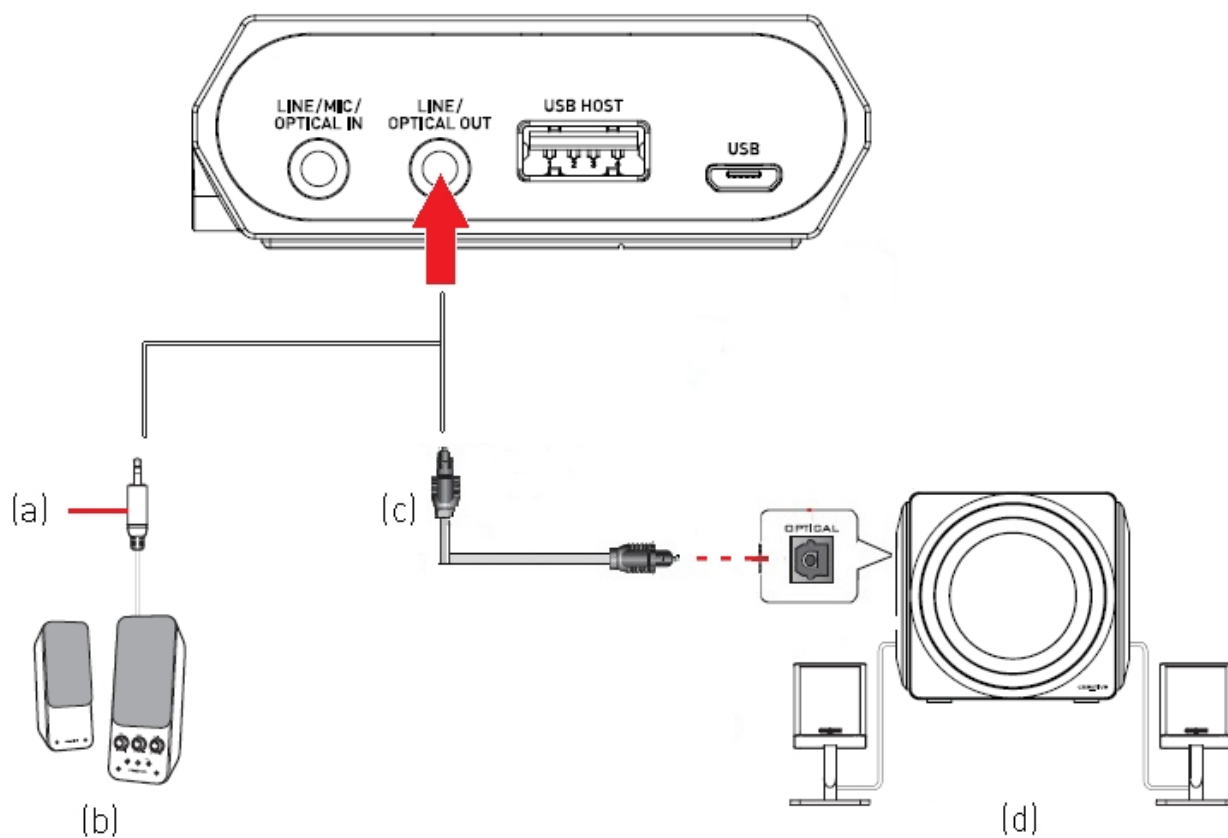

- (a) 3.5 mm 2-channel audio cable
(available separately)
- (b) Analog speakers
- (c) Mini-TOSLINK cable
(not included)
- (d) Digital speakers

Note:

The Line/Optical Out jack is disabled if a device is connected to the Headphone jacks.

Connecting to microphones

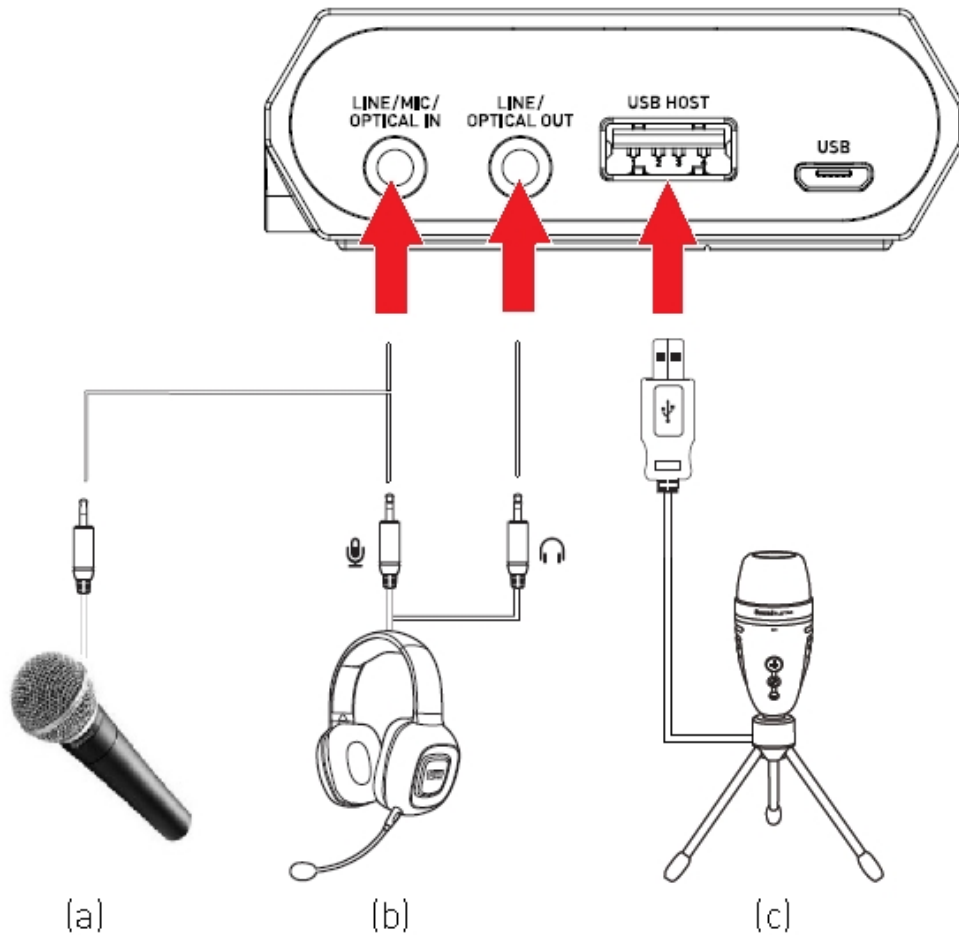

- (a) Microphone
- (b) Headset
- (c) Sound Blaster R1
(available separately)

To use an external microphone

For Windows

1. Go to **Control Panel** and click **Sound**.
2. Click the **Recording** tab, select **Sound Blaster R5/E5 (External Mic)** or **Sound Blaster R1**, then click the **Set Default** button.

For Mac

1. Go to **System Preferences** and click **Sound**.
2. Click the **Input** tab, then select **Sound Blaster R5/E5 (External Mic)** or **Sound Blaster R1**.

Note:

You can only use one microphone at a time.

The Sound Blaster R1 is available separately.

Installing and Uninstalling Software

To take full advantage of your Sound Blaster R5/E5 audio device, you need to install device drivers and applications. At times, you may also need to uninstall some or all of the device drivers and applications to correct problems, change configurations, or upgrade outdated drivers or applications. To learn how to do so in all supported Windows and Mac operating systems, consult the following sections:

- Installing Drivers and Applications
- Uninstalling Drivers and Applications
- Installing the Mobile App

Installing Drivers and Applications

Ensure that your audio device is connected before proceeding. For instructions on connecting your audio device, consult your Quick Start leaflet.

After you have connected your audio device, turn on your computer. Windows automatically detects your audio device and searches for device drivers.

For Windows OS

1. Using a standard web browser, visit www.creative.com/support.
2. Locate **Sound Blaster R5/E5** and the software package for your Windows operating system.
3. Download this package into your local hard disk.
4. Locate and launch the software package.
5. Follow the on-screen instructions to complete the installation.
6. When prompted, restart your computer.
7. Launch the application by locating and clicking **Sound Blaster R5/E5 Control Panel**.

For Mac OS

1. Using a standard web browser, visit www.creative.com/support.
2. Locate **Sound Blaster R5/E5** and the software package for your Mac OS.
3. Download this package into your local hard disk.
4. Double-click the downloaded file to uncompress it.
5. Double-click the uncompressed DMG file.
6. Double-click the **Install** icon and follow the subsequent on-screen instructions to complete the installation.
7. Launch the **Sound Blaster R5/E5 Control Panel** from the **Applications > Creative > Sound Blaster E-Series** folder.

Note:

Depending on your operating system, model and software version, the user interface or color theme may differ.

Uninstalling Drivers and Applications

In the event that an uninstallation is required (such as for upgrades), please follow the following procedure.

Before you begin, close all running audio applications. Applications that are still running during uninstallation will not be removed.

For Windows OS

1. From the **Control Panel**, click **Uninstall a program**.
2. Select Sound Blaster R5/E5.
3. Click the **Uninstall** button or option.
If the **User Account Control** dialog box appears, click the **Continue** button.
4. Click the **Yes** button.
5. When prompted, restart your computer.

For Mac OS

1. Click **Applications > Creative > Creative Uninstaller**.
2. Select Sound Blaster R5/E5.
3. Click the **Uninstall** button.
4. Follow the on-screen instructions.

Installing the Mobile App

Sound Blaster Central (for iOS and Android)

Sound Blaster R5/E5 comes with the Sound Blaster Central mobile application, that supports both iOS and Android OS, for you to customize your audio – you now have total control right from the palm of your hand. Download Sound Blaster Central from the Apple App Store or Google Play Store.

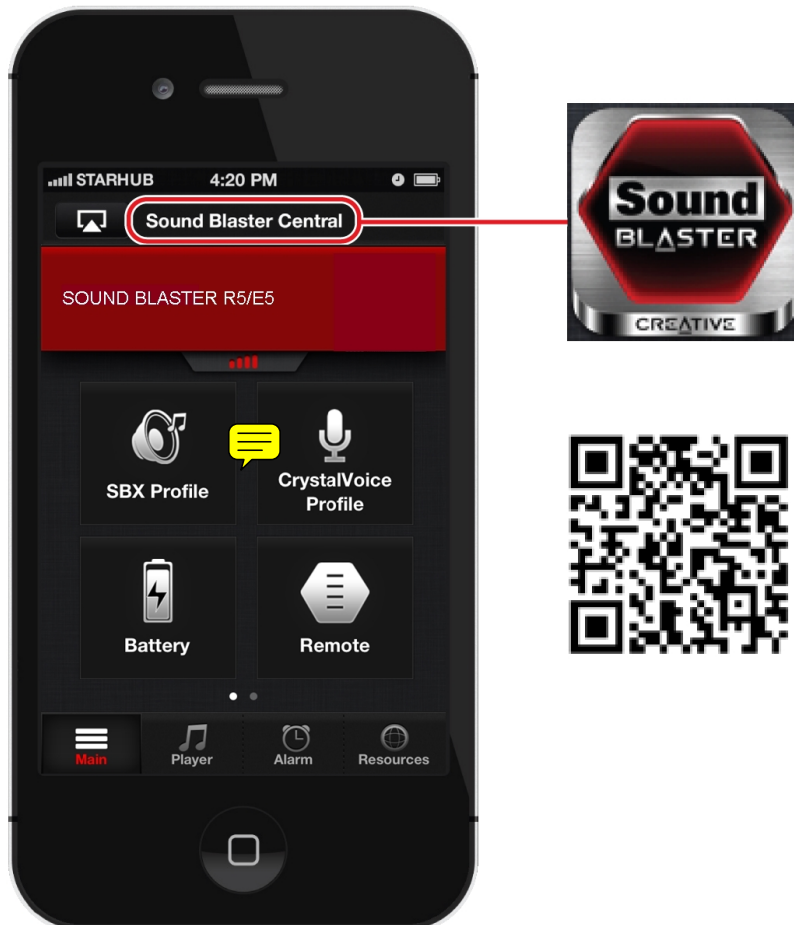

Using Your Audio Device

Step 1: Adjusting the volume

WARNING:

- Set the volume control at minimum level before connecting headphones or speakers.
- Do not listen to audio at high volumes for prolonged periods of time to avoid impairing your hearing.

Adjust the volume to a comfortable level using the volume control.

You can also adjust or mute the volume using:

- Your connected device
- Sound Blaster R5/E5 Control Panel
- Sound Blaster Central mobile application

Note:

If you mute the volume on your connected device or in the software applications, you will not hear any sound output even if the volume control is set to the maximum.

Step 2: Using your Sound Blaster R5/E5

Your Sound Blaster R5/E5 works seamlessly with many external devices to perform different tasks:

- Playing audio
- Answering and ending calls
- Recording audio

Note:

The Line/Optical Out jack is disabled if a device is connected to the Headphone jacks.

Playing audio from a *Bluetooth* device

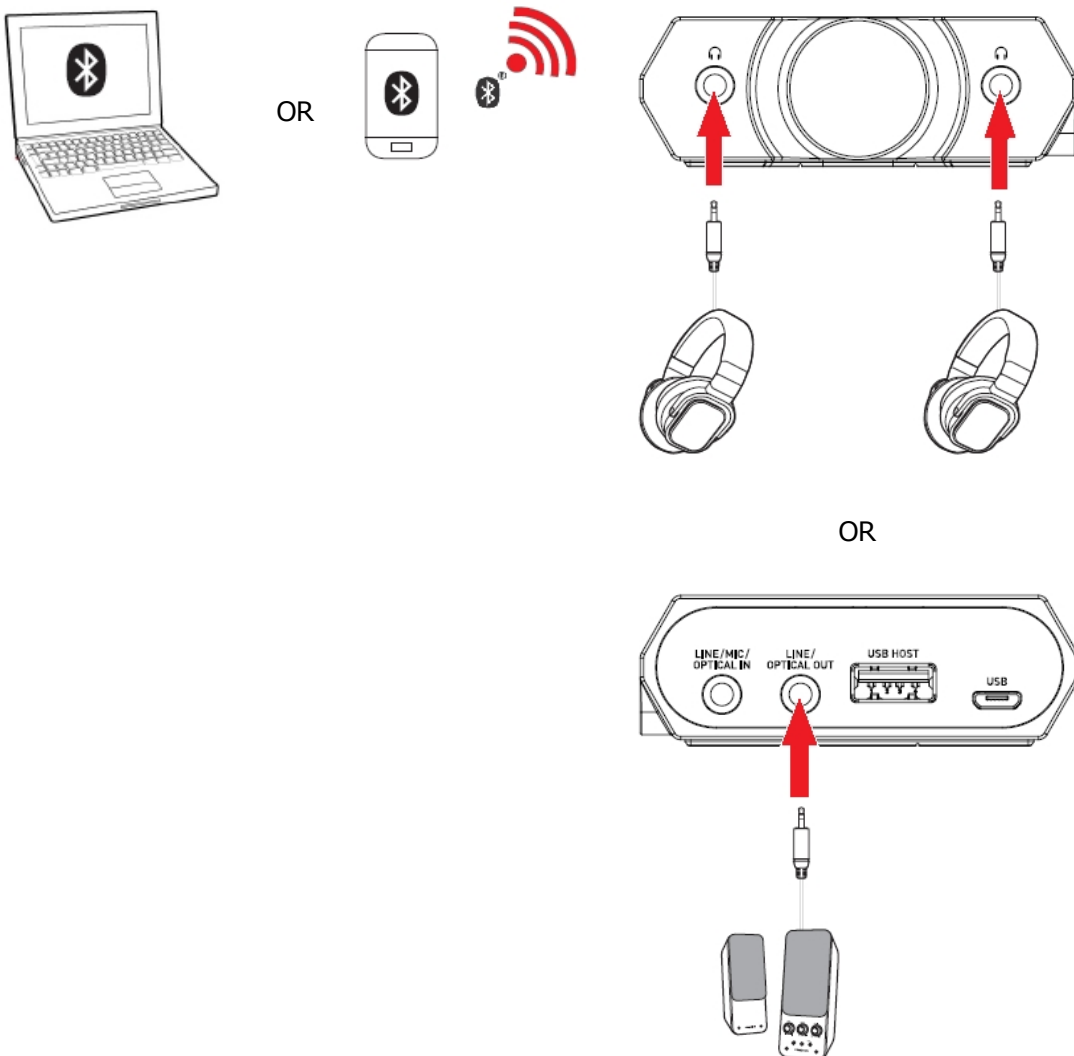

Note:

*Customize and enhance your audio playback via Bluetooth with the Sound Blaster Central mobile application or Sound Blaster R5/E5 Control Panel software. See **Installing and Uninstalling Software**.*

Playing audio from a computer/mobile device via USB

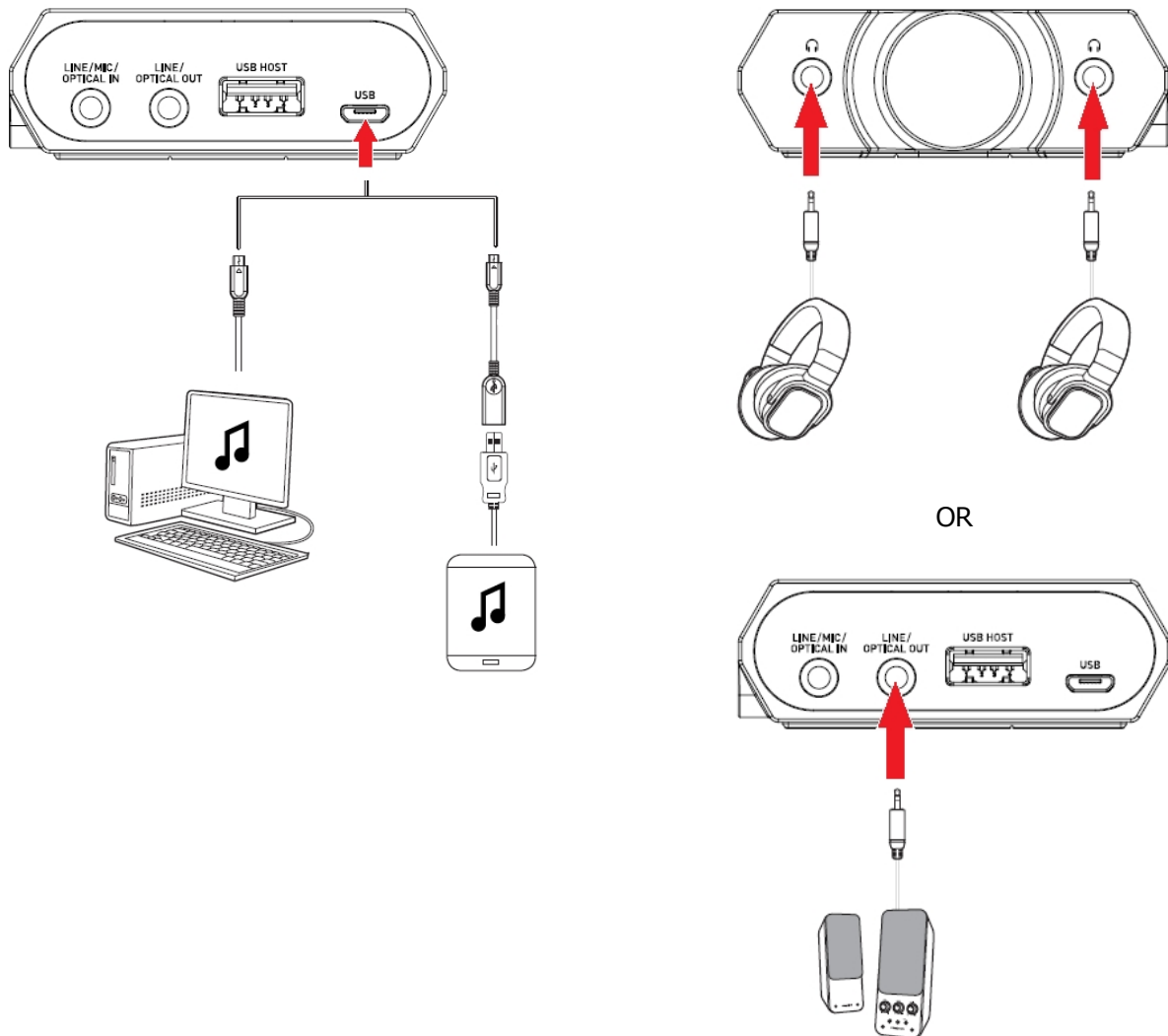

Note:

Enhance audio playback with SBX Pro Studio enhancements such as immersion control, dynamic range restoration, low-frequency boost, dialog boost, and automatic volume levelling. See **Using the Creative Software Suite – SBX Pro Studio Settings**.

Playing audio from a mobile device via USB host

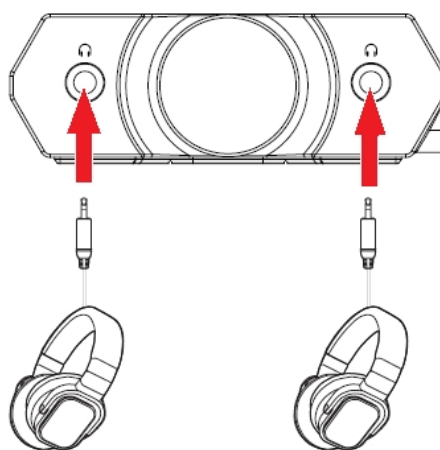
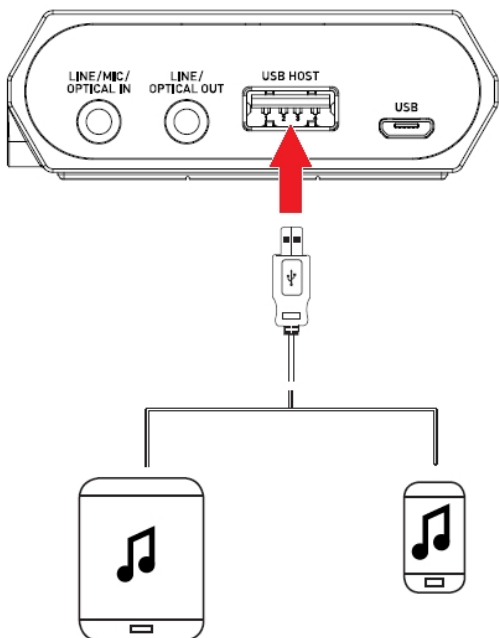

OR

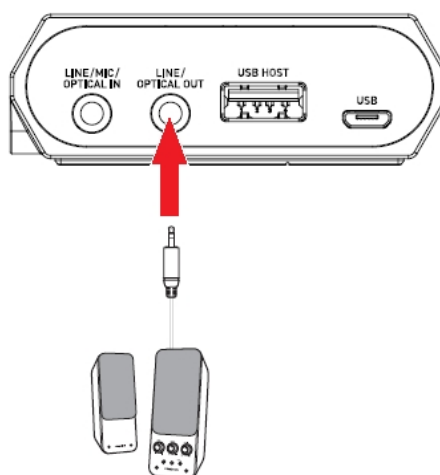

Playing audio from a line-in/optical-in device

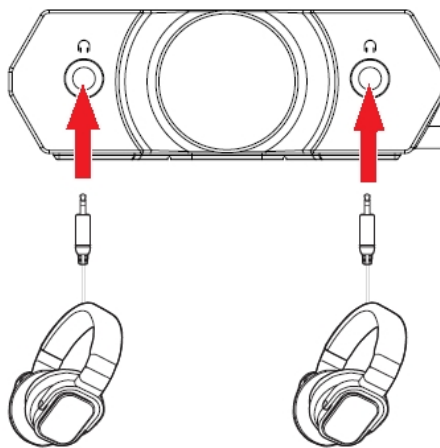
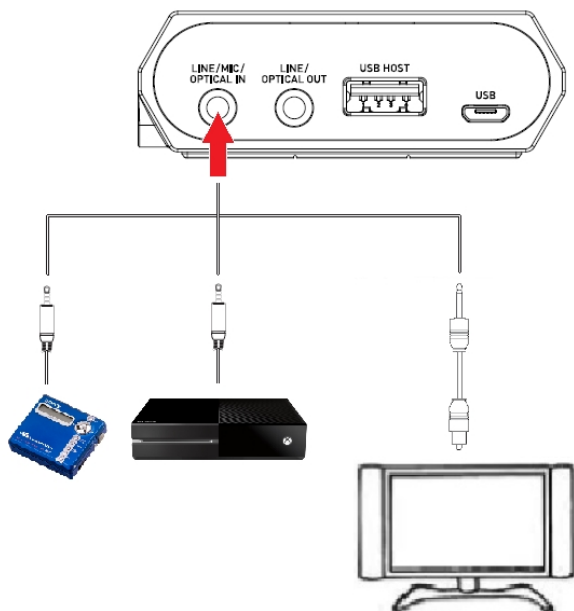

OR

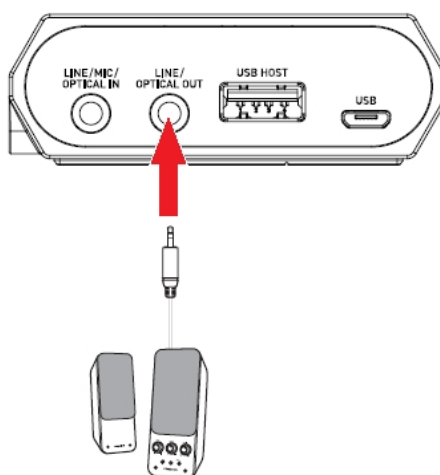

Answering and ending calls

Mobile communication

When there's an incoming call, the call takes precedence over audio playback – playback stops and the ringtone will be heard.

Press the **SBX** button once to answer the call. Press again to end the call.

The music will resume after the call has ended.

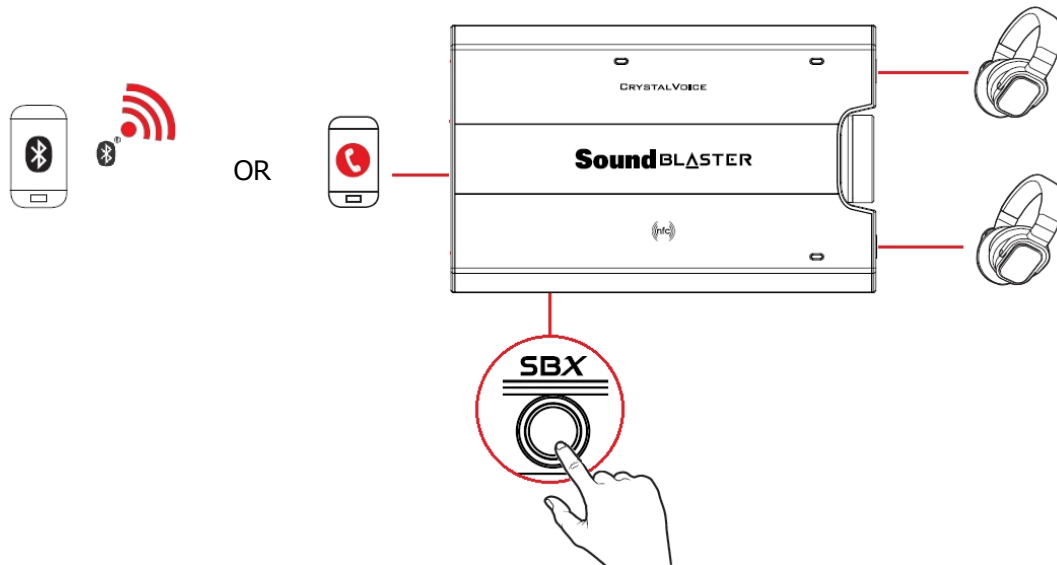

Desktop communication

Use the Sound Blaster R5/E5 to enjoy outstanding acoustic performance in popular VoIP applications like Ventrilo[®] and TeamSpeak[®]. Hear and be heard clearly by teammates during multiplayer games to get the tactical edge. You may choose to morph your voice with special effects with the VoiceFX too! See **Using the Creative Software Suite**.

If the device is connected to a computer, click on the answer call button prompted on the computer screen to enter voice communication.



Note:

If two headphones are connected, you will be able to listen to the call on both headphones.

*CrystalVoice enhancements help to further this experience by enhancing the clarity of communications. See **Using the Creative Software Suite – CrystalVoice Settings**.*

Recording audio to a mobile device

You can record audio to your mobile device using the built-in microphones of the Sound Blaster R5/E5, or an external microphone connected to the Sound Blaster R5/E5.

Use a voice recording application on your mobile device to record audio.

For Android, a third party app such as "USB Audio Recorder PRO" must be installed on your device to use this feature.

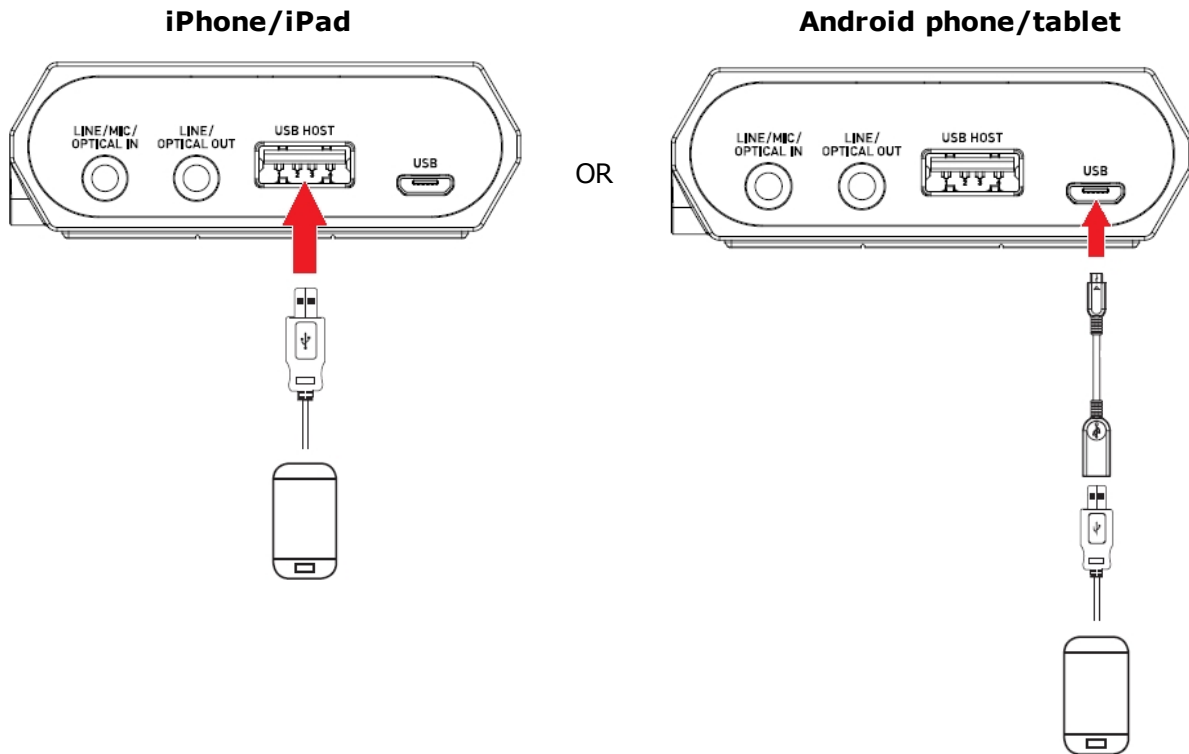

Microphone array orientation

The built-in stereo microphones with horizontal or vertical orientation sensor creates a beamforming microphone array that works together with CrystalVoice technology to ensure crystal clear recording.

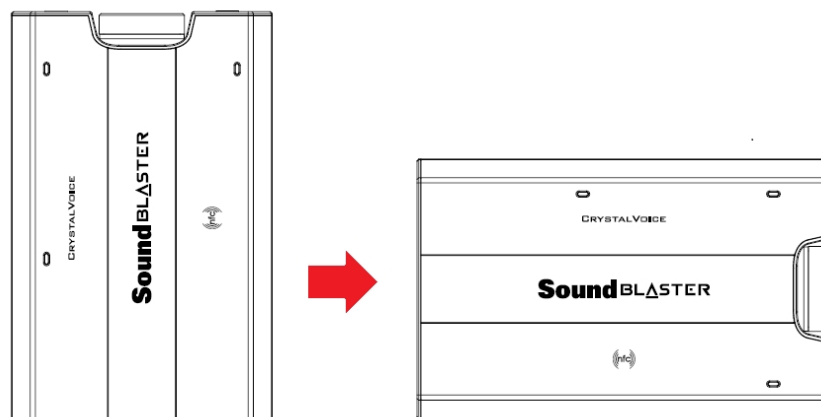

Note:

The built-in microphones will be disabled automatically when an external microphone is connected.

Recording audio to a computer

Easily record audio on your computer with the built-in microphones of the Sound Blaster R5/E5, or an external microphone connected to the Sound Blaster R5/E5.

Use a voice recording application on your computer to record audio.

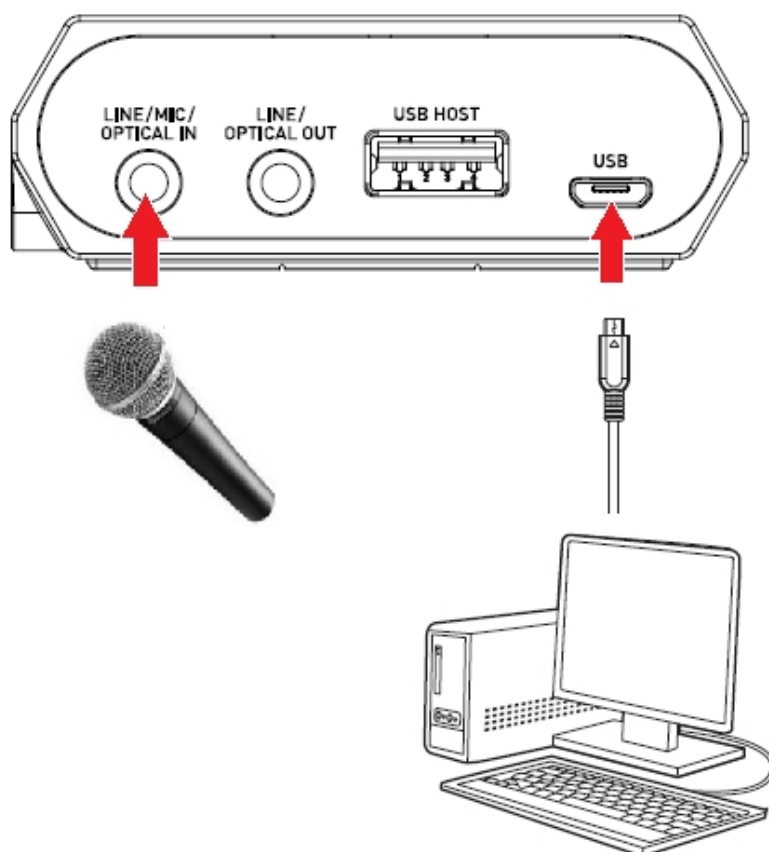

Note:

The built-in microphones will be disabled automatically when an external microphone is connected.

Recording line-level audio to a mobile device or computer

You can record audio from a line-in source (game console, DVD player, TV set) and store them in your mobile or computer via the Sound Blaster R5/E5.

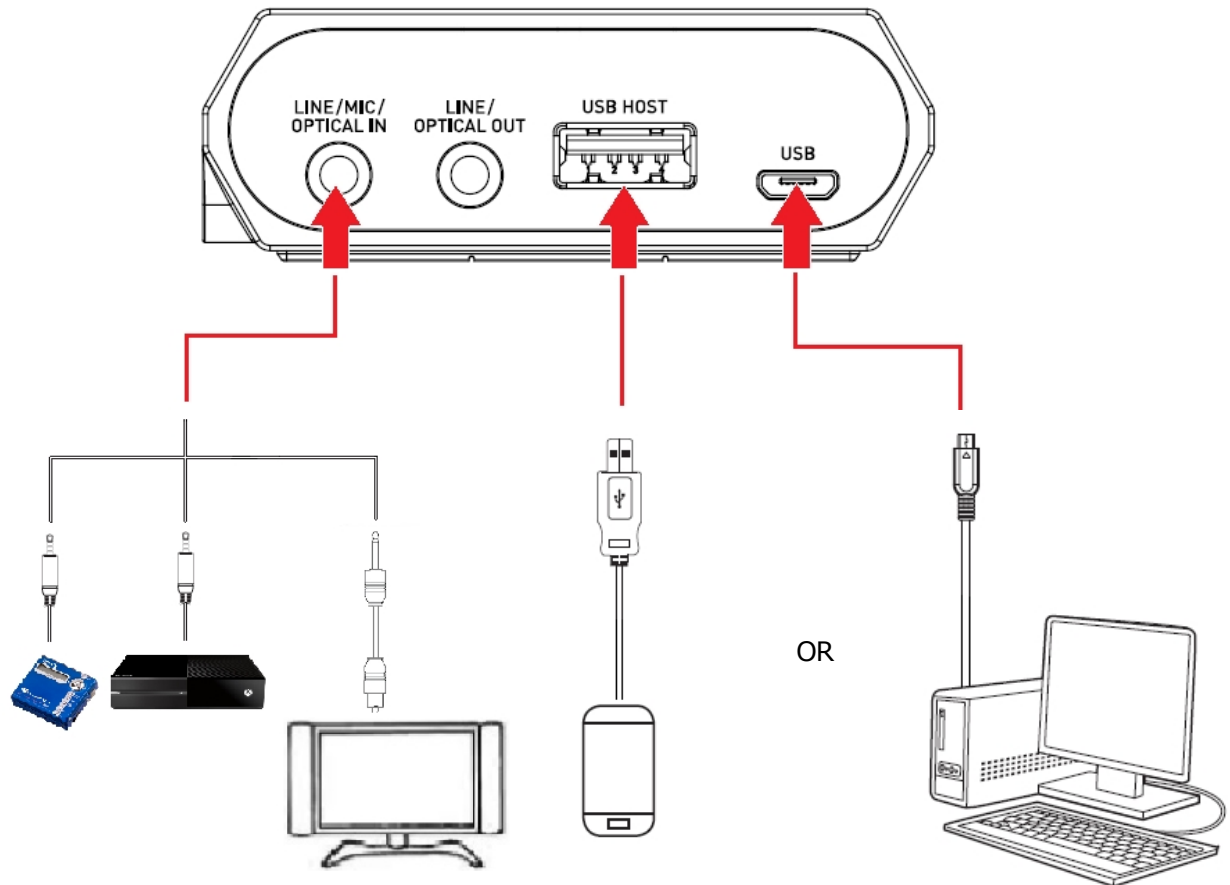

Note:

Signal levels can be adjusted using the Sound Blaster R5/E5 Control Panel or the Sound Blaster Central application. See **Using the Creative Software Suite**.

Recording "What U Hear"

(For Windows OS)

The Sound Blaster R5/E5 is equipped with **What U Hear** feature that allows you to record what is being played as it is.

You can also record voice conversations held over instant messaging tools such as Google Talk, Skype etc.

1. Go to **Control Panel** and click **Sound**.
2. Click the **Recording** tab, select **Sound Blaster R5/E5 (What U Hear)**, then click the **Set Default** button.
3. Play music on your connected device or activate your voice conversation.
4. Launch a third-party sound recording tool of your choice and start recording.

Using the Creative Software Suite

A software suite for the Sound Blaster R5/E5 is developed to provide additional enhancements to the audio and voice inputs and outputs of the product.

Applications

For Windows

- Sound Blaster R5/E5 Control Panel
- Creative ALchemy
- Creative Software Autoupdate
- Host OpenAL + EAX 5 HD
- Product Registration

For Mac

- Sound Blaster R5/E5 Control Panel
- Product Registration

For iOS and Android

- Sound Blaster Central

Bonus Pack Software (for Windows only)

Various other bonus Creative applications are also compatible for your audio device.

Visit www.creative.com/support and navigate to the relevant product page to view and download these applications:

- Creative WaveStudio
- Creative Smart Recorder

Supported Third-party Software

- Garage Band (for Mac only)

Sound Blaster R5/E5 Control Panel

The rest of this chapter explains how to use the Sound Blaster R5/E5 Control Panel to view and adjust the various features of your Sound Blaster R5/E5. The examples and screenshots below uses Windows as an example. The UI for other operating systems may differ slightly.

Managing Your Profiles

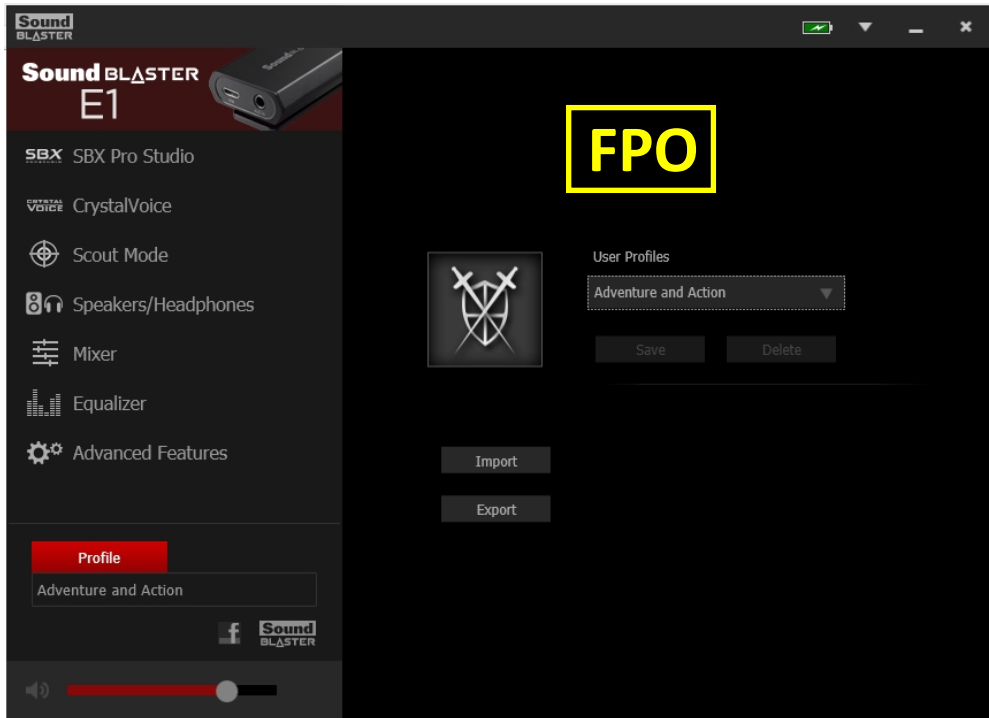

Click the **Profile** button to display the Profiles pane.

Activate a profile by clicking the  and selecting it from the list.

Click **Save** to save all settings to the current profile or create a new profile.

Click **Delete** to delete the active profile.

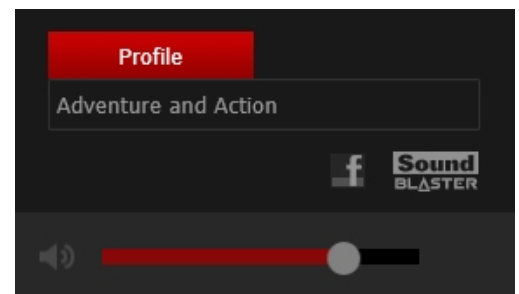

Sharing Profiles

You can export your custom settings and share them with others, or import other gamers' custom settings.

Customizing Your Avatar

You can customize the avatar for each profile by clicking the portrait and selecting another one from the list.

Adjusting Your Master Volume Settings

Drag the master volume slider to adjust the volume level. You can mute / unmute the volume by clicking the speaker icon.



Configuring Your General Settings

Click  from the top right corner of the interface and select the option from the list:

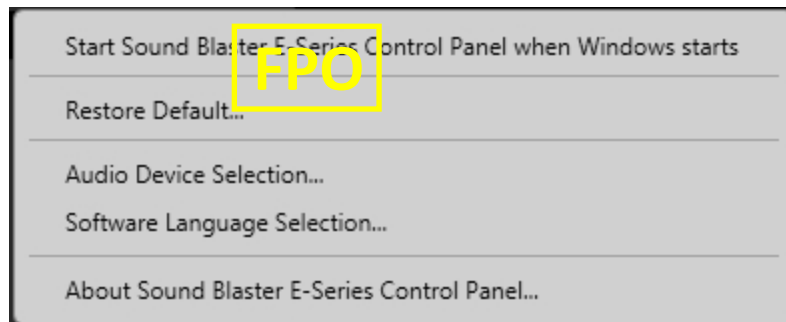

- Select whether the Sound Blaster R5/E5 Control Panel is activated when Windows starts. (*For Windows only*)
- Restore default settings.
- Select the audio playback device. (*For Windows only*)
- Select the supported software languages available for your system.
- General information regarding your Sound Blaster R5/E5 Control Panel software.

Battery

The battery icon  indicates the battery status of the Sound Blaster R5/E5.

SBX Pro Studio Settings



1. SBX Pro Studio enhancements
Select to turn on or turn off each enhancement.
You can hover your mouse cursor over each enhancement to display a brief explanation.
2. Enhancement Level sliders
Adjust the amount of enhancement to apply.
3. Audio test controls
Play/Pause or Stop the demo video.

Enhancing Your Listening Experience

You can adjust the amount to apply for each enhancement by dragging its slider left to decrease or right to increase. To test the effects of the audio enhancements, click  and listen to the demo video.

- **SBX Pro Studio Surround** provides immersion control of sounds not just around you, but also above and below for a full 3D audio experience. Hear the natural sense of audio depth, spaciousness and stunning 3D surround effects from your audio content. Enjoy an unbelievably true-to-life audio experience, whether it's over stereo speakers or headphones.
- **SBX Pro Studio Crystalizer** restores the dynamic range that is lost when iTunes and MP3 music gets compressed. This makes the music sound as good as the artist originally intended, and adds an enhanced level of realism for movies and games.
- **SBX Pro Studio Bass** fills in the low frequency tones and gives the extra impact for a better entertainment experience. It dramatically improves the sound experience without a subwoofer.
- **SBX Pro Studio Smart Volume** addresses the problem of abrupt volume level changes during playback and between songs by automatically and continuously measuring volume, and intelligently applying gain and attenuation to compensate for those changes.
- **SBX Pro Studio Dialog Plus** enhances the voices in movies for clearer dialog, allowing the listener to hear the dialog over the rest of the soundtrack and over ambient noise in the listening environment.

CrystalVoice Settings

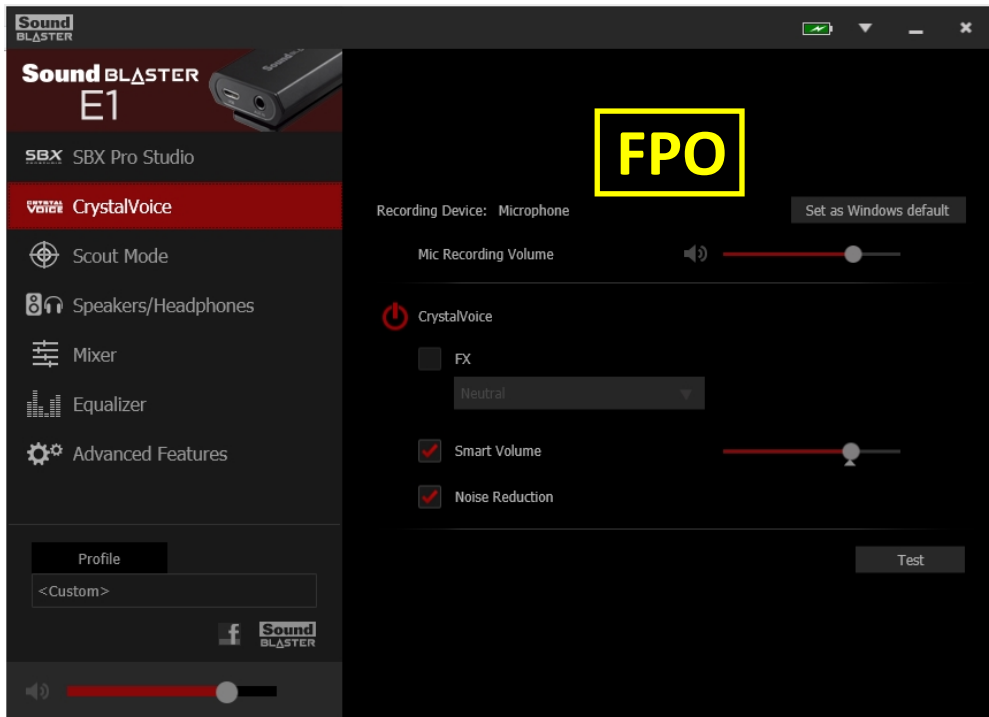

1. Volume sliders
Adjust the recording and monitoring volumes, or to mute/unmute them.
2. Microphone EQ
Select an equalizer preset suitable for your microphone.
3. Crystal Voice enhancements
Select to turn on or off each of the available enhancements.
4. Enhancement Level sliders
Adjust the amount of enhancement to apply.
5. Audio test button
Click **Test** and speak into your microphone to hear how your voice sounds with CrystalVoice applied.

Having Fun with CrystalVoice

You can adjust the amount to apply for each enhancement by dragging its slider left to decrease or right to increase. To test the effects of the audio enhancements, click **Test** and speak into your microphone.

- **CrystalVoice FX** enables the speaker's voice to be altered with a variety of effects, which can be used to enhance the tone of the speaker's voice, create interesting accents or to sound like a completely different person.
- **CrystalVoice Smart Volume** automatically adjusts the loudness of the speaker's voice to maintain a consistent volume level. This makes it convenient for the speaker to converse normally, regardless of whether the speaker is close to or far away from the microphone.
- **CrystalVoice Noise Reduction** enables the speaker to be heard clearly over background noise by constantly monitoring the environment and eliminate the unwanted noise that interferes with the conversation.

- **CrystalVoice Acoustic Echo Cancellation** eliminates echoes and enables the speaker to listen to the other party clearly. Echoes are a common problem present in voice communication systems that disrupts conversations by making it difficult to hear the other party.
- **CrystalVoice Focus** creates a zone and suppresses noise outside it to enable the speaker within to be heard with amazing clarity. Multiple microphones are used to focus, enhance the speaker's voice, and eliminate sounds outside the zone.

Speakers/Headphones Settings

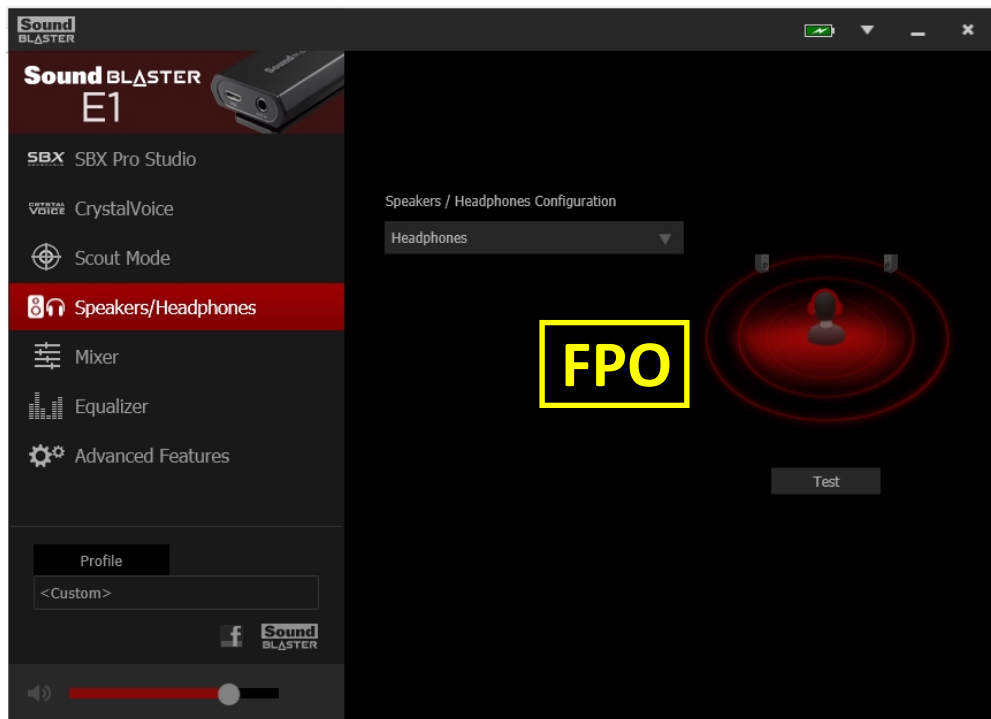

1. Speakers / Headphones Configuration
Shows your current physical speakers or headphones configuration.
2. Testing your audio playback
Click **Test** to hear a sample audio clip being played back through your setup.

Mixer Settings

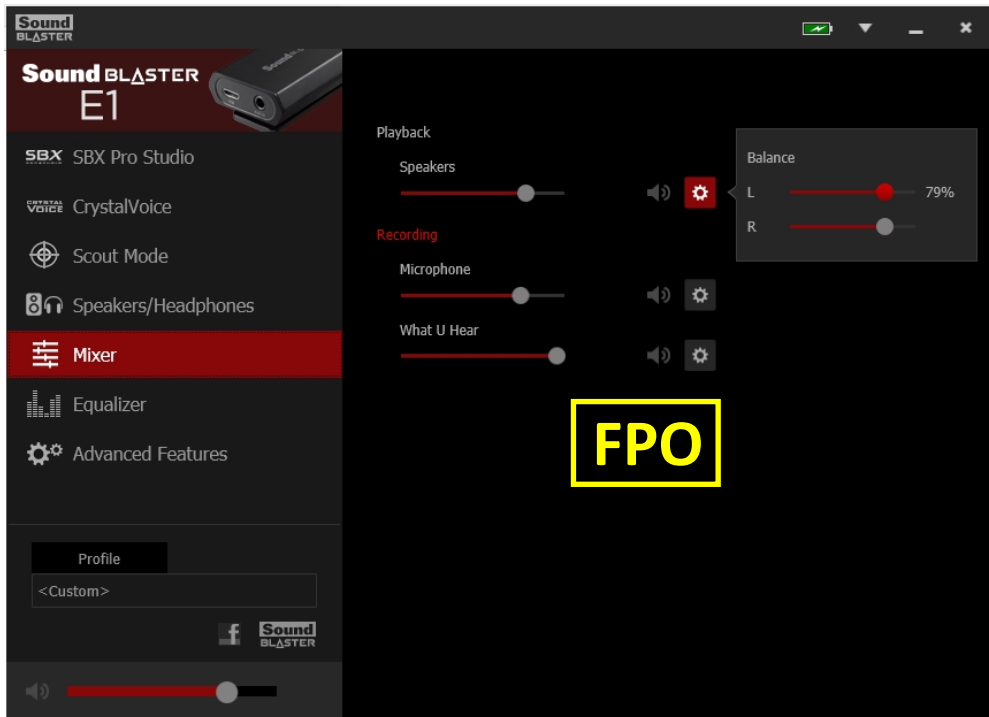

1. Volume sliders
Under **Playback**, adjust your playback and monitoring volumes, or to mute/unmute them.
Under **Recording**, adjust your recording volumes or to mute/unmute them.
2. You can click the  icon to adjust more settings for your input/output.

Equalizer Settings

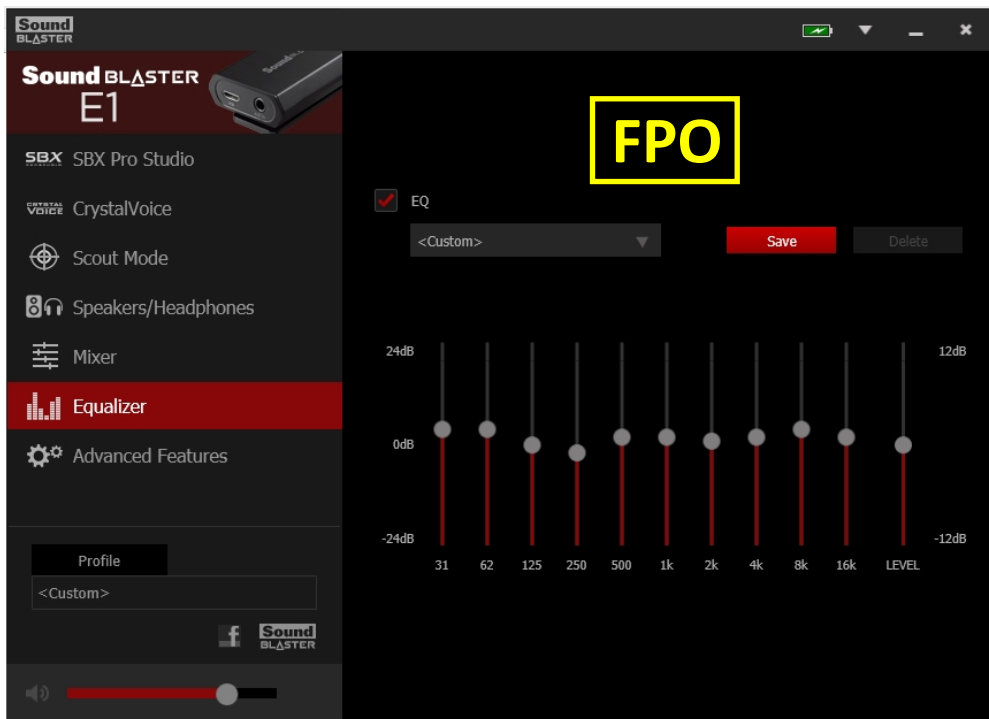

1. EQ presets
Select an equalizer preset to apply to your audio.
2. EQ sliders
Adjust the equalizer settings.

Customizing Your EQ Settings

Select the EQ checkbox to enable this feature, then click the EQ drop-down arrow and select a preset from the list.

Selecting a preset will move the EQ sliders to the appropriate values. You can then adjust the equalizer setting by dragging the sliders up or down to the desired level. Click **Save** to save the new configuration as a new preset.

Note:

The list of default EQ presets cannot be deleted or overwritten.

General Specifications

Inputs

- One 3.5 mm (1/8") line-in/mic-in/optical-in jack
- Built-in stereo microphones

Outputs

- Two 3.5 mm (1/8") headphones jack
- One 3.5 mm (1/8") line-out/optical-out jack

Connectivity

- One USB Type A host port
- One Micro-USB Type B port



Controls and Indicators

- Power / *Bluetooth* button and indicator
- SBX / Call button and indicator
- Gain switch for headphones gain setting
- Power/battery indicator
- Volume control knob

Physical Specifications

- Dimensions (L x W x H) : 35 x 19 x 66 mm
- Weight: Approx. 0.025 kg

Technical Specifications

- *Bluetooth* Version: *Bluetooth* v4.1
- Supported *Bluetooth* Profiles:
 - A2DP (Wireless Stereo *Bluetooth*)
 - AVRCP (*Bluetooth* Remote Control)
 - HFP (Hands-Free Profile)
- *Bluetooth* Operating Frequency: 2402 - 2480 MHz
- *Bluetooth* Operating Range: Up to 10 meters / 33 feet
(Measured in open space. Walls and structures may affect range of device.)
- Supported Audio Codec: AAC, SBC, aptX®
- Operating Temperature range: 0°C to 40°C (32°F to 104°F)
- Lithium Ion Battery: 3.7 V 3200 mAh (11.84 Wh)
- USB Input: 5V  500mA
- USB Output: 5V  500mA

- Headphone amplifier:
 - Normal: 33 ~ 300 ohms (1.5 ~ 3.3 V)
 - High: 300 ~ 600 ohms (3.3 ~ 6 V)

Troubleshooting and Support

This section provides solutions to problems you may encounter during installation or normal use. This includes:

- Problems with Sound
- Problems with Simultaneous Playback/Recording
- Tips to Improve Your Recording Quality
- Restore Default Settings

Problems with Sound

No sound from the headphones.

Check the following:

- The headphones are connected to the Headphone jack.
- Ensure the Sound Blaster R5/E5 is turned on.
- Ensure the volume control of the Sound Blaster R5/E5 is not at minimum level.
- Ensure the volume on your connected device or the media player is not muted.

No audio output when playing digital files such as WAV, MIDI files or AVI clips.

Check the following:

- The volume control is set at mid-range. Adjust the volume mixer settings in Sound Blaster R5/E5 Control Panel, if necessary.
- The powered speakers or external amplifier are connected to the Line Out jack.

No audio can be recorded from the built-in microphone.

Do the following:

- i. Navigate to Windows **Control Panel** > **Sound** > **Recording** tab.
- ii. Select **Sound Blaster R5/E5 (Internal Mic)** as the default recording device.
- iii. In the **Mixer** selection of Sound Blaster R5/E5 Control Panel, unmute the **Internal Mic** in the **Recording** section.

No audio can be recorded from the source connected to Line In/Mic In jack.

Do the following:

- i. Navigate to Windows **Control Panel** > **Sound** > **Recording** tab.
- ii. Select **Sound Blaster R5/E5 (Aux In or External Mic)** as the default recording device.
- iii. In the **Mixer** selection of Sound Blaster R5/E5 Control Panel, unmute the **Aux In or External Mic** in the **Recording** section.

Problems with Simultaneous Playback/Recording

An error message appears when recording and playing back simultaneously.

This may occur due to data transfer limitations if your computer is using a USB 1.1 connection. It may not be possible to play back, or simultaneously record and play back, content at the highest bit rate and/or frequency supported. Select lower bit depth and sampling rates for reduced CPU consumption and lower USB bandwidth requirements. Select lower settings if you encounter performance problems or if you run out of USB bandwidth. Lower sampling and bit depth rates, however, usually result in lower audio quality.

This should not be a problem if you are using a USB 2.0 connection.

Tips to Improve Your Recording Quality

The Sound Blaster R5/E5 Control Panel allows you to configure various audio settings to enhance your recording experience. You may toggle between the pre-configured microphone settings or adjust the audio configurations, such as microphone input volume, microphone equalizer, microphone boost, etc.

Restore Factory Default Settings

To reset your device to the factory default settings, press the **Power button** together with the **Volume Control knob** for 5 seconds and then release. All settings and configurations made previously on your device will be erased.

Additional Support

If you encounter any other issues or have any other enquiries about your Sound Blaster R5/E5 or any other Creative products, please visit our comprehensive knowledge base at support.creative.com or www.soundblaster.com for additional information.

Safety Information

Refer to the following information to use your product safely, and to reduce the chance of electric shock, short-circuiting, damage, fire, hearing impairment or other hazards. Improper handling may void the warranty for your product. For more information, read the warranty available with your product.

- Do not dismantle or attempt to repair your product.
Refer all servicing to authorized repair agents.
- Do not expose your product to temperatures outside the range of 0°C to 40°C (32°F to 104°F).
- Do not pierce, crush or set fire to your product.
- Keep your product away from strong magnetic objects.
- Do not subject your product to excessive force or impact.
- Do not expose your product to water or moisture.
If your product is moisture-resistant, take care not to immerse your product in water or expose it to rain.

Earphones

- Do not listen to audio on your earbuds or headphones at high volume for prolonged periods of time as hearing loss may result. For users in the United States, go to www.hei.org for more information.
- Do not listen to your audio device at high volume when driving, cycling or crossing the road, especially in heavy traffic or any other traffic condition where such use will hinder safe travel on the roads. We recommend that consumers be extremely cautious when using this device on the road.



Avoid Hearing Damage

Permanent hearing loss may occur if the headphone is used at high volume. Set the volume to a safe level. You can adapt over time to a higher volume of sound that may sound normal but can be damaging to your hearing. If you experience ringing in your ears or muffled speech, stop listening and have your hearing checked. The louder the volume, the less time is required before your hearing could be affected. Hearing experts suggest that to protect your hearing:

- Limit the amount of time you use the headphone at high volume.
- Avoid turning up the volume to block out noisy surroundings.
- Turn the volume down if you can't hear people speaking near you.

Embedded Battery

- Do not attempt to remove the embedded battery.
The product must be disposed of according to the local environmental regulations. To replace the battery, return your product to your regional support office. For product service information, go to www.creative.com.
- Do not expose to excessive heat such as sunlight, fire or the like.
- **CAUTION:** Risk of explosion if battery is replaced by incorrect types.

Wireless Product

- The short wave radio frequency signals of a wireless device may impair the operation of other electronic and medical devices.
- Switch off the device where it is prohibited. Do not use the device in medical facilities, aircraft, refueling points, close to automatic doors, automatic fire alarms or other automatically controlled devices.
- Keep this device at least 20 cm from pacemakers and other medical devices. Radio waves may impair the operation of pacemakers and other medical devices.

IMPORTANT — A LIRE AVEC ATTENTION

Ecouter de manière prolongée, à un très haut volume sonore de la musique (au dessus de 80 decibels), aumoyen d'un casque ou d'écouteurs, peut entraîner une détérioration irréversible et définitive de vos facultés auditives. L'usage répété et habituel d'un casque ou d'écouteurs à un niveau de volume sonore trop élevé peut donner l'impression à l'utilisateur que le volume sonore émis par l'appareil n'est pas suffisant. L'utilisateur sera tenté d'augmenter, petit à petit, son réglage habituel, risquant ainsi d'atteindre un niveau dangereux pour ses oreilles. Afin de protéger votre santé, et vos oreilles, veillez à maintenir le volume de la sortie casque de votre appareil à un niveau adapté et à interrompre son utilisation régulièrement et particulièrement si des symptômes, comme des troubles de l'ouïe, se manifestent.

N'utilisez pas le casque ou les écouteurs pendant la conduite d'une voiture, d'une bicyclette ou de tout autre véhicule motorisé, afin d'éviter tout accident de la circulation. En outre, il est interdit dans certains pays d'utiliser un casque ou des écouteurs en conduisant. Il peut être également dangereux d'écouter à volume élevé tout en marchant, spécialement aux passages piétons. Soyez toujours extrêmement prudent et cessez d'utiliser cet appareil dans les situations présentant des risques d'accident.

Evitez d'utiliser le casque ou les écouteurs à volume élevé. Les médecins spécialistes de l'audition déconseillent une écoute continue à volume trop élevé. Si vous percevez un sifflement dans les oreilles, réduisez le volume ou cessez l'écoute.

Maintenez un volume d'écoute modéré. Vous pourrez ainsi entendre les sons extérieurs et être attentif aux gens qui vous entourent.

Votre produit Creative accompagné des écouteurs fournis, est conforme à la réglementation française concernant les baladeurs musicaux (Arrêté du 24 Juillet 1998). Les caractéristiques techniques de ces écouteurs se trouvent dans le manuel en ligne et/ou sur le site internet de Creative. Si vous choisissez d'utiliser un autre casque ou d'autres écouteurs, veuillez vous assurer au préalable que leurs caractéristiques techniques soient les mêmes.

срок эксплуатационной долговечности

В соответствии с законодательством Российской Федерации компания Creative устанавливает для данного товара срок службы 2 года. Указанный срок – это период времени, в течение которого компания Creative гарантирует возможность использования продукции в соответствии с ее назначением. Кроме того, во время этого срока компания Creative гарантирует:

(i) безопасность товара, (ii) возможность выполнения его ремонта и получения технической поддержки, (iii) поставку запасных частей. Однако установление срока службы не означает автоматического бесплатного предоставления технической поддержки и обслуживания. Эти виды услуг предоставляются бесплатно только в течение гарантийного периода в соответствии с гарантийными обязательствами.

Regulatory Information

Notice for the USA

Federal Communication Commission (FCC) Interference Statement

FCC Part 15: This equipment has been tested and found to comply with the limits for a Class B digital device, pursuant to Part 15 of the FCC Rules. These limits are designed to provide reasonable protection against harmful interference in a residential installation. This equipment generates, uses and can radiate radio frequency energy and, if no installed and used in accordance with instructions, may cause harmful interference to radio communications. However, there is no guarantee that interference will not occur in a particular installation. If this equipment does cause harmful interference to radio or television reception, which can be determined by turning the equipment off and on, the user is encouraged to try to correct the interference by one or more of the following measures:

- Reorient or relocate the receiving antenna.
- Increase the separation between the equipment and receiver.
- Connect the equipment to an outlet on a circuit different from that to which the receiver is connected.
- Consult the dealer or an experienced radio/TV technician for help.

This device complies with part 15 of the FCC Rules. Operation is subjected to the following two conditions:

1. This device may not cause harmful interference, and
2. This device must accept any interference received, including interference that may cause undesired operation.

CAUTION: To comply with the limits of the Class B digital device, pursuant to Part 15 of the FCC Rules, this device must be installed with computer equipment certified to comply with Class B limits.

All cables used to connect to the computer and peripherals must be shielded and grounded. Operation with non-certified computers or non-shielded cables may result in interference to radio or television reception.

MODIFICATION: Any changes or modifications not expressly approved by the grantee of this device could void the user's authority to operate the device.

Federal Communication Commission (FCC) Radiation Exposure Statement

Power is so low that no RF exposure calculation is needed.

Notice for Canada

This Class B digital apparatus complies with Canadian ICES-003 and RSS-210.

Cet appareil numérique de classe B est conforme aux normes canadiennes NMB-003 et CNR-210.

This device complies with Industry Canada licence-exempt RSS standard.

Operation is subject to the following two conditions:

1. This device may not cause harmful interference, and
2. this device must accept any interference received, including interference that may cause undesirable operation.

Cet appareil est conforme avec Industrie Canada RSS standard exempts de licence.

Son fonctionnement est soumis aux deux conditions suivantes :

1. Le matériel ne peut être source D'interférences et
2. Doit accepter toutes les interférences reçues, Y compris celles pouvant provoquer un fonctionnement indésirable.

CANADIAN CLASS B STATEMENT: This digital device does not exceed the Class B limits for radio noise emissions from digital apparatus as set out in the interference-causing equipment statement entitled "Digital Apparatus", ICES-003 of the Department of Communications.

Cet appareil numérique respecte les limites de bruits radioélectriques applicables aux appareils numériques de Class B prescrites dans la norme sur le matériel brouilleur: "Appareils Numériques," NMB-003 édictée par le ministre des Communications.

MODIFICATION: Any changes or modifications not expressly approved by the grantee of this device could void the user's authority to operate the device.

Toute modification non approuvée explicitement par le fournisseur de licence de l'appareil peut entraîner l'annulation du droit de l'utilisateur à utiliser l'appareil.

DECLARATION OF CONFORMITY

According to the FCC96 208 and ET95-19

Manufacturer/Importer's Name: **Creative Labs, Inc.**

Manufacturer/Importer's Address: **1901 McCarthy Boulevard
Milpitas, CA. 95035
Tel: (408) 428-6600**

declares under its sole responsibility that the product

Trade Name: **Creative**

Model Number: **SB1590**

has been tested according to the FCC / CISPR22 requirement for Class B devices and found compliant with the following standards:

***EMI/EMC: ANSI C63.4, FCC Part 15 Subpart B& C
Complies with Canadian ICES-003 Class B and RSS-210 standards***

This device complies with part 15 of the FCC Rules.

Operation is subject to the following two conditions:

- (1) This device may not cause harmful interference, and*
- (2) this device must accept any interference received, including Interference that may cause undesirable operation.*

Ce matériel est conforme à la section 15 des règles FCC.

Son Fonctionnement est soumis aux deux conditions suivantes :

- (1) Le matériel ne peut être source D'interférences et*
- (2) Doit accepter toutes les interférences reçues, Y compris celles pouvant provoquer un fonctionnement indésirable.*

Supplementary Information:

Compliance Manager
Creative Labs, Inc.
<DATE>

European Compliance

This product conforms to the following:



EMC Directive 2004/108/EC.

RoHS Directive 2011/65/EU.

Mains operated products for the European market comply with Low Voltage Directive 2006/95/EC and Commission Regulation(s) Implementing Directive 2009/125/EC.

Communication/RF wireless products for the European market comply with R&TTE Directive 1999/5/EC.

CAUTION: To comply with the Europe CE requirement, this device must be installed with CE certified computer equipment which meet with Class B limits.

All cables used to connect this device must be shielded, grounded and no longer than 3m in length. Operation with non-certified computers or incorrect cables may result in interference to other devices or undesired effects to the product.

MODIFICATION: Any changes or modifications not expressly approved by Creative Technology Limited or one of its affiliated companies could void the user's warranty and guarantee rights.

Conformité européenne

Ce produit est conforme aux normes suivantes :

Directive 2004/108/CE sur les émissions électromagnétiques.

Directive RoHS 2011/65/UE.

Les produits secteur pour le marché européen sont conformes à la Directive sur la faible tension 2006/95/CE et à la réglementation de la Commission exécutant la Directive 2009/125/CE.

Les produits de communication/sans fil RF destinés au marché européen sont conformes à la directive R&TTE 1999/5/CE.

ATTENTION : pour respecter les critères CE d'Europe, cet appareil doit être installé avec du matériel informatique certifié CE respectant les limites de la classe B.

Tous les câbles utilisés pour connecter cet appareil doivent être blindés, reliés à la terre et ne pas faire plus de 3 m de long. L'utilisation d'ordinateurs non certifiés ou de câbles inappropriés peut entraîner des interférences avec d'autres appareils ou des effets indésirables sur le produit.

MODIFICATION : toute modification non approuvée explicitement par Creative Technology Limited ou l'une de ses sociétés affiliées peut entraîner l'annulation de la garantie et des droits de garantie de l'utilisateur.

Conformità alle normative europee

Questo prodotto è conforme alla seguente normativa:

Direttiva EMC 2004/108/CE.

Direttiva RoHS 2011/65/UE.

I prodotti che funzionano con corrente di rete per il mercato europeo sono conformi alla direttiva bassa tensione 2006/95/CE e alla direttiva di implementazione nelle normative europee 2009/125/CE.

I prodotti di comunicazione/wireless RF per il mercato europeo sono conformi alla Direttiva R&TTE 1999/5/CE.

ATTENZIONE: ai fini della conformità con i requisiti del marchio CE europeo, il dispositivo deve essere installato in un computer certificato CE conforme ai limiti di Classe B.

Tutti i cavi usati per collegare il dispositivo devono essere schermati, dotati di idonea messa a terra e avere una lunghezza massima di 3 metri. L'uso del dispositivo con computer non certificati o cavi non idonei può provocare interferenze ad altri dispositivi nonché danneggiare il prodotto stesso.

MODIFICHE: eventuali modifiche o alterazioni non espressamente approvate da Creative Technology Limited o dalle sue società controllate possono rendere nulli la garanzia e il diritto dell'utente a utilizzare il prodotto.

Einhaltung der europäischen Bestimmungen

Dieses Produkt erfüllt die folgenden Bestimmungen:

EMC-Richtlinie 2004/108/EG.

RoHS-richtlinie 2011/65/EU.

Netzbetriebene Produkte für den europäischen Markt erfüllen die Niederspannungsverordnung 2006/95/EG und der Commission Regulation(s) Implementing-Verordnung 2009/125/EG.

Drahtlose Kommunikationsgeräte/Funksender und -empfänger für den europäischen Markt erfüllen die R&TTE-Richtlinie 1999/5/EG.

ACHTUNG: Um die Anforderungen der europäischen CE-Norm zu erfüllen, muss dieses Produkt an einem CE-geprüften Computer der Klasse B angeschlossen werden.

Alle Verbindungskabel zu diesem Gerät müssen abgeschirmt und geerdet sein und dürfen nicht länger als 3 m sein. Der Betrieb mit nicht zertifizierten Computern oder nicht ordnungsgemäßen Kabeln kann zu Störungen anderer Geräte oder unerwünschten Auswirkungen auf das Produkt führen.

MODIFIZIERUNG: Jegliche Änderung oder Modifizierung des Produkts, die nicht ausdrücklich von Creative Technology Limited oder einer der zugehörigen Firmen genehmigt worden ist, kann für den Benutzer zum Erlöschen der Garantie und der Gewährleistungsrechte führen.

Homologación para Europa

Este producto cumple:

la Directiva de compatibilidad electromagnética 2004/108/CE.

Directiva RoHS 2011/65/UE.

Los productos funcionando con corriente eléctrica cumplen con la Directiva 2006/95/CE de baja tensión y con la implementación de los requisitos de la Comisión para la directiva 2009/125/CE.

Los productos inalámbricos de comunicación o frecuencias de radio para el mercado europeo cumplen la Directiva 1999/5/CE de equipos de radio y terminales de telecomunicaciones.

ATENCIÓN: para cumplir con los requisitos de Homologación para Europa, este dispositivo debe instalarse con un equipo informático con certificación CE que cumpla los límites de la Clase B. Todos los cables utilizados para conectar este dispositivo deben estar protegidos, conectados a tierra y no tener más de 3 m de longitud. El funcionamiento del dispositivo con equipos no certificados o cables incorrectos podría provocar interferencias a otros dispositivos o efectos no deseados al producto.

MODIFICACIÓN: los cambios o modificaciones no aprobados expresamente por Creative Technology Limited o una de sus empresas afiliadas podrían invalidar la garantía del usuario y los derechos de la garantía.

Europese naleving

Dit product voldoet aan de volgende voorschriften:

EMC-richtlijn 2004/108/EG.

RoHS-richtlijn 2011/65/EU.

Electrische producten voor de Europese markt voldoen aan de Laagspanningsrichtlijn 2006/95/EG en EC and Verordening(en) voor uitvoering van Richtlijn 2009/125/EG.

Communicatie- of draadloze RF-producten voor de Europese markt voldoen aan de richtlijn R&TTE 1999/5/EG.

LET OP: Om te voldoen aan de Europese CE-norm, moet dit apparaat zijn geïnstalleerd in computerapparatuur die CE-gecertificeerd is voor de Klasse B-limieten.

Alle kabels die worden gebruikt om dit apparaat aan te sluiten, moeten zijn afgeschermd en geaard, en mogen niet langer dan 3 meter zijn. Gebruik met niet-gecertificeerde computers of incorrecte kabels kan leiden tot interferentie van andere apparaten of ongewenste effecten op het product.

AANPASSING: Alle wijzigingen of modificaties die niet uitdrukkelijk zijn goedgekeurd door Creative Technology Limited of een van de gelieerde maatschappijen, kunnen ertoe leiden dat de rechten van de gebruiker met betrekking tot garantie en vrijwaring vervallen.

Conformidade Europeia

Este produto está em conformidade com a seguinte regulamentação:

Directiva EMC 2004/108/EC.

Directiva RoHS 2011/65/UE.

Os produtos com ligação à rede destinados ao mercado europeu estão em conformidade com a directiva de baixa voltagem 2006/95/CE. Directiva de Implementação do(s) Regulamento(s) da Comissão 2009/125/CE.

Os produtos de comunicação/radiofrequência sem fios destinados ao mercado europeu estão em conformidade com a directiva R&TTE 1999/5/CE.

ATENÇÃO: De modo a cumprir com os requisitos da marca CE Europeia, este dispositivo deve ser instalado com equipamento informático com certificação CE que cumpra com os limites de Classe B limits.

Todos os cabos usados para ligar este dispositivo devem ser blindados, ligados à terra e não devem exceder os 3m de comprimento. O funcionamento com computadores não certificados ou cabos incorrectos pode resultar em interferências em outros dispositivos ou provocar efeitos indesejados no produto.

MODIFICAÇÃO: Quaisquer alterações ou modificações que não sejam expressamente aprovadas pela Creative Technology Limited ou por uma das suas afiliadas, pode anular a garantia do utilizador e os direitos inerentes à mesma.

Europeisk efterlevnad

Denna produkt uppfyller följande:

EMC-direktivet 2004/108/EC.

RoHS Direktivet 2011/65/EU.

Produkter för den europeiska marknaden som drivs via elnätet uppfyller Lågspänningsdirektivet 2006/95/EC och Kommissionens regleringsimplementeringsdirektiv 2009/125/EG.

Trådlösa kommunikations/RF-produkter för den europeiska marknaden uppfyller R&TTE-direktivet 1999/5/EC.

WARNING: För att uppfylla CE-kraven i Europa måste denna produkt installeras med CE-certifierad datorutrustning som uppfyller gränsvärdena för klass B.

Alla kablar som används för anslutning av denna produkt måste vara avskärmade, jordade och får inte vara längre än 3 m. Användning med icke certifierade datorer eller felaktiga kablar kan leda till interferens på annan utrustning eller oönskade effekter på produkten.

MODIFIERING: Alla förändringar och modifieringar som inte är uttryckligen tillåtna av Creative Technology limited eller något av dess filialföretag kan göra användarens garanti och garantirättigheter ogiltiga.

Europeisk samsvar

Dette produktet er i samsvar med følgende:

EMC-direktivet 2004/108/EC.

RoHS-Direktivet 2011/65/EU.

Elektriske produkter til det europeiske markedet er i samsvar med Lavspenningsdirektivet 2006/95/EC og Økodesigndirektivet 2009/125/EC.

Kommunikasjon/RF trådløse produkter til det europeiske markedet er i samsvar med R&TTE-direktivet 1999/5/EC.

ADVARSEL: For å overholde det europeiske CE-kravet må denne enheten installeres med CE-sertifisert datautstyr som tilfredsstillende klasse B-grensene.

Alle kabler som kobles til enheten må være skjermet, jordet og ikke lenger enn 3 m i lengde. Bruk av ikke-sertifiserte datamaskiner eller feil kabler kan føre til forstyrrelse av andre enheter eller uønsket effekt på produktet.

MODIFIKASJON: Eventuelle endringer eller modifikasjoner som ikke uttrykkelig er godkjent av Creative Technology Limited eller et av dets tilknyttede selskaper, kan ugyldiggjøre garantien eller garantirettighetene.

Overholdelse af Europæiske regler og standarder

Dette produkt overholder følgende:

EMC-direktivet 2004/108/EC.

RoHS-Direktivet 2011/65/EU.

Produkter til det Europæiske marked, skal overholde Lavspændingsdirektivet 2006/95/EC og Kommissionens forordninger for implementering af direktivet 2009/125/EF.

Kommunikations- / RF-trådløse produkter til det Europæiske overholder R&TTE-direktivet 1999/5/EC.

ADVARSEL: For at overholde Europe CE-kravet, skal denne enheden installeres med CE-certificeret computerudstyr, der opfylder klasse B-grænserne.

Alle kabler der anvendes til at tilslutte enheden skal være skærmede, jordforbundne og ikke længere end 3 m lange. Drift med ikke-certificerede computere og ukorrekte kabler kan medføre interferens for andre enheder eller uønskede effekter på produktet.

MODIFIKATION: Enhver ændring eller modifikation, der ikke er udtrykkeligt godkendt af Creative Technology Limited eller et associerede selskab, vil gøre brugerens garanti og garanterede rettigheder ugyldig.

Eurooppalainen yhdenmukaisuus

Tämä tuote täyttää seuraavat tuotemääritykset:

TEMC-direktiivin 2004/108/EC.

RoHS-direktiivin 2011/65/EU.

Euroopan markkinoiden verkkovirtaa käyttävät tuotteet ovat matalajännitedirektiivin 2006/95/EY mukaisia. Euroopan parlamentin ja neuvoston ohjaava direktiivi 2009/125/EY.

Euroopan markkinoiden tietoliikenne- ja langattomat radiotaajuustuotteet noudattavat R&TTE-direktiiviä 1999/5/EY.

VAROITUS: Jotta tämä laite noudattaisi Euroopan CE-vaatimuksia, tämä laite on asennettava CE-sertifioituun tietokoneeseen, joka noudattaa luokan B rajoituksia.

Kaikki tämän laitteen liittämiseen käytetyt kaapelit tulee suojata ja maadoittaa eivätkä ne saa olla 3 m pidempiä. Luokan rajoituksia noudattamattoman tietokoneen tai vääränlaisten kaapeleiden käyttäminen voi aiheuttaa häiriöitä muihin laitteisiin tai haitata itse laitteen toimintaa.

MUOKKAUKSET: Muutokset tai muokkaukset, joita Creative Technology Limited tai sen tytäryhtiöt eivät nimenomaisesti ole hyväksyneet, voivat mitätöidä tuotteelle annetun takuun.

Evropská shoda

Tento výrobek splňuje následující směrnice:

Směrnice EMC 2004/108/EC.

Směrnice RoHS 2011/65/EU.

Výrobky napájené z elektrické zásuvky pro evropský trh splňují směrnici o nízkém napětí 2006/95/EC a směrnici komise 2009/125/EC o zavádění předpisů.

Komunikační / vysokofrekvenční bezdrátové výrobky pro evropský trh splňují směrnici R&TTE 1999/5/EC.

UPOZORNĚNÍ: Aby toto zařízení splňovalo evropský požadavek CE, musí být nainstalováno s počítačovým vybavením s certifikátem CE, které splňuje limity pro zařízení třídy B.

Veškeré kabely používané pro připojení tohoto zařízení musí být stíněné, uzemněné a nesmí být delší než 3 metry. Při používání s necertifikovanými počítači nebo nesprávnými kabely může dojít k rušení jiných zařízení nebo k nežádoucím vlivům na produkt.

ÚPRAVY: Jakékoli změny nebo úpravy, které nebyly vysloveně schváleny společností Creative Technology Limited nebo některou z jejích dceřiných společností, mohou způsobit propadnutí záruky uživatele a záručních práv.

Zgodność z przepisami europejskimi

Urządzenie jest zgodne z

dyrektywą EMC 2004/108/EC.

Dyrektywa RoHS 2011/65/UE.

Urządzenia zasilane z sieci elektrycznej przeznaczone na rynek europejski muszą być zgodne z dyrektywą dotyczącą urządzeń niskonapięciowych 2006/95/EC oraz z dyrektywą wdrażającą komisji regulacyjnej 2009/125/WE.

Urządzenia komunikacyjne / bezprzewodowe wykorzystujące transmisję radiową przeznaczone na rynek europejski spełniają warunki dyrektywy RTTE 1999/5/EC.

UWAGA: Aby uzyskać zgodność z wymogami europejskiej normy CE urządzenie musi być zainstalowane wraz ze sprzętem komputerowym mającym certyfikat CE z ograniczeniami klasy B.

Wszystkie przewody używane do podłączania niniejszego urządzenia muszą być ekranowane, uziemione i nie dłuższe niż 3 metry. Użytkowanie z komputerami nie posiadającymi certyfikatów lub wykorzystanie niewłaściwych przewodów może powodować zakłócenia pracy innych urządzeń lub opisywanego urządzenia.

MODYFIKACJE: Dokonanie jakichkolwiek zmian lub modyfikacji, na które firma Creative Technology Limited lub spółki z nią stowarzyszone nie udzielają wyraźnej zgody, może doprowadzić do unieważnienia praw gwarancji i rękojmi użytkownika.

Соответствие европейским нормам

Данное изделие соответствует следующим стандартам:

EMC Директива 2004/108/EC.

Продукция с питанием от сети, поставляемая на европейский рынок, соответствует Директиве по низковольтному оборудованию 2006/95/EC и Имплементирующей директиве постановления (-й) комиссии 2009/125/EC.

Коммуникационное/радио- беспроводное оборудование, поставляемое на европейский рынок, соответствует Директиве по окончному радио- и телекоммуникационному оборудованию 1999/5/EC.

ВНИМАНИЕ! Для обеспечения соответствия европейским требованиям CE, это устройство должно устанавливаться с компьютерным оборудованием, сертифицированным по стандарту CE и удовлетворяющим нормам класса B.

Все кабели, используемые для подключения данного устройства, должны быть экранированы, заземлены и иметь длину не более 3 м. Работа с несертифицированными компьютерами или неподходящими кабелями может привести к возникновению помех другим устройствам или негативному влиянию на работу самого изделия.

ИЗМЕНЕНИЯ КОНСТРУКЦИИ Любые изменения конструкции, на которые не было получено прямое разрешение компании Creative Technology Limited или ее дочерней компании, может привести к аннуляции гарантии и связанных с ней прав.

Ευρωπαϊκή συμμόρφωση

Εξαιτίας της συμμόρφωσης με τα παρακάτω:

2004/108/ΕΚ, az elektromágneses összeférhetőségre. 2011/65/EU, RoHS.

Αυτά τα προϊόντα συμμορφώνονται με τα παρακάτω: 2006/95/ΕΚ, az elektromágneses összeférhetőségre. 2011/65/EU, RoHS.

Αυτά τα προϊόντα συμμορφώνονται με τα παρακάτω: 2006/95/ΕΚ, az elektromágneses összeférhetőségre. 2011/65/EU, RoHS.

Αυτά τα προϊόντα συμμορφώνονται με τα παρακάτω: 2006/95/ΕΚ, az elektromágneses összeférhetőségre. 2011/65/EU, RoHS.

FIGYELEM! Az európai CE követelmények teljesítéséhez ezt a készüléket a B kategóriájú értékeknek megfelelő, CE minősítésű számítógéppel együtt kell telepíteni.

A készülék csatlakoztatására használt valamennyi kábelnek árnyékoltnak és földeltnek kell lennie, továbbá hosszúsága nem haladhatja meg a 3 métert. A nem hitelesített számítógépekkel vagy helytelen kábelekkel való használat más készülékek zavarását vagy a termék nem kívánatos befolyását okozhatja.

ΜΟΔΟΣΙΤΑΣ: Minden módosítás vagy változtatás, amit kifejezetten nem hagyott jóvá a Creative Technology Limited vagy valamelyik leányvállalata, érvénytelenítheti a készülék garanciáját és felhasználó garanciális jogait.

Ευρωπαϊκή συμμόρφωση

Το παρόν προϊόν συμμορφώνεται με τα παρακάτω:

Οδηγία ΗΜΣ 2004/108/ΕΚ.

Οδηγία RoHS 2011/65/ΕΕ.

Τα προϊόντα που λειτουργούν με ρεύμα για την ευρωπαϊκή αγορά συμμορφώνονται με την Οδηγία περί χαμηλής τάσης 2006/95/ΕΚ και τους κανονισμούς της επιτροπής που υλοποιούν την οδηγία 2009/125/ΕΚ.

Τα ασύρματα προϊόντα επικοινωνιών / RF για την ευρωπαϊκή αγορά συμμορφώνονται με την οδηγία R&TTE 1999/5/ΕΚ.

ΠΡΟΣΟΧΗ: Για τη συμμόρφωση με τις απαιτήσεις του ευρωπαϊκού CE, αυτή η συσκευή θα πρέπει να εγκατασταθεί σε εξοπλισμό υπολογιστή με πιστοποίηση CE ο οποίος πληροί τα όρια της κατηγορίας Β.

Όλα τα καλώδια που χρησιμοποιούνται για τη σύνδεση της συσκευής θα πρέπει να είναι θωρακισμένα, γειωμένα και να μην υπερβαίνουν σε μήκος τα 3μ. Η λειτουργία με μη πιστοποιημένους υπολογιστές ή λάθος καλώδια μπορεί να οδηγήσει σε παρεμβολές με άλλες συσκευές ή ανεπιθύμητες επιδράσεις στο προϊόν.

ΤΡΟΠΟΠΟΙΗΣΗ: Οι όποιες αλλαγές ή τροποποιήσεις που δεν έχουν εγκριθεί ρητά από την Creative Technology Limited ή κάποια από τις θυγατρικές της ενδέχεται να ακυρώσουν την εγγύηση του χρήστη και τα δικαιώματα που απορρέουν από αυτήν.

Europos Sąjungos atitiktis

Šis gaminys atitinka šiuos reikalavimus:

„Elektromagnetinės atitikties“ („EMC“) direktyva 2004/108/EC.

RoHS direktyva 2011/65/ES.

Produktai, kurie veikia maitinami iš elektros tinklo, skirti Europos rinkai, atitinka Žemos įtampos direktyvą 2006/95/EB.

Komisijos reglamentas(-ai) dėl Direktyvos 2009/125/EB įgyvendinimo.

Europos Sąjungos rinkai skirti ryšių / radijo dažnių bevieliai gaminiai atitinka 1999/5/EB direktyvą „Dėl radijo ryšio įrenginių ir telekomunikacijų galinių įrenginių bei abipusio jų atitikties pripažinimo“.

ATSARGIAI: Tam, kad šis prietaisas atitiktų Europos Sąjungos „CE“ reikalavimus, jis turi būti įdiegtas į „CE“ sertifikuotą kompiuterinę įrangą, atitinkančią „B“ klasės ribas. Visi su šiuo prietaisu naudojami laidai turi būti ekranuoti, išeminti ir nevirstyti 3 m ilgio. Nesertifikuotų kompiuterių ar netinkamų laidų naudojimas gali tapti trikdžių kitiems prietaisams arba nepageidaujamų šio gaminio veikimo pasekmių priežastimi.

MODIFIKAVIMAS: Bet kokie pakeitimai ar modifikavimai neturint aiškiai patvirtinto „Creative Technology Limited“ ar vienos iš su ja susijusių bendrovių leidimo gali panaikinti vartotojo garantiją ir garantijos teises.

Dođržiavanie predpisov Európskej únie

Tento výrobok splna nasledujúce normy:

Smernica EMC 2004/108/ES.

Smernica RoHS 2011/65/EÚ.

Výrobky napájané zo siete určené na európsky trh sú v súlade so smernicou o harmonizácii právnych predpisov členských štátov týkajúcich sa elektrického zariadenia určeného na používanie v rámci určitých limitov napätia 2006/95/ES a s nariadeniami Komisie, ktorými sa vykonáva smernica 2009/125/ES.

Bezdrôtové komunikacné/RF výrobky určené na európsky trh sú v súlade so smernicou R&TTE 1999/5/ES.

VAROVANIE: Toto zariadenie musí byť nainštalované s počítačovým zariadením s certifikáciou CE, ktoré splna limity triedy B, aby bolo v súlade s európskymi požiadavkami CE.

Všetky káble použité na pripojenie tohto zariadenia musia byť tienené, uzemnené a nie dlhšie ako 3 m. Prevádzka pomocou necertifikovaných počítačov alebo nesprávnych káblov môže mať za následok rušenie iných zariadení alebo nežiaduce účinky na výrobok.

ÚPRAVY: Akékoľvek zmeny alebo úpravy, ktoré neboli výslovne odsúhlasené spoločnosťou Creative Technology Limited alebo jednou z jej sesterských spoločností, môžu zrušiť platnosť záruky a záručných práv používateľa.

Avrupa Uyumu

Bu ürün ařađıdakilere uygundur:

2004/108/EC EMC (Elektromanyetik Uyumluluk) Yönetmeliđi.

2011/65/EC RoHS (Tehlikeli Maddelerin Kısıtlanması) Yönetmeliđi

Avrupa piyasasına yönelik, elektrik řebekesi tarafından alıřtırılan ürünler 2006/95/EC Alak Gerilim Yönetmeliđi (LVD) ve 2009/125/EC Enerji ile İlgili Ürünlerin evreye Duyarlı Tasarımına İliřkin Yönetmeliđe uygundur.

Avrupa piyasasına yönelik İletişim / RF kablosuz ürünleri R ve TTE Yönetmeliđi 1999/5/EC ile uyumludur.

DİKKAT: Avrupa CE gereksinimleriyle uyumlu olması için bu cihazın, B Sınıfı sınırlarına uygun olan CE sertifikalı bilgisayar donanımları ile birlikte kurulması gerekir.

Bu cihazı bađlamak için kullanılan tüm kabloların koruyuculu ve topraklanmış olması ve 3 metreden uzun olmaması gerekir. Sertifikalı olmayan bilgisayarlarla veya yanlış kablolarla birlikte kullanılması, diđer cihazların düzgün alıřmamasına veya üründe istenmeyen etkiler görülmesine neden olabilir.

DEĐİŐİKLİKLER: Creative Technology Limited veya bađlı řirketlerinden biri tarafından açıka onaylanmamıř tüm deđiřiklikler kullanıcının garanti ve teminat haklarını geçersiz kılabilir.

Ukraine RoHS Statement

Обладнання відповідає вимогам Технічного регламенту щодо обмеження використання деяких небезпечних речовин в електричному та електронному обладнанні, затвердженого постановою Кабінету Міністрів України від 3 грудня 2008 № 1057

Notice for Japan

充電式電池のリサイクル



Li-ion

充電式リチウム電池はリサイクル可能な資源です。

- Creative製品に埋め込まれている充電式リチウム電池をリサイクルするために、本体から電池を取り外さないでください。リサイクルに関する情報および指示については、Creative Media K Kカスタマーサポート <http://jp.creative.com/support/contact/> (日本語) をご覧ください。
- 交換可能な (取り外し可能な) 充電式リチウム電池のリサイクルについては、以下をご覧ください。



注意事項

- 充電式リチウム電池が完全に放電した場合、取り外すことを推奨します。
- 電池の金属部分にはセロハンテープなどの絶縁物質で覆うなど、注意が必要です。
- 充電式電池のリサイクルおよび回収、および対応店舗に関する情報は、JBRCのホームページをご覧ください。 (<http://www.jbrc.com/>)

Notice for Korea

B급 기기

(가정용 방송통신기자재)

Class B Equipment

(For Home Use Broadcasting & Communication Equipment)

이 기기는 가정용 (B급) 전자파적합기기로서 주로 가정에서 사용하는 것을 목적으로 하며, 모든 지역에서 사용할 수 있습니다.

This equipment is home use (Class B) electromagnetic wave suitability equipment and to be used mainly at home an it can be used in all areas.

Notice for China



此图示为“电子信息产品污染控制标志”，是企业用于声明其产品符合《电子信息产品污染控制管理办法》有关标识要求的唯一有效标志。图示中间的数字明示电子信息产品的环保使用期限（单位为年，起始日期为产品的生产日期）；图形外圈由带有箭头的线条组成一个循环起来的圆，表示该电子信息产品可回收利用。此图示含义为：该电子信息产品可能含有某些有毒有害物质（如下表所示），在环保使用期限内可以放心使用，超过环保使用期限之后则应该进入回收循环系统。

部件名称*	有毒有害物质或元素					
	铅 (Pb)	汞 (Hg)	镉 (Cd)	六价铬 (Cr ⁶⁺)	多溴联苯 (PBB)	多溴二苯醚 (PBDE)
显示面板	X	X	○	○	○	○
电源线/适配器	X	○	○	○	○	○
电池	X	○	○	○	○	○
遥控器 (含电池)	X	○	○	○	○	○
电路板组件	X	○	○	○	○	○

“○”：表示该有毒有害物质在该部件所有均质材料中的含量均在SJ/T 11363-2006标准规定的限量要求以下。
 “X”：表示该有毒有害物质至少在该部件的某一均质材料中的含量超出SJ/T 11363-2006标准规定的限量要求，其原因为目前业界还没有可替代的技术。
 *：各个型号的产品规格及所含部件可能有所不同，应将产品中的任何可充电电池组脱离系统单独考虑，因为电池组的“环保使用期限”可能比整个系统的要短，一般为5年。

Vietnam RoHS Statement

This product is in compliance with Circular 30/2011/TTBCT of the Ministry of Trade of the Socialist Republic of Vietnam (“Circular”), it does not contain the following substances in concentration greater than the Maximum Limit value as specified in the Circular.

Substance	Maximum Limit (ppm) ^{1, 2}
• lead	1000
• mercury	1000
• cadmium	100
• hexavalent chromium	1000
• polybrominated biphenyls (PBB)	1000
• polybrominated diphenyl ethers (PBDE)	1000

¹ Maximum Limit does not apply to applications exempted from the Circular.

² Maximum Limit refers to concentration by weight in homogeneous materials.

Notice for Singapore

Complies with
IDA Standard
DB00148

License and Copyright

Information in this document is subject to change without notice and does not represent a commitment on the part of Creative Technology Ltd. No part of this manual may be reproduced or transmitted in any form or by any means, electronic or mechanical, including photocopying and recording, for any purpose without the written permission of Creative Technology Ltd.

© 2014 Creative Technology Ltd. All rights reserved. Creative, the Creative logo, Sound Blaster, the Sound Blaster logo, SBX Pro Studio, the SBX logo and CrystalVoice are trademarks or registered trademarks of Creative Technology Ltd. in the United States and/or other countries. The *Bluetooth*[®] word mark and logos are owned by Bluetooth SIG, Inc. and any use of such marks by Creative Technology Ltd is under license. Intel and Intel Core are trademarks of Intel Corporation in the U.S. and/or other countries. AMD is a registered trademark of Advanced Micro Devices, Inc. Microsoft, Windows and Windows Vista are registered trademarks of Microsoft Corporation. iPhone, iPad, Mac, Mac OS, OS X and GarageBand are registered trademarks of Apple Inc. Android is a trademark of Google Inc. aptX is a trademark of CSR plc. Other trademarks and trade names are those of their respective owners. All specifications are subject to change without prior notice. Use of this product is subject to a limited hardware warranty. Actual contents may differ slightly from those pictured. The software included in this packaging may not be used separately from the hardware. Before using the software, you must agree to be bound by the terms and conditions of the end user license agreement.

Version 1.0

May 2014