

CREATIVE®

X-Fi®  
SONIC CARRIER™



## USER'S MANUAL

Creative X-Fi Sonic Carrier Subwoofer (Model MF8240)

For the latest information, visit: [www.creative.com/support/soniccarrier](http://www.creative.com/support/soniccarrier)

# Package Contents

## Subwoofer

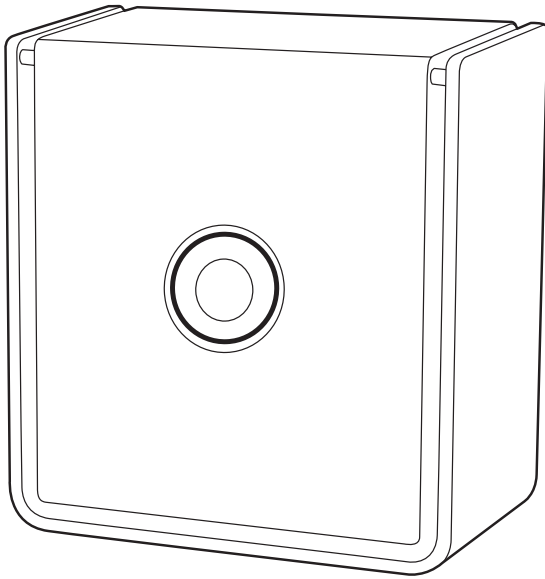

### SPECIFICATION

Product name: CREATIVE X-FI SONIC CARRIER SUBWOOFER  
Model Number: MF8240  
Output Power: 600W  
Input rating: 100 - 240V ~ 50/60Hz 120W  
Operating temperature range: 0°C to 45°C  
Dimensions (L x W x H): 531 x 306 x 582mm (20.9" x 12.0" x 22.9")  
Weight: 27kg (59.5 lbs)

Wireless audio link  
Operating Frequency: 2412 – 2464MHz  
RF Output Power: <17dBm

## Accessories box

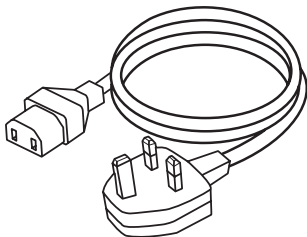

Power cable

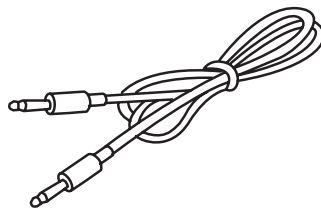

Link cable



- User Manual
- Safety and regulatory leaflets

## Care for your Creative Sonic Carrier Subwoofer

### Cabinet

The Cabinet of the Sonic Carrier Subwoofer is finely crafted from wood finished in vinyl laminate or high gloss lacquer; and should be treated as you would furniture with similar materials and finishes. Dust lightly with a soft, clean lint-free cloth, avoiding abrasives and spirit based cleaners. If necessary, wipe carefully with a cloth slightly dampened with glass cleaner to remove stubborn soil and marks.

### Grilles

The acoustically transparent fabric grille protects the subwoofer driver units, and must not be removed. This could be carefully cleaned using a lint brush, be careful not to press in and deform the drivers under the grille. The space between the grille and the cabinet could be dusted very carefully with a soft dry brush. Avoid touching the woofer diaphragm.

### General care information

Avoid damp, direct sunlight and temperature extremes. The ventilation and ports should not be impeded by covering the ventilation openings with items, such as newspapers, table-cloths, curtains, etc. No naked flame sources, such as lighted candles, should be placed on the apparatus.

# Warranty

## Creative X-Fi Sonic Carrier- Limited Hardware Warranty

Creative Labs Pte Ltd and its affiliates ("Creative") warrants that the retail purchased Creative-branded hardware product herein ("Product") is free of material defects in materials and workmanship ("Defect(s)") that result in Product failure during normal consumer usage for the Warranty Period, according to the following terms and conditions:

1. This limited hardware warranty extends only to the original end-user purchaser and holder of this warranty ("You" or "Your") and is not transferable or assignable to any subsequent purchaser.
2. You must provide proof of original purchase of the Product by a dated itemized receipt to be eligible for this limited warranty.
3. The limited warranty is ONLY applicable in the country or territory where the Product was purchased from an authorized retailer/reseller and excludes any product that has not been purchased as new or is obtained as a result of the purchase of a non-Creative product.
4. If a Defect arises and a valid claim is received during the Warranty Period (as provided below), Creative will at its sole option, service the Product at no charge using new or refurbished replacement parts at our sole discretion. Please note that:
  - a. The limited warranty for the Product is for twenty-four (24) months (excluding all wear and tear), subject to certain exceptions as stated in the EU Directive 1999/44/EC\*\* from the date of delivery ("Warranty Period"). The Warranty Period will be extended by each whole day that the Product is out of Your possession for repair under this warranty.
  - b. Creative will cover the labor charges incurred by Creative in repairing or replacing the defective parts during the Warranty Period from the date of your purchase.
  - c. You will not have to pay for any such replacement parts.
  - d. Creative also warrants that the repaired or replaced parts will be free from defects in material and workmanship for the remainder of the Warranty Period.
  - e. For the limited warranty of the Product's Liquid Crystal Display, please refer to the Creative Support Web Page at [www.creative.com/support](http://www.creative.com/support).
5. This warranty gives You specific legal rights. You may also have other rights, which vary from state to state and country to country. The terms of this warranty do not exclude such rights or limit them. Your statutory rights are unaffected. Some states and countries do not allow (i) exclusions of, or limitations on, certain liabilities or warranties, including but not limited to how long a warranty lasts, the exclusion or limitation of incidental or consequential damages, or the exclusion of liability for injury (including death) caused by negligence, (ii) the inclusions of certain asymmetrical terms in warranties, or (iii) the expiration of all legal claims after a fixed time, so certain of the above limitations, exclusions or asymmetrical terms may not apply to You depending on the relevant jurisdiction. If adjudged invalid, such term(s) would be severable without affecting the validity of the other terms.
6. Creative does not warrant uninterrupted or error-free operation of the Product. Creative is not responsible for damage arising from failure to follow all or any instructions relating to the Product's use. Creative is not under any obligation to support the Product for all operating environments, including but not limited to, interoperability with both current and future versions of software or hardware.
7. For Products that are capable of storing data: Creative is not responsible or liable for any data stored on the Product that is lost, deleted or becomes otherwise inaccessible. All data may be deleted from the Product during servicing. You should remove or make a backup copy of any data stored on the Product before sending the Product to Creative.
8. If a problem develops during the Warranty Period, please refer to [www.creative.com/support](http://www.creative.com/support) or contact Your retailer/reseller. Please note that: (i) You must provide proof of original purchase of the Product by a dated itemized receipt; (ii) You shall bear the cost of shipping (or otherwise transporting) the Product to Creative. Creative will bear the cost of shipping (or otherwise transporting) the Product back to You after completing the warranty service; (iii) Before You send the Product to Creative, You must be issued a Return Merchandise Authorisation ("RMA") number from [www.creative.com/support](http://www.creative.com/support). Clearly write the RMA number on the outside of the package containing the Product being sent to Creative. Creative will not accept a return that does not have a RMA number on the outer packaging; and (iv) You can only return the defective Product(s) not excluded under Section 9 below. Creative is not responsible for other products or accessories returned with the defective Product(s). Creative reserves the right to change the method by which Creative may provide warranty service to you, and your Product's eligibility to receive a particular method of service. Service will be limited to the options available in the country where service is requested. Service options, parts availability and response times may vary according to country. For further details on Creative Warranty terms, Product returns and repair procedure, Creative customer support services and contact information, please refer to the support section of Creative's web site at [www.creative.com/support](http://www.creative.com/support).
9. The limited warranty does not apply to:
  - a. Consumable parts, such as batteries or protective coatings that, due to their nature, tend to diminish over time, unless failure has occurred due to a defect in materials or workmanship;
  - b. Damage caused by normal wear and tear, abnormal use or conditions, misuse, neglect, abuse, accident, improper handling or storage, defects or damages resulting from service, testing, adjustment, installation, maintenance, alteration, including without limitation, software changes, or modification in any way by someone other than Creative or its authorised service centres, improper use of any electrical source, undue physical or electrical stress, operator error, non-compliance with instructions or other acts which are not the fault of Creative, including damage or loss during shipment or transit.
  - c. Damage from external causes such as floods, storms, fires, sand, dirt, earthquakes, an Act of God, exposure to sunlight, weather, moisture, heat, vibration or corrosive environments, electrical surges, battery leakage, theft, or damage caused by the connection to other products not recommended for interconnection.
  - d. Damage or loss of data due to (i) interoperability with either or both current and future versions of operating systems or other current or future software and hardware, (ii) a computer virus, worm, spyware, Trojan horse or memory content corruption, or (iii) malfunction or defect of the Product.
  - e. Counterfeit products/parts or any accompanying products/parts that are incompatible with the Product.
  - f. Any Product that: (i) has had its serial number altered, defaced or removed; (ii) shows evidence of tampering; (iii) mismatched board serial numbers; or (iv) has non-conforming or non-Creative housing or casing.
  - g. Any accessories including but not limited to disposable alkaline batteries, removable fuses, screen protectors, plugs and pouches.
  - h. Any defect occurring after the expiration of the Warranty Period or where Creative was not advised in writing of an alleged defect or malfunction within seven (7) days after the expiration of the Warranty Period.
10. Any Product determined by Creative to be warranty-expired, warranty-void or not in need of repair will be subject to a minimum non-refundable diagnostic and handling fee. In the event that You fail to make the payment, Creative may, at its sole discretion, dispose of the Product without notice and liability to You.
11. Subject to any non-excludable limit under applicable law, the maximum liability under this limited warranty is the original price paid for the Product (excluding any shipping and additional charges). Creative and its affiliated companies will not be liable for any other losses or damage unless liability is non-excludable under applicable law. The remedy stated is Your exclusive remedy for breach of warranty. Any action or lawsuit for breach of this limited warranty must be commenced within eighteen (18) months following the original purchase of the Product or within the limitation period under applicable law.
12. IN SO FAR AS PERMITTED BY LAW, THE PRODUCT AND THE SERVICED PRODUCT IS PROVIDED "AS IS". TO THE EXTENT PERMITTED BY APPLICABLE LAW, CREATIVE AND ITS AFFILIATED COMPANIES HEREBY DISCLAIM THE APPLICABILITY OF ANY IMPLIED WARRANTY OF MERCHANTABILITY, FITNESS FOR A PARTICULAR PURPOSE OR USE FOR THE PRODUCT AND/OR THE SERVICED PRODUCT. CREATIVE AND ITS AFFILIATED COMPANIES WILL NOT BE LIABLE FOR ANY INDIRECT, INCIDENTAL, SPECIAL, PUNITIVE OR CONSEQUENTIAL DAMAGES, INCLUDING BUT NOT LIMITED TO ANY LOST PROFITS, SAVINGS, DATA, OR LOSS OF USE, ANY THIRD PARTY CLAIMS, AND ANY INJURY TO PROPERTY OR BODILY INJURY (INCLUDING DEATH) TO ANY PERSON, ARISING FROM OR RELATING TO THE USE OF THE PRODUCT OR ARISING FROM BREACH OF THE WARRANTY, BREACH OF CONTRACT, NEGLIGENCE, TORT, OR STRICT LIABILITY, EVEN IF CREATIVE OR ANY OF ITS AFFILIATED COMPANIES HAS BEEN ADVISED OF THE POSSIBILITY OF SUCH DAMAGES.
13. For Australia only: Our goods come with guarantees that cannot be excluded under the Australian Consumer Law. You are entitled to a replacement or refund for a major failure and for compensation for any other reasonably foreseeable loss or damage. You are also entitled to have the goods repaired or replaced if the goods fail to be of acceptable quality and the failure does not amount to a major failure. Goods presented for repair may be replaced by refurbished goods of the same type rather than being repaired. Refurbished parts may be used to repair the goods. (Creative Technology Ltd, 31 International Business Park, #03-01 Creative Resource, Singapore 609921. Telephone: +65 6895 4433 (standard international call charges apply.))
14. This is the entire warranty and supersedes all prior and contemporaneous agreements or understandings, oral or written, relating to warranty coverage for the Product, and no representation, promise or condition not contained herein will modify these terms.
15. Update(s) of this Limited Hardware Warranty may be posted at [www.creative.com/support](http://www.creative.com/support). An Update will replace any earlier version upon posting on the web site. You are advised to check for Update(s).

\*\* A seller in the European Union (EU) may be entitled to refuse to repair or replace the goods if it is (i) impossible or (ii) disproportionate (eg. where the costs are unreasonably high for the seller) to do so, taking into account the value the goods would have had (if there were no lack of conformity), the significance of the lack of conformity and where an alternative remedy would be completed without significant inconvenience to the consumer. In such cases, the consumer may ask for an appropriate reduction of the price or have the contract rescinded. The consumer is not entitled to have the contract rescinded if the lack of conformity (or defect or fault) is minor. In which case, the seller is entitled to turn down a request for rescission of the contract in such a situation. For further details, please refer to Articles 3(3), 3(5) and 3(6) of the EU Directive 1999/44/EC.

# Connecting Electrical Power

Connect the power cords to the main unit and subwoofers, socket location are located at the back of the units and are marked below. Connect power cords to the mains socket.

For more information about the power supply and power consumption, refer to the label attached to the product.  
(Main Unit : Bottom panel, Subwoofer : Rear panel)

## Main Unit

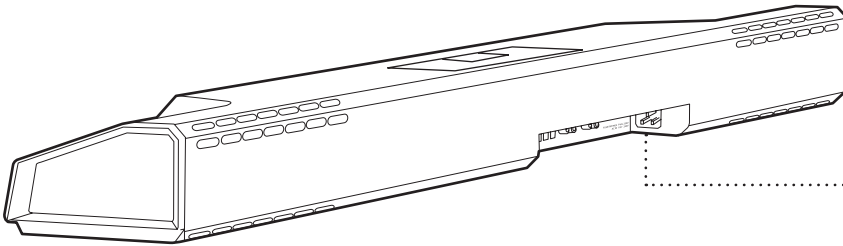
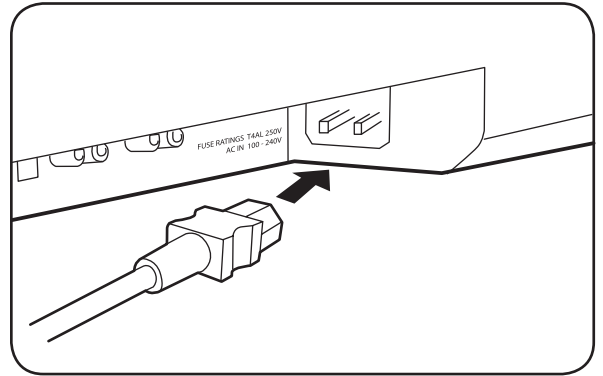

## Subwoofer

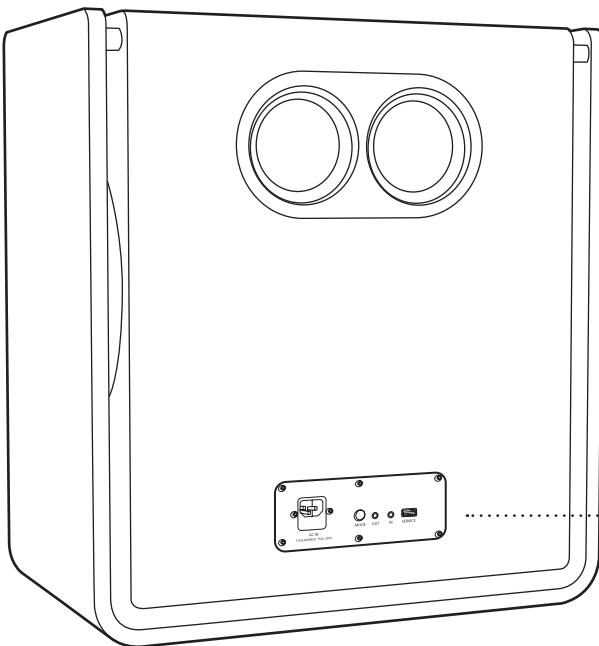
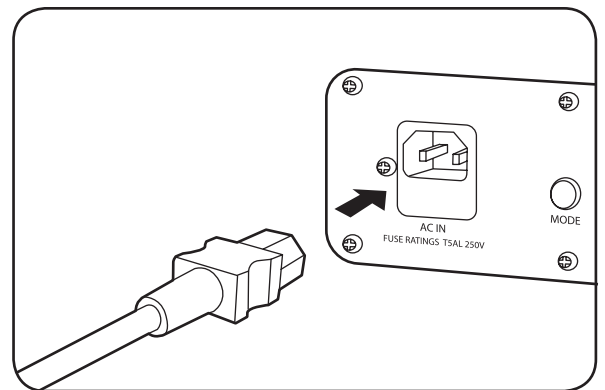

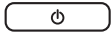

# Setting Up the Wireless Subwoofer Connection

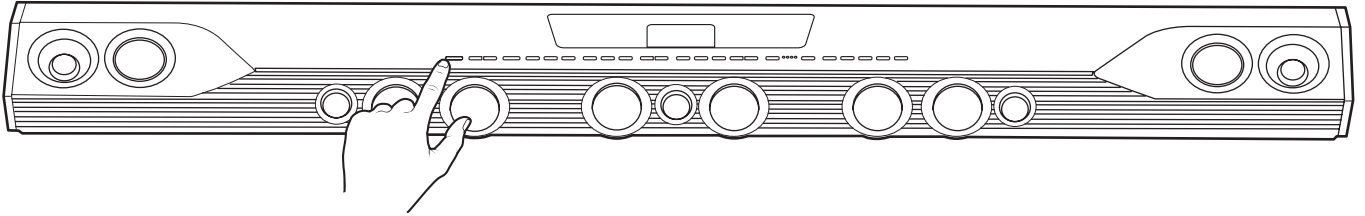
1. Ensure the Main unit and Subwoofer are placed within 3 metre for the setup process.
2. Ensure mains power is connected and switched on.
3. Power on the Main unit by pressing the power (  ) button. The boot up process may take around a minute.

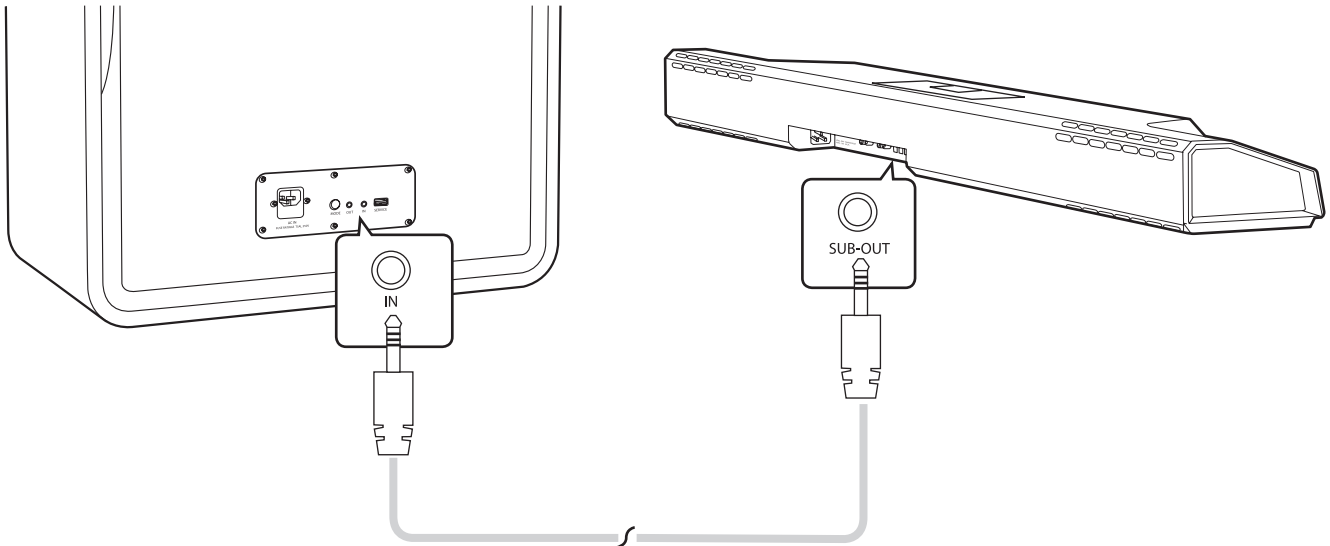

4. Connect the link cable (bundled with the subwoofer) between the main unit and the subwoofer. On the Main unit, the cable should be plugged into the Sub-Out connector. On the Subwoofer, the other end of the cable should be plugged into the In connector.



5. Press and hold the "  " button until the main display shows a "Waiting for subwoofer connection" message is shown. Upon successful setup, a message indicating "Subwoofer Connected" would be displayed.

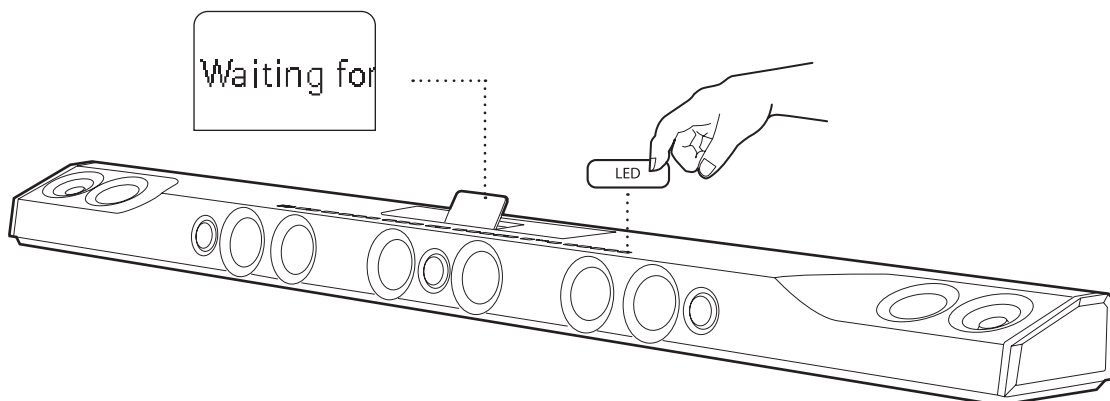

CREATIVE®

[soniccarrier.com](http://soniccarrier.com)

Complies with  
IMDA Standards  
DA107311

© 2017 Creative Technology Ltd. All rights reserved. Creative, the Creative logo, X-Fi, the X-Fi logo, Sonic Carrier and SuperWide X-Fi are trademarks or registered trademarks of Creative Technology Ltd in the United States and/or other countries. Dolby, Dolby Atmos, and the double-D symbol are registered trademarks of Dolby Laboratories. Wi-Fi is a trademark of Wi-Fi Alliance. Android is a trademark of Google Inc. The *Bluetooth*® word mark and logos are registered trademarks owned by Bluetooth SIG, Inc. and any use of such marks by Creative Technology Ltd is under license. Other trademarks and trade names are those of their respective owners. All specifications are subject to change without notice. Actual product may differ from slightly from images shown. All images are for illustration purposes only. State of California Proposition 65 WARNING: This product may expose you to chemicals known to the State of California to cause cancer and birth defects or other reproductive harm. Explanatory Note: To meet the requirements of Proposition 65, it is our responsibility to notify consumers in the State of California that they may be exposed to chemicals that are known to cause cancer and/or reproductive toxicity. It does not mean that the product is in violation of any product-safety standards or requirements. The exposure may be below the level of concern, or even zero. For additional information, visit [www.P65Warnings.ca.gov](http://www.P65Warnings.ca.gov).

PN 03MF82400000 RevA