

Crestron **CEN-RFGW-EX**

infiNET EX™ Gateway

Operations & Installation Guide



This document was prepared and written by the Technical Documentation department at:



Crestron Electronics, Inc.
15 Volvo Drive
Rockleigh, NJ 07647
1-888-CRESTRON

Industry Compliance

Federal Communications Commission (FCC) Compliance Statement

FCC ID: EROCEN-RFGW-EX

This device complies with part 15 of the FCC rules. Operation is subject to the following two conditions: (1) this device may not cause harmful interference and (2) this device must accept any interference received, including interference that may cause undesired operation.

CAUTION: Changes or modifications not expressly approved by the manufacturer responsible for compliance could void the user's authority to operate the equipment.

NOTE: This equipment has been tested and found to comply with the limits for a Class B digital device, pursuant to part 15 of the FCC Rules. These limits are designed to provide reasonable protection against harmful interference in a residential installation. This equipment generates, uses and can radiate radio frequency energy and if not installed and used in accordance with the instructions, may cause harmful interference to radio communications. However, there is no guarantee that interference will not occur in a particular installation. If this equipment does cause harmful interference to radio or television reception, which can be determined by turning the equipment off and on, the user is encouraged to try to correct the interference by one or more of the following measures:

- Reorient or relocate the receiving antenna.
 - Increase the separation between the equipment and receiver.
 - Connect the equipment into an outlet on a circuit different from that to which the receiver is connected.
 - Consult the dealer or an experienced radio/TV technician for help.
-

Industry Canada (IC) Compliance Statement

IC: 5683C-CENRFGWEX

Operation is subject to the following two conditions:

1. This device may not cause interference, and
 2. This device must accept any interference, including interference that may cause undesired operation of the device.
-

To satisfy RF exposure requirements, this device and its antenna must operate with a separation distance of at least 20 centimeters from all persons and must not be co-located or operating in conjunction with any other antenna or transmitter.

Shielded LAN cable must be used.

Contents

infiNET EX™ Gateway: CEN-RFGW-EX	1
Introduction	1
Features and Functions	2
Specifications	3
Physical Description	5
Setup	9
Network Wiring	9
Identity Code	9
Installation	10
Hardware Hookup	11
Programming Software	12
Earliest Version Software Requirements for the PC	12
Programming with Crestron SystemBuilder	12
Programming with SIMPL Windows	12
Example Program	14
Uploading and Upgrading	15
Establishing Communication	15
Programs and Firmware	16
Program Checks	16
Operation	18
Problem Solving	20
Troubleshooting	20
Reference Documents	22
Further Inquiries	23
Future Updates	23
Appendix A: The RF Spectrum	24
Appendix B: Optimum RF Reception Guidelines	25
Minimize Interference	25
Gateway Placement	25
Antenna Orientation	26
Return and Warranty Policies	28
Merchandise Returns / Repair Service	28
CRESTRON Limited Warranty	28

infiNET EX™ Gateway: CEN-RFGW-EX

Introduction

The CEN-RFGW-EX gateway is an RF wireless transceiver designed for use with the MLX-2 infiNET EX™ LCD Handheld Remote and other Crestron® infiNET EX devices as part of a Crestron control system. “Wi-Fi friendly” RF technology permits selection from 16 ISM* channels within the 2.4 GHz spectrum to minimize the possibility of interference with other RF equipment including 802.11 devices. The CEN-RFGW-EX affords a range of approximately 100 feet (30 meters) indoors.

Up to 16 MLX-2 remotes or other infiNET EX devices, may be associated with a single CEN-RFGW-EX. Setup is simple, utilizing dynamic discovery to locate and acquire each remote automatically. Each wireless connection is monitored continuously, diligently keeping track when remotes go to sleep or wander out of range and restoring communications seamlessly when any remote reappears on the network. More than just a wireless bridge, the CEN-RFGW-EX actually functions as a proxy for each MLX-2, processing every button press and display change right onboard. So when a remote goes to sleep or out of range, the gateway continues communicating with the control system, keeping sync with every command and updating the remote’s display the instant it awakens or reconnects.

* Industrial, Scientific and Medical; refers to frequency range used for unlicensed communications applications, such as Wi-Fi.

PoE (Power-over-Ethernet) powers the \CEN-RFGW-EX right through the network wiring, eliminating the need for a separate wall-wart power supply. The CEN-RFGW-EX is available with a PoE Injector, PWE-4803RU, which simply connects inline with the Ethernet cable connected to the gateway, allowing for installation at any convenient location. Or, using Crestron's 5-port PoE switch (CEN-SW-POE-5, sold separately), up to four gateways and other PoE devices can be powered from a single location, simplifying design and wiring.

Features and Functions

- infiNET EX 2-way RF wireless transceiver/gateway
- Manages up to 16 MLX-2 handheld remotes or other Crestron infiNET EX devices
- Up to 100 feet (30 meters) range indoors
- Dynamic discovery for fast, easy setup
- “Wi-Fi friendly” channel selection
- Built-in RF network diagnostics
- Ethernet control system interface
- PoE “Power-over-Ethernet” compatible

Specifications

Specifications for the CEN-RFGW-EX are listed in the following table.

CEN-RFGW-EX Specifications

SPECIFICATION	DETAILS
Wireless RF Transceiver	infiNET EX 2-way RF, 2.4 GHz ISM Channels 11-26 (2400 to 2483.5 MHz), IEEE 802.15.4 compliant; Maximum 16 remotes per gateway; Default RF channel is 15
Range (typical)	100 feet (30 meters) indoors, subject to site-specific conditions
Ethernet	10BASE-T/100BASE-TX, auto-switching, auto-negotiating, auto-discovery, full/half duplex, TCP/IP, UDP/IP, CIP, DHCP, IEEE 802.3U and 802.3af compliant; Unit ships with DHCP enabled.
Power Requirements PoE	<45 mA @ 48 Volts DC
Default Net ID	2F
Minimum 2-Series Control System Update File ^{1,2}	Version 3.155.1240 or later
Environmental Temperature	41° to 104° F (5° to 40° C)
Humidity	10% to 90% RH (non-condensing)
Heat Dissipation	7 BTU/Hr

(Continued on following page)

CEN-RFGW-EX Specifications (Continued)

SPECIFICATION	DETAILS
Enclosure	Aluminum with polycarbonate label overlay, freestanding or surface mount with (4) integral mounting flanges.
Dimensions (without antenna)	
Height	6.41 in (16.27 cm)
Width	3.91 in (9.94 cm)
Depth	1.43 in (3.62 cm)
Weight	13.1 oz (372.7 g)
Available Accessories	
PWE-4803RU	PoE Injector
CEN-SW-POE-5	5-Port PoE Switch

1. The latest software versions can be obtained from the Crestron website. Refer to the NOTE following these footnotes.
2. Crestron 2-Series control systems include the AV2 and PRO2. Consult the latest Crestron Product Catalog for a complete list of 2-Series control systems.

NOTE: Crestron software and any files on the website are for authorized Crestron dealers and Crestron Authorized Independent Programmers (CAIP) only. New users may be required to register to obtain access to certain areas of the site (including the FTP site).

Physical Description

This section provides information on the connections, controls and indicators available on your CEN-RFGW-EX.

CEN-RFGW-EX Physical View



CEN-RFGW-EX Overall Dimensions (Top, Front, Side and Bottom Views)

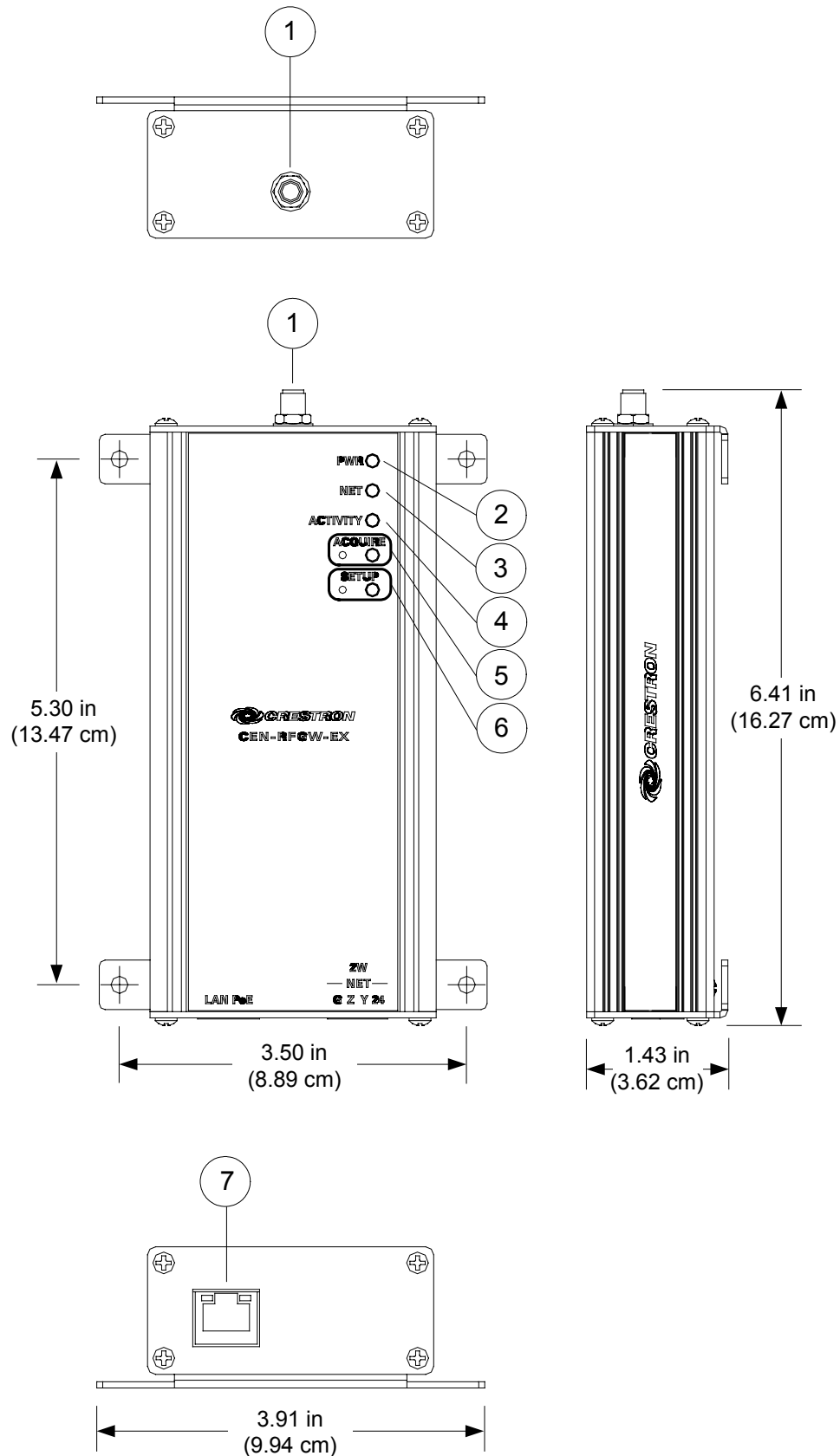

Connectors, Controls & Indicators

#	CONNECTORS, CONTROLS & INDICATORS	DESCRIPTION																				
1	ANTENNA	(1) Connection for supplied antenna																				
2	PWR LED	(1) Green LED, indicates operating power supplied from PoE																				
3	NET LED	(1) Yellow LED, indicates communication with the Cresnet system																				
4	ACTIVITY LED	(1) Red LED, indicates wireless communications																				
5	ACQUIRE (Button and LED)	(1) Recessed pushbutton with red LED, used to set up connections with wireless devices																				
6	SETUP (Button and LED)	(1) Recessed pushbutton with red LED, used to set up connection with the control system via Cresnet or Ethernet																				
7	 <p>LAN PoE^{1, 2}</p>	<p>(1) 8-wire RJ-45 with two LED indicators; 10BASE-T/100BASE-TX Ethernet port, 802.3af Power over Ethernet compliant; Green LED indicates link status; Yellow LED indicates Ethernet activity</p> <table border="1"> <thead> <tr> <th>PIN</th> <th>SIGNAL</th> <th>PIN</th> <th>SIGNAL</th> </tr> </thead> <tbody> <tr> <td>1</td> <td>TX +</td> <td>5</td> <td>N/C</td> </tr> <tr> <td>2</td> <td>TX -</td> <td>6</td> <td>RC -</td> </tr> <tr> <td>3</td> <td>RC+</td> <td>7</td> <td>N/C</td> </tr> <tr> <td>4</td> <td>N/C</td> <td>8</td> <td>N/C</td> </tr> </tbody> </table>	PIN	SIGNAL	PIN	SIGNAL	1	TX +	5	N/C	2	TX -	6	RC -	3	RC+	7	N/C	4	N/C	8	N/C
PIN	SIGNAL	PIN	SIGNAL																			
1	TX +	5	N/C																			
2	TX -	6	RC -																			
3	RC+	7	N/C																			
4	N/C	8	N/C																			

1. To determine which is pin 1 on the cable, hold the cable so that the end of the eight pin modular jack is facing away from you, with the clip down and copper side up. Pin 1 is on the far left.
2. The pin out table indicates signal connections. DC power applied by Ethernet power sourcing equipment (PSE) can connect to either signal pins or N/C pins.

PRELIMINARY

Setup

Network Wiring

Ethernet

The CEN-RFGW-EX can also use high-speed Ethernet for communications between the device and a control system, computer, digital media server and other IP-based devices.

For information on connecting Ethernet devices in a Crestron system, refer to the latest version of the Crestron e-Control® Reference Guide (Doc. 6052), which is available for download from the Crestron website (www.crestron.com/manuals).

Identity Code

IP ID

The IP ID is set within the CEN-RFGW-EX's table using Crestron Toolbox. For information on setting an IP table, refer to the Crestron Toolbox help file. The IP IDs of multiple CEN-RFGW-EX devices in the same system must be unique.

When setting the IP ID, consider the following:

- The IP ID of each unit must match an IP ID specified in the SIMPL™ Windows® program.
- Each device using IP to communicate with a control system must have a unique IP ID.

Installation

Ventilation

To prevent overheating, do not operate this product in an area that exceeds the environmental temperature range listed in the table of specifications. Consider using forced air ventilation and/or incrementing the spacing between units to reduce overheating. Consideration must be given if installed in a closed or multi-unit rack assembly since the operating ambient temperature of the environment may be greater than the room ambient temperature. Contact with thermal insulating materials should be avoided on all sides of the unit.

Placement Tips

When installing a CEN-RFGW-EX near another CEN-RFGW-EX, for optimum performance, keep the following in mind:

- Do not place multiple gateways on the same channel. Refer to “Appendix A: The RF Spectrum” on page 24 for details.
- Gateways on adjacent channels should be at least 12 feet (3.7 meters) apart.
- Gateways on non-adjacent channels should be at least three feet (0.9 meters) apart.

When installing a CEN-RFGW-EX near a Wi-Fi access point, for optimum performance, keep the following in mind:

- Gateways on RF channels adjacent to operating Wi-Fi channels should be placed at least 12 feet (3.7 meters) from the nearest Wi-Fi access point.
- Gateways on RF channels that are non-adjacent to Wi-Fi channels should be located at least six feet (1.8 meters) from the nearest Wi-Fi access point.

For more information on RF channels and their interaction with the Wi-Fi spectrum, refer to “Appendix A: The RF Spectrum” on page 24. For additional information on optimal gateway placement, refer to “Appendix B: Optimum RF Reception Guidelines” which starts on page 25.

Hardware Hookup

Make the necessary connections as called out in the illustrations that follow this paragraph.

Hardware Connections for the CEN-RFGW-EX (Top View)

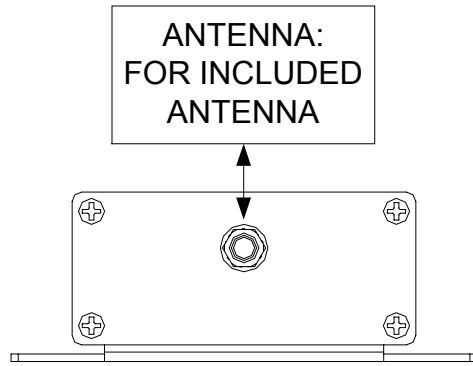

Hardware Connections for the CEN-RFGW-EX (Bottom View)

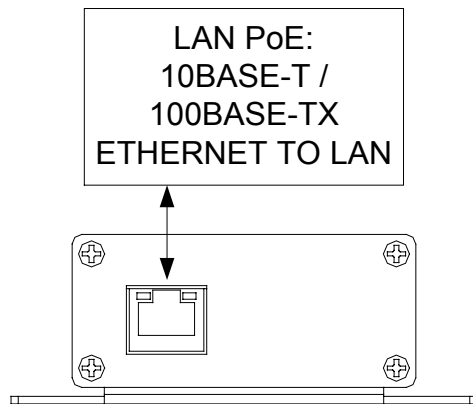

NOTE: Antenna must be attached directly to the antenna connector. It should not be extended with a cable.

Programming Software

Have a question or comment about Crestron software?

Answers to frequently asked questions (FAQs) can be viewed in the Online Help section of the Crestron website. To post a question or view questions you have submitted to Crestron's True Blue Support, log in at <http://support.crestron.com>. First-time users will need to establish a user account.

Earliest Version Software Requirements for the PC

NOTE: Crestron recommends that you use the latest software to take advantage of the most recently released features. The latest software is available from the Crestron website.

Crestron has developed an assortment of Windows®-based software tools to develop an infiNET system. For the minimum recommended software versions, visit the Version Tracker page of the Crestron website (www.crestron.com/versiontracker).

Programming with Crestron SystemBuilder

Crestron SystemBuilder is the easiest method of programming but does not offer as much flexibility as SIMPL Windows. For additional details, download SystemBuilder from the Crestron website and examine the extensive help file.

Programming with SIMPL Windows

NOTE: While SIMPL Windows can be used to program the CEN-RFGW-EX, it is recommended to use SystemBuilder for configuring a system.

SIMPL Windows is Crestron's premier software for programming Crestron control systems. It is organized into two separate but equally important "Managers".

Configuration Manager

Configuration Manager is the view where programmers “build” a Crestron control system by selecting hardware from the *Device Library*.

- To incorporate the CEN-RFGW-EX into the system, drag the CEN-RFGW-EX from the Wireless Receivers | Wireless Receivers (RF) folder of the *Device Library* and drop it in the *System Views*.

Locating the CEN-RFGW-EX in the Device Library

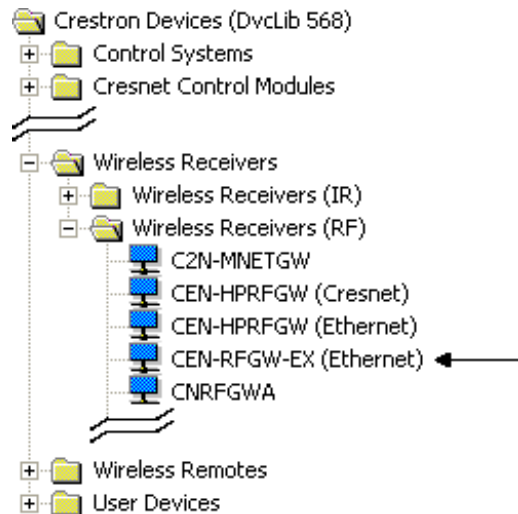

- The system tree of the control system displays the device in the appropriate slot with a default IP ID, as shown in the following illustration.

C2Net Device, Slots 8

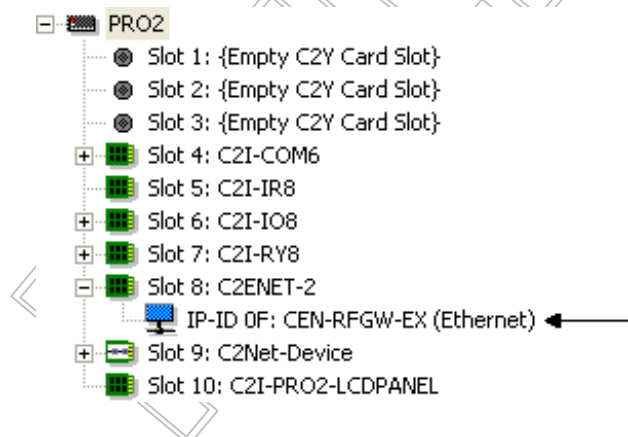

- Additional CEN-RFGW-EX devices are assigned different IP ID numbers as they are added.
- If necessary, double click a device to open the “Device Settings” window and change the IP ID, as shown in the following figure.

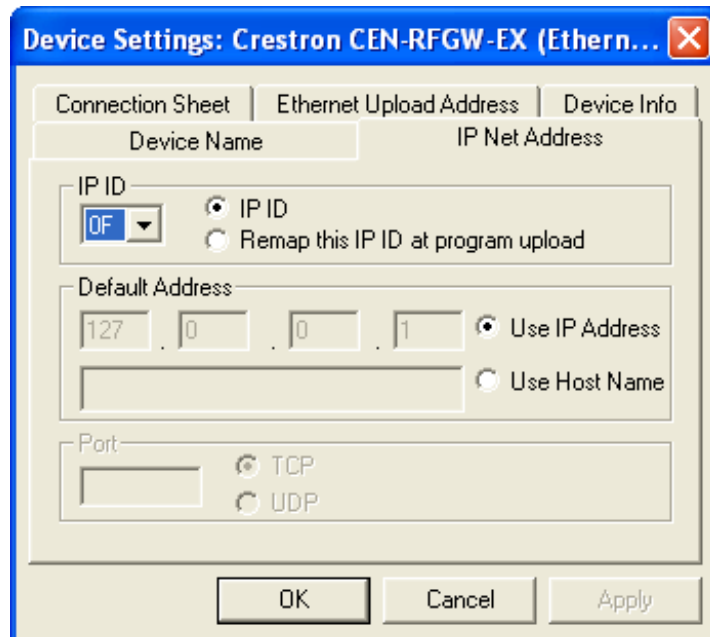
“CEN-RFGW-EX Device Settings (Ethernet)” Window

- The ID code specified in the SIMPL Windows program must match the Net ID or IP ID of each unit. Refer to “Identity Code” on page 9.

Program Manager

Program Manager is the view where programmers “program” a Crestron control system by assigning signals to symbols.

The symbol can be viewed by double clicking on the icon or dragging it into *Detail View*. Each signal in the symbol is described in the SIMPL Windows help file (F1).

Example Program

An example program for the CEN-RFGW-EX is available from the Crestron website (www.crestron.com/exampleprograms).

Uploading and Upgrading

Crestron recommends using the latest programming software and that each device contains the latest firmware to take advantage of the most recently released features. However, before attempting to upload or upgrade it is necessary to establish communication. Once communication has been established, files (for example, programs or firmware) can be transferred to the control system (and/or device). Finally, program checks can be performed (such as changing the device ID or creating an IP table) to ensure proper functioning.

Establishing Communication

Use Crestron Toolbox for communicating with the CEN-RFGW-EX; refer to the Crestron Toolbox help file for details.

Ethernet Communication



- Enter the IP address, IP mask, and default router of the CEN-RFGW-EX via the Crestron Toolbox (**Functions | Ethernet Addressing**); otherwise, leave DHCP enabled. (The unit ships with DHCP enabled.)
- Confirm Ethernet connections between CEN-RFGW-EX and PC. If connecting through a hub or router, use CAT5 straight through cables with 8-pin RJ-45 connectors. Alternatively, use a CAT5 crossover cable to connect the two LAN ports directly without using a hub or router.
- Use the Address Book in Crestron Toolbox to create an entry for the CEN-RFGW-EX with the CEN-RFGW-EX's TCP/IP communication parameters.
- Display the "System Info" window (click the  icon) and select the CEN-RFGW-EX entry.

Programs and Firmware

Program or firmware files may be distributed from programmers to installers or from Crestron to dealers. Firmware upgrades are available from the Crestron website as new features are developed after product releases. One has the option to upload programs via the programming software or to upload and upgrade via the Crestron Toolbox. For details on uploading and upgrading, refer to the SIMPL Windows help file or the Crestron Toolbox help file.

SIMPL Windows

If a SIMPL Windows program is provided, it can be uploaded to the control system using SIMPL Windows or Crestron Toolbox.

VisionTools Pro-e

Upload the VT Pro-e file for the MLX-2 (or other infiNET EX device) using VT Pro-e or Crestron Toolbox.

Firmware

Check the Crestron website to find the latest firmware. (New users may be required to register to obtain access to certain areas of the site, including the FTP site.)

Upgrade CEN-RFGW-EX firmware via Crestron Toolbox.

- Establish communication with the CEN-RFGW-EX and display the “System Info” window.
- Select **Functions | Firmware...** to upgrade the CEN-RFGW-EX firmware.

Program Checks

Ethernet Connections

Display the “System Info window (click the  icon) and select the **Functions** menu to display actions that can be performed on the CEN-RFGW-EX.

Be sure to use Crestron Toolbox to create the CEN-RFGW-EX IP table.

- Select **Functions | IP Table Setup**.
- Add, modify or delete entries in the IP table. The CEN-RFGW-EX can have only one IP table entry.
- A defined IP table can be saved to a file or sent to the device.

Edit the control system’s IP table to include an entry for the CEN-RFGW-EX. The entry should list the CEN-RFGW-EX’s IP ID (specified on the CEN-RFGW-EX’s IP table) and the internal gateway IP address 127.0.0.1.

NOTE: Only one IP table entry is allowed. The unit can talk to only one processor over IP.

PRELIMINARY

Operation

Operating Channel

The operating channel of the CEN-RFGW-EX must be set prior to operation using Crestron Toolbox. The CEN-RFGW-EX can operate on one of 16 channels. The CEN-RFGW-EX can operate on a fixed channel that is set by the installer. The default RF channel is 15.

For optimum performance when installing a CEN-RFGW-EX in a Wi-Fi environment, do not set the CEN-RFGW-EX to a channel within a Wi-Fi channel band. Crestron recommends channel 15 or channel 20.

- Gateway channels 11-14 are within Wi-Fi channel 1 band.
- Gateway channel 15 is adjacent to Wi-Fi channels 1 and 6.
- Gateway channels 16-19 are within Wi-Fi channel 6 band.
- Gateway channel 20 is adjacent to Wi-Fi channels 6 and 11.
- Gateway channels 21-24 are within Wi-Fi channel 11 band.
- Gateway channel 25 is adjacent to Wi-Fi channel 11.
- Gateway channel 26 is neither within or adjacent to any Wi-Fi band.

For detailed information on RF channels, refer to “Appendix A: The RF Spectrum” on page 24.

After establishing communication with the CEN-RFGW-EX (refer to “Establishing Communication” which starts on page 15), use Crestron Toolbox to set the operating channel.

RF Channel

Each gateway can communicate with up to 16 infiNET EX devices on the same channel. Each device must have an RF channel assignment that matches the RF channel assignment of the gateway.

There are 16 possible channels ranging from 11 to 26.

Setting RF channel is done from a PC via Crestron Toolbox. To access this in Toolbox, select **Functions | infiNET EX Gateway...** Refer to the Toolbox Help file and search for “infiNET EX Gateway” for more details.

Acquiring the
MLX-2
(or other
infiNET EX
device)

MLX-2s and other infiNET EX devices can communicate with a CEN-RFGW-EX only if they have been acquired by that CEN-RFGW-EX. The *Acquire* mode can be activated from Crestron Toolbox (recommended) or with the **ACQUIRE** button on the CEN-RFGW-EX.

NOTE: To access this in Toolbox, select **Functions | infiNET EX Gateway...** Refer to the Toolbox Help file and search for “infiNET EX Gateway” for more details.

NOTE: Use Toolbox to set the RF channel before starting the acquire process. The default RF channel is 15. If you change the RF channel on a device, it will need to be acquired again.

NOTE: The *Acquire* mode can be activated approximately 15 seconds after applying power to the CEN-RFGW-EX.

NOTE: In an environment with multiple gateways, only one gateway should be in the *Acquire* mode at a time.

NOTE: The CEN-RFGW-EX must be placed in *Acquire* mode before an infiNET EX device is placed in the *Acquire* mode.

To acquire an MLX-2 or other infiNET EX device via the **ACQUIRE** button on the CEN-RFGW-EX:

1. Press **ACQUIRE** on the CEN-RFGW-EX to enter the *Acquire* mode. The accompanying LED will illuminate, indicating the unit is ready to link to infiNET EX devices.

NOTE: The *Acquire* mode will automatically deactivate after one hour. This default timeout period can be changed from Toolbox.

2. Bring the MLX-2 or other infiNET EX device within range of the gateway and place it in the *Acquire* mode as described in its manual. The device will be automatically acquired by the gateway within two minutes after it enters *Acquire* mode.
3. Repeat step 2 for each infiNET EX device to be acquired.
4. Press **AQQUIRE** on the CEN-RFGW-EX to exit the *Acquire* mode. The LED will turn off.

Problem Solving

Troubleshooting

The following table provides corrective action for possible trouble situations. If further assistance is required, please contact a Crestron customer service representative.

CEN-RFGW-EX Troubleshooting

TROUBLE	POSSIBLE CAUSE(S)	CORRECTIVE ACTION
PWR LED does not illuminate.	CEN-RFGW-EX is not receiving sufficient Ethernet power.	Verify that appropriate Ethernet power sourcing equipment (PSE) Power over Ethernet indicator is ON.
NET LED does not illuminate.	CEN-RFGW-EX Net ID is not set to match the Net ID of the SIMPL program.	In Crestron Toolbox, check Functions CresnetID to verify Net ID. Verify Net ID in SIMPL Windows program.
NET LED is on but unit does not communicate with infiNET EX device.	CEN-RFGW-EX is not communicating with network.	Check network cabling for solid connections and correct pinouts.
	infiNET EX device is set to wrong RF channel.	Refer to the “Setup” section of the guide for the device to verify that its RF channel is set to match the CEN-RFGW-EX channel ID.

(Continued on following page)

CEN-RFGW-EX Troubleshooting (Continued)

TROUBLE	POSSIBLE CAUSE(S)	CORRECTIVE ACTION
NET LED is on but unit does not communicate with infiNET EX device. (Continued)	infiNET EX device RF ID does not match the RF ID of the SIMPL program.	Use Crestron Toolbox to poll the network. Check the RF ID for the device, then refer to the “Setup” section of the guide for the device to set its RF ID to match the RF ID in the SIMPL program.
	infiNET EX device is not functioning correctly.	Refer to the “Problem Solving” section of the guide for the device.
Intermittent response from CEN-RFGW-EX during communication with device.	CEN-RFGW-EX is in vicinity of metal.	Verify that large amount of metal is not in vicinity of transmission.
	infiNET EX device is not functioning correctly.	Refer to the “Problem Solving” section of the guide for the device.
	infiNET EX device is out of range.	Position the device within operating range or relocate CEN-RFGW-EX. Refer to “Specifications” which starts on page 3 for details.

(Continued on following page)

CEN-RFGW-EX Troubleshooting (Continued)

TROUBLE	POSSIBLE CAUSE(S)	CORRECTIVE ACTION
CEN-RFGW-EX is not shown on Network Device Tree when polling through Toolbox. Other devices are reported.	Network wiring is incorrect.	Check network cabling for solid connections and correct pinouts.
	CEN-RFGW-EX is damaged.	Contact a Crestron customer service representative.
Multiple infiNET EX devices only operate one at a time.	Multiple infiNET EX devices are set to the same RF ID.	Use Crestron Toolbox to poll the network. Check the RF ID for the device, then refer to the “Setup” section of the guide for the device to set its RF ID to match the RF ID in the SIMPL program.

Reference Documents

The latest version of all documents mentioned within the guide can be obtained from the Crestron website (www.crestron.com/manuals). This link will provide a list of product manuals arranged in alphabetical order by model number.

List of Related Reference Documents

DOCUMENT TITLE
Crestron e-Control Reference Guide

Further Inquiries

If you cannot locate specific information or have questions after reviewing this guide, please take advantage of Crestron's award winning customer service team by calling Crestron at 1-888-CRESTRON [1-888-273-7876].

You can also log onto the online help section of the Crestron website (www.crestron.com/onlinehelp) to ask questions about Crestron products. First-time users will need to establish a user account to fully benefit from all available features.

Future Updates

As Crestron improves functions, adds new features and extends the capabilities of the CEN-RFGW-EX, additional information may be made available as manual updates. These updates are solely electronic and serve as intermediary supplements prior to the release of a complete technical documentation revision.

Check the Crestron website periodically for manual update availability and its relevance. Updates are identified as an “Addendum” in the Download column.

Appendix A: The RF Spectrum

Crestron’s RF network provides 16 RF channels in the 2.4GHz ISM* band, specifically IEEE 802.15.4 channels 11 through 26. The 16 channels define the frequencies at which the RF device will communicate.

RF devices on different channels will not communicate or interfere with each other. However, since some of the channels are in the 2.4GHz ISM band (as shown in the following diagram), interference can occur with other devices using this band, such as 802.11b/g Wi-Fi devices, Crestron infiNET™ devices or Zigbee devices, although the differing protocols will not allow a link to be established or data to be transferred. Wireless 2.4GHz telephones and microwave ovens may also cause interference with the network.

* Industrial, Scientific and Medical; refers to frequency range used for unlicensed communications applications, such as Wi-Fi.

IEEE 802.15.4 channel selection (2400 MHz PHY)

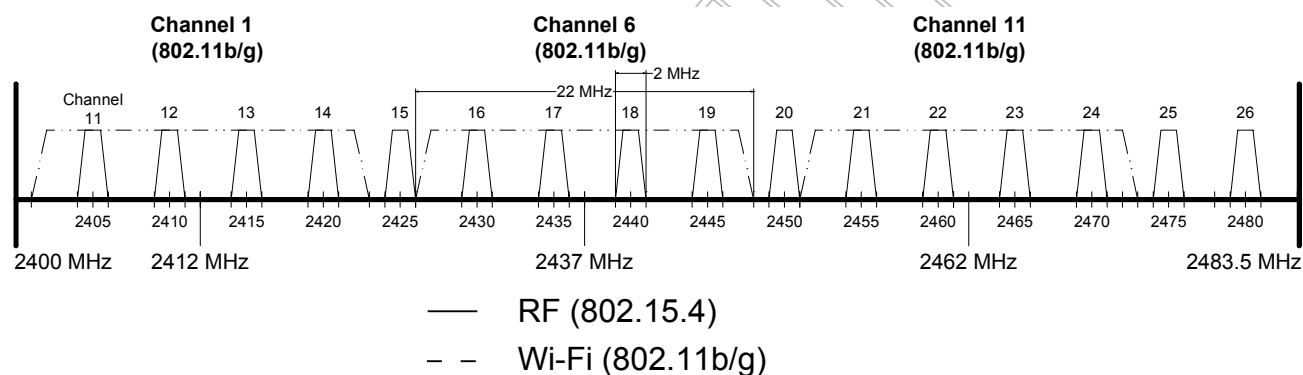

Appendix B: Optimum RF Reception Guidelines

Many factors can affect the reliability of RF communication between an RF gateway and an RF device. While an effort has been made to determine operating specifications, some specifications are not constant. RF Communication can be limited by several factors including but not limited to EMI (electromagnetic interference), intervening objects, antenna orientation and receiver placement. To obtain maximum reliability and performance, some basic rules for installing RF transceivers are listed below.

Minimize Interference

RF reception range can be hindered by spurious EMI noise that may interfere with or mask the desired frequency, thereby reducing useable range. EMI is generated by any electrical device at various RF noise levels depending on the device. Sources of EMI include computers, video equipment, digital processors, lighting dimmers, lighting ballasts, motors or any large AC source. Every effort should be made to separate any RF transceiver from these sources of RF noise including Audio Visual equipment in racks. If a gateway must be installed in an equipment rack, make sure you have ample separation between the equipment and the gateway.

Gateway Placement

Optimum reception for any RF transceiver is obtained by installing the gateway transceiver in an open area or shelf with a clear line of sight (no obstructions between gateway and receiver). Crestron recommends that the gateway is at least five to six feet high for best results. Avoid placing transceivers or transmitters at a low height or on the ground. Placing RF equipment near metal objects, walls, corners or metal enclosures will compromise RF propagation and reception. Try to avoid installing gateways in equipment racks, service rooms, electrical closets or in rooms other than that which the panel is located.

Antenna Orientation

The antenna orientation on Crestron gateways has considerable effect on range and reliability. The best orientation is unique to each installation. There are three possible antenna orientations:

- Point the antenna horizontally (parallel to the ground)
- Point the antenna vertically.
- Point the antenna at a right angle to the gateway.

Never point the antenna downward as this will decrease range and reliability. Refer to illustration below and those on the following page for examples of the different antenna orientations.

NOTE: RF propagation is best from the sides of the antenna.

Horizontal Orientation

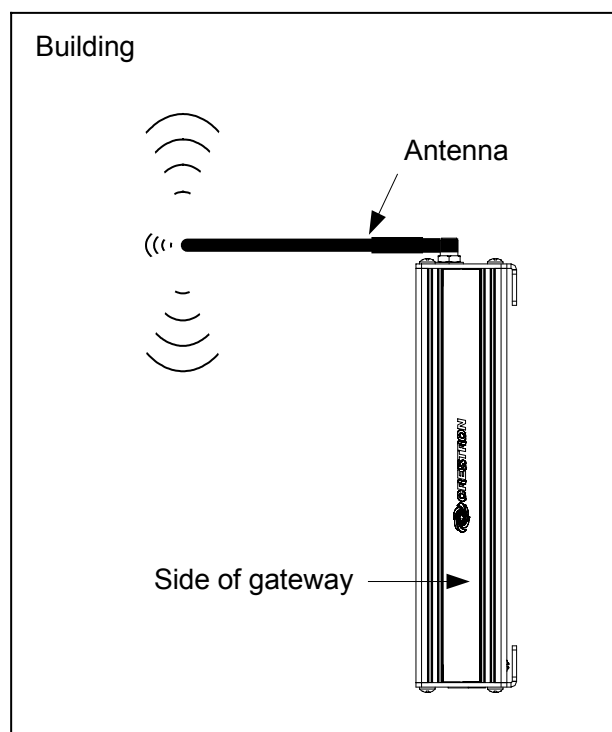

Vertical Orientation

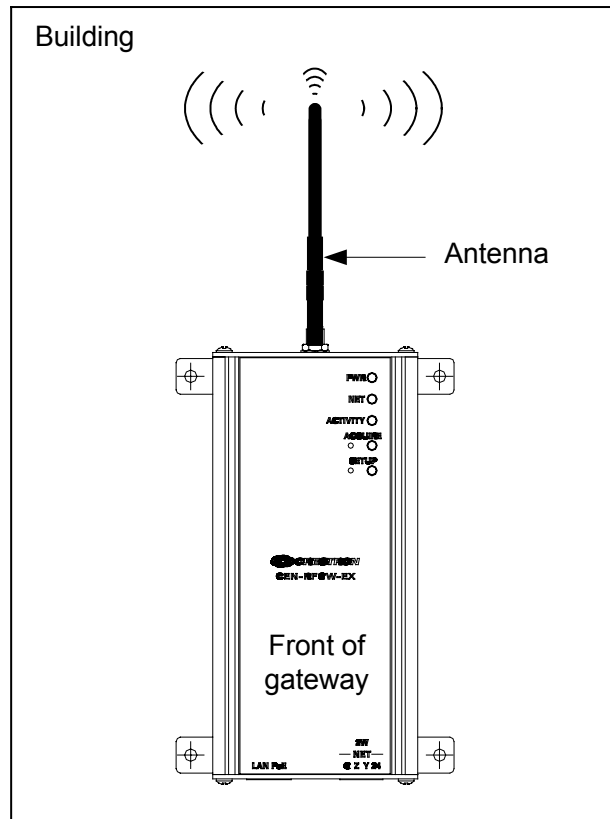

Right Angle Orientation

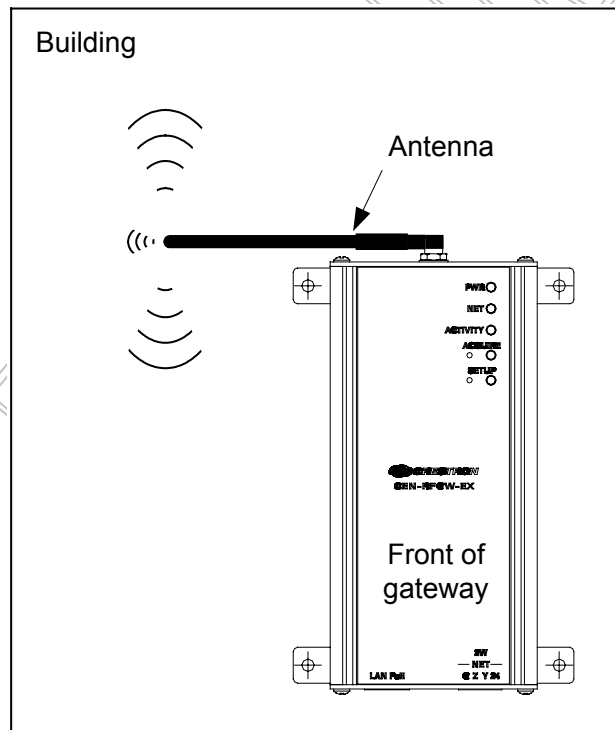

Return and Warranty Policies

Merchandise Returns / Repair Service

1. No merchandise may be returned for credit, exchange or service without prior authorization from CRESTRON. To obtain warranty service for CRESTRON products, contact an authorized CRESTRON dealer. Only authorized CRESTRON dealers may contact the factory and request an RMA (Return Merchandise Authorization) number. Enclose a note specifying the nature of the problem, name and phone number of contact person, RMA number and return address.
2. Products may be returned for credit, exchange or service with a CRESTRON Return Merchandise Authorization (RMA) number. Authorized returns must be shipped freight prepaid to CRESTRON, 6 Volvo Drive, Rockleigh, N.J. or its authorized subsidiaries, with RMA number clearly marked on the outside of all cartons. Shipments arriving freight collect or without an RMA number shall be subject to refusal. CRESTRON reserves the right in its sole and absolute discretion to charge a 15% restocking fee plus shipping costs on any products returned with an RMA.
3. Return freight charges following repair of items under warranty shall be paid by CRESTRON, shipping by standard ground carrier. In the event repairs are found to be non-warranty, return freight costs shall be paid by the purchaser.

CRESTRON Limited Warranty

CRESTRON ELECTRONICS, Inc. warrants its products to be free from manufacturing defects in materials and workmanship under normal use for a period of three (3) years from the date of purchase from CRESTRON, with the following exceptions: disk drives and any other moving or rotating mechanical parts, pan/tilt heads and power supplies are covered for a period of one (1) year; touchscreen display and overlay components are covered for 90 days; batteries and incandescent lamps are not covered.

This warranty extends to products purchased directly from CRESTRON or an authorized CRESTRON dealer. Purchasers should inquire of the dealer regarding the nature and extent of the dealer's warranty, if any.

CRESTRON shall not be liable to honor the terms of this warranty if the product has been used in any application other than that for which it was intended or if it has been subjected to misuse, accidental damage, modification or improper installation procedures. Furthermore, this warranty does not cover any product that has had the serial number altered, defaced or removed.

This warranty shall be the sole and exclusive remedy to the original purchaser. In no event shall CRESTRON be liable for incidental or consequential damages of any kind (property or economic damages inclusive) arising from the sale or use of this equipment. CRESTRON is not liable for any claim made by a third party or made by the purchaser for a third party.

CRESTRON shall, at its option, repair or replace any product found defective, without charge for parts or labor. Repaired or replaced equipment and parts supplied under this warranty shall be covered only by the unexpired portion of the warranty.

Except as expressly set forth in this warranty, CRESTRON makes no other warranties, expressed or implied, nor authorizes any other party to offer any warranty, including any implied warranties of merchantability or fitness for a particular purpose. Any implied warranties that may be imposed by law are limited to the terms of this limited warranty. This warranty statement supersedes all previous warranties.

Trademark Information

All brand names, product names and trademarks are the sole property of their respective owners. Windows is a registered trademark of Microsoft Corporation. Windows95/98/Me/XP/Vista and WindowsNT/2000 are trademarks of Microsoft Corporation.

PRELIMINARY

This page is intentionally left blank.

This page is intentionally left blank.

PRELIMINARY

PRELIMINARY

This page is intentionally left blank.

PRELIMINARY



Crestron Electronics, Inc.
15 Volvo Drive Rockleigh, NJ 07647
Tel: 888.CRESTRON
Fax: 201.767.7576
www.crestron.com

Operations & Installation Guide – DOC. 6706B
(2021630)

01.09

Specifications subject to
change without notice.