

Crestron **CWD7550**  
Two-Way RF Transceiver Module  

---

Operations Guide



**CRESTRON**

This document was prepared and written by the Technical Documentation department at:



Crestron Electronics, Inc.  
15 Volvo Drive  
Rockleigh, NJ 07647  
1-888-CRESTRON

## Regulatory Compliance

### Federal Communications Commission (FCC) Compliance Statement

This device complies with part 15 of the FCC Rules. Operation is subject to the following conditions:

(1) This device may not cause harmful interference and (2) this device must accept any interference received, including interference that may cause undesired operation.

**CAUTION:** Changes or modifications not expressly approved by the manufacturer responsible for compliance could void the user's authority to operate the equipment.

**NOTE:** This equipment has been tested and found to comply with the limits for a Class B device, pursuant to part 15 of the FCC Rules. These limits are designed to provide reasonable protection against harmful interference in a residential installation. This equipment generates, uses and can radiate radio frequency energy and if not installed and used in accordance with the instructions, may cause harmful interference to radio communications. However, there is no guarantee that interference will not occur in a particular installation. If this equipment does cause harmful interference to radio or television reception, which can be determined by turning the equipment off and on, the user is encouraged to try to correct the interference by one or more of the following measures:

- Reorient or relocate the receiving antenna
- Increase the separation between the equipment and receiver
- Connect the equipment into an outlet on a circuit different from that to which the receiver is connected
- Consult the dealer or an experienced radio/TV technician for help

### Industry Canada (IC) Compliance Statement

Operation is subject to the following two conditions:

1. This device may not cause interference, and
2. This device must accept any interference, including interference that may cause undesired operation of the device.

Le présent appareil est conforme aux CNR d'Industrie Canada applicables aux appareils radio exempts de licence. L'exploitation est autorisée aux deux conditions suivantes :

1. l'appareil ne doit pas produire de brouillage, et
2. l'utilisateur de l'appareil doit accepter tout brouillage radioélectrique subi, même si le brouillage est susceptible d'en compromettre le fonctionnement.

To satisfy RF exposure requirements, this device and its antenna must operate with a separation distance of at least 20 centimeters from all persons and must not be collocated or operating in conjunction with any other antenna or transmitter.

# Crestron **CWD7550**

## Two-Way RF Transceiver Module

---

## Operations Guide

All brand names, product names and trademarks are the property of their respective owners.  
©2010 Crestron Electronics, Inc.



# Contents

<b>Two-Way RF Transceiver Module: CWD7550 .....</b>	<b>1</b>
Functions and Features .....	1
Specifications.....	2
Physical Description .....	2
Setup .....	4
Labeling .....	4
Documentation.....	4



# Two-Way RF Transceiver Module: CWD7550

---

## Functions and Features

The CWD7550 (hereafter referred to as “module”) is a two-way radio frequency (RF) module that utilizes the 2.4 GHz frequency band to communicate with other devices.

The module operates according to the IEEE 802.15.4 specification and can be configured to minimize the possibility of interference with other devices.

The module receives RF signals from one or more Crestron devices and can transmit these signals over the air for further processing (depending on the application).

### Functional Summary

- 2.4 GHz frequency band, IEEE 802.15.4 specification
- Range from 3 feet to 500 ft.
- Operates on one of sixteen available channels to establish optimal signal quality

## Specifications

The table below is a summary of specifications for the CWD7550.

### *Specifications of the CWD7550*

SPECIFICATION	DETAILS
Power Requirements	1.34 Watts (5VDC @ 0.26A)
Operating Frequency	2400 MHz to 2483.5 MHz (802.15.4 compliant)
Operating Ranges <sup>1</sup>	
Minimum Distance	3 ft
Maximum Distance Indoors (without repeater device)	50 ft
Available Channels	16 (numbered 11 through 26 per 802.15.4)
RF Output Power	100mW
Dimensions	Width: 1.64 in (4.15 cm) Height: 2.35 in (5.98 cm) Depth: 0.66 in (1.68 cm)
Antenna	Antenna: Mica 2.4GHz SMD Antenna (A5645) Frequency Range: 2.4-2.5GHz Gain: 1.9 dBi max. Type: The antenna requires a groundplane, VSWR: 1.8:1 (max @ 1.8 dBi)

- The location and orientation of the module are important factors in the RF performance. With the unit located outside of any metal enclosures, the antenna is adjusted to achieve the best range. The range is dependent on its placement and the building in which it is used. The construction of the building, obstructions, and RF interference from other devices are factors determining the effective range of the unit. To prevent unit-to-unit RF interference, multiple modules operating at the same frequencies should not be installed within 3-5 feet of each other.

## Physical Description

The module, shown below, consists of various components attached to a printed circuit board.

There are three (2) different build options for this module. The options specify the number of installed push buttons/switches, the number and color of installed LEDs.

### *Physical View of CWD7550 (with 5 switches and 7 LEDs installed)*

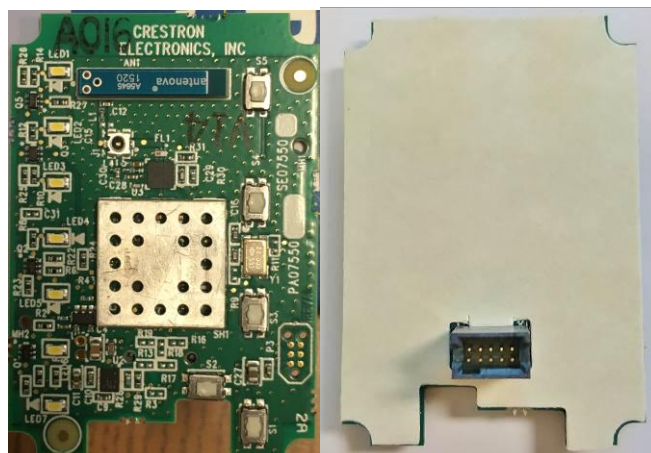



*CWD7550 Detail Views*

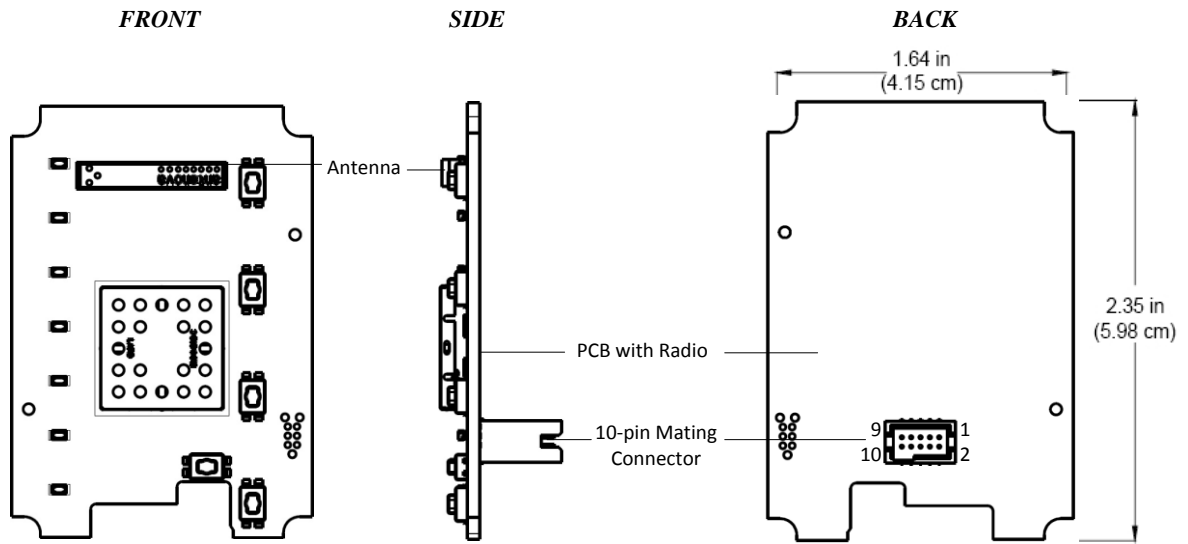

**Ports**

The module contains a 10-pin connector. Refer to the diagrams and descriptions that follow.

**Power/I-O**

The 10 pin connector provides power to the module as well as communications between the module and wired devices. Refer to the following table for pin assignments of the module interface connector.

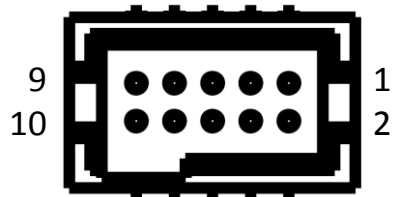

**NOTE:** Pin 1 provides power to the circuit card.

**Power/I-O Pinout Signals**

Pin #	Signal	Pin #	Signal
1	+5V	6	PWM
2	RELAY_ON	7	DISABLE_SINK
3	DISABLE_SOURCE	8	3.0V
4	RELAY_OFF	9	GND
5	ANALOG_FB	10	GND

---

## Setup

### *Hardware Hookup*

Refer to the hookup diagram below, which shows the connections made to the module. Complete the connections in any order.

**NOTE:** To prevent unit-to-unit RF interference, multiple modules operating at the same frequencies should not be installed within three to five feet of each other.

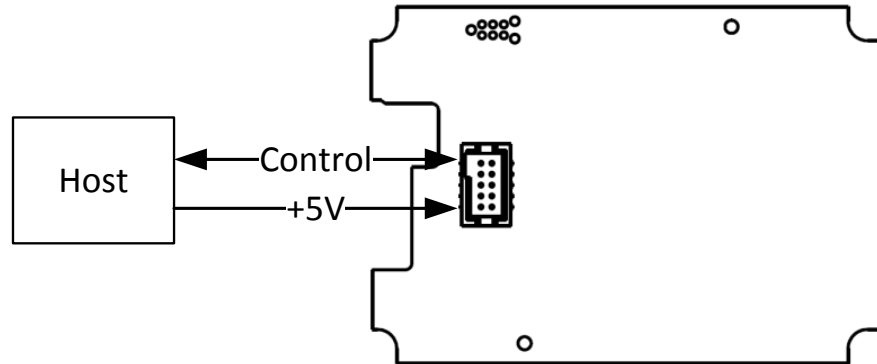

---

## Labeling

If the FCC identification number is not visible when the module is installed inside another device, then the outside of the device into which the module is installed must also display a label referring to the enclosed module. This exterior label can use wording such as the following: "Contains Transmitter Module FCC ID: EROCWD7550" or "Contains FCC ID: EROCWD7550." Any similar wording that expresses the same meaning may be used.

---

## Documentation

The OEM integrator has to be aware not to provide information to the end user regarding how to install or remove this RF module in the users manual of the end product.

The users manual for OEM integrators must include the following information in a prominent location

**“IMPORTANT NOTE:** To comply with FCC RF exposure compliance requirements, the antenna used for this transmitter must be installed to provide a separation distance of at least 20 cm from all persons and must not be co-located or operating in conjunction with any other antenna or transmitter.”

This page intentionally left blank



Crestron Electronics, Inc.  
15 Volvo Drive Rockleigh, NJ 07647  
Tel: 888.CRESTRON  
Fax: 201.767.7576  
[www.crestron.com](http://www.crestron.com)

Operations Guide – DOC. 7019A

**03.10**  
Specifications subject to  
change without notice.