

## GLS-LDL-EX-BATT

### Battery-Powered Photo Sensor with infiNET EX<sup>®</sup>, Dual-Loop Installation & Operation Guide



#### Description

The Crestron<sup>®</sup> GLS-LDL-EX-BATT is a battery-powered, wireless photo sensor designed for daylight harvesting applications to control the balance of natural and artificial lighting in an indoor space. Dual-loop sensing is achieved on the GLS-LDL-EX-BATT by two internal photocells—one for open-loop daylight sensing and one for closed-loop ambient light sensing.

#### Additional Resources

Visit the product page on the Crestron website ([www.crestron.com](http://www.crestron.com)) for additional information and the latest firmware updates.



#### Installation

##### NOTES: Observe the following points:

- This product must be installed and used in accordance with appropriate electrical codes and regulations.
- This product must be installed by a qualified electrician.
- Sensors must be mounted on a vibration-free surface.

The GLS-LDL-EX-BATT must be installed so that it faces a window. The device should be installed approximately 4 to 6 feet (1.22 to 1.83 meters) away from the window. The optimum viewing angle for the open loop sensor is 35°. The closed-loop viewing angle is straight down.

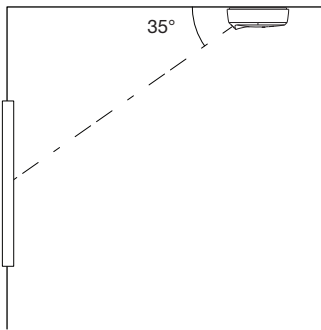

#### Insert the Batteries

Insert the batteries into the back of the GLS-LDL-EX-BATT. The orientation of the batteries is indicated on the device.

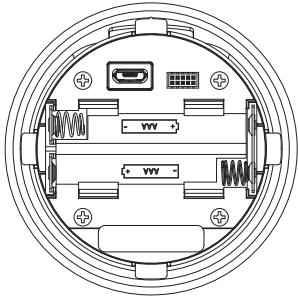

#### Mount the Base

When mounting the base, ensure that the arrow on the base, shown below, points toward the desired window.

Arrow must point toward window.

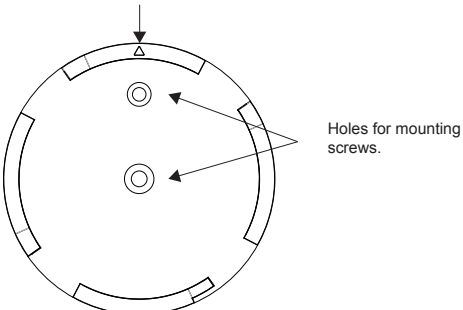

The base must be mounted to the drywall or drop ceiling using the provided anchors.

1. Determine the proper orientation for the GLS-LDL-EX-BATT.
2. Hold the base on the mounting surface, and use the holes for the mounting screws to mark the screw locations.
3. Using a 1/4 in drill bit, drill a pilot hole for the small anchor, and insert the small anchor into the pilot hole.
4. Using a #2 or #3 Phillips screwdriver, push the self-tapping anchor into the surface of the drywall until the cutting blades penetrate the surface. Using gentle forward pressure, rotate the anchor until the collar sets flush to the surface of the ceiling.
5. Secure the base to the mounting surface using two screws.

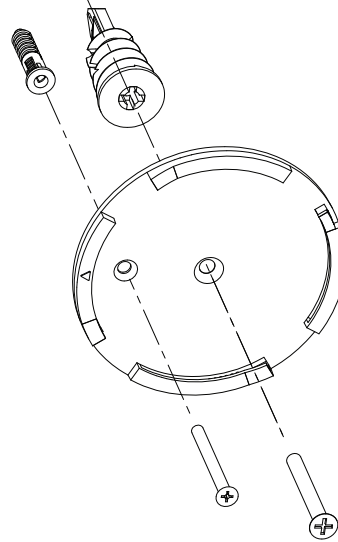

6. Place the sensor on the base and then rotate the sensor clockwise to secure it.

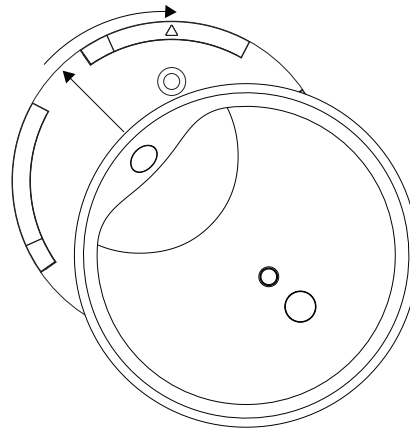

The sensor has the capability to rotate up to 40° along the base after it is mounted. Rotate the sensor so that it is perpendicular to the window.

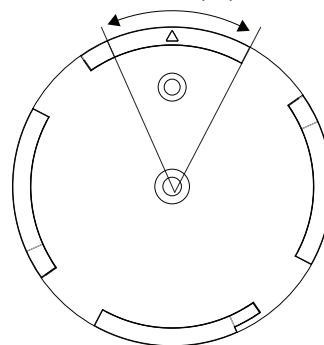

#### Configuration

The GLS-LDL-EX-BATT is set up and configured during system commissioning. Refer to the SIMPL Windows help file for details.

## Replace the Batteries

The battery should be replaced with a battery that is the same or better than the provided Energizer® L92 Ultimate Lithium AAA battery. Discard batteries appropriately after use.

## RF ID

It is recommended to have direct access to the GLS-LDL-EX-BATT and to use Crestron Toolbox™ to set the RF ID of the device. Set the RF ID for the GLS-LDL-EX-BATT by doing the following.

1. Wake the device by pressing the button on the GLS-LDL-EX-BATT.
2. Set the RF ID of the device using Crestron Toolbox. The RF ID must match the RF ID specified in the Crestron Studio or SIMPL Windows program.
3. Press the button on the GLS-LDL-EX-BATT to ensure that the device is still awake and the RF ID is transferred to the device.

The RF ID can also be set by putting the device into Setup mode.

1. Press the button for more than 4 seconds. The LEDs blink.
2. Set the RF ID using Crestron Toolbox. Setup mode exits after 5 minutes.

## Firmware Upgrade

**NOTE:** Before using the GLS-LDL-EX-BATT, ensure the device is using the latest firmware. Check for the latest firmware for the GLS-LDL-EX-BATT at [www.crestron.com/firmware](http://www.crestron.com/firmware). Firmware is loaded onto the device using Crestron Toolbox.

**NOTE:** Only one over-the-air firmware upgrade can be performed at a time.

To upgrade the firmware on the GLS-LDL-EX-BATT, follow the procedure below using Crestron Toolbox (v. 2.36.216 or later):

1. Select **Tools > Network Device Tree View**.
2. Right-click the GLS-LDL-EX-BATT in the **Network Device Tree View** window.
3. Select **Functions > Firmware Upload**.
4. Click the **Browse** button in the **Firmware Upload** window and browse for the firmware in the **Open** window.
5. Click the **Send** button to transfer the firmware.

**NOTE:** The firmware temporarily stays on the gateway until the GLS-LDL-EX-BATT initiates the firmware transfer.

6. Initiate the firmware transfer by pressing the button on the GLS-LDL-EX-BATT, waiting 5 seconds, and then pressing the button again.

**NOTE:** The LED on the GLS-LDL-EX-BATT will blink once every 1.5 seconds to indicate that the firmware is being transferred to the device. If the LED does not start blinking, repeat step 6.

7. Refresh the **Network Device Tree View** window to confirm that the firmware was transferred.

## Wireless Communications

The device connects to the Crestron network via the infiNET EX® communications protocol. Use the procedures outlined below to join or leave an infiNET EX network and to verify communications between the device and the control system.

### Joining an infiNET EX Network

Before a device can be used in a lighting system, it must first join an infiNET EX network. To join an infiNET EX network, the device must be acquired by an infiNET EX gateway.

**NOTE:** A device can be acquired by only one gateway.

1. Put the infiNET EX gateway into Acquire mode from the unit itself or from Crestron Toolbox. Refer to the gateway's manual at [www.crestron.com/manuals](http://www.crestron.com/manuals) for details.

**NOTE:** In an environment where multiple gateways are installed, only one gateway should be in Acquire mode at any time.

2. Put the device into Acquire mode by doing the following:
  - a. Tap the button three times and then press and hold it down (tap-tap-tap-press+hold) until the top LEDs on the device blink once (this can take up to 10 seconds).
  - b. Release the button to start the acquire process. The LED blinks slowly to show that the device is actively scanning the infiNET EX network.
    - The LED turns on for 5 seconds to show that the device has been successfully acquired by the infiNET EX network.
    - The LED blinks fast to indicate that the device was not successfully acquired by the infiNET EX network. Tap the top button to acknowledge the failure. The LEDs time out automatically. Ensure the gateway is in Acquire mode and within range before attempting the acquire process again.

### Leaving an infiNET EX Network

To leave an infiNET EX network, put the device into Acquire mode, as described in "Joining an infiNET EX Network" above, when no gateway is in Acquire mode.

### Verifying Communications Status

To check the communication status of the device, tap the button three times and then press and hold it down (tap-tap-tap-press+hold) for up to 2 seconds. The LED blinks to indicate the communications status. Refer to the following table for details.

LED	COMMUNICATIONS STATUS
Blinks three times	The device is communicating with the gateway.
Blinks twice	The device was previously joined to the network but is not communicating with the gateway.
Blinks once	The device is not joined to the network.

**NOTE:** Wireless networks composed predominantly of battery-powered devices may need additional infiNET EX expanders, such as the CLW-EXPEX or GLA-EXPEX (sold separately) or other non-battery powered infiNET EX devices, to ensure proper functionality of the network and battery life for the devices. Refer to the Best Practices for Installation and Setup of Crestron RF Products (Doc. 6689) at [www.crestron.com/manuals](http://www.crestron.com/manuals) for complete system design guidelines or contact Crestron True Blue Support for further assistance.

As of the date of manufacture, the GLS-LDL-EX-BATT has been tested and found to comply with specifications for CE marking.



### Federal Communications Commission (FCC) Compliance Statement

This device complies with part 15 of the FCC Rules. Operation is subject to the following conditions:

(1) This device may not cause harmful interference and (2) this device must accept any interference received, including interference that may cause undesired operation.

**CAUTION:** Changes or modifications not expressly approved by the manufacturer responsible for compliance could void the user's authority to operate the equipment.

**NOTE:** This equipment has been tested and found to comply with the limits for a Class B digital device, pursuant to part 15 of the FCC Rules. These limits are designed to provide reasonable protection against harmful interference in a residential installation. This equipment generates, uses and can radiate radio frequency energy and, if not installed and used in accordance with the instructions, may cause harmful interference to radio communications. However, there is no guarantee that interference will not occur in a particular installation. If this equipment does cause harmful interference to radio or television reception, which can be determined by turning the equipment off and on, the user is encouraged to try to correct the interference by one or more of the following measures:

- Reorient or relocate the receiving antenna
- Increase the separation between the equipment and receiver
- Connect the equipment into an outlet on a circuit different from that to which the receiver is connected
- Consult the dealer or an experienced radio/TV technician for help

### Industry Canada (IC) Compliance Statement

This device complies with Industry Canada license-exempt RSS standard(s). Operation is subject to the following two conditions: (1) this device may not cause interference and (2) this device must accept any interference, including interference that may cause undesired operation of the device.

Under Industry Canada regulations, this radio transmitter may only operate using an antenna of a type and maximum (or lesser) gain approved for the transmitter by Industry Canada. To reduce potential radio interference to other users, the antenna type and its gain should be so chosen that the equivalent isotropically radiated power (e.i.r.p.) is not more than that necessary for successful communication.

### Industrie Canada (IC) Déclaration de conformité

Le présent appareil est conforme aux CNR d'Industrie Canada applicables aux appareils radio exempts de licence. L'exploitation est autorisée aux deux conditions suivantes: (1) l'appareil ne doit pas produire de brouillage, et (2) l'utilisateur de l'appareil doit accepter tout brouillage radioélectrique subi, même si le brouillage est susceptible d'en compromettre le fonctionnement.

Conformément à la réglementation d'Industrie Canada, le présent émetteur radio peut fonctionner avec une antenne d'un type et d'un gain maximal (ou inférieur) approuvé pour l'émetteur par Industrie Canada. Dans le but de réduire les risques de brouillage radioélectrique à l'intention des autres utilisateurs, il faut choisir le type d'antenne et son gain de sorte que la puissance isotrope rayonnée équivalente (p.i.r.e.) ne dépasse pas l'intensité nécessaire à l'établissement d'une communication satisfaisante.

To satisfy RF exposure requirements, this device and its antenna must operate with a separation distance of at least 20 centimeters from all persons and must not be collocated or operating in conjunction with any other antenna or transmitter.

The product warranty can be found at [www.crestron.com/warranty](http://www.crestron.com/warranty).

The specific patents that cover Crestron products are listed at [patents.crestron.com](http://patents.crestron.com).

Crestron, the Crestron logo, Crestron Toolbox, and infiNET EX are either trademarks or registered trademarks of Crestron Electronics, Inc. in the United States and/or other countries. Energizer is a trademark or registered trademark of Energizer Battery Company, Inc. Other trademarks, registered trademarks, and trade names may be used in this document to refer to either the entities claiming the marks and names or their products. Crestron disclaims any proprietary interest in the marks and names of others. Crestron is not responsible for errors in typography or photography.

This document was written by the Technical Publications department at Crestron.

©2015 Crestron Electronics, Inc.

Crestron Electronics, Inc.  
15 Volvo Drive Rockleigh, NJ 07647  
Tel: 888.CRESTRON  
Fax: 201.767.7576  
[www.crestron.com](http://www.crestron.com)

Installation & Operation Guide - DOC. 7554A  
(2043706)  
06.15

Specifications subject to  
change without notice.