



CHORD MS 530

Wireless Headphones with Active Noise Cancelling

Owner's guide / Guide de l'utilisateur / Guía para el usuario /
Bedienungsanleitung / 사용자 안내서 / オーナーズガイド / 用户指南

WIRELESS HEADPHONES with ACTIVE NOISE CANCELLING

Thank you for purchasing PHIATON® MS 530

- Please check all of the warnings and notices in the owner's guide before using the product.
- Please follow the directions, and read the guidelines carefully before use.
(Please, keep the owner's guide for your future reference.)
- Some functions of MS 530 may not be available when the MS 530 is paired with certain devices.

1. SAFTY AND GENERAL INFORMATION

- 1) Use a standard USB charging cable (included), with or without a charging adaptor (5V, over 500mA).
- 2) Lower the volume prior to listening to audio to prevent potential damage to eardrums caused by sudden loud sound.
- 3) Listening to loud music for extended periods of time may cause hearing damage.
- 4) Do not store the device in places with a temperature higher than 113 Degrees F / 45 degrees C.
- 5) Keep the device dry.
If the device becomes wet, turn the power off, dry the device with a dry towel and contact Phiaton Customer Service for an inspection(For more information, refer to the contact us page within our website – phiaton.com).
- 6) Do not attempt to disassemble, modify or repair the device.
- 7) Do not cause shock to the device.
- 8) Keep out of the reach of children and pets.
- 9) Do not tug on cords or touch power plugs with wet hands.
- 10) Do not use the device nearby microwave ovens or wireless LAN adaptors.
- 11) When the product is not being used, set the device power switch to 'OFF'.
- 12) When storing the headphones, place the device within the provided pouch.

13) When cleaning the headphones, use a clean dry cloth to wipe the device clean.

(Do not use solvents).

14) When storing the headphones, the ear pads may become damaged due to sweat, moisture and makeup on the ear pads. Use a slightly wet towel or tissue and wipe the device before storing..

15) If your ear pads have been used for too long, replacement ear pads can be purchased from Phiaton Customer Service.

16) Use while driving or walking will prevent outside noise, such as signals or alarms, from being heard and may be dangerous to yourself and others. Heed caution during use.

* Use the headphones only for its intended purposes.

* This device cannot be used for purposes related to human safety as it may cause radio interference during operation.

2. PACKAGING COMPONENTS



CHORD MS 530

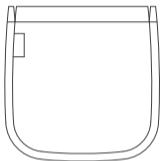

Carring Case



Warranty Card



Owner's Guide

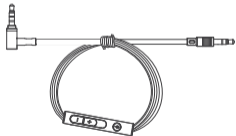

Mic Cable

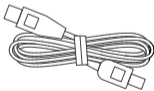

Mini USB Cable



Airport Adaptor

3. PRODUCT FEATURES

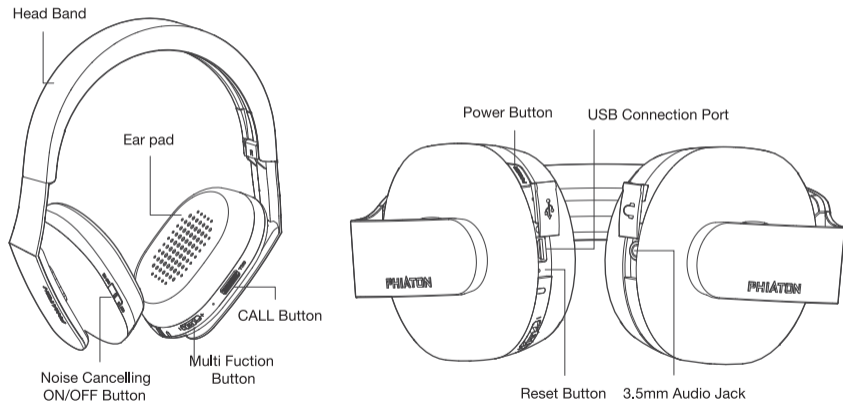

4. WEARING AND STORING HEADPHONES

1) As shown in the figure, adjust the band length to comfortable fit on your head.

(The R and L displayed on the inner-side of the headphones indicate the Right and Left positions.)

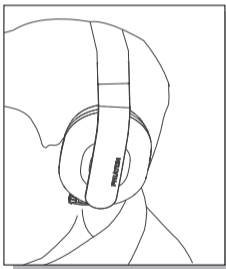
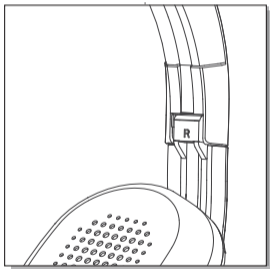

2) As shown in the figure, fold the headphones and place within the provided pouch for storage.

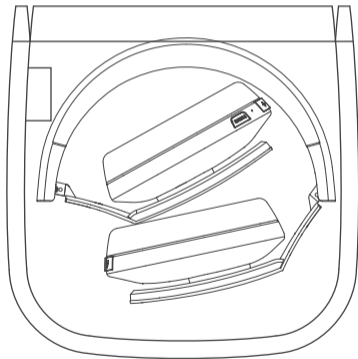

5. CHARGING

The device is not charged upon purchase and must first be charged before use.

- 1) Open the USB cover  on the headphone (CHORD MS 530) and connect the provided USB charging cable.
 - 2) Connect the provided USB charging cable with a computer (laptop) or you may also use a separately purchased USB adaptor (rating: 5V/over 500mA) to begin charging.
- This device is equipped with a battery and will automatically charge once a charging cable is connected.

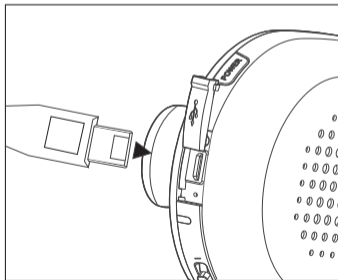

State	LED Indicator
Charging	Red light
Charging complete	Blue light

※ Battery use time



Noise Cancelling	Continuous Talk Time	Continuous Music Play Time	Continuous Wait Time
OFF	Max 29 hours	Max 30 hours	Max 980 hours
ON	Max 17 hours	Max 18 hours	Max 49 hours

- Full Charge Time: 2.5 hours

※ The above times may differ depending on the environment in which it is used.

6. POWER ON/OFF AND HEADPHONE CONNECTION WAIT MODE

1) Power ON/OFF

- Press and hold the POWER button  for two seconds to turn the power on.
- When turning the power off, press and hold the POWER button  for three seconds to turn off.

State	Operation	LED Indicator	Voice Guidance
ON	Press and hold the power button for 2 seconds	Blue light turns on for 1 second	POWER ON
OFF	Press and hold the power button for 3 seconds	Red light blinks 5 times	POWER OFF

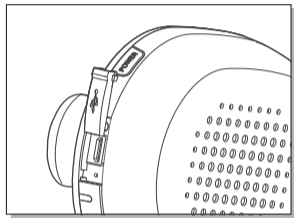

※ Upon purchasing the product, pairing mode will start once the power is turned on for the first time.

2) Connection Waiting Mode

- When power is turned on, 'Connection Waiting mode' will start if 'Pairing Mode' cannot be entered or the headphones cannot connect with 'Bluetooth device'.
- If the 'Bluetooth' device is not connected within 5 minutes in Connection Waiting Mode, the headphones will be automatically turned off.

State	LED Indicator
Connection Waiting Mode	Blue light blinks twice in 6 second intervals

7. PAIRING WITH A 'BLUETOOTH DEVICE'

1) Pairing

- Turn on the Bluetooth feature with the 'Bluetooth Device' you want to connect with the headphones.
- Place the headphones within 3 feet of the 'Bluetooth Device' you want to connect.
- Press and hold the CALL button  for over 3 seconds with the headphone power on to enter

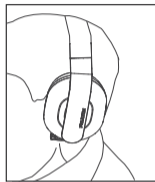

Operation	LED Indicator	Voice Guidance
Pairing Mode	Blue and red light alternately blinks	Pairing Mode Activated

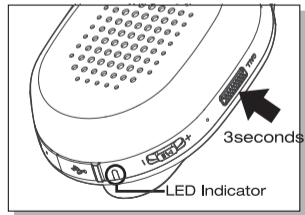

- Within the 'Bluetooth Device' you want to connect, search/select 'CHORD MS 530'.

※ If the "Bluetooth device" requires a PIN CODE or password enter '0000'.

- Play music or connect a call with the headphones, check the connection.

Operation	LED Indicator	Voice Guidance
Connection Successful	Purple light blinks twice	Device Connected

2) Re-connecting a Disconnected Device



① Auto Connection

- Once the device has been paired with a Bluetooth device, it will automatically be connected to a previously connected device once the headphone power is turned on.

If Bluetooth becomes disconnected as the discover range between the Bluetooth device and the headphones is exceeded, then Bluetooth will not be automatically re-connected.

When you are back within the discover range (30 feet), you must then connect manually.

② Manual Connection - When having entered 'Connection Waiting Mode' during connection

- Press the CALL button  or the Multifunction button  on the headphone to connect. The headphone will also be connected if you select 'CHORD MS 530' from the device search list within your 'Bluetooth Device'.

3) Checkpoints upon Pairing

- Check to see whether the Bluetooth feature is activated within the 'Bluetooth Device' you want to connect.

- When selecting the connection device, connect by selecting stereo headset device.
Music cannot be played when connected through mono headset.

※ In order to properly use the Bluetooth feature of this headset, the profile (A2DP, HSP, HFP and AVRCP) of the 'Bluetooth Device' you are trying to connect must support the profile of this headphone.

* A2DP – “Advanced Audio Distribution Profile”, HSP – “Headset Profile”, HFP – “Handsfree Profile”, AVRCP – “ Audio/Video Remote Control Profile”

The headphones will not operate properly if the profiles are not supported equally. Even when the profiles are supported equally, some features may not properly operate depending on the 'Bluetooth device's specifications. To check the detail specifications of this headphone's profile, refer to '15 - Product Specifications'.

8. MULTI-POINT CONNECTION

1) What is 'Multi-Point Connection'?

This is a feature where the headphone user can simultaneously connect two 'Bluetooth devices'.

2) Multi-Point Connecting

- Turn on the Bluetooth feature within the two 'Bluetooth Devices' you want to connect with the headphones
- Refer to '7-Pairing' to pair the first device with the headphones
- Press and hold the CALL button  again to enter Pairing Mode (Here, the first device becomes disconnected).
- Once 'Pairing Mode' has been entered, pair the second device.
- Re-connect the first device. Now, both of the devices will remain connected.

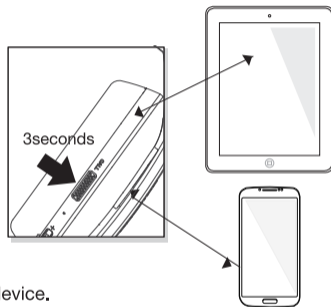



-
- ※ Sleep Mode will be entered when devices are not connected within two minutes. When trying to connect a device while in Sleep Mode, pressing any button will re-enter Connection Waiting Mode where connection is possible.
 - ※ When the headphone power is turned off and back on, only the second paired device will automatically be connected. When the first paired device is reconnected, then both of the devices will remain connected.

3) What is 'Auto Mode'?

This is a mode used to automatically re-connect both previously connected 'Bluetooth Devices' when the power is turned off and back on.

4) Using Auto Mode

- Within Pairing Mode, push the Multifunction button  in (+) direction for 3 seconds to turn on Auto Mode.
- If you push the Multifunction button  in (+) direction for 3 seconds again, then Auto Mode will turn off and switch to Manual Mode.

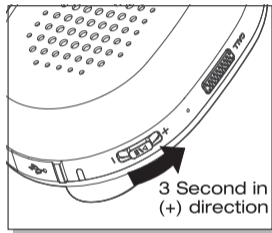

Operation	Voice Guidance
Auto Mode	On
Manual Mode	Off

-
- ※ Upon Multi-Point Connection, the features operated within the headphones usually operate within the second paired device (when using the first paired device, it is possible to operate the device from the headphone).
 - ※ When using multi-point connecting, the order of the paired devices may change. To change the order, re-connect the device you usually use.

 - ※ In order to properly use the Bluetooth feature of this headset, the profile (A2DP, HSP, HFP and AVRCP) of the 'Bluetooth Device' you are trying to connect must support the profile of this headphone.
 - * A2DP – “Advanced Audio Distribution Profile”, HSP – “Headset Profile”, HFP – “Handsfree Profile”, AVRCP – “ Audio/Video Remote Control Profile”

The headphones will not operate properly if the profiles are not supported equally. Even when the profiles are supported equally, some features may not properly operate depending on the 'Bluetooth device's specifications. To check the detail specifications of this headphone's profile, refer to '15 - Product Specifications'.

9. USING NOISE CANCELLING FEATURE

1) What is Noise Cancelling?

Noise Cancelling refers to a technology that reduces noise from mid/low pitched sounds under 1kHz.

2) Turning Noise Cancelling Feature On/Off

- Pushing the NC button  towards (ON) direction will turn Noise Cancelling ON while pushing the button towards (OFF) will discontinue Noise Cancelling.

Operation	NC Indicator (LED)
Noise Cancelling ON	Green light turns on

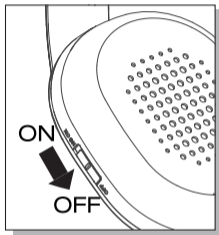



3) Cautions upon using Noise Cancelling feature

- Noise Cancelling cannot be used when the the battery is completely drained.
- Use while driving or walking will prevent outside noise, such as signals or alarms, from being heard and may be dangerous to yourself and others. Heed caution during use.
- Noise Cancelling is optimized for mechanical noises from airplanes, buses, and subway trains and is not required for use within quiet interior environments.

10. LISTENING TO MUSIC (PLAY & CONTROL)

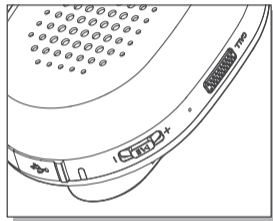

1) Playing Music

- Shortly press the Multifunction button  music from the 'Bluetooth Device'.
- While music is playing, shortly press the Multifunction button  to pause the playing music. The music will be played from the paused point when playing music again.
- While music is playing, pressing and holding the Multifunction button  for one second will stop the playing music. The music will be played from the start when playing music again.



※ The Stop function may not be supported depending on your 'Bluetooth Device'.

2) Controlling Volume and Using Seek

- Push the Multifunction button  in '+ / -' directions to control the volume.
- Push and hold the Multifunction button  in '+ / -' directions for about one second to go to the next / previous song.
- Push and hold the Multifunction button  in '+ / -' directions to fast-forward / rewind the current song

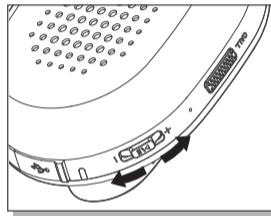



Operation	LED Indicator
While music is playing	Blue Light slowly blinks every 6 seconds

- * Music can be listened to through the headphones by directly operating your 'Bluetooth device'.
- * When the battery is completely drained, you can connect the provided audio cable to continue listening.

11. ACCEPTING / MAKING A CALL WHILE PLAYING MUSIC

1) Accepting a Call while Playing Music

- When the incoming call tone is heard through the headphones, press the CALL button.  The music will be paused and the call is connected.
- Once the call has ended, press the CALL button  to terminate the call. Once the call is terminated, the paused music will play again.

2) Making a Call while Playing Music

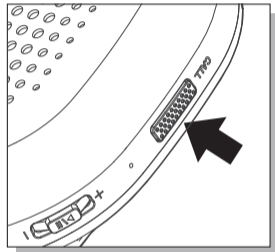

- While playing music, press and hold the CALL button  for about 1 second to pause the music and connect with the most recent number.



※ This feature may slightly differ depending on your 'Bluetooth Device'.

12. USING THE CALL FUNCTION

1) Accepting a Call

- When the incoming call tone is heard through the headphones, press the CALL button  (Adjusting Call Volume: to control the call volume, push the Multifunction button  in '+ / -' directions).

2) Ending a Call

- While on a call, shortly pressing the CALL button  to end the call.

3) Rejecting a Call

- When the incoming call tone is heard through the headphones, press and hold the CALL button  for about 1 second. (The 'Call Ignored' voice guidance is provided and the incoming call is rejected).

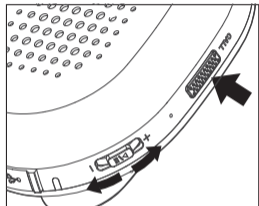

4) Turning Mute On/Off



- While on a call, push the Multifunction button  in '-' direction for about 1 second to mute sound. To turn back on, push the button again in '-' direction for about 1 second.

5) Making a Call

- Press and hold the CALL button  for about 1 second. The 'Redialing' voice guidance is provided and a call is connected with the most recent number.

※This feature may slightly differ depending on your 'Bluetooth Device'.

6) **Call Waiting (supported only when having applied for this service with your telecom provider). / When there is another incoming call while on a call.**

- Press and hold the CALL button  for about 1 second to place the current call on call waiting and connect the second call (Press the CALL button  again for about 1 second to switch between the waiting call and connected call).
- Shortly press the CALL button  to end the current call and connect the second call.

7) **Calling by Voice (supported within mobile phones that support the voice command feature).**

- While waiting or listening music, shortly press the CALL button .

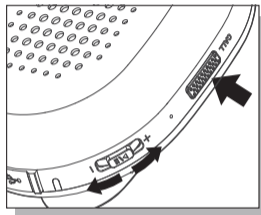

8) Switching between the Device and Mobile Phone

- To switch the call from mobile phone to the headphone, shortly press the CALL button twice.

Operation	LED Indicator
Incoming Bell/Outgoing Bell	Purple light blinks in 1.5 second intervals
During Call	Blue light slowly blinks every 6 seconds
When there are two calls connected	Purple light slowly blinks every 6 seconds

13. MISCELLANEOUS FEATURES

1) Checking Remaining Battery

- With the power on, shortly press the Power button  twice to display the remaining battery indicator (LED).
- For Apple iOS version 5 or above, the remaining battery is displayed at the top right side of the screen.

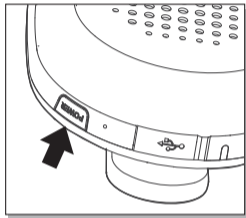

Remaining Battery	LED Indicator	Voice Guidance
Over 80%	Blue light lights up for 1 second	Battery is full
80% ~ 30%	Purple light lights up for 1 second	Battery is moderate
Under 30%	Red light lights up for 1 second	Battery is Low
Under 3%	Red light lights up for 1 second and the alarm will sound	Please Recharge



- * The Battery Check feature will not operate while the battery is being charged.
- * When the battery charge is under 3%, the alarm will sound. If use is continued for several minutes the battery will be completely drained, the 'Power Off' voice guidance is provided and the power will automatically turn off.

* When the battery is completely drained, the 'Power Off' voice guidance is provided and the power will automatically turn off

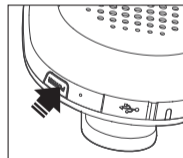
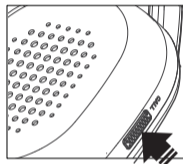

2) Activating/Deactivating the LED Indicator

- This headphone is equipped with an indicator that shows operating features to provide information on operating states.
- While pressing the CALL button , push the Multifunction button  in '-' direction for about 3 seconds to deactivate the indicator (LED) that shows operating states. To activate again, push the Multifunction button in '-' direction for about 3 seconds while pressing the CALL button.



Operation	LED Indicator	Voice Guidance
Activate	LED Display	<ul style="list-style-type: none"> - The 'LED Activated' voice guidance is provided. - Only the '●●↗' signal alarm is provided once through the headphone during a call, while playing music and after a call is ended/connected. .
Deactivate	Blank	<ul style="list-style-type: none"> - The 'LED Deactivated' voice guidance is provided. - Only the '●●↘' signal alarm is provided once through the headphone during a call, while playing music and after a call is ended/connected.

3) Enabling/Disabling Voice Guidance

- Within 'Pairing Mode', pressing the Multifunction button  for about 3 seconds will enable voice guidance and provide guidance when starting various features via voice (this feature may not be supported immediately after ending/connecting a call).
- Within 'Pairing Mode', again pressing the Multifunction button  for about 3 seconds will disable voice guidance.

Operation	Voice Guidance
Voice Guidance Activation	Voice Prompt Activated
Voice Guidance Deactivation	Voice Prompt Deactivated

- * Upon factory shipment, the voice guidance feature is enabled by default.
- * Once the voice guidance feature is disabled, the following signal tones are provided in place of voice guidance.

Operation	Voice Guidance
Power On/Off	●●●● ↗ / ●●●● ↘
Pairing Mode	●●●● →(Fast)'
Connection/Disconnection	●● →/●●●● ↘
Multipoint Connection Auto Mode On/Off	●- ↗ / ●- ↘
LED Indicator Activated/Deactivated	●- ↗ / ●- ↘
Redialing	●-
Incoming Call rejected	●- ●
Mute On/Off	●● ↗ / ●● ↘

4) Resetting the Device

- To reset to factory settings, push the Call and Play button  for 5 seconds simultaneously while in the Pairing Mode.

Operation	State
Pairing Information	Initialization
Voice Guidance	ON
Multi Point Connection Auto Mode	OFF
LED Indicator	ON

14. CONNECTING AND USING THE CABLE

- 1) This headphone can also be used with the cable connected as shown in the figure.

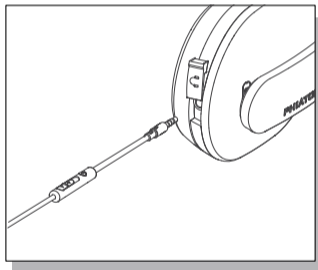

- 2) Even when using with a cable connected, the microphone and most other features will operate.

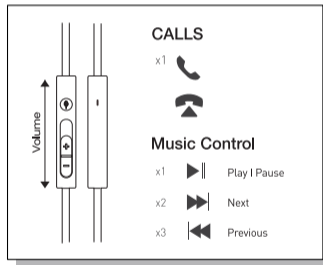

※ When connected due to battery discharge, only the music and phone features are supported.

15. SPECIFICATIONS

- Driver Unit : Φ 40 mm Driver Units
- Sensitivity: 100 dB
- Frequency Response: 15 Hz ~ 25 kHz
- Impedance: 32 Ω
- Max. Input Power: 1,000 mW
- Cable Length: 1.5 m
- Weight: 0.64 lb / 290 g (without Cable)
- Output Power: Power Class 2
- Max. Communication Range: Discoverable within 10 m
- Full Charging Time: 2.5 Hours
- Call Time (NC on / off): 17 Hours / 29 Hours
- Music Play Time (NC on / off): 18 Hours / 30 Hours
- Standby Time (NC on / off): 49 Hours / 980 Hours
- Operating Frequency: 2.4 GHz (2.402GHz ~ 2.480GHz)
- Bluetooth Profile Support: HFP v1.6 / HSP v1.1 / A2DP v1.2 / AVRCP v1.6

-
- Audio Codec : SBC, APT-X®
 - Battery : Lithium Polymer DC 3.7V / 520 mA
 - Microphone Frequency Range: 10 ~ 4,000Hz
 - Microphone Sensitivity: -42 dB
 - Support Echo Cancellation and Talk Noise: CVC Solution
 - Operating Temperature: 5 ~ 45°C

* The Specifications are subject to change without prior notice for quality improvement.

16. PRODUCT SYMPTOMS AND TROUBLESHOOTING

Problems	Solutions
The power does not	<ul style="list-style-type: none">- Charge the device. If the power does not turn on even after charging, contact Phiaton Customer Service.
The device does not charge:	<ul style="list-style-type: none">- Check whether the USB charging cable has been properly connected with the device.- Check whether the PC power is on and that it has been properly connected.- When using a separately purchased USB AC adaptor, check to see that it has been properly connected.
The devices does not pair	<ul style="list-style-type: none">- Check whether the power of the 'Bluetooth Device' you want to connect is on.- Check whether the Bluetooth feature within the 'Bluetooth Device' you want to connect is enabled.- Check whether the 'Bluetooth Device' you want to connect is within the supported range. (Pairing is supported only when within 3 ft.).- Check whether the Bluetooth profile within the 'Bluetooth Device' is compatible..
Music cannot be played	<ul style="list-style-type: none">- Check whether the power of the device and 'Bluetooth Device' is on- Check whether music is being played within the connected 'Bluetooth Device'.- Check whether the volume within the connected 'Bluetooth Device' is low.- When using an extension cord, check to see that the plug is properly connected.

Noise is heard or the sound lags	<ul style="list-style-type: none"> - Check whether there is an electronic device using the 2.4GHz frequency band nearby the device and connected 'Bluetooth Device'.. - Check whether the connected 'Bluetooth Device' is far away from this device. (max communication range: within 30 feet)
The music sound quality is low	<ul style="list-style-type: none"> - If the 'Bluetooth Device' you are trying to connect with this device is accessed to HSP, change the access to A2DP.
The other party cannot be heard while on a call	<ul style="list-style-type: none"> - Check whether the power of the 'Bluetooth Device' you want to connect is on. - Access Bluetooth through HFP or HSP. - Check whether the volume within the connected 'Bluetooth Device' is low.
Outside noise is too high or not reduced:	<ul style="list-style-type: none"> - Check whether Noise Cancelling is turned On. - Check whether the headphones are worn properly. (Noise will not be properly reduced if the ear pads are not properly worn on the ears).

<p>The LED Indicator does not operate</p>	<ul style="list-style-type: none">- Check whether the LED Indicator feature has been activated. (The LED Indicator feature can be activated by simultaneously pressing the CALL button and Multifunction Button for 1 second.)
<p>Product does not operate or operation has stopped</p>	<ul style="list-style-type: none">- Open the USB cover and use a pin to press the Reset hole located on the side of the USB connector.- Power will turn off once the Reset button is pressed.- Pairing information is not deleted even when the device is reset.

17. FCC compliance Information

FCC ID :

This device complies with part 15 of FCC Rules. Operation is subject to the following two conditions: (1) This device may not cause harmful interference. And (2) this device must accept any interference Received, including interference that may cause undesired operation.

Information to the user

NOTE: This equipment has been tested and found to comply with limits for a Class B digital device, Pursuant to part 15 of the FCC Rules. These limits are designed to provide reasonable protection against Harmful interference in a residential installation. This equipment generates, use and can radiate radio Frequency energy and, if not installed and used in accordance with the instructions, may cause harmful Interference to radio communications. However, there is no guarantee that interference will not occur in a Particular installation. If this equipment does cause harmful interference to radio or television reception, Which can be determined by turning the equipment off and on, the user is encouraged to try to the correct the Interference by one or more of the following measures:

- Reorient or relocate the receiving antenna.
- Increase the separation between the equipment and receiver.
- Connect the equipment into an outlet on a circuit different from that to which the receiver is connected.
- Consult the dealer or an experienced radio/TV technician for help.

CAUTION TO USER: Changes or modifications not expressly approved by the party responsible for compliance could void the user's authority to operate the equipment.

18. IC compliance Information

This device complies with Industry Canada licence-exempt RSS standard(s).

Operation is subject to the following two conditions:

(1) this device may not cause interference, and (2) this device must accept any interference, including interference that may cause undesired operation of the device.

This equipment complies with IC radiation exposure limits set forth for an uncontrolled environment and meets RSS-102 of the IC radio frequency (RF) Exposure rules.

This equipment has very low levels of RF energy that are deemed to comply without testing of specific absorption ratio (SAR).