

Wireless

sensor networks

MPR/ MIB User's Manual

Rev. A, August 2004

Document 7430-0021-06

Crossbow

Crossbow Technology, Inc. 41 Daggett Dr., San Jose, CA 95134

Tel: 408.965.3300, Fax: 408.324.4840

Email: info@xbow.com, Website: www.xbow.com

© 2002-2004 Crossbow Technology, Inc. All rights reserved.
Information in this document is subject to change without notice.

Crossbow is a registered trademark. DMU is a trademark of Crossbow Technology, Inc. Other product and trade names are trademarks or registered trademarks of their respective holders.

Table of Contents

1	Introduction	3
2	MPR2400 (MICAz)	4
2.1	Product Summary	4
2.2	Block Diagram and Schematics for the MPR2400 / MICAz	4
2.3	FCC Certification for the MICAz	8
3	MPR400/MPR410/MPR420 (MICA2)	9
3.1	Product Summary	9
3.2	Block Diagram and Schematics: MPR400/410/420	9
4	MPR500/MPR510/MPR520 (MICA2DOT)	14
4.1	Product Summary	14
4.2	On-board Thermistor	14
4.3	Block Diagram and Schematics for the MPR500/510/520 MICA2DOT	15
5	MPR300/MPR310 (MICA)	19
5.1	Schematic	19
	Power	20
6	20	
6.1	Battery Power	20
6.2	External Power	21
6.3	MICAz Battery Voltage Monitor	22
6.4	MICA2 Battery Voltage Monitor	22
6.5	MICA2DOT Battery Voltage Monitor	23
7	Radios	24
7.1	MICA2 and MICA2DOT	24
7.2	MICAz	26
8	Antennas	29
8.1	Radio/Antenna Considerations	29
8.2	Connectors for the MICA2 and MICAz and Whip Antennas	29
9	Flash Data Logger and Serial ID Chip	31
10	Atmega128 Fuses	32
11	Sensor Boards & Expansion Connectors	33
11.1	Sensor Board Compatibility	33
11.2	MICAz and MICA2 Expansion Connector	33
11.3	MICA2DOT Expansion Connector	35
12	MIB300 / MIB500 Interface Boards	36



12.1	Programming the Mote	36
12.2	RS-232 Interface	36
13	MIB510 Serial Interface Boards	37
13.1	Product Summary	37
13.2	ISP	37
13.3	Mote Programming Using the MIB510	37
13.4	Interfaces to MICAz, MICA2, and MICA2DOT	38
14	MIB600CA	42
14.1	Introduction	42
14.2	Setup / Installation	42
	Host Software.....	44
14.3	44	
14.4	MIB600 Use.....	44
	JTAG.....	45
14.5	45	
15	Appendix A: 10/100 Base-T Cabling Standards	47
16	Warranty and Support Information.....	48
16.1	Customer Service	48
16.2	Contact Directory	48
16.3	Return Procedure.....	48
16.4	Warranty.....	49

1 INTRODUCTION

This *User's Manual* describes the hardware features of the Mote Processor Radio (MPR) platforms and Mote Interface Boards (MIB) for network base stations and programming interfaces. It is intended for understanding and leveraging Crossbow's Smart Dust hardware design in real-world sensor network, smart RFID, and ubiquitous computing applications. Table 1-1 below lists the models in this *Manual*. Table 1-2 below summarizes the main features of each Mote.

Table 1-1. *This User's Manual covers these MPR and MIB models.*

MPR	2400 (MICAz)	400/410/420 (MICA2)	500/510/520 (MICA2DOT)	300/310 (MICA)
MIB	600	510	500	300

Table 1-2. *Mote Product Summary.*

Mote Hardware Platform		MICAz	MICA2	MICA2DOT	MICA
Models (as of August 2004)		MPR2400	MPR400/410/420	MPR500/510/520	MPR300/310
MCU	Chip	ATMega128L			ATMega103L
	Type	7.37 MHz, 8 bit		4 MHz, 8 bit	4 MHz, 8 bit
	Program Memory (kB)	128			
	SRAM (kB)	4			
Sensor Board Interface	Type	51 pin		18 pin	51 pin
	10-Bit ADC	7, 0 V to 3 V input		6, 0 V to 3 V input	7, 0 V to 3 V input
	UART	2		1	2
	Other interfaces	DIO, I2C		DIO	DIO, I2C
RF Transceiver (Radio)	Chip	CC2420	CC1000		TR1000
	Radio Frequency (MHz)	2400	315/433/915		433/915
	Max. Data Rate (kbits/sec)	250	38.4		40
	Antenna Connector	MMCX		PCB solder hole	
Flash Data Logger Memory	Chip	AT45DB014B			
	Connection Type	SPI			
	Size (kB)	512			
Default power source	Type	AA, 2x		Coin (CR2354)	AA, 2x
	Typical capacity (mA-hr)	2000		560	2000
	3.3 V booster	N/A			✓

This *Manual* is **not** a software guide to programming the motes in TinyOS/nesC, nor is it a guide to pre-built software packages that run on top of the Motes. The following two resources are available regarding software:

- ❑ *TinyOS Getting Started Guide* by Crossbow Technology, Inc. available on the TinyOS Support Tools CDROM or the Crossbow web site at www.xbow.com under Support>User's Manuals.
- ❑ The TinyOS web site at <http://webs.cs.berkeley.edu/tos>

2 MPR2400 (MICAz)

2.1 Product Summary

The MICAz is the latest generation of Motes from Crossbow Technology. The MPR2400 (2400 MHz to 2483.5 MHz band) uses the Chipcon CC2420, IEEE 802.15.4 compliant, ZigBee ready radio frequency transceiver integrated with an Atmega128L micro-controller. The same MICA2, 51 pin I/O connector, and serial flash memory is used; all MICA2 application software and sensor boards are compatible with the MPR2400.



Figure 2-1. Photo of the MPR2400—MICAz with standard antenna. For the dimensions of the board and locations of the mounting holes, see Figure 2-2.

2.2 Block Diagram and Schematics for the MPR2400 / MICAz

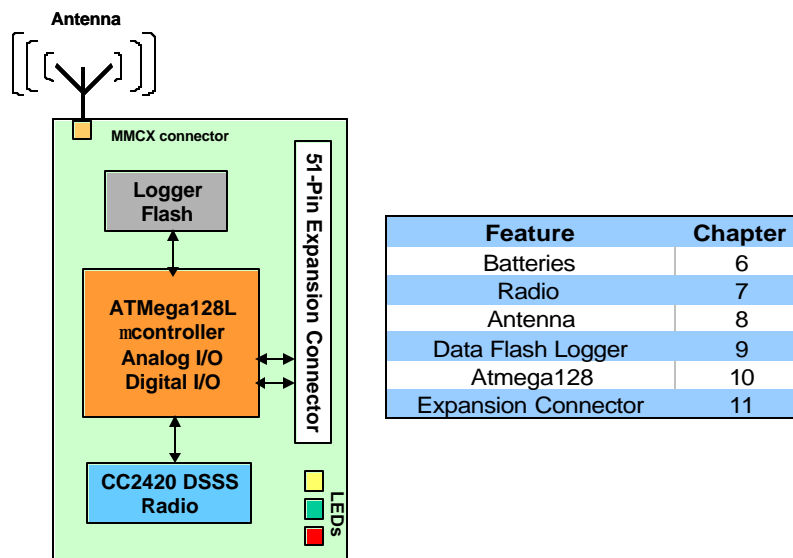
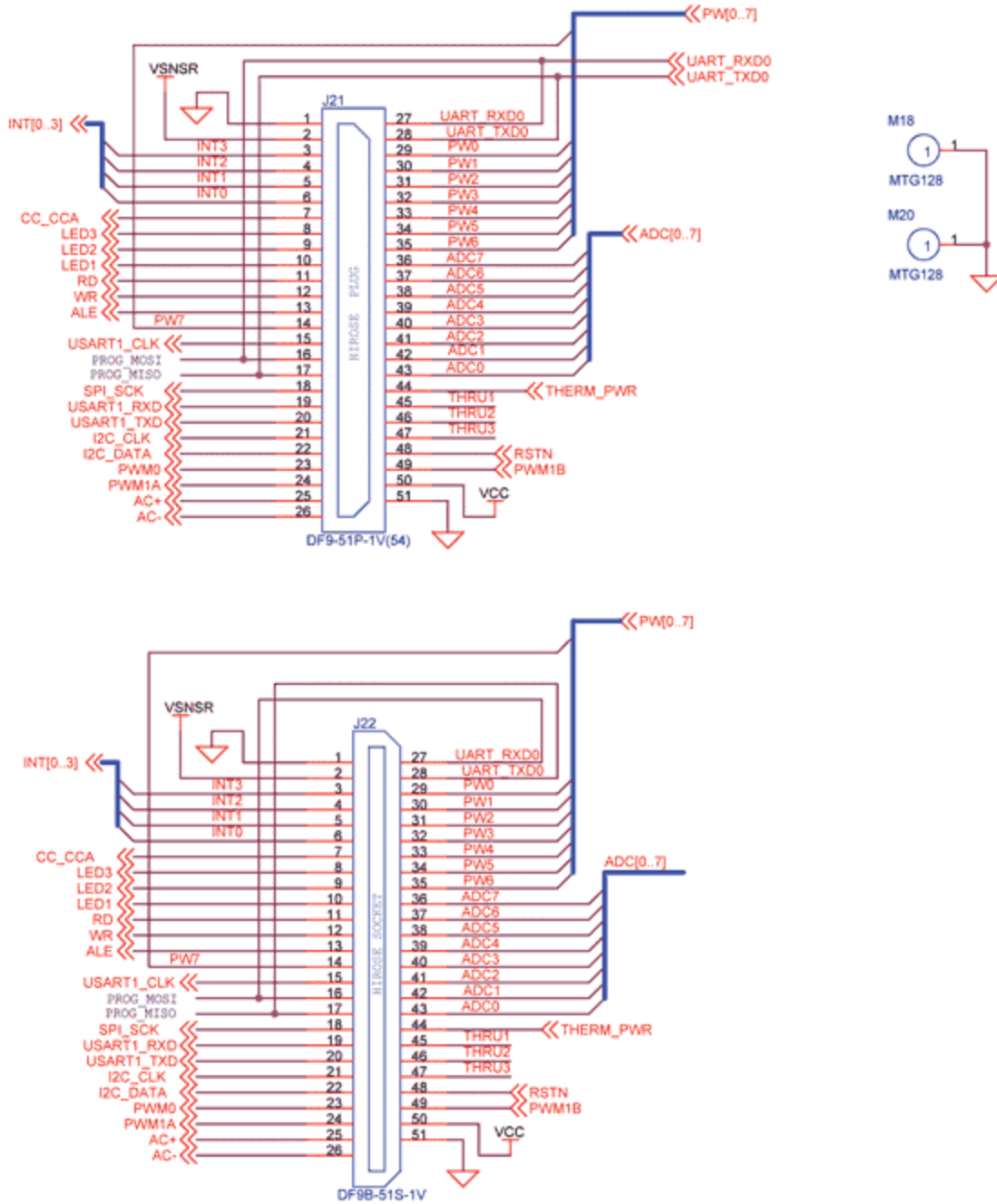
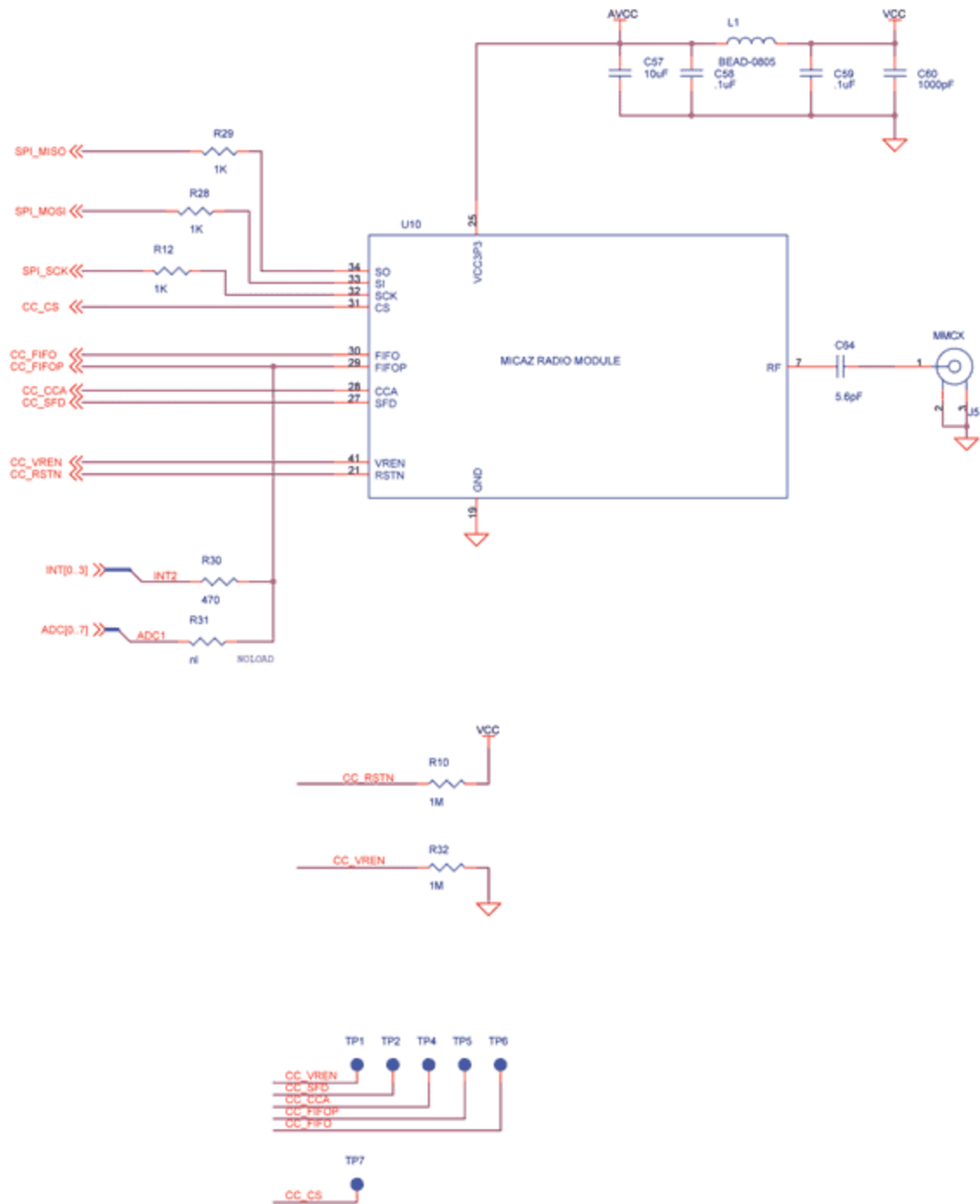

Figure 2-1. Block diagram of the MICA2 and listing of Chapters that discuss the components in greater detail.

2.2.1 51-pin Expansion Connector



2.2.2 CC2420 Radio



2.2.3 Battery, ADC1

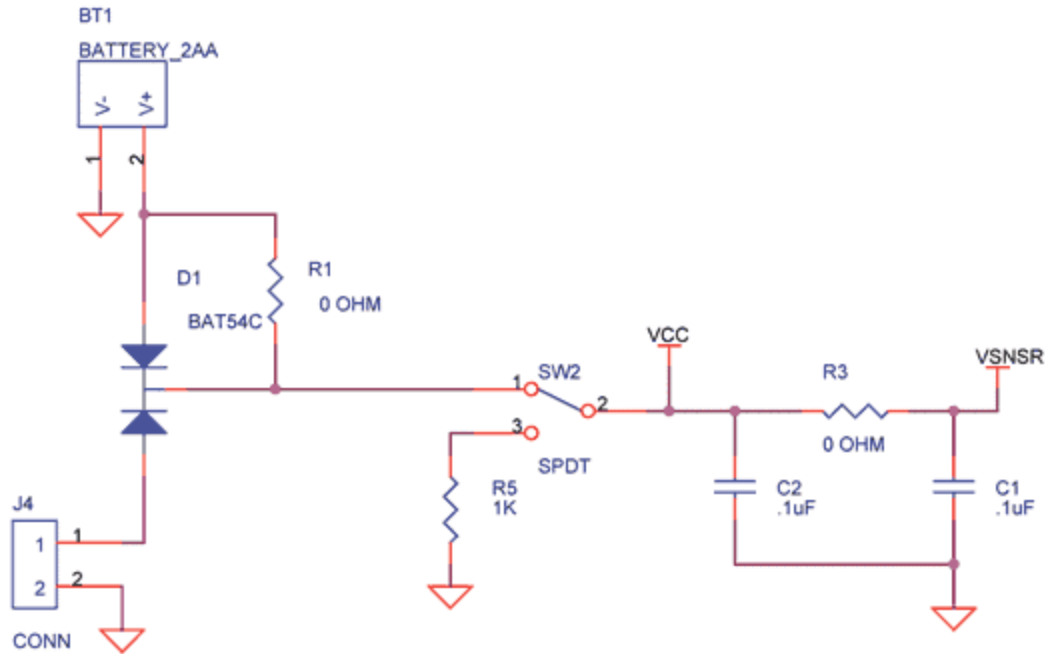

BOARD OPTIONS	
R1	INSTALL
R2	NOT INSTALLED
R4	NOT INSTALLED
R8	NOT INSTALLED
RT1	NOT INSTALLED

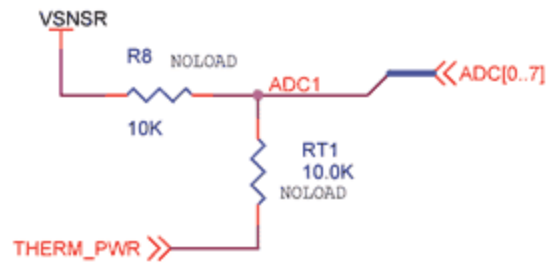

2.3 FCC Certification for the MICAz

The MICAz Mote is classified by the FCC as both a Class A and a Class B digital device. As such this section describes how to operate the equipment so that it does not cause unintended RF interference.

2.3.1 Class A & B Digital Device Compliance

This equipment has been tested by the FCC and found to comply with the limits for a Class A digital device, pursuant to Part 15 of the FCC Rules. These limits are designed to provide reasonable protection against harmful interference when the equipment is operated in a commercial environment. This equipment generates, uses, and can radiate radio frequency energy and, if not installed and used in accordance with the instruction manual, may cause harmful interference to radio communications. There is no guarantee that interference will not occur in a commercial environment. However, operation of this equipment in a residential area is likely to cause harmful interference, which can be determined by turning the equipment off and on. If this is the case the user is encouraged to try and correct the interference by one or more of the following measures:

- ❑ Reorient or locate the receiving antenna.
- ❑ Increase the separation between the equipment and receiver.
- ❑ Connect the equipment into an outlet on a circuit different from that to which the receiver is connected.
- ❑ Consult the dealer or an experienced radio/TV technician for help.

If these measures do not correct for RF interference, the user will be required to correct the interference at his own expense.

 **WARNING:** Any modifications to the unit, unless expressly approved by Crossbow Technology, Inc. could void the user's authority to operate the MICAz Mote (also referred to as "equipment" in this Section).

3 MPR400/MPR410/MPR420 (MICA2)

3.1 Product Summary

The MICA2 Motes come in three models according to their RF frequency band: the MPR400 (915 MHz), MPR410 (433 MHz), and MPR420 (315 MHz). The Motes use the Chipcon CC1000, FSK modulated radio. All models utilize a powerful Atmega128L micro-controller and a frequency tunable radio with extended range. The MPR4x0 and MPR5x0 radios are compatible and can communicate with each other. (The $x = 0, 1, \text{ or } 2$ depending on the model / frequency band.)

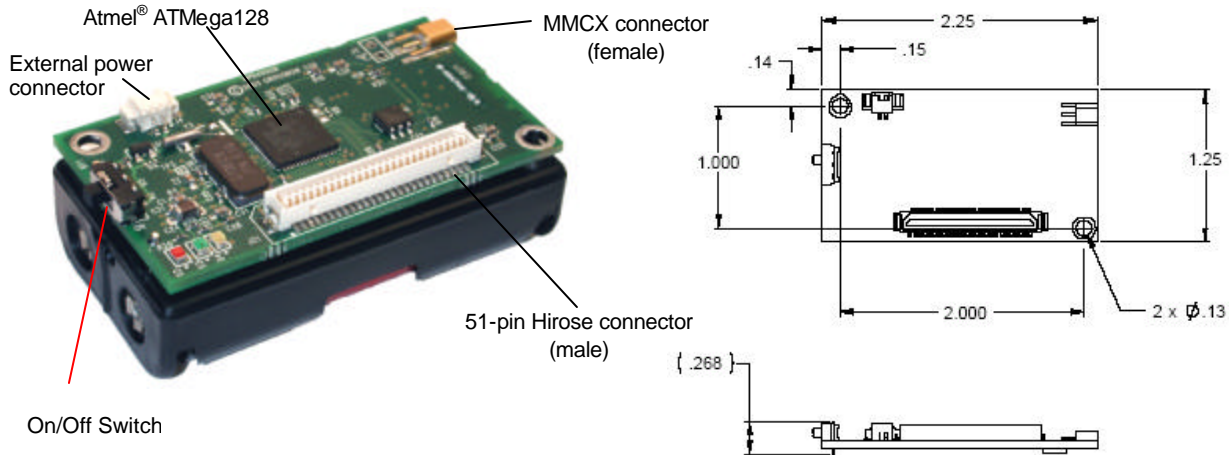

Figure 3-1. Left: Photo of a MICA2 (MPR4x0) without an antenna. Right: Top and plan views showing the dimensions and hole locations of the MICA2 PCB without the battery pack.

3.2 Block Diagram and Schematics: MPR400/410/420

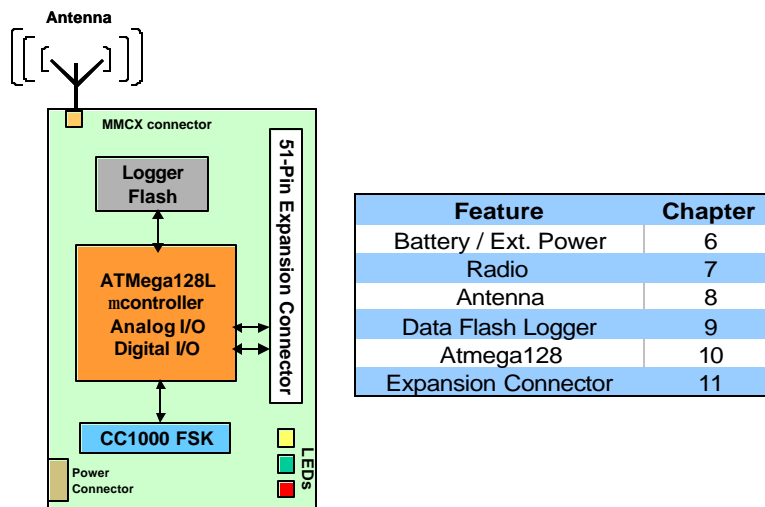
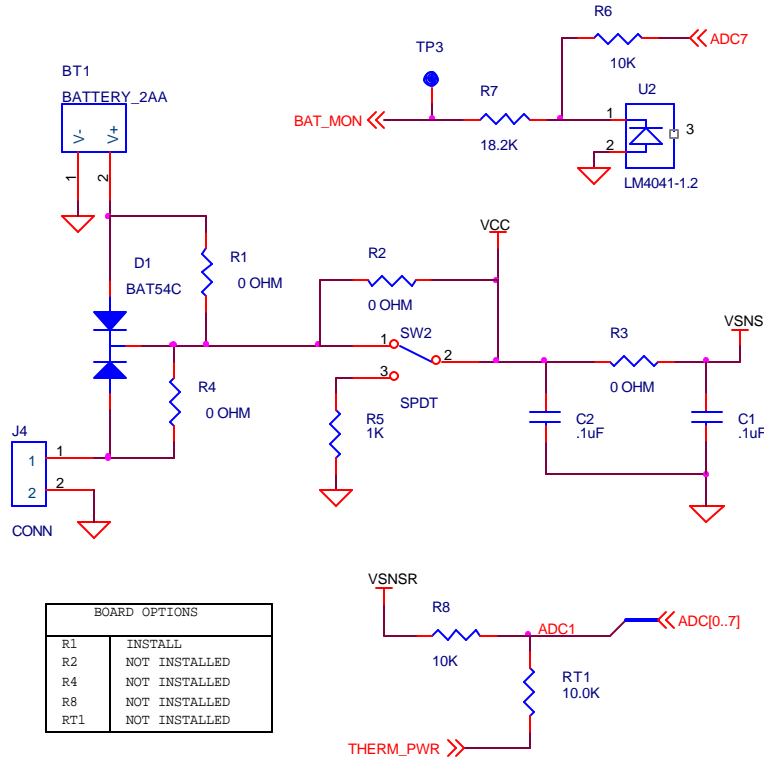

Figure 3-2. Block diagram of the MICA2 and listing of Chapters that discuss the components in greater detail.



3.2.1 Battery, Power, and ADC1



3.2.2 CC1000

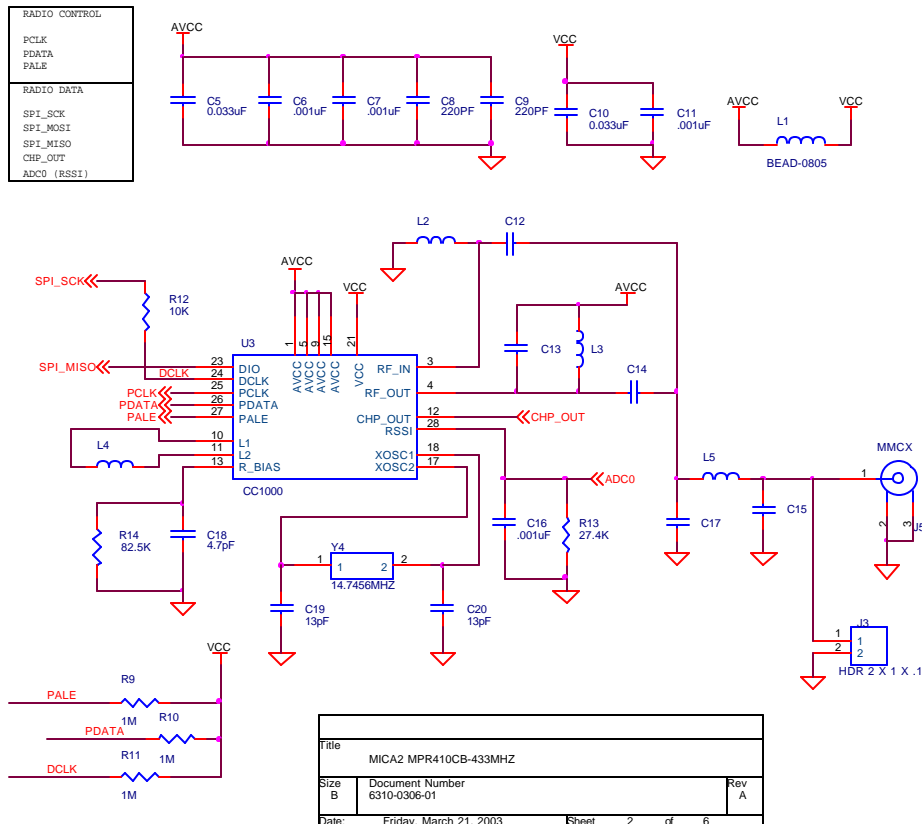



3.2.3 51-pin Expansion Connector: Location J21

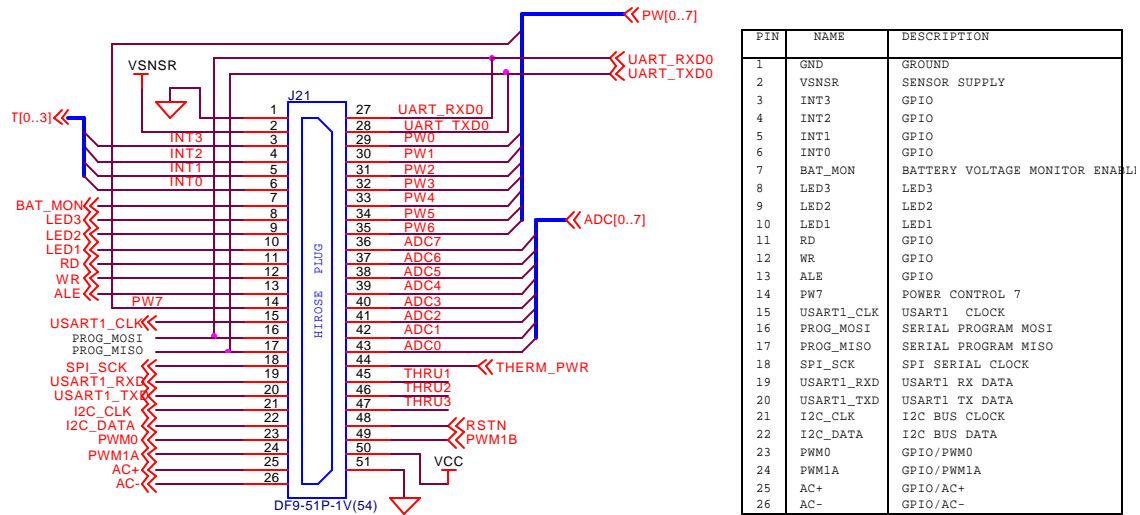

3.2.4 51-pin Expansion Pads: Location J22

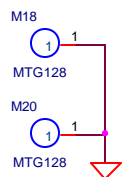
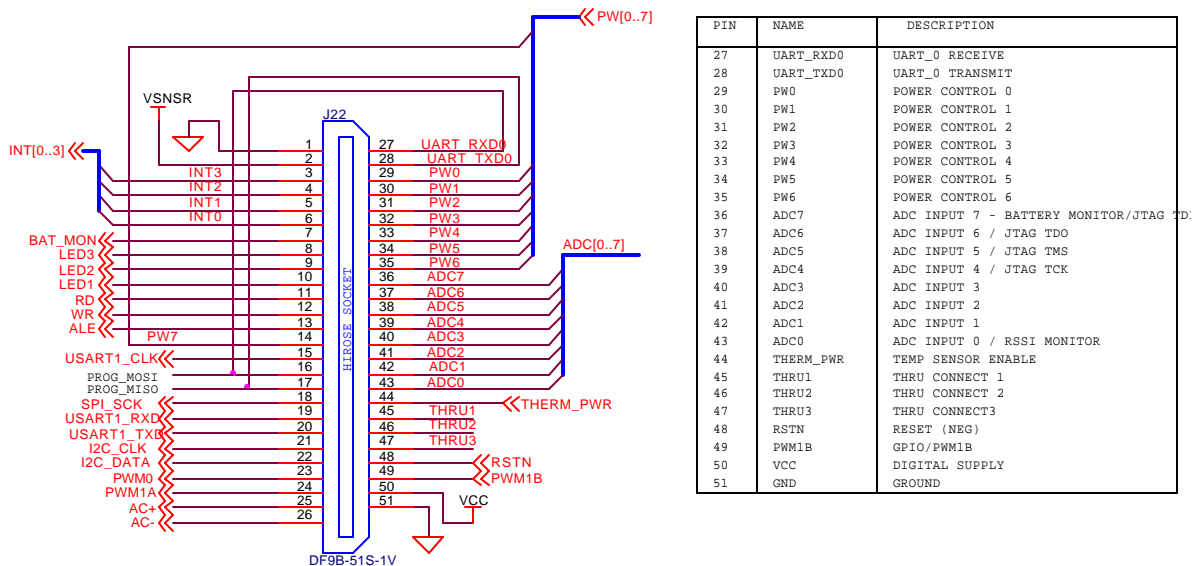

CROSSBOW TECHNOLOGY, INC.		
Title MICA2 MPR410CB-433MHZ		
Size B	Document Number 6310-0306-01	Rev A
Date: Friday, March 21, 2003	Sheet 4 of 6	



3.2.5 ATmega128L

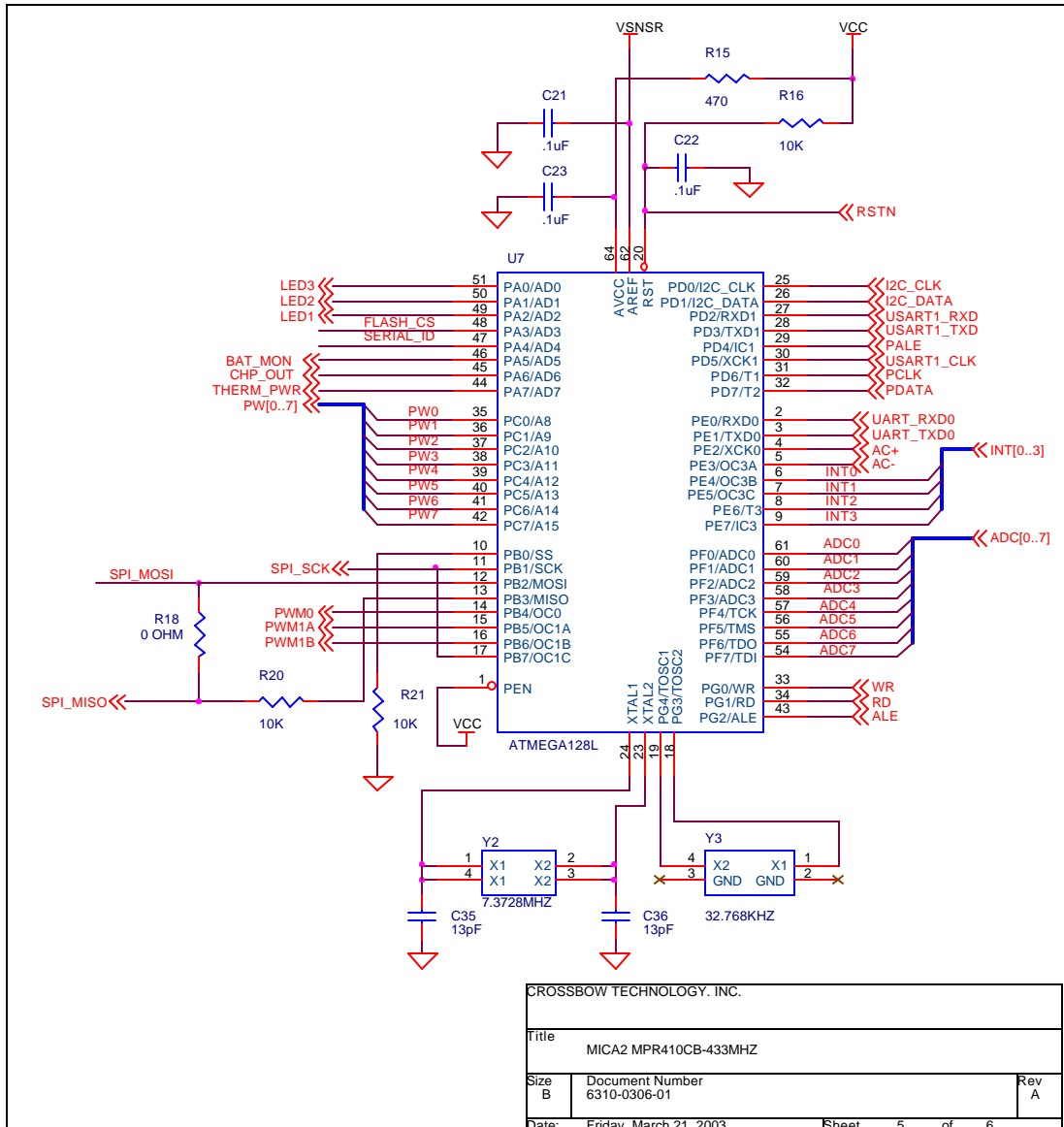

CROSSBOW TECHNOLOGY, INC.		
Title MICA2 MPR410CB-433MHZ		
Size B	Document Number 6310-0306-01	Rev A
Date: Friday, March 21, 2003	Sheet 5	of 6



3.2.6 Flash Memory, Serial ID, LEDs, USART

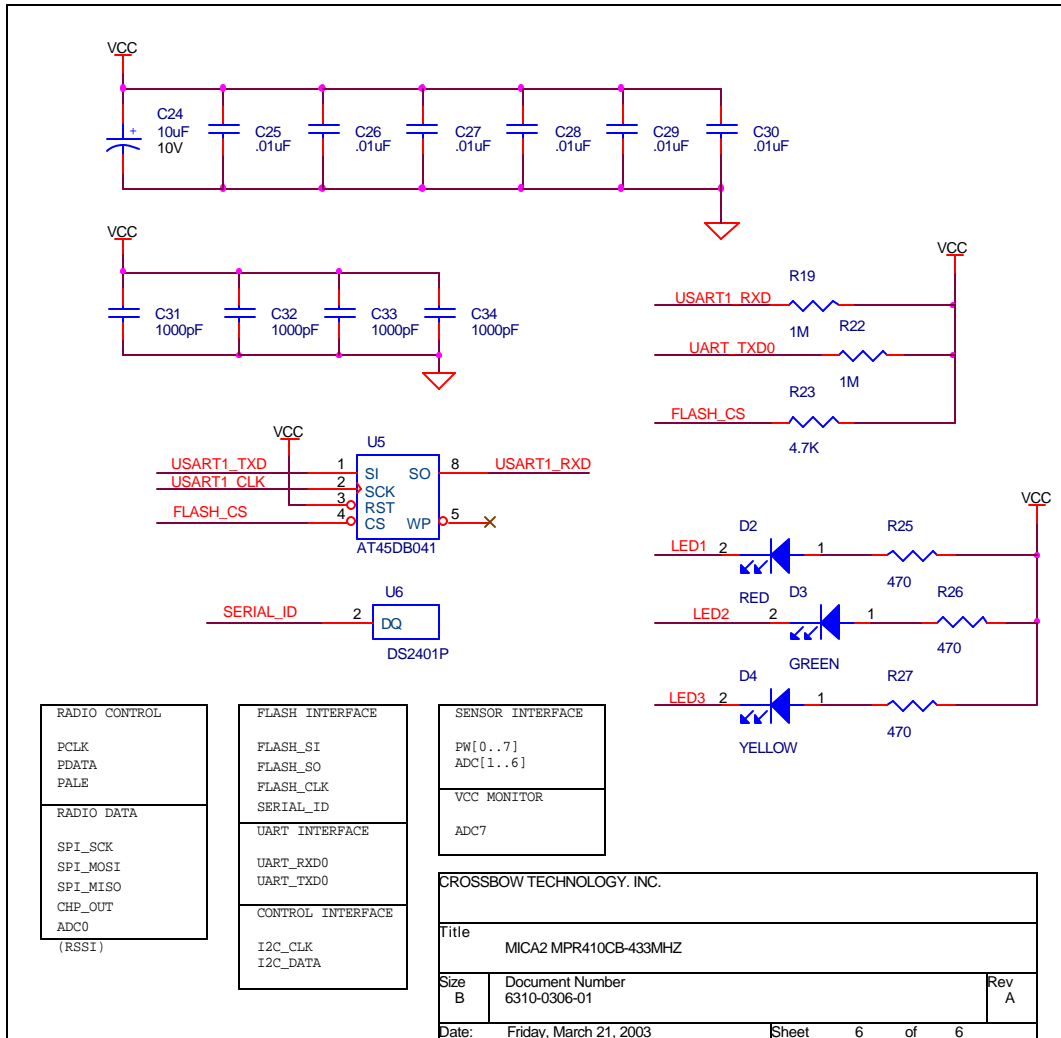



4 MPR500/MPR510/MPR520 (MICA2DOT)

4.1 Product Summary

The MICA2DOT is a Mote designed for applications where physical size is important. Like the MICA2, these are available in three models according to the frequency of the RF transceiver: the MPR500 (915 MHz), MPR510 (433 MHz), and MPR520 (315 MHz). The Motes use the Chipcon CC1000 FSK-modulated radio. All models utilize a powerful ATmega128L micro-controller and a frequency tunable radio with extended range. The MPR4x0 and MPR5x0 radios are compatible and can communicate with each other as long as the “x” is the same number.

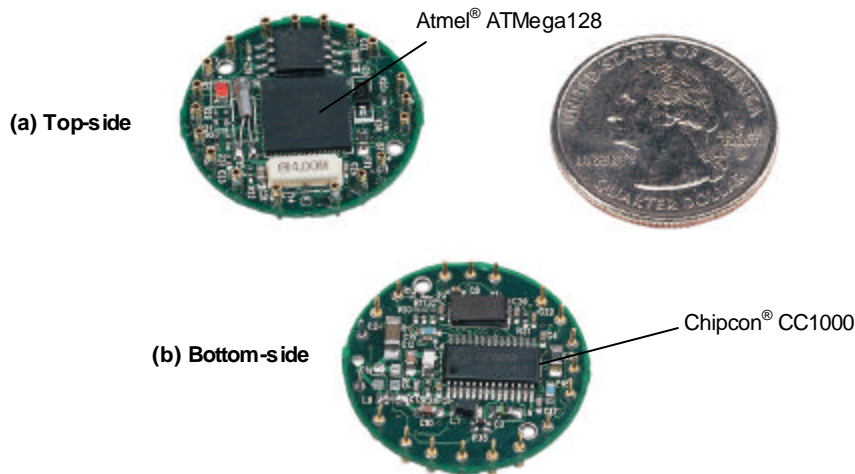

Figure 4-1. Photos of the MICA2DOT shown next to a US quarter: a) Top-side and b) Bottom-side. Typically the MICA2DOT has a 3 V coin-cell battery holder attached to the bottom-side, but it has been removed to show the details.

4.2 On-board Thermistor

The MICA2DOT Mote has an on-board thermistor (Panasonic ERT-J1VR103J) which is a surface mount component. It is on the ATmega128 side of the board at the location labeled “RT1.” Its output is at ADC1 and is enabled by setting PW6 (PC6/A14) to “LO” and PW7 (PC7/A15) to “HI.”

The Mote’s ADC output can be converted to degrees kelvin in the 273.15 K to 323.15 K (0°C to 50 °C) range using the *Steinhart-Hart* equation, which is a widely used third-order approximation.

$$T(K) = \frac{1}{a + b \ln R_{thr} + c(\ln R_{thr})^3}$$

where:

$$R_{thr} = \frac{R_1 \times ADC}{(ADC_{FS} - ADC)}$$

and a , b and c are called the *Steinhart-Hart* parameters with the following values:

$$a = 0.00130705$$

$$b = 0.000214381$$

$$c = 0.000000093$$

$$R_1 = 10 \text{ k}\Omega$$

$$ADC_FS = 1023$$

ADC = output value from the Mote's ADC measurement.

4.3 Block Diagram and Schematics for the MPR500/510/520 MICA2DOT

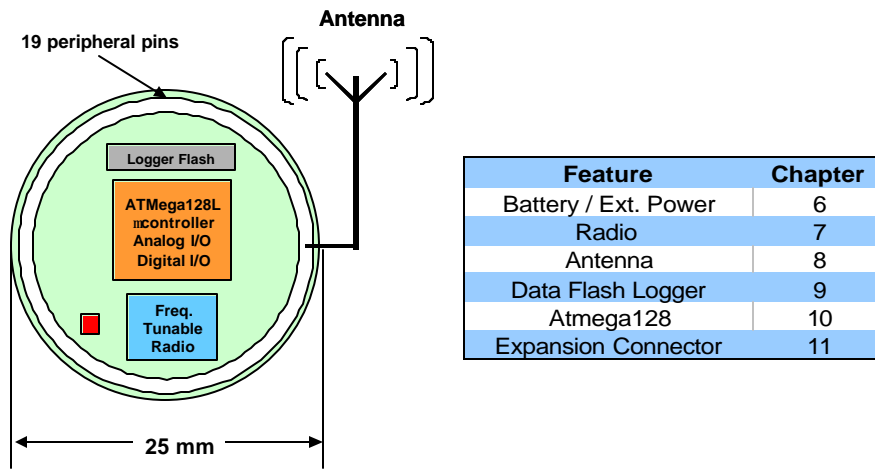
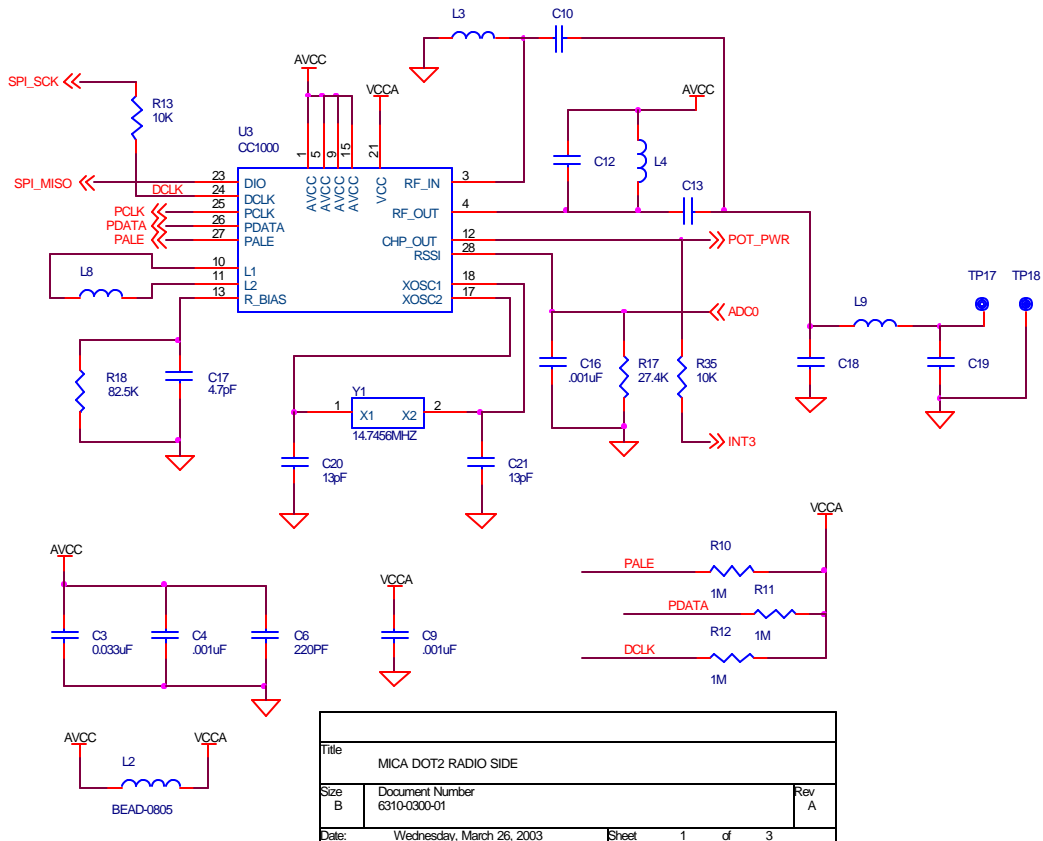

Figure 4-1. Block diagram of the MICA2DOT and listing of Chapters that discuss the components in greater detail.



4.3.1 MICA2DOT CC1000 Radio Side





4.3.2 MIC2DOT ATmega128L, ADC Interfaces, Battery

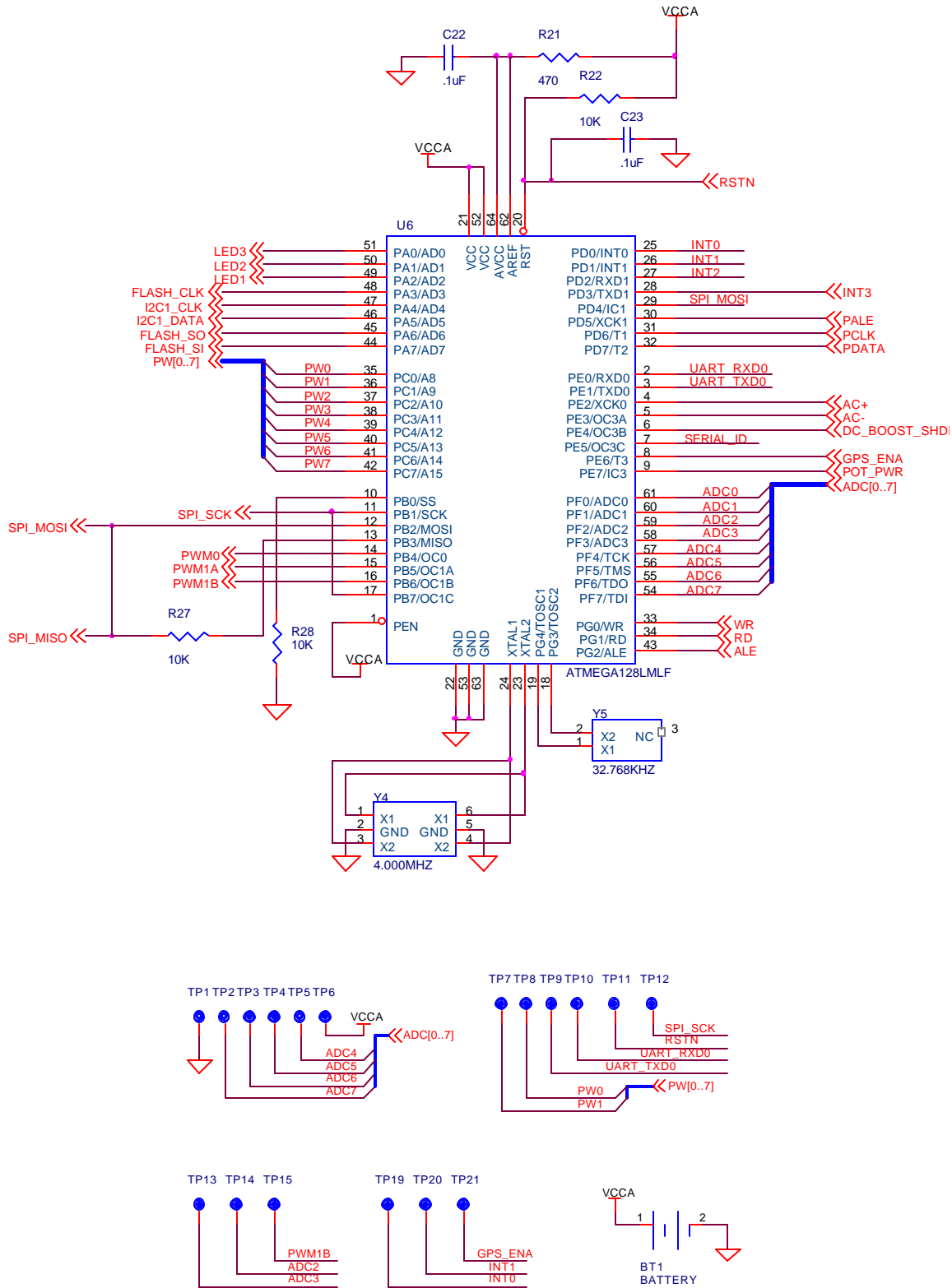



4.3.3 Data Flash Logger/Serial ID, On-board Thermistor, LED

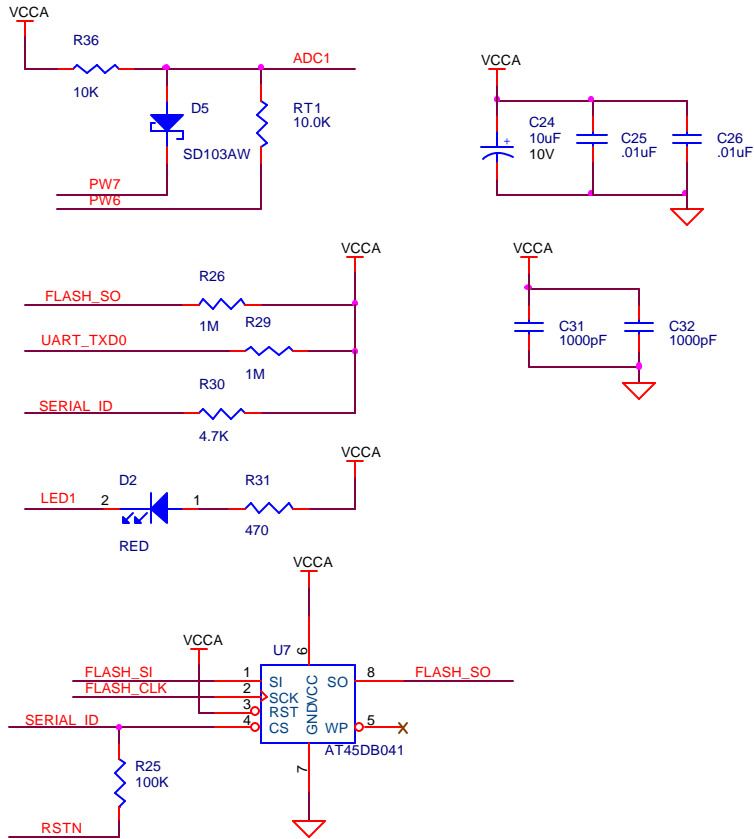

5 MPR300/MPR310 (MICA)

◀ **NOTE:** The MICA Mote has been discontinued by Crossbow since December 2003.

The MICA Mote was the second generation Mote module used in many ground breaking research and development efforts. The MPR300/310 includes a powerful Atmel ATMega128L. It used an amplitude shift keying radio—the TR1000—by RF Monolithics, Inc.

5.1 Schematic

Schematics for the MPR300/410 Mote can be found at:

<http://today.cs.berkeley.edu/tos/hardware/hardware.html>

6 POWER

6.1 Battery Power

All motes are designed for battery power. The MICA2 and MICAz form factors are designed to match up with two AA batteries; however any battery combination (AAA, C, D, etc., cells) can be used provided that the output is between 2.7 VDC to 3.6 VDC.

The MPR500 (915 MHz band), MPR510 (433 MHz band), and MPR520 (315 MHz band, Japan specific) MICA2DOT form factor is designed to match up with a single coin cell battery; however any battery combination (AAA, C, D, etc., cells) can be used provided that the output is between 2.7–3.6VDC.

Table 6-1. Batteries for the Mote Platforms.

Mote Hardware Platform	Standard Battery (# required)	Typical Battery Capacity (mA-hr)	Practical Operating Voltage Range (V)
MICAz	AA (2)	2000, Alkaline	3.6 to 2.7
MICA2	AA (2)	2000, Alkaline	3.6 to 2.7
MICA2DOT	Coin	560, Li-ion	3.6 to 2.7

Care should be used in selecting the battery and its capacity to match the energy needs of the motes and their required operating span. Also make sure that the temperature range and associated capacity degradation are looked at prior to deployment. Table 6-2 below provides some useful guidance on current consumption of various system components.

Table 6-2. Current Requirements for the Motes in Various Operation.

Operating Current (mA)	MICAz	MICA2	MICA2DOT
ATMega128L, full operation	12 (7.37 MHz)	12 (7.37 MHz)	6 (4MHz)
ATMega128L, sleep	0.010	0.010	0.010
Radio, receive	19.7	7	7
Radio, transmit (1 mW power)	17	10	10
Radio, sleep	0.001	0.001	0.001
Serial flash memory, write	15		
Serial flash memory, read	4		
Serial flash memory, sleep	0.002		

Table 6-3 section below provides some useful guidance on how to predict battery life. The spreadsheet can be found at <http://www.xbow.com> under the Support section.

Table 6-3. Estimate of battery life operation for a Mote.

SYSTEM SPECIFICATIONS		
Currents		Example Duty Cycle
Processor		
Current (full operation)	8 mA	1
Current sleep	8 μ A	99
Radio		
Current in receive	8 mA	0.75
Current transmit	12 mA	0.25
Current sleep	2 μ A	99
Logger Memory		
Write	15 mA	0
Read	4 mA	0
Sleep	2 μ A	100
Sensor Board		
Current (full operation)	5 mA	1
Current sleep	5 μ A	99
Computed mA-hr used each hour		
Processor		0.0879
Radio		0.0920
Logger Memory		0.0020
Sensor Board		0.0550
Total current (mA-hr) used		0.2369
Computed battery life vs. battery size		
Battery Capacity (mA-hr)		Battery Life (months)
250		1.45
1000		5.78
3000		17.35

◀ **NOTE:** In most Mote applications, the processor and radio run for a brief period of time, followed by a sleep cycle. During sleep, current consumption is in the micro-amps as opposed to milli-amps. This results in very low-current draw the majority of the time, and short duration spikes while processing, receiving, and transmitting data. This method extends battery life; however, due to the current surges, it reduces specified battery capacity. Battery capacity is typically specified by the manufacturer for a constant nominal current drawn.

6.2 External Power

The MICA2 and MICAz can be externally powered through either:

1. The 51-pin connector will supply power and ground to the unit. Refer to connector description.
2. The 2-pin Molex connector. Molex part number 53261-0290, Digi-Key part number WM1753-ND. (See Figure 6-4 below.)

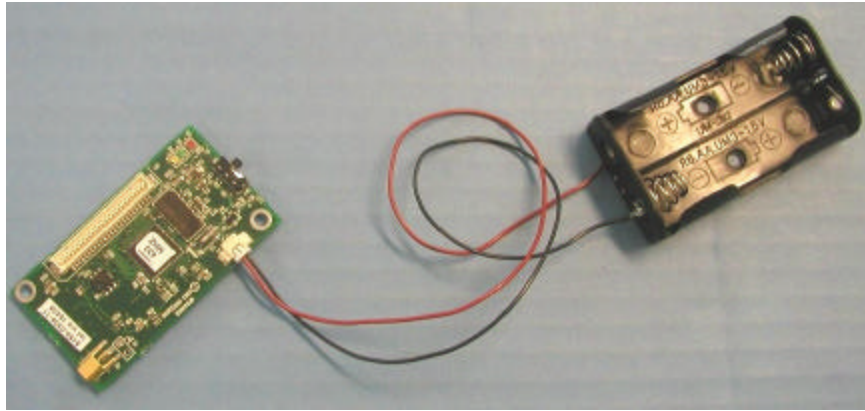

Figure 6-4. Photo of using the Molex connector to attach the AA battery pack. Photo courtesy of Nick Sitar, UC Berkeley, 2004.

6.3 MICAz Battery Voltage Monitor

The MICAz has an accurate internal voltage reference that can be used to measure battery voltage (V_{batt}). Since the eight-channel ADC on the ATmega128L uses the battery voltage as a full scale reference, the ADC full scale voltage value changes as the battery voltage changes. In order to track the battery voltage, the precision voltage reference (band gap reference) is monitored to determine the ADC full-scale (ADC_FS) voltage span which corresponds to V_{batt} .

To compute the battery voltage:

1. Program the application code to measure ADC channel 30 – the Internal Bandgap Voltage reference.
2. Compute battery voltage, V_{batt} , from ADC reading (ADC_Count) by:

$$V_{batt} = V_{ref} \times ADC_FS / ADC_Count$$

where:

V_{batt} = Battery voltage

ADC_FS = 1024

V_{ref} = Internal voltage reference = 1.223 volts

ADC_Count = Data from the ADC measurement of Internal Voltage reference

The TinyOS component *VoltageM.nc* can be wired into an application to provide this measurement capability. The reserved keyword `TOS_ADC_VOLTAGE_PORT` is mapped to ADC Channel 30 in the MICAz.

6.4 MICA2 Battery Voltage Monitor

The MICA2 units have an accurate voltage reference that can be used to measure battery voltage (V_{batt}). Since the eight-channel, ATmega128L ADC uses the battery voltage as a full scale reference, the ADC full scale voltage value changes as the battery voltage changes. In order to calibrate the battery voltage a precision external voltage reference is required. The MICA2 uses an LM4041 (Mfg: National Semiconductor) 1.223 V reference (V_{ref}) attached to ADC channel 7.

⚠ **NOTE:** ADC channel 7 is also used for JTAG debugging on the Atmega128 processor. MICA2s and MICA2DOTs ship with the JTAG fuse enabled. When this fuse is enabled the input impedance of channel 7 is lowered which affects the voltage reference measurement. The fuse must be disabled if ADC channel 7 is used. See below for information on setting ATmega128L fuses.

To compute the battery voltage:

1. Set the BAT_MON processor pin (PA5/AD5) to HI.
2. Program the application code to measure ADC Channel 7.
3. Compute battery voltage, V_{batt} , from Channel 7's data by:

$$V_{batt} = V_{ref} \times ADC_FS / ADC_Count$$

where:

V_{batt} = Battery voltage

ADC_FS = 1024

V_{ref} = External voltage reference = 1.223 V

ADC_Count = Data from the ADC measurement of Channel 7

6.5 MICA2DOT Battery Voltage Monitor

Unlike the MICAz and the MICA2, the MICA2DOT uses a Schottky reference diode (S103AW) as a voltage reference that can be used to measure battery voltage (V_{batt}). Since the eight-channel, ATmega128L ADC uses the battery voltage as a full-scale reference, the ADC full scale (ADC_FS) voltage value changes as the battery voltage changes. In order to calibrate the battery voltage an external voltage reference (V_{ref}) is required.

To compute the battery voltage:

1. Set processor pins PW7 (PC7/A15) to LO and PW6 (PC6/A14) to HI.
2. Program the application code to measure ADC Channel 1 (ADC1).
3. Compute battery voltage, V_{batt} , from channel 1's data by:

$$V_{batt} = V_{ref} \times ADC_FS / ADC_Count$$

where:

V_{batt} = Battery voltage

ADC_FS = 1024

V_{ref} = External voltage reference = 0.6 volts

ADC_Count = Data from the ADC measurement of Channel 1

7 RADIOS

7.1 MICA2 and MICA2DOT

7.1.1 *Radio Considerations*

The radio on the MICA2 and MICA2DOT is capable of multiple channel operation, within the intended band of operation. The MPR420/MPR520 can span up to 4 channels of operation in the 315 MHz band, the MPR410/MPR510 can span up to 4 channels of operation in the 433 MHz band (433.05–434.79 MHz). The MPR400/MPR500 can operate in two frequency regions: 868–870 MHz (up to 4 channels) and 902–928 MHz (up to 54 channels). The actual number of possible channels is higher for all the MICA2/MICA2DOT motes. However, it is recommended that the adjacent channel spacing should be **at least** 500 kHz to avoid adjacent channel interference thereby reducing the number of available channels. A tutorial on how to change frequency is available at <http://www.tinyos.net/tinyos-1.x/doc/mica2radio/CC1000.html>.

7.1.2 *Radio Transmission Power*

The radio on the MICA2/MICA2DOT can be adjusted for a range of output power levels. The register in the radio that controls the RF power level is designated PA_POW at address 0x0B, and the values and their corresponding RF outputs are provided on Table 7-1 below. It shows the closest programmable value for output powers in steps of 1 dBm. For power down mode the Chipcon datasheet says, “the PA_POW should be set to 00h [0x00] for minimum leakage current.”

Table 7-1. Chipcon® CC1000 Output Power (PA_POW) Settings and Typical Current Consumption. From Smart RF® CC1000 Preliminary Datasheet (rev. 2.1), 2002-04-19, p. 29 of 48.

Pout (dBm)	PA_POW (hex) 433/315 MHz	Current Consumption, typ. (mA)	PA_POW (hex) 915 MHz	Current Consumption, typ. (mA)
-20	0x01	5.3	0x02	8.6
-19	0x01	6.9	0x02	8.8
-18	0x02	7.1	0x03	9.0
-17	0x02	7.1	0x03	9.0
-16	0x02	7.1	0x04	9.1
-15	0x03	7.4	0x05	9.3
-14	0x03	7.4	0x05	9.3
-13	0x03	7.4	0x06	9.5
-12	0x04	7.6	0x07	9.7
-11	0x04	7.6	0x08	9.9
-10	0x05	7.9	0x09	10.1
-9	0x05	7.9	0x0b	10.4
-8	0x06	8.2	0x0c	10.6
-7	0x07	8.4	0x0d	10.8
-6	0x08	8.7	0x0f	11.1
-5	0x09	8.9	0x40	13.8
-4	0x0a	9.4	0x50	14.5
-3	0x0b	9.6	0x50	14.5
-2	0x0c	9.7	0x60	15.1
-1	0x0e	10.2	0x70	15.8
0	0x0f	10.4	0x80	16.8
1	0x40	11.8	0x90	17.2
2	0x50	12.8	0xb0	18.5
3	0x50	12.8	0xc0	19.2
4	0x60	13.8	0xf0	21.3
5	0x70	14.8	0xff	25.4
6	0x80	15.8		
7	0x90	16.8		
8	0xc0	20.0		
9	0xe0	22.1		
10	0xff	26.7		

◀ **NOTE:**

In order to comply with "Bijjacku" (Japanese standard), the Radio Transmit power for the MICA2 must have a PA_POW set to lowest value, 0x01.

The radio on the MICA2/MICA2DOT also provides a measurement of the received signal strength, referred to as RSSI. This output is measured on ADC channel 0 and is available to the software. Some versions of TinyOS provide this measurement automatically, and others must be enabled by the user. The conversion from ADC counts to RSSI in dBm is given by:



$$V_{RSSI} = V_{batt} \times ADC_Counts / 1024$$

$$RSSI(dBm) = -51.3 \times V_{RSSI} - 49.2 \text{ for 433 and 315 MHz Motes}$$

$$RSSI(dBm) = -50.0 \times V_{RSSI} - 45.5 \text{ for 915 MHz Motes}$$

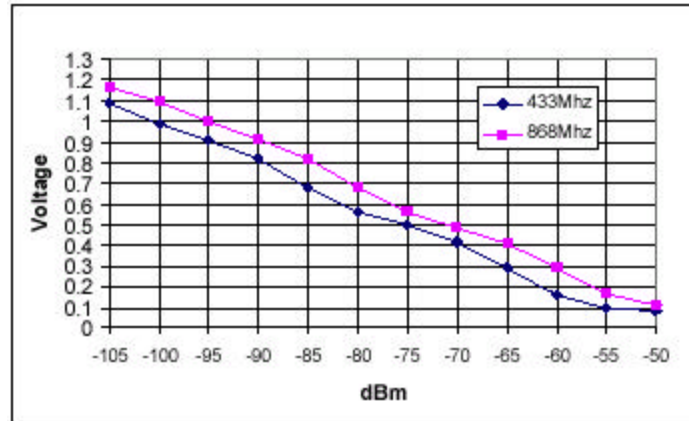

Figure 7-2. Graph showing V_{RSSI} versus the received signal strength indicator (dBm). From the ChipCon's SmartRF[®] CC1000 PRELIMINARY Datasheet (rev. 2.1), p. 30. 2002.

Care should be taken to provide an antenna that provides proper coverage for the environment expected. Range and performance are **strongly** affected by choice of antenna and antenna placement within the environment. In addition, care must be taken to ensure compliance with FCC article 15 regulations for intentional radiators. An omni directional antenna such as a quarter wavelength whip should be sufficient to meet most user requirements.

⚠ **WARNING:** The radio on the MICA2 has an extremely sensitive receiver, which can be interfered with by an adjacent local oscillator from another MICA2. A distance of at least 2 feet should be maintained between MICA2 units to avoid local oscillator interference.

7.2 MICAz

7.2.1 Radio RF Channel Selection

The MICAz's CC2420 radio can be tuned from 2.048 GHz to 3.072 GHz which includes the global ISM band at 2.4 GHz. IEEE 802.15.4 channels are numbered from 11 (2.405 GHz) to 26 (2.480 GHz) each separated by 5 MHz. The channel can be selected at run-time with the TOS CC2420Radio library call `CC2420Control.TunePreset(uint8_t chnl)`. By default channel 11 (2480 MHz) is selected.

7.2.2 Radio Transmission Power

RF transmission power is programmable from 0 dBm (1 mW) to -25dBm. Lower transmission power can be advantageous by reducing interference and dropping radio power consumption from 17.5 mA at full power to 8.5 mA at lowest power. RF transmit power is controlled using the TOS `CC2420Radio` library call `CC2420Control.SetRFPower(uint8_t power)` where power is an 8-bit code selected from the following:

Power Register (code)	MICAz TX RF Power (dBm)
31	0
27	-1
23	-3
19	-5
15	-7
11	-10
7	-15
3	-25

The RF received signal strength indication (RSSI) is read directly from the CC2420 Radio. In TinyOS the RSSI is automatically returned in the `TOSMsg->strength` field with every radio packet received. Typical RSSI values for a given RF input level are shown in Figure 7-1 below.

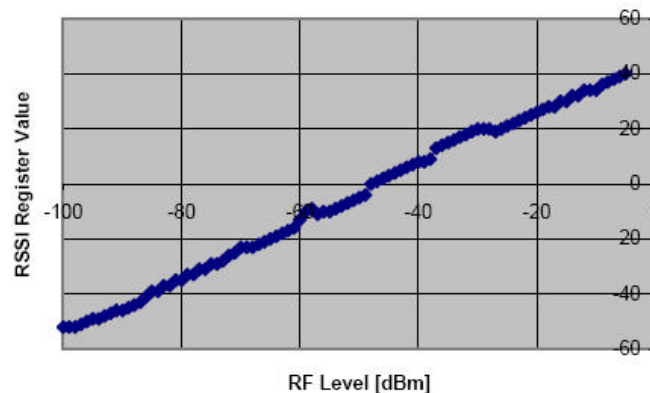

Figure 7-2. Typical RSSI value versus input RF level in dBm.

7.2.3 Known MICAz and TinyOS Compatibility Issues

1. `#define PLATFORM_MICAZ`

In general this `#define` should be added to various applications/libraries wherever the text `PLATFORM_MICA2` is found.

2. ATmega128L Timer2 Use

Timer2 is used for high resolution (32uSec) timing in the CC2420Radio stack. The module `HPLTimer2.nc` located under the `tinyos-1.x/tos/platform/micaz/` directory provides the `Timer2` resources to `AsyncTimerJiffy` component for this service. Applications that use `Timer2` will have to be modified to avoid conflicts with its use for the MICAz platform radio stack.

3. INT2 GPIO Line

MICA I/O signal INT2 (Port E, pin 6 on ATmega128 or 51-pin Hirose connector pin 4) is used internally to the MICAz for the CC2420 Radio Receiver FIFO Ready interrupt. Use of INT2 for any other purpose must be done with care. Specifically, the Port configuration (input, active low) must be restored following use in other software modules.

◀ **NOTE:** Programmers should be cautioned that the MICAz receiver radio stack (*CC2420RadioM.nc*) will be disabled if the INT2 pin is reprogrammed/re-tasked by another TOS component.

4. MTS300/310 (a.k.a., *micasb*) Temperature Sensor

- INT2 control line is used on the MTS300/310 (*micasb*) for enabling the thermistor. During temperature measurement, interrupts from the MICAz radio receiver are inhibited. MICAz radio received packets are buffered in the CC2420 RX FIFO. If the MTS300/310's thermistor is enabled for too long the receiver buffer may overflow. During temperature measurements dropout in data reading. This is due to receipt of a radio packet which will strobe the INT2 and thus affect the thermistor voltage. Following temperature measurement, the MTS300/310 driver must restore the INT2 port to configuration used for handling interrupts from the CC2420 radio. Symptom of not restoring the INT2 port correctly is all that radio reception stops.
- A Temporary Fix the Temperature Sensor Issue:
 - INT2 Control
A modified *PhotoTempM.nc* module is provided in *tinys-1.x/tos/platform/micaz/*. This module restores INT2 port following each measurement.
 - Temperature data drop out
Software can be added to exclude/reject a temperature reading differentials that exceed what is physically possible from one sample to the next.
 - Hardware can be modified to buffer/overdrive CC2420 Radio's packet received flag during temperature measurements. The following two changes are suggested.
 - a. *MTS300/310 Sensor Board Module*: Remove capacitor C1 (located near RT1 thermistor)
 - b. *MICAz Module*: Change resistor at location R31 to 10 k Ω .



8 ANTENNAS

8.1 Radio/Antenna Considerations

Care should be taken to provide an antenna that provides proper coverage for the environment expected. Range and performance are strongly affected by choice of antenna and antenna placement within the environment. In addition, care must be taken to ensure compliance with FCC article 15 regulations for intentional radiators. Because of its small physical size, the usual antenna chosen is a length of insulated wire one-quarter wavelength long for the frequency of interest. This type of antenna is often called a *monopole* antenna, and its gain is ground plane dependent.

Antenna lengths for the different radio frequencies are provided in Table 8-1.

Table 8-1. Antenna lengths for quarter wavelength whip antennas. The part number's for the connectorized antennas are listed.

Name	Model	Whip Antenna Length (inches)	Crossbow Part No.
MICA2/MICA2DOT	MPR400 (916 MHz)	3.2	8060-0011-01
MICA2/MICA2DOT	MPR410 (433 MHz)	6.8	8060-0011-02
MICA2/MICA2DOT	MPR420 (315 MHz)	9.4	8060-0011-03
MICAZ	MPR2400 (2400 MHz)	1.2	8060-0011-04

8.2 Connectors for the MICA2 and MICAZ and Whip Antennas

The MICA2 and MICAZ have an MMCX connector for attaching an external antenna. These mating connectors can be purchased from Digi-Key. There are two manufacturers—Johnson Components and Hirose Electric Ltd. The mating connectors come in straight and right angle. They also support two different standard varieties of Coaxial cable—RG178 /U and RG 316/U. There are also other vendors who sell MMCX to SMA conversion cables.

Table 8-2. Johnson Components' MMCX mating connectors*

Type	Coax	Digi-Key PN	Johnson PN
Straight Plug	RG178/U	J589-ND	135-3402-001
Straight Plug	RG316/U	J590-ND	135-3403-001
Right Angle	RG178/U	J593-ND	135-3402-101
Right Angle	RG316/U	J594-ND	135-3403-101
Right Angle	RG 316 DS	J595-ND	135-3404-101

*These connectors require the following hand crimp and die set (Digi-Key part # / Johnson part #):
 a) Hand crimp (J572-ND / 140-0000-952), b) Die (JD604-ND / 140-0000-953).

Table 8-3. Hirose MMCX connectors.

Type	Coax	Digi-Key PN	Hirose PN
Straight Plug	RG178/U	H3224-ND	MMCX-J-178B/U



Right Angle	RG178/U	H3221-ND	MMCX-LP-178B/U
Right Angle	RG316/U	H3222-ND	MMCX-LP-316/U

9 FLASH DATA LOGGER AND SERIAL ID CHIP

All Motes feature a 4-Mbit serial flash (Atmel AT45DB041) for storing data, measurements, and other user-defined information. It is connected to one of the USART on the ATmega128L. This chip is supported in TinyOS which uses this chip as micro file system. The serial flash device supports over 100,000 measurement readings. This chip is also used for over-the-air reprogramming services available in TinyOS.

Also on the MICA2 is a 64-bit serial ID chip.

◀ **NOTE:** This device consumes 15 mA of current when writing data.

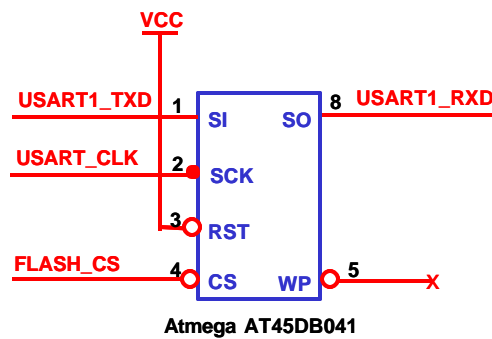



10 ATMEGA128 FUSES

The ATmega128L processor on the Motes has many programmable fuses to control various parameters. Refer to Atmel's technical information for the ATmega128L for a complete discussion of the fuses (http://www.atmel.com/dyn/resources/prod_documents/2467s.pdf). There are two fuses that TinyOS users should be aware of as setting these fuses incorrectly will cause the unit to not operate correctly.

10.1.1 Atmega103 compatibility mode fuse

This fuse put the ATmega128 in the ATmega103 compatible mode. This fuse was set for the older generation MICA units. It must be disabled for MICA2 and MICA2DOTs.

10.1.2 JTAG fuse

This fuse enables users to use the Atmel JTAG pod for in-circuit code debugging. Units are shipped with JTAG enabled. As discussed in the previous section on battery voltage monitoring, if JTAG is enabled, it will cause inaccurate measurements on ADC channel 7.

10.1.3 Using UISP to set fuses

The UISP utility used to download code to the MICAz, MICA2, or MICA2DOT on a programming board can also be used to set and unset fuses of the Atmel[®] ATmega128.

Table 10-1. *UISP Commands for Setting the ATmega128's Fuses.*

Action	Command
Disable JTAG fuse	<code>uisp -dprog=<programmer> --wr_fuse_h=0xD9</code>
Enable JTAG fuse	<code>uisp -dprog=<programmer> --wr_fuse_h=0x19</code>
Enable native 128 mode	<code>uisp -dprog=<programmer> --wr_fuse_e=ff</code>

<programmer> is the device you are using to interface to the Mote from a computer. The current options are `dapa` (for an MIB500), `mib510` for a MIB510; and `EPRB` for a MIB600.

Users can also edit the file called *profile* in the *cygwin/etc/* directory and enter an alias. One example is this alias to disable the JTAG fuse:

```
alias fuse_dis="uisp -dprog=<programmer> --wr_fuse_h=0xD9"
```

Therefore, when `fuse_dis` and is entered into a Cygwin command line, the script will be executed.



11 SENSOR BOARDS & EXPANSION CONNECTORS

Crossbow supplies a variety of sensor and data acquisition boards for the Motes. This Chapter describes the connectors and the functions of the pins for the MICAz, MICA2, MICA, and MICA2DOT.

Information for customized sensor board design is available on the Crossbow web site.

11.1 Sensor Board Compatibility

Table 11-1. *Sensor board compatibility.*

Mote Platform	Mote Interface Connector	Hardware Compatibility with:	Section
MICA2	Use 51 pin connector	MICAz, MICA2 sensor boards	11.2
MICAz	Use 51 pin connector	MICAz, MICA2 sensor boards	11.2
MICA2DOT	Use circular, 19 pin connector	MICA2DOT sensor boards	11.3

11.2 MICAz and MICA2 Expansion Connector

Connection to the MICAz and MICA2 Motes is by a 51-pin connector (see Figure 11-1 below).

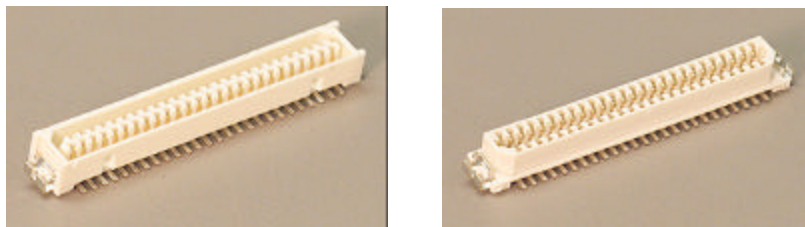

Figure 11-1. *Hirose DF-51P-1V(54)—Digi-Key part no. H2175-ND—on left is used on the MICAz, MICA2, and MICA Motes boards. The Hirose DF9-51S-1V(54)—Digi-Key part no. H2163-ND—on right is the corresponding connector used on the MIB Interface Boards and Stargate Gateways.*

The expansion connector provides a user interface for sensor boards and base stations. The connector includes interfaces for power and ground, power control of peripheral sensors, ADC inputs for reading sensor outputs, UART interfaces, and I2C interface, general-purpose digital IO, and others.



11.2.1 MICAz and MICA2 Sensor Interface.

Table 11-2. MICAz Sensor Interface.

Pin	Name	Description	Pin	Name	Description
1	GND	Ground	27 [Ⓢ]	UART_RXDO	UART_0 Receive
2	VSNR	Sensor Supply	28 [Ⓢ]	UART_TXDO	UART_0 Transmit
3	INT3	GPIO	29	PWO	GPIO/PWM
4	INT2	GPIO	30	PW1	GPIO/PWM
5	INT1	GPIO	31	PW2	GPIO/PWM
6	INT0	GPIO	32	PW3	GPIO/PWM
7 ^{ⓈⓈ}	CC_CCA	Radio Signal	33	PW4	GPIO/PWM
8 [Ⓢ]	LED3	Green LED	34	PW5	GPIO/PWM
9 [Ⓢ]	LED2	Yellow LED	35	PW6	GPIO/PWM
10 [Ⓢ]	LED1	Red LED	36 [Ⓢ]	ADC7	ADC CH7, JTAG TDI
11	RD	GPIO	37 [Ⓢ]	ADC6	ADC CH6, JTAG TDO
12	WR	GPIO	38 [Ⓢ]	ADC5	ADC CH5, JTAG
13	ALE	GPIO	39 [Ⓢ]	ADC4	ADC CH4, JTAG
14	PW7	GPIO	40	ADC3	GPIO/ADC CH3
15	USART1_CLK	USART1 Clock	41	ADC2	GPIO/ADC CH2
16 ^{ⓈⓈ}	PROG_MOSI	Serial Program MOSI	42	ADC1	GPIO/ADC CH1
17 ^{ⓈⓈ}	PROG_MISO	Serial Program MISO	43	ADC0	GPIO/ADC CH0
18 ^{ⓈⓈ}	SPI_CLK	SPI Serial Clock	44	THERM_PWR	Temp Sensor Enable
19	USART1_RXD	USART1 Receive	45	THRU1	Thru Connect 1
20	USART1_TXD	USART1 Transmit	46	THRU2	Thru Connect 2
21	I2C_CLK	I2C Bus Clock	47	THRU3	Thru Connect 3
22	I2C_DATA	I2C Bus Data	48 ^{ⓈⓈ}	RSTN	Reset (Neg.)
23	PWM0	GPIO/PWM0	49	PWM1B	GPIO/PWM1B
24	PWMIA	GPIO/PWM1A	50	VCC	Digital Supply
25	AC+	GPIO/AC+	51	GND	Ground
26	AC-	GPIO/AC-			

([Ⓢ] OK to use but has shared functionality. ^{ⓈⓈ} Do not use)

Table 11-3. MICA2 Sensor Interface.

Pin	Name	Description	Pin	Name	Description
1	GND	Ground	27 [Ⓢ]	UART_RXDO	UART Receive
2	VSNR	Voltage (battery)	28 [Ⓢ]	UART_TXDO	UART Transmit
3	INT3	GPIO	29	PWO	GPIO/PWM
4	INT2	GPIO	30	PW1	GPIO/PWM
5	INT1	GPIO	31	PW2	GPIO/PWM
6	INT0	GPIO	32	PW3	GPIO/PWM
7 [Ⓢ]	BAT_MON	Battery Voltage Monitor	33	PW4	GPIO/PWM
8 [Ⓢ]	LED3	Green LED	34	PW5	GPIO/PWM
9 [Ⓢ]	LED2	Yellow LED	35	PW6	GPIO/PWM
10 [Ⓢ]	LED1	Red LED	36 [Ⓢ]	ADC7	GPIO/ADC CH7, JTAG
11	RD	GPIO	37 [Ⓢ]	ADC6	GPIO/ADC CH6, JTAG
12	WR	GPIO	38 [Ⓢ]	ADC5	GPIO/ADC CH5, JTAG
13	ALE	GPIO	39 [Ⓢ]	ADC4	GPIO/ADC CH4, JTAG
14	PW7	GPIO	40	ADC3	GPIO/ADC CH3
15	USART_CLK	USART Clock	41	ADC2	GPIO/ADC CH2
16 ^{ⓈⓈ}	PROG_MOSI	Programmer Pin	42	ADC1	GPIO/ADC CH1
17 ^{ⓈⓈ}	PROG_MISO	Programmer Pin	43	ADC0	GPIO/ADC CH0
18 ^{ⓈⓈ}	SPI_CLK	Radio Clock	44	THERM_PWR	GPIO
19	USART1_RXD	USART1 Receive	45	THRU1	Thru User Connect
20	USART1_TXD	USART1 Transmit	46	THRU2	Thru User Connect
21	I2C_CLK	I2C Bus Clock	47	THRU3	Thru User Connect
22	I2C_DATA	I2C Bus Data	48 ^{ⓈⓈ}	RSTN	Micro Processor Reset
23	PWMIO	GPIO	49	PWM1B	GPIO
24	PWMIA	GPIO	50	VCC	Voltage (battery)
25	AC+	GPIO	51	GND	Ground
26	AC-	GPIO			

([Ⓢ] OK to use but has shared functionality. ^{ⓈⓈ} Do not use)

11.3 MICA2DOT Expansion Connector

The interface to the MPR500 is through a series of 19 pins Elpacko spaced around the circumference of the MPR5x0 Mote. (They represent a subset of the pins available on the MPR5x0.) They include a set of power control pins, ADC channels, power, ground, some general purpose digital IO, and the serial programming port. For applications with more digital IO, the ADC pins can be reconfigured as digital input/output but **not** both.

WARNING: The TP12 (SPI_CLK) pin is controlled by the Radio. In the majority of applications it should not be used. It is also used for programming the processor.

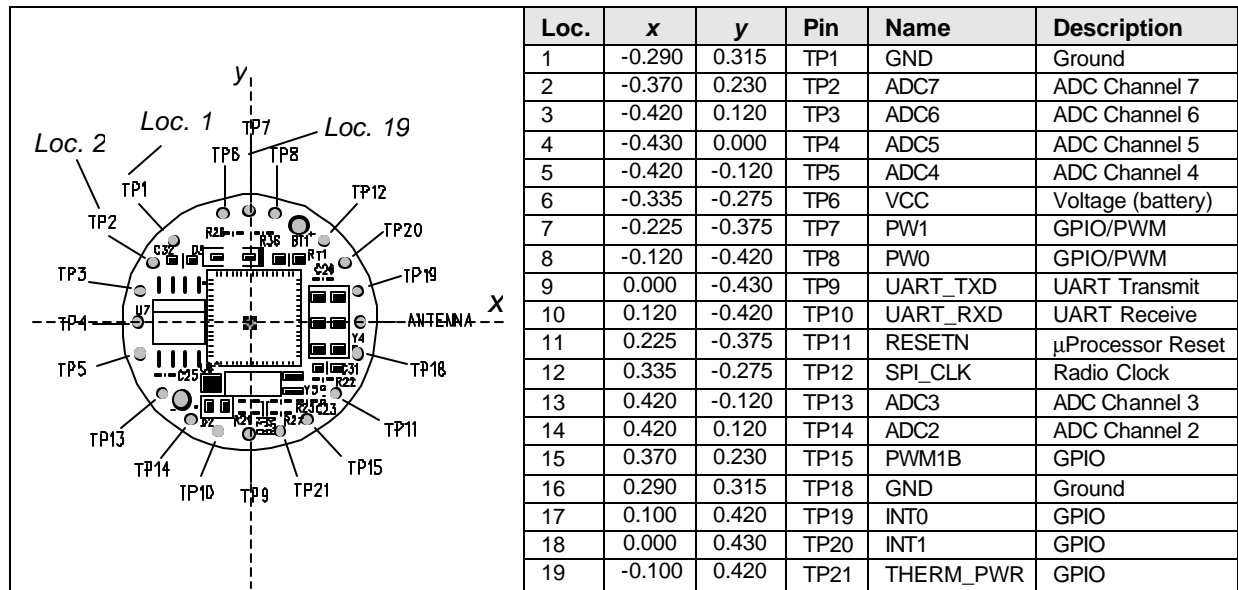

Figure 0-1. MICA2DOT pin locations and sensor interface description. The locations of the pins are taken relative to the geometric center of the board. The board has a diameter of 0.988 inches. Note the “TP” under the “Pin” column means “test point.”

12 MIB300 / MIB500 INTERFACE BOARDS

◀ **NOTE:** The MIB300 and MIB500 have been discontinued by Crossbow. The MIB500 has been replaced by the MIB510.

⚠ **WARNING:** When programming a MICA2 with the MIB500, turn off the battery switch. For a MICA2DOT, remove the battery before inserting into the MIB500. The MICA2s and MICA2DOTs do not have switching diodes to switch between external and battery power.

12.1 Programming the Mote

The MIB300/MIB500 interface boards are multi-purpose interface boards used in conjunction with the MICA Family of products. They supply power to the devices through an external power adapter option, and provide interfaces for an RS232 serial port and reprogramming port (using the parallel printer interface). The MIB300 can only be used with an external 3 VDC supply, or it can take advantage of the battery power supplied from the mote.

The MIB500 has an on-board regulator that will **accept 5 to 7 VDC**, and supplies a regulated 3 VDC to the MICA. The MIB500 is delivered with a wall power supply. It also has monitor LEDs that mirror the LEDs on the MICA.

There is a built-in low voltage monitor that disables reprogramming if the power supply voltage is dangerously low. When the proper programming voltage exists—the Green LED adjacent the parallel port is lit—D6. If the voltage goes below 2.95V, the Green LED D6 will turn off, programming is disabled.

The MIB500 also has an interface connector for reprogramming the MICA2DOT. Programming the mote is accomplished by connecting the MIB300/MIB500 to the parallel port of the computer, and executing the required programming software—UISP—supplied with the TinyOS install.

◀ **NOTE:** There have been numerous reported difficulties with programming motes through the MIB500CA. These include program failure, flash verification errors, and dead Motes. The root cause of these problems is almost always one of two issues: 1) low programming voltage or 2) UISP problems on the Host PC. A detailed application note is posted at <http://www.xbow.com> under Support. Please review this application note, if you have trouble programming. Programming the Motes improperly or with a bad UISP install can result in permanent damage to the Mote CPU.

12.2 RS-232 Interface

The RS-232 interface is a standard single channel bi-directional interface with a DB9 connector to interface to an external computer. It uses transmit and receive lines only.

13 MIB510 SERIAL INTERFACE BOARDS

◀ **NOTE:** The MIB510 will only work with ATmega128 processors used on the MICA2 and MICA2DOT. It will work for older Mica units that have the ATmega128 processor but not earlier processors such as the ATmega103.

13.1 Product Summary

The MIB510 interface board is a multi-purpose interface board used with the MICAz, MICA2, MICA, and MICA2DOT family of products. The board is supplied with all MOTE-KITs. It supplies power to the devices through an external power adapter option, and provides an interface for a RS-232 Mote serial port and reprogramming port.

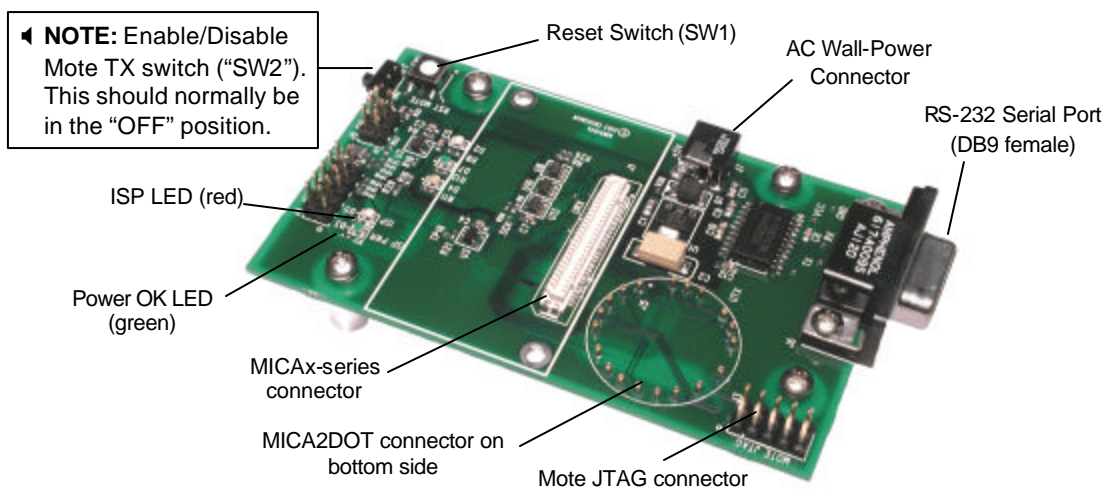



Fig 6.1 Photo of top view of an MIB510CA.

13.2 ISP

The MIB510 has an on-board in-system processor (ISP)—an Atmega16L located at U14—to program the Motes. Code is downloaded to the ISP through the RS-232 serial port. Next the ISP programs the code into the mote. The ISP and Mote share the same serial port. The ISP runs at a fixed baud rate of 115.2 kbaud. The ISP continually monitors incoming serial packets for a special multi-byte pattern. Once this pattern is detected it disables the Mote’s serial RX and TX, then takes control of the serial port.

 **WARNING:** Some USB to DB9 serial port adapters cannot run at 115 kbaud.

The ISP processor is connected to two LEDs, a green LED labeled “SP PWR” (at D3) and a red LED labeled “ISP” (at D5). SP PWR is used to indicate the power state of the MIB510 (see below). If the ISP LED is on, the MIB510 has control of the serial port. It will also blink once when the RESET (SW1) button is pushed and released.

13.3 Mote Programming Using the MIB510

Programming the Motes requires having TinyOS installed in your host PC. Instructions for installing TinyOS can be found in Crossbow’s *Getting Started Guide* or on-line at <http://www.tinyos.net/download.html>. The commands for downloading build (compiled) code

depend on the Mote platform you are programming. Instructions can also be found in the *Getting Started Guide*.

WARNING: Under Cygwin the ISP may not get control of the serial port if the Mote is continually sending packets over the serial TX line at a high rate. If this happens, the UISP will hang. This can be fixed by:

1. Type **Ctrl C** in the Cygwin window and try again.
2. Turn SW2 to the "ON" position. This turns on a circuit to disable the Mote's TX line. Be sure to set SW2 to 'OFF' after programming the mote if you are using the Mote as a base station (e.g., a MICAz or MICA2 Mote programmed with *Surge_Reliable* as node "0" or with *TOSBase*).

13.4 Interfaces to MICAz, MICA2, and MICA2DOT

The MIB510 has connectors for both the MICA2 and MICA2DOT. See the picture below. For the MICA2 there is another connector on the bottom side of the MIB510 for sensor boards. MICA2DOTs with battery connectors can be mounted, also, to the bottom side of the board.

13.4.1 Reset

The "RST MOTE" push button switch resets both the ISP and Mote processors. RST resets the ISP; after the ISP powers-up it resets the Mote's processor.

13.4.2 JTAG

The MIB510 has a connector, J3 ("MOTE JTAG") which connects to an Atmel JTAG pod for in-circuit debugging. This connector will supply power to the JTAG pod; no external power supply is required for the pod.

WARNING: The MIB510 also has JTAG and ISP connectors for the ISP processor. These are for factory use only.

13.4.3 Power

The MIB510 has an on-board regulator that will accept 5 to 7 VDC, and supply a regulated 3 VDC to the MICAz, MICA2, and MICA Motes. The MIB510 is delivered with a wall power supply.

WARNING: Applying more than 7 VDC will damage the on-board linear regulator.

There is a built-in low voltage monitor that disables reprogramming if the power supply voltage is dangerously low. When the proper programming voltage exists the "ISP PWR" LED is on. If the voltage goes below 2.9 V, the green "ISP PWR" LED will blink and disable the Mote from any code downloads. If the voltage is too low to power the ISP then the "ISP PWR" LED will be off.

WARNING: When programming a MICA2 with the MIB510, turn off the battery switch. For a MICA2DOT, remove the battery before inserting into the MIB510. The MICA2s and MICA2DOTs do not have switching diodes to switch between external and battery power.

13.4.4 RS-232 Interface

The RS-232 interface is a standard single channel bi-directional interface with a DB9 connector to interface to an external computer. It uses the transmit and receive lines only.



13.4.5 Schematics

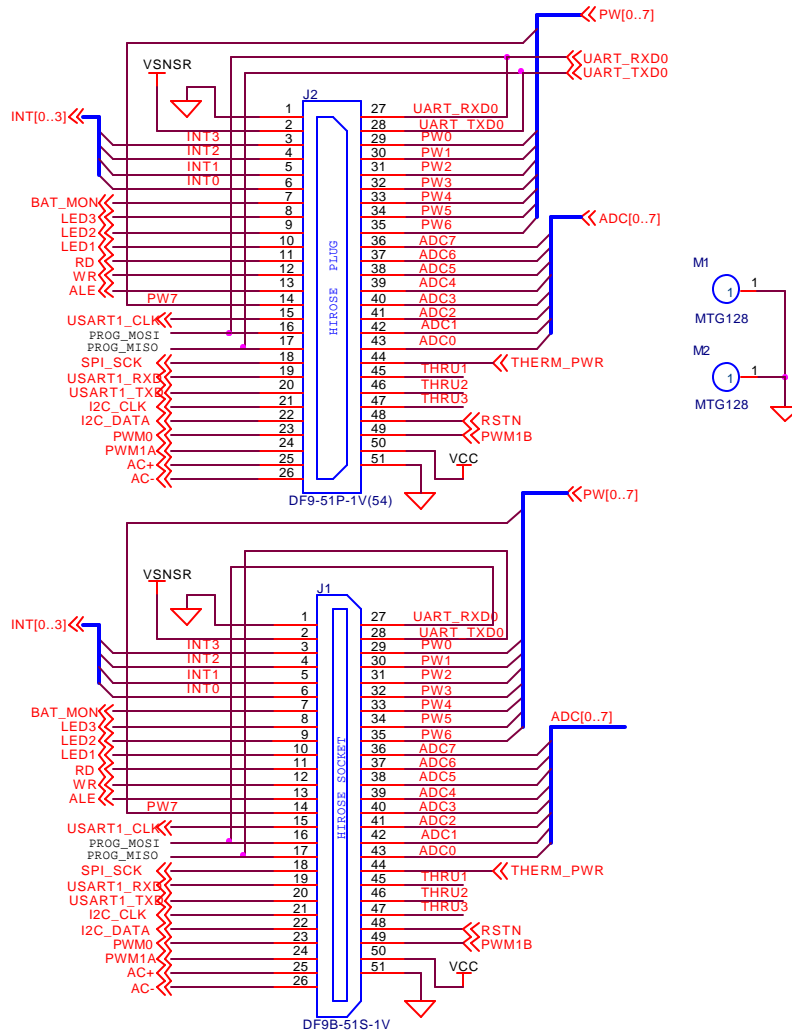

PIN	NAME	DESCRIPTION
1	GND	GROUND
2	VNSNR	SENSOR SUPPLY
3	INT3	GPIO
4	INT2	GPIO
5	INT1	GPIO
6	INT0	GPIO
7	BAT_MON	BATTERY VOLTAGE MONITOR ENABLE
8	LED3	LED3
9	LED2	LED2
10	LED1	LED1
11	RD	GPIO
12	WR	GPIO
13	ALE	GPIO
14	PW7	POWER CONTROL 7
15	USART1_CLK	USART1 CLOCK
16	PROG_MOSI	SERIAL PROGRAM MOSI
17	PROG_MISO	SERIAL PROGRAM MISO
18	SPI_SCK	SPI SERIAL CLOCK
19	USART1_RXD	USART1 RX DATA
20	USART1_TXD	USART1 TX DATA
21	I2C_CLK	I2C BUS CLOCK
22	I2C_DATA	I2C BUS DATA
23	PWM0	GPIO/PWM0
24	PWM1A	GPIO/PWM1A
25	AC+	GPIO/AC+
26	AC-	GPIO/AC-

PIN	NAME	DESCRIPTION
27	UART_RXD0	UART_0 RECEIVE
28	UART_TXD0	UART_0 TRANSMIT
29	PW0	POWER CONTROL 0
30	PW1	POWER CONTROL 1
31	PW2	POWER CONTROL 2
32	PW3	POWER CONTROL 3
33	PW4	POWER CONTROL 4
34	PW5	POWER CONTROL 5
35	PW6	POWER CONTROL 6
36	ADC7	ADC INPUT 7 - BATTERY MONITOR/JTAG TDI
37	ADC6	ADC INPUT 6 / JTAG TDO
38	ADC5	ADC INPUT 5 / JTAG TMS
39	ADC4	ADC INPUT 4 / JTAG TCK
40	ADC3	ADC INPUT 3
41	ADC2	ADC INPUT 2
42	ADC1	ADC INPUT 1
43	ADC0	ADC INPUT 0 / RSSI MONITOR
44	THERM_PWR	TEMP SENSOR ENABLE
45	THRU1	THRU CONNECT 1
46	THRU2	THRU CONNECT 2
47	THRU3	THRU CONNECT3
48	RSTN	RESET (NEG)
49	PWM1B	GPIO/PWM1B
50	VCC	DIGITAL SUPPLY
51	GND	GROUND

13.4.6 RS-232, MICA2DOT, and Ext. Power Interface.

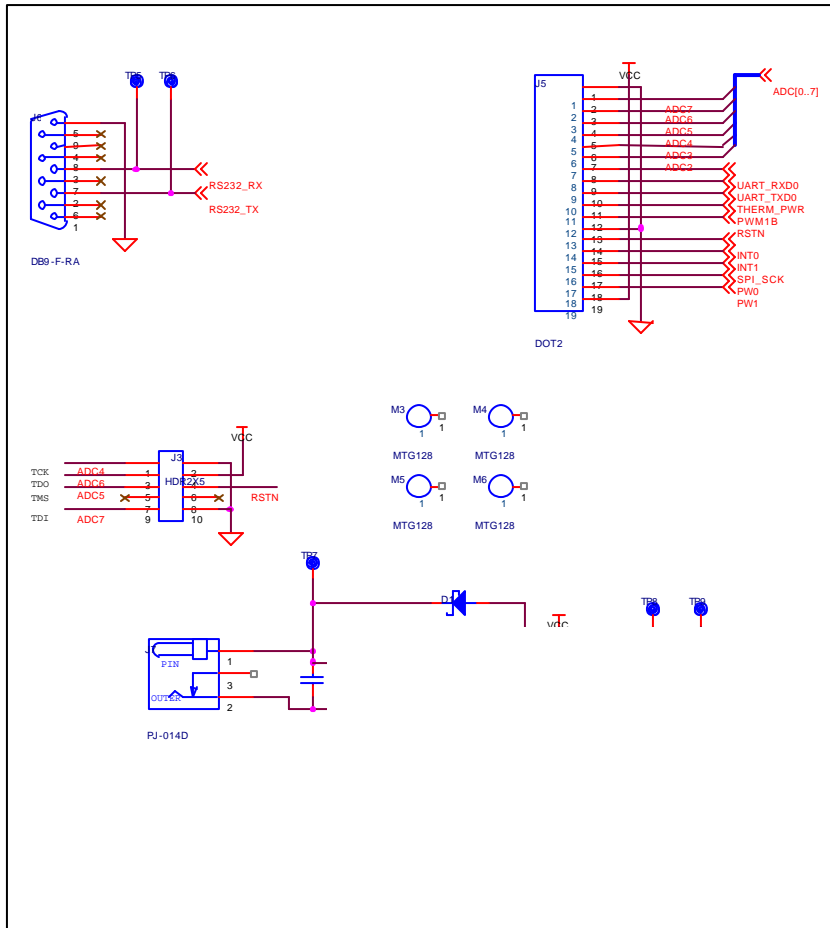

14 MIB600CA

14.1 Introduction

The MIB600CA provides Ethernet (10/100 Base-T) connectivity to MICA2 family Motes for communication and in-system programming. Its two standard configurations are a) an Ethernet Gateway for a Mote network and b) a Mote network programming and out-band diagnostic channel.

The MIB600CA device contains, on a 4.5" × 2.25" platform a

- ❑ MICA2 mote 54-pin connector (J1),
- ❑ Mote target JTAG port (J12),
- ❑ TCP/IP serial server,
- ❑ In-system programmer compatible with UISP STK500,
- ❑ On-board power regulation and monitor, and a
- ❑ Power Over Ethernet (POE) power supply

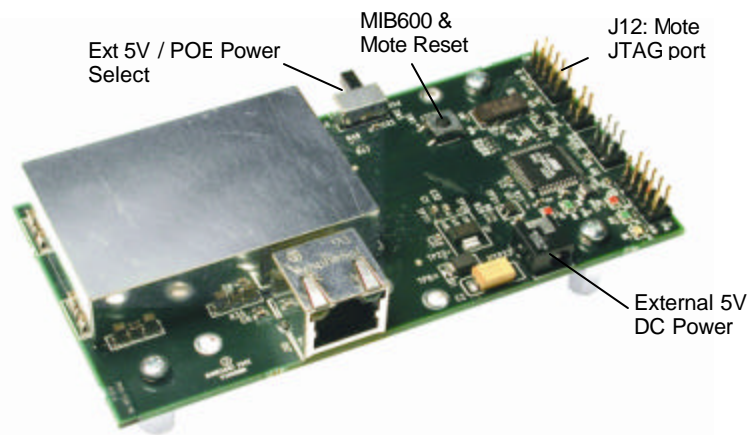

Figure 14-1. Photo of top side of an MIB600CA.

14.1.1 Mote Network – Ethernet Gateway

A MICAz or MICA2 Mote running *TOSBase* or *GenericBase* is permanently installed on the MIB600. This forms a Mote RF to Ethernet bridge.

14.1.2 Mote Network Programming and Out-Band Diagnostic Channel

The MICAz and MICA2 Motes connect to the MIB600 for UISP programming from LAN connected host computers. Out band (non-RF) diagnostics can be forwarded from the Mote via its UART port over the LAN to host monitor/control computers.

14.2 Setup / Installation

This section describes MIB600 installation and configuration for use in a TinyOS v1.1 environment.

14.2.1 Physical

For other than temporary installations, the MIB600 should be installed in a ground isolated enclosure.

14.2.2 MICA Mote Connection

MICAZ and MICA2 Motes connect to the MIB600 directly via the standard mote 51-pin HIROSE connector at J1. Two mounting holes are provided for securing the MICA2 Mote when installed at J1. It is recommended that these mounting points be used for longer term installations to ensure a reliable mechanical and electrical connection to the MIB600.

14.2.3 Power

Two power supply sources are available with the MIB600

- External 5VDC from AC wall-power adaptor
- Power Over Ethernet

External 5VDC Power Supply

- Connect the external 5VDC power supply to an AC 110-240V power source.
- Place the MIB600 SW2 in the POE position
- Connect the DC plug to J7 of the MIB600

◀ **NOTE:** Turn-on the MIB by placing the SW2 in the 5V position. Turn-off by placing the SW2 in the POE position.

Power Over Ethernet / IEEE802.3af (POE).

⚠ **WARNING!** The Mote “ground” is at POE potential (-48 V). Do not connect MIB600 to facility/building ground when using POE.

An IEEE 802.3af compliant power supply is provided for POE equipped facilities. Ethernet appliance power (-48 V) is supplied at pins 4/5 and 7/8 of the 10/100 Base-T RJ45 plug. Refer to Appendix A for Base-T wiring information.

The MIB600 POE circuit contains IEEE 802.13f compliant power sequencing and classification circuitry. Reversed and over-voltage protection is provided.

◀ **NOTE:** The MIB600 only supports POE over the “spare wires” 4/5 and 7/8. It does not support POE shared on the Base-T signaling lines.

- Connect the MIB600 to a POE-equipped LAN port.
- Turn-On the MIB600 by placing the MIB600 SW2 in the POE position
- Turn-Off by placing SW2 in 5V position (with External 5VDC supply disconnected)

14.2.4 MIB600–LAN Connection

The MIB600 Serial Server connects directly to a 10 Base-T LAN as any other network device. Straight cables are used to connect to a hub or switch. If your connection is an MIB600 to PC you **must** use a crossed cable. Refer to Appendix A for LAN wiring information.

**Table 14-2.** Pin Outs for a LAN Connection

Pin No.	Strand Color	Name
1	white and orange	TX+
2	orange	TX-
3	white and green	RX+
4	blue	0V POE
5	White and blue	0V POE
6	green	RX-
7	Brown and white	-48V POE
8	Brown	-48V POE

14.3 Host Software

14.3.1 UISP

UISP version 20030820tinyos or newer is required. This version is included in the TinyOS 1.1.0 September 2003 release package. Verify your system is using a compatible UISP version by entering `uisp --version` in a Cygwin window (see the example below in Figure 14-3).

```

/cygdrive/c/tinyos-1.x/apps/genericbase
$ uisp --version
uisp version 20030820tinyos
<C> 1997-1999 Uros Platisic, 2000-2003 Marek Michalkiewicz
<C> 2003 Philip Buonadonna, Intel Corporation
<C> 2003          Crossbow Technology

uisp is free software, covered by the GNU General Public License.
You are welcome to change it and/or distribute copies of it under
the conditions of the GNU General Public License.

```

Figure 14-3. Screen shot of the output after typing in `uisp --version`.

14.4 MIB600 Use

14.4.1 Controls and Indicators

Power. MIB600 power (and power to attached mote) is controlled by the switch labeled “SW2.”

WARNING! Always turn-off the MIB600's power before installing/removing a mote.

Table 14-5. SW2 Switch Settings.

Position	Function
5V	External 5V DC power supply selected
POE	Power Over Ethernet supply selected

When valid power is detected, the green LED at D5 is ON.

LAN Activity Indicators (RJ45). green indicates a network connection is present. Yellow indicates Active ISP serial port traffic is present.

RESET. Pressing the RESET pushbutton (SW1) causes the MIB600 and any installed/attached MOTE to reset. Note the Serial Server is NOT reset.

Serial Server RESET. Pressing the S1 switch on the server sub-module (U15) manually resets the Ethernet serial server.

◀**NOTE** The MIB600 and attached Mote are not reset. The serial server can also be reset via Telnet at Port 9999.

ISP LED. During in-system programming of a Mote the ISP LED (D3) is ON.

Mote LEDs. Three LEDs (red, green, yellow) correspond to the attached Mote's indicators.

14.4.2 Mote UART (Serial Port)

The Mote's serial port can be accessed via Telnet using Port# 10002.

Factory default serial rate on the Serial Server is 57.6 kbaud for compatibility with the standard TinyOS v1.1 release of *TOSBase & GenericBase*.

If other baud rates or communication parameters are used in your Mote application, the serial server configuration must be changed.

14.4.3 In-System Programming

The MIB600 ISP micro-controller is attached to Port#10002. UISP assumes this port assignment by default. Programming using MIB600 requires assigning an IP address to the device first followed by commands via Cygwin. Instructions can be found in Crossbow's Getting Started Guide.

14.5 JTAG

JTAG connection to the attached MICAz/MICA2 Mote is via J12. Note PIN1 orientation (square pad) is indicated by the J12 legend. Power for the JTAG pod is provided by the MIB600 at J12 pin 4. Please use the tables in this section as references when using the JTAG connection. Table 14-6 has information about the controls, indicators, and connector summary; Table 14-7 has information on the JT12 Mote JTAG pins.

Table 14-6. Controls, Indicators, and Connector Summary.

ID	NAME	DESCRIPTION
CONTROLS		
SW1	RESET	MIB600 Manual RESET pushbutton. Resets MIB600 ISP controller and attached MOTE.
SW2	POWER SELECT	
	5V	Selects External 5VDC power source at J7
	POE	Selects Power Over Ethernet provided at RJ45/J10
	Serial Server Reset	Reset Serial Server. Located on Server sub module U15
CONNECTORS		
J1	MOTE I/O 51	Standard 51 Position MICAx-series Mote interface
J7	External 5VDC Input	Connects to external 5VDC +/-20% power supply
J9	JTAG-ISP	JTAG connection to MIB600 ISP Controller. For Factory Test only
J10	RJ45 / LAN	Ethernet 10Base-T connection (w/ IEEE 802.3af option)
J11	MOTE Umbilical	Umbilical connection to Mote Adapter PCB. Used for connection to MICA2 and MICA2DOT motes.
J12	JTAG-MOTE	JTAG connection to attached MICA2/MICA2DOT Mote. Provides JTAG connectivity between external JTAG pod and Mote.
	COM1	Factory use only. Do not use
INDICATORS		
D2	MOTE-YELLOW	Corresponds to attached Mote's Yellow LED
D4	MOTE-RED	Corresponds to attached Mote's Red LED
D7	MOTE-GREEN	Corresponds to attached Mote's Green LED
D3	ISP Active	Indicates MIB600 in PROGRAMMING mode – RED
D5	Power OK	Indicated MIB600 input power is OK









Table 14-7. J12 Mote JTAG

PIN	NAME	DESCRIPTION
1	TCK/ADC4	MICA2(DOT) JTAG Clock
2	GND	Ground
3	TDO	MICA2(DOT) JTAG Data Out
4	VCC	3.3V Power
5	TMS	MICA2 (DOT) JTAG Sync
6	RSTN	MICA2 (DOT) Reset
7	VCC	3.3V Power to JTAG Pod
8	N/C	Not connected
9	TDI	MICA2(DOT) JTAG Data In
10	GND	Ground









15 APPENDIX A: 10/100 BASE-T CABLING

Category 5(e) (UTP) color coding table

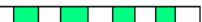
TIA/EIA 568A Wiring

1		White and Green
2		Green
3		White and Orange
4		Blue
5		White and Blue
6		Orange
7		White and Brown
8		Brown

TIA/EIA 568B Wiring

1		White and Orange
2		Orange
3		White and Green
4		Blue
5		White and Blue
6		Green
7		White and Brown
8		Brown

EIA/TIA 568A

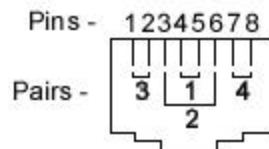

- Pin Colours
- 1 White and Green
 - 2 Green
 - 3 White and Orange
 - 4 Blue
 - 5 White and Blue
 - 6 Orange
 - 7 White and Brown
 - 8 Brown

EIA/TIA 568B

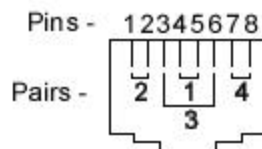

- Pin Colours
- 1 White and Orange
 - 2 Orange
 - 3 White and Green
 - 4 Blue
 - 5 White and Blue
 - 6 Green
 - 7 White and Brown
 - 8 Brown

16 WARRANTY AND SUPPORT INFORMATION

16.1 Customer Service

As a Crossbow Technology customer you have access to product support services, which include:

- Single-point return service
- Web-based support service
- Same day troubleshooting assistance
- Worldwide Crossbow representation
- Onsite and factory training available
- Preventative maintenance and repair programs
- Installation assistance available

16.2 Contact Directory

- United States: Phone: +1 408 965 3300 (8 AM to 5 PM PST)
- Fax: +1 408 324 4840 (24 hours)
- Email: techsupport@xbow.com
- FAQ Site: www.xbow.com > Support>Technical Support (FAQ Site)
- Non-U.S.: Refer to website www.xbow.com and/or the FAQ site above.

16.3 Return Procedure

16.3.1 Return Policy

Customer may return unwanted product within thirty (30) days of Delivery Date. Customer shall pay a twenty percent (20%) restocking charge on any unwanted products returned to Crossbow. **No returns will be accepted after the thirty (30) day period has expired.** Where special equipment or services are involved, Customer shall be responsible for all related work in progress; however, Crossbow shall take responsible steps to mitigate damages immediately upon receipt of a written cancellation notice from Customer. An RMA number must be obtained from Crossbow for any return of product. Crossbow may terminate any order if any representations made by Customer to Crossbow are false or misleading.

16.3.2 Authorization

Before returning any equipment, please contact Crossbow to obtain a Returned Material Authorization number (RMA).

Be ready to provide the following information when requesting a RMA:

- Name
- Address
- Telephone, Fax, Email
- Equipment Model Number
- Equipment Serial Number
- Installation Date
- Failure Date
- Fault Description

16.3.3 Identification and Protection

If the equipment is to be shipped to Crossbow for service or repair, please attach a tag TO THE EQUIPMENT, as well as the shipping container(s), identifying the owner. Also indicate the service or repair required, the problems encountered, and other information considered valuable to the service facility such as the list of information provided to request the RMA number.

Place the equipment in the original shipping container(s), making sure there is adequate packing around all sides of the equipment. If the original shipping containers were discarded, use heavy boxes with adequate padding and protection.

16.3.4 Sealing the Container

Seal the shipping container(s) with heavy tape or metal bands strong enough to handle the weight of the equipment and the container.

16.3.5 Marking

Please write the words, "**FRAGILE, DELICATE INSTRUMENT**" in several places on the outside of the shipping container(s). In all correspondence, please refer to the equipment by the model number, the serial number, and the RMA number.

16.3.6 Return Shipping Address

Use the following address for all returned products:

Crossbow Technology, Inc.
41 Daggett Drive
San Jose, CA 95134
Attn: RMA Number (XXXXXX)

16.4 Warranty

The Crossbow product warranty is one year from date of shipment.



Crossbow Technology, Inc.
41 Daggett Drive
San Jose, CA 95134
Phone: +1 408 965 3300
Fax: +1 408 324 4840
Email: info@xbow.com