

CROWN

Specifications

SC 4500 Series

Sit-down Rider
Lift Truck

SC 4500

Series



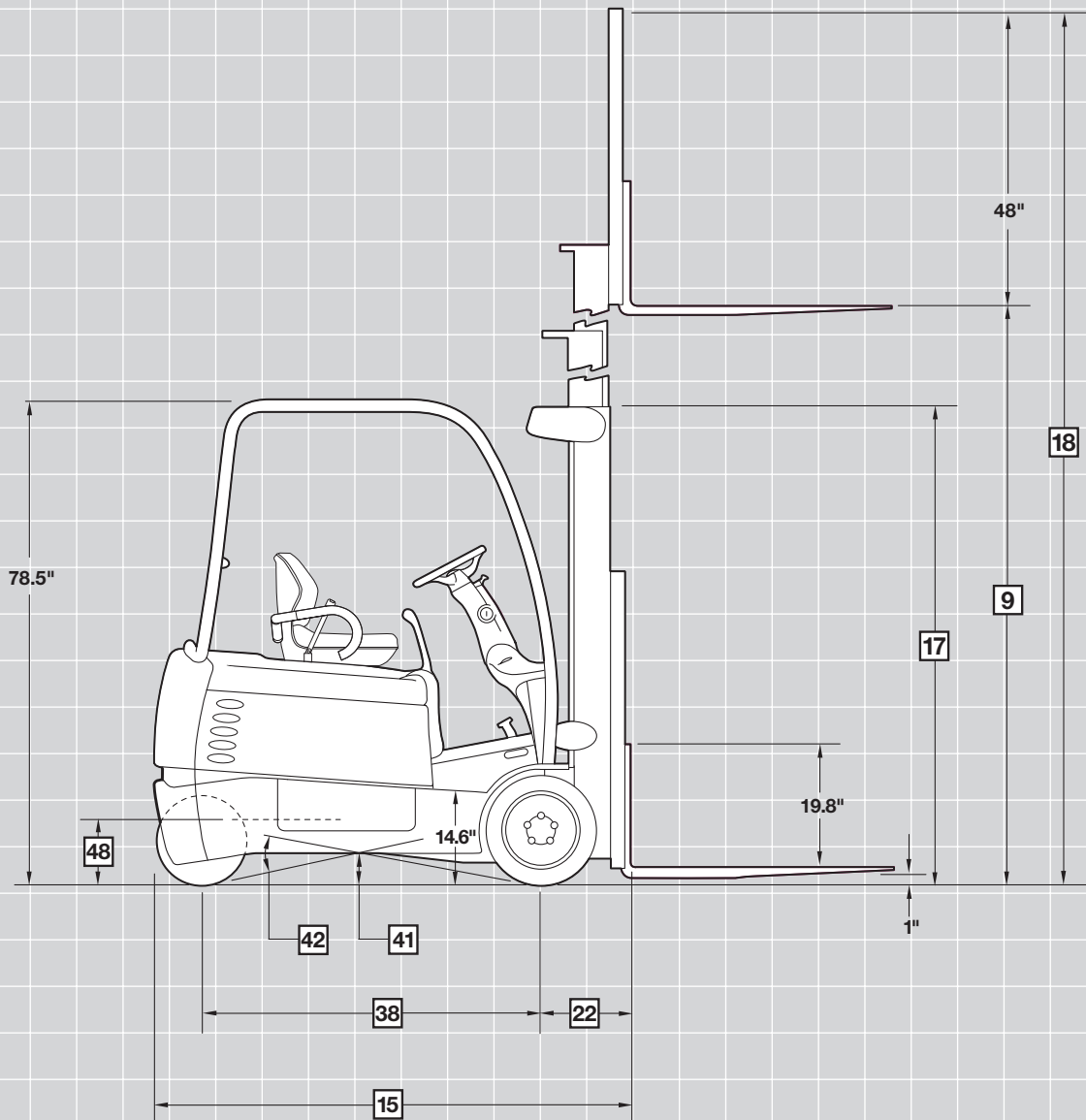
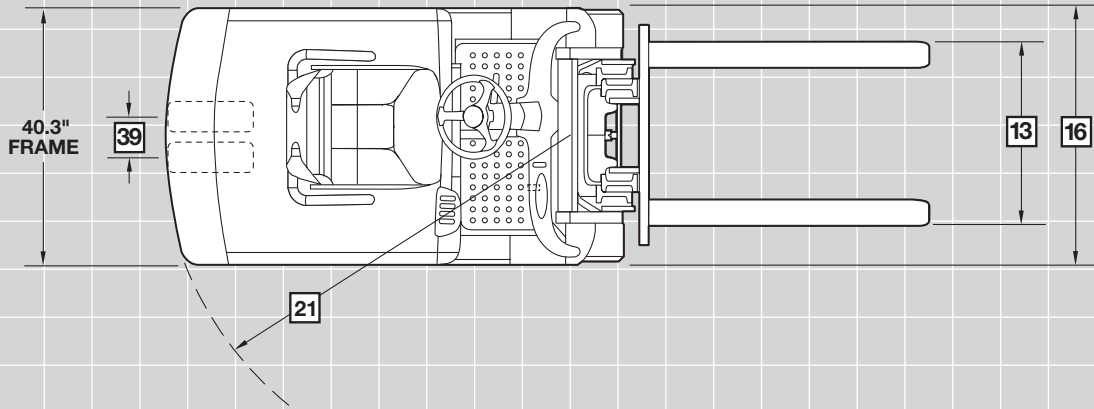

		Crown Equipment Corporation							
		4510-30	4520-30	4520-35	4540-35	4540-40			
General Information	1	Manufacturer	Crown Equipment Corporation						
	2	Model	SC	4510-30	4520-30	4520-35	4540-35	4540-40	
	3	Load Capacity*	Rated to 154 in	lb	3000	3000	3500	3500	4000
	4	Load Center	Fork Face to Load CG	in	24				
	5	Power	Electric						
	6	Operator Type	Sit-down Rider						
	7	Tire Type	Press-on Solid						
	8	Wheels (x = driven)	Number Front/Rear						
Dimensions	9	Mast**	Lifting Height	in	190				
	11		Free Lift Height†	in	35				
	12	Fork Carriage	ITA Class II						
	13	Forks†††	Standard L x W x T	in	36 x 4 x 1.5	36 x 4 x 1.5	36 x 4 x 1.75	36 x 4 x 1.75	36 x 4 x 1.75
			Optional Lengths	in	30, 39, 42, 45, 48, 54, 60				
			Fork Spread–Min/Max		9/33	9/33	9/33	9/33	9.5/36
	14	Tilt	B°/F°	degree	5 / 5				
	15	Headlength		in	67.9***	72.4***	72.6***	77.2***	77.2***
	16	Width Overall†††	Standard Tread	in	40.3	40.3	40.3	40.3	42.3
	17	Height	Mast Collapsed	in	83				
			Mast Extended†	in	238				
	21	Turning Radius		in	53.6	58.1	58.1	62.7	62.7
	22	Load Distance	Center of Wheel to Fork Face	in	14.3***		14.5***		
	23	Aisle Width	Right Angle Stack	in	Turn Radius + Load Distance + Load Length + Clearance				
Speeds	24	Speed Travel††	Empty/Loaded	36V mph	8.5/7.6	8.5/7.6	8.5/7.5	8.5/7.5	8.5/7.2
	25	Speed Lift††	Empty/Loaded	36V fpm	90/63	90/63	90/60	90/60	90/58
	26	Speed Lower	Empty/Loaded	fpm	90/90	90/90	90/90	90/90	90/90
Weights	32	Weight, Less Battery		lb	6149	5974	6216	6040	6260
	33	Axle Load with Max Battery	Unloaded Front	lb	4047	4300	4316	4518	4506
			Unloaded Rear	lb	3852	3924	4150	4122	4355
Chassis	35	Tires	Number Front/Rear		2 / 2				
	36		Size Front	in	18x7x12.1	18x7x12.1	18x7x12.1	18x7x12.1	18x8x12.1
	37		Size Rear	in	15 x 5 x 11.25				
	38	Wheelbase		in	45.6	50.1	50.1	54.7	54.7
	39	Tread Width	Front	in	33.3	33.3	33.3	33.3	34.3
			Rear	in	6.7				
	40	Ground Clearance, Loaded	Lowest Point	in	3.0				
	41		Center of Wheelbase	in	4.8	5.0	5.0	5.0	5.0
	42	Grade Clearance, Loaded		%	27.1	24.6	24.6	22.4	22.4
	43	Brakes	Service		Foot - Motor / Electric Assist				
44		Parking		Auto - Electric					
Battery	45	Battery	Type		Lead Acid				
			Capacity	AH	510	680	680	850	850
			KWH	17.8	23.7	23.7	29.6	29.6	
	47		Weight - Min	lb	1475	1850	1850	2250	2250
			Weight - Max	lb	1750	2250	2250	2600	2600
			Size - Max	Length	16.01	20.50	20.50	24.88	24.88
				Width	38.81				
			Height	22.80					
48	Battery Floor Height	With Rollers / w/o Rollers	in	10.4/9.8					
Motors	49	Motors	Traction Motor, dia	in	7.5				
	50		Lift Motor, dia	in	6.7				
	51	Operating Pressure	For Attachments	psi	Up to 3100 psi				

* Optional masts, attachments, longer load dimensions and higher lifting heights may result in derating of the capacity. Contact your local dealer.

** Other mast heights available. See chart for other standard mast heights.

*** Add 4.25 inches for quad masts.

† Includes load backrest.

†† Performance specifications are based on a truck equipped with a 190" triple telescopic mast.

††† Wide tread standard on 4000 lb model, trucks equipped with quad mast or TT mast collapsed height above 89".

Fork spread is 36" with wide tread.

Mast Chart SC 4500 Series			TT					QUAD				
9	Lifting Height	in	172	190	208	226	241	240	246	258	264	276
11	Free Lift Height*	in	29	35	41	47	52	36	38	41	44	47
14	Tilt B/F	degree	5/5	5/5	5/5	3/5	3/5	5/5**	5/5**	5/5**	5/5**	5/5**
17	Mast Collapsed Height	in	77	83	89	95	100	83	86	89	92	95
18	Mast Extended Height*	in	220.5	238.5	256.5	274.5	289.5	288	294	306	312	324

* Includes load backrest.

** Not available with drive-in rack or double-function hydraulics.

SC 4500 Series

Technical Information

Standard Equipment

- Crown's Access 1 2 3® Comprehensive System Control
- e-GEN™ Braking System with automatic parking brake
- Intrinsic Stability System
 - Travel speed reduction and appropriate brake control when forks are above free lift
 - Forward tilt interlock above free lift
 - Controlled tilt speeds
 - Counterweight exceeds required standards
 - Cornering speed control
 - Ramp hold
 - Ramp speed control
- 36-volt system
- Driveability standard features
 - 15" step height
 - Large, uncluttered floorboard
 - Rubber floor mat
 - Rubber accelerator and brake pedal
 - Large, entry/exit "window"
 - Contoured battery cover for easy entry/exit
 - Full suspension seat with anti-cinch seat belt and hip restraint
 - Compact steering wheel and steering column
 - Infinitely adjustable tilt steering
 - Operator forward design for enhanced visibility
 - Low cowl for fork and floor visibility
 - Urethane covered control handles with tactile feedback
 - Natural position for forward/reverse selector
 - Automatic parking brake

- Crown display
 - Battery discharge indicator with lift interrupt and re-key feature
 - Hour meters / travel distance / stop watch
 - Pin code access capable
 - Event code display with five (5) key navigation
 - Access 1 2 3 diagnostics
 - P1, P2, P3 Performance tuning
- 350 amp battery connector
- InfoPoint® System with Quick Reference Guide
- Color-coded wiring
- Lift out or side removal battery access
- Dual 15" steer tires
- Large 18" cushion drive tires
- Crown-manufactured drive and lift motors
- Proportional rack and pinion steering
- Waterfall design overhead guard
- 48" high load backrest
- No tool lift out floorboards for service access
- High visibility mast with in-line hose routing
- O-ring face seal hydraulic fittings
- 5° Forward / 5° Back tilt

Optional Equipment

- Battery rollers
- Shoulder seat restraint
- Freezer and corrosion conditioning
- Sideshifter
- Hydraulic valves for attachments
- Quick disconnect hydraulic connectors
- Steering spinner knob
- Storage tray

- Keyless on/off switch
- Fork lengths
- Polished and tapered forks
- Load backrest heights
- Non-marking smooth or lug rubber tires
- Drive-in rack overhead guard
- Tilt options
- Working lights
- Flashing lights
- Brake, tail and back-up light
- Audible travel alarms
- Tilt position assist
- Arm rest
- Work Assist™ Accessories
 - Clip pad and hook
 - Clamp
 - Clamp and mounting plate
 - Operator fan
 - Fire extinguisher
 - Mirrors

Driveability

The SC 4500 Series benefits from Crown's design and engineering excellence. Numerous design features improve operator comfort and productivity.

A low 15" step height first greets the operator. A low battery cover that is streamlined helps the operator glide into the truck's full suspension seat. The overhead guard is shaped to open up the entry/exit window. The compact tilt steer column and steer wheel further facilitate entry/exit. Floorboards are large, uncluttered and rubber covered to insulate the operator from vibration. Brake and accelerator pedals are rubber covered to provide good grip and comfort.

Several designs contribute to better visibility everywhere you look. A low cowl for fork visibility, a unique waterfall overhead guard for load handling, a high visibility mast and a compact steer column all improve operator visibility around the truck.

Control handles are crafted into the compartment and "fanned" for easy selection. They are urethane covered with tactile feedback for comfort and easy selection. Control actuation forces are minimal and responsive.

Crown Drive System

Crown has applied the latest generation AC drive system, enhanced with Access 1 2 3 technology. The demand for high efficiency systems that closely match customer torque requirements is met with this generation control system. Crown-manufactured, independently controlled, AC drive motors are specifically designed to optimize system integration between the traction and braking controls.

Crown's Access 1 2 3 technology provides optimum performance and control by offering a communication interface for operators and technicians, intelligent coordination of lift truck system and simplified service with advanced diagnostics.

The Crown display is used for easy troubleshooting, access service history and set performance features. A distribution panel is conveniently located with all test points, control fuses and central wiring for easy troubleshooting.

Three modes of performance can be selected to accommodate operator experience or application requirements.

e-GEN™ Braking System

Variable regenerative motor braking is optimized and assisted with electric friction brakes, eliminating maintenance associated with typical wet, disk or drum and shoe style brakes. The appropriate amount of stopping force is applied to match operator brake input and the current operating conditions of the truck.

The closed loop Access 1 2 3 traction control will keep the truck static until a travel input is requested, even when operating on a grade.

Automatic electric parking brakes activate when the operator leaves the seat, a travel input has not been requested or battery power has been disconnected.

Proportional Rack and Pinion Steering System

Hydrostatic power steering uses a large, totally enclosed rack and pinion gear assembly.

The steering geometry is matched to the controller to deliver smooth steering at all angles. The advantage is less tire scrubbing which extends tire life.

Both motors receive power, even in the tightest turns. This helps the truck to accelerate, turn and maneuver even from a full turn start position.

Cornering speed control regulates the drive motor's output by the turning degree of the truck. The advantage is smooth, stable steering which may increase operator confidence and productivity.

Large, (15" diameter) dual steer wheels provide good traction and stability.

Hydraulics

The hydraulic system provides continuous filtration. A heat stabilized polymer hydraulic tank is free from contamination and retains strength over a wide range of temperatures. Hydraulic attachments can be added easily in the field using modular valve bodies. Hydraulic valve handle actuation is precise and oil is controlled using metered spool valves.

Ram displacement type lift cylinders and two double acting tilt cylinders are Crown-manufactured. All rams and piston rods are hard chrome plated to reduce pitting and extend cylinder packing life. O-ring face seal fittings are used to eliminate leaks.

Mast Assembly

Crown-manufactured mast assembly utilizes a "flush-face" interlocked I-beam design to improve visibility and save truck length. Roller bearing studs are welded on both sides of the rails for maximum strength and roller bearings are canted to run in the thick cross section of the rail. Tie bars wrap around the rails for added strength and to resist off-center load forces.

"In-line" hose routing opens up visibility. Cylinders are placed to the sides to create a high visibility design.

The mast has four points of attachment to the truck for good load force distribution. Two mounting points are at the frame, where tilt cylinders attach. Tilt cylinders use spherical bushings to resist off center load distortions. Two large diameter trunnions secure the mast to the drive units.

Drive Units

Two independent double reduction gear drives offer 22.5 to 1 gear reduction. The first reduction uses spiral bevel gears for low noise and efficiency. The second reduction uses helical gears. The drive unit gears are constantly lubricated in an oil bath.

This time proven design is quiet and reliable, providing years of trouble-free service.

Carriage

An ITA Class II carriage is standard. An optional hook type ITA sideshifter or other attachments are easily added. Optional fork lengths are available.

Other Options

1. Audible travel alarm
2. Flashing lights

Safety considerations and dangers associated with audible travel alarms and flashing lights include:

- Multiple alarms and/or lights can cause confusion.
- Workers ignore the alarms and/or lights after day-in and day-out exposure.
- Operator may transfer the responsibility for "looking out" to the pedestrians.
- Annoys operators and pedestrians.

Other Options Available

Contact your local Crown dealer.

Dimensions and performance data given may vary due to manufacturing tolerances. Performance is based on an average size vehicle and is affected by weight, condition of truck, how it is equipped and the conditions of the operating area. Crown products and specifications are subject to change without notice.



Crown Equipment Corporation
New Bremen, Ohio 45869 USA
Tel 419-629-2311
Fax 419-629-3796
crown.com

Because Crown is continually improving its products,
specifications are subject to change without notice.

Crown, the Crown logo, the Momentum symbol,
Access 1 2 3, InfoPoint, e-GEN and Work Assist are
trademarks of Crown Equipment Corporation.

Copyright 2006 Crown Equipment Corporation
SF14690 9/06
Printed in U.S.A.