

Cadet®

Operator's Manual



Riding Mower Internal Bagging System

Model 1027
(13A-328-101)

IMPORTANT: Read safety rules and instructions carefully before operating equipment.

Warning: This unit is equipped with an internal combustion engine and should not be used on or near any unimproved forest-covered, brush-covered or grass-covered land unless the engine's exhaust system is equipped with a spark arrester meeting applicable local or state laws (if any). If a spark arrester is used, it should be maintained in effective working order by the operator. In the State of California the above is required by law (Section 4442 of the California Public Resources Code). Other states may have similar laws. Federal laws apply on federal lands. A spark arrester for the muffler is available through your nearest engine authorized service dealer or contact the service department, P.O. Box 368023 Cleveland, Ohio 44136-9722.

CUB CADET CORP. P.O. BOX 368023 CLEVELAND, OHIO 44136-9722

PRINTED IN U.S.A.

FORM NO. 770-10094B
(12/99)

TABLE OF CONTENTS

Content	Page
Important Safe Operation Practices.....	3
Slope Gauge.....	6
Assembling Your Riding Mower.....	7
Know Your Riding Mower.....	9
Operating Your Riding Mower.....	11
Making Adjustments.....	13
Servicing Your Rider Mower.....	15
Maintaining Your Riding Mower.....	17
Off-Season Storage.....	19
Troubleshooting.....	20
Parts List.....	22

FINDING MODEL NUMBER

This Operator's Manual is an important part of your new riding mower. It will help you assemble, prepare and maintain the unit for best performance. Please read and understand what it says.



Before you start assembling your new equipment, please locate the model plate on the equipment and copy the information from it in the space provided below. The information on the model plate is very important if you need help from our Customer Dealer Referral line.

- You can locate the model plate by pivoting the cover upward and looking under the frame. A sample model plate is explained below. For future reference, please copy the model number and the serial number of the equipment in the space below.

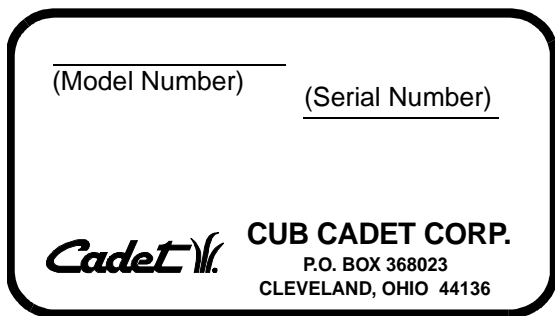

Copy the model number here: _____

Copy the serial number here: _____

CALLING CUSTOMER SUPPORT

If you have difficulty assembling this product or have any questions regarding the controls, operation or maintenance of this unit, please call the Customer Dealer Referral Line.



Call **1- (800)-528-1009** to reach a Customer Support representative. Please have your unit's model number and serial number ready when you call. See previous section to locate this information. You will be asked to enter the serial number in order to process your call .

SECTION 1: IMPORTANT SAFE OPERATION PRACTICES



This symbol points out important safety instructions which, if not followed, could endanger the personal safety and/or property of yourself and others. Read and follow all instructions in this manual before attempting to operate your rider mower. Failure to comply with these instructions may result in personal injury. When you see this symbol—**heed its warning.**

Your rider mower was built to be operated according to the rules for safe operation in this manual. As with any type of power equipment, carelessness or error on the part of the operator can result in serious injury. If you violate any of these rules, you may cause serious injury to yourself or others.



WARNING: The engine exhaust from this product contains chemicals known to the State of California to cause cancer, birth defects or other reproductive harm.

General Operation

- Read, understand, and follow all instructions in the manual and on the machine before starting. Keep this manual in a safe place for future and regular reference and for ordering replacement parts.
- Only allow responsible individuals familiar with the instructions to operate the machine. Know controls and how to stop the machine quickly.
- Do not put hands or feet under cutting deck or near rotating parts.
- Clear the area of objects such as rocks, toys, wire, etc., which could be picked up and thrown by the blade. A small object may have been overlooked and could be accidentally thrown by the mower in any direction and cause injury to you or a bystander. To help avoid a thrown objects injury, keep children, bystanders and helpers at least 75 feet from the mower while it is in operation. Always wear safety glasses or safety goggles during operation or while performing an adjustment or repair, to protect eyes from foreign objects. Stop the blade(s) when crossing gravel drives, walks or roads.
- Be sure the area is clear of other people before mowing. Stop machine if anyone enters the area. Never carry passengers.
- Disengage blade(s) before shifting into reverse and backing up. Always look down and behind before and while backing.
- Be aware of the mower and attachment discharge direction and do not point it at anyone. Do not operate the mower without either the entire grass catcher or the chute guard in place.
- Slow down before turning. Operate the machine smoothly. Avoid erratic operation and excessive speed.
- Never leave a running machine unattended. Always turn off blade(s), place transmission in neutral, set park brake, stop engine and remove key before dismounting.
- Turn off blade(s) when not mowing.

- Stop engine and wait until blade(s) comes to a complete stop before (a) removing grass catcher or unclogging chute, or (b) making any repairs, adjusting or removing any grass or debris.
- Mow only in daylight or good artificial light.
- Do not operate the machine while under the influence of alcohol or drugs. Watch for traffic when operating near or crossing roadways.
- Use extra care when loading or unloading the machine into a trailer or truck. This unit should not be driven up or down a ramp onto a trailer or truck under power, because the unit could tip over, causing serious personal injury. The unit must be pushed manually on a ramp to load or unload properly.
- Never make cutting height adjustment while engine is running, if operator must dismount to do so.
- Wear sturdy, rough-soled work shoes and close-fitting slacks and shirts. Do not wear loose fitting clothes or jewelry. They can be caught in moving parts. Never operate a unit in bare feet, sandals, or sneakers.
- Check overhead clearance carefully before driving under power lines, wires, bridges or low hanging tree branches, before entering or leaving buildings, or in any other situation where the operator may be struck or pulled from the unit, which could result in serious injury.
- Disengage all attachment clutches, thoroughly depress the brake pedal, and shift into neutral before attempting to start engine.
- Your mower is designed to cut normal residential grass of a height no more than 10". Do not attempt to mow through unusually tall, dry grass (e.g., pasture) or piles of dry leaves. Debris may build up on the mower deck or contact the engine exhaust presenting a potential fire hazard.

Slope Operation

- Slopes are a major factor related to loss of control and tip-over accidents which can result in severe

injury or death. All slopes require extra caution. If you cannot back up the slope or if you feel uneasy on it, do not mow it.

- For your safety, use the slope gauge included as part of this manual to measure slopes before operating this unit on a sloped or hilly area. If the slope is greater than 15° as shown on the slope gauge, do not operate this unit in that area or serious injury could result.

Do:

- Mow up and down slopes, not across.
- Remove obstacles such as rocks, limbs, etc.
- Watch for holes, ruts or bumps. Uneven terrain could overturn the machine. Tall grass can hide obstacles.
- Use slow speed. Choose a low enough gear so that you will not have to stop or shift while on the slope. Always keep machine in gear when going down slopes to take advantage of engine braking action.
- Follow the manufacturer's recommendations for wheel weights or counterweights to improve stability.
- Use extra care with grass catchers or other attachments. These can change the stability of the machine.
- Keep all movement on the slopes slow and gradual. Do not make sudden changes in speed or direction. Rapid engagement or braking could cause the front of the machine to lift and rapidly flip over backwards which could cause serious injury.
- Avoid starting or stopping on a slope. If tires lose traction, disengage the blade(s) and proceed slowly straight down the slope.

Do Not:

- Do not turn on slopes unless necessary; then, turn slowly and gradually downhill, if possible.
- Do not mow near drop-offs, ditches or embankments. The mower could suddenly turn over if a wheel is over the edge of a cliff or ditch, or if an edge caves in.
- Do not mow on wet grass. Reduced traction could cause sliding.
- Do not try to stabilize the machine by putting your foot on the ground.
- Do not use grass catcher on steep slopes.

Children

- Tragic accidents can occur if the operator is not alert to the presence of children. Children are often attracted to the machine and the mowing activity. Never assume that children will remain where you last saw them.
- Keep children out of the mowing area and in watchful care of an adult other than the operator.
- Be alert and turn machine off if children enter the area.

- Before and when backing, look behind and down for small children.
- Never carry children. They may fall off and be seriously injured or interfere with the safe machine operation.
- Never allow children under 14 years old to operate the machine. Children 14 years and over should only operate machine under close parental supervision and proper instruction.
- Use extra care when approaching blind corners, shrubs, trees or other objects that may obscure your vision of a child or other hazard.
- Remove key when machine is unattended to prevent unauthorized operation.

Service

- Use extreme care in handling gasoline and other fuels. They are extremely flammable and the vapors are explosive.
 - a. Use only an approved container.
 - b. Never remove fuel cap or add fuel with the engine running. Allow engine to cool at least two minutes before refueling.
 - c. Replace fuel cap securely and wipe off any spilled fuel before starting the engine as it may cause a fire or explosion.
 - d. Extinguish all cigarettes, cigars, pipes and other sources of ignition.
 - e. Never refuel the machine indoors because fuel vapors will accumulate in the area.
 - f. Never store the fuel container or machine inside where there is an open flame or spark, such as a gas hot water heater, space heater or furnace.
- Never run a machine inside a closed area.
- To reduce fire hazard, keep the machine free of grass, leaves or other debris build-up. Clean up oil or fuel spillage. Allow machine to cool at least 5 minutes before storing.
- Before cleaning, repairing or inspecting, make certain the blade and all moving parts have stopped. Disconnect the spark plug wire, and keep the wire away from the spark plug to prevent accidental starting.
- Check the blade and engine mounting bolts at frequent intervals for proper tightness. Also, visually inspect blade for damage (e.g., excessive wear, bent, cracked). Replace with blade which meets original equipment specifications.
- Keep all nuts, bolts and screws tight to be sure the equipment is in safe working condition.
- Never tamper with safety devices. Check their proper operation regularly. Use all guards as instructed in this manual.
- After striking a foreign object, stop the engine, remove the wire from the spark plug and thoroughly inspect the mower for any damage. Repair the damage before restarting and operating the mower.

- Grass catcher components are subject to wear, damage and deterioration, which could expose moving parts or allow objects to be thrown. For your safety protection, frequently check components and replace with manufacturer's recommended parts when necessary.
- Mower blades are sharp and can cut. Wrap the blade(s) or wear gloves and use extra caution when servicing blade(s).
- Check brake operation frequently. Adjust and service as required.
- Muffler, engine and belt guards become hot during operation and can cause a burn. Allow to cool down before touching.
- Do not change the engine governor settings or overspeed the engine. Excessive engine speeds are dangerous.
- Observe proper disposal laws and regulations. Improper disposal of fluids and materials can harm the environment and the ecology.
 - a. Prior to disposal, determine the proper method to dispose of waste from your local office of Environmental Protection Agency. Recycling centers are established to properly dispose of materials in an environmentally safe fashion.
 - b. Use proper containers when draining fluids. Do not use food or beverage containers that may mislead someone into drinking from them. Properly dispose of the containers immediately following the draining of fluids.
 - c. DO NOT pour oil or other fluids into the ground, down a drain or into a stream, pond, lake or other body of water. Observe Environmental Protection Agency regulations when disposing of oil, fuel, coolant, brake fluid, filters, batteries, tires and other harmful waste.
- Illustrated below are the location and part numbers of all labels found on your rider mower. Please follow the instruction on these labels. For replacement labels, please order by the part numbers.

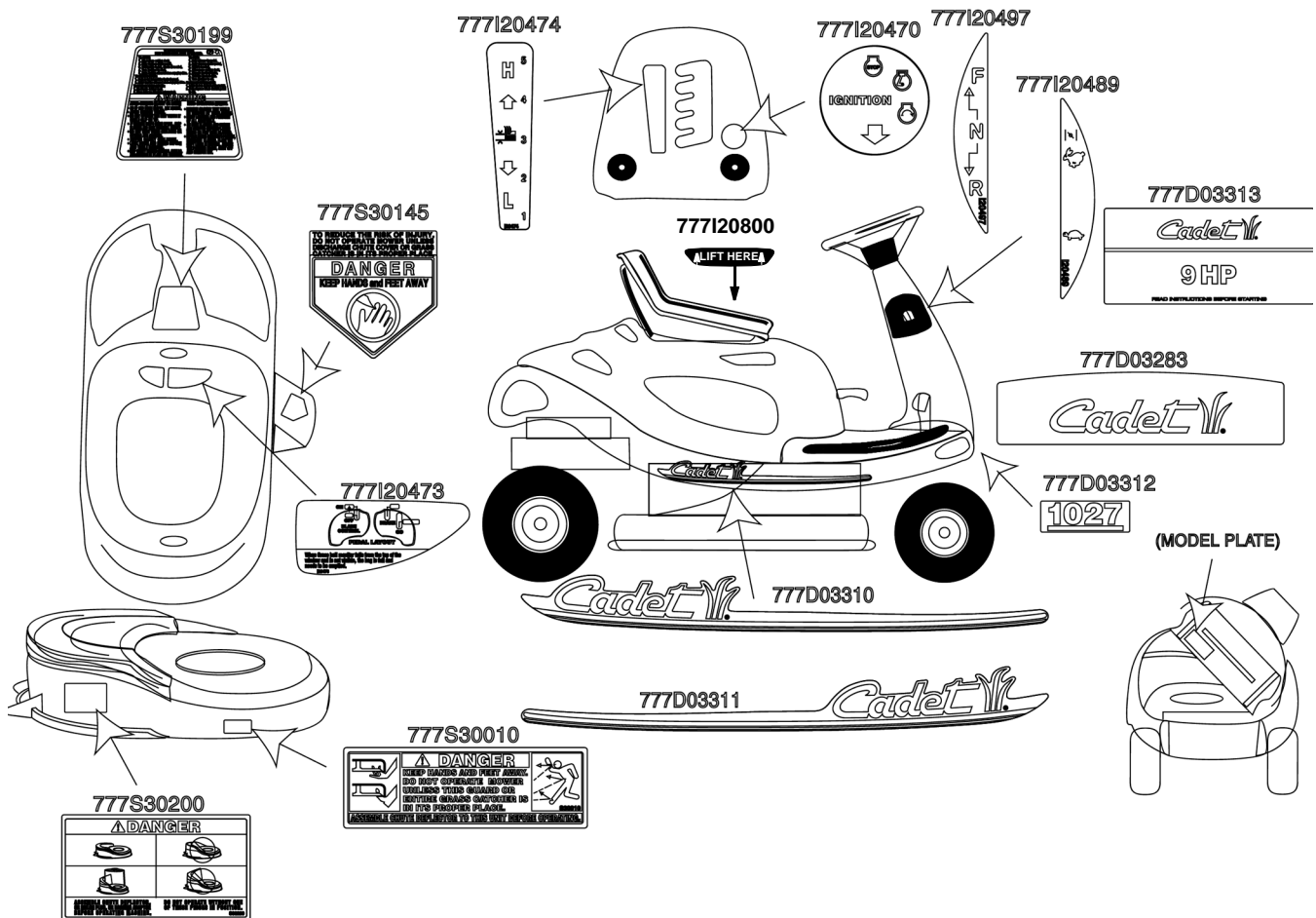

SECTION 2: SLOPE GAUGE

USE THIS PAGE AS A GUIDE TO DETERMINE SLOPES WHERE YOU MAY NOT OPERATE RIDER SAFELY:

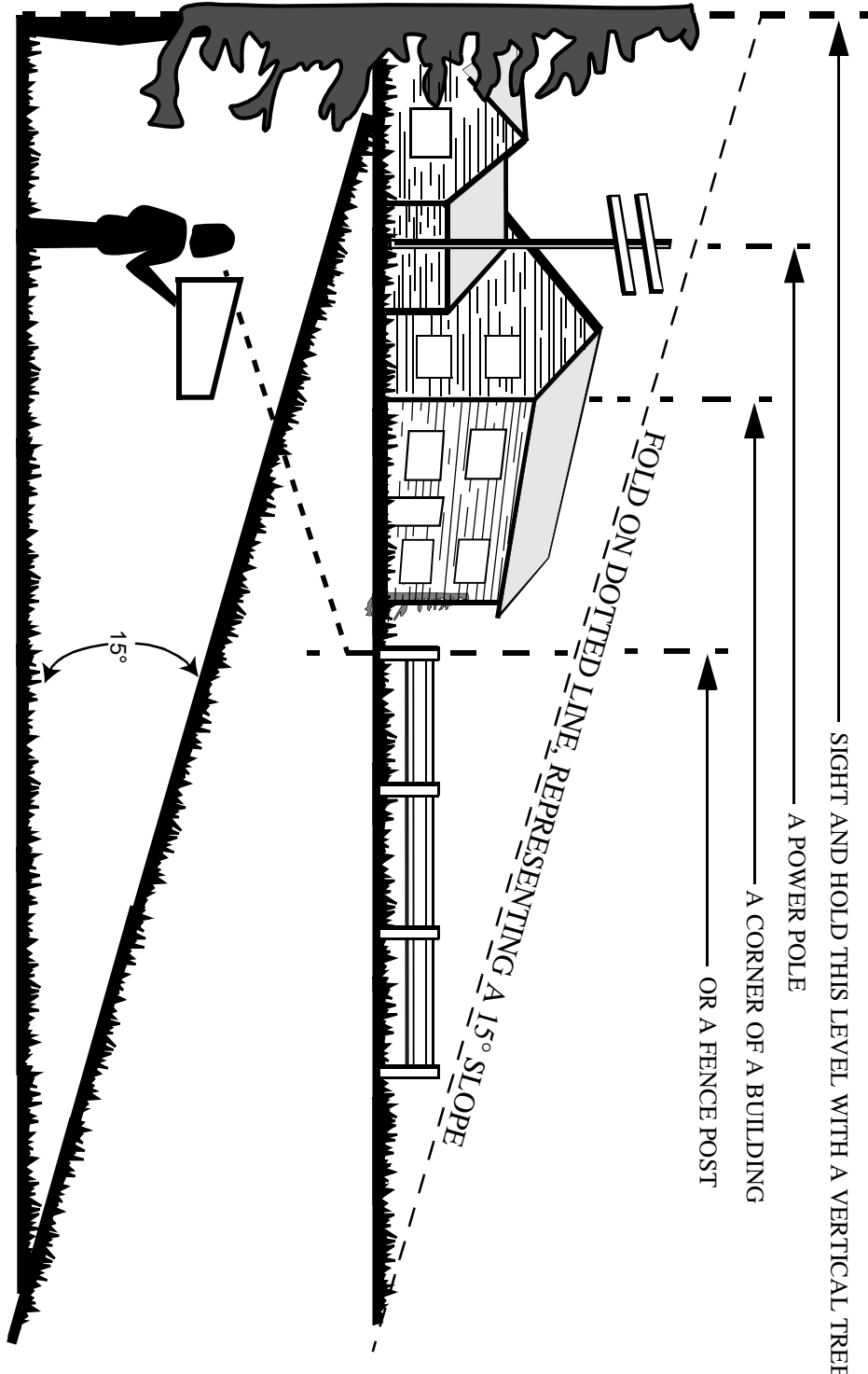

! WARNING

Do not mow on inclines with a slope in excess of 15 degrees (a rise of approximately 2-1/2 feet every 10 feet). A riding mower could overturn and cause serious injury. If operating a walk-behind mower on such a slope, it is extremely difficult to maintain your footing and you could slip, resulting in serious injury. Operate RIDING mowers up and down slopes, never across the face of slopes. Operate WALK-BEHIND mowers across the face of slopes, never up and down slopes.

SECTION 3: UNPACKING & ASSEMBLING YOUR RIDER MOWER

- Remove all screws and staples from crate.
- Holding the sides of the crate firmly, lift the top of the crate up and keep it aside. Avoid tire punctures.
- Remove and discard plastic bag covering the unit.
- Lift the rear of the mower and clear the bottom of the crate. Repeat for the front.
- Be sure parking brake is disengaged; roll unit out of the crate's way.

Loose Parts

- Remove loose parts from the grass catcher and/or the crate very carefully. Refer to Figure 1.
1. Operator's manual (not shown in Figure 1)
 2. Mulching plug & side-discharge chute
 3. Oil drain sleeve
 4. Ignition keys (not shown in Figure 1)
 5. Bumper (optional)

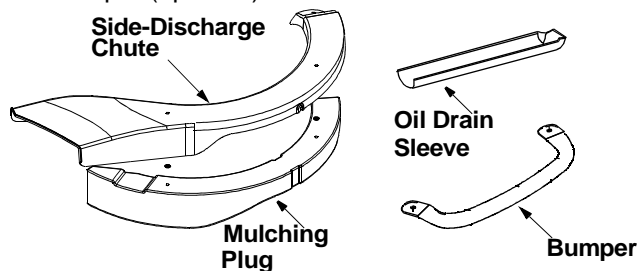

Figure 1

Attaching Battery Cables

The battery is located under the hood assembly above the left rear wheel. Refer to Figure 3 .

- To access the battery, lift the hood assembly from the left side of the hood only. Stand on the right side of the unit and pivot the hood assembly towards you until fully opened. See Figure 2 .

CAUTION: Do not lift the hood assembly by the two vent openings located behind the seat.

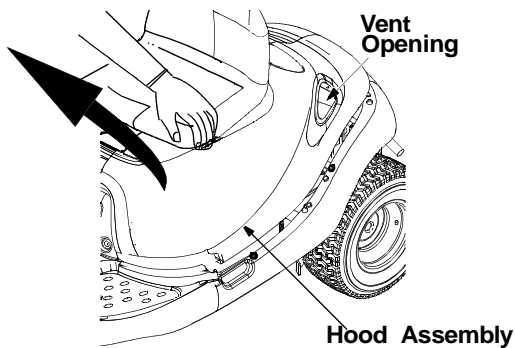

Figure 2

- Remove both wing nuts securing the battery and cover to the battery hold-down rods. See Figure 3 .

- Remove red and black insulation caps from battery terminals. See Figure 3
- Remove battery terminal screws with a Phillips screw driver or a 10 mm. socket wrench.
- Attach the red battery cable to the positive terminal (marked +), and the black battery cable to the negative terminal (marked -) on the battery. See Figure 3 .
- Align the cables with the slots in the battery cover and tighten the screws on the battery terminals.



WARNING: Press the battery cables against side of battery so that these do not make contact with flange of rider frame when it is opened or closed.

- Reassemble the battery cover to the hold-down rods on two ends with the two wing nuts removed earlier. Check to ensure that the cables pass easily through slots in cover.
- Place your right hand on the left side of the seat and slowly lower the hood assembly until it is fully closed.

CAUTION: Do not place your hand around the bottom edge of the hood assembly; it may get pinched between the hood assembly and grass catcher or the frame rail.

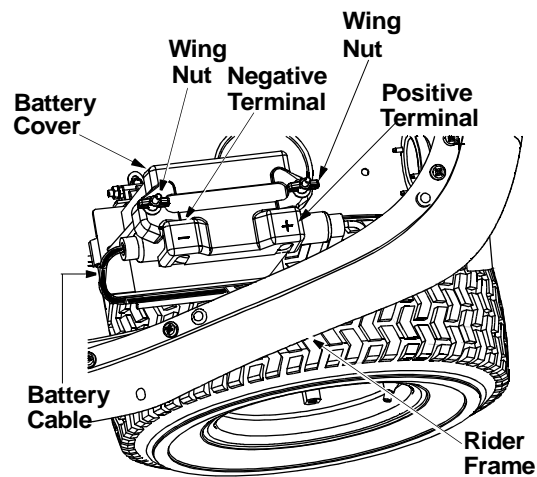

Figure 3

Attaching Side-Discharge Chute

Your riding mower is shipped to you with the grass catcher fully assembled on the unit. A side-discharge chute and a mulching plug are included as loose parts. Follow the instructions below to attach the side-discharge chute.



WARNING: Do not operate the mower if any one of the grass catcher, discharge chute or mulching plug is not firmly installed on the mower.

- Pivot the hood assembly up and lower the cutting height adjustment lever to the lowest position.
- Remove the two wing nuts (A and B in Figure 4) from two ends of the grasscatcher chute.
- Loosen the two wing nuts (C and D in Figure 4) in the middle of the chute. Do not remove. All four wing nuts hold the chute to the deck frame.
- Slide the grasscatcher chute to the right and out of the deck frame. Slide the side-discharge chute in and place it on the deck so that the four wing nut positions align with those on the deck.
- Reinsert wing nuts A and B. Tighten to secure. Tighten the two wing nuts C and D.

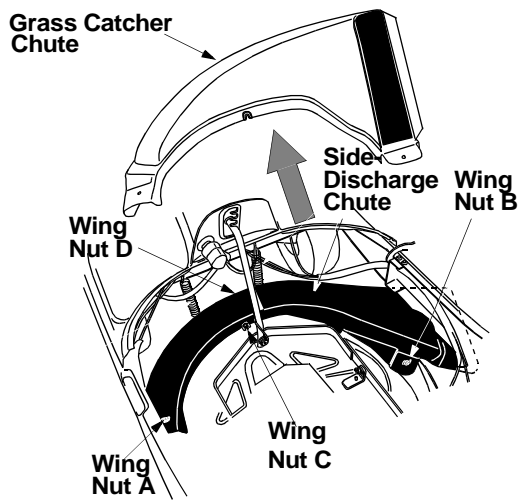

Figure 4

Attaching Mulch Plug

While operating your rider mower, you have three options: (i) to collect grass clippings in the grass catcher, (ii) to discharge grass clippings on the side, or (iii) to mulch grass and recirculate clippings back to the lawn. For the third option, attach the mulching plug to the side-discharge chute and then to the deck.

- Put two hex bolts through the mulching plug at the respective openings. See Figure 5 .

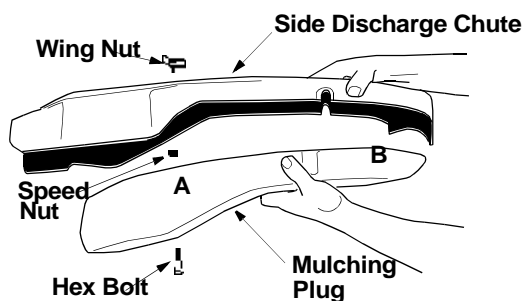

Figure 5

- Place speed nuts over the hex bolts.
- Insert the plug into the side-discharge chute aligning the two slots on two sides of the side-discharge chute with those on the mulching plug.

- To attach the mulching plug now to the unit, follow instructions on previous page to attach side-discharge chute to the deck.
- Place wing nut on each of the hex bolts and thread a few turns. See Figure 5 . Check that the mulch plug is aligned correctly within the discharge chute.
- Tighten both wing nuts

Attaching Bumper

- Remove bumper from the grass catcher.
- Loosen and remove the two hex bolts and lock nuts from the front rail on the rider mower. See Figure 6 .
- Align the two holes on the bumper tube with the corresponding holes on the rider frame (from where you removed the hardware). See Figure 6.
- Re-insert the two hex bolts through the bumper and the rider frame and secure with the two lock nuts. See Figure 6 .

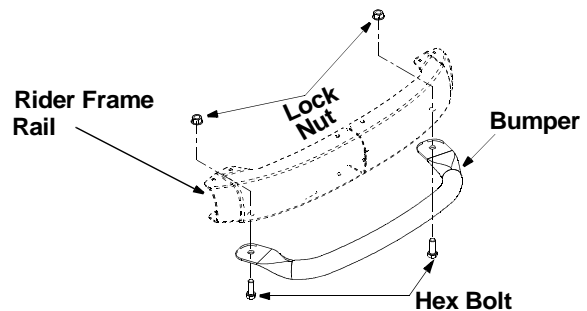

Figure 6

Attaching Hitch Plate

The hitch plate was loosely attached to the rear frame of the rider for shipping purposes.

- Loosen the nut attaching the hitch plate to the frame and swing the plate outward. Make sure that the wider side of the hitch plate aligns with the rear frame as shown in Figure 7 .
- Remove the hex bolt, lock washer and hex nut from the other end of the rear frame. Save the hardware.
- Align the hole on the hitch plate with the corresponding hole on the rear frame assembly (from where you removed the hardware).
- Re-insert the hex bolt through the hitch plate and the rear frame. Secure with the lock washer and hex nut removed earlier. See Figure 7 . Tighten both sets of hardware.

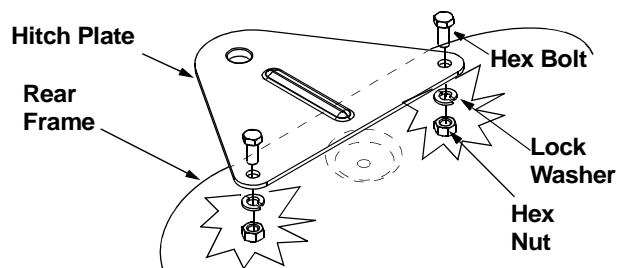

Figure 7

SECTION 4: KNOW YOUR RIDER MOWER

Compare the illustrations in Figure 8 with your rider mower to familiarize yourself with the location of various controls and adjustments. The operation of any rider mower can result in foreign objects being thrown into the operator's eyes, causing severe eye damage. **Always wear safety glasses** before operating the mower, or while performing any adjustments or repairs on it.

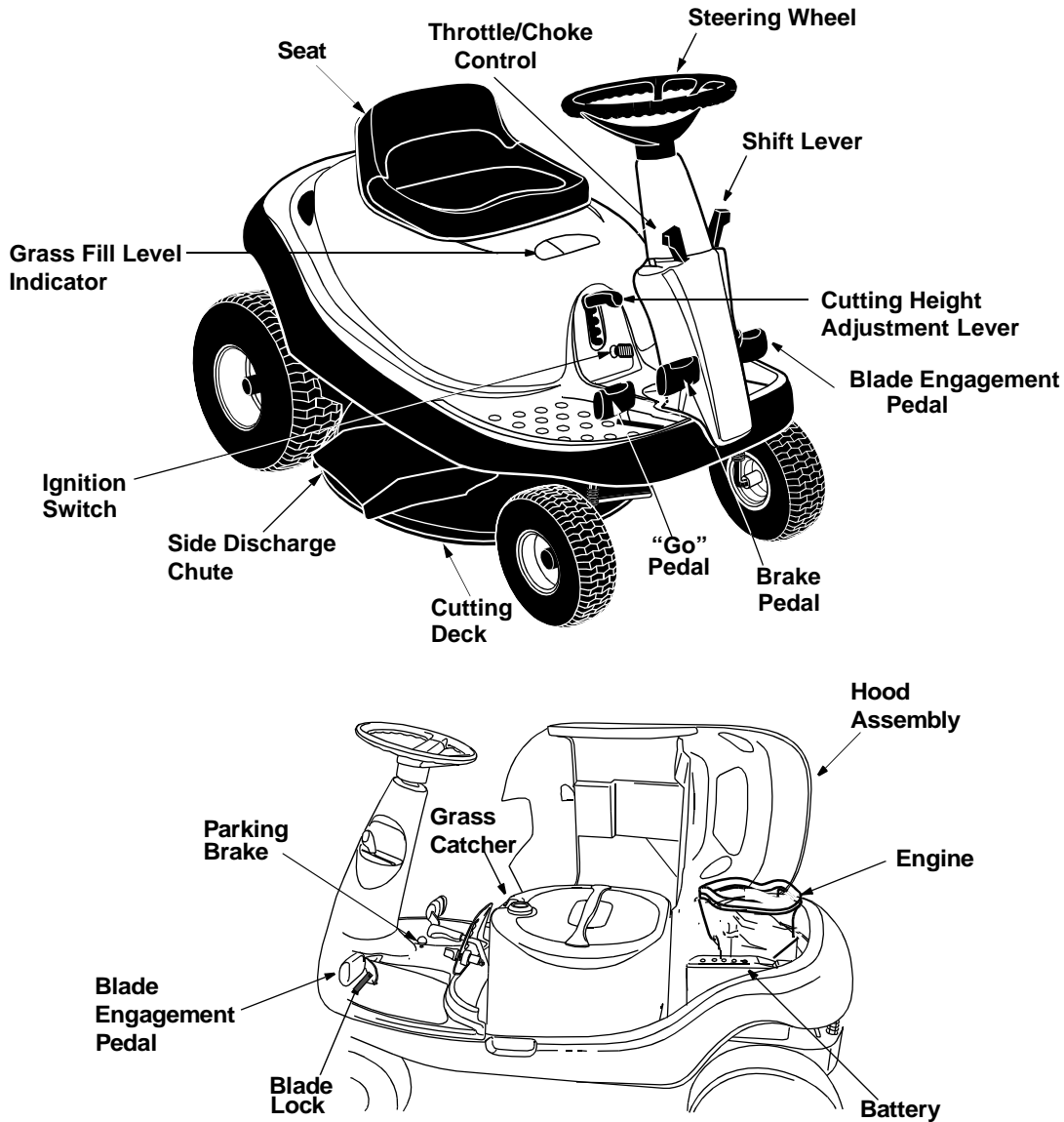

Figure 8

Throttle/Choke Control

Use to regulate the engine speed and to start the engine.

"Go" Pedal

Use to regulate the ground speed of the rider mower.

Ignition Switch

Use to turn the engine ON or OFF.

Shift Lever

Use to change direction of the mower.

Grass Fill Level Indicator

Use to determine the level of grass clipping in the bag and when to stop and empty it.

Parking Brake

Use to stop the mower from moving while parked.

Blade Engagement Pedal

Use to engage or disengage the blade.

Blade Lock

Use to lock blade at the engaged position.

Cutting Height Adjustment Lever

Use to raise and lower the cutting deck which determines the cutting height.

Brake Pedal

Use to stop the mower's forward or reverse motion.

Stopping Mower

- Release blade engagement pedal all the way.
- Release the "Go" pedal and depress the brake pedal.
- When the mower comes to a complete stop, place the shift lever in neutral.
- Engage the parking brake by pulling up on the parking brake knob.
- Turn the ignition key to OFF position and remove the key.

Safety Interlock

This unit is equipped with a safety interlock system for your protection. The interlock safety switches are connected to the brake pedal, the blade engagement pedal, the shift lever, and the seat.

The purpose of the safety interlock system is threefold:

- a. to prevent the engine from starting unless the brake pedal is depressed and the blade engagement pedal is disengaged;
- b. to shut off the engine if the blade pedal is not disengaged when the shift lever is put into **reverse**; and
- c. to shut the engine off when the operator leaves the seat without engaging the parking brake.



WARNING: To avoid the risk of serious injury, do not operate the rider mower if the interlock system is malfunctioning.

- Remove objects that could be thrown by the blade(s).
- Know location and function of all controls.
- Be sure blade(s) and engine are stopped before placing hands or feet near blade(s).
- Before leaving operator's position, disengage blade(s), place the shift lever in neutral, engage parking brake, shut engine off and remove key.

Using Shift Lever

The shift lever is used to regulate the direction of your rider mower. It can be set at forward, neutral, or reverse settings. These settings, marked as F, N, and R respectively, are located next to the shift lever on the unit. See Figure 9.

- Before you move the shift lever to any of the positions, depress the brake pedal and stop the unit. Keep your foot on the brake pedal.

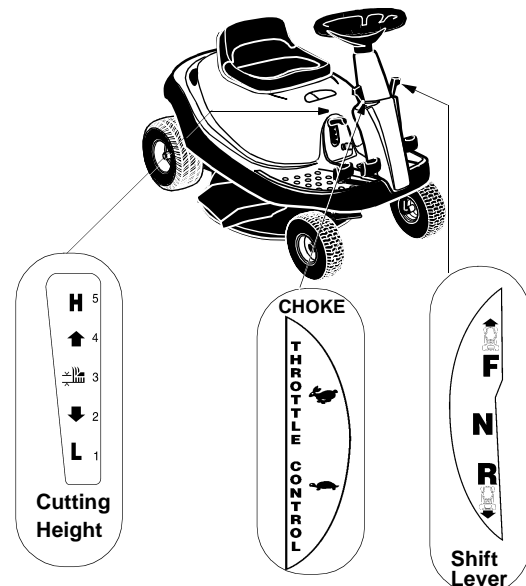

Figure 9

- Move the lever outwards (left) to remove the locking pin from the lever and slide the lever to the position desired. Look at the rear and make sure the path is free of obstacles before positioning the shift lever to the reverse.
- Do not force the shift lever. If it does not shift, release the brake pedal slightly to line up the shifting collar in the transmission, then try to move the shift lever.
- Slowly release the brake pedal and take your foot off the pedal. Always make sure that there is no one in the way when you run the mower.

Grass Fill Level Indicator

This indicator was designed to add convenience to your riding mower. While the mower is running, air will flow through the discharge chute and into the grass catcher. If the grass catcher is **empty**, air flows through easily pushing the ball up. If the grass catcher is **full**, air does not flow through it allowing the ball to fall. So if you see the ball in the grass catcher fill level indicator falling down, you should stop the mower and empty the bag.

SECTION 5: OPERATING YOUR RIDER MOWER

Using Throttle/Choke Control

The throttle/choke control is used to increase or decrease the speed of the engine. The FAST and the SLOW positions are marked with illustrations of a rabbit and a turtle respectively. See Figure 9.

- For normal operation and when using a grass catcher, move the throttle/choke control to the FAST position.
- For maximum charging of the battery and also for a cooler engine while running, move the throttle/choke control to the FAST position.
- For transport and to tow pull-behind attachments, move the throttle/choke control to the SLOW position.
- Do not adjust the governor to increase or decrease the engine speed. The governor is set at the factory for maximum engine performance, and should not be altered.

Using Parking Brake

To engage parking brake

- Completely push the brake pedal down and stop the unit.
- With your right foot on the brake pedal, move the shift lever to the neutral position.
- Continuing to hold down the brake pedal with your right foot, pull up the parking brake knob. Make sure the parking brake holds the unit.
- Release the brake pedal. Stop the engine and remove the ignition key. Now your rider mower is parked.

To release the parking brake

- Depress the brake pedal. The parking brake will be automatically disengaged.

Before Starting

Service the engine with gasoline as described in the engine manual. Check oil level.



WARNING: Never fill fuel tank indoors, or when engine is running or hot. Do not smoke while filling up the gasoline tank.

Starting Engine

- Attach the wire to the spark plug.
- Depress the brake pedal with your right foot.
- Set throttle/choke control in the CHOKE position (all the way forward).
- Place the shift lever in the NEUTRAL position.

- Turn the ignition key to the START position. As soon as the engine starts, let the key return to the ON position.
- Move throttle/choke control out of CHOKE position and into FAST throttle position.

Starting Mower

- Depress the brake pedal so that the parking brake is disengaged.
- Place the shift lever in either the FORWARD or the REVERSE position as you desire. **Look to the rear and check before backing up.**
- Release the brake pedal.
- Depress the "Go" pedal.
- To stop, release the "Go" pedal and depress the brake pedal.
- Press the blade engagement pedal downward until the blades are turning. The blades can be engaged either while the mower is in motion or while it is standing.

NOTE: Your rider mower is equipped with a blade lock to keep the blade engaged without the operator having to depress the blade pedal continuously. See Figure 8.

- **To engage the blade lock:** While pressing down on the blade pedal, push the blade lock down with your heel. It should click into the "blade engaged" position. To disengage the blade lock, simply push down on the blade pedal and release the lock.



WARNING: When the blades are engaged, keep feet and hands away from the discharge opening, the blades or any part of the deck.

Stopping Mower

- Release blade engagement pedal all the way.
- Release the "Go" pedal and depress the brake pedal.
- When the mower comes to a complete stop, place the shift lever in neutral.
- Engage the parking brake by pulling up on the parking brake knob.
- Turn ignition key to OFF position and remove it.

NOTE: Do **not** leave the key in the ON position when you are not operating the mower. Such action will drain the battery dead.

To Empty Grass Catcher

- Stop the mower completely, pull up on the parking brake knob and take the ignition key out. Get off the operator's seat.

- Pivot the cover up. Pull up the grasscatcher bag by the handle and take it to the proper disposal site. See Figure 10 .
- Hold the bag away from your body. Push down on the bag lever and let the bottom section of the bag fall downwards. The grass clippings will be disposed of from the bottom. See Figure 10 .
- Tap the bag on the ground so that the three legs of the bag press against the ground. The bag lever should snap close while you push the bag downwards.
- Replace the bag on to the mower making sure the bag is placed on the flange on top of the discharge chute. Pivot the cover down.

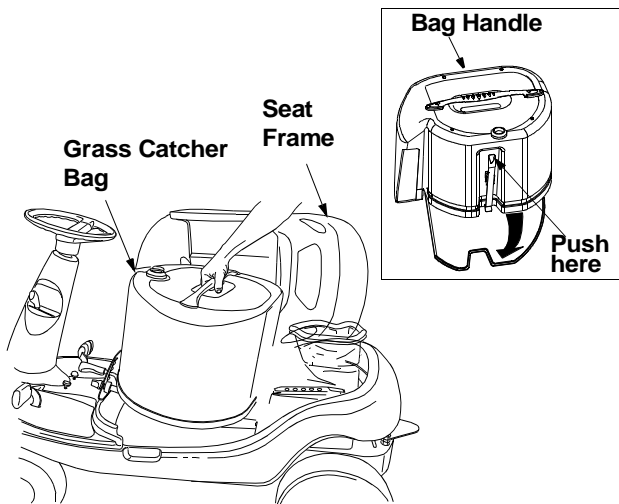

Figure 10

Using The Mower

Observe safety rules listed on pages 3-5 of this manual for safe operation of your mower.

- Before mowing, make sure that the cutting deck is leveled. For deck adjustment, refer to page 14.
- You can engage the blade by pressing on the blade engagement pedal with your left foot while sitting on the operator's seat.

- When mowing an area for the first time, watch out for objects lying on the grass. If you strike a foreign object, stop the engine. Remove wire from spark plug and thoroughly inspect the mower for any damage. Repair the damage before operating it again.
- Avoid scalping the lawn by adjusting the cutting height upwards and/or sharpening the blades.
- Mow at full throttle. Learn the terrain on which you are mowing. For best mowing results, mow only when the grass is dry.
- The recommended mowing pattern is given below:

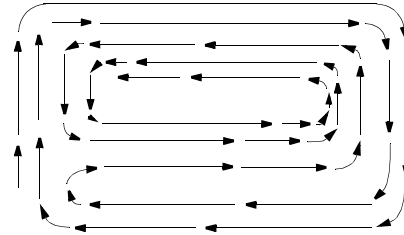

- Mow grass often and in regular intervals so that you can cut only 1/3 of the grass blade in one mowing.
- To empty grass bag, **stop the mower completely**, engage the parking brake, and turn the ignition off. This will prevent the hot engine exhaust gas from browning the grass.
- Many communities no longer haul grass clippings to landfills. Composting the clippings from your grass catcher is a viable solution. For this you will have to empty the grass catcher at the designated composting site.
- Your rider mower is equipped with a mulching plug to mulch the grass and recycle into the lawn instead of collecting in the grasscatcher bag.
- Mulch only when the grass is dry. Mulching wet grass may damage the underside of the deck because wet grass tends to stick to it. Clean deck thoroughly if you mulch wet grass.
- For effective mulching, overlap mowing paths so that the clippings are distributed evenly.

SECTION 6: MAKING ADJUSTMENTS



WARNING: Do not at any time make any adjustment to riding mower without first stopping engine and disconnecting spark plug wire.

Brake Pedal

During normal operation of the rider mower, the brake is subject to wear and tear. Check the brake periodically by carrying out the following test:

- Release the parking brake and place the rider mower in neutral. Depress the brake pedal and try to roll the rider mower. The tractor should not move. If the tractor moves, adjust the brake.



WARNING: Do not adjust the brake while the engine is running. Be sure to block the wheels of the rider mower before making any adjustments on the brake cable.

Adjustment to the brake pedal is made at the cable end. See Figure 11 .

- Set the parking brake and turn ignition key off.
- Shift the cutting height lever to the lowest position.
- Pivot the cover up and remove the grasscatcher bag and the side-discharge chute or the mulching plug from the mower.
- Disconnect wire from the spark plug.
- Locate the brake cable on the right side under the front housing. See Figure 11 .
- Using a pair of 1/2" wrenches, loosen the jam nuts and back the cable out to tighten or thread inward to loosen. See Figure 11 inset.
- Retighten the jam nuts when proper tension is reached.
- Unlock the parking brake and repeat the test described above. Readjust if necessary.

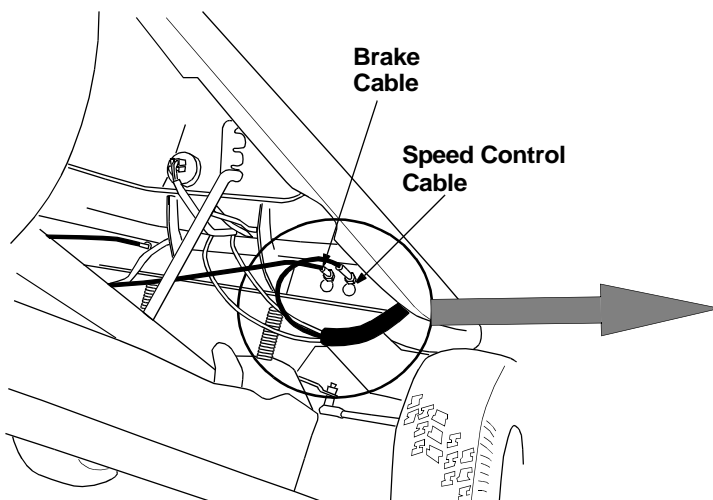

"Go" Pedal

Adjustment to the "Go" pedal is made at the cable end. See Figure 11 .

- Set the parking brake and turn ignition key off.
- Shift the cutting height lever to the lowest position.
- Pivot the hood assembly up and remove the grasscatcher bag and the side-discharge chute or the mulching plug from the mower.
- Disconnect wire from the spark plug.
- Locate the speed control cable under the front housing. See Figure 11 .
- Loosen the jam nuts and back the cable out to tighten or thread inward to loosen as shown.
- Retighten the jam nuts when proper tension is reached.
- Reconnect the spark plug wire and pivot the hood assembly down.

Cutting Height

The deck cutting height adjustment lever is located on the hood assembly. For a representation of the cutting height positions, refer to Figure 9.

- Pull the lever out of the slot and slide it upward or downward to the desired cutting height.
- Lower the cutting height to mow close to the ground.
- Raise the deck height to the highest position when you ride on a sidewalk or a road.
- To mow tall or thick grass, move the cutting height adjustment lever to the highest position and cut. Then move the lever to a lower position and cut again.

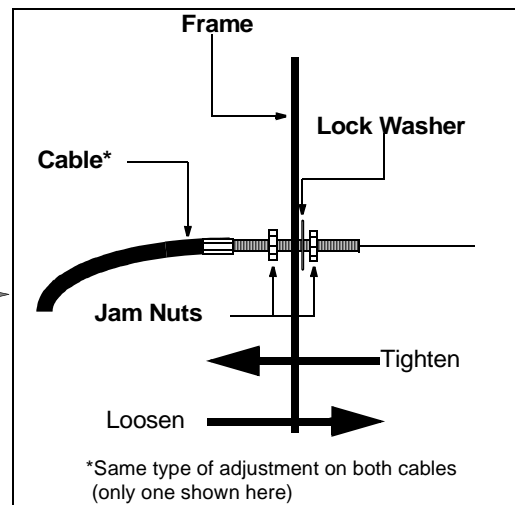

Figure 11

Seat Position

The seat position on the rider mower can be adjusted to maximize the operator's convenience.

- Stop the mower completely and engage the parking brake. Turn ignition off.
- Pivot the hood assembly up.
- Loosen the four self-tapping screws on the bottom of the seat.
- Slide the seat forward or backward in the slot, and position it as desired. Retighten the four screws.

Blade Brake/PTO

The blade engagement pedal should be adjusted so that if you depress it about 3/4" from the front of the slot, it should start engaging the deck belt. The PTO (power take off) switch is located in the blade brake slot on the left side of the upper frame. See Figure 12. The blade engagement pedal needs to make contact with the PTO switch for the engine to start.

Under normal operation, the blade engagement pedal should not require frequent adjustment. However, perform the following test periodically and make sure that it is in fine working condition.

- Pivot the hood assembly up and check if there is enough slack on the deck engagement cable.
- Depress the blade engagement pedal (about 3/4 inch) and check if the belt is engaging.
- If the cable is tight or too loose or the belt is not engaging, adjust the deck engagement cable.

NOTE: The deck engagement cable will be correctly adjusted when the cable moves approximately 1/2" off center line in both directions.

Adjustment to the blade brake will have to be made at the cable end. See Figure 12.

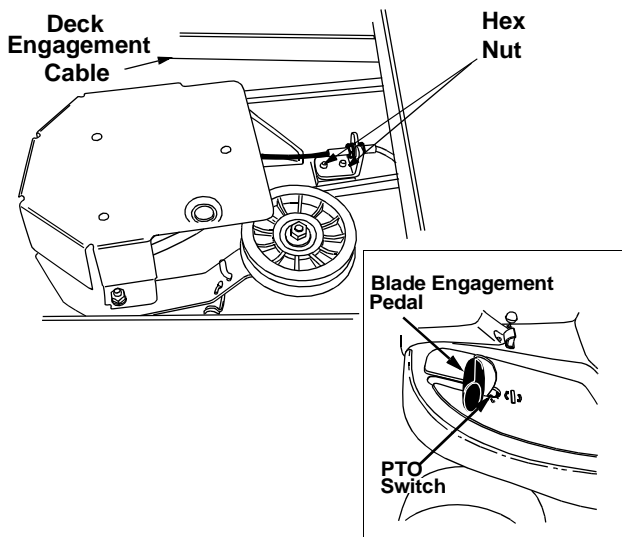

Figure 12

- If the belt is slipping when you depress the blade engagement pedal about 3/4", loosen the two hex nuts on the cable. See Figure 12.
- If the belt is engaging sooner than when the blade engagement pedal is 3/4" from the PTO switch, tighten both hex nuts on the cable. See Figure 12.
- Repeat the blade engagement test and readjust if necessary.
- Pivot the hood assembly back.

Wheel Alignment

The front wheels should toe-in 1/16-5/16 inch. To adjust toe-in, follow these steps:

- Remove the 3/8" hex nut which holds the ball joint to the steering segment. See Figure 13.
- Adjust the ball joint in or out until the wheels toe-in approximately 1/16-5/16" (Dimension "B" should be approximately 1/16-5/16" less than dimension "A"). See Figure 13.
- Replace the ball joint into the steering segment, and replace the 3/8" hex nut.

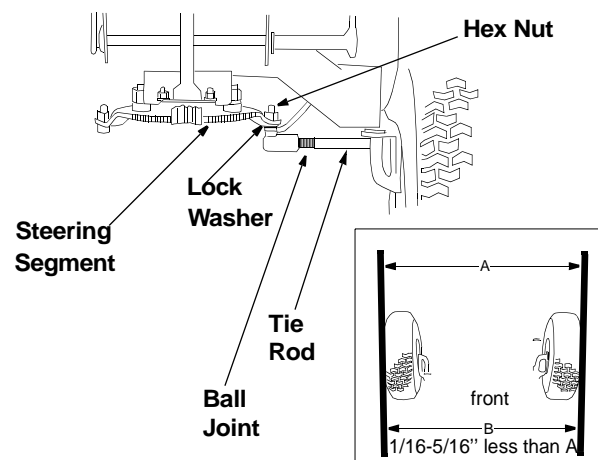

Figure 13

Adjusting the Deck

IMPORTANT: Perform adjustments to the deck on a flat, level surface. Before continuing with deck adjustment, check air pressure in all four tires. Recommended air pressure is 12 psi. Please note that the valve stems on this rider mower are on the inside of the front wheels and on the outer side of the rear wheels.

- Lift the hood assembly and remove grass catcher from the rider mower. Place the deck in the highest position.
- Inspect rear of deck. The front of the deck should be approximately 1/4" to 3/8" lower than the rear of the deck. To maintain that, you may have to adjust the deck pitch. If the deck is contacting the cable bracket on the front of the transmission, you will have to adjust the rear deck height. Follow the steps on the next page for adjustments.

- Completely loosen, but do not remove, the top hex nut out of the three hex nuts that hold the hex bolt and the ferrule on the deck hanger link assembly.
- **Do not try to loosen or tighten the bottom nut.**
- Thread the middle nut as far down as possible.
- When desired adjustment is reached, retighten the two nuts. Adjust both sides if necessary.

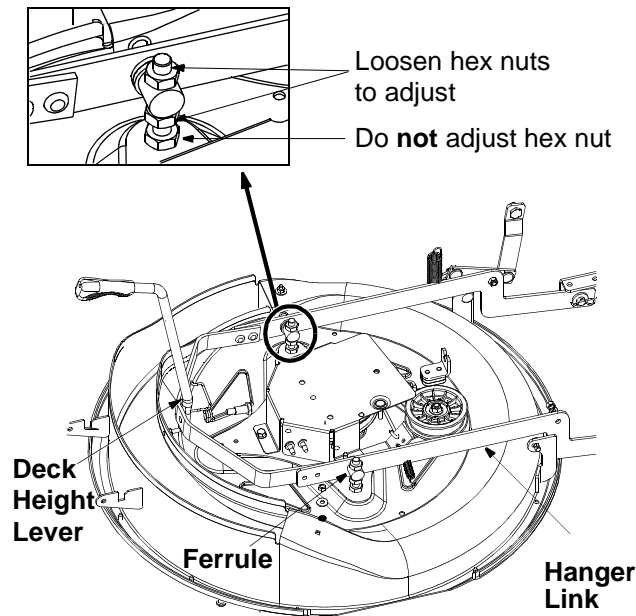

Figure 14

SECTION 7: SERVICING YOUR RIDER MOWER

Belt Replacement

There are two drive belts and one deck belt in your rider mower; follow the description below to identify the belts.

1. The lower drive belt goes from the variable speed pulley to the transmission pulley.
 2. The upper drive belt goes from the variable speed pulley to the upper sheave of engine pulley.
 3. The deck belt goes from the deck pulley to the lower sheave in engine pulley.
- Periodically check to see if these belts are too loose or damaged through wear and tear. If so, replace with new belt.

Deck Belt

- Engage the parking brake and turn the ignition off. Pivot the hood assembly up and remove the grass catcher. Remove the spark plug wire.
- Put the deck at the lowest cutting height by adjusting the cutting height adjustment lever to the lowest position.
- Using a 1/2" socket wrench, remove two self-tapping screws, lock washer and hex nut that hold the deck belt cover to the deck. See Figure 15. For

this, you will have to work from the top left side of the mower. Remove the belt cover.

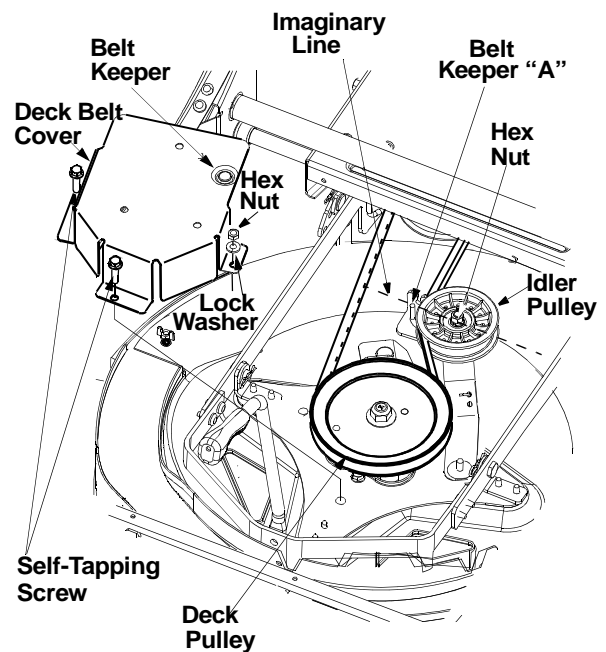

Figure 15

- Using a 9/16" wrench, loosen the hex nut on the idler pulley. See Figure 15.
- Remove belt from around deck pulley, idler pulley, and the engine pulley.
- Place the new belt around the deck pulley and the engine pulley making sure that the belt is routed inside the belt keepers. There are two belt keepers under the grass catcher, one on the idler and the other under the deck belt cover. See Figure 15.
- Reinstall deck belt cover and secure with two self-tapping screws, lock washer and hex nut.

NOTE: Belt keeper "A" must be mounted on the outside of the belt.

- Make sure to align the belt keeper in line with the frame. See Figure 15.

NOTE: An imaginary line between the belt keeper and idler pulley should be parallel to frame. See Figure 15.

- Replace the grass catcher and pivot the hood assembly back.

Lower Variable Speed Belt

- Remove the rear deck belt guard following first five steps for deck belt removal. Remove belt from the engine pulley.
- Push the spring loaded idler, located on the left side of the transmission, to the right. Remove belt from around the idler and then the transmission pulley. See Figure 16 .

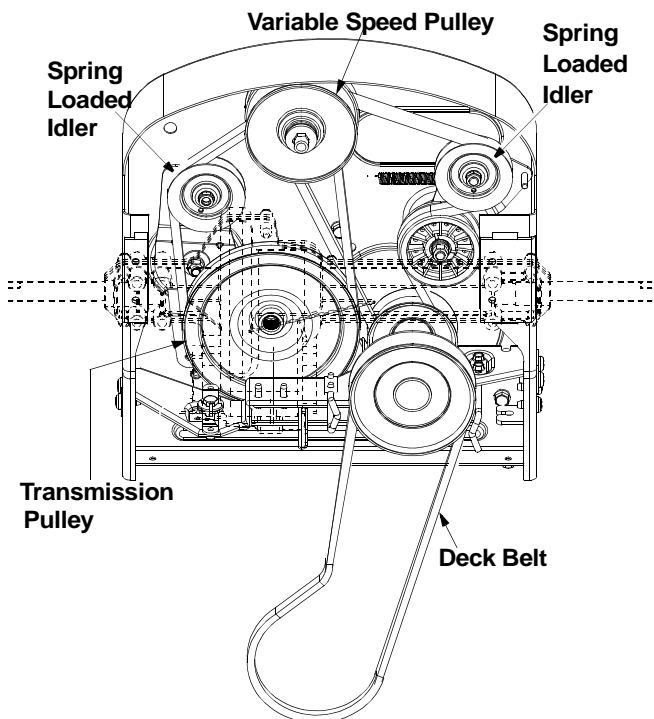

Figure 16

- Using a 9/16" socket, remove bolt, spacer and the flat washer from the variable speed pulley. See Figure 16 .
- Drop the pulley down and remove the belt.
- Replace new belt and reassemble following above instructions in reverse order.
- Make sure that the belt is **routed inside of belt keeper**, and the belt keeper is reassembled in the same location from where it was removed.

Upper Variable Speed Belt

- Remove the engine pulley using a 9/16" socket wrench with a 6" extension. The engine pulley is located in front of the transmission.
- Drop the engine pulley down and remove the belt from around it.
- Push the idler bracket to the right and remove the belt. See Figure 16 .
- Replace belt and reassemble in reverse order.

Fuse Replacement

The fuse is located next to the spark plug under the rear frame. Fuses seldom fail without a reason. If the fuse blows, the source problem must be corrected or the new fuse will blow again.

- Check for loose connections in the fuse holder and replace holder if necessary. A dead short may be in the cranking or charging circuit where insulation may have rubbed through and exposed bare wire.
- Replace the wire or repair with electrician's tape if the wire strands have not been damaged. Also look for a wire pinched between body panels, burned by the exhaust pipe or muffler, or rubbed against a moving part.
- Stop the rider mower and engage the parking brake. Remove ignition key.
- Pivot the hood assembly up. Disconnect the spark plug wire and ground it.
- Pull the fuse out of the lead wire.
- Replace with new automotive fuse.
- Make sure to reconnect the spark plug wire before pivoting the hood assembly back.

SECTION 8: MAINTAINING YOUR RIDER MOWER

General Recommendations

- Always observe safety rules when performing any maintenance.
- The warranty on this rider mower does not cover items that have been subjected to operator abuse or negligence. To receive full value from the warranty, operator must maintain the rider mower as instructed in this manual.
- We do not recommend the use of pressure washers or garden hose to clean your unit. These may cause damage to electrical components, spindles, pulleys, bearings or the engine. The use of water may shorten life of your rider mower and reduce its serviceability.



WARNING: Always stop engine and disconnect spark plug wire before any maintenance or adjustments.

Cutting Blade

Removal



WARNING: Protect your hands by wearing heavy gloves or using a rag to grasp the cutting blade.

- Remove the 5/8" hex flange nut which holds the blade to the blade spindle.
- Remove blade from the spindle. See Figure 17.

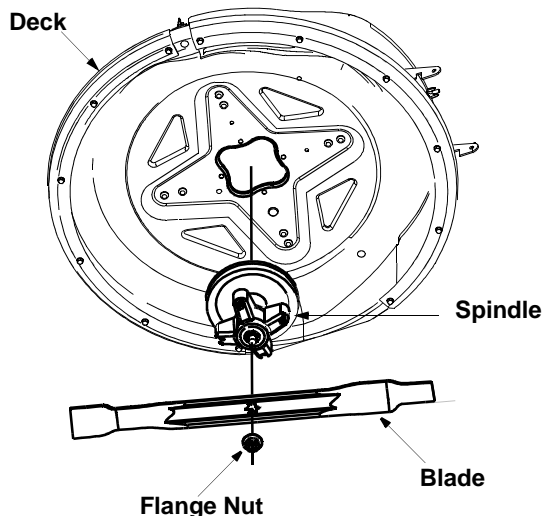

Figure 17

Sharpening

- When sharpening the blade, follow the original angle of grind as a guide. It is **extremely important** that each cutting edge receives an equal amount of grinding to prevent an unbalanced blade. An unbalanced blade will cause excessive vibration

when rotating at high speeds, may cause damage to the mower and/or cause personal injury.

- The blade can be tested for balance by balancing it on a round shaft screwdriver. Remove metal from the heavy side until it balances evenly.

Reassembly

- Before reassembling the blade to the unit, lubricate the spindle with light oil (or engine oil).
- Be sure to properly align "star" fitting on blade with "star" on spindle.
- When replacing the blade, be sure to install the blade with the side of the blade marked "Bottom" (or with part number) facing the ground when the mower is in the operating position.
- Blade Mounting Torque: 70/90 foot-pounds maximum.

NOTE: To ensure safe operation, all nuts and bolts must be checked periodically for correct tightness.

Oil Drain Sleeve

Your rider mower has a plastic oil drain sleeve, packed with the loose parts, for draining oil from the crankcase.

- To drain the oil, snap small end of the oil drain sleeve onto oil sump. See Figure 18.
- Remove drain plug and drain oil into a suitable container.

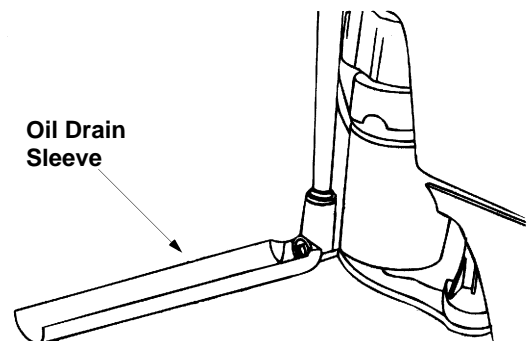

Figure 18

Engine

Refer to the separate engine manual for engine maintenance instructions.

- Maintain engine oil as instructed in the separate engine manual packed with your unit. Read and follow instructions carefully.
- Poor engine performance and flooding usually indicates that the air cleaner should be serviced. Service air cleaner as per the engine manual. Clean frequently under extremely dusty conditions.

- The spark plug should be cleaned and the gap reset once a season. Spark plug replacement is recommended at the start of each mowing season. Check engine manual for correct plug type and gap specifications.

NOTE: *Your engine is equipped with a resistor spark plug, When replacing plug, make sure to use resistor type.*

Lubrication

See Figure 19 for an illustration of the lube points described below.

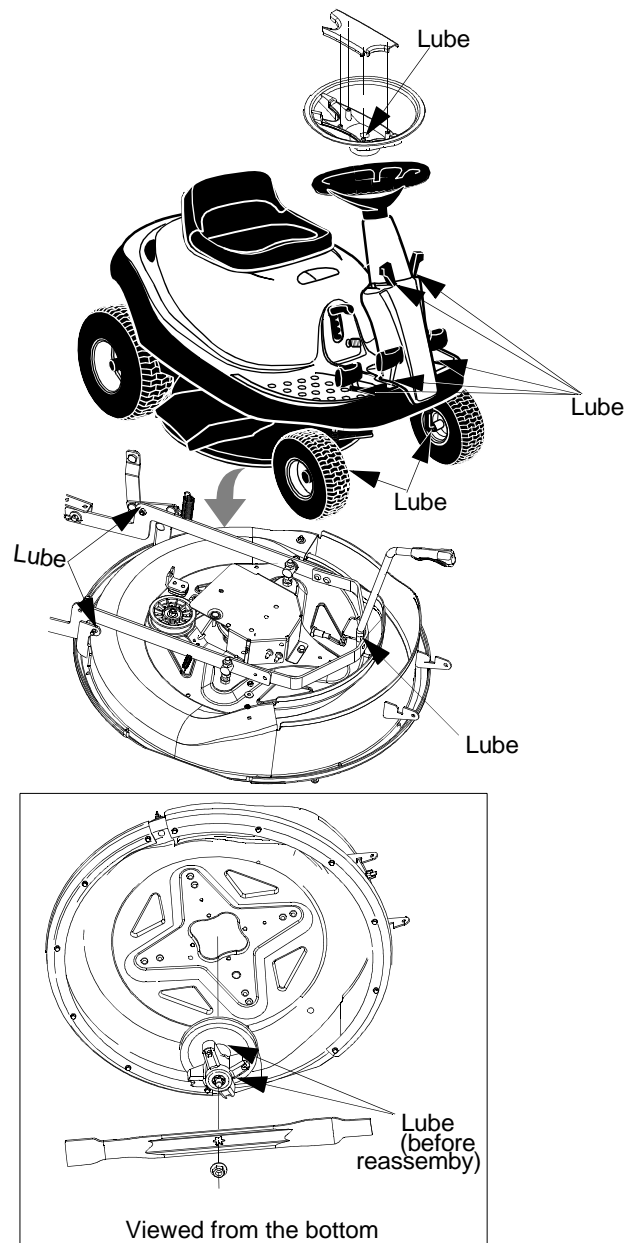

Figure 19: Lubrication Chart

Blade Assembly

- Lubricate blade assembly and deck spindle only while reassembling the blade either after sharpening or replacement.

Pivot Points

- Lubricate all pivot points with light oil at least once a season.

Steering Shaft and Gear

- Lubricate steering shaft and spline at least once a season with light oil.
- Lubricate teeth of the external steering gears with automotive multi-purpose grease every 25 hours of operation or once a season.

Linkage

- Lubricate all deck linkage and height adjustment linkage with a light oil.

Front Wheels

- Lubricate at least once a season with automotive multi-purpose grease.

Engine

- Maintain the engine as recommended in the separate engine manual.

Cleaning Engine

- Promptly wipe off any fuel or oil spilled on the machine with clean cloth.
- Clean the underside of the blade housing after each mowing. Do not let clippings or debris accumulate around the blade which may cause rust on the deck.
- Using a brush or cloth, remove grass, chaff or debris from the finger guard on the engine daily to prevent overheating of the engine. Do not clean with a forceful spray of water since water contaminates the fuel system.
- Keep the governor linkage, springs and controls free of debris.
- If engine muffler is equipped with spark arrester screen, remove and clean the screen regularly. Replace if damaged or plugged with debris. Clean muffler area and remove any grass or other debris before operating the unit.

Fuel Filter

Your unit is equipped with a replaceable in-line fuel filter. Replace filter whenever contamination or discoloration is noticed. Order replacement filter through your engine authorized service dealer.

SECTION 9: OFF-SEASON STORAGE

If the machine is to be inoperative for a period longer than 30 days, prepare for storage as follows.

Rider Mower

- Clean the engine and the entire unit thoroughly.
- Lubricate all pivot points. Wipe the entire machine with an oiled rag to protect the surfaces.
- Store unit in a clean, dry area. Do not store next to corrosive materials, such as fertilizer.
- When storing any type of power equipment in an unventilated or metal storage shed, care should be taken to rustproof the equipment. Using a light oil or silicone, coat the equipment, especially any chains, springs, bearings and cables.

Battery

- Charge battery fully. The battery loses some of its charge each day when the unit is not used.

NEVER store battery without a full charge. Recharge battery before returning to service or every two months, whichever occurs first.

- When storing unit for extended periods, disconnect battery cables and remove the battery from the unit.
- Clean dirt and chaff from cylinder, cylinder head fins, blower housing, rotating screen and muffler area.

Engine

- Refer to the engine manual for storage instructions. Make sure to store the engine properly so that your equipment can work smoothly afterwards.

SECTION 10: TROUBLE-SHOOTING

Trouble	Possible Cause	Remedial Action
Excessive vibration	<ol style="list-style-type: none"> 1. Bent or damaged blade 2. Bent blade. 	<ol style="list-style-type: none"> 1. Stop engine immediately. Check all pulleys, blade adapters, keys and bolts for tightness and spindle damage. Tighten or replace any damaged parts. 2. Stop engine immediately. Replace damaged blade. Only use original equipment blades.
Mower will not discharge grass or leaves uncut strips	<ol style="list-style-type: none"> 1. Engine speed low. 2. Speed selection. 3. Cutting height set too low. 4. Blades short or dull. 	<ol style="list-style-type: none"> 1. Throttle must be set at full throttle. 2. Use lower ground speed. Slower the ground speed, better the quality of cut. 3. Raise the deck. 4. Sharpen or replace blades (uncut strip problem only).
Broken Belt	<ol style="list-style-type: none"> 1. Sudden stop or shock load to belt 2. Incorrect belt used 3. Belt engaged abruptly 4. Defective or damaged belt 	<ol style="list-style-type: none"> 1. Inspect rider for cause such as foreign objects stuck in between deck and frame or belt path. Remove obstruction and check for damage. Replace belt if needed. 2. Replace with proper belt. Check Parts list in this manual for correct part number. 3. Engage belt slowly by depressing the blade engagement pedal slowly. 4. Replace with proper belt. Follow instructions in Service and Adjustments section.
Belt comes off	<ol style="list-style-type: none"> 1. Belt too loose; stretched 2. Broken or weak idler spring 	<ol style="list-style-type: none"> 1. Readjust belt. Replace if needed. Follow instructions for belt replacement in the Service and Adjustments section. 2. Replace. Order with correct part number from Parts List in this manual.
Belt shreds	<ol style="list-style-type: none"> 1. Belt guides or guards incorrectly adjusted 2. Pulleys not aligned 3. Pulley rusted or in otherwise bad condition; frozen bearing 	<ol style="list-style-type: none"> 1. Adjust belt guides and guards so that these are approximately 1/16 to 1/8 inch from belt when engaged. 2. Realign pulleys to be within approximately 1/16 inch of each other. Check with straight edge. Make sure fastening hardware is tight. 3. Replace pulleys. Order with correct part number from the Parts List in this manual. Adjust new pulleys to 1/16 inch.
Engine will not crank	<ol style="list-style-type: none"> 1. Safety switch button not depressed 2. Battery installed incorrectly 3. Battery dead or weak. 4. Blown fuse or circuit breaker 5. Engine ground wire loose. 	<ol style="list-style-type: none"> 1. There are two switches in the starting circuit of your unit. Make sure that the actuator is fully depressing both switch buttons. Brake pedal must be depressed and blade engagement pedal disengaged. 2. Install the battery with negative terminal attached to the black ground wire. Attach the positive terminal to the red wire which goes to the solenoid. Charge the battery fully before installation. 3. Replace battery. 4. Replace fuse following instructions on page 16. 5. Make sure the black ground wire runs from engine to frame or mounting bolt.

Trouble	Possible Cause	Remedial Action
Engine cranks but will not start	<ol style="list-style-type: none"> 1. Throttle/choke not in starting position. 2. No fuel to the carburetor 3. Fuel line or in-line fuel filter plugged 4. No spark to spark plug 5. Faulty spark plug 6. Dirty air cleaner 	<ol style="list-style-type: none"> 1. Check owner's guide for correct position for throttle control/choke for starting. 2. Gasoline tank empty. Fill with gasoline. 3. Remove and clean fuel line. Replace filter if necessary. 4. Spark plug lead disconnected. Connect lead. Hold spark plug lead away from engine block about 1/8". Crank engine. There should be a spark. If not, have engine repaired at authorized engine service dealer. 5. To test, remove spark plug. Attach spark plug lead to spark plug. Ground the spark plug body against the engine block. Crank the engine. The spark plug should fire at the electrode. Replace if it does not. 6. If the air cleaner is dirty, the engine may not start. Clean or replace as recommended by the engine manufacturer.
Engine smokes	<ol style="list-style-type: none"> 1. Engine oil has been overfilled 2. Dipstick not seated or broken 3. Engine loses crankcase vacuum 	<ol style="list-style-type: none"> 1. Check oil level. 2. Replace defective part. 3. Engine breather defective. Replace.



For repairs beyond those listed in the Trouble-Shooting chart above, please contact an authorized service dealer or call Cub Cadet Customer Service at **1- (800)-528-1009**.

SECTION 11: PARTS LIST FOR MODEL 1027

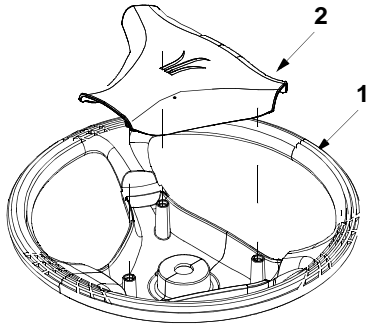

Ref. No.	Part No.	Description
1	731-2295	Steering Wheel
2	731-2296	Steering Wheel Insert

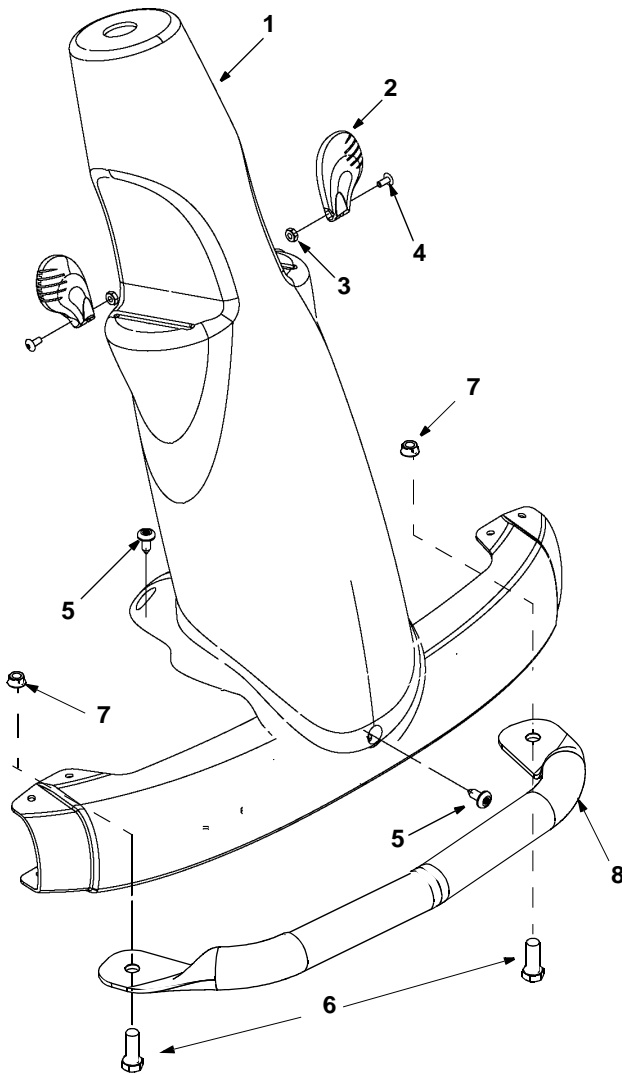

Ref. No.	Part No.	Description
1.	731-1919	Steering Column: Black
2.	731-1857	Control Knob
3.	712-0142	Hex Nut 8-32
4.	710-3217	Pan Head Machine Screw #8-32
5.	710-0599	Hex Screw TT 1/4-20 x .50"
6.	710-0514	Hex Screw 3/8-16 x 1.0"
7.	712-0431	Lock Nut
8.	749-1099-0716	Bumper Tube: Front, Yellow

Model 1027

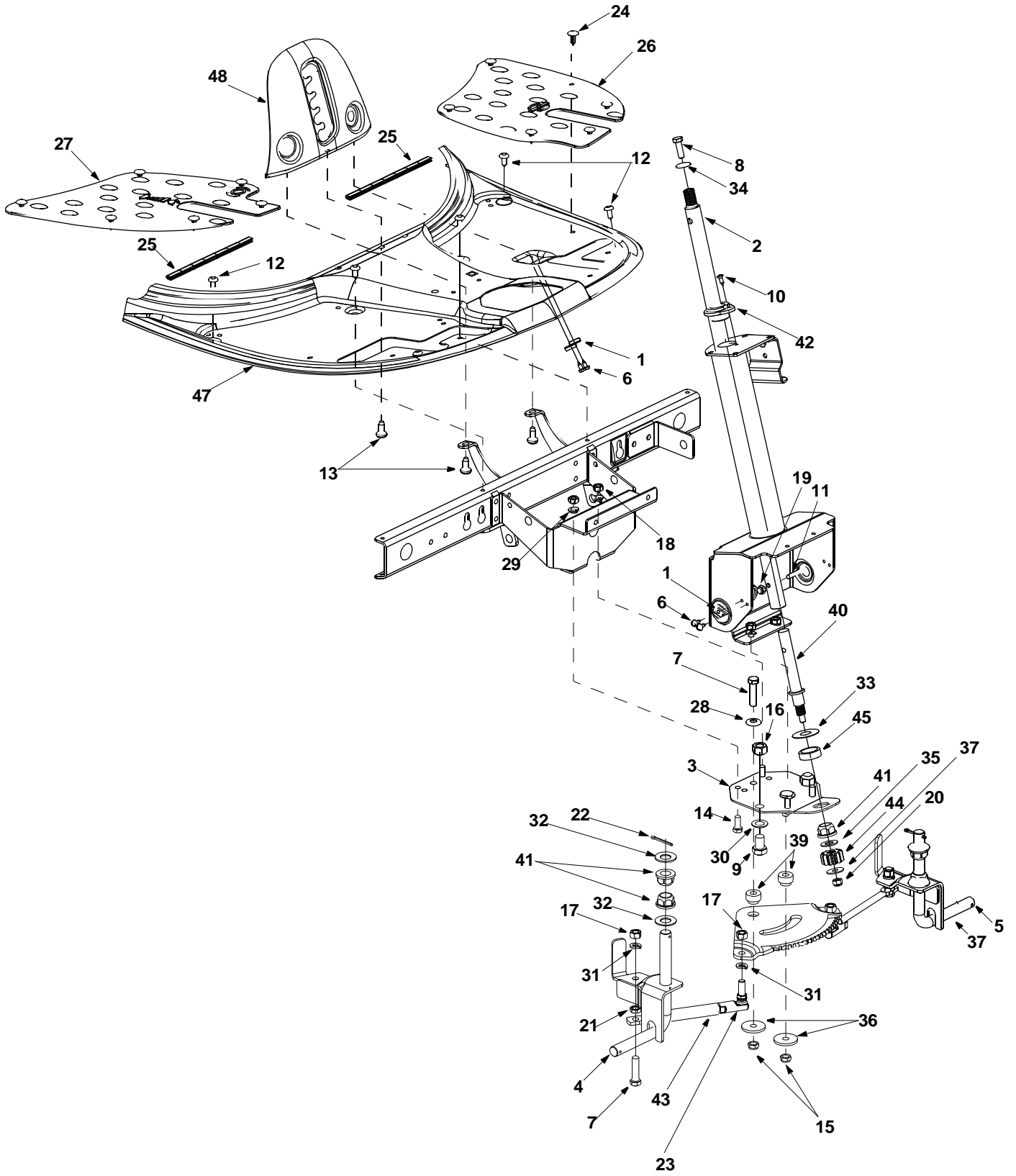

Model 1027

Ref. No.	Part No.	Description	Ref. No.	Part No.	Description
1.	17962	Switch Plate	25.	731-0511	Trim Strip
2.	650-0007	Steering Tube Assembly	26.	735-0265A	Floor Pad: LH
3.	683-0033A	Steering Support Bracket	27.	735-0266A	Floor Pad: RH
4.	683-0178A	Front Axle Assembly: RH	28.	736-0105	Bell Washer
5.	683-0179A	Front Axle Assembly: LH	29.	736-0119	Lock Washer
6.	710-0224	Hex Screw AB	30.	736-0160	Flat Washer
7.	710-0459A	Hex Screw 3/8-24 x 1.5" Gr.5 Sp.	31.	736-0169	Lock Washer
8.	710-0643	Lock Screw 5/16-18 x 1.0" Gr.5	32.	736-0187	Flat Washer
9.	710-0689	Hex Screw 1/2-13 x 0.75"	33.	736-0196	Flat Washer
10.	710-0837	Oval C-Sunk Screw #10-16 x 0.625"	34.	736-0242	Belleville Washer
11.	710-0958	Hex Screw 1/4-20 x 1.25 Gr.5 Sp.	35.	736-0272	Flat Washer
12.	710-1017	AB Screw 1/4-14 x 0.625"	36.	736-0320	Flat Washer
13.	710-1611	Self-Tapping Screw 5/16-18 x 0.75"	37.	736-3078	Flat Washer
14.	710-3008	Hex Screw 5/16-18 x 0.75"	38.	737-3007	Grease
15.	712-0116	Lock Nut 3/8-24	39.	738-0541	Spacer
16.	712-0206	Hex Nut 1/2-13	40.	738-3089A	Steering Adapter
17.	712-0241	Hex Nut	41.	741-0225	Hex Flange Bearing
18.	712-0267	Hex Nut	42.	741-0356	Bearing: Steering Column
19.	712-0324	Lock Nut 1/4-20	43.	747-0955	Tie Rod
20.	712-0411	Lock Nut	44.	748-0290	Pinion Gear
21.	712-0711	Jam Nut	45.	750-0532	Spacer
22.	714-0470	Cotter Pin	46.	783-0411	Gear: Steering Segment
23.	723-0156	Ball Joint	47.	783-0565B	Upper Frame Cover
24.	726-3046	Ratchet Clip	48.	783-0566A	Lift Plate

Model 1027

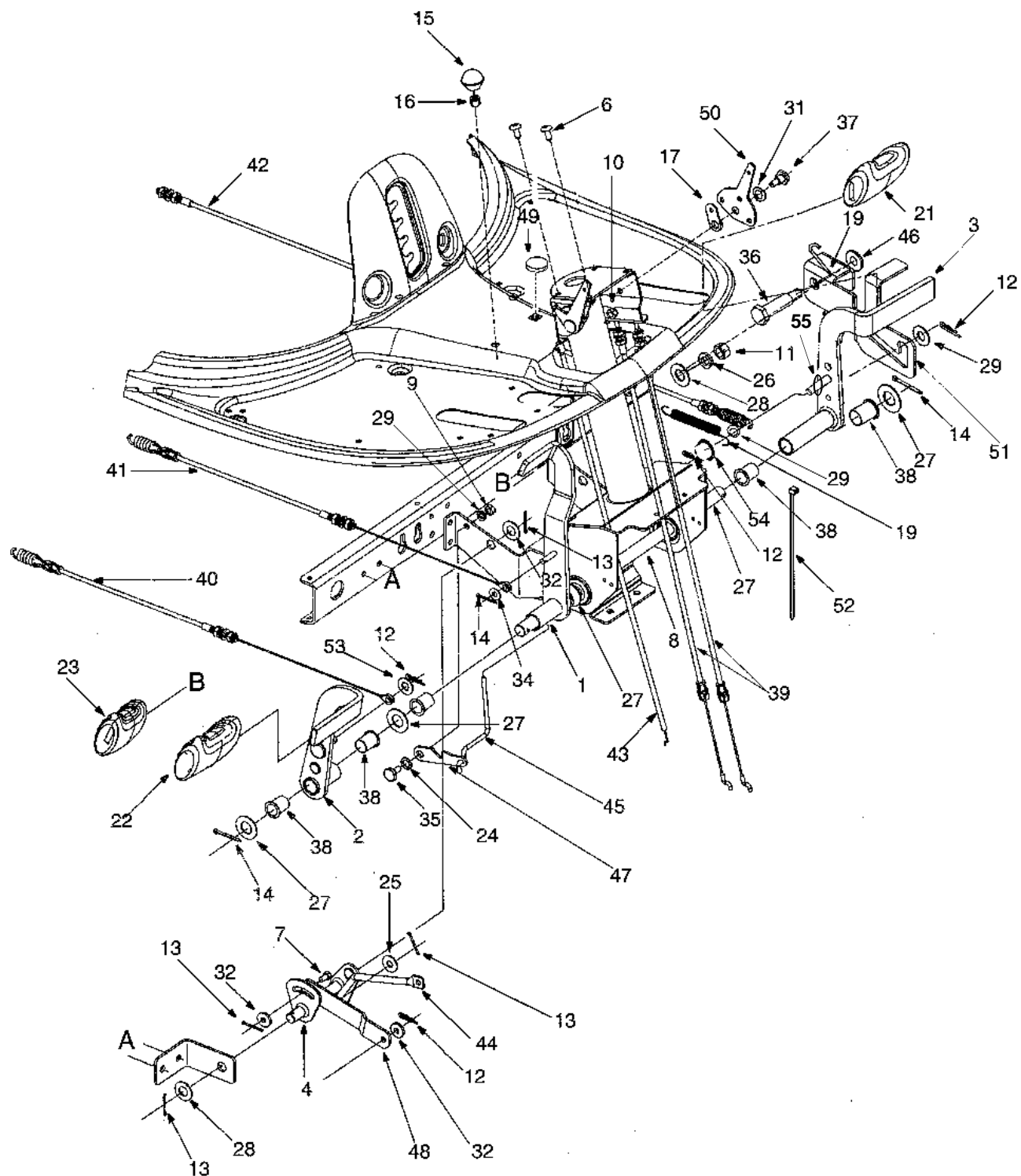

Model 1027

Ref. No.	Part No.	Description	Ref. No.	Part No.	Description
1.	683-0155	Brake Pedal Assembly	30.	736-0329	Lock Washer
2.	683-0156	Variable Pedal Assembly	31.	736-0608	Spring Washer
3.	683-0275	Deck Pedal Assembly	32.	736-3000	Flat Washer
4.	683-0161	Shift Cam Assembly	33.	736-3019	Flat Washer .531 X 1.062 X .134
6.	710-1017	Ab Screw 1/4-14 X .625	34.	736-3020	Flat Washer .271 X .630 X .065
7.	711-0701	Clevis Pin	35.	738-0255	Shoulder Screw .375 Dia X .18
8.	711-1156	Shaft	36.	738-0373	Shoulder Screw
9.	712-0287	Hex Nut 1/4-20	37.	738-0974	Shoulder Screw .375 X .380 X 1/4-20
10.	712-0324	Lock Nut 1/4-20	38.	741-0591	Flange Bearing
11.	712-3017	Hex Nut 3/8-16	39.	746-0935A	Shift Cable
12.	714-0104	Internal Cotter Pin	40.	746-0936	Variable Drive Cable
13.	714-0111	Hairpin Clip	41.	746-0937	Brake Cable
14.	714-0470	Hairpin Clip	42.	746-0940	Deck Cable
15.	720-0166	Ball Knob	43.	746-0964	Throttle Choke Cable: 67"
16.	731-0405	Snap-on Bushing	44.	747-0963	Brake Rod
17.	731-1913	Stop Lever	45.	747-0964	Brake Lock Out Rod
19.	732-0865	Torsion Spring	46.	750-0736	Shoulder Spacer
20.	732-0815	Extension Spring	47.	783-0473	Brake Lock Out Bracket
21.	735-0262	Deck Pad	48.	783-0525	Self-Propelled Pedal Link
22.	735-0261	Drive Pad	49.	726-0450	Plug Cap
23.	735-0263	Brake Pad	50.	783-0593A	Shift Lever
24.	736-0117	Flat Washer 3/8 X .620 X .033	51.	783-0794	Bracket: Lock-out Pedal
25.	736-0159	5/16 Washer	52.	726-0157	Cable Tie
26.	736-0169	Lock Washer	53.	736-0300	Flat Washer .406 I.D. x .875 O.D.
27.	736-0187	Flat Washer	54.	726-0100	Push Cap
28.	736-0272	Flat Washer .510 X 1.00 X .060	55.	736-0262	Flat Washer
29.	736-0133	Flat Washer .406 x 1.25 x .10			

Model 1027

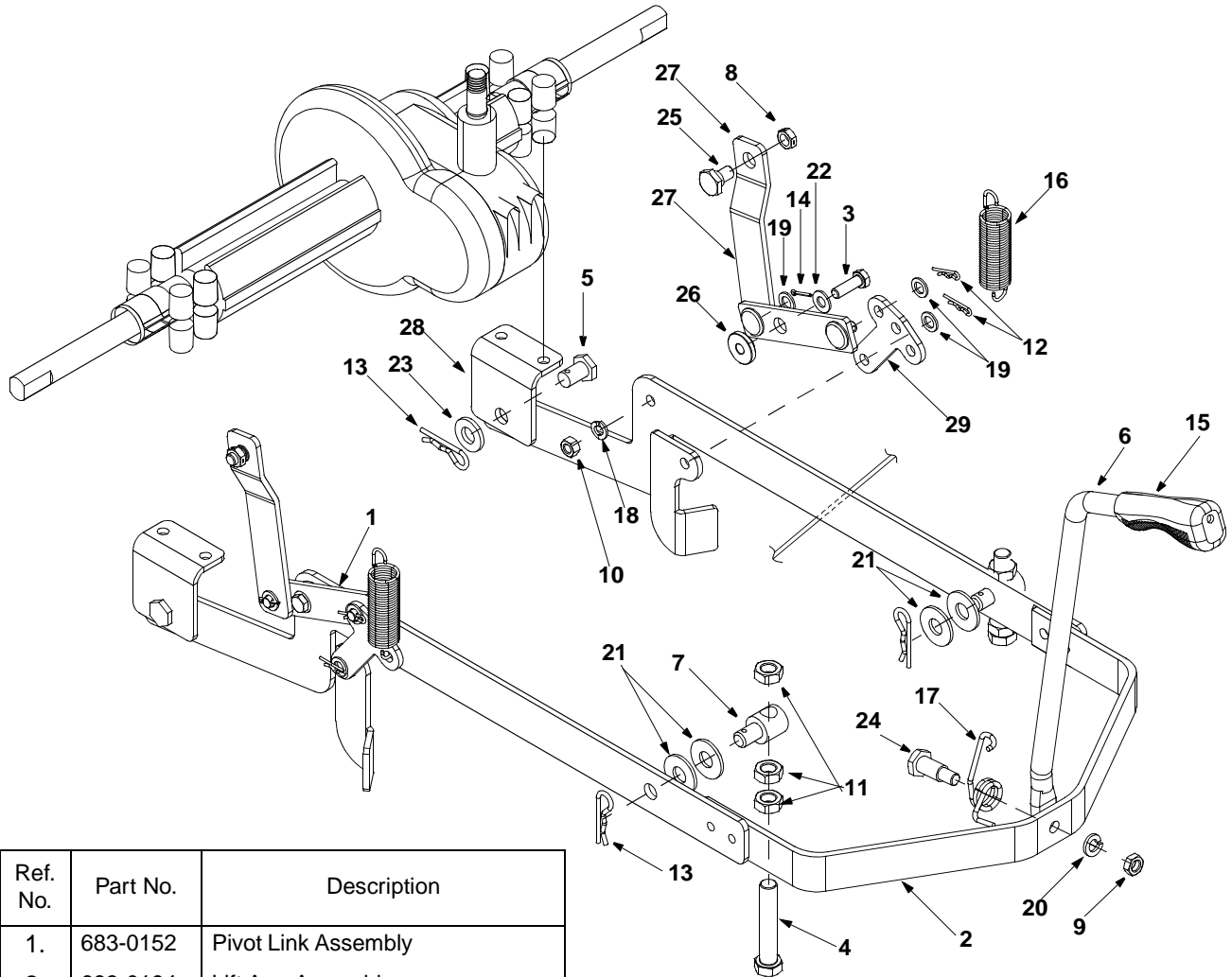

Ref. No.	Part No.	Description
1.	683-0152	Pivot Link Assembly
2.	683-0194	Lift Arm Assembly
3.	710-0376	Hex Screw 5/16-18 X 1.00 Gr.5
4.	710-3230	Hex Bolt 1/2-13 X 2.75 Gr.5 Special
5.	711-0332	Lift Bracket Pin
6.	711-1120	Lift Rod
7.	711-3319	Ferrule
8.	712-0266	Jam Nut
9.	712-3008	Jam Nut 3/8-16 Gr. 5
10.	712-3010	Hex Nut 5/16-18
11.	712-3048	Jam Nut
12.	714-0104	Cotter Pin
13.	714-0147	Cotter Pin
14.	714-3010	Cotter Pin
15.	720-0298	Handle Grip
16.	732-0829	Extension Spring
17.	732-0837	Torsion Spring

Ref. No.	Part No.	Description
18.	736-0119	Lock Washer 5/16
19.	736-0140	Flat Washer .385 I.D. x .620 O.D.
20.	736-0169	Lock Washer
21.	736-0257	Flat Washer
22.	736-0275	Flat Washer 5/16
23.	736-3019	Flat Washer
24.	738-0145	Shoulder Screw
25.	738-0183	Shoulder Screw
26.	738-0958	Shoulder Spacer
27.	783-0435	Upper Deck Link
28.	783-0437	Axle Bracket: Rear
29.	783-0440	Lower Link

Model 1027

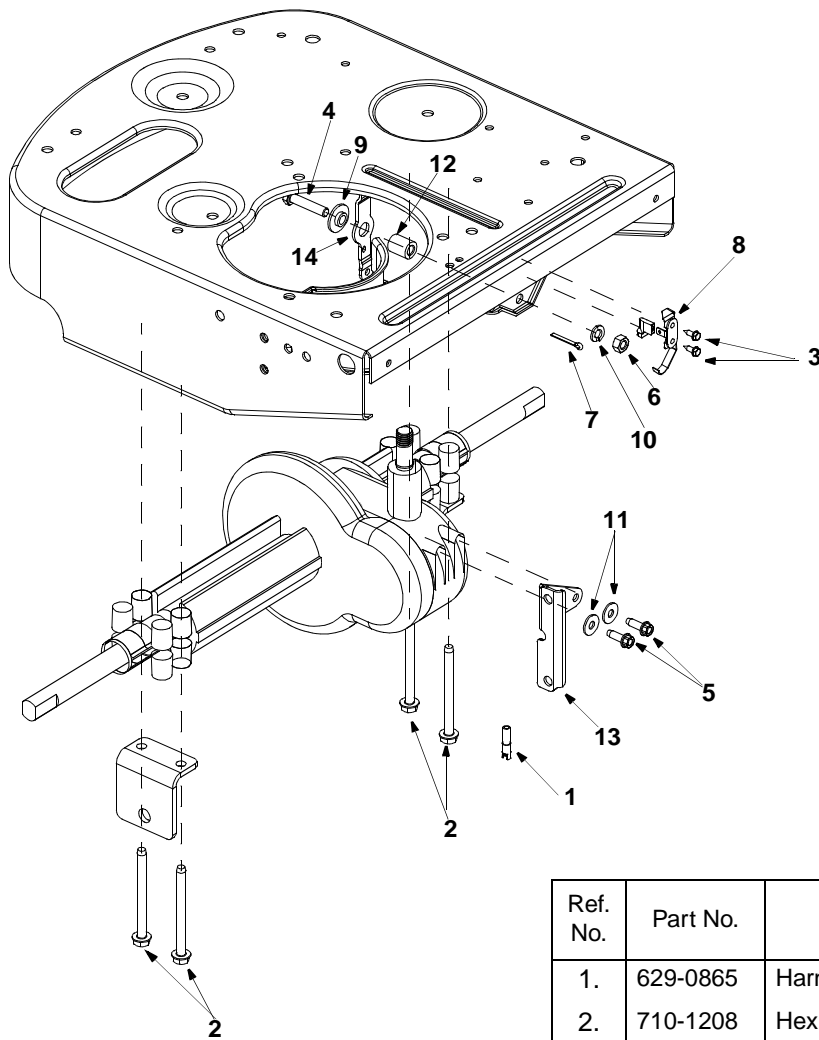

Ref. No.	Part No.	Description
1.	629-0865	Harness Assembly Adapter
2.	710-1208	Hex TT Screw 5/16-18 x 3.50
3.	710-0227	Hex Washer Head Self-Tap.Screw
4.	710-0805	Hex Screw 5/16-18 x 1.5 Gr. 5
5.	710-0642	Thd. Forming Scr. 1/4-20x .75
6.	712-3010	Hex Nut 5/16-18
7.	714-0115	Cotter Pin
8.	726-0320	Insulator Nut Plate
9.	736-0289	Shoulder Bushing
10.	736-0119	Lock Washer 5/16
11.	736-0173	Flat Washer .28 I.D. x .74 O.D. x .083
12.	750-1064	Spacer
13.	783-0591	Transaxle Bracket
14.	783-0433A	Shift Lever

Model 1027

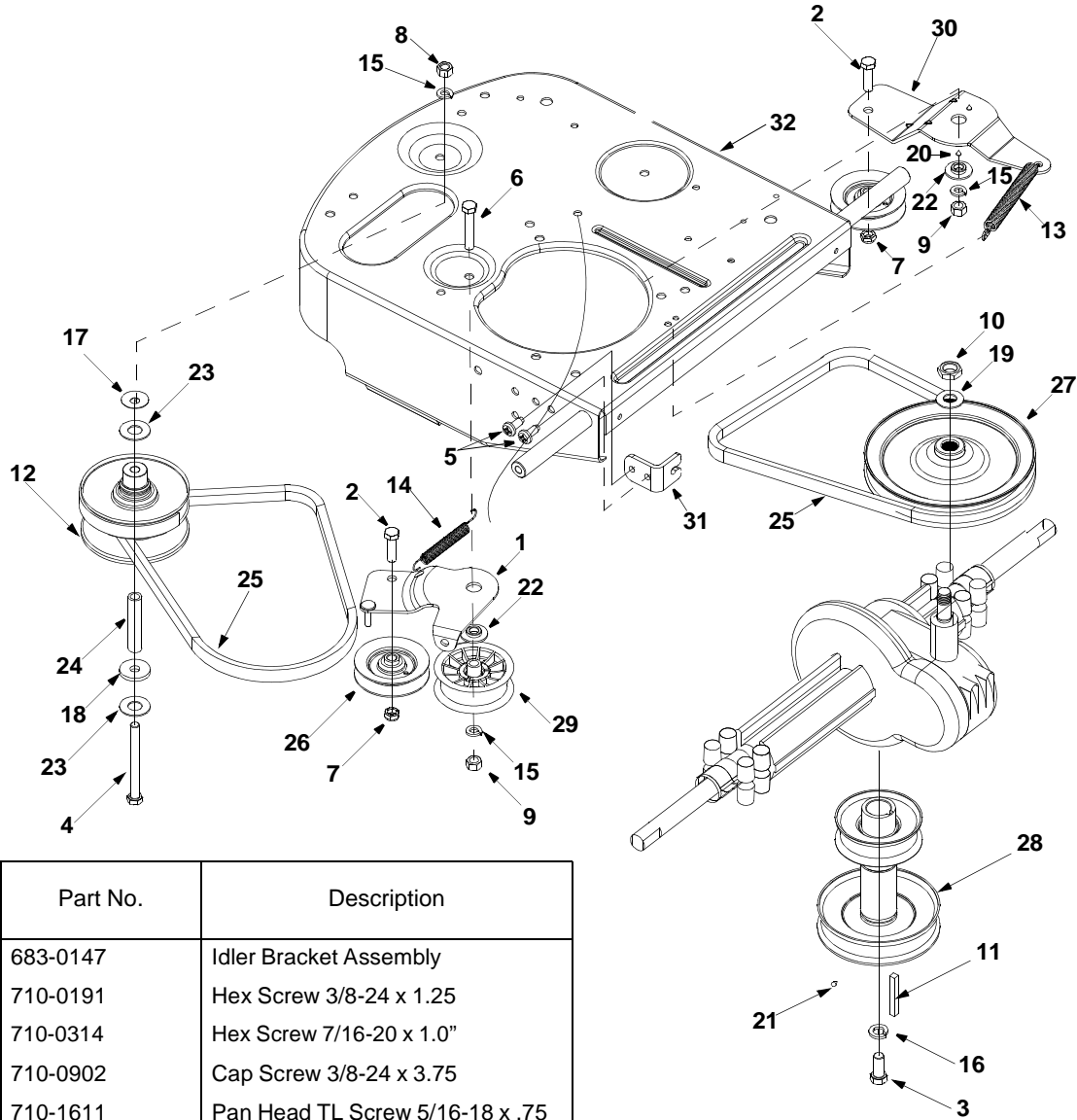

Ref. No.	Part No.	Description
1	683-0147	Idler Bracket Assembly
2	710-0191	Hex Screw 3/8-24 x 1.25
3	710-0314	Hex Screw 7/16-20 x 1.0"
4	710-0902	Cap Screw 3/8-24 x 3.75
5	710-1611	Pan Head TL Screw 5/16-18 x .75
6	710-3096	Hex Screw 3/8-16 x 2.0 Special
7	712-0116	Jam Lock Nut 3/8-24
8	712-0241	Hex Nut 3/8-24
9	712-3017	Hex Nut 3/8-16
10	712-3035	Hex Jam Nut 9/16-18 (Gr. 5)
11	714-0114	Square Key
12	717-0884	Variable Speed Pulley Assembly
13	732-0814	Extension Spring
14	732-0815	Extension Spring
15	736-0169	Lock Washer
16	736-0171	Lock Washer 7/16 I.D.
17	736-0219	Bell Washer .406 I.D. x 1.13 O.D.
18	736-0247	Flat Washer 3/8 x 1.25 O.D.
19	736-0427	Belleville Washer
20	737-0167	Grease

Ref. No.	Part No.	Description
21	737-0288	Grease
22	738-0968	Shoulder Spacer
23	741-0405	Bearing
24	750-0705	Spacer
25	754-0453	V-Belt
26	756-0116	Idler Pulley
27	756-0650	Transmission Pulley
28	756-0658	Engine Pulley
29	756-0981	Flat Idler Pulley
30	783-0528	Idler Bracket
31	783-0529	Cable Bracket
32	683-0149B-0716	Frame: Lower, Yellow

Model 1027

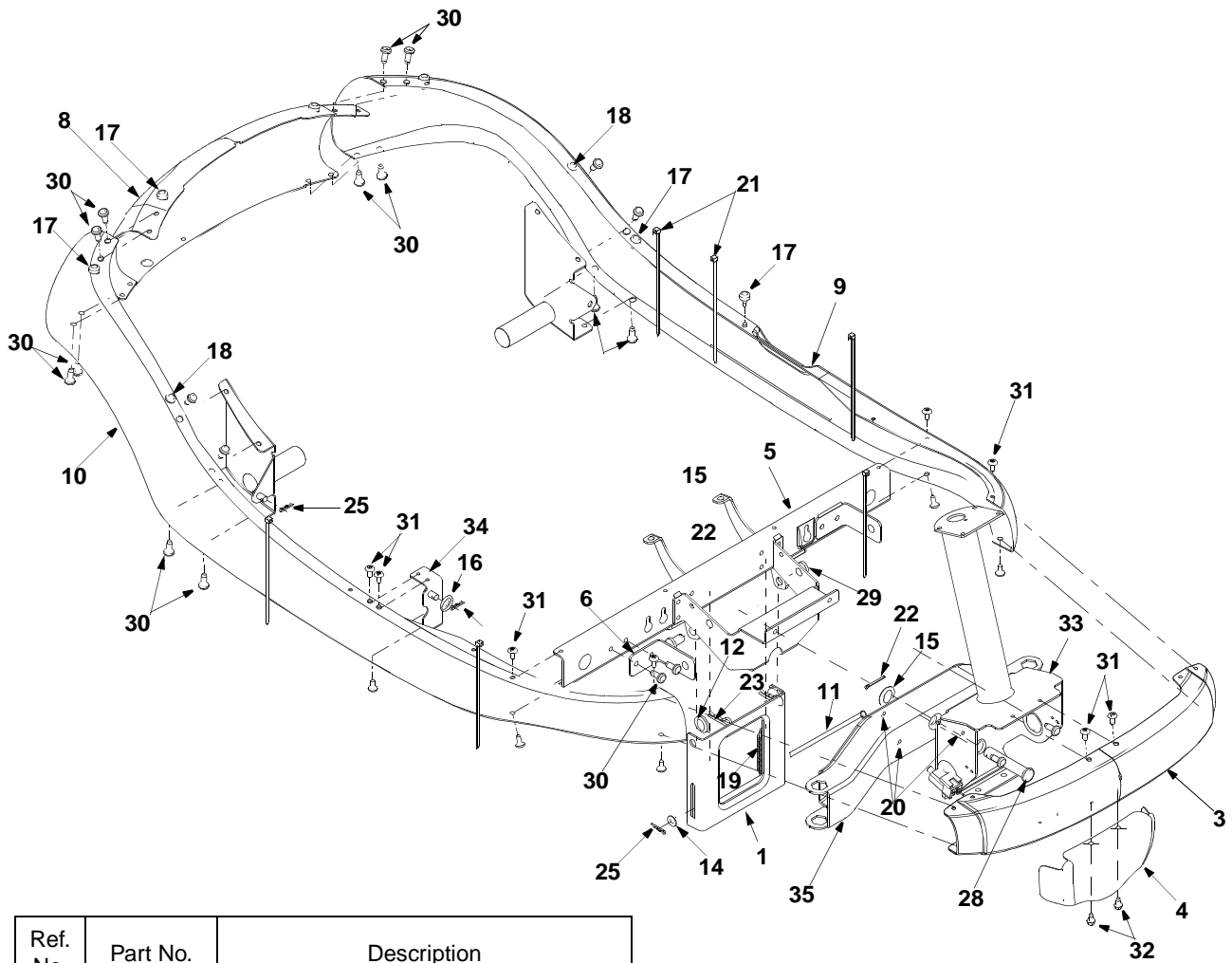

Ref. No.	Part No.	Description
1.	783-0605	Deck Stabilizing Bracket
3.	783-0564A	Front Frame: Upper
4.	783-0811-0716	Steering Gear Cover
5.	683-0264	Front Channel Assembly
6.	783-0554	Cam Bracket
8.	783-0414A	Frame Rail: Rear
9.	783-0413	Frame Rail—L.H.
10.	783-0412A	Frame Rail—R.H.
11.	747-0985	Deck Rod
12.	736-3019	Flat Washer .531 X 1.062 X .134
14.	736-0275	Flat Washer 5/16
15.	736-0187	Flat Washer .64 I.D. X 1.24 X .06
16.	736-0101	Flat Washer 3/8 X 1.00 X .030
17.	735-0271	Rubber Bumper
18.	735-0199A	Rubber Bumper
19.	732-0829	Extension Spring

Ref. No.	Part No.	Description
20.	737-3007	Grease
21.	725-0157	Cable Tie
22.	714-0470	Hairpin Clip
23.	714-0147	Hairpin Clip
25.	714-0104	Hairpin Clip
28.	711-1165	Clevis Pin
29.	711-0332	Lift Bracket Pin
30.	710-1611	TT Screw 5/16-18 x .75
31.	710-1017	Torx Mach. AB Scr. 1/4-14 x 0.625"
32.	710-0599	Hex TT Screw 1/4-20
33.	683-0163A	Steering Support Bracket
34.	683-0160	Pivot Bracket Ass'y.: Hood
35.	683-0142	Pivot Bar Assembly

Model 1027

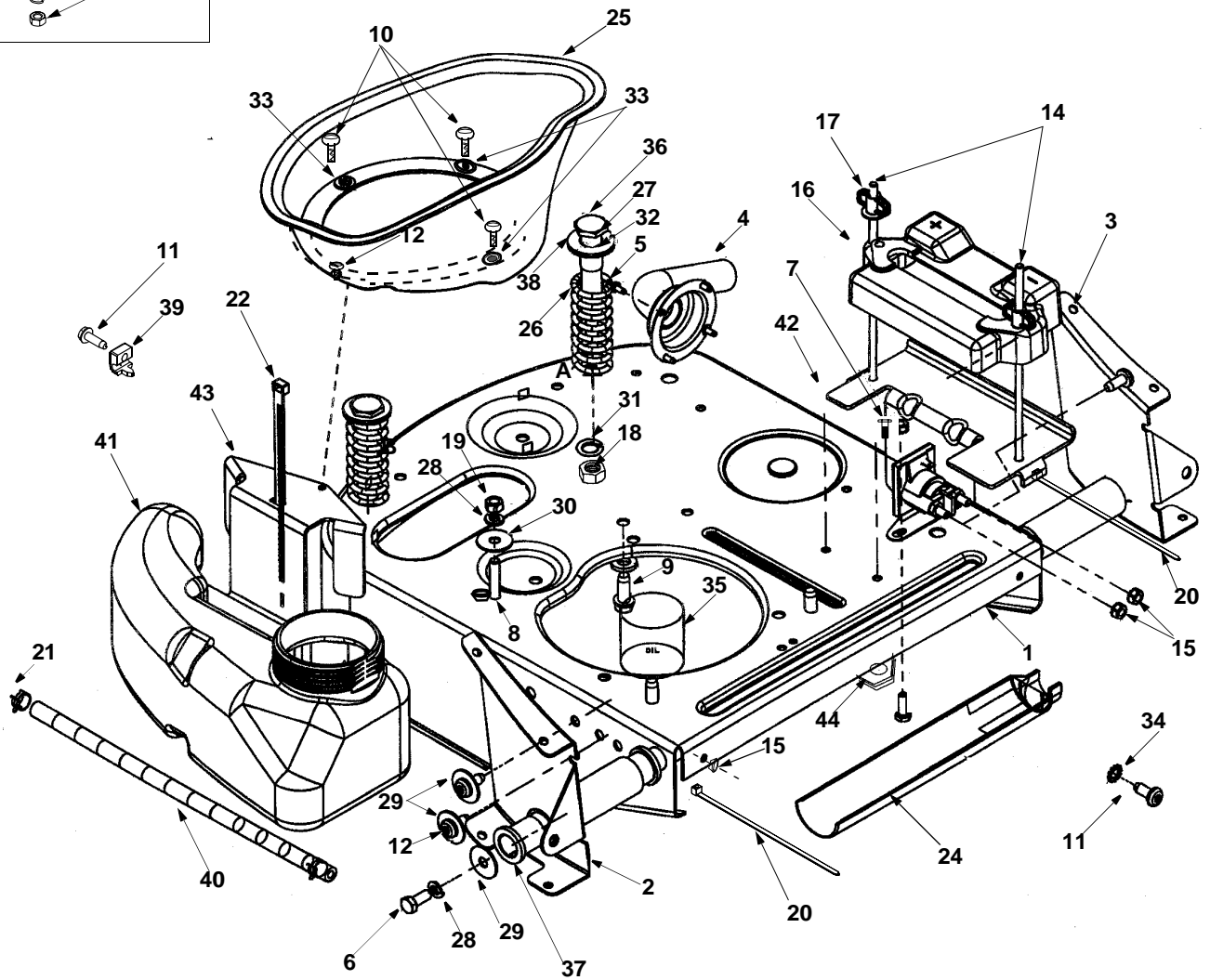
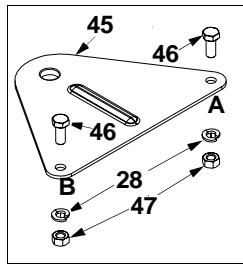

Model 1027

Ref. No.	Part No.	Description	Ref. No.	Part No.	Description
1.	683-0149B	Frame Assembly	25.	731-1945	Engine Duct
2.	683-0190A	Frame Rail Support: RH	26.	732-3080	Compression Spring
3.	683-0191A	Frame Rail Support: LH	27.	735-0273	Rubber Washer
4.	683-0192	Muffler Pipe Extension	28.	736-0119	Lock Washer
5.	710-0148	Hex Fl. Screw #8-32 x 0.375	29.	736-0123	Flat Washer
6.	710-0157	Hex Screw 5/16-24 x .75" Gr.5	30.	736-0159	5/16 Washer
7.	710-0599	Self-Tapping Screw	31.	736-0169	Lock Washer
8.	710-0624	Hex Screw 5/16-24 x 1.5" Gr.5	32.	736-0188	Flat Washer
9.	710-0654A	TT Screw 3/8-16 x 1.0"	33.	736-0400	Flat Washer
10.	710-0871	Hex Slot Sems Screw #10-32 x 0.38	34.	736-0607	Lock Washer
11.	710-1237	Hex Washer TT Screw #10-32 x 0.625"	35.	737-0169	Motor Oil
12.	710-1611	TT Screw 5/16-18 x 0.75"	36.	738-0960	Shoulder Screw
13.	710-1653	Machine Screw #10-32 x 0.5"	37.	741-0516	Flange Bearing
14.	711-0222A	Battery Hold-Down Rod	38.	741-0591	Flange Bearing
15.	712-0271	Hex Sems Nut 1/4-20	39.	751B213146	Throttle Casing Clamp
16.	712-0291	Lock Nut 1/4-20	40.	751-0535	Fuel Line Hose
17.	712-0397	Wing Nut with Bell Washer	41.	751-0656	Fuel Tank
18.	712-3017	Hex Nut	42.	783-0624	Battery Bracket
19.	712-3057	Hex Nut 5/16-24 Gr.5	43.	783-0630	Fuel Tank Bracket
20.	725-0157	Cable Tie	44.	783-0809B	Transaxle Support Bracket
21.	726-0205	Hose Clamp	45.	783-0561	Hitch Plate
22.	726-0209	Cable Tie	46.	710-3008	Hex Bolt: 5/16-18 x .75"
23.	731-0708	Battery Cover	47.	712-0267	Hex Nut
24.	731-1682A	Oil Drain Sleeve			

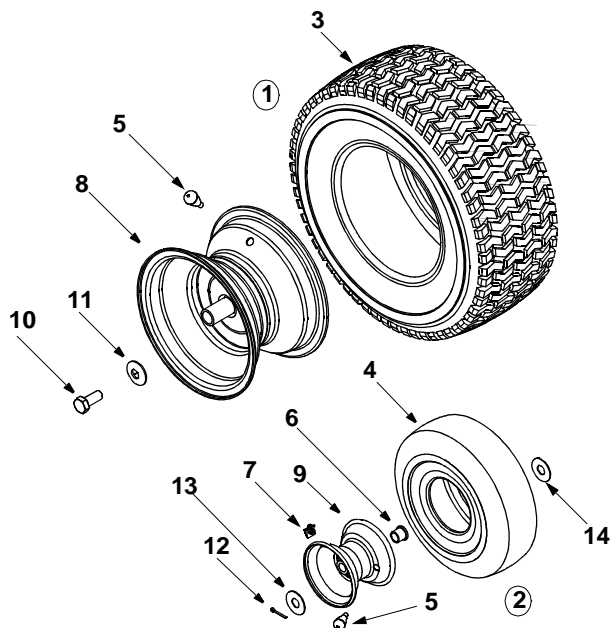

Ref. No.	Part No.	Description
1.	634-0139	Rear Wheel Compl.
2.	634-0169	Front Wheel Compl.
3.	734-1727	Rear Tire
4.	734-1382	Front Tire
5.	734-0255	Valve: Tubeless Air
6.	737-0211A	Grease Fitting
7.	741-0353	Flange Bearing
8.	634-0138-0499	Rim Assembly: Beige
9.	734-1455A-0499	Rim Assembly: Beige
10.	710-0627	Hex Bolt 5/16-24 x .75"
11.	736-0242	Beleville Washer
12.	714-0115	Cotter Pin
13.	736-0285	Flat Washer
14.	736-0366	Flat Washer
15.	731-0484A	Hub cap (not shown)

Model 1027

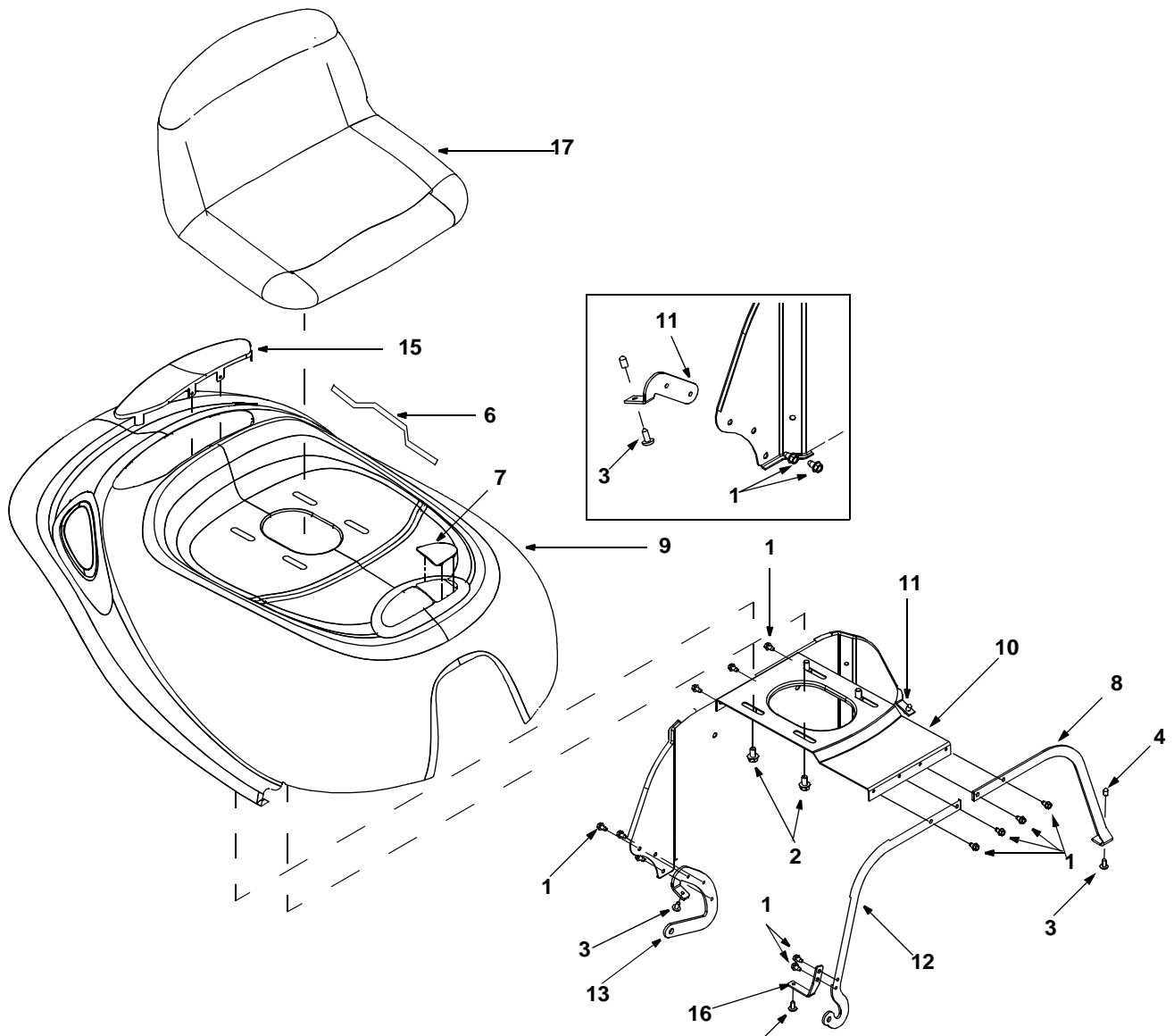

Ref. No.	Part No.	Description	Ref. No.	Part No.	Description
1.	710-0599	TT Screw 1/4-20 x 0.5	10.	783-0446	Plate: Hood
2.	710-0870	TT Screw 3/8-16 x 0.62	11.	783-0447	Hood Bracket
3.	710-1017	Torx AB Screw 1/4-14 x 0.625	12.	783-0448	Hood Bracket: Reinforcement
4.	720-0238	Rod End Grip	13.	783-0449	Hinge Bracket: Rear
6.	731-0511	Trim Strip	14.	783-0451A	Pivot Plate: Rear Hood
7.	731-1691	Grass Bag Lens	15.	783-0545	Hood Screen
8.	783-0410	Bracket Reinforcement: Hood	16.	783-0562	Hinge Bracket: Front
9.	783-0445-0499	Hood: Beige	17.	757-0381	Seat

Model 1027

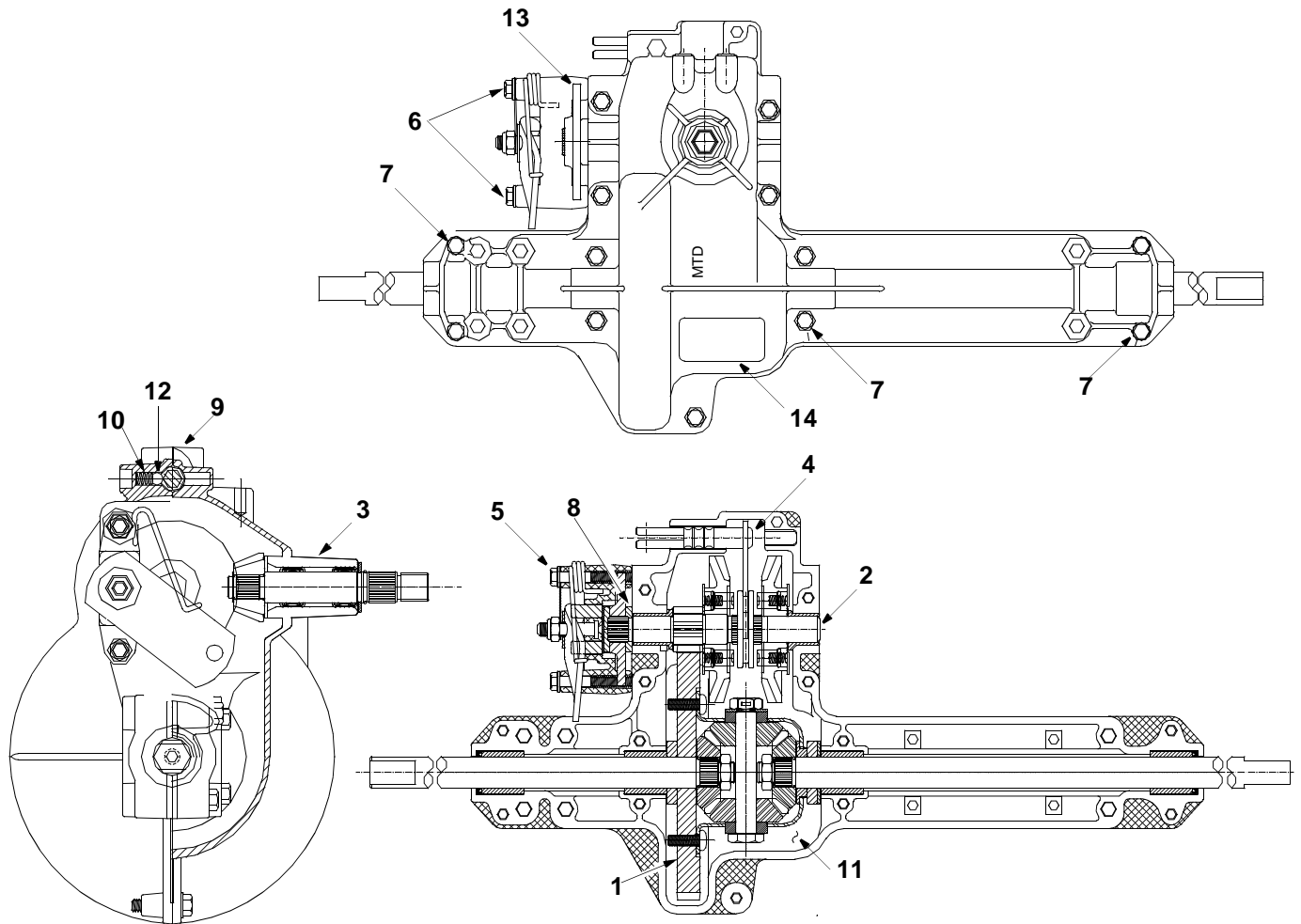

Ref. No.	Part No.	Description
1.	618-0232	Differential Assembly: Single Speed
2.	618-0248	Drive Shaft assembly: LH Brake
3.	618-0072B	Upper Housing Assembly
4.	611-0114	Detent Shaft Assembly
5.	661-0006	Brake Yoke Assembly: LH
6.	710-1206	Hex Washer Hd. TT Screw 1/4-20 x 2.37 Gr.5
7.	710-1325	Hex Washer Hd. TT Screw 1/4-20 x 1.65
8.	717-0678	Brake Puck
9.	719-0313B	Lower Housing
10.	732-0863	Spring Detent
11.	737-0148	Grease
12.	741-0862	Ball Detent
13.	761-0202	Brake Disc
14.	777-6318	Label

Model 1027

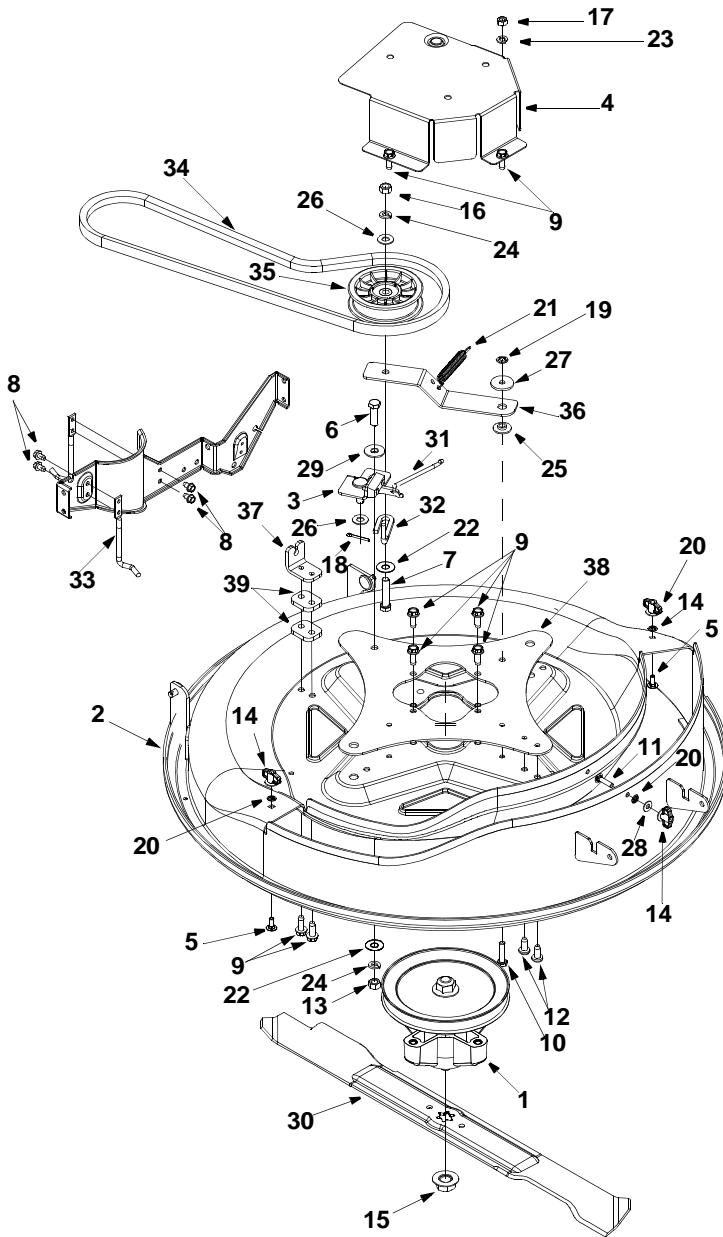

Ref. No.	Part No.	Description
9.	710-0650	Self-Tapp. Screw 5/16-18 x .75
10.	710-0672	Hex Cap Scr. 5/16-24 x 1.25
11.	710-0932	Carriage Screw
12.	710-1611	Torx Screw 5/16-18 x .75
13.	712-0241	Hex Nut 3/8-24
14.	712-0397	Wing Nut With Bell Washer
15.	712-0417A	Flange Nut 5/8-18
16.	712-3017	Hex Nut 3/8-16
17.	712-3057	Hex Nut 5/16-24
18.	714-0115	Cotter Pin
19.	726-0201	Speed Nut
20.	726-0233	Push Nut
21.	732-0429A	Extension Spring
22.	736-0101	Flat Washer 3/8 x 1.00 x .030
23.	736-0119	Lock Washer 5/16
24.	736-0169	Lock Washer 3/8
25.	736-0289	Bushing
26.	736-0300	Flat Washer .406 x .875 x .059
27.	736-0343	Flat Washer .330 x 1.25 x .120
28.	736-3020	Flat Washer
29.	738-0968	Spacer
30.	742-0651	Three-in-one Blade
31.	747-0957	Link Rod
32.	747-0972	Belt Keeper
33.	747-1172	Belt Keeper
34.	754-0754	V Belt
35.	756-0627	Flat Idler Pulley
36.	783-0463	Idler Bracket
37.	783-0529	Cable Bracket
38.	783-0569A	Deck Plate
39.	783-0781	Deck Skirt
40.	783-0594	Deck Cable Bracket

Ref. No.	Part No.	Description
1.	618-0250	Spindle Assembly
2.	683-0150C-0716	Deck Assembly: Yellow
3.	683-0159	Brake Bracket Assembly
4.	683-0173	Deck Belt Cover
5.	710-0134	Carriage Screw 1/4-20 x .62
6.	710-0191	Hex Bolt 3/8-24 x 1.25 Grade 8
7.	710-0347	Hex Screw 3/8-16 x 1.75 Gr. 5
8.	710-0599	Self-Tapp. Screw 1/4-20 x .5

Model 1027

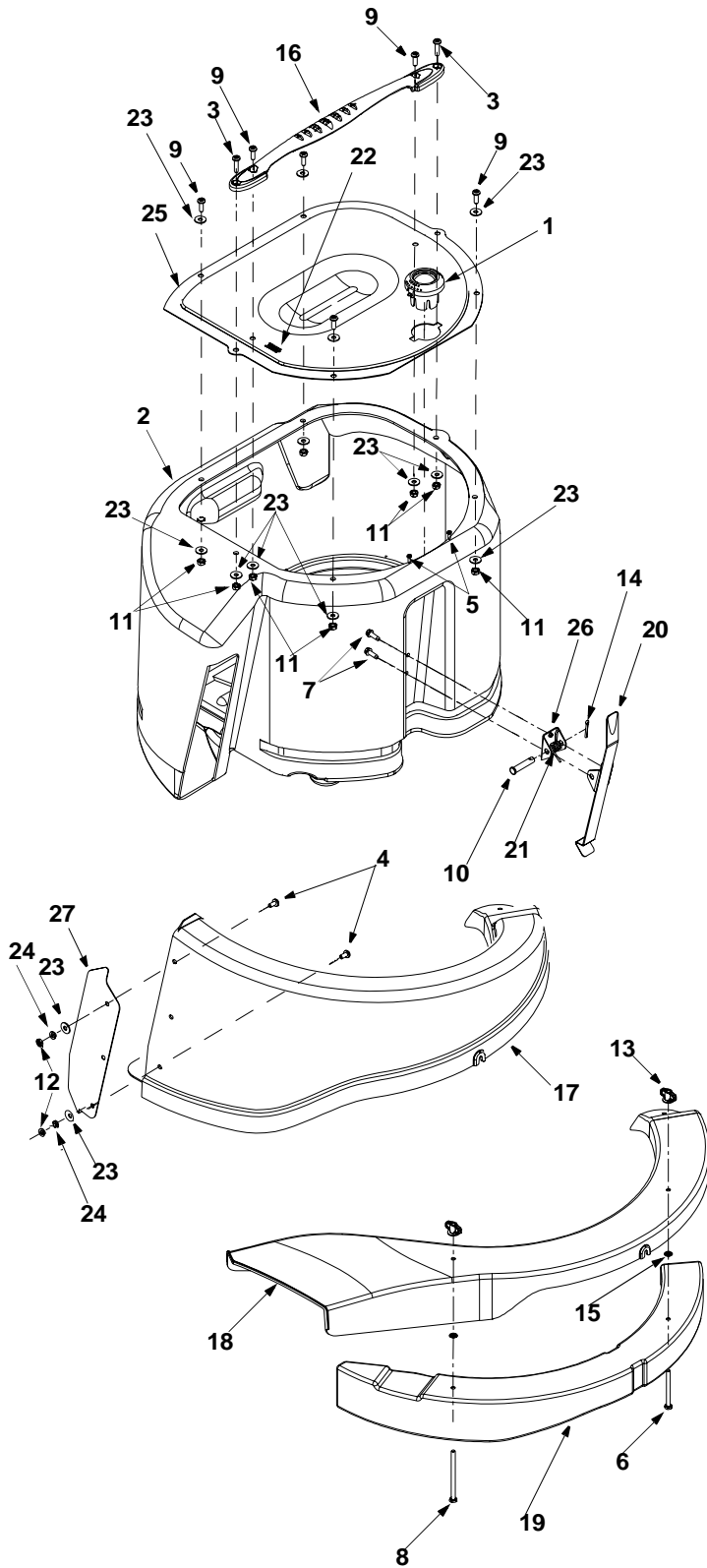

Ref. No.	Part No.	Description
1	631-0060	Flow Indicator Assembly
2	631-0080	Grass Bag Assembly
3	710-0166	Machine Screw 1/4-20 x 1.0
4	710-0286	Machine Screw 1/4-20 x 0.5"
5	710-0456	Hex Screw #10-16 x 0.5"
6	710-0564	Hex Screw 1/4-20 x 2.75"
7	710-0642	Self-Tapping Screw 1/4-20 x 0.75"
8	710-0825	Hex Screw 1/4-20 x 3.75"
9	710-0924	Machine Screw 1/4-20 x 0.75"
10	711-0415	Clevis Pin
11	712-0271	Hex Sems Nut 1/4-20
12	712-0298	Jam Nut
13	712-0397	Wing Nut
14	714-0115	Cotter Pin
15	726-0271	Speed Nut
16	731-1441	Bag Handle
17	731-1743A	Discharge Chute: Grass Bag
18	731-1744	Side-Discharge Chute
19	731-1745A	Mulching Plug
20	732-0839	Bag Release Lever
21	732-0841	Torsion Spring
22	732-0854	Clip Spring
23	736-0173	Flat Washer
24	736-0329	Lock Washer
25	783-0544A	Grass Bag Screen
26	783-0575A	Pivot Bracket
27	783-0645	Deflector Plate

Model 1027

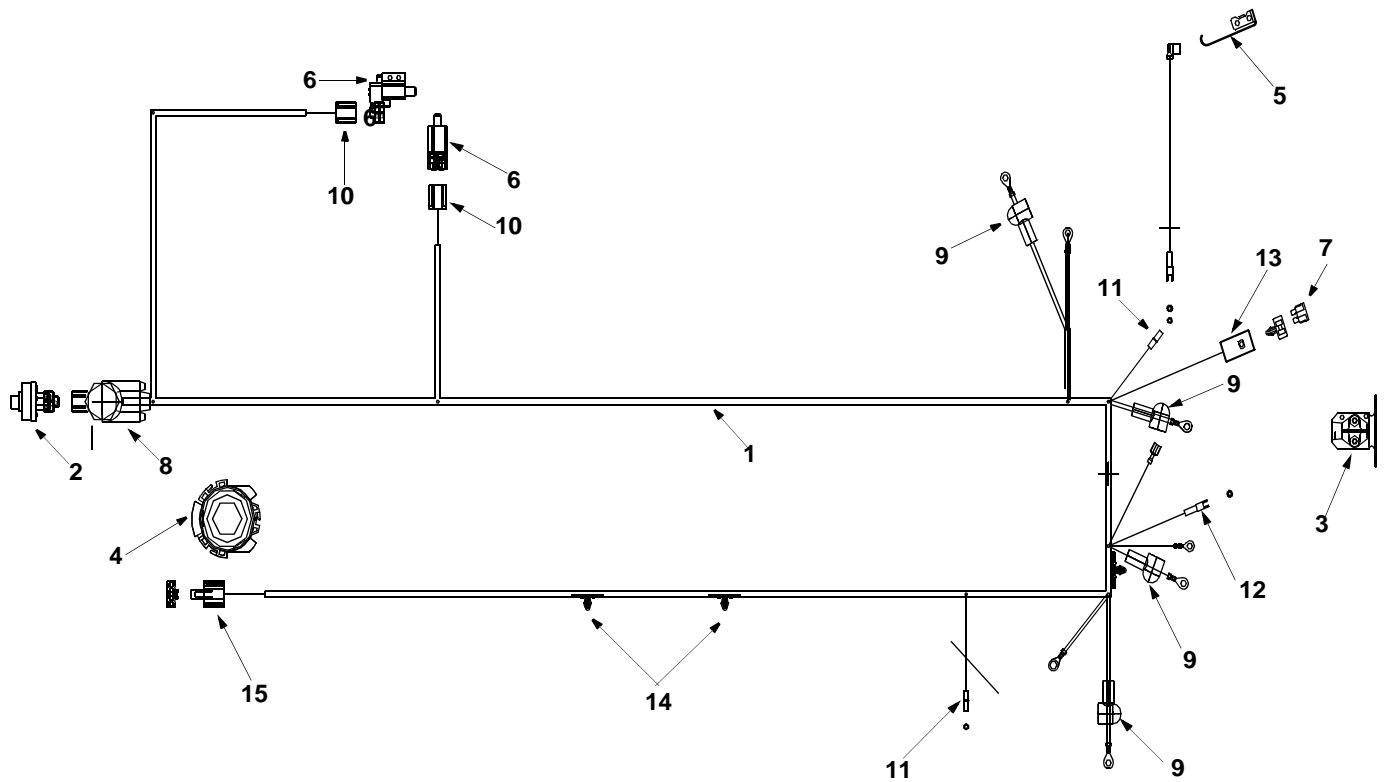

Ref. No.	Part No.	Description
1.	629-0945	Harness Assembly w/o relays
2.	725-0267	Ignition Switch: 5 Pin
	725-1345	Ignition Key (not shown)
3.	725-1426	Solenoid: 12 V. 100 amp.
4.	725-1462	Seat Switch
5.	725-1643	Spring Switch
6.	725-1657A	Interlock Switch
7.	725-1381	Fuse: 20 amp.
8.	725-1726	Battery Cover
9.	725-3237	Battery Cover: Red
10.	729-0125	Connector
11.	729-0139	Connector
12.	729-0171	Connector
13.	729-0357	Fuse Holder w/Clip
14.	729-0359	Harness Clip
15.	729-1108	Connector

Your Notes

Date	Comments

Your Notes

Date	Comments

MANUFACTURER'S LIMITED WARRANTY FOR:



TWO-YEAR RESIDENTIAL ONE-YEAR COMMERCIAL

Proper maintenance of your Cadet equipment is the owner's responsibility. Follow the instructions in your operator's manual for correct lubricants and maintenance schedule. Your Cub Cadet dealer carries a complete line of quality lubricants and filters for your equipment's engine, transmission, chassis and attachments.

Riding mowers, lawn tractors, Cadet attachments and home maintenance products

This limited warranty for residential users, covers any defect in materials or workmanship in your Cadet equipment for two years from the date of purchase for the first user purchaser. We will replace or repair any part or parts without charge through your authorized Cub Cadet dealer.

Batteries have a one-year prorated limited warranty with 100% replacement during the first three months.

V-belts for either the traction drive or any attachments are covered for one year only.

Cadet equipment used commercially is warranted for one year only.

(Commercial use is defined as either having hired operators or used for income producing purposes.)

Items not covered

The warranty does not cover routine maintenance items such as lubricants, filters (oil, fuel, air and hydraulic), cleaning, tune-ups, brake and/or clutch inspection, adjustments made as part of normal maintenance, blade sharpening, set-up, abuse, accidents and normal wear. It does not cover incidental costs such as transporting your equipment to and from the dealer, telephone charges or renting a product temporarily to replace a warranted product.

There is no other express warranty.

How to obtain service

Contact your authorized Cub Cadet servicing dealer who sold you your Cadet equipment. If this dealer is not available, see the Consumer Yellow Pages under "lawn mowers" for the name of a dealer near you.

If you need further assistance in finding an authorized Cadet servicing dealer, contact:

**Cub Cadet Corporation
Post Office Box 368023
Cleveland, Ohio 44136**

How does state law apply?

This limited warranty gives you specific legal rights, and you may also have other rights which vary from state to state.