

Cub Cadet

Operator's Manual

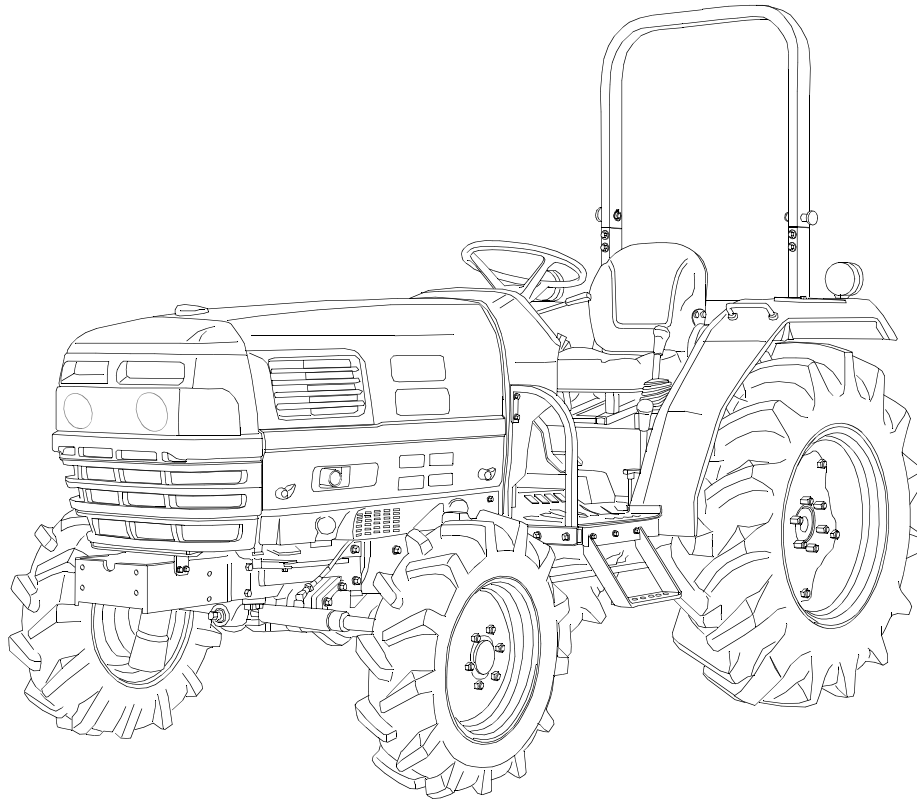

SERIES 8000 COMPACT TRACTOR MODEL 8454

IMPORTANT: READ SAFETY RULES AND INSTRUCTIONS CAREFULLY

CUB CADET LLC P.O. BOX 361131 CLEVELAND, OHIO 44136-0019 [www.cubcadet.com]

PRINTED IN U.S.A.
ECO

FORM NO. 769-00708
(03/03)

TABLE OF CONTENTS

TO THE OWNER	2
CALLING SERVICE INFORMATION	2
RECORDING MODEL AND SERIAL NUMBER INFORMATION	3
IMPORTANT SAFE OPERATION PRACTICES	4
SAFETY LABELS	10
SECTION 1: CONTROLS AND FEATURES	12
SECTION 2: OPERATION	20
SECTION 3: ADJUSTMENTS	30
SECTION 4: TRACTOR MAINTENANCE	34
SECTION 5: TROUBLESHOOTING	50
SECTION 6: SPECIFICATIONS	54
WARRANTY	56

TO THE OWNER

This Operator's Manual is an important part of your new tractor. The information contained in this manual has been prepared in detail to help you better understand the features, correct operation, adjustments, and maintenance of your tractor. The performance and dependability of this tractor rely greatly on the manner in which it is operated and maintained. Therefore, it is recommended that all operators of the tractor carefully read this manual and fully understand its operation. Also keep the manual available for reference to ensure proper operation, and that maintenance procedures are performed as scheduled to assure the tractor's optimal mechanical condition.

NOTE: *All references to LEFT, RIGHT, FRONT, and REAR, unless specifically stated otherwise, indicate that relative position on the tractor when facing forward while seated in the operator's seat.*

Your authorized *Cub Cadet* dealer is interested in the performance you receive from your tractor, and with the maintenance needed to ensure the satisfactory operation of your tractor. The dealer has trained service personnel familiar with the latest servicing information, is equipped with the latest tools, and has a complete line of genuine *Cub Cadet* service parts which assure proper fit and high quality.

CALLING SERVICE INFORMATION

The engine manufacturer is responsible for all engine-related issues with regards to performance, power-rating, and specifications.

If you have difficulties with the tractor and/or equipment; have any questions regarding the operation or maintenance of this equipment; or desire additional information not found in this manual, contact your dealer. If you need assistance in locating a dealer in your area, contact the Customer Dealer Referral Line by calling:

1-877-282-8684

Before calling your dealer, make sure that you have your model number(s) and manufacturing date available for the dealer.

RECORDING MODEL AND SERIAL NUMBER INFORMATION

Product identification plates are provided for major components of your tractor. The numbers on these plates are important if your tractor should require dealer service, or if you need additional information on your tractor. Prior to using your tractor for the first time, record the numbers from the identification plates in the appropriate spaces provided below.

- The tractor model plate is located on the transmission housing on the left side of the tractor.
- The engine serial number is located on the right side of the engine crankcase.
- The transmission serial number is located on the left side of the transmission case near the left brake case.
- The ROPS information plate is located on the ROPS.

Tractor Model Plate:

Model Number

Serial Number

Engine Information:

Engine Serial No.

Transmission Information:

Transmission Serial No.

ROPS Information:

ROPS Serial No.

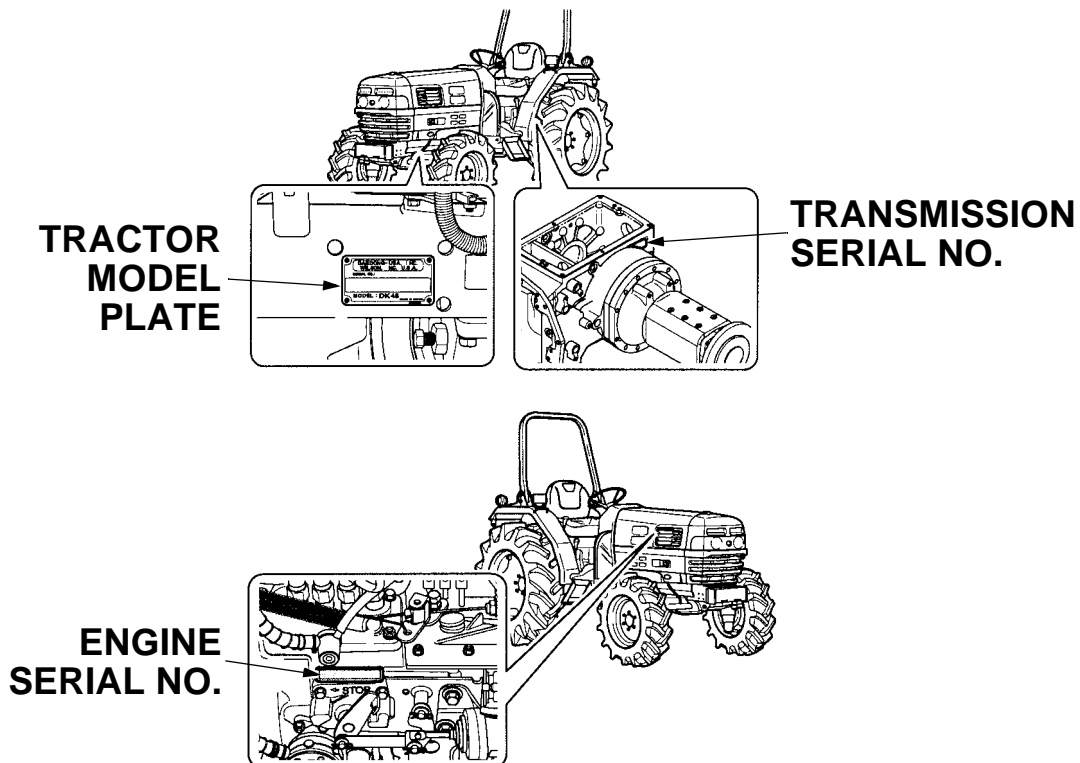

IMPORTANT SAFE OPERATION PRACTICES



WARNING: THIS SYMBOL POINTS OUT IMPORTANT SAFETY INSTRUCTIONS WHICH, IF NOT FOLLOWED, COULD ENDANGER THE PERSONAL SAFETY AND/OR PROPERTY OF YOURSELF AND OTHERS. READ AND FOLLOW ALL INSTRUCTIONS IN THIS MANUAL BEFORE ATTEMPTING TO OPERATE YOUR UNIT. FAILURE TO COMPLY WITH THESE INSTRUCTIONS MAY RESULT IN PERSONAL INJURY. WHEN YOU SEE THIS SYMBOL, HEED ITS WARNING.



WARNING: The engine exhaust, some of its constituents, and certain vehicle components contain or emit chemicals known to the State of California to cause cancer, birth defects or other reproductive harm.



WARNING: This unit is equipped with an internal combustion engine and should not be used on or near any unimproved forest-covered, brush-covered or grass-covered land unless the engine's exhaust system is equipped with a spark arrester meeting applicable local or state laws (if any). If a spark arrester is used, it should be maintained in effective working order by the operator. In the State of California the above is required by law (Section 4442 of the California Public Resources Code). Other states may have similar laws. Federal laws apply on federal lands. A spark arrester for the muffler is available through your nearest engine authorized service dealer or contact the service department, P.O. Box 361131Cleveland, Ohio 44136-0019.



DANGER: Your tractor was built to be operated according to the rules for safe operation in this manual. As with any type of power equipment, carelessness or error on the part of the operator can result in serious injury. To help prevent accidents, read and take the following precautions before operating this tractor. Failure to observe the following safety instructions could result in serious injury or death.

1. GENERAL OPERATION

- Read, understand, and follow all instructions in the operator's manual and on the machine before starting. Keep this manual in a safe place for future and regular reference.

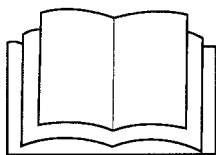

- Only allow responsible individuals familiar with the instructions to operate the machine. Know controls and how to stop the machine quickly.
- Pay special attention to the warning and caution labels affixed to the tractor.
- Keep all safety decals clean and readable. Replace any missing, illegible, or damaged safety decals.

- Use the handholds and step plates when getting on and off the tractor to help prevent accidental falls. Keep the steps and running boards clear of mud and debris.
- Before driving the tractor in reverse, check to see that there are no people or obstacles around.

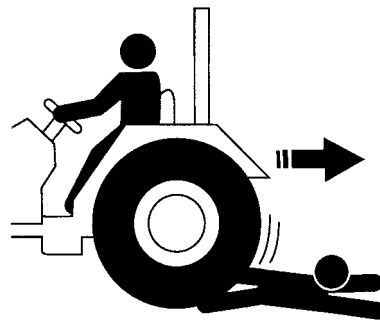

- Watch where you are going at all times. Watch for and avoid all obstacles. Be alert at row ends, near trees and other obstructions.

- Never operate the machine while under the influence of alcohol or drugs, or while fatigued.
- When working in cooperation with others, let them know in advance what you are doing.
- Always sit in the tractor seat when starting the engine or operating controls. Do not start the engine or operate controls while standing beside the tractor.

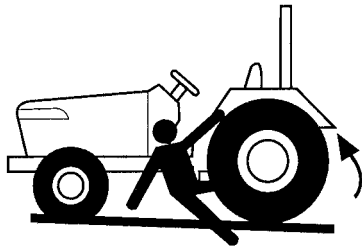

- Before starting the engine, sit in the seat, disengage the clutch, and place the shift levers in the neutral position.
- Use the ROPS (Roll Over Protective Structure) and seat belt for safe operation. Overturning the tractor without a ROPS, or with a ROPS and the seat belt unfastened, can result in injury or death.

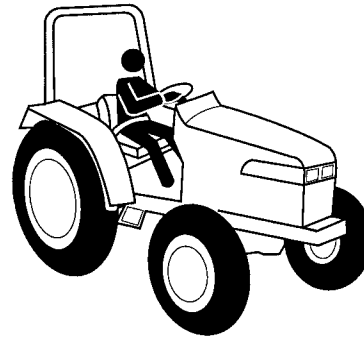

- Do not allow anyone but the operator to ride on the tractor unless a passenger seat is fitted. Keep bystanders away from the tractor during operation.

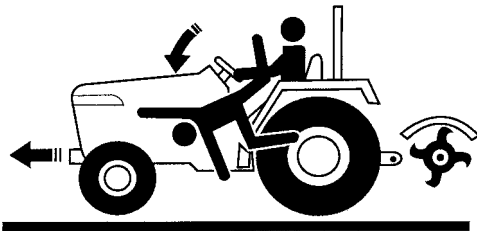

- Always use the seat belt when the tractor is equipped with a ROPS. Never use the seat belt when the tractor is not equipped with a ROPS.
- Whenever possible, adjust the rear wheels to their maximum tread width to improve stability of the tractor during operation.
- Engage the parking brake, place the position control lever in the down position, and place the transmission levers in neutral before starting the tractor.
- Avoid accidental contact with control pedals while the engine is running, as this can cause unexpected movement of the tractor.

- Never leave a running machine unattended. Always engage the parking brake, lower implements to the ground, stop the engine and remove the key before dismounting.
- Do not modify or alter, or permit anyone else to modify or alter, any tractor components or any tractor functions.

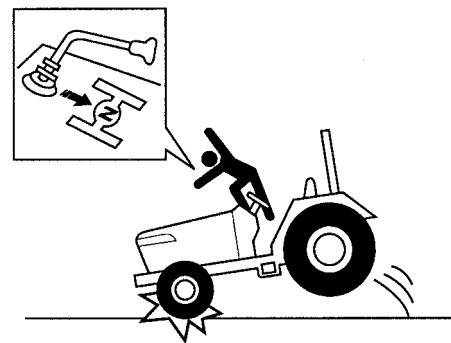
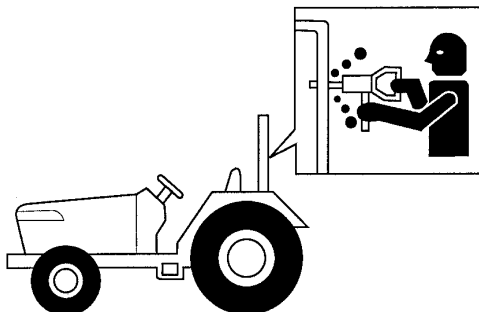

- Shut off the engine and PTO, and engage the parking brake before getting off the tractor.

- Never try to get on or off a moving tractor.
- Never park the tractor on a steep incline.

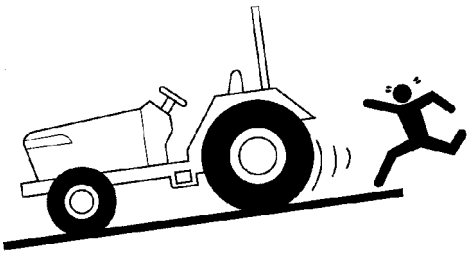

- Do not run the engine in an enclosed building without adequate ventilation. Exhaust fumes can cause death.

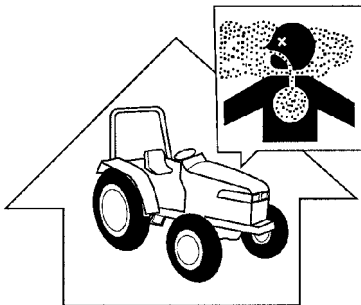

- Pull only from the drawbar. Make certain the drawbar pin is locked in place. Pulling from the rear axle of the tractor or any point above the axle could cause the tractor to overturn.
- Maintain the weight balance of the tractor. Install front end weights to counterbalance heavy implements attached to the three point hitch. Do not operate the tractor with a light front end.

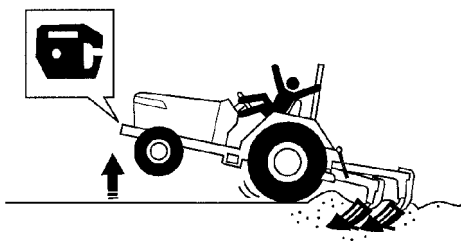

- Check all connections, and tighten if necessary, before starting the engine or pressurizing lines.
- Do not leave equipment in the raised position when the vehicle is stopped or unattended.
- Use only accessories approved for this machine by the manufacturer. Read, understand and follow all instructions provided with the approved accessory. Know your equipment and its limitations.

- Use the 3-point hitch only with equipment designed for 3-point hitch usage.
- Do not operate near embankments, ditches, holes, or other terrain features which may collapse under the tractor's weight. The tractor could suddenly turn over if a wheel goes over the edge of a cliff or ditch, or if an edge caves in.
- Driving forward out of a ditch or mired condition, or up a steep slope, increases the risk of the tractor flipping over backward. Use reverse to free the tractor in these situations.
- Check overhead clearance carefully before driving under power lines, wires, bridges or low hanging tree branches, before entering or leaving buildings, or in any other situation where the operator and/or roll bar may be struck, which could result in serious injury.



- Remember that your tractor, if abused or incorrectly used, can be dangerous and become a hazard both to the operator and to bystanders. Do not overload, or operate with attached equipment which is unsafe, not designed for the particular task, or is poorly maintained.
- Lock the brake pedals together when traveling at road speeds. Brake both wheels simultaneously when making an emergency stop. Uneven braking at road speeds could cause the tractor to tip over.
- Watch for traffic when operating near or crossing roadways. If local laws permit road travel, use the headlights, flashing hazard lights and SMV signs when traveling on public roadways.
- Do not engage the differential lock while traveling at road speeds. Difficulty steering could cause you to lose control of the tractor.
- Avoid sudden motions of the steering wheel as they can lead to a dangerous loss of stability. The risk is especially great when the tractor is traveling at road speeds.

- Always slow the tractor down before turning. Turning at high speed may tip the tractor over.



- To avoid upsets, drive the tractor with care and at a safe speed. Use extra caution when operating over rough ground, when crossing ditches or slopes, and when turning corners.
- Wear sturdy work shoes. Never operate the tractor in bare feet, sandals, or sneakers.
- Do not wear loose fitting clothes or jewelry. They can be caught in moving parts.
- When towing equipment, use safety chains and place an SMV emblem on the equipment.
- Any towed vehicle with a total weight exceeding that of the tractor should be equipped with its own braking system that is operational from the tractor seat.

2. SLOPE OPERATION

Slopes are a major factor related to loss of control and tip-over accidents which can result in severe injury or death. All slopes require extra caution. If you cannot back up the slope or if you feel uneasy on it, do not operate this unit on that area or serious injury could result.

DO:

- Operate up and down slopes, not across.
- Remove obstacles such as rocks, limbs, etc.
- Watch for holes, ruts or bumps. Uneven terrain could overturn the machine. Tall grass can hide such obstacles.
- Place the transmission in the low range. when climbing or descending slopes. Always keep machine in gear when going down slopes to take advantage of engine braking action.
- Follow the manufacturers recommendations for counterweights to improve stability.

- Keep all movement on the slopes slow and gradual. Do not make sudden changes in speed or direction. Rapid engagement or braking could cause the front of the machine to lift and rapidly flip over backwards which could cause serious injury.

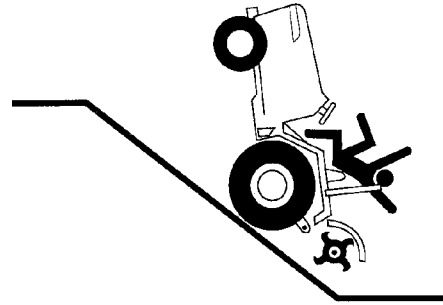

- Avoid starting or stopping on a slope. If tires lose traction, disengage the PTO and proceed slowly straight down the slope.

DO NOT:

- Do not turn on slopes unless necessary; then, turn slowly and gradually downhill, if possible.
- Never "free-wheel". Disengaging the clutch or shifting into neutral while descending a slope could lead to a loss of control.

3. CHILDREN

- Tragic accidents can occur if the operator is not alert to the presence of children. Children are often attracted to the machine. Never assume children will remain where you last saw them.
- Keep children out of the operating area and in watchful care of an adult other than the operator.
- Be alert and turn machine off if children enter the area.
- Before and when backing, look behind and down for small children.
- Never carry children. They may fall off and be seriously injured or interfere with safe machine operation.
- Never allow children to operate the machine.
- Use extra care when approaching blind corners, shrubs, trees or other objects that may obscure your vision of a child or other hazard.
- Remove key when machine is unattended to prevent unauthorized operation.

4. OPERATING THE PTO

- Disengage the PTO, stop the engine, and wait until all moving components have completely stopped before dismounting the tractor and connecting, disconnecting, adjusting, cleaning, or servicing any PTO driven equipment.
- Do not wear loose fitting clothing when operating the PTO or when near rotating equipment.
- Keep the PTO shaft cover in place at all times. Replace the PTO shaft cap when the shaft is not in use.
- When operating stationary PTO driven equipment, always apply the tractor parking brake and place chocks behind and in front of the rear wheels. Stay clear of all rotating parts.

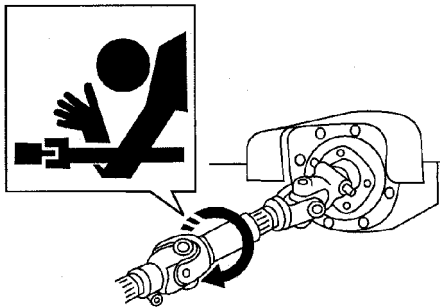

- Replace fuel cap securely and wipe off any spilled fuel before starting the engine as it may cause a fire or explosion.
- Do not smoke when working around the battery or when refueling. Keep all sparks and flames away from the battery and fuel tank. The battery presents an explosive hazard because it gives off hydrogen and oxygen... especially when recharging.



- Never store the fuel container or machine inside where there is an open flame or spark, such as a gas hot water heater, space heater or furnace.
- The cooling system is under pressure. Never remove the radiator cap when the system is hot. Slowly turn the cap the to the first stop to release pressure before removing the cap. If the tractor has a coolant recovery tank, add coolant there instead of to the radiator.

5. SAFETY FRAME (ROPS)

Your tractor is equipped with a rollover protective structure (ROPS) which must be maintained in a fully functional condition. Use care when driving through doorways or spaces with a low overhead.

- Never modify the ROPS in any way.
- Never attempt to straighten or reweld any part of the main frame or retaining brackets that have been damaged. Doing so may weaken the structure and endanger your safety.
- Never secure any parts on the main frame or attach the safety frame with anything other than the special fasteners specified.
- Never attach ropes, chains, or cables to the ROPS for pulling purposes.
- Although the ROPS provides you the maximum protection possible, never take unnecessary risks.

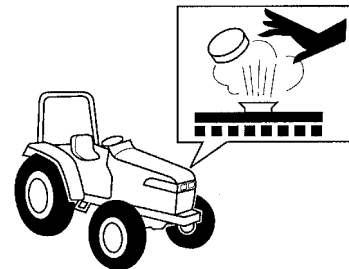

- Escaping hydraulic fluid under pressure can penetrate the skin. If fluid is injected into the skin, seek immediate medical attention. Do not use your hand to check for leaks. Use a piece of cardboard or paper.

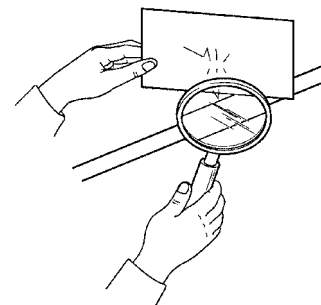

6. SERVICE

- Use extreme care in handling fuels. They are extremely flammable and the vapors are explosive. Use only an approved container.
- Never remove fuel cap or add fuel with the engine running.

- Engine components become hot during operation and can cause a burn. Allow to cool down before touching.
- Before "jump starting" a dead battery, read and follow all of the instructions.
- Do not attempt to mount a tire on the rim. This should be done by a qualified person with proper equipment.
- Always maintain the correct tire pressure. Do not inflate tires above the recommended pressure shown in the operator's manual.

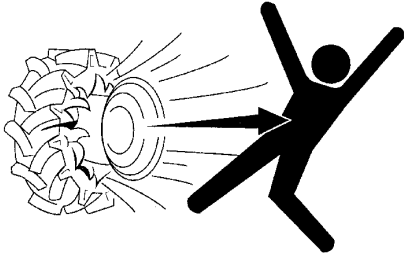

- Securely support the tractor when changing wheels or the wheel tread width.
- Make sure that wheel bolts have been tightened to the specified torque.
- To avoid sparks from arcing, always disconnect the battery's negative cable first and connect it last.

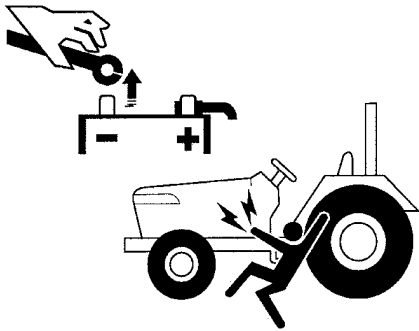

- Disconnect negative cable from battery before working on or near electrical components.
- To reduce fire hazard, keep the tractor free of any debris build-up. Clean up oil or fuel spillage.
- Before cleaning, repairing or inspecting, make certain all moving parts have stopped. Keep all nuts, bolts and screws tight to be sure the equipment is in safe working condition.
- Never tamper with safety devices. Check their proper operation regularly.
- Check brake operation frequently. Adjust and service as required.
- Observe proper disposal laws and regulations. Improper disposal of fluids and materials can harm the environment and the ecology.
- Prior to disposal, determine the proper method to dispose of waste from your local Environmental Protection Agency. Recycling centers are established to properly dispose of materials in an environmentally safe fashion.
- Use proper containers when draining fluids. Do not use food or beverage containers that may mislead someone into drinking from them. Properly dispose of the containers immediately following the draining of fluids.
- DO NOT pour oil or other fluids into the ground, down a drain or into a stream, pond, lake or other body of water. Observe Environmental Protection Agency regulations when disposing of oil, fuel, coolant, brake fluid, filters, batteries, tires and other harmful waste.
- We do not recommend the use of a pressure washer or garden hose to clean your unit. They may cause damage to electrical components; spindles; pulleys; bearings; or the engine. The use of water will result in shortened life and reduce serviceability.



WARNING: - YOUR RESPONSIBILITY: Restrict the use of this power machine to persons who read, understand and follow the warnings and instructions in this manual and on the machine.

SAFETY LABELS

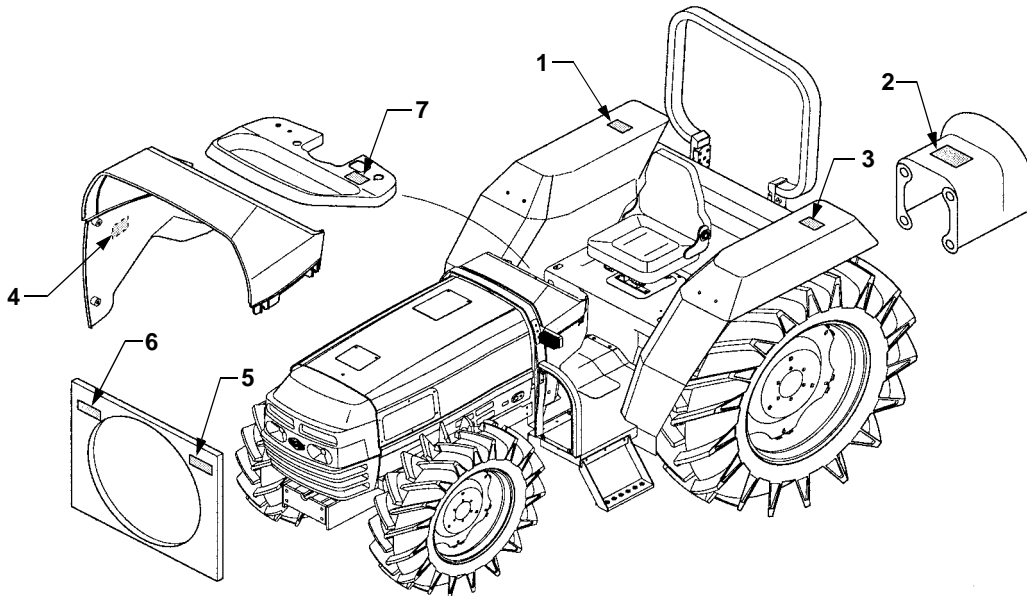

1. DD-T2325-50512

3. DD-T2325-50724

⚠ CAUTION

1. Read and understand the owner's manual before attempting to operate this tractor
2. Start the tractor in neutral and with clutch pedal fully depressed.
3. Start the engine only while in the operator's seat.
4. Keep people far away from tractor when working.
5. Avoid sharp turns or sudden braking.
6. Always slow down when driving on rough ground.
7. Always stop the engine and set the brake before checking, adjusting or repairing the tractor or implement.
8. Always lower implements to the ground before leaving the tractor seat.
9. Only the operator should be allowed on the tractor.
10. Lock brake pedals together, use warning lights, and use a slow moving vehicle emblem when traveling on the roadway.
11. Failure to follow the instructions above or in the owner's manual can cause serious injury to the operator or other persons.

⚠ WARNING ⚠

TO AVOID PERSONAL INJURY:

1. Roll-Over Protective Structure (ROPS) with a seat belt is recommended in most applications. Check the OWNER's manual and discuss with your local dealer.
2. Always use the seat belt when the tractor is equipped with ROPS. Never use the seat belt when the tractor is not equipped with ROPS.

4. DD-T2241-50702

2. DD-T2325-50743

⚠ WARNING ⚠

TO AVOID INJURY FROM PTO:

1. Keep all shields in place.
2. Keep hands, feet and clothing away.
3. Disengage PTO, stop the engine and set the brake before adjusting, repairing or servicing the tractor or implement.

TO AVOID PERSONAL INJURY:

1. Attached pulled or towed loads to the drawbar only.
2. Use the 3-point hitch only with equipment designed for 3-point hitch usage.

⚠ WARNING

TO AVOID POSSIBLE INJURY OR DEATH

1. Do not start engine by shorting across starter terminals. Machine may start in gear and move if normal starting circuitry is bypassed.
2. Start engine only from operator's seat with transmission and PTO in neutral. Never start engine while standing on ground.

SAFETY LABELS (Cont.)

5. DD-T4625-52361

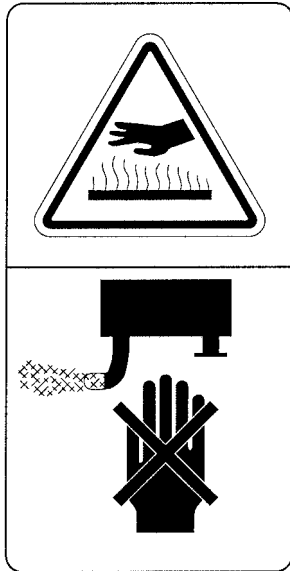

7. DD-T4625-53191

⚠ WARNING

1. Before leaving the tractor, park the tractor on level ground, apply the parking brake, disengage the P.T.O. and stop the engine.

2. Avoid accidental contact with the gear shift levers while the engine is running as unexpected tractor movement can result.

6. DD-T4625-52351



SECTION 1: CONTROLS AND FEATURES

SWITCHES AND DASH MOUNTED CONTROLS

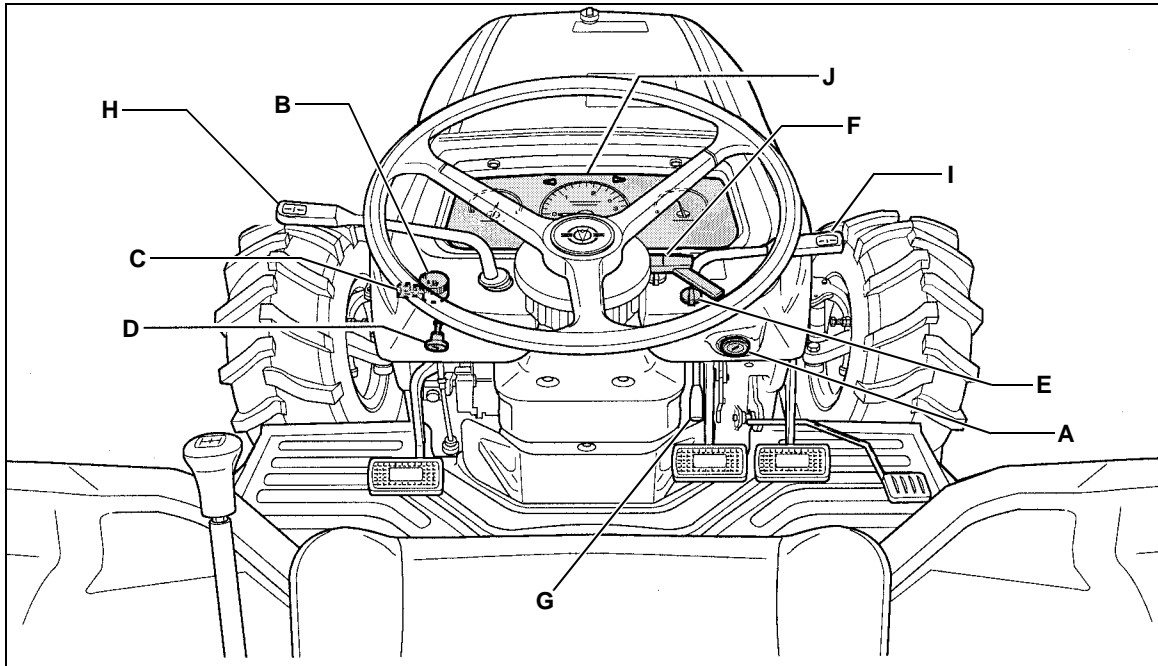

Figure 1

- | | |
|-----------------------|--------------------------------|
| A. Ignition Switch | F. Steering Tilt Lock Lever |
| B. Light Switch | G. Parking Brake Lever |
| C. Turn Signal Switch | H. Forward/Reverse Shift Lever |
| D. Hazard Lamp Switch | I. Hand Throttle Lever |
| E. PTO Switch | J. Instrument Panel |

A. Ignition Switch

NOTE: To prevent accidental starting and/or battery discharge, remove the key from the ignition switch when the tractor is not in use.

The ignition switch has four positions turning clockwise as follows (Refer to Figure 2):

OFF - The engine and electrical system is turned off.

ACC - Energizes the accessory circuit.

ON/HEAT - Energizes the tractor's electrical system. Warning lamps on the instrument panel are momentarily illuminating to test the system. Engine glowplugs are also energized to preheat the combustion chamber.

START - Activates the starter motor to turn over and start the engine. When the engine starts release the key immediately and it will return to the ON position.

NOTE: The safety circuit will prevent the starter from turning if the clutch pedal is not depressed.

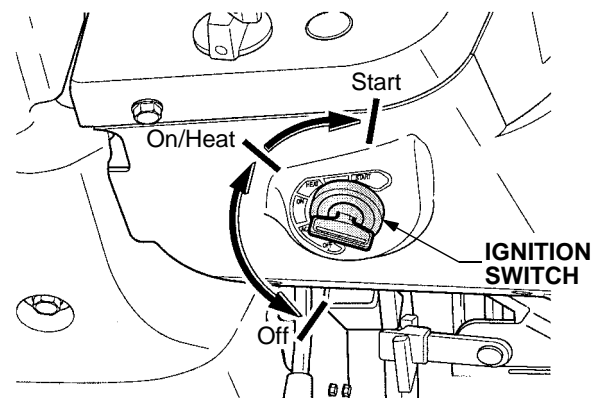

Figure 2

B. Light Switch

Turn the light switch one click clockwise to illuminate the low beam headlights and the taillights.

Turn the light switch one more click clockwise to illuminate the high beam headlights. See Figure 3.

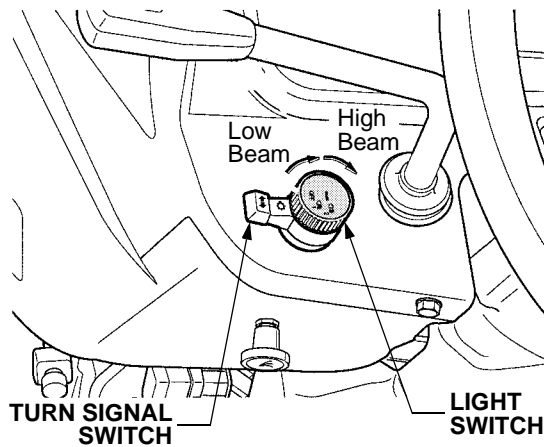

Figure 3

C. Turn Signal Switch

Use the switch lever to activate one of the rear amber lights and hazard lights in a blinking mode to indicate a turn in that direction. Refer to Figure 3.

Lever downward — Left light flashes
Lever upward — Right light flashes

D. Hazard Lamp Switch

Use to turn on the two amber hazard lights located on top of the rear fender in the flashing mode. Refer to Figure 4.

- Pull the switch outward to activate amber lights.
- Push in to turn off.

E. PTO Switch

Use this switch to engage and disengage the 540 RPM rear PTO shaft. See Figure 4.

The PTO switch has three positions as follows:

OFF Position — Center position of switch. Stops the rotation of the rear PTO shaft.

NOTE: The PTO switch must be placed in the OFF position before starting the engine. The engine starter motor will not engage if the PTO switch is not in the OFF position.

AUTOMATIC Position — Turn top of switch to left. The PTO will operate only when the 3-point hitch and its mounted implement are lowered using the position control lever.

MANUAL Position — Turn top of switch to right. The PTO will operate continuously until the switch is returned to the OFF position.

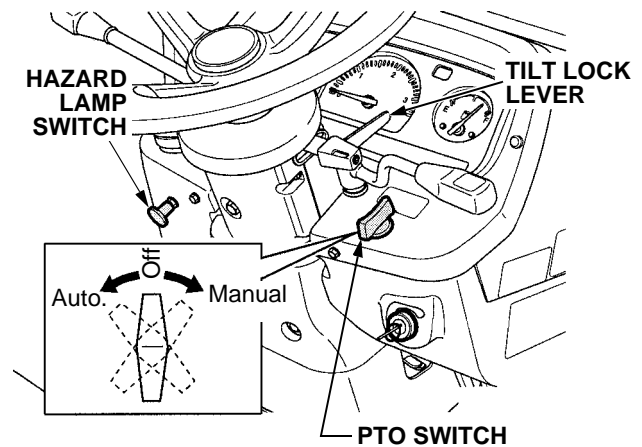

Figure 4

F. Steering Tilt Lock Lever

Use this lever to lock the steering wheel in the tilt position selected by the operator. See Figure 4.

To reposition the steering wheel proceed as follows:

- Grasp the handle of the lever and push inward.
- Rotate the lever counterclockwise to loosen.
- Adjust the position of the steering wheel.
- Push the handle inward and rotate clockwise until tight to lock the steering wheel.
- Pull the handle outward.



WARNING: Make sure the steering wheel is locked before driving the tractor. Never adjust the steering wheel while in motion.

G. Parking Brake Lever

Use this lever, located below the dash panel to the right of the steering column, to set the parking brake before dismounting the tractor. See Figure 5.

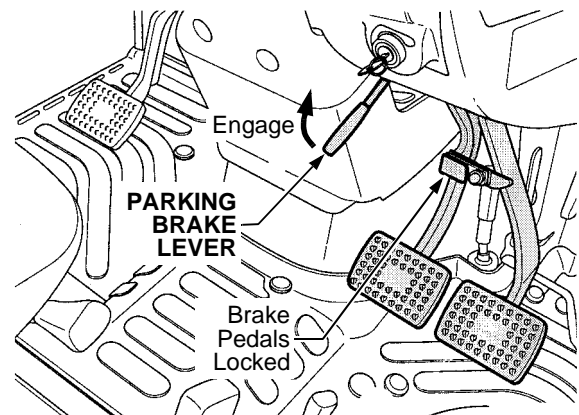

Figure 5

To set the parking brake proceed as follows:

- Lock the right and left brake pedals together using the brake lock. Refer to **Brake Lock in Floorboard and Fender Mounted Controls** later in this section.
- Fully depress and hold the brake pedals.
- Pull the brake lock lever upward and hold while releasing the brake pedals. If properly engaged, both the lever and the brake pedals will lock in their present position.
- Depress the brake pedals again to release the parking brake.

H. Forward/Reverse Shift Lever

Use this lever to set the tractor's direction of travel.



WARNING: Never shift the forward/reverse lever without first disengaging the tractor's clutch by depressing the clutch pedal. Failure to do so will result in severe damage to the transmission.

To change the direction of travel, proceed as follows:

- Fully depress the clutch pedal.
- Shift the lever into one of three positions (See Figure 6).

Forward position — The tractor will drive in the forward direction.

Center position — Tractor in neutral.

Rearward position — The tractor will drive in the reverse direction.

- Slowly and evenly release the clutch pedal.

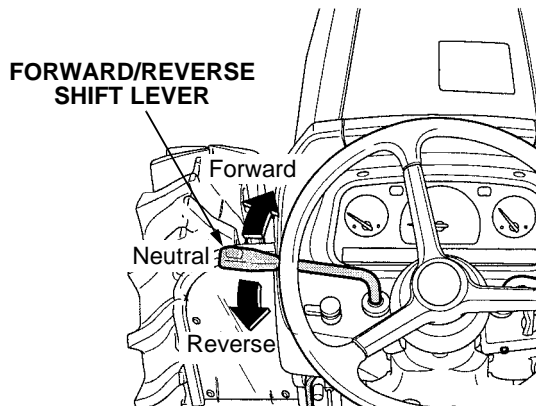

Figure 6

I. Hand Throttle Lever

When the hand throttle is pushed forward, the engine speed will increase. When pulled rearward, the engine speed will decrease.

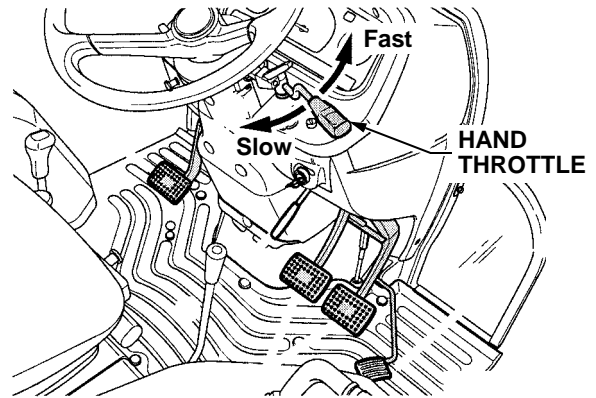

Figure 7

J. Instrument Panel

The instrument panel contains the following gauges and indicator lights to inform the operator of tractor conditions (See Figure 8):

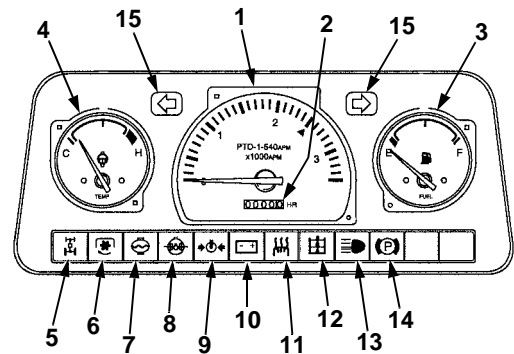

Figure 8

1. Tachometer - Indicates the engine speed in revolutions per minute (RPM). When operating PTO driven equipment, adjust the engine speed so that the tachometer needle is at the 540 PTO rpm mark, unless otherwise specified in the equipment owner's manual. See Figure 9.

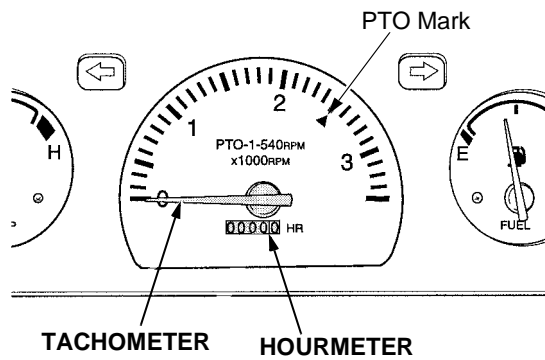

Figure 9

2. Hour meter (In Tachometer) - This meter shows the number of hours the tractor has been operated at rated engine RPM. The right-most digit (white background) indicates tenths of an hour. Monitor the hour meter to ensure all maintenance procedures are completed according to the maintenance schedule. Refer to Figure 9.
3. Coolant Temperature Gauge - Indicates the temperature of the engine coolant. Monitor the gauge to allow the engine to warm up when first starting the tractor. Do not operate the tractor under load before the temperature gauge indicates the proper temperature. Monitor the gauge to protect against overheating the engine (the red section on the temperature gauge indicates overheating). See Figure 10.

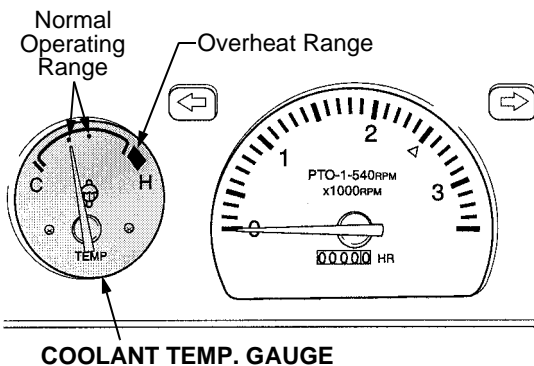

Figure 10

4. Fuel Gauge - Indicates the volume of fuel in the fuel tank.
5. 4WD Indicator - Illuminates when the front drive lever has been engaged.
6. PTO Indicator - Illuminates when the PTO is engaged.
7. Coolant Level Lamp - Illuminates if the engine coolant level falls below a prescribed level. Stop the tractor and refill the cooling system.
8. Differential Lock Indicator - Illuminates when the differential lock pedal has been engaged.
9. Engine Oil Pressure Warning Lamp - Illuminates when the ignition switch is turned on to assure the light is functioning properly. The light should go off after the engine starts. If the light remains on, stop the engine immediately and inspect for the cause or contact your Cub Cadet dealer.
10. Battery Charge Warning Lamp - Illuminates when the ignition switch is turned on and should go off as the engine starts. If the lamp continues to glow above idle speeds, indicating the battery is being discharged, stop the tractor and have the electrical system checked for the cause.
11. Glow Plug Indicator - Lights for approximately 10 seconds after the glow plugs are energized, then turns off to indicate the combustion chambers are preheated. **NOTE:** Although the lamp turns off, it normally takes approximately 20 seconds for the glow plugs to fully heat a cold engine. The lower the ambient temperatures, the longer the pre-heating time needed.
12. Hydraulic Filter Warning Lamp - Illumination indicates a problem with hydraulic oil flow through the filter.
13. High Beam Lamp - Illuminates when the headlight switch is turned to high beam position.
14. Parking Brake Indicator - Illuminates when the parking brake is engaged.
15. Turn Signal Indicators - One of the lamps light in a flashing mode to indicate that turn signal has been activated with the turn signal switch.

FLOOR BOARD AND FENDER MOUNTED CONTROLS

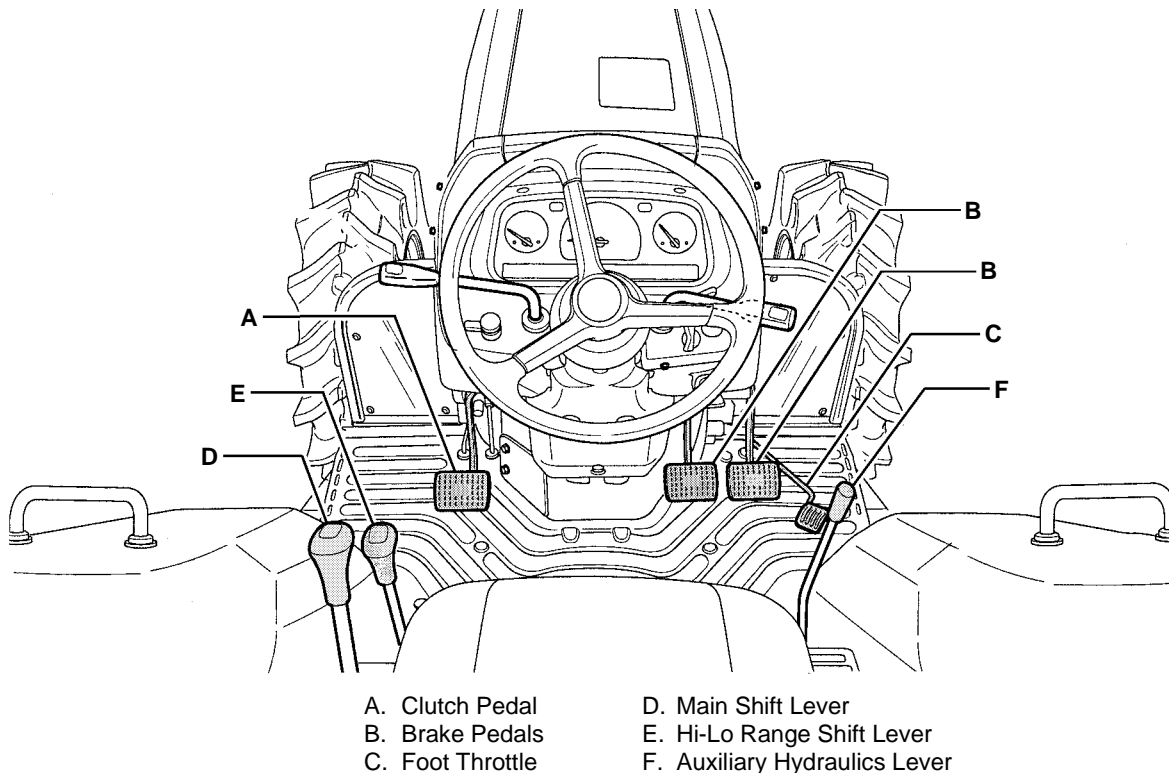

Figure 11

A. Clutch Pedal

When the clutch pedal is fully depressed, the tractor's drive clutch is disengaged. Fully and rapidly depress the clutch pedal before shifting the main shift lever, the Hi-Lo Range lever, or the forward/reverse shift lever. Gradually release the clutch pedal after shifting.

IMPORTANT: *The clutch pedal should be rapidly depressed, but slowly and evenly released to prevent damage to the clutch plates. Never operate the tractor with your foot resting on the clutch pedal. Doing so may contribute to premature clutch wear.*

B. Brake Pedals (Right and Left)

- The right (outer) brake pedal engages only the right brake assembly. Refer to Figure 12.
- The left (inner) brake pedal engages only the left brake assembly. Refer to Figure 12.

Use the individual brake pedals to assist in making sharp turns while operating the tractor in the field. Depress the brake pedal corresponding to the direction of the turn.



WARNING: Always lock the brake pedals together before driving the tractor on roadways or at high transport speeds. Engaging only one brake under these operating conditions could cause a dangerous accident.

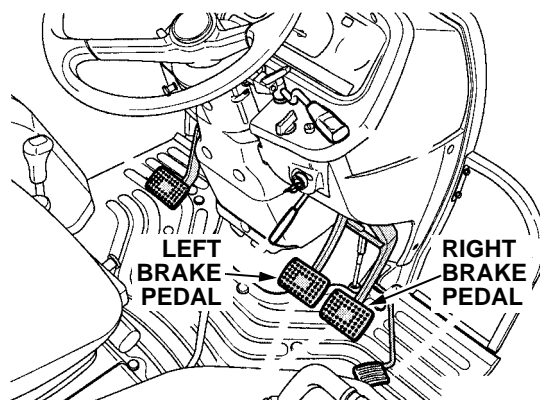

Figure 12

C. Foot Throttle

The foot throttle is interlocked with the hand throttle. Depressing the foot throttle increases the engine speed. Full engine speed control can be obtained with the foot throttle if the hand throttle is in the full rearward (slow) position. The foot throttle may also be used to temporarily increase the engine speed above the hand throttle setting.

D. Main Shift Lever



WARNING: Never shift the main shift lever without first disengaging the tractor's clutch by depressing the clutch pedal. Failure to do so will result in severe damage to the transmission.

The main shift lever allows you to shift the tractor's transmission into any of four gear sets. Each gear set represents a change in tractor speed, with 1 being the slowest speed and 4 the fastest. The synchromesh type gearbox allows you to change gears without stopping by just fully depressing the clutch pedal. The shift pattern is in the form of an "H" with the center position being neutral. See Figure 13.

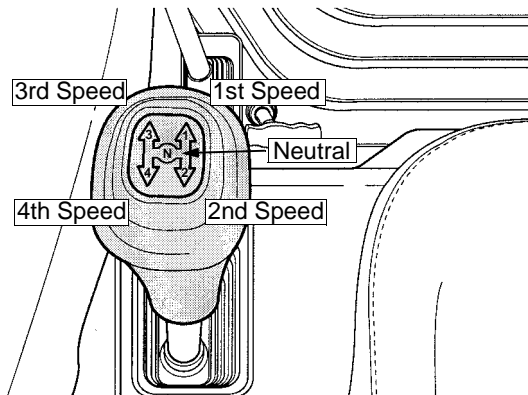

Figure 13

E. Hi-Lo Range Shift Lever



WARNING: Never shift the Hi-Lo range shift lever without first disengaging the tractor's clutch by depressing the clutch pedal. Failure to do so will result in severe damage to the transmission.

The Hi-Lo range shift lever allows you to shift the tractor's transmission into any of three speed ranges (See Figure 14).

To shift into the High, Middle, or Low range, completely stop the tractor and fully depress the clutch pedal.

- Move the lever to the left and forward to shift into the High (faster) range.
- Move the lever to the left and rearward to shift into the Middle (medium) range.
- Move the lever to the right and rearward to shift into the Low (slower) range.
- Move the lever to the center position to place in neutral.

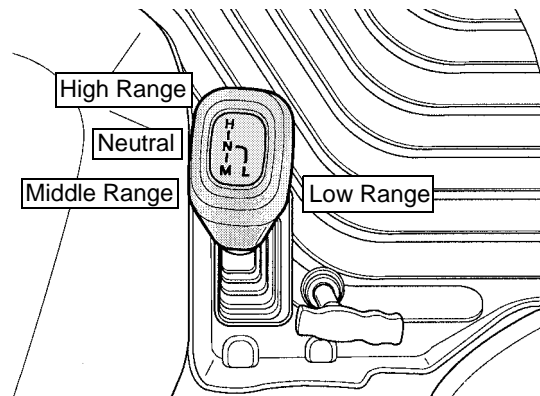

Figure 14

Use in combination with the main shift lever and the forward/reverse lever to obtain twelve speeds in forward and twelve speeds in reverse

F. Auxiliary Hydraulics Lever

Use this lever to control the cylinder positions of optional implements attached to the remote hydraulic outlets of the tractor.

IMPORTANT: Do not hold the lever in the "Pull" or "Push" position once the remote cylinder has reached the end of its stroke. Doing so will force oil through the relief valve, and over a prolonged period cause the hydraulic oil to overheat.

Front Wheel Drive Lever

The front wheel drive lever is located in the floorboard, below and to the left of the seat.

Use the front wheel mechanism only when additional traction is needed to drive the tractor. For example: when operating ground engaging equipment such as a front end loader; when climbing slopes; or when operating in wet, sandy or loose soil conditions.

- To engage the front wheel drive mechanism, depress the clutch pedal and push the front wheel drive lever downward. See Figure 15.
- To disengage the front wheel drive, depress the clutch pedal and pull the lever upward.

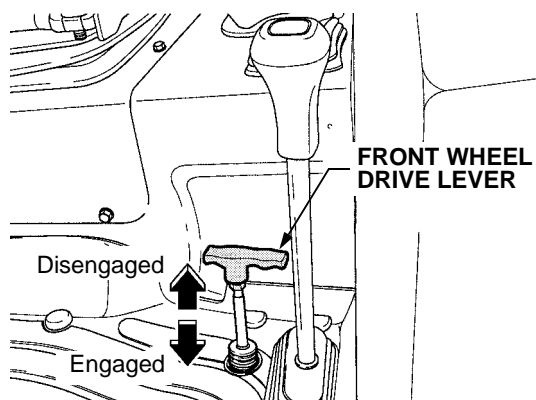

Figure 15

Differential Lock Pedal

Located at the rear of the right floor board, the differential lock is used to gain additional traction when operating the tractor on wet or loose soil. When the pedal is depressed the rear wheels of the tractor are prevented from rotating independently of one another. See Figure 16.

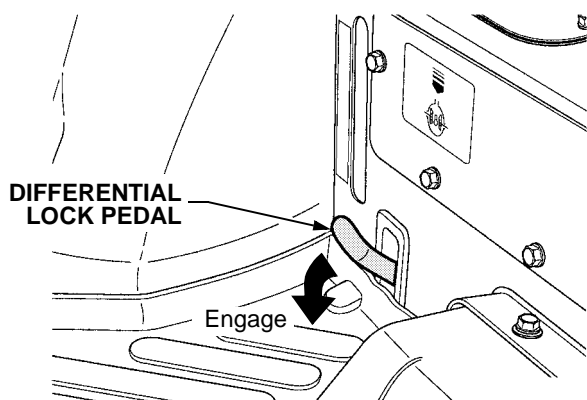

Figure 16



WARNING: When operating with the differential lock engaged, the tractor will be difficult to steer. To prevent loss of control of the tractor, do not drive the tractor on roadways or at speeds above 5 MPH with the differential lock engaged.

- To engage the differential lock, lightly step on the differential lock pedal with your heel.
- To disengage, simply release the pedal.

Hydraulic Control Levers

The hydraulic control levers, consisting of the position control and draft control levers, are located on the right fender. See Figure 17.

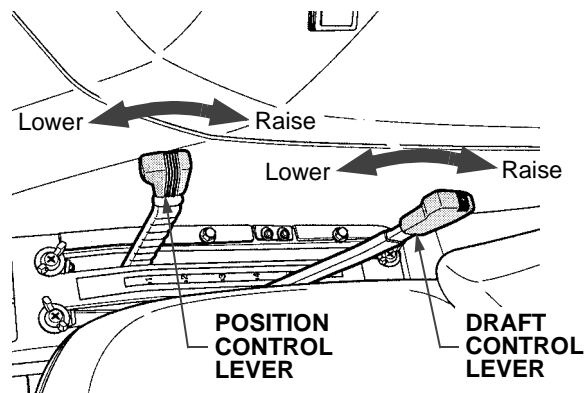

Figure 17

Use these control levers to control the working depth and pull of implements attached to the three point hitch as follows:

- Using Position Control — This will control the working depth of 3-point implements regardless of the amount of pull required. Push the draft control lever forward to the lowest position and set the implement working depth by moving the position control lever to the desired position.
- Using Draft Control — This will control the pull of the 3-point implement. As the pull on the 3-point hitch changes due to various soil conditions, the draft control system automatically responds to these changes by either raising or lowering the implement slightly to maintain a constant pull. Push the position control lever forward to the lowest position and set the implement pull by moving the draft control lever to the desired setting.

- Using Mixed Control — In draft control, when draft decreases, the implement automatically lowers to increase draft. However, the implement sometimes lowers too much. To limit the degree the implement can be lowered, set the position control lever at the lowest working depth desired for the implement; then lower the draft control lever to the point where the implement is at the desired depth. This stops the implement from going too deep and also controls the pull to prevent loss of traction and ground speed.

Brake Pedal Lock

The brake pedal lock is located on the right brake pedal. Flip the lock counterclockwise so it engages the bracket on the left brake pedal to interlock both brake pedals. See Figure 18.

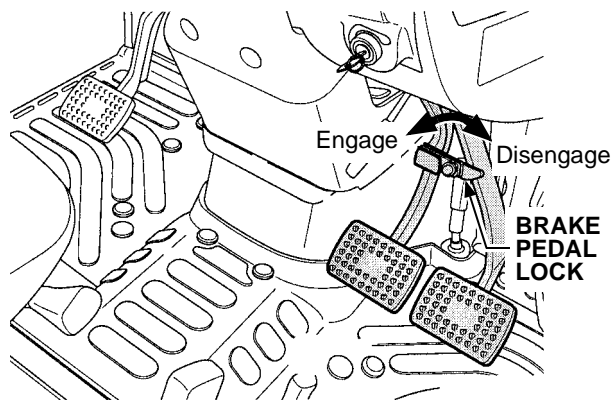

Figure 18

Seat Adjustment Lever

The seat adjustment lever is located beneath the left side of the seat. This lever is used to adjust the seat forward or backward to the desired operating position. See Figure 19.

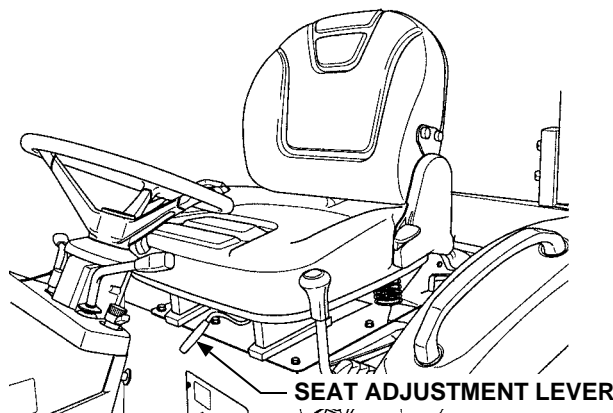



Figure 19

PTO Safety Switch

Located on the right fender. To stop the PTO in an emergency, depress the switch. The switch must be pressed a second time (switch button in the up position) to re-engage the PTO. See Figure 20.

-   - On
-   - Off

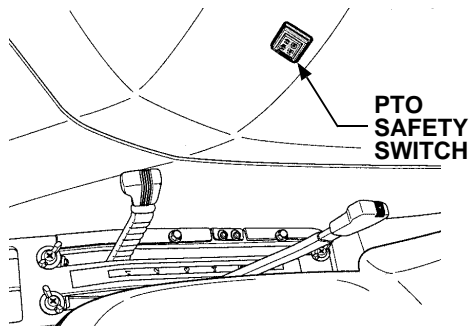

Figure 20

SECTION 2: OPERATION

ROLLOVER PROTECTIVE STRUCTURE (ROPS)

This tractor is equipped with a foldable Rollover Protection Structure (ROPS) and seat belts. When used together they are effective in reducing injuries to the operator in the event of an accidental tractor rollover. The safety provided by the ROPS is minimized if the seat belt is not properly adjusted AND buckled.



WARNING: Always wear the seat belt when operating the tractor equipped with a ROPS. However, if the ROPS is in the folded position or has been re-moved, the seat belt must not be used.

Use the following guidelines when using a tractor equipped with a ROPS:

- Be aware of overhead clearances in the area of operation. Check for clearance of door (or gate) openings and other overhead objects such as utility lines and tree branches. Overhead objects could catch the ROPS and upset the tractor.
- Do not modify the ROPS by drilling holes for, or welding accessories to the structure.
- Do not use the ROPS to pull objects with the tractor. Use ONLY the tractor drawbar for pulling.
- In the event of an accident, have the ROPS carefully inspected and, if necessary, replaced by your *Cub Cadet* dealer. Do not attempt to repair the ROPS.

PRE-STARTING CHECKS

Perform the following checks every day before starting and operating the tractor.

- Check the air pressures and general condition of the tires.
- Check under the tractor for any indications of oil or water leakage.
- Check that all lamps and lights work properly.
- Walk around the tractor and inspect for loose fasteners.
- Check the transmission oil level.
- Check the engine oil level.
- Check the engine coolant level.
- Check that the air cleaner is free of obstructions and excessive dirt.
- Check the fuel supply.
- Check operation of the clutch and brake pedals.
- Check operation of the parking brake.

FUELING THE TRACTOR

Fill the fuel tank with only clean, fresh, diesel fuel. To ensure the freshness of the fuel, purchase fuel in a quantity that can be used within 30 days.

NOTE: DO NOT USE KEROSENE OR GASOLINE in your diesel engine. Damage to the engine will occur.

Generally a good grade Number Two Diesel Fuel should be used in your diesel engine. However, in extremely cold temperatures a quality Number One Diesel Fuel, or a blend of Number One and Number Two Diesel fuels should be used. In most areas, diesel fuel is properly blended for seasonal use as ambient temperatures change. Therefore, it is important to monitor fuel purchases so that seasonal grade fuels are not carried over after the average ambient temperature has changed.



WARNING: Never fill the fuel tank to the top of the filler neck. Expansion could result in overflow through the vents in the cap.

- Do not smoke while refueling the tractor.
- Do not fill the fuel tank when the engine is running or while the engine is hot.
- The fuel fill cap is located beneath the small access door in the rearward end of the hood. Press downward on the rear of the door to open. See Figure 21.

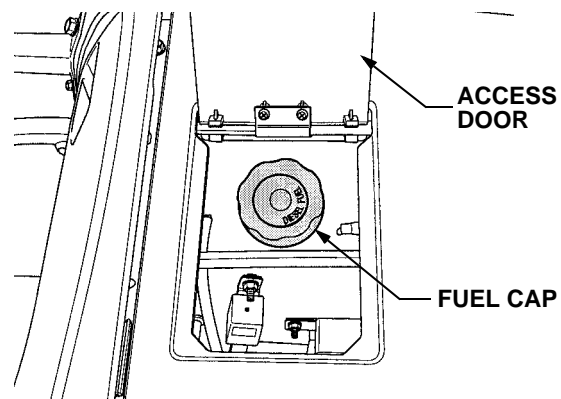

Figure 21

IMPORTANT: Use of a strainer when refueling is recommended to prevent impurities from entering the fuel system and causing contamination of the injection pump.

- Unscrew the fuel cap and fill tank from an approved container. Do not fill the fuel tank to capacity. Allow room for expansion.

- Tighten the fuel cap securely, and immediately wipe up any spilled fuel.
- To minimize condensation, keep the fuel tank as full as possible without filling to capacity. It is a good practice to fill the fuel tank at the end of the day to reduce overnight condensation.
- Do not allow the fuel tank to run dry. Running out of fuel requires bleeding air and priming the fuel system.



WARNING: Fuel in the engine injection system is under high pressure. If not a qualified mechanic, do not attempt to service the fuel injection system. Do not use your hand to check for leaks.

NEW TRACTOR BREAK-IN PROCEDURES

A new tractor is built with high tolerance, well fitted components, but various parts require a break-in period before being subjected to severe work loads. The manner in which the tractor is handled during the "break-in" period greatly affects the life of the tractor. Therefore, to obtain the maximum performance and longest service life from the tractor, it is very important to properly break-in the tractor. Care should be taken during the first 100 hours of operation to operate the tractor at slower speeds and to avoid excessive work loads. In handling a new tractor the following precautions should be observed.

- Do not operate the tractor at full speed for the first 100 hours.
- Do not start quickly or apply the brakes suddenly.
- Never operate a new engine immediately under full load. Allow the engine to warm up.
- Avoid operating the engine for prolonged periods at either high or low speeds with no load.
- Use the transmission's middle (or low) speed range for heavy loads to avoid lugging down the engine due to overload.
- Closely monitor the engine oil and coolant levels, and keep filled to the recommended levels.
- As parts "break-in", minute particles of material may break away, and could cause wear to the component. Therefore, it is very important to perform all break-in maintenance procedures found in the MAINTENANCE section.

STARTING THE ENGINE



WARNING: Always sit in the operator's seat when starting the tractor, Never attempt to start the engine while standing beside the tractor.



WARNING: Never use a starting fluid, such as ether, as a starting aid. Using a starting fluid could cause severe engine damage or a fire, and will void the engine warranty.

- Sit in the operator's seat, adjust the seat position (see ADJUSTMENTS), and fasten the seat belt (only if a ROPS is installed and in the up position).
- Engage the parking brake. See Figure 22.

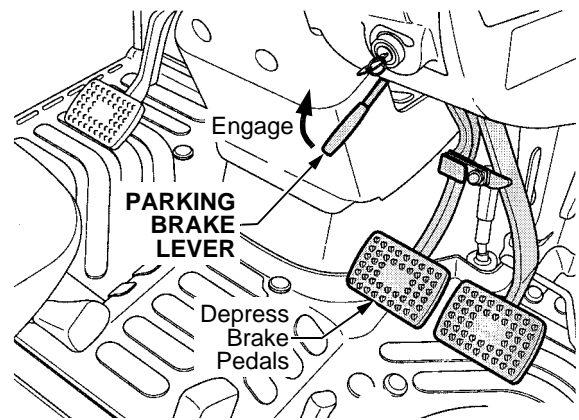

Figure 22

- Place the main gear shift lever, Hi-Lo range shift lever, and the PTO switch in the neutral position.
- Place the position control lever in the lowest position. See Figure 23.

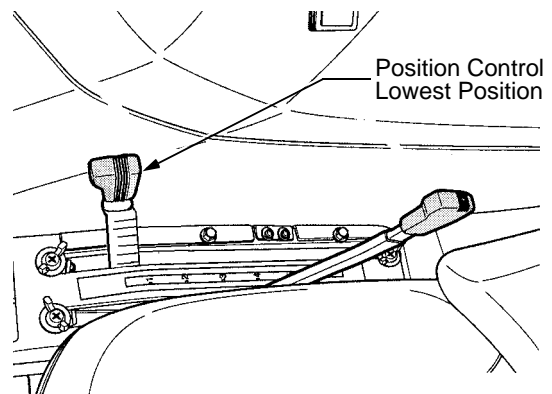

Figure 23

- Set the throttle lever approximately 1/4 of the way forward (approximately 1500 RPM position).

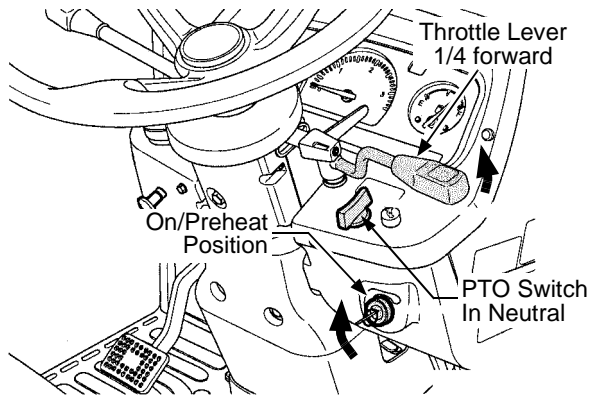

Figure 24

- Turn the ignition switch to the "ON/Preheat" position. Refer to Figure 24.
NOTE: Some of the instrument panel lamps will light momentarily to indicate they are functioning. The oil pressure and battery charge lamps should remain on until the tractor is started.
- Observe the glow plug indicator light on the instrument panel — it should go out after approximately 10 seconds, indicating the combustion chamber has been preheated. However, allowing the glow plugs to preheat an additional 10 seconds (or longer in colder ambient temperatures) is recommended.
NOTE: It is not normally necessary to preheat the engine when restarting after its been warmed up.
- Fully depress the clutch pedal.
- Turn the ignition key to the "START" position and release it as soon as the engine starts; however, do not crank the engine continuously for more than 10 seconds at a time. If the engine does not start within this time, turn the key to "OFF" and wait at least 30 seconds to allow the engine's starter motor to cool. Try again after waiting.
- Slowly release the clutch pedal and allow the engine to run at medium speed for 5 to 10 minutes (depending on ambient temperatures) to warm the tractor before operating under load.

IMPORTANT: The engine oil pressure and battery charge lights should turn off. If they do not, stop the engine immediately and check for the cause or contact your Cub Cadet dealer.

STOPPING THE ENGINE

- Reduce the engine speed to idle using the hand throttle lever and apply even foot pressure on both brake pedals.
- Depress the clutch pedal and place the main shift lever and Hi-Lo range shift lever in neutral.
- Turn the PTO switch to the neutral (OFF) position.
- Use the position control lever to lower equipment.
- Allow the engine to idle for a short period of time.
NOTE: Stopping a hot engine at high speed may cause internal engine damage.
- Interlock the brake pedals using the brake pedal lock and set the parking brake using the parking brake lever.
- Turn the ignition switch counterclockwise to the OFF position to stop the engine.



WARNING: To prevent unauthorized operators from starting the tractor, always remove the key from the ignition switch when leaving the tractor.

DRIVING THE TRACTOR



WARNING: Always allow the engine to warm up before applying load. Avoid sudden starts, excessive speed and sudden stops.



WARNING: Always look behind and down for bystanders or obstacles before operating the tractor in the reverse direction

- If transporting the tractor to a job site or traveling on roadways, make certain the two brake pedals are interlocked. See Figure 25.

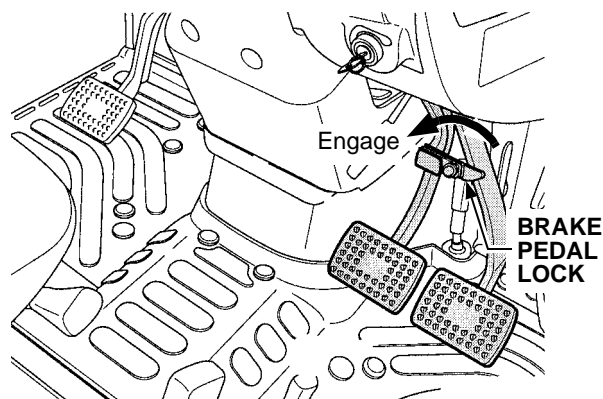

Figure 25

- Fully depress the clutch pedal and proceed as follows:
 - Shift the Forward/Reverse Shift Lever to desired direction. See Figure 26.

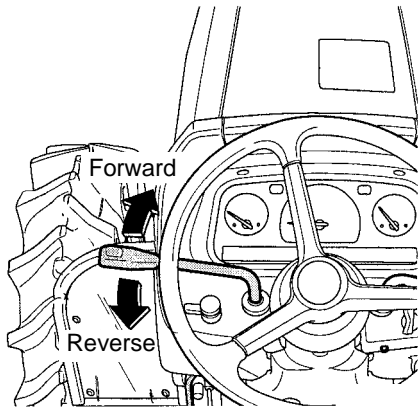

Figure 26

- Shift the Main Shift Lever to desired gear speed. See Figure 27.
- Shift the Hi-Lo Range Shift Lever to desired range. See Figure 27.

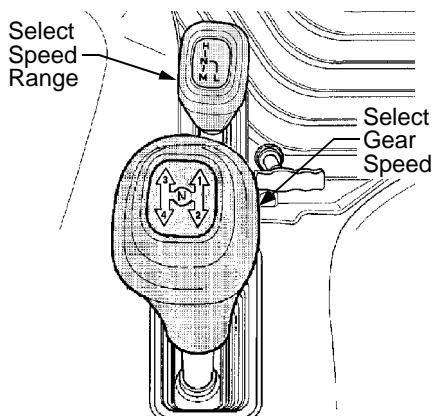

Figure 27

- Pull the position control lever rearward to raise the attachment.
- Momentarily depress the brake pedals to disengage the parking brake. Refer to Figure 28.
- Throttle up the engine to a moderate speed using either the hand throttle or foot throttle. See Figure 28.

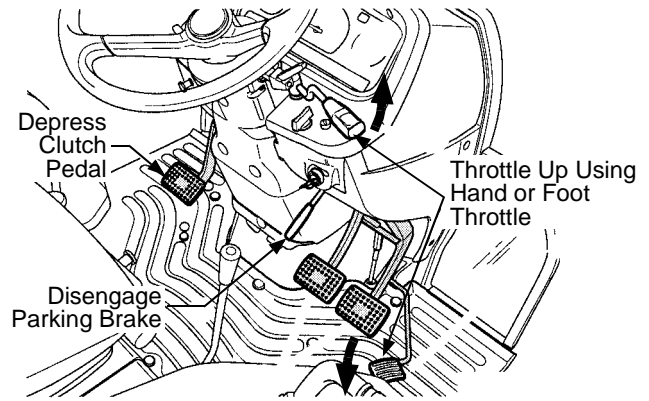

Figure 28

- Slowly release the clutch pedal to start the tractor moving.

NOTE: If operating power driven equipment running off the PTO, the throttle must be increased to the 540 PTO mark unless otherwise specified in the equipment operator's manual. Use the gear shift levers to select a safe travel speed. Proper travel speed will depend on the type of equipment and the condition of the terrain.

IMPORTANT: Do not drive with your foot resting on the clutch pedal. Partial engagement of the clutch will cause clutch slippage and result in premature wear of clutch components.

STOPPING THE TRACTOR

- Reduce the engine speed by pulling the hand throttle rearward and remove your foot from the foot throttle.
- Evenly depress both brake pedals to stop the tractor.
- Depress the clutch pedal and place the main shift lever and Hi-Lo shift lever in neutral.
- Push the position control lever forward to lower equipment to the ground.
- Interlock the brake pedals and fully depress and hold the brake pedals.
- Pull the brake lock lever upward and hold while releasing the brake pedals to engage the parking brake.

- If leaving the tractor, turn the ignition key to the OFF position and remove the key.
- If parking on an incline, chock the wheels to prevent accidental rolling of the tractor.

TURNING THE TRACTOR



WARNING: Turning the tractor while traveling at a fast speed may cause the tractor to overturn.

NOTE: *The tractor is equipped with hydraulic power steering. If front mounted equipment is installed on the tractor and the engine is running at a slow speed, it may take increased steering effort to turn the tractor.*

IMPORTANT: *When the steering wheel is turned completely and held in this position, the hydraulic system may emit a high pitched sound from the relief valve being actuated. Avoid prolonged turns with the tractor's steering wheel held in the completely turned position.*

- Always slow down the tractor by reducing throttle speed and/or downshifting the transmission before turning the tractor.
- Engagement of the differential lock will prevent proper steering and could cause loss of tractor control when turning. Always release the differential lock pedal and make certain it is disengaged before turning the tractor.
- Use the individual wheel brakes to assist turning ONLY when the tractor is working in the field and operating at slower speeds.



WARNING: Sudden application of one brake while traveling at high speed or while making fast turns could cause the tractor to roll over.

DRIVING ON SLOPES



WARNING: When climbing or descending a hill, do not shift the transmission into the neutral position or disengage the clutch.

- Interlock the brake pedals before operating the tractor on a slope. Never use the individual wheel brakes when operating on a slope.
- Operate the tractor up and down slopes, never across slopes. Do not drive so that the tractor may tip over sideways.
- Prior to going uphill, shift the transmission into a low enough gear to allow the tractor to climb the hill without lugging down the engine.

- Prior to going downhill, reduce the engine speed and shift the transmission into a lower gear to take advantage of the braking action of the engine.
- Before operating the tractor on a slope, walk the slope to look for possible hazards such as rocks, mounds, stumps, or surface irregularities which could cause the tractor to be upset.
- Back the tractor with attachment up the steepest portion of each slope you intend to work. If the tractor cannot negotiate the slope in reverse, the slope is too steep to be worked.
- Avoid turns when driving on a slope. If a turn must be made, turn down the slope. Turning up a slope greatly increases the chance of a roll over.
- Avoid stopping when driving up a slope. If it is necessary to stop while driving up a slope, start up smoothly and carefully to reduce the possibility of flipping the tractor over backward.

DRIVING ON ROADWAYS



WARNING: Ensure proper weighting of the tractor, and travel at a safe speed when driving with a rear mounted implement in the raised position. Bouncing of the implement while traveling at higher speeds could momentarily raise the front end of the tractor and result in loss of steering and control of the tractor.

- Make certain the left and right brake pedals are interlocked before driving on public roads.
- Attach an SMV (slow moving vehicle) sign in a visible location on the back of the tractor or rear mounted equipment.
- Reduce the speed of the tractor when turning on sharp curves.
- Downshift the transmission and use the engine to brake when descending steep slopes.
- Use the turn signal to alert other vehicles of your intentions when making turns.
- If driving after dusk or before dawn, turn on all the tractor lights - including the flashing hazard lights. Dim the headlights to oncoming traffic if using the high beams.
- Pay close attention for low shoulders on the side of the road. Dropping the tractor's wheels off the road onto a low shoulder could upset the tractor.
- Obey all traffic laws and allow faster moving vehicles to pass. Do not block the road.

CHECK WHILE OPERATING

While operating the tractor, regularly check the gauges and warning lights on the instrument panel to ensure the tractor is functioning properly.

Coolant Temperature Light

Regularly check that the gauge needle is within the normal operating range. If the needle moves into the red section (overheat) of the gauge, stop the tractor immediately and check for the following causes:



WARNING: After the engine has been running for a short period, the radiator, muffler, engine block, and any metal surface in close proximity to the engine will be HOT. Allow these areas to cool and use extreme caution to avoid burns.



WARNING: Do not remove the radiator cap until the coolant temperature is below its boiling point. Then carefully loosen the cap to its first stop to relieve any pressure before completely removing the cap .

- Check the coolant level. If coolant is low check for possible cause, such as a radiator or hose leak.
- Check for debris on the screen in front of the radiator. Check the passages between the radiator cooling fins for accumulations of dust or dirt.
- Check for a loose fan drive belt.
- Check for internal radiator blockage.

Engine Oil Pressure Lamp

The oil pressure lamp alerts the operator that the engine oil pressure is below the prescribed level. If the lamp should light during operation, stop the engine immediately.

- Check the engine oil level. If the oil level is within the operating range, contact your Cub Cadet dealer.

NOTE: If the engine is left running at idle speed for a prolonged period, the oil pressure lamp may light. This does not indicate a problem with the engine, but this situation should be avoided.

Battery Charge Lamp

The battery charge lamp alerts the operator that the alternator is not charging the battery. If the lamp should light during operation, stop the engine immediately.

- Loose alternator/regulator or wire harness connection.
- Loose alternator drive belt.
- Loose or corroded connections at the battery.

Fuel Gauge

Regularly check the fuel gauge. Do not allow the fuel tank to empty completely. If the tractor runs out of fuel, air is allowed to enter the fuel system, which could cause the engine to run poorly after refueling. If

this happens, the fuel system should be bled prior to restarting the engine (refer to MAINTENANCE).

Observed Problems

The engine should be stopped immediately and the tractor checked if any of the following are observed while operating the tractor.

- The engine suddenly slows down or speeds up.
- Unusual noises are suddenly heard.
- The engine exhaust suddenly and for no apparent reason becomes very dark .

NOTE: The engine exhaust is normally colorless. If the tractor is overloaded the exhaust may become darker until the load is reduced. Try to avoid this situation. Operating the tractor in a prolonged overloaded condition may cause damage to tractor components.

TRAVEL SPEEDS

Using combinations of shift positions for the main shifter, Hi-Lo shifter, and forward/reverse shifter, the tractor can be placed in any of twelve speeds in forward and twelve speeds in reverse.

- Fully depress the clutch pedal before shifting any of the transmission shift levers.
- Do not shift the Hi-Lo range shifter while the tractor is moving. Stop the tractor before shifting.
- At the rated engine speed (approx. 2600 RPM) with standard tires, the approximate speeds are as follows:

Fwd./Rev. Position	Hi-Lo Position	Main Gear Position	Approx. Speed mph (kph)
Forward	Low	1	0.2 (0.4)
		2	0.3 (0.5)
		3	0.5 (0.8)
		4	0.7 (1.2)
	Medium	1	1.1 (1.7)
		2	1.6 (2.5)
		3	2.2 (3.6)
		4	3.6 (5.8)
	High	1	4.6 (7.4)
		2	6.5 (10.5)
		3	9.6 (15.4)
		4	15.3 (24.6)
Reverse	Low	1	0.2 (0.3)
		2	0.2 (0.4)
		3	0.4 (0.6)
		4	0.6 (1.0)
	Medium	1	0.9 (1.4)
		2	1.2 (2.0)
		3	1.9 (3.0)
		4	3.0 (4.8)
	High	1	3.8 (6.1)
		2	5.4 (8.7)
		3	7.9 (12.7)
		4	12.7 (20.4)

USING THE DIFFERENTIAL LOCK

Depressing the differential lock pedal engages a mechanism in the transmission that locks the differential. This prevents the rear wheels from rotating independently of each other and provides constant power to both rear wheels when additional traction is needed.

IMPORTANT: *Do not engage the differential lock when one of the rear wheels is rotating. Stop the wheel rotation and then engage the differential lock.*



WARNING: When operating with the differential lock engaged, the tractor will be difficult to steer. Do not drive the tractor on roadways or at high speeds with the differential lock engaged.

- Using your heel, fully depress and hold the differential lock pedal to engage the transmission differential lock. Release the pedal to disengage the differential lock. See Figure 29.

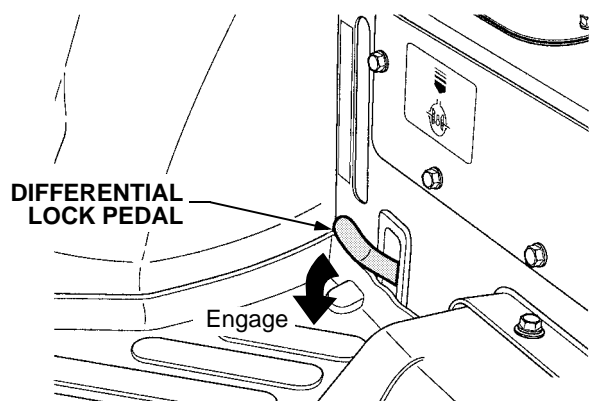

Figure 29

- Apply the differential lock moderately. Limit its use to situations where the tractor is stopped or is unable to drive straight because one of its rear wheels has lost traction due to slippery or loose soil.
- Do not engage the differential lock for prolonged periods. Release the pedal when traction has been restored.

NOTE: *Because of the drive load on the internal engagement mechanism, releasing the pedal may not always disengage the differential lock even though the pedal springs back. It may be necessary to slow the tractor, or engage the brake pedal, to disengage the differential lock.*

USING THE FRONT WHEEL DRIVE

Use the front wheel drive when the conditions require the additional traction provided by all four wheels driving the tractor.

For example:

- When operating ground engaging equipment, such as a front end loader, that may cause the rear wheels to break traction.
- When climbing slopes.
- When operating in wet, sandy or loose soil conditions.

To engage the front wheel drive mechanism, depress the clutch pedal, stop the tractor, and push the front wheel drive lever downward. See Figure 30.

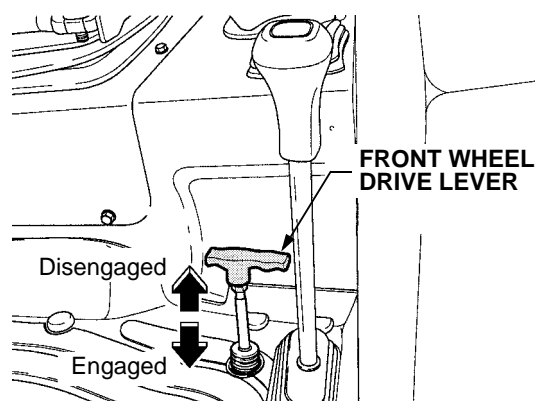

Figure 30

To disengage the front wheel drive, depress the clutch pedal and pull the lever upward.

USING THE POSITION CONTROL AND DRAFT CONTROL LEVERS

- Use the position control lever to set the height of a 3-point hitch mounted implement if drag on the tractor is not a concern.
- Set the draft control lever to control the drag on the tractor when operating a 3-point hitch mounted implement. Draft control will maintain a constant pull on the tractor by continually raising and lowering the implement as different soil conditions are experienced.
- Use a combination of the two levers to set the height of the implement while also controlling the drag on the tractor. Refer to Figure 31.

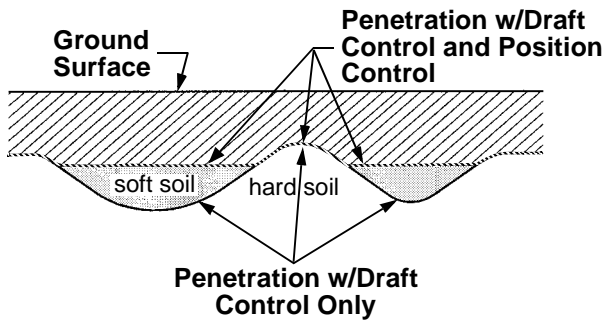

Figure 31

- After determining a desired working position using one, or both, controls, the stop bolts can be used to ensure the levers are returned to their selected positions. Loosen the wing screws and slide the stop(s) against one (or both levers) and re-tighten the wing screws. Once the stop bolt is set, simply move the relevant hydraulic lever forward until it contacts the stop. See Figure 32.

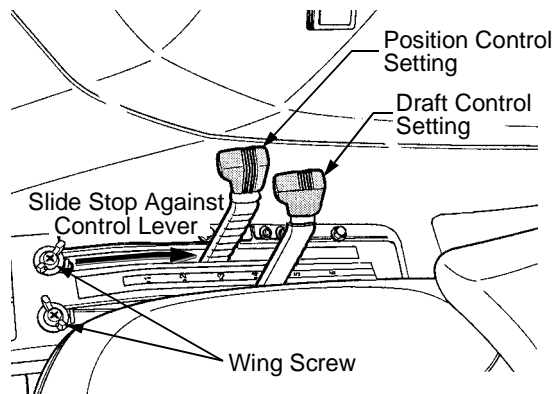

Figure 32

IMPORTANT: Do not operate the hydraulics until the engine has warmed up. If operation is attempted when the engine is still cold, the hydraulic system may be damaged.

IMPORTANT: If noises are heard when the implement is lifting after the hydraulic control lever has been activated, the hydraulic mechanism may not be adjusted properly. Contact your Cub Cadet dealer.

USING THE DRAWBAR



WARNING: Never pull from the top link of the 3-point hitch, the rear axle, or any point above the drawbar. Doing so could cause the tractor to roll over rearward causing personal injury.

Use only the drawbar for towing pull-behind equipment (carts, trailers, etc.) or dragging loads. See Figure 33.

Raise the lower links of the three point hitch to their highest position to prevent interference with the towed equipment.

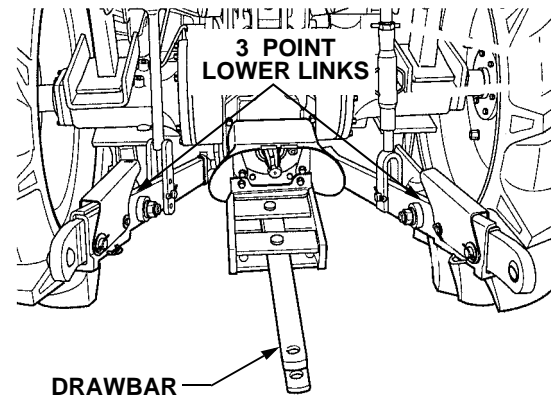

Figure 33

IMPORTANT: When transporting pull-behind equipment on public roadways, always use a safety chain to supplement the connection between the tractor and towed equipment. The safety chain must have a strength rating equal to or greater than the gross weight of the equipment being towed.

USING THE THREE POINT HITCH



WARNING: Always disengage the PTO, stop the engine, and set the parking brake before dismounting the tractor to connect, disconnect, or adjust three point hitch mounted implements. Never stand between the rear wheels and the implement when attaching and adjusting the implement.

Use the 3-point hitch only with equipment designed for 3-point hitch usage.

Top Link

- Use holes A or B in the top link holder for the top link when attaching non draft sensitive implements. See Figure 34.
- Use holes B or C in the top link holder for the top link when attaching draft sensitive implements.
- Use hole A for the top link when transporting implements.

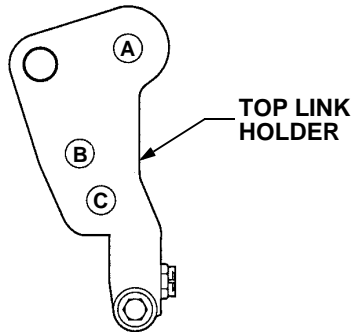

Figure 34

- Adjust the length of the top link following the information provided in the implement owner's manual.
- When an implement is not attached, pivot the center link upward and store in the top link hook on the tractor.

Lifting Rods



WARNING: Before disconnecting a lift rod from the lower link, stop the engine and lower the attached equipment to the ground. Ensure the attached equipment is safely supported and relieve any residual pressure from the hydraulic lift system by moving the hydraulic lift control levers fully rearward and forward several times.

- Following the information provided in the implement owner's manual, attach the left lift rod to the lower link using one of the three holes provided in the lift rod. Remove the internal cotter pin and clevis pin to adjust the left lift rod. See Figure 35.

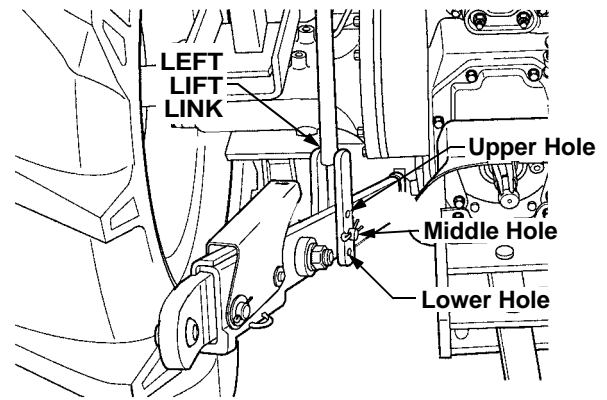

Figure 35

- Loosen the jam nut on the right lift rod and adjust its length as necessary to level the two lower links. Re-tighten the jam nut. See Figure 36.

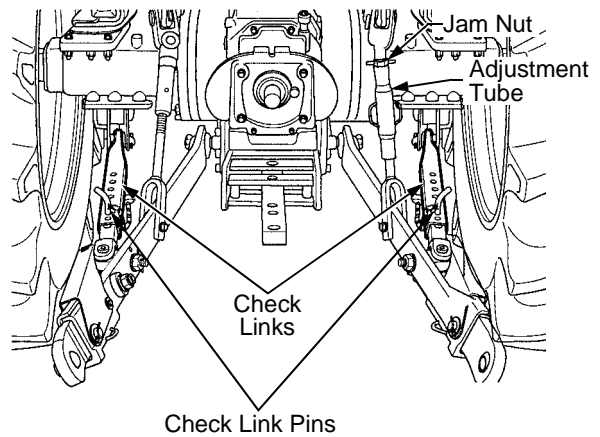

Figure 36

Check Links

Remove the pins and adjust the length of the check links to limit, or increase, the side to side movement of the lower links as suggested in the implement owner's manual.



WARNING: Keep the guard around the PTO shaft in place at all times. Replace the PTO shaft cap when the shaft is not in use.

USING REMOTE HYDRAULICS

The tractor is equipped with a remote hydraulic system for powering hydraulically driven implements that are approved for usage on the tractor.



WARNING: To avoid personal injury, stop the tractor engine and relieve pressure from the hydraulic system before connecting or disconnecting lines. Do not use your hand to check for leaks.

Connecting Implements

- Clean the hydraulic couplers on both the tractor and implement.
- Remove the dust plugs and/or caps from the couplers. See Figure 37.

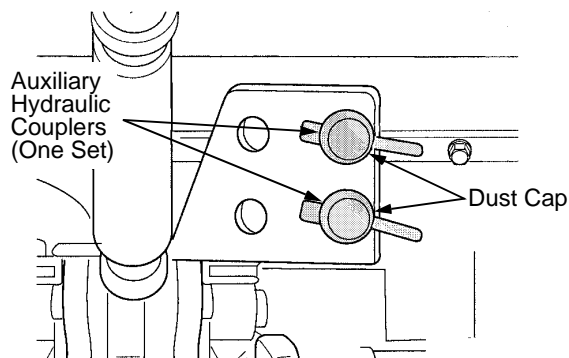

Figure 37

- Insert the implement coupler into the tractor hydraulic coupler.
- Pull slightly on the implement couplers to make certain they are firmly connected to the tractor.

Disconnecting Implements

- Lower the implement to the ground to release hydraulic pressure in the hoses.
- Relieve pressure by moving the hydraulic control lever in each direction several times with the engine shut off.
- Pull each implement hose coupler straight from the hydraulic coupler to release it.
- Clean oil and dust from each coupler and replace the dust plugs and/or caps.

Remote Control Valve Lever

Move the lever up or down and hold. This will raise or lower the implement. The lever will return to neutral when released.

IMPORTANT: Do not hold the lever in the "pull" or "push" position once the remote cylinder has reached the end of its stroke. Doing so will force oil through the relief valve, and over a prolonged period cause the hydraulic oil to overheat.

IMPORTANT: When using the tractor hydraulic system to power a front loader, do not operate the boom and bucket cylinders simultaneously.

TRACTOR WEIGHTING

When implements are installed on either the front or rear of a tractor, the tractor's normal balance is altered.

- As a rear mounted implement is raised to the transport position, the balance point of the tractor shifts rearward, which may result in a loss of steering control and tractor stability.
- When a front mounted implement is raised, the balance point shifts forward and may result in a loss of traction and stability.

To counterbalance these weight shifts, weight should be added to the tractor in the form of cast iron weights or liquid ballast. However, only enough weight should be added to obtain good traction, control, and stability. Excessive weight will unnecessarily load down the tractor's engine and transmission.

NOTE: When adding weight to the tractor, it may be necessary to increase inflation pressure in the tires.

Front Weights

To counterbalance three point hitch mounted equipment, weight should be added to the front of the tractor. Add enough ballast to maintain steering control and prevent tip over. Remove the weight when it is not needed. Front weights are available at your *Cub Cadet* dealer.

Follow the guidelines provided in the implement Operator's Manual to determine how much weight is needed to counterbalance the equipment. If guidelines are not available, ballast the tractor so that a minimum of approximately 40% of the machine weight is on the front wheels.

If necessary, contact your *Cub Cadet* dealer for help in determining how much weight is needed for your particular application.

Weighting the Rear of the Tractor

Add weight to the rear wheels if needed to improve traction or for stability. The amount of rear ballast should be matched to the job, and the ballast should be removed when it is not needed. The most common methods of adding weight are filling the rear wheels with liquid ballast or mounting a rear weight box.

Liquid Ballast

Because special equipment and a familiarity with the practice is required, only a qualified tire technician should perform this procedure. Consult with your *Cub Cadet* dealer about having liquid ballast added to your tires, and for any special maintenance instructions after the procedure is performed.

Rear Weight Box

Consult with your *Cub Cadet* dealer about available rear weight boxes. Your dealer can help in determining the positioning of the box and the amount of weight needed for your particular application.

SECTION 3: ADJUSTMENTS

ADJUSTING THE SEAT

For the comfort of the operator, a single lever adjustable seat is provided to set the fore to aft position of the seat. Adjust the seat to the most comfortable position that allows you to operate all controls and pedals.



WARNING: Do not adjust the seat when the tractor is moving, as this could cause the operator to lose momentary control of the tractor and result in an accident.

- To adjust the seat, pivot the seat adjustment lever to the left and hold while repositioning the seat to the desired position. See Figure 38.

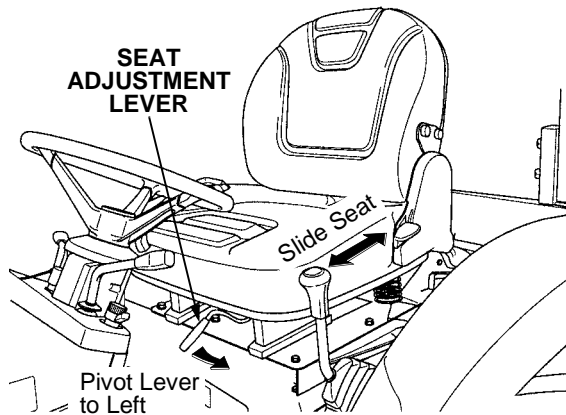

Figure 38

- After repositioning the seat, release the lever to lock the seat in position. Slide the seat either slightly forward or rearward to assure it is locked or until engagement of the lock is felt.

ADJUSTING FRONT WHEEL TOE-IN

The front wheel toe-in is set at the factory and should maintain the proper setting. However, the toe-in should be checked periodically and readjusted if necessary.

CHECK THE TOE-IN AS FOLLOWS:

- Place the tractor on a level surface with the wheels in the straight ahead position.
- Place an easily visible mark at the front and rear center lines of both front tires, preferably at the horizontal center line of the wheel.
- Measure and record the distance 'A' between the two front marks. Then measure and record the distance 'B' between the two rear marks. See Figure 39.

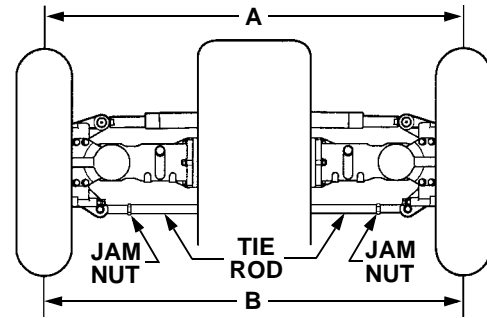

Figure 39

- Distance 'A' should be .08" to .31" less than distance 'B' if the toe-in is correct. If it is not, adjust the toe-in.

READJUST THE TOE-IN AS FOLLOWS:

- Loosen the jam nuts at both ends of the tie rod. Refer to Figure 39.
- Turn the tie rod in either direction to adjust its length.
 - Shorten the tie rod to increase distance 'A' and decrease the toe-in.
 - Lengthen the tie rod to decrease distance 'A' and increase the toe-in.
- Adjust the tie rod as necessary to obtain the correct toe-in, then tighten the jam nuts.

ADJUSTING FRONT AXLE

Looseness or play in the front axle may cause serious trembling of the front wheels and vibration of the steering wheel. Check and adjust the front axle as follows:

- Raise and support the front of the tractor so that the front wheels are just off the ground.
- Check the front axle for any front to back play.
- If play is felt, loosen the jam nut on the adjusting bolt in the center of the front axle support. See Figure 40.

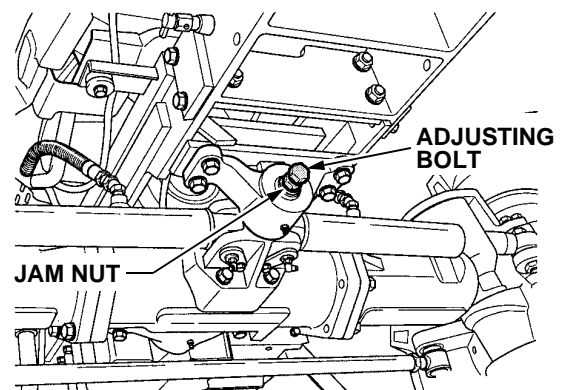

Figure 40

- Tighten the adjusting bolt as necessary to remove the play from the front axle, then retighten the jam nut.
- Lower the front of the tractor to the ground.

ADJUSTING THE FAN BELT TENSION

If the fan belt becomes loose, the engine may overheat and/or the battery may not charge. Check the belt tension and, if necessary, adjust as follows:

- With approximately 22 lbs. of pressure, depress the backside of the belt at its center point between the alternator and lower engine pulley. The deflection of the belt should be approximately 0.3 inches. See Figure 41.

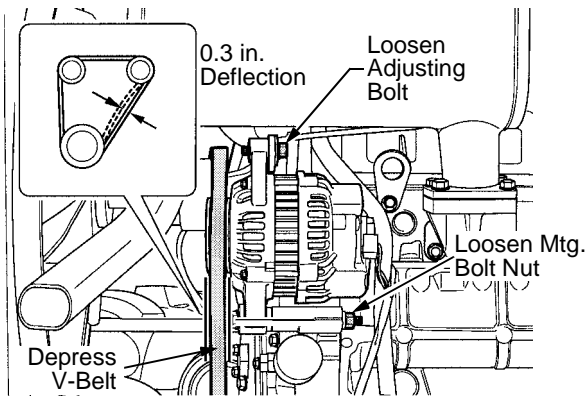

Figure 41

- If adjustment is needed, loosen the nut on the alternator mounting bolt and loosen the adjusting bolt. See Figure 41.
- Pivot the alternator to acquire the correct belt tension and re-tighten the adjusting screw and mounting fasteners.

BRAKE ADJUSTMENT

Moderate brake pedal play, as measured at the end of the pedals, ranges from 0.98 to 1.57 inches (25 to 40 mm). If the brake pedals need adjustment, proceed as follows:

- Loosen the jam nuts from the turnbuckle on both the left and right brake adjustment rods. See Figure 42.
- Turn the turnbuckle on each rod until both the right and left brake pedals are within the acceptable range of play. See Figure 42.
- Tighten the jam nuts after adjusting the turnbuckles.
- Interlock and depress both brake pedals and check that the parking brake engages properly.

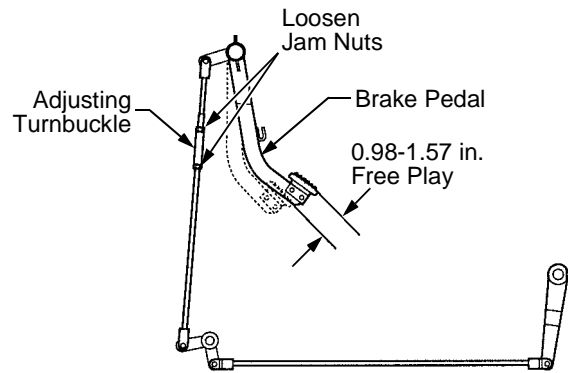

Figure 42

IMPORTANT: The brake pedals should be adjusted in such a manner that the levels of the right-hand and left-hand brake pedals are uniform. If they are not uniform, the brakes may work excessively to one side when they are depressed simultaneously.

CLUTCH ADJUSTMENT

Moderate clutch pedal play ranges from 1.57 to 1.96 inches (40 to 50 mm) as measured at the end of the pedal. If it becomes difficult to disengage the clutch or pedal play decreases, adjust the length of the clutch rod. From inside the left side panel, remove the internal cotter pin and clevis pin to disconnect the clutch rod. If the clutch is difficult to disengage, shorten the rod. If there is too little play in the clutch pedal, lengthen the rod. See Figure 43.

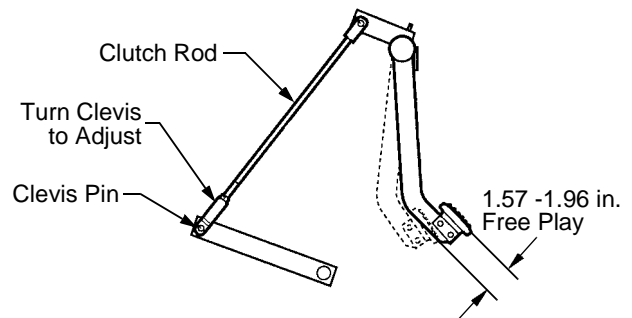

Figure 43

IMPORTANT: Free travel of the clutch pedal is governed by the clearance between the clutch's release thrust bearing and the release levers. This clearance is set from 0.098 to 0.12 inches (2.5 to 3 mm) when the tractor is built, but this changes as the tractor is used. If the pedal is used with no clearance, it will result in the seizure of the release bearing or wear of the facing. Therefore, be sure to check and adjust at the intervals called for in the maintenance schedule.

To Adjust

- Open the clutch access window which is located on the right front of the clutch housing.
- Insert a 0.098 to 0.12 inch (2.5 to 3.0 mm) feeler gauge between the release thrust bearing and the release levers. Adjust the clearance by adjusting the length of the clutch rod.
 - Lengthen the rod if the clearance is wider than the specification.
 - Shorten the rod if the clearance is less than the specification.
- Depress the clutch pedal and check to make certain that the free travel at the tip of the pedal is 1.57 to 1.96 inches (40 to 50 mm).
- With the clutch pedal fully depressed, confirm that there is adequate gap between the clutch rod and the safety start switch.

IMPORTANT: When adjusting the clutch pedal free travel, always use measuring devices rather than visually estimating distances.

ADJUSTING THE MICRO SWITCH HEIGHT

The PTO micro switch, located on the right fender aside the position control lever, is initially set so that the PTO will disengage when the 3-point hitch lower links are raised to approximately 23.6 to 26 inches. See Figure 44.

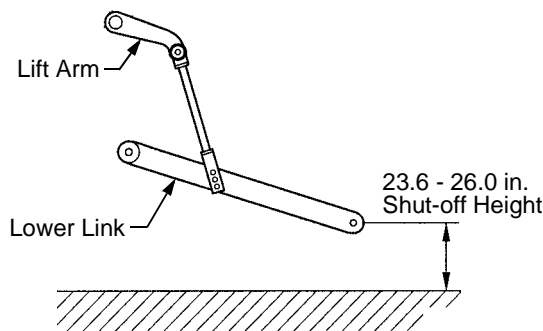

Figure 44

If your application requires the PTO to run with the lower links at a height above 23.6 to 26 inches, the micro switch position can be adjusted as follows:

- Loosen the screws securing the micro switch mounting bracket. Refer to Figure 45.

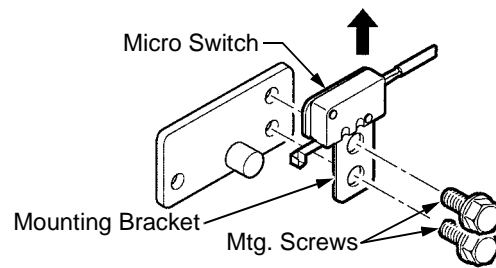

Figure 45

- Raise the switch slightly and recheck the position of the lower links when the PTO shuts off.
- If necessary, repeat the above step until the PTO shut-off height of the lower links is adequate for your application. The switch can be adjusted so that the lower links can be raised to approximately 35.8 inches before the PTO will be disengaged.

ADJUSTING WHEEL TREAD

When operating the tractor in the field, it is sometimes necessary to change the rear wheel tread to a narrower position to avoid plant rows, or to widen the tread to improve stability when operating on slopes. The rear wheel tread width can be adjusted to any of 6 different positions ranging from 46.4 to 58.6 inches by changing the position of the wheel disc relative to the rim mounting brackets and the rear axle.

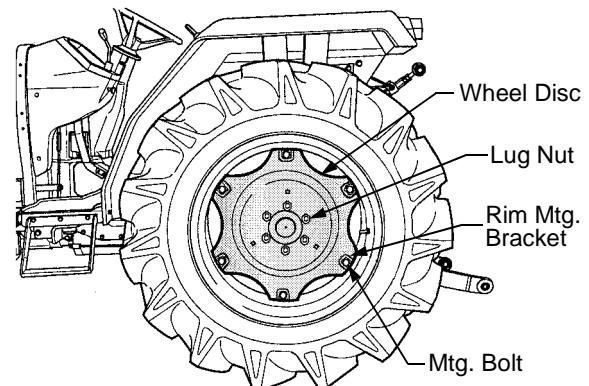

Figure 46

IMPORTANT: The front wheel tread width cannot be adjusted. Attempting to do so will cause damage to the tractor. If removed, torque front wheel lug nuts to 57.2 - 66.5 ft. lbs.

To Adjust



WARNING: Never operate the tractor with loose wheel assembly fasteners. Always tighten the fasteners to the specified torque, and frequently check that they are tight.

IMPORTANT: When changing the tread width of the rear wheels, you must pay attention to the direction of the tire's tread design and make certain to maintain that direction. To do this, it will at times be necessary to switch wheel assemblies from one side of the tractor to the other.

- Raise and support the rear of the tractor.
- Adjust the tread widths as shown by changing the mounting relationship of the wheel disc to the rim mounting brackets and/or the relationship of dish of the wheel disc to the axle. See Figure 47.

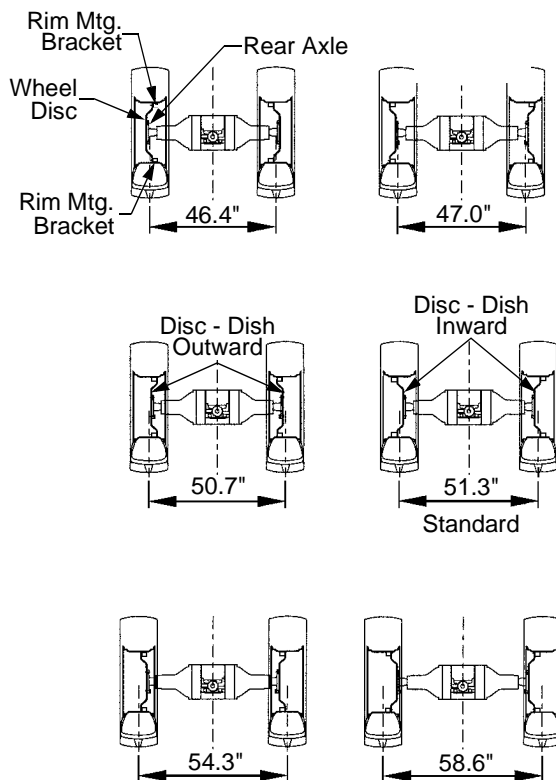

Figure 47

- Torque the nuts to 145-165 ft. lbs. (196-226 N•m).
- Raise the rear of the tractor, remove the supports, and lower the tractor to the ground.

CHECKING STEERING WHEEL

If it is difficult to drive the tractor in a straight line, check the play in the steering wheel. Acceptable steering wheel play is 0.8 to 2.0 inches (24 to 50 mm) as measured at the outer circumference of the steering wheel. If your steering wheel free play exceeds the acceptable range, contact your Cub Cadet dealer to have the tractor inspected.

Acceptable Steering Wheel Play
0.8 - 2.0 in.

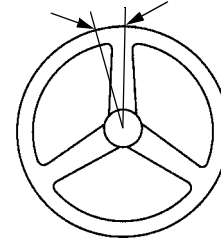

Figure 48

SECTION 4: MAINTENANCE

The service life and reliability of any machine depends upon the care it is given. Proper lubrication and maintenance is a vital part of that care. Using the *Lubrication and Maintenance Chart* as a guide, monitor the hourmeter on the instrument panel to ensure the required maintenance procedures are performed. The maintenance schedule reflects the minimal requirements to maintain the equipment. More frequent inspections and maintenance is preferable.

Make certain that all lubrication fittings are installed and functioning. Wipe away all old grease and dirt from the lube fittings to prevent foreign materials from entering as the new grease is applied. Use a

pressure lubricating gun to force in new grease. Apply pressure until clean grease emerges from the lubrication point.

Miscellaneous working parts not provided with lubrication fittings should be oiled regularly with a good grade of lubricating oil.

Lubricant is cheap. Use plenty of it. Worn parts can be expensive to replace.

Store your supply of lubricating grease and oil in clean, covered containers to protect them from dust and dirt. Keep the lubricating gun nozzle clean.

LUBRICATION TABLE

Application	Type of Lubricant	General Information			
		Capacity	API Classification	SAE Viscosity	Description
Engine	Engine Oil	Approx. 7.6 Qts w/Filter	CC or CD	15W-40	Cub Cadet 737-3039 (1Qt.)
Transmission and Hydraulic System	Hydraulic Transmission Fluid	Approx. 36 Qts. (9.0 Gal.)			<u>Alternate Oils Shown Below</u> Shell — Donax-TD or Donax-TM Mobil — Mobil Fluid 423 Exxon — Torque Fluid 56
Front Wheel Drive Axle	Gear Lube	Approx. 8.8 Qts. (2.2 Gal.)			SAE80 or SAE90 Gear Oil
Lube Fittings	Grease	As Needed	Use Cub Cadet 251H EP Grease 737-3034 (14.5 Oz. Cartridge)		
Radiator and Overflow Reservoir	Antifreeze	Approx. 2.4 Gal.	Use High Quality Permanent Type Antifreeze (Ethylene Glycol with corrosion and rust inhibitor chemicals) Coolant Mixture Ratio Distilled Water 50% : Antifreeze 50%		

LUBRICATION AND MAINTENANCE CHART

No.	Operation to be Performed	Service Intervals														
		Before each use	50 Hours	100 Hours	150 Hours	200 Hours	250 Hours	300 Hours	350 Hours	400 Hours	450 Hours	500 Hours	550 Hours	600 Hours	1 Year	2 Years
1	Check Engine Oil Level	•														
2	Check and Clean Air Cleaner	•														
3	Check Engine Coolant Level	•														
4	Check Transmission Oil Level	•														
5	Check and Clean Radiator Screen	•														
6	Check Oil Level of Front Axle and Final Drive Gear Cases	•														
7	Check and Clean Fuel Filter			•	•	•	•	•	•	•	•	•	•	•		
8	Change Engine Oil and Replace Oil Filter		†	•	•	•	•	•	•	•	•	•	•	•		
9	Change Oil in Front Axle and Final Drive Cases (both sides)		†				•							•		
10	Replace Transmission and Hydraulic Oil and Oil Filter		†				•							•		
11	Replace Air Cleaner Element			•	•	•	•	•	•	•	•	•	•	•		
12	Change Engine Coolant														•	
13	Replace Fuel Filter Element								•							
14	Check Oil Pressure Lines and Fuel Lines for Tightness		•	•	•	•	•	•	•	•	•	•	•	•	•	
15	Check Radiator Hoses for Tightness				•			•			•			•		
16	Check Air Cleaner Hose for Tightness						•				•					
17	Check Fan Belt Tension			•	•	•	•	•	•	•	•	•	•	•		
18	Replace Fuel Line															•
19	Replace Radiator Hoses															•
20	Replace Hydraulic Hose															•
21	Replace Hydraulic Couplers															•
21	Drain Clutch Housing		•	•	•	•	•	•	•	•	•	•	•	•	•	
22	Grease Lubrication Points		•	•	•	•	•	•	•	•	•	•	•	•	•	

† First 50 hours



WARNING: Use care when servicing any component in the engine area. If the engine has recently been operated, components will be hot and could cause burns. Allow the engine to cool before servicing.



WARNING: Before servicing the engine, place the tractor on a level surface, stop the engine, engage the parking brake, and remove the key from the ignition switch.

ACCESSING THE ENGINE COMPARTMENT

Opening the Front Grille

To open the front grille, turn the latch knob at the front of the hood and pivot the top of the grille forward. See Figure 49.

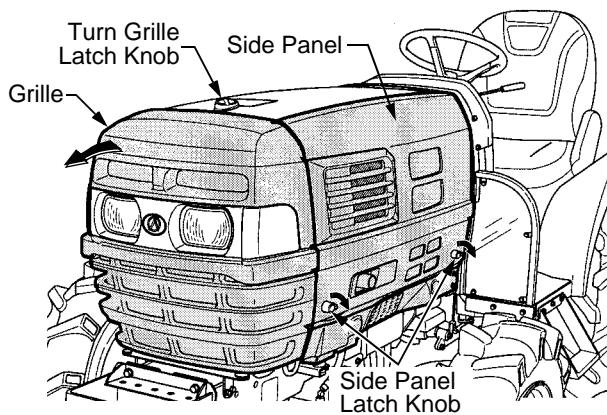

Figure 49

To close the grille, pivot the grille upward and align its latch bracket with the slot in the hood. Push the grille rearward until it locks.

Removing the Side Panels

- Locate the two latch knobs at the bottom corners of the side panel and turn the handle of the knobs downward. Refer to Figure 49.
- Pull the bottom of the side panels slightly outward and securely grasp the panel while lifting it straight upward to remove.

Installing the Side Panels

- Position the side panel and lower its top flange into the slot of the hood.

- Pivot the bottom of the side panel inward while making certain the pins of the latch knobs align with the latch springs on the tractor.
- Press the latch knobs inward and turn the handle upward to lock the side panel in place.

NOTE: It may be necessary to firmly push the latch knobs inward to lock in the latch springs.

FUEL SYSTEM

Checking and Refilling



WARNING: Stop the engine before adding fuel. Keep away from sparks and flames.



WARNING: Never fill the fuel tank to the top of the filler neck. Expansion could result in overflow through the cap vents, allowing fuel to come in contact with hot surfaces, which could cause a fire.

IMPORTANT: If the fuel tank becomes empty, air is admitted to the fuel system. If air enters the fuel system, it must be eliminated before the engine can be started.

When filling the fuel tank, always use a strainer to prevent contaminants from entering the fuel system and possibly causing fuel injection pump contamination.

- Check the fuel level before each use. Take care that the fuel tank is not allowed to become empty. See Figure 50.

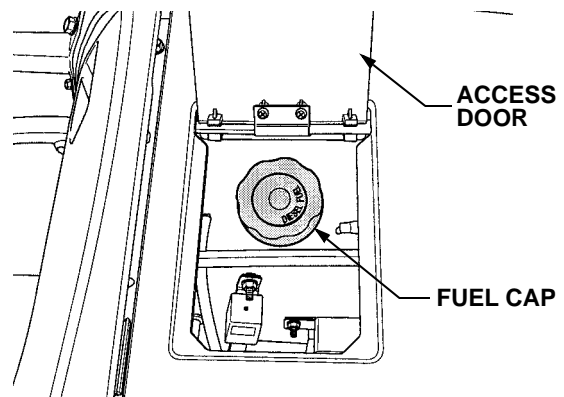

Figure 50

- Use No. 2 diesel fuel. Use No. 1 diesel fuel if the temperature is below 15° F (-10°C).
- The fuel tank capacity is approximately 10.6 gal. Do not overfill.

Bleeding the Fuel System



WARNING: Do not bleed the fuel system when the engine is hot.

Air must be bled from the fuel system when the fuel filter or fuel lines are removed; the fuel tank is completely emptied; or the tractor has not been used for a long period of time.

- Fill the fuel tank with No. 2 diesel fuel and make certain the shut-off valve on the fuel filter is open.
- Loosen the air vent cock on the injection pump two or three turns by hand, then start to turn the engine over. See Figure 51.

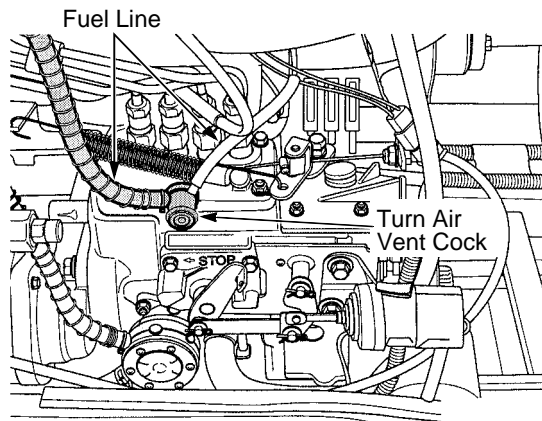

Figure 51

- When there are no more air bubbles in the fuel line, tighten the air vent cock.

Servicing the Fuel Filter



WARNING: When servicing the fuel filter element, take all precautions to prevent dust or dirt from entering the fuel system. Contaminants will cause premature wear and/or malfunction of the injection pump and injection nozzles.

The fuel filter should be cleaned after every 100 hours of operation, and replaced after every 400 hours.

- Make certain the area is free of dust and dirt.
- Close the shut-off valve on the fuel filter. See Figure 52.

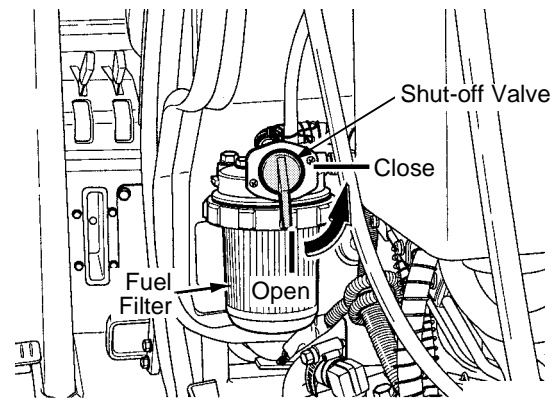

Figure 52

- Unscrew the retaining ring and remove the ring and fuel filter bowl from the filter. Use care not to lose the O-ring and spring. See Figure 53.

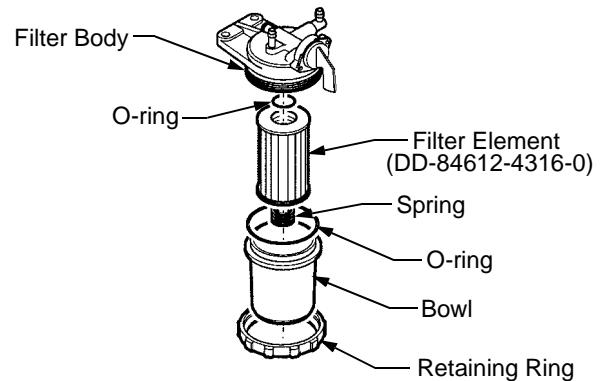

Figure 53

- Flush the bowl out with clean diesel fuel.
- Remove the element and either dip it into a container of clean diesel fuel to clean it, or replace it with a new element.
- Install the new, or cleaned, element onto the filter body.
- Install the filter bowl and retaining ring over the element, and tighten the retaining ring to secure.
- Bleed the air from the fuel system using the air vent cock on the injection pump. Refer to Figure 51.

Checking the Fuel Lines



WARNING: The fuel line hoses are subject to wear and natural aging. A leaking fuel line may allow fuel to come into contact with sources of ignition, and could cause a fire.

The condition of the fuel line hoses and clamps should be checked every 100 hours or six months (whichever occurs first), and they should be replaced every two years. Refer to Figure 51.

- Stop the engine before checking the fuel line hoses and clamps.
- Check that the fuel line hose clamps are snugly securing the hoses to their respective fittings. Replace any damaged clamps.
- Check the fuel hoses for wear or deterioration, and any damaged hoses should be replaced immediately.
- After replacing a fuel line, it will be necessary to bleed air from the fuel system before starting the engine.

IMPORTANT: When servicing the fuel line hoses and clamps, care should be taken to prevent dirt or dust from entering the fuel system. If replacing a fuel line hose, inspect the new hose to make certain no dirt or debris has entered the hose.

ENGINE OIL AND OIL FILTER

Checking the Engine Oil Level

Check the engine oil level before each use. If checking the oil level after running the engine, wait at least 5 minutes after stopping the engine to get an accurate reading.

- Remove the left side panel.
- Clean the area around the dipstick to prevent debris from entering the crankcase; then withdraw the dipstick from the engine and wipe clean. See Figure 54.

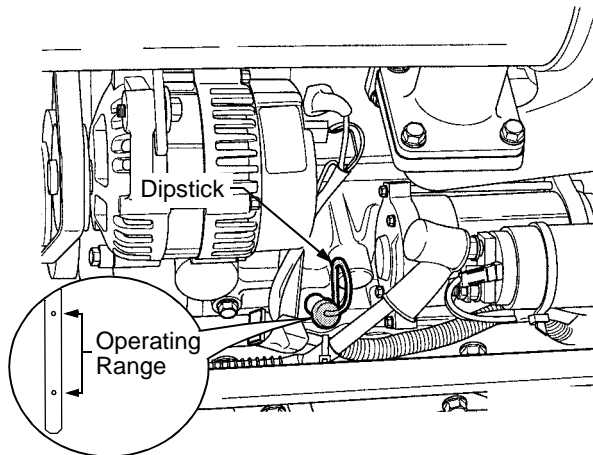

Figure 54

- Fully re-insert the dipstick into the engine.
- Withdraw the dipstick again, and check that the oil level is between the upper and lower marks on the dipstick. Always keep the oil level between the full and add marks on the dipstick.
- Reinsert the dipstick into the engine and press firmly into place.

Adding Engine Oil

If the oil level is low, add enough oil to bring the level up to the full mark on the dipstick. Do not overfill the crankcase. Refer to the LUBRICATION TABLE for the proper type of oil to add to the crankcase. When possible, maintain the brand and viscosity of oil previously used to service the engine.

- Place the tractor on a level surface and engage the parking brake. Stop the tractor engine and remove the ignition key.
- Clean the area around the oil filler cap to prevent debris from entering the crankcase.

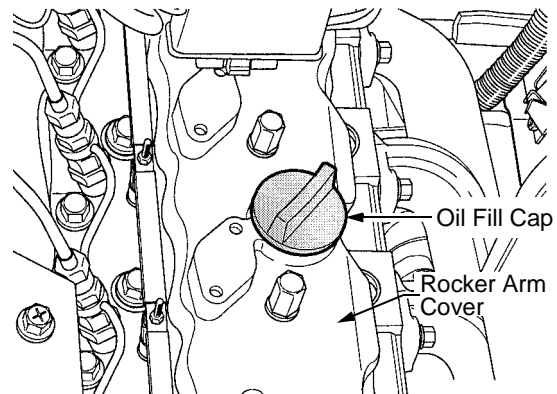

Figure 55

- Turn the oil filler cap counterclockwise to unscrew from the rocker arm cover.
- SLOWLY pour oil into the crankcase until the oil level reaches the "FULL" mark on the dipstick.
- Insert the oil fill cap into the rocker arm cover and turn clockwise until fully tightened. Reinsert the dipstick into the engine and push firmly into place.

IMPORTANT: The oil fill cap and dipstick must always be installed securely in place when the engine is running. Severe engine damage could result from failure to do so.

Changing Engine Oil and Filter

The engine oil and oil filter (located on the right/front of the engine) should be changed after the first 50 hours of operation, then at 100 hours and every 100 hours thereafter. Refer to the LUBRICATION TABLE for the quantity and type of oil needed.



WARNING: Because the engine is run prior to draining the oil, the engine may be hot. Use caution to avoid burning yourself on engine surfaces.

Run the engine for a few minutes to allow the oil in the crankcase to warm up. Warm oil will flow more freely and carry away more engine impurities. Use care to avoid burns from hot oil. While the engine oil is warm, proceed as follows:

- Place the tractor on a level surface and engage the parking brake. Stop the tractor engine and remove the ignition key.
- Clean around the base of the oil filter, the oil filler cap, and the dipstick to prevent debris from entering the crankcase.
- Remove the dipstick and oil fill cap from the engine. Refer to Figure 54 and Figure 55.
- Locate the engine drain plugs on the bottom of the engine. Place a suitable container below the drain plugs to collect the old oil. See Figure 56.

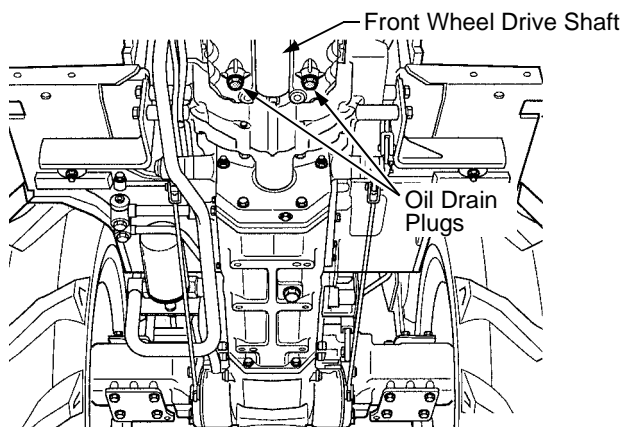

Figure 56

- Turn the drain plugs counter-clockwise to remove from the engine.
- Allow the old oil to completely drain from the engine crankcase into the container below.

- Move the drain pan beneath the filter, then remove the filter by turning it counterclockwise using a filter wrench to loosen. See Figure 57.

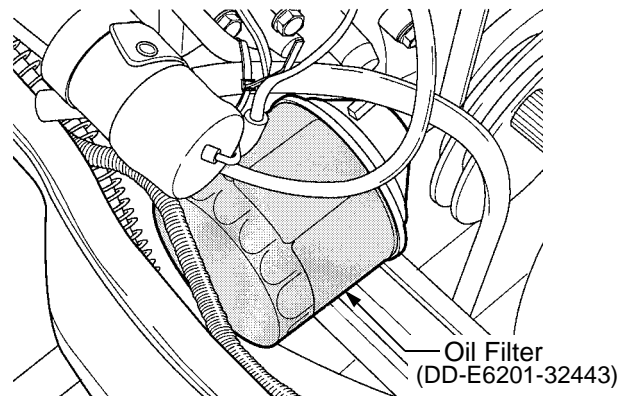

Figure 57

- Reinstall the drain plugs in the engine and clean up any residual oil.
- Apply a light coating of clean oil on the gasket of the new oil filter. Thread the filter onto the engine and tighten by hand.
- Refill the crankcase to the "FULL" mark on the dipstick with the appropriate type oil.
- Reinstall the oil fill cap and dipstick.
- Start and run the engine for a few minutes to check that the engine oil pressure light goes out and to circulate oil throughout the engine. Stop the engine and check for leaks at the oil filter and drain plug.
- Wait 3 minutes and re-check the oil level. If needed, add oil to bring the oil level up to the "FULL" mark.



WARNING: Never overfill the engine crankcase. For best results, fill to the "FULL" mark on the dipstick as opposed to adding a given quantity of oil. Always check the level on the dipstick before adding more oil.



Dispose of used oil in an environmentally safe manner. If necessary, contact your area EPA office for proper disposal procedures and recycling center locations.

IMPORTANT: The oil fill cap and dipstick must always be installed securely in place when the engine is running. Severe engine damage could result from failure to do so.

TRANSMISSION OIL AND OIL FILTER

Checking the Transmission Oil Level

Check the hydro transmission/hydraulic system oil level before each use. Check the oil level only while the engine is stopped and the tractor is standing on a level surface.

- Locate the transmission dipstick on the rear of the transmission at the back of the tractor. See Figure 58.

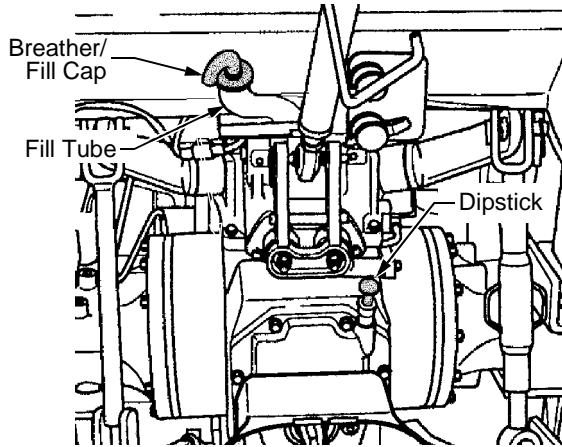

Figure 58

- Clean the area around the dipstick to prevent debris from entering the transmission; then withdraw the dipstick from the transmission and wipe clean.
- Fully re-insert the dipstick into the transmission.
- Withdraw the dipstick again, and check the oil level. Always keep the oil level between the full and add marks on the dipstick.
- If the oil level is low, refer to the LUBRICATION TABLE for the proper type and quantity of oil to add to the transmission.
- Clean the area around the breather cap and fill tube on the back of the transmission to prevent debris from entering the transmission. Then turn the cap counterclockwise to unscrew from the oil fill tube. Refer to Figure 58.
- Slowly pour transmission oil into the fill tube while frequently checking the oil level with the dipstick. Add only enough oil to bring the oil level up to the full mark on the dipstick.

- Screw the breather cap into the fill tube, and reinsert the dipstick into the transmission and press firmly into place.

Changing the Transmission Oil and Filter

The oil in the transmission case is also used for the hydraulic system. The transmission/hydraulic oil and the oil filter (located on right side of tractor) should be changed after the first 50 hours of operation, then at 300 hours and every 300 hours thereafter. Refer to the LUBRICATION TABLE for the quantity and type of oil needed.

- Clean the area around the transmission dipstick and breather cap to prevent debris from entering the transmission. Refer to Figure 58.
- Locate the drain plug on the bottom of the transmission. Place a suitable container below the drain plug to collect the old oil. See Figure 59.

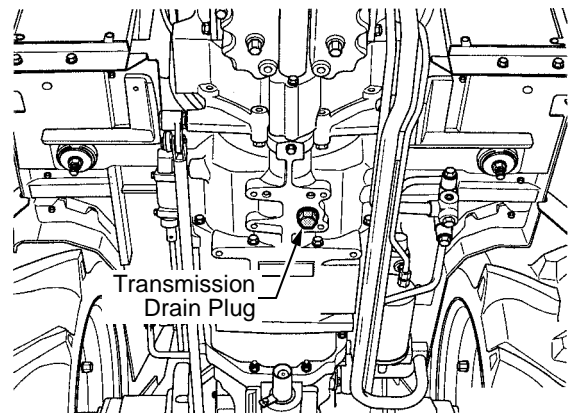

Figure 59

- Remove the dipstick and breather cap from the transmission.
- Turn the drain plug counter-clockwise to remove from the transmission, and allow the old oil to completely drain from the transmission. **NOTE:** *The capacity of the transmission is approximately 9 gallons (36 qts.), so it may be necessary to drain the transmission in stages to capture the used oil and/or to ease emptying the drain pan.*

- Move the drain pan beneath the filter, then remove the filter by turning it counterclockwise using a filter wrench to loosen. See Figure 60.

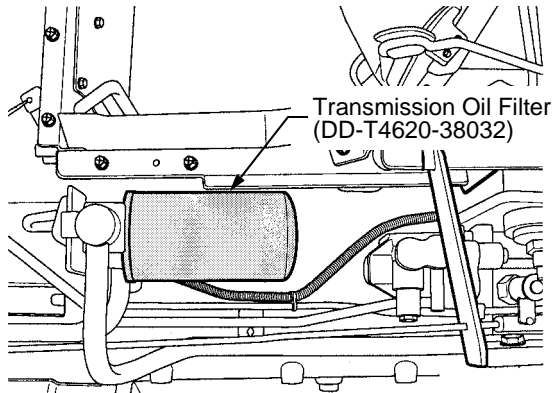

Figure 60

- Use a clean rag to clean the metal surface of the filter base where the filter gasket makes contact.
- Reinstall the drain plug in the transmission and clean up any residual oil.
- Apply a light coating of clean oil on the oil filter gasket and on the sealing surface of the base. Install the filter by turning it clockwise, by hand, until the gasket contacts the filter base; then tighten the filter an additional 1/2 to 3/4 turn.
- Slowly pour transmission oil into the fill tube while periodically checking the oil level with the dipstick. Fill the transmission to the full mark on the dipstick.
- Screw the breather cap into the fill tube and reinsert the dipstick into the transmission and press firmly into place.
- Start the engine and run at low to mid throttle for approximately 5 minutes while actuating the hydraulics (e.g. power steering and hydraulic lift).

IMPORTANT: Do not drive the tractor immediately after changing the transmission oil and filter. Run the engine for 5 minutes to prevent damage to the transmission and/or hydraulic system.

NOTE: If hydraulically driven equipment, such as a front loader, is installed on the tractor after the first 50 hours of operation, it is recommended that the filter again be changed after the first 50 hours of operation of that equipment.



Dispose of used oil in an environmentally safe manner. If necessary, contact your area EPA office for proper disposal procedures and recycling center locations.

SERVICING THE FRONT AXLE

Check the oil level in the front axle frequently. Change the oil in the front axle after the first 50 hours of operation, then at 300 hours and every 300 hours thereafter.

Checking the Front Axle Oil Level

To check the front axle oil level, a viewing glass is provided in the axle. The oil level should be approximately half way up in the viewing glass. See Figure 61.

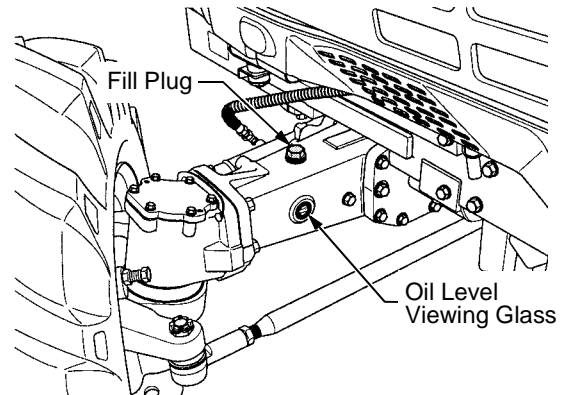

Figure 61

Adding Front Axle Oil

If the oil level is low, refer to the LUBRICATION TABLE for the proper type and quantity of oil to add to the front axle. Add oil through the oil fill port on top of the axle. Refer to Figure 61.

Changing the Front Axle Oil

- After cleaning the area, remove the oil fill plug from the top of the axle. Refer to Figure 61
- Place a suitable container below the drain plugs, then remove the plugs from the center of the front axle and the final drives inside both wheels. See Figure 62

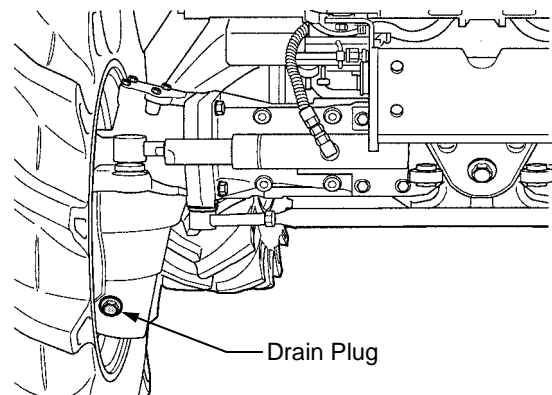

Figure 62

- Replace the drain plugs and slowly fill the front axle through the fill port until the oil level is approximately half way up in the viewing glass.

SERVICING THE AIR CLEANER

Check the air cleaner dust cup and element before each use. Clean the dust out of the cup and blow off the element weekly. Replace the element after every 100 hours of operation.

NOTE: *The air cleaner uses a dry element, never apply oil.*

- Unclip the two retainers to remove the cup and wipe out any build-up of dust. See Figure 63.

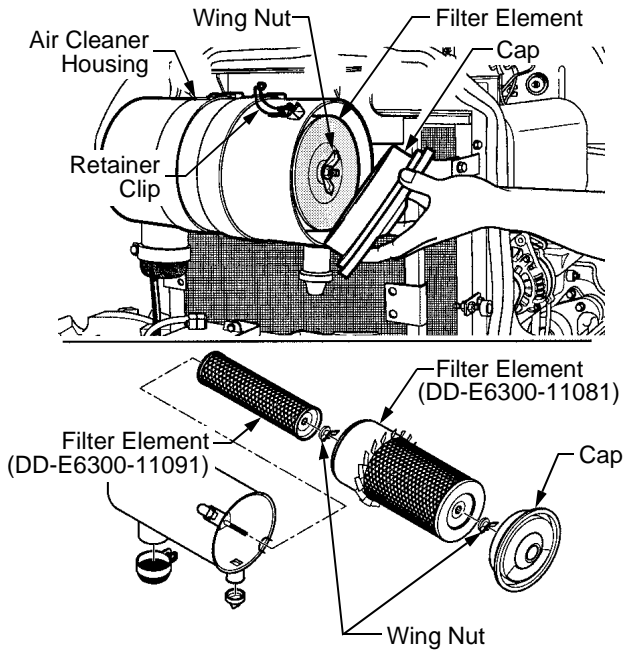

Figure 63

- Remove the wingnut and carefully withdraw the filter element from the housing. See Figure 63.
- To clean the element, use clean dry compressed air on the inside of the element. Air pressure at the nozzle must not exceed 29 PSI and the nozzle must be held a reasonable distance from the element.

- Remove the second wingnut and carefully withdraw the secondary filter element from the housing. Gently blow or brush any dirt from the element.
- Using care not to damage the elements, insert the new, or cleaned, elements into the housing and secure each with a wingnut.
- Install the cup and secure with the two retainers.

IMPORTANT: *The air cleaner will only fulfill its function if correctly and regularly maintained. A poorly maintained air cleaner will mean loss of power, excessive fuel consumption and a reduction in engine life.*

DRAINING THE CLUTCH HOUSING

The clutch housing should be checked and, if necessary, drained of any water after every 50 hours of operation. The clutch housing should also be checked if the tractor has been operated in inclement weather or in wet fields with standing water, or has been hosed off.

Remove the drain plug in the bottom of the clutch housing to drain. If water is drained, allow the inside of the clutch housing to dry. See Figure 64.

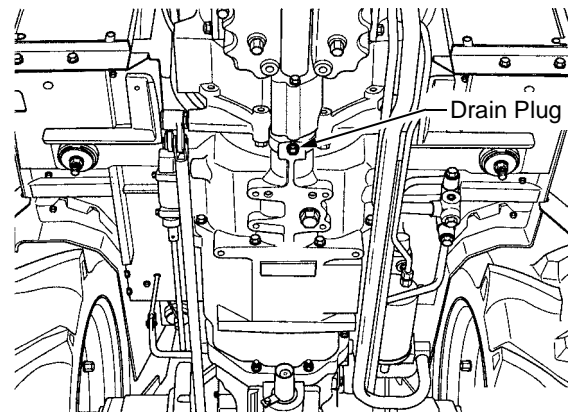

Figure 64

SERVICING THE COOLING SYSTEM

Before each use, the engine coolant level in the overflow reservoir should be checked to ensure it is within the operating range. Engine coolant absorbs heat from the engine and transfers the heat to the air flowing through the radiator. If the coolant level becomes low, the engine may overheat and could cause severe damage to the engine.

Use a permanent type antifreeze containing corrosion and rust inhibitors. Dilute the antifreeze with water at a 1:1 ratio to mix the coolant solution (50% antifreeze : 50% water).

Checking and Adding Coolant

Check the coolant level in the overflow reservoir before each use. See Figure 65.

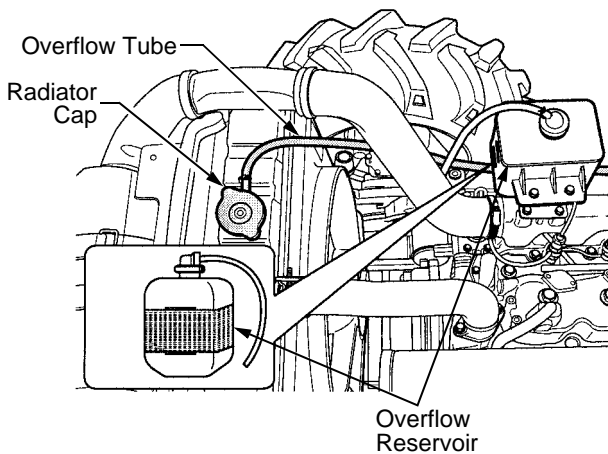

Figure 65

If the level is below the lower line on the reservoir, add coolant to the reservoir as follows:

- If coolant level is low due to evaporation, refill with water only.
- If coolant level is low due to leakage, refill with the appropriate mixture of anti freeze and water.

If the reservoir is empty, the coolant level in the radiator should be checked before operating the tractor. Proceed as follows:



WARNING: It is dangerous to remove the radiator cap when the system is hot. Allow the system to cool before removing the radiator cap.

- Locate the radiator cap beneath the access door at the forward end of the hood. Turn the radiator cap counterclockwise to the first stop to release any pressure. Refer to Figure 65.
- Push downward on the cap and turn counterclockwise until the cap stops then lift cap off.
- Slowly pour coolant mixture into the filler neck until the level reaches the bottom of the filler neck overflow flange.
- Wait a few minutes to allow as much air as possible to escape through the filler neck, then reinstall the radiator cap.
- Fill the overflow reservoir to the "FULL" mark.
- Start the engine and allow it to run for a short period. Stop the engine.
- Recheck the coolant level in the overflow reservoir and refill as needed. Reinstall the reservoir cap.

Checking and Cleaning Radiator Screen

The radiator screen is designed to catch debris, and prevent it from clogging the air passages between the radiator cooling fins. See Figure 66.

Check the radiator screen daily and blow off any minor accumulations of debris using compressed air directed from the fan shroud side of the radiator.

NOTE: During certain times of year it may be necessary to clean the screen more often.

If the screen becomes extremely dirty, remove the wing bolt and slide the screen out from the right side of the tractor. Flush the screen with water. Reinsert the screen and secure with the wing nut.

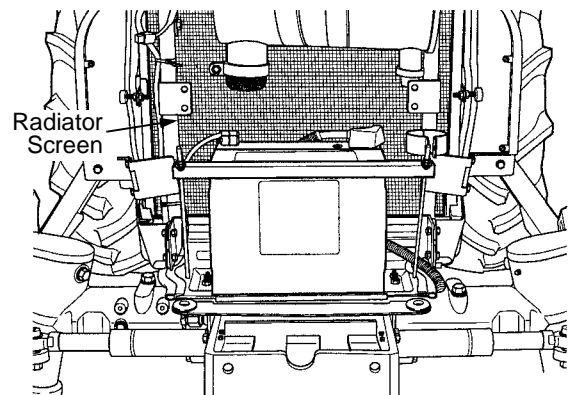

Figure 66

Changing the Coolant

The anti freeze and water coolant solution should be changed every year. The cooling system capacity is approximately 2.4 gallons.



WARNING: It is dangerous to remove the radiator cap when the system is hot. Allow the system to cool before removing the radiator cap.

- Locate the radiator drain cock on the right side of the front axle frame. Place a suitable container beneath the drain cock. See Figure 67.

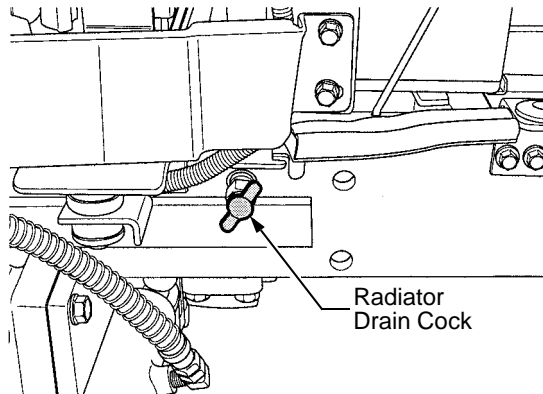

Figure 67

- Open the radiator drain cock and remove the radiator cap. The radiator cap must be removed to completely drain the radiator.
- Close the radiator drain cock.
- Slowly pour coolant mixture into the filler neck of the radiator until the level reaches the bottom of the filler neck overflow flange.
- Wait a few minutes to allow as much air as possible to escape through the filler neck, then reinstall the radiator cap.
- Fill the overflow reservoir to the "FULL" mark.
- Start the engine and allow it to run for a short period. Stop the engine.
- Recheck the coolant level in the overflow reservoir and refill as needed. Reinstall the reservoir cap.



Dispose of used coolant in an environmentally safe manner. If necessary, contact your area EPA office for proper disposal procedures and recycling center locations.

Checking the Radiator Hoses

Check the condition of the radiator hoses and the tightness of the hose clamps every 150 hours of operation. Replace a damaged hose and tighten the hose clamps if loose. See Figure 68.

It is recommended that the hoses and, if necessary, the hose clamps be changed every two years.

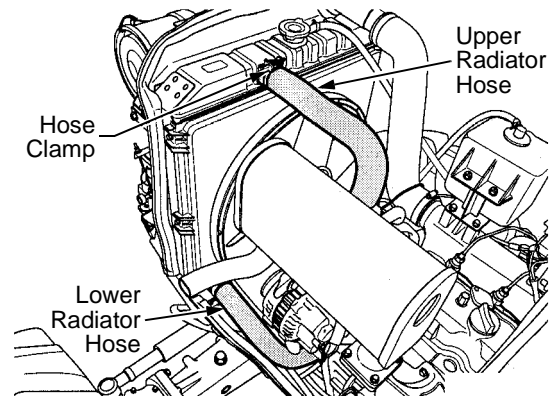

Figure 68

LUBRICATING THE TRACTOR

After every 50 hours of operation apply Cub Cadet 251HEP grease (or equivalent) to all lube fittings.

Wipe away all old grease and dirt from the lube fittings to prevent foreign materials from entering as the new grease is applied. Use a pressure lubricating gun to force new grease through the lube fittings of the following tractor components:

- Front axle pivot brackets (front and back). See Figure 69.

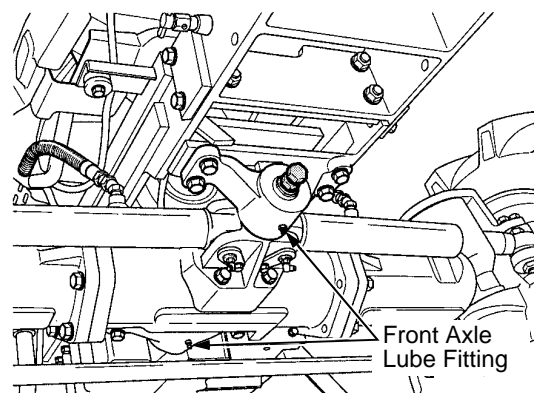

Figure 69

- Steering cylinders. See Figure 70.

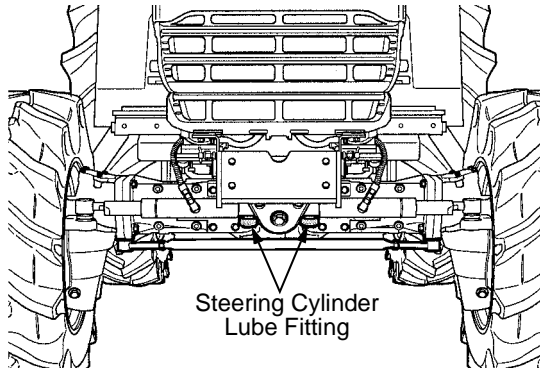

Figure 70

- 3 Point top link holder (each side). See Figure 72.

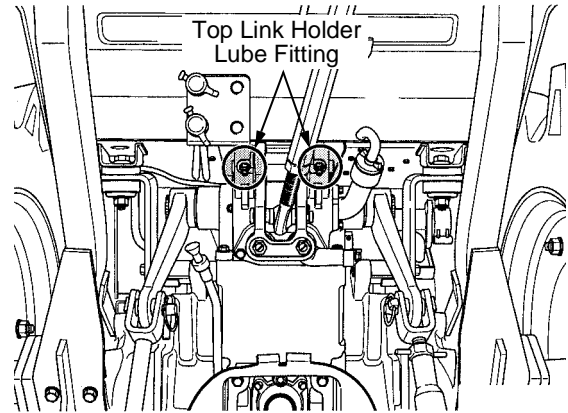

Figure 72

- Brake pedal shaft (both sides). See Figure 71.

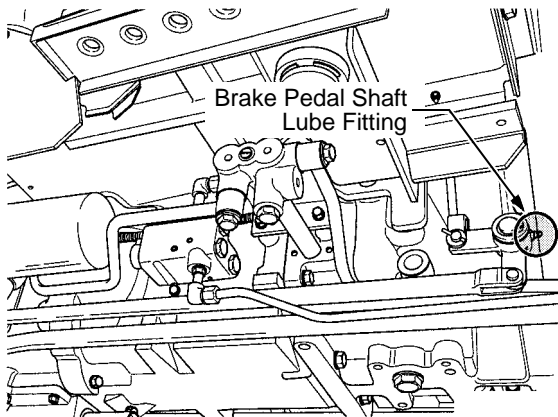

Figure 71

- Position lever support housing. See Figure 73.

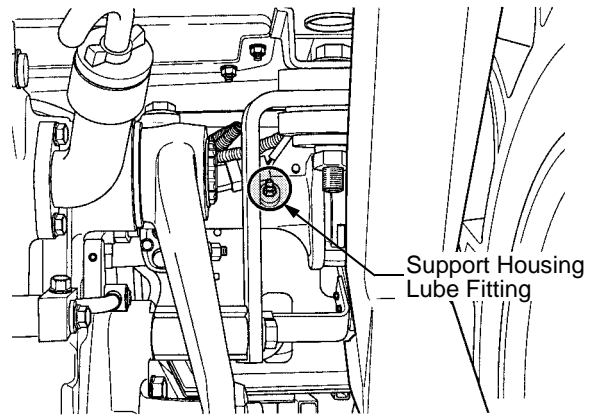

Figure 73

Periodically apply grease to both seat slides and to the threads of the right hand lift link to lubricate and prevent rust.

SERVICING THE BATTERY

General Battery Information



WARNING:

- Battery posts, terminals and related accessories contain lead and lead compounds. Wash hands after handling.
- Battery acid must be handled with great care, as contact with it can burn and blister the skin. It is advisable to wear protective clothing (goggles, rubber gloves and apron) when working with acid.
- Should battery acid accidentally splatter into the eyes or onto the skin, rinse the affected area immediately with clean cold water. If there is any further discomfort, seek prompt medical attention.
- If acid spills on clothing, first dilute it with clean water, then neutralize with a solution of ammonia/water or baking soda/water.
- Because battery acid is corrosive, do not pour it into any sink or drain. Before discarding an empty electrolyte container, rinse it thoroughly with a neutralizing solution.
- NEVER connect (or disconnect) battery charger clips to the battery while the charger is turned on, as it can cause sparks.
- Keep all sources of ignition (cigarettes, matches, lighters) away from the battery. The hydrogen gas generated during charging can be combustible.
- As a further precaution, only charge the battery in a well ventilated area.
- Always shield eyes and protect skin and clothing when working near batteries.



WARNING: Batteries contain sulfuric acid and may emit explosive gases. Use extreme caution when handling batteries. Keep batteries out of the reach of children.

Battery Removal



WARNING: Battery posts, terminals and related accessories contain lead and lead compounds. Wash hands after handling.

The battery is located at the front of the tractor behind the grill, just forward of the radiator.

To remove the battery:

- Open the grill as described previously.

- Remove the two nuts and the battery hold-down strap from the battery hold-down rods. See Figure 74.

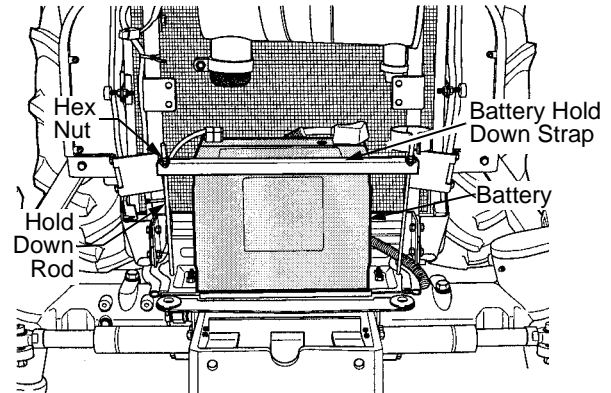

Figure 74

- Loosen the cable clamp of the negative battery lead, then lift the negative cable off the negative battery post. Move the cable away from the negative battery post.
- Repeat the above procedure to remove the cable from the positive battery post.
- Carefully lift the battery out of the tractor.

Install the battery by repeating the above steps in the reverse order.



WARNING: Always connect the positive lead to the battery before connecting the negative lead.

Battery Maintenance

- Check the battery occasionally to make certain it is tightly fixed in its battery tray.
- Make certain the battery vent caps are tightened securely in the vent holes.
- Spray the terminals and exposed wire with a battery terminal sealer, or coat the terminals with a thin coat of grease or petroleum jelly, to protect against corrosion.
- The battery should be kept clean. Any deposits of acid should be neutralized with baking soda and water. Be careful not to get this solution in the cells.



WARNING: Never remove any of the battery vent caps while the engine is running.

- Maintain the battery electrolyte level in each cell. Keep each cell filled to the bottom of the ring in each vent hole. Fill with distilled water if necessary. See Figure 75.

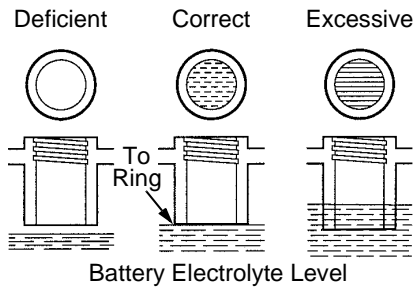

Figure 75

Re-charging the Battery

- Remove the vent caps from the battery. Check each cell and fill to the bottom of the ring in each vent hole with distilled water.
- Connect the positive lead from the charger to the positive battery terminal, then the negative lead to the negative terminal.
- Avoid quick charging as it may shorten the lifetime of the battery. Use a slow charge rate to charge the battery. The charging rate should be between 5 and 7 amps.
- Check the electrolyte level two hours after charging is completed and correct it, if necessary, by adding distilled water.

Battery Storage

- When storing the tractor for extended periods, disconnect the battery cables. Removing the battery from the unit is recommended.
- All batteries discharge during storage. Keep the exterior of the battery clean, especially the top. A dirty battery will discharge more rapidly.
- The battery must be stored with a full charge. As the battery discharges, the electrolyte is weakened and will freeze at a higher temperature.
- Recharge the battery every month in hot weather seasons or every two months in cold seasons.

SERVICING THE ELECTRICAL SYSTEM FUSES

Fuse Box



WARNING: Always replace blow fuses with fuses of the same rating. Using incorrect fuses could cause damage to the tractors wire harnesses. Never use a wire, coin, or any other conductive material to replace a fuse.

If one of the electrical circuits does not work, check the appropriate fuses first.

- Locate the fuse box on the lower left side of the pedestal near the clutch pedal. See Figure 76.

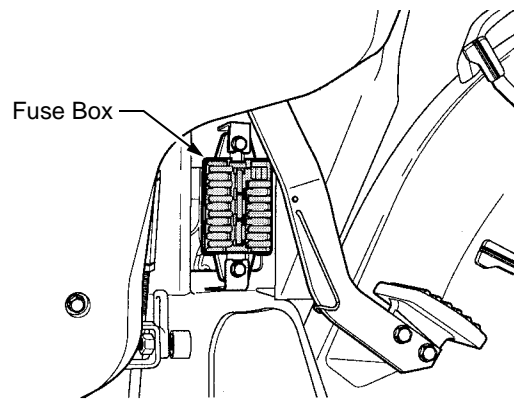

Figure 76

- Remove the cover from the fuse box.
- Carefully pull out the appropriate fuse(s) and check for a blown fuse. Replace with the same size fuse. See Figure 77 and Figure 78.

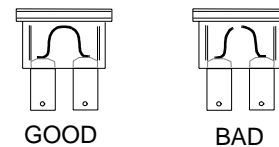

Figure 77

10A	10A	20A	20A	10A	20A
THE POWER OF TIMER RELAY	BACK-UP LAMP	WORKING LAMP	HEAD LAMP/ TAIL LAMP	P.T.O.	SPARE
10A	SPARE	20A	SPARE	25A	SPARE
10A	10A	10A	25A	10A	
SPARE	SPARE	STOP LAMP	TURN SIGNALS LAMP /TIMER RELAY	SPARE	
Use only the rating capacity fuse.					

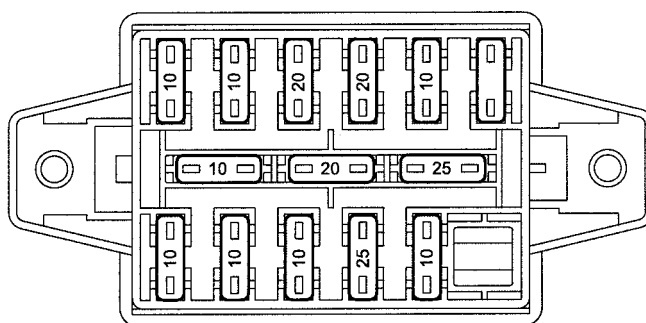

Figure 78

- If a fuse continually fails, have the electrical harnesses check by your Cub Cadet dealer or a qualified electrician.

Main Slow Blow Fuse

- Locate the slow blow fuse in the wire harness behind the left side panel. See Figure 79.

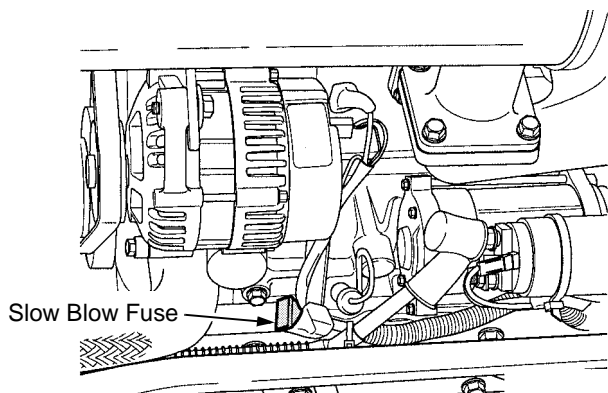

Figure 79

- Remove the coupling and replace the old slow blow fuse with a new one.

IMPORTANT: The slow blow fuse serves to protect the electrical system. If the fuse blows, have the tractor electrical system checked to find the cause. Never substitute a different fuse.

TIRE MAINTENANCE

Check the tire air pressure before each use. Keep the tires inflated to the recommended pressures. Improper inflation will shorten the service life of a tire. See the tire side wall, or the Tire Inflation chart, for proper inflation pressures.

Classification		Tire Size	Inflation Pressure
Ag	Front	9.5 x 16R1	20 psi
	Rear	14.9 x 24R1	20 psi
Indust.	Front	12 x 16.5	20 psi
	Rear	17.5 x 24	20 psi

- Do not inflate a tire above the maximum pressure shown either on the sidewall of the tire or the Tire Inflation chart.
- Do not reinflate a tire that has been run flat or seriously under inflated. Have a qualified tire mechanic inspect and service the tire.
- **WHEN SEATING THE BEADS, NEVER INFLATE A TIRE OVER 35 PSI.** If the tire beads have not seated at or before 35 PSI, allow the tire to deflate. Reposition the tire on the rim, lubricate the tire beads and rim flanges, and reinflate until seated - up to a maximum of 35 PSI. **Inflating a tire with unseated beads beyond 35 PSI could break the bead or rim with sufficient explosive force to cause a serious injury.**



WARNING: Servicing tires can be dangerous. Whenever possible, trained personnel should service and mount tires.

TRACTOR STORAGE

If the tractor will not be operated for two or three months or longer, perform the following measures before storing.

- Repair or replace worn or broken parts and tighten all fasteners.
- Change the engine oil and run the engine about five minutes to circulate oil throughout the engine block.
- Apply oil or grease to parts which may rust.
- Remove the additional weight if mounted.
- Inflate the tires to a little above the standard pressure.
- Drain the coolant from the radiator, flush the radiator, and refill with new coolant.
- Depress the clutch pedal and engage the clutch pedal lock. See Figure 80.

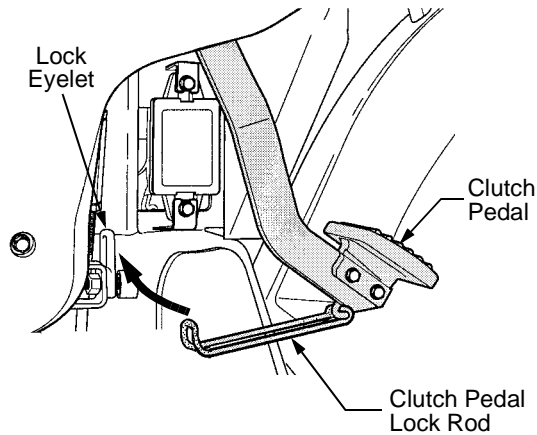

Figure 80

IMPORTANT: *If the tractor is stored for a long period with the clutch engaged, the clutch disc may rust and render the clutch inoperative.*

- Remove or lower any implements to the ground.
- Remove the battery from the tractor, recharge it, refill the electrolyte to the proper level, and store in a dry place out of direct sunlight. If the battery cannot be removed, disconnect the ground cable from the negative terminal of the battery.
- The battery discharges over time even while in storage. Recharge it once a month in hot seasons, and once every two months in cold seasons.
- Store the tractor where dry and sheltered from rain. Cover the tractor with a tarpaulin.
- Remove the drain plug and drain the clutch housing.
- Turn the fuel cock on the fuel filter to the off position.
- Clean the air cleaner dust cup and filter element.
- To decrease the weight on the tires and to protect the tires from the moisture of the ground, jack up the tractor and set blocks underneath the axles, or put wood boards beneath the tires.

SECTION 5: TROUBLESHOOTING

ENGINE TROUBLESHOOTING

When Engine is Difficult To Start

Cause	Countermeasures
Fuel is thick and doesn't flow	<ul style="list-style-type: none">- Check the fuel tank and fuel filter.- Remove water, dirt and other impurities.- Check the fuel filter element for water, dirt , or other impurities, and replace the filter if necessary.
Air or water mixed in fuel system	<ul style="list-style-type: none">- If air is in the fuel filter or injection lines, the fuel pump will not work properly. To attain proper fuel injection pressure, check carefully for loosened fuel cap nut, etc.- Loosen air vent screw over fuel filter and fuel injection pump to eliminate all the air in the fuel system.
Thick carbon deposits on orifice of injection nozzle	<ul style="list-style-type: none">- This is caused when water or dirt is mixed in the fuel. Clean the nozzle injection piece, being careful not to damage the orifice.- Check to see if nozzle is working properly. If not, install a new nozzle.
Valve clearance is wrong	<ul style="list-style-type: none">- Adjust valve clearance: Intake — 0.0098 in. (0.25mm) Exhaust — 0.0118 in. (0.3mm)
Leaking valves	<ul style="list-style-type: none">- Grind valve
Fuel injection timing is wrong	<ul style="list-style-type: none">- Adjust injection timing.- The injection timing is 18° before top dead center.
Engine oil becomes thick in cold weather and engine cranks slowly.	<ul style="list-style-type: none">- Change grade of oil according to the weather (ambient temperature).
Low compression	<ul style="list-style-type: none">- Bad valve or excessive wear of rings, pistons and liners cause insufficient compression. Replace with new parts.
Battery is discharged and the engine will not crank	<ul style="list-style-type: none">- Charge battery.- In the winter, always remove battery from tractor, fully charge, and keep indoors. Install in tractor at time of use.

When Output Is Insufficient

Cause	Countermeasures
Carbon build-up around orifice of nozzle piece	<ul style="list-style-type: none"> - Clean orifice and needle valve, while being very careful not to damage the nozzle orifice. - Check nozzle. If defective, replace with new parts.
Compression is insufficient	<ul style="list-style-type: none"> - Bad valve and excessive wear of rings, pistons, and liners cause insufficient compression. Replace with new parts. - Grind valves.
Overheating of moving parts	<ul style="list-style-type: none"> - Check engine lubrication system. - Check to see if lube oil filter is working properly. - Filter screens or elements deposited with impurities would cause poor lubrication. Clean Screens. - Check to see if bearing clearances are within factory specifications. - Check engine timing. Adjust timing to 18° before top dead center.
Valve out of adjustment	<ul style="list-style-type: none"> - Adjust to proper valve clearance: Intake — 0.0098 in. (0.25mm) Exhaust — 0.0118 in. (0.3mm)
Air cleaner is dirty	<ul style="list-style-type: none"> - Clean the element and dust cup weekly, and replace element after every 100 hours of operation.
Fuel injection pressure is wrong	<ul style="list-style-type: none"> - Adjust to proper pressure of 2.000 psi (140 kgf/cm² - 13.7 KPa).
Injection pump wear	<ul style="list-style-type: none"> - Do not use poor quality fuel because it will cause wear of the the pump. Only use No. 2 diesel fuel. - Check the fuel injection pump element and delivery valve assembly and replace as necessary.

When Color of Exhaust Is Especially Bad

See your Cub Cadet dealer.

Cause	Countermeasures
Fuel governing device is bad	<ul style="list-style-type: none"> - Contact your dealer for repairs.
Fuel is of extremely poor quality	<ul style="list-style-type: none"> - Select good quality fuel: Above 14°F (-10°C) — No. 2 Diesel fuel Below 14°F (-10°C) — No. 1 Diesel fuel
Nozzle is bad	<ul style="list-style-type: none"> - If necessary, replace with new nozzle.
Combustion is incomplete	<ul style="list-style-type: none"> - Cause is poor atomization, improper injection timing, etc. because of trouble in the injection system, or because of poor valve adjustment, compression leakage, poor compression, etc. Check for the cause and repair.

When Engine Suddenly Stops

Cause	Countermeasures
Fuel Leakage	<ul style="list-style-type: none"> - Check the fuel tank and refill if necessary. - Check fuel system for air or leaks.
Bad Nozzle	<ul style="list-style-type: none"> - If necessary, replace with a new nozzle.
Moving parts are overheated due to shortage of lubricating oil or improper lubrication	<ul style="list-style-type: none"> - Check amount of engine oil with the oil level gauge. - Check lubricating oil system. - Check to see if oil filter element has become clogged. If necessary, replace with a new oil filter. - Check to see if the engine bearing clearances are within factory specifications.

IMPORTANT: *When the engine has suddenly stopped, allow the engine to decompress; then try to turn the engine over by lightly pulling on the fan belt. If the engine turns easily without any abnormal resistance, the cause of the trouble is usually lack of fuel or a bad nozzle.*

When the Engine Must Be Stopped Immediately

Cause	Countermeasures
Speed suddenly decrease or increases	<ul style="list-style-type: none"> - Check the adjustments and timing of the injection pump and the fuel system.
Unusual sound is heard suddenly	<ul style="list-style-type: none"> - Check all moving parts carefully.
Color of exhaust suddenly turns dark	<ul style="list-style-type: none"> - Check the fuel injection system, especially the fuel injection nozzle.
Bearing parts are overheated	<ul style="list-style-type: none"> - Check the lubricating system.
Oil lamp lights up during operation	<ul style="list-style-type: none"> - Check the lubricating system. - Check to see if the engine bearing clearances are within factory specifications. - Check the function of the oil regulating valve. - Check the oil pressure switch. - Check filter base gasket.

TRACTOR TROUBLESHOOTING

When Tractor Does Not Move While Engine Is Running

Cause	Countermeasures
Speed change lever is in neutral	<ul style="list-style-type: none"> - Check position of shift levers.
Parking brake is engaged	<ul style="list-style-type: none"> - Release the parking brake.

When 3 Point Hitch Does Not Move

Cause	Countermeasures
Oil filter is clogged	<ul style="list-style-type: none"> - Change the oil filter.
3 point hitch does not lower	<ul style="list-style-type: none"> - Check the hydraulic adjusting grip.

BATTERY TROUBLESHOOTING

Condition of Battery	Cause	Countermeasures	Cause
Starter does not function	<ul style="list-style-type: none"> - Key is not "ON". - Battery is over-used until light becomes dim. - Defective alternator or rectifier preventing charging of the battery. - Dirty or corroded terminal contacts. - Bad brushes, armature or field in alternator. - Life of battery expired. 	<ul style="list-style-type: none"> - Turn key "ON" - Charge for a long period at the normal charging rate until specific gravity of 1.26 is reached. - Repair alternator and replace defective rectifier, and fully charge the battery. - Wash terminal with hot water and tighten well. - Replace. - Replace battery. 	<ul style="list-style-type: none"> - Do not overuse the battery and charge before being fully discharged. - Check alternator/rectifier. - Keep terminals clean and well tightened. Coat terminals with grease to prevent corrosion.
Low electrolyte level	<ul style="list-style-type: none"> - Battery used with shortage of electrolyte. - Battery over-used. Charging was neglected. (Refrain from over-discharging) - Defective alternator/rectifier, defective terminal contacts causing corrosion of electrodes. 	<ul style="list-style-type: none"> - Add distilled water and charge battery. - Charge for a long period at the normal charging rate. - Check alternator and rectifier, and charge for a long period at the normal charging rate. 	<ul style="list-style-type: none"> - Make routine checks of electrolyte. - Do not overuse the battery and charge before being fully discharged. - Make routine checks of terminals to make sure they are clean and tight
Battery cannot be charged	<ul style="list-style-type: none"> - The current of the alternator during operation is too high, causing plates to drop, warp, or short circuit. - Life of battery expired 	<ul style="list-style-type: none"> - Decrease the charging current of alternator. - Replaced damaged battery. - Exchange battery. 	<ul style="list-style-type: none"> - Check charging current at alternator.
Corrosion of terminals is severe	<ul style="list-style-type: none"> - Current of the alternator during operation is too high. 	<ul style="list-style-type: none"> - Clean corrosion from terminals and tighten well. - Adjust charging current of alternator. 	<ul style="list-style-type: none"> - Keep terminals clean and well tightened. - Apply a coat of grease to terminals to prevent corrosion. - Check charging current of alternator.
Electrolyte decreases rapidly	<ul style="list-style-type: none"> - Over heating due to over charging. - Battery cracked or has small holes. 	<ul style="list-style-type: none"> - Check charging output. - Replace battery. 	<ul style="list-style-type: none"> - Secure battery in tractor so it cannot move.

SECTION 6: SPECIFICATIONS

Model 8454			
Maximum PTO Power		38.0 PS	
Engine GROSS Power		45.0 HP	
Engine	Model		4A220
	Type		Indirect injection, water cooled, 4-cycle diesel
	Number of cylinders		4
	Bore and Stroke		3.425 x 3.638 Inches (87 x 92.4 mm)
	Total displacement		134.0 cu. in (2,197 cc)
	Rated revolutions		2600 RPM
	Injection timing		18° before T.D.C.
	Injection order		1-3-4-2
	Compression ratio		22:1
	Lubrication system		Forced Lubrication
	Cooling system		Pressurized radiator, forced circulation with water pump
	Alternator		12V, 50 amps
	Weight (Dry)		456 Lbs. (207 kg)
Capacities	Fuel tank		11.5 Gal. (43.7 L.)
	Engine crankcase		1.9 Gal. (7.0 L.)
	Engine coolant		2.4 Gal. (8.9 L.)
	Transmission case		9.0 Gal. (34 L.)
	Front axle case		2.2 Gal. (8.2 L.)
Dimensions (with std. tires)	Overall length (without 3 pt.)		120.9 in.
	Overall length (with 3 pt.)		130.8 in.
	Overall width (max. w/ Ag tires)		61.0 in.
	Overall height (Top of ROPS)		94.3 in.
	Overall height (Top of steering wheel)		63.3 in.
	Wheelbase		71.6 in.
	Ground Clearance		14.5 in.
	Tread width with std. tires	Front	49.8 in.
	Rear	46.4 - 58.6 in.	
Traveling system	Clutch		Dry single stage
	Steering		Hydrostatic steering system
	Transmission		Synchronized shuttle and transmission 12 forward and 12 reverse speeds
	Brake	Traveling	Wet disc type
		Parking	Connected to traveling brake
Differential		Bevel gear	
Hydraulic system	Hydraulic lift control system		Position, Draft, and Mixed control
	Pump capacity	Main pump	8.2 gal./min. (31.2 L/min.)
		Power strng.	5.0 gal./min. (18.7 L/min.)
	Three point hitch		SAE Category 1
Maximum lifting capacity (at hitch lift point)		2314 lbs. (1041 kg)	

SPECIFICATIONS

Model 8454			
PTO	No. or Remote control valve ports		2 (4 optional)
	PTO HP		38.0
	PTO shaft		SAE 1-3/8 in., 6 splines
	Revolutions	Rear PTO	540 (@ 2,451 rpm)
Minimum turning radius (with brake)			112.7 in. (2,865 mm)
Traction system			Swing drawbar
Weight (with ROPS)			3792 lbs.
Approx. Speed (@2600 rpm w/Std. tires)	Forward	Low range	0.2 - 0.7 mph (0.4 - 1.2 kph)
		Medium Range	1.1 - 3.6 mph (1.7 - 5.8 kph)
		High range	4.6 - 15.3 mph (7.4 - 24.6 kph)
	Reverse	Low range	0.2 - 0.6 mph (0.3 - 1.0 kph)
		Medium Range	0.9 - 3.0 mph (1.4 - 4.8 kph)
		High range	3.8 - 12.7 mph (6.1 - 20.4 kph)
Tires	Ag	Front	9.5" - 16"
		Rear	14.9" - 24"
	Industrial	Front	12" x 16.5"
		Rear	17.5" x 24"



**LIMITED WARRANTY
FOR CUB CADET COMPACT TRACTORS
AND CUB CADET ATTACHMENTS**

Proper maintenance of your Cub Cadet equipment is the owner's responsibility. Follow the instructions in your operator's manual for correct lubricants and maintenance schedule. Your Cub Cadet dealer carries a complete line of genuine Cub Cadet parts and quality lubricants and filters for your equipment's engine, transmission, chassis and attachments.

This limited warranty covers any defect in materials or workmanship in your Cub Cadet compact tractor and Cub Cadet attachments from the date of purchase for the *first user purchaser*.

COMPACT TRACTOR	TWO YEARS OR 1500 HOURS (whichever comes first)
ENGINE AND DRIVE LINE	THREE YEARS OR 2000 HOURS (whichever comes first) — PARTS ONLY
BATTERY	ONE YEAR PRORATED WITH 100% REPLACEMENT DURING THE FIRST 3 MONTHS
CUB CADET ATTACHMENTS	ONE YEAR

The ENGINE AND DRIVE LINE is defined as, and is limited to:

ENGINE: Includes the Crankcase, Cylinder Head, Front Gear Case, Valve Cover Pans, and all parts contained therein.

DRIVE LINE: Includes the Clutch Housing, Transmission Case, Differential and Final Drive Housing, and all parts contained therein; plus Drive Axles, and Mid and Rear PTO Output Shafts.

We will replace or repair any part or parts without charge through your Authorized Cub Cadet Compact Tractor Dealer.

CUB CADET shall not be liable for incidental or consequential loss or damages including, without limitation, loss of use, loss of profit, loss of or damage to crops, inconvenience, commercial loss, or any other incidental or consequential damages whatsoever.

ITEMS NOT COVERED

The warranty does not cover routine maintenance items such as lubricants, filters (oil, fuel, air and hydraulic), cleaning, tune-ups, brake and/or clutch inspection, adjustments made as part of normal maintenance, blade sharpening, set-up, abuse, accident and normal wear. It does not cover incidental costs such as transporting your equipment to and from the dealer, telephone charges or renting a product temporarily to replace a warranted product. Specific items not covered are: lamp bulbs, injection nozzles, fuel injection pumps, glow plugs, strainers, fuses, brake linings, clutch facings, clutch discs, coolant, rubber products, glass products, plastic products, packings, belts and damage caused by use in an application for which the product is not designed, or any other misuse, neglect, incorporation or use of unsuitable attachments or parts, unauthorized alteration, improper installation, or any causes other than defects in material or workmanship of the product.

There is no other express warranty.

HOW TO OBTAIN SERVICE

Contact your authorized Cub Cadet servicing dealer who sold you your Cub Cadet equipment. If this dealer is not available, see the Consumer Yellow Pages under "lawn mowers" for the name of a dealer near you.

If you need further assistance in finding an authorized Cub Cadet servicing dealer, contact:

**CUB CADET LLC
POST OFFICE BOX 361131
CLEVELAND, OHIO 44136-0019**

HOW DOES STATE LAW APPLY?

This limited warranty gives you specific legal rights, and you may also have other rights which vary from state to state.

CHANGES

Cub Cadet LLC reserves the right to make changes in the design and other changes in its products at any time without notice and without incurring any obligation to product previously manufactured or purchased.