

Cub Cadet

Operator's Manual



SERIES 5000

TRACTOR

MODEL 5252

IMPORTANT: READ SAFETY RULES AND INSTRUCTIONS CAREFULLY

Warning: This unit is equipped with an internal combustion engine and should not be used on or near any unimproved forest-covered, brush-covered or grass-covered land unless the engine's exhaust system is equipped with a spark arrester meeting applicable local or state laws (if any). If a spark arrester is used, it should be maintained in effective working order by the operator. In the State of California the above is required by law (Section 4442 of the California Public Resources Code). Other states may have similar laws. Federal laws apply on federal lands. A spark arrester for the muffler is available through your nearest engine authorized service dealer or contact the service department, P.O. Box 361131 Cleveland, Ohio 44136-0019.

CUB CADET LLC P.O. BOX 361131 CLEVELAND, OHIO 44136-0019 [www.cubcadet.com]

PRINTED IN U.S.A.

FORM NO. 769-00867F

(5/05)

TABLE OF CONTENTS

TO THE OWNER	2
CALLING SERVICE INFORMATION	2
RECORDING MODEL AND SERIAL NUMBER INFORMATION	3
IMPORTANT SAFE OPERATION PRACTICES	4
SAFETY LABELS	8
SECTION 1: CONTROLS AND FEATURES	9
SECTION 2: OPERATION	14
SECTION 3: ADJUSTMENTS	23
SECTION 4: TRACTOR MAINTENANCE	26
SECTION 5: ENGINE INFORMATION AND MAINTENANCE	38
SECTION 6: SPECIFICATIONS	43
SECTION 7: OPTIONAL EQUIPMENT AND ACCESSORIES	45
WARRANTY	48

TO THE OWNER

This Operator's Manual is an important part of your new tractor. The information contained in this manual has been prepared in detail to help you better understand the features, correct operation, adjustments, and maintenance of your tractor. The performance and dependability of this tractor rely greatly on the manner in which it is operated and maintained. Therefore, it is recommended that all operators of the tractor carefully read this manual and fully understand its operation. Also keep the manual available for reference to ensure proper operation, and that maintenance procedures are performed as scheduled to assure the tractor's optimal mechanical condition.

NOTE: *All references to LEFT, RIGHT, FRONT, and REAR, unless specifically stated otherwise, indicate that relative position on the tractor when facing forward while seated in the operator's seat.*

Your authorized *Cub Cadet* dealer is interested in the performance you receive from your tractor, and with the maintenance needed to ensure the satisfactory operation of your tractor. The dealer has trained service personnel familiar with the latest servicing information, is equipped with the latest tools, and has a complete line of genuine *Cub Cadet* service parts which assure proper fit and high quality.

CALLING SERVICE INFORMATION

The engine manufacturer is responsible for all engine-related issues with regards to performance, power-rating, and specifications.

If you have difficulties with the tractor and/or equipment; have any questions regarding the operation or maintenance of this equipment; or desire additional information not found in this manual, contact your dealer. If you need assistance in locating a dealer in your area, contact the Customer Dealer Referral Line by calling:

1-877-282-8684

Or you may contact Cub Cadet via the internet by logging on to our Web Site at:

www.cubcadet.com

Before contacting your dealer or Cub Cadet, make sure that you have your model number(s) and manufacturing date(s) available.

RECORDING MODEL AND SERIAL NUMBER INFORMATION

Product identification plates are provided for major components of your tractor. The numbers on these plates are important if your tractor should require dealer service, or if you need additional information on your tractor. Prior to using your tractor for the first time, record the numbers from the identification plates in the appropriate spaces provided below.

- The tractor model plate is located on the right frame rail behind the right front tire.
- The engine information plate is located on the side of the blower housing at the front of the engine.
- The transmission serial plate is located on the rear of the transmission, below the PTO shaft.
- The ROPS information plate is located on a vertical leg of the ROPS.

Tractor Model Plate:

 Model Number

 Mfg. Date (Serial No.)

Engine Information:

 Model No.

 Displacement

 Spec. No.

 Serial No.

Transmission Serial Plate:

 Serial Number

ROPS Information Plate:

 ROPS Serial No.

TRACTOR MODEL PLATE

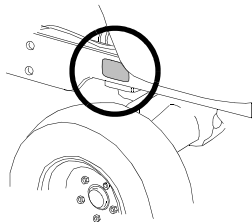
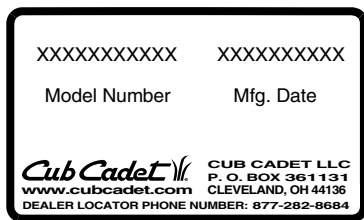

TRANSMISSION SERIAL PLATE

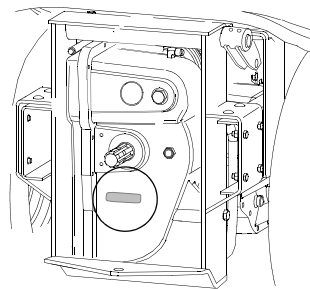

ROPS INFORMATION PLATE

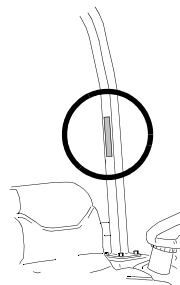

IMPORTANT SAFE OPERATION PRACTICES



WARNING: THIS SYMBOL POINTS OUT IMPORTANT SAFETY INSTRUCTIONS WHICH, IF NOT FOLLOWED, COULD ENDANGER THE PERSONAL SAFETY AND/OR PROPERTY OF YOURSELF AND OTHERS. READ AND FOLLOW ALL INSTRUCTIONS IN THIS MANUAL BEFORE ATTEMPTING TO OPERATE YOUR UNIT. FAILURE TO COMPLY WITH THESE INSTRUCTIONS MAY RESULT IN PERSONAL INJURY. WHEN YOU SEE THIS SYMBOL, HEED ITS WARNING.



WARNING: The engine exhaust, some of its constituents, and certain vehicle components contain or emit chemicals known to the State of California to cause cancer, birth defects or other reproductive harm.



DANGER: Your tractor was built to be operated according to the rules for safe operation in this manual. As with any type of power equipment, carelessness or error on the part of the operator can result in serious injury. To help prevent accidents, read and take the following precautions before operating this tractor. Failure to observe the following safety instructions could result in serious injury or death.

1. GENERAL OPERATION

- Read, understand, and follow all instructions in the operator's manual and on the machine before starting. Keep this manual in a safe place for future and regular reference.
- Only allow responsible individuals familiar with the instructions to operate the machine. All operators should evaluate their ability to operate the tractor safely enough to protect themselves and others from serious injury. Know controls and how to stop the machine quickly.
- Do not put hands or feet under the cutting deck or near rotating parts.
- Clear the area of objects such as rocks, toys, wire, etc. which could be picked up and thrown by the blades. A small object may have been overlooked and could be accidentally thrown by the mower in any direction and cause injury to you or a bystander. To help avoid a thrown objects injury, keep children, animals, bystanders and helpers at least 75 feet from the mower while it is in operation. Always wear safety glasses with side shields or safety goggles during operation or while performing an adjustment or repair, to protect eyes from foreign objects. Stop the blades when crossing gravel drives, walks or roads.
- Be sure the area is clear of other people before mowing. Stop machine if anyone enters the area.
- Never carry passengers.
- Use extreme caution when shifting into reverse and backing up. Always look down and behind before and while backing.
- Be aware of the mower and attachment discharge direction and do not point it at anyone. Do not operate the mower without either the entire grass catcher or the chute guard in place.
- Slow down before turning. Operate the machine smoothly. Avoid erratic operation and excessive speed.
- Never leave a running machine unattended. Always turn off the blades, place the transmission in neutral, set the parking brake, stop the engine and remove key before dismounting.
- Turn off blades when not mowing.
- Stop the engine and wait until the blades come to a complete stop before (a) removing the grass catcher or unclogging chute, or (b) making any repairs, adjusting or removing any grass or debris.
- Mow only in daylight or good artificial light.
- Do not operate the machine while under the influence of alcohol or drugs.
- Use extra care when loading or unloading the machine into a trailer or truck because the unit could tip over causing serious personal injury.
- Never make a cutting height adjustment while the engine is running if the operator must dismount to do so.
- Wear sturdy, rough-soled work shoes and close-fitting slacks and shirts. Do not wear loose fitting clothes or jewelry. They can be caught in moving parts. Never operate a unit in bare feet, sandals or sneakers.

- Disengage all attachment clutches, thoroughly depress the brake pedal and shift into neutral before attempting to start the engine.
- Your mower is designed to cut normal residential grass of a height no more than 10". Do not attempt to mow through unusually tall, dry grass (e.g. pasture) or piles of dry leaves. Debris may build up on the mower deck or contact the engine exhaust presenting a potential fire hazard.
- Use only accessories approved for this machine by *Cub Cadet*. Read, understand and follow all instructions provided with the approved accessory.
- Use the roll bar and seat belt for safe operation. Overturning the tractor without a roll bar, or with a roll bar and the seat belt unfastened, can result in death or injury.
- Always use the seat belt, except when the roll bar is in the folded position, or if the roll bar has been removed.
- Use the handholds and running boards when getting on and off the tractor to help prevent accidental falls. Keep the running boards clear of mud and debris.
- Keep all safety decals clean and readable. Replace any missing, illegible, or damaged safety decals.
- Always sit in the tractor seat when starting the engine or operating controls. Do not start the engine or operate controls while standing beside the tractor.
- Never tamper with safety devices. Check their proper operation regularly. Contact your Cub Cadet dealer if safety devices malfunction.
- Avoid accidental contact with control pedals while the engine is running, as this can cause unexpected movement of the tractor.
- Pull only from a drawbar or the lower hitch links in the down position. Make certain the drawbar pin is locked in place. Pulling from the rear axle of the tractor or any point above the axle could cause the tractor to overturn.
- Maintain the weight balance of the tractor. Install front end weights to counterbalance heavy implements attached to the three point hitch. Do not operate the tractor with a light front end.
- Do not leave equipment in the raised position.
- Watch for traffic when operating near or crossing roadways. If local laws permit road travel, use the flashing hazard lights and SMV signs when traveling on public roadways.
- Make certain all tractor lights are illuminated when operating at night.

- Check overhead clearance carefully before driving under power lines, wires, bridges or low hanging tree branches, before entering or leaving buildings, or in any other situation where the operator and/or roll bar may be struck, which could result in serious injury.
- If the tractor becomes stuck, use reverse to free the tractor to prevent tractor upset.

2. SLOPE OPERATION

Slopes are a major factor related to loss of control and tip-over accidents which can result in severe injury or death. All slopes require extra caution. If you cannot back up the slope or if you feel uneasy on it, do not operate this unit on that area or serious injury could result.

Do not operate on inclines with a slope in excess of 15 degrees (a rise of approximately 2-1/2 feet every 10 feet). The tractor could overturn and cause serious injury

DO:

- Operate up and down slopes, not across.
- Remove obstacles such as rocks, limbs, etc.
- Watch for holes, ruts or bumps. Uneven terrain could overturn the machine. Tall grass can hide such obstacles.
- Place the transmission in the low range. when climbing or descending slopes. Always keep machine in gear when going down slopes to take advantage of engine braking action.
- Follow the manufacturers recommendations for counterweights to improve stability.
- Keep all movement on the slopes slow and gradual. Do not make sudden changes in speed or direction. Rapid engagement or braking could cause the front of the machine to lift and rapidly flip over backwards which could cause serious injury.
- Avoid starting or stopping on a slope. If tires lose traction, disengage the PTO and proceed slowly straight down the slope.

DO NOT:

- Do not turn on slopes unless necessary; then, turn slowly and gradually downhill, if possible.
- Do not mow near drop-offs, ditches or embankments. The mower could suddenly turn over if a wheel goes over the edge of a cliff or ditch, or if an edge caves in.
- **Do not** mow on wet grass. Reduced traction could cause sliding.
- **Do not** try to stabilize the machine by putting your foot on the ground.

3. CHILDREN

- Tragic accidents can occur if the operator is not alert to the presence of children. Children are often attracted to the machine. Never assume children will remain where you last saw them.
- Keep children out of the mowing area and in watchful care of an adult other than the operator.
- To avoid back-over accidents, always disengage the cutting blades before shifting in reverse. The "PTO Reverse Override Switch" should not be used when children or others are around.
- Be alert and turn machine off if children enter the area.
- Before and when backing, look behind and down for small children.
- Never carry children, even with the blades off. They may fall off and be seriously injured or interfere with safe machine operation.
- Never allow children under 14 years old to operate the machine. Children 14 years and over should only operate machine under close parental supervision and proper instruction.
- Use extra care when approaching blind corners, shrubs, trees or other objects that may obscure your vision of a child or other hazard.
- Remove key when machine is unattended to prevent unauthorized operation.

4. OPERATING THE PTO

- When operating PTO driven equipment, disengage the PTO, stop the engine, and wait until the PTO stops before dismounting the tractor and disconnecting the equipment.
- Do not wear loose fitting clothing when operating the PTO or when near rotating equipment.
- To prevent injury, do not adjust, unclog, clean, or service PTO driven equipment while the tractor engine is running.
- Make certain all PTO shields are always installed.

5. SAFETY FRAME (ROPS)

Your tractor is equipped with a rollover protective structure (ROPS) which must be maintained in a fully functional condition. Use care when driving through doorways or spaces with a low overhead.

- Never modify the ROPS in any way.

- Never attempt to straighten or reweld any part of the main frame or retaining brackets that have been damaged. Doing so may weaken the structure and endanger your safety.
- Never secure any parts on the main frame or attach the safety frame with anything other than the special fasteners specified.
- Never attach ropes, chains, or cables to the ROPS for pulling purposes.
- Although the ROPS provides you the maximum protection possible, never take unnecessary risks.

6. SERVICE

- Use extreme care in handling gasoline and other fuels. They are extremely flammable and the vapors are explosive. Use only an approved container.
 - a. Use only an approved container.
 - b. Never remove fuel cap or add fuel with the engine running. Allow the engine to cool at least two minutes before refueling.
 - c. Replace the fuel cap securely and wipe off any spilled fuel before starting the engine as it may cause a fire or explosion.
 - d. Extinguish all cigarettes, cigars, pipes and other sources of ignition.
 - e. Never refuel the machine indoors because fuel vapors will accumulate in the area.
 - f. Never store the fuel container or machine inside where there is an open flame or spark, such as a gas hot water heater, space heater or furnace.
- Escaping hydraulic fluid under pressure can penetrate the skin. If fluid is injected into the skin, seek immediate medical attention. Do not use your hand to check for leaks. Use a piece of cardboard or paper.
- Never run a machine inside a closed area.
- To reduce fire hazard, keep the tractor free of any debris build-up. Clean up oil or fuel spillage.
- Before cleaning, repairing or inspecting, make certain the blades and all moving parts have stopped.
- Check the blade fasteners at frequent intervals for proper tightness. Also visually inspect blades for damage (e.g., excessive wear, bent, cracked). Replace with blades which meet original equipment specifications.

- Keep all nuts, bolts and screws tight to be sure the equipment is in safe working condition.
- Never tamper with safety devices. Check their proper operation regularly.
- After striking a foreign object, stop the engine, and thoroughly inspect the mower for any damage. Repair the damage before restarting and operating the mower.
- Mower blades are sharp and can cut. Wrap the blades or wear gloves, and use extra caution when servicing blades.
- Check brake operation frequently. Adjust and service as required.
- Engine components become hot during operation and can cause a burn. Allow to cool down before touching.
- Do not change the engine governor settings or overspeed the engine. Excessive engine speeds are dangerous.
- Observe proper disposal laws and regulations. Improper disposal of fluids and materials can harm the environment and the ecology.
- Prior to disposal, determine the proper method to dispose of waste from your local Environmental Protection Agency. Recycling centers are established to properly dispose of materials in an environmentally safe fashion.
- Use proper containers when draining fluids. Do not use food or beverage containers that may mislead someone into drinking from them. Properly dispose of the containers immediately following the draining of fluids.
- DO NOT pour oil or other fluids into the ground, down a drain or into a stream, pond, lake or other body of water. Observe Environmental Protection Agency regulations when disposing of oil, fuel, coolant, brake fluid, filters, batteries, tires and other harmful waste.
- We do not recommend the use of a pressure washer or garden hose to clean your unit. They may cause damage to electrical components; spindles; pulleys; bearings; or the engine. The use of water will result in shortened life and reduce serviceability.



WARNING: - YOUR RESPONSIBILITY: Restrict the use of this power machine to persons who read, understand and follow the warnings and instructions in this manual and on the machine.

SAFETY LABELS



INSTRUCTION / WARNING LABEL ON LEFT RUNNING BOARD

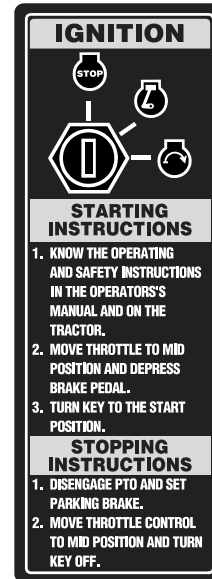

INSTRUCTION LABEL ON RIGHT RUNNING BOARD



PTO WARNING LABEL LOCATED ON REAR PTO SHIELD

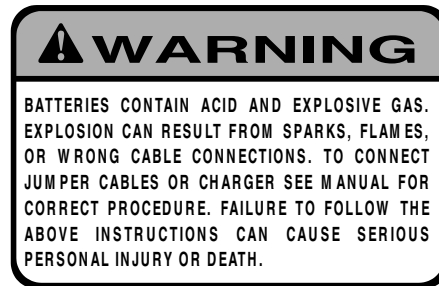

BATTERY WARNING LABEL LOCATED UNDER HOOD

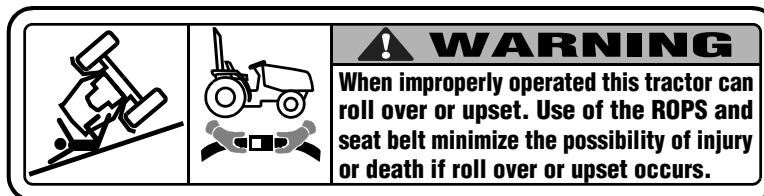

ROLL OVER WARNING LABEL LOCATED ON RIGHT/REAR FENDER

SECTION 1: CONTROLS AND FEATURES

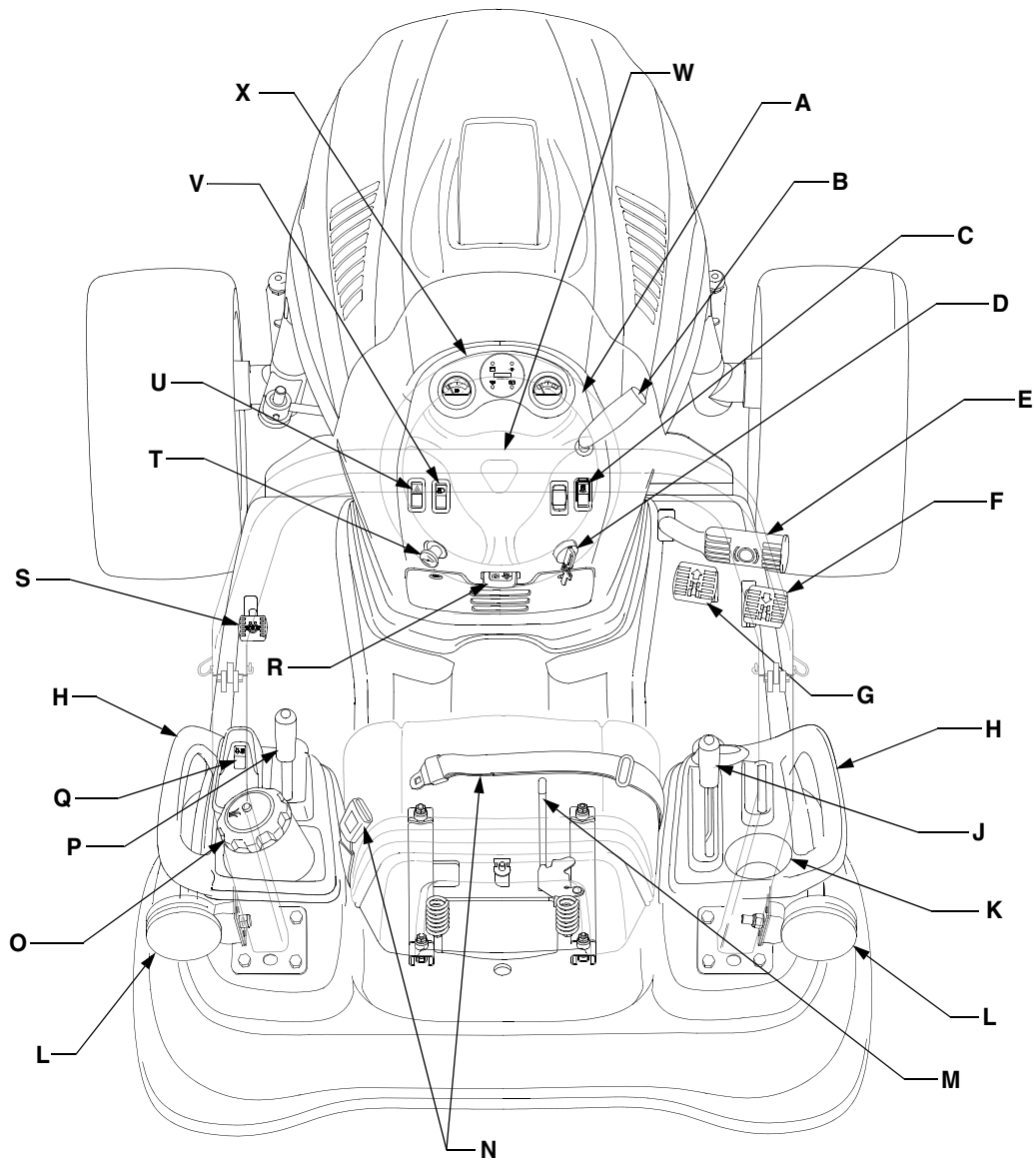

Figure 1

- | | | |
|--------------------|-----------------------------|--------------------------------|
| A. Steering Wheel | H. Hand Holds | Q. PTO Reverse Override Switch |
| B. Throttle Handle | J. Hydraulic Lift Lever | R. Parking Brake Lever |
| C. PTO Switch | K. Cup Holder | S. Differential Lock Pedal |
| D. Ignition Switch | L. Amber Hazard Light | T. Choke Control Knob |
| E. Brake Pedal | M. Seat Adjustment Lever | U. Hazard Light Switch |
| F. Reverse Pedal | N. Seat Belt | V. Headlight Switch |
| G. Forward Pedal | O. Fuel Fill Cap | W. Foldable ROPS |
| | P. Trans. Hi/Lo Shift Lever | X. Instrument Panel |

* Steering Wheel, Seat, and ROPS Transparent for Clarity

NOTE: References to *LEFT* and *RIGHT* indicate that side of the tractor when facing forward while seated in the drivers seat. Reference to *FRONT* indicates the grille end of the tractor; to *REAR*, the tow plate end.

A. Steering Wheel

The steering wheel is centered on the dash panel, and used to change the direction (left or right) of the tractor while driving.

NOTE: This tractor is equipped with hydraulic power steering. With this feature, the cap and spokes of the steering wheel may change position.

B. Throttle Handle

 This symbol indicates the fast position.

 This symbol indicates the slow position.

The throttle handle is located to the right of the steering wheel on the dash panel. When set in a given position, a uniform engine speed will be maintained. Rotate the handle rearward to increase the engine speed.

C. PTO Switch

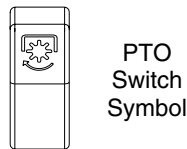

Figure 2

The PTO switch is a rocker type switch located to the right of the steering wheel on the dash panel. Push the *top* of the PTO switch downward to engage the PTO. Push the *bottom* of the switch downward to disengage.

D. Ignition Switch

NOTE: To prevent accidental starting and/or battery discharge, remove the key from the ignition switch when the tractor is not in use.

The ignition switch has three positions as follows:

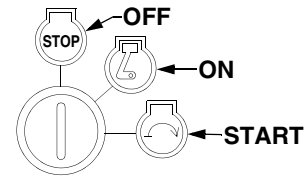

Figure 3

OFF - The engine and electrical system is turned off.

ON - The tractor electrical system is energized.

START - The starter motor will turn over the engine. Release the key immediately when the engine starts

E. Brake Pedal

Brake Pedal Symbol



Figure 4

The brake pedal is located at the front of the right running board above the forward and reverse pedals. Depress to engage the tractor brakes and neutralize the hydrostatic transmission. Fully depress the brake pedal to activate the safety interlock switch when starting the tractor.

F. Reverse Pedal

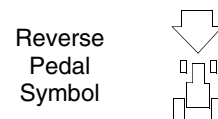

Figure 5

The reverse control pedal is located on the right running board below the brake pedal. Press the pedal down to move in reverse.



WARNING: Check behind the tractor to be sure the area is clear of people or obstacles. Use a slower speed to maintain control of the tractor when traveling in reverse.

G. Forward Pedal

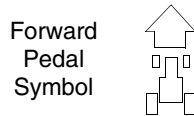

Figure 6

The forward control pedal is located on the right running board below the brake pedal. Slowly press down on the pedal to start moving forward. The forward ground speed of the tractor is directly affected by the distance the pedal is depressed.

H. Hand Holds

Hand holds are built into both the left and right hand fender covers. The handles can be used to assist in mounting and dismounting the tractor.

J. Hydraulic Lift Lever

The hydraulic lift lever is located on the right fender. This lever is used to raise and lower the three point hitch lift arms.

- Move the lift lever fully rearward to raise the lift arms.
- Move the lift lever forward to lower the lift arms.
- Move the lift lever fully forward and to the right ahead of the float lock bracket to lock the lift in the float position.

K. Cup Holder

The cup holder is located on the right fender.

L. Amber Hazard Lights

The hazard lights are located on each side of the ROPS. The lights illuminate in a flashing mode when the hazard light switch is turned on. Always use the hazard lights when it is necessary to warn others that the tractor is being operated in the area.

M. Seat Adjustment Lever

The seat adjustment lever is located at the right/front of the seat. This lever is used to adjust the seat forward or backward.

N. Seat Belt

The seat belt, when properly adjusted and used in conjunction with the Rollover Protective Structure (ROPS), can greatly reduce the risk of serious injury or death to the operator if an accidental tractor overturn occurs.



WARNING: DO NOT use the seat belt if the ROPS is in the folded position, or the structure has been removed from the tractor.

O. Fuel Fill Cap

The fuel fill cap is located on the left fender beside the operator's seat.

P. Transmission Hi/Lo Range Shift Lever

The Hi/Lo range shift lever is located on the left fender. The lever has two speed range settings and a neutral position. The lever must be shifted into either the high or low range prior to depressing the forward or reverse pedal to drive the tractor.

- Push the lever fully forward to shift into the high range.
- Pull the lever fully rearward to shift into the low range.
- Move the lever to the center position to shift into the neutral position.



WARNING: Never attempt to shift the Hi/Lo range lever when the tractor is in motion.

Q. PTO Reverse Override Switch

The PTO reverse override switch is located on the left fender. Depress the front of the switch to engage the override which allows the PTO to operate while the tractor is traveling in the reverse direction. The indicator light in the override switch will illuminate when the switch is depressed to the "ENGAGED" position.

IMPORTANT: Once activated, this function remains activated until the ignition switch is turned to the OFF position for a duration of at least 20 seconds.



WARNING: Use EXTREME caution when operating PTO driven attachments while traveling in the reverse direction.

R. Parking Brake Lever

Parking
Brake
Symbol



Figure 7

The parking brake lever is located below the steering wheel in the dash panel. With the brake pedal fully depressed, push the parking brake lever downward and release the brake pedal to lock the parking brake.

S. Differential Lock Pedal

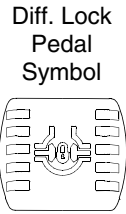

Figure 8

Located at the front of the left running board, the differential lock pedal engages the transmission differential lock.

The differential lock is used to gain additional traction when operating the tractor on wet or loose soil. When the pedal is depressed the rear wheels of the tractor are prevented from rotating independently of one another.



WARNING: When operating with the differential lock engaged, the tractor will be difficult to steer. Do not drive the tractor on roadways or at high speeds with the differential lock engaged.

NOTE: *Disengagement of the differential lock is recommended prior to turning the tractor on grass or other maintained surfaces — tire damage to the turf could occur.*

T. Choke Control Knob

The choke knob controls the position of the engine choke. Pull the knob out to choke the engine; push the knob in to open the choke.

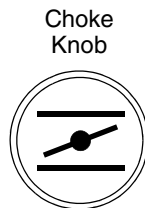

Figure 9

U. Hazard Light Switch

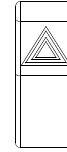

Figure 10

The hazard light switch is a rocker type switch located to the left of the steering wheel on the dash panel. Push the *top* of the hazard light switch downward to activate the flashing amber lights.



WARNING: Always activate the flashing hazard lights when operating the tractor on, or near, roadways.

V. Headlight Switch

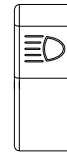

Headlight
Switch
Symbol

Figure 11

The headlight switch is a rocker type switch located to the left of the steering wheel on the dash panel. Push the *top* of the headlight switch downward to turn on the headlights and instrument panel gauge lights.

W. Foldable ROPS (Rollover Protective Structure)

The ROPS is installed to prevent or reduce injuries to the operator should the tractor accidentally overturn. The foldable feature allows the ROPS to be lowered when operating in areas with low overhead clearance. The protection provided by the ROPS is minimized if the seat belt is not used, and is eliminated when in the folded position.

X. Instrument Panel

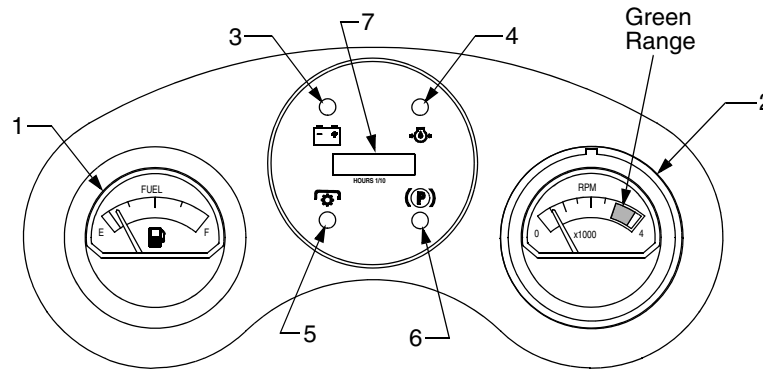

Figure 12

1. Fuel Gauge

The fuel gauge monitors the fuel level in the fuel tank. The needle pointing to the right indicates a full tank. The ignition switch must be in the ON position to activate the fuel gauge.

2. Tachometer

The tachometer shows the engine speed in revolutions per minute (RPM). Optimal engine operating speed is approximately 3400-3600 RPM. When operating PTO driven attachments the RPM indicator needle must be within the green range on the tachometer dial.

3. Battery Indicator Light

- Bulb illuminates and battery voltage is displayed briefly when the ignition switch is turned to the "ON" position.
- Illuminates to indicate the battery voltage has dropped below 11.5 (+0.5/-1.0) DC volts. The battery voltage is also displayed on the hour meter. If this indicator and display come on during operation, check the battery and charging system for possible causes and/or contact your Cub Cadet dealer.

4. Oil Pressure Indicator

This warning lamp indicates low engine oil pressure. If this indicator illuminates, stop the tractor immediately and check the engine oil level. If the oil level is within the operating range, but the light remains on, contact your *Cub Cadet* dealer. **NOTE:** *The oil pressure indicator may illuminate when the key switch is turned to the on position, but should turn off when the engine is started.*

5. PTO Engaged Indicator

This indicator illuminates whenever the PTO switch is pulled upward in the "ENGAGED" position while the key switch is turned to the "ON" position. Check this indicator if the engine will not crank with the key switch in the "START" position—the indicator should **not** be illuminated. If necessary, move the PTO switch to the "DISENGAGED" position.

6. Brake Engaged Indicator

This indicator illuminates whenever the brake pedal is fully depressed or the parking brake is engaged and the key switch is turned to the "ON" position. Check this indicator if the engine will not crank when the key switch is turned to the "START" position—the indicator should be illuminated. If necessary, fully depress the brake pedal.

7. Hour Meter/Battery Display

The hour meter records the hours and tenths of an hour (*right* most digit) that the tractor has been operated.

- The hour meter is activated when the key switch is turned to the "ON" switch position. Because the key switch may be accidentally left in the "ON" position, a record of the actual hours of operation should be kept to assure maintenance procedures are completed according to the schedule in this manual.
- When the key switch is turned to the "ON" position, the battery indicator light briefly illuminates and the battery voltage is briefly displayed. The display then changes to the accumulated hours.

SECTION 2: OPERATION

ROLLOVER PROTECTIVE STRUCTURE (ROPS)

This tractor is equipped with a foldable Rollover Protection Structure (ROPS) and seat belts. When used together they are effective in reducing injuries to the operator in the event of an accidental tractor rollover. The safety provided by the ROPS is minimized if the seat belt is not properly adjusted AND buckled. Refer to **ADJUSTMENTS** for seat belt adjustment.

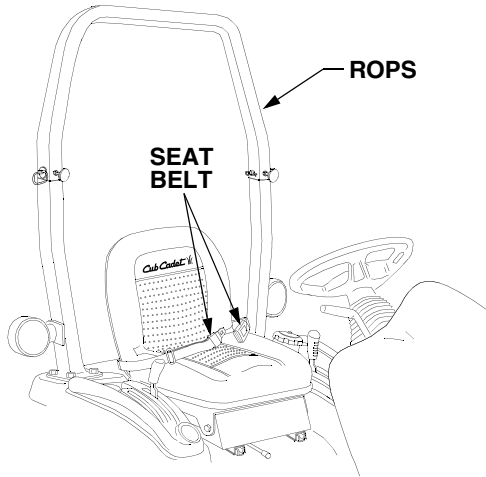

Figure 13



WARNING: Always wear the seat belt when operating the tractor equipped with a ROPS. However, if the ROPS has been folded or removed, the seat belt must not be used.

Use the following guidelines when using a tractor equipped with a ROPS:

- Be aware of overhead clearances in the area of operation. Check for clearance of door (or gate) openings and other overhead objects such as utility lines and tree branches. Overhead objects could catch the ROPS and upset the tractor.
- Do not modify the ROPS by drilling holes for, or welding accessories to the structure.
- Do not use the ROPS to pull objects with the tractor. Use ONLY the tractor rear tow plate for pulling.
- In the event of an accident, have the ROPS carefully inspected and, if necessary, replaced by your *Cub Cadet* dealer. Do not attempt to repair the ROPS.

FOLDING THE ROPS

The foldable ROPS feature allows the operator to quickly lower the ROPS to operate in areas where there is low overhead clearance. However, the ROPS should be used in the lowered position only when absolutely necessary. Operate with the ROPS in the 'up' position whenever possible.



WARNING: A folded ROPS does not provide rollover protection. When the ROPS is in the folded position, the seat belt must NOT be used.

Reposition the ROPS as follows:

- Loosen the two clamp knobs on the front of the ROPS to relieve their pressure on the ROPS. See Figure 14.
- Remove the two internal cotter pins, and, while supporting the ROPS, withdraw the hitch pins. See Figure 14. Carefully lower the ROPS.
- Reinstall the hitch pins and internal cotter pins for storage.

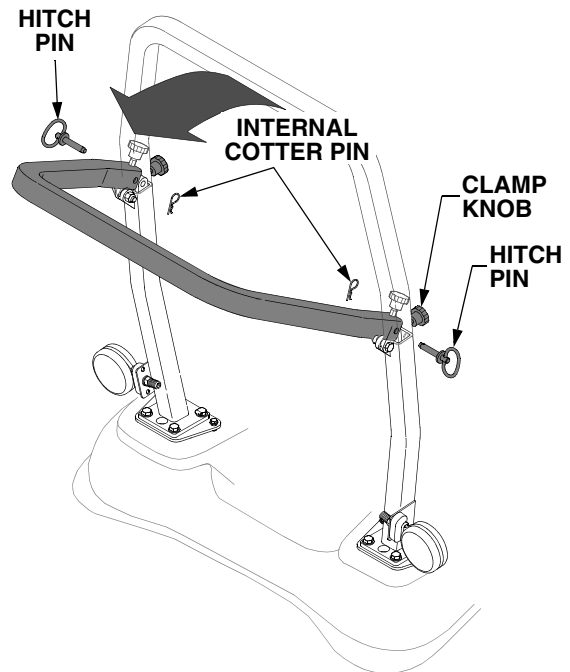

Figure 14

To raise the ROPS:

- Remove internal cotter pins and hitch pins and lift the ROPS into position.
- Insert the hitch pins and secure with the internal cotter pins.
- Tighten the clamp knobs against the ROPS.

SAFETY INTERLOCK SYSTEM

This tractor is equipped with a safety interlock system for the protection of the operator. If the interlock system should ever malfunction, do not operate the tractor. Contact your authorized *Cub Cadet* Dealer. The safety interlock system prevents the engine from cranking or starting unless the brake pedal is fully depressed, and the PTO is "OFF".

- The safety interlock system will shut off the engine if the operator leaves the seat before engaging the parking brake.
- The safety interlock system will shut off the engine if the operator leaves the seat with the PTO "ON", regardless of whether the brake lock is engaged.

NOTE: *The PTO switch must be moved to the "OFF" position to restart the engine.*

- The safety interlock system will shut off the PTO if the *reverse control pedal* is depressed, unless the reverse override function is activated.

NOTE: *If the reverse override function has been activated, it will remain activated until the ignition switch is turned to the "OFF" position for a 20 second duration.*

FUELING THE TRACTOR

Fill the fuel tank with only clean, fresh, unleaded regular grade gasoline with a minimum octane rating of 87. If engine knocking or pinging occurs, use a different source of gasoline or a higher octane rating.

Oxygenated Fuels. Some fuels, called oxygenated or reformulated gasoline, are gasoline blended with alcohols or ethers. Gasoline blended with either ethyl alcohol (maximum 10% by volume) or methyl tertiary butyl ether (MTBE, maximum 15%) are approved as fuels for the engine, provided they meet the minimum octane rating requirement. Other gasoline/alcohol or gasoline/ether blends are not approved for use in the tractor's engine. If any undesirable operating symptoms occur, use gasoline with a lower percentage of alcohol or ether.

Purchase fuel in a quantity that can be used within 30 days to assure fuel freshness. Do not use gasoline left over from the previous season to minimize gum deposits in the fuel system.



WARNING: Gasoline is extremely flammable and can be explosive in certain conditions. Do not fill the fuel tank when the engine is running or while the engine is hot. Tighten the fuel cap securely.

The fuel fill cap is located on the fender to the left of the seat. Unscrew the fuel cap and fill tank from an approved gasoline container. Immediately wipe up any spilled fuel.



WARNING: Never fill the fuel tank to the top of the filler neck. Expansion could result in overflow through the vents in the cap, allowing highly flammable fuel to come in contact with the operator.

NEW TRACTOR BREAK-IN PROCEDURES

Proper care during the first hours of operation will help to assure optimal performance from your new tractor.

- Never operate a new engine immediately under full load. Allow the engine to warm up.
- Avoid operating the engine for prolonged periods at either high or low speed with no load.
- Use the transmission's low speed range for heavy loads to avoid lugging down or stalling the engine due to overload.
- Closely monitor the engine oil and keep filled to the recommended level.
- After the first ten hours of operation, check the front wheel lug bolts and rear wheel lug nuts. If necessary, retorque to 60-70 ft. lbs.
- Perform all break-in maintenance procedures found in the MAINTENANCE section.

STARTING THE ENGINE



WARNING: Always sit in the operator's seat when starting the tractor. Never start the tractor from any other position.

- Operator must be sitting in the tractor seat.
- Pull the choke control knob out to the full choke position. Less choking may be necessary due to variations in temperature, grade of fuel, etc. Little or no choking will be needed when the engine is warm.
- Make sure the PTO switch is in the "OFF" position. **NOTE:** *The PTO light on instrument panel will be lit if the switch is in the "ON" position.*

- Move the throttle handle to midway between the “SLOW” and “FAST” position. Refer to Figure 15.

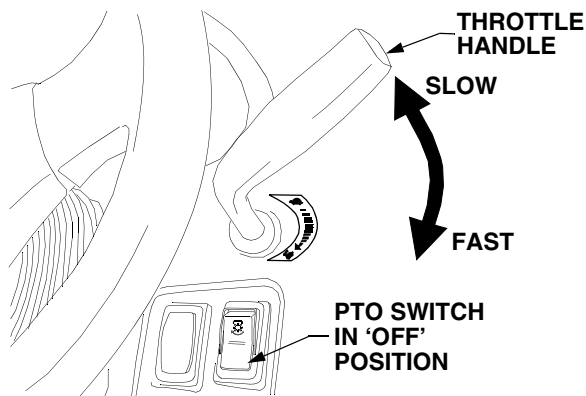

Figure 15

- Either fully depress and hold the brake pedal or engage the parking brake. **NOTE:** *The parking brake indicator on the instrument panel will light when the pedal is properly depressed.*
- Turn the ignition key clockwise to the “START” position and release it as soon as the engine starts; however, do not crank the engine continuously for more than 10 seconds at a time. If the engine does not start within this time, turn the key to “OFF” and wait a minute to allow the engine’s starter motor to cool. Try again after waiting. If after a few attempts the engine fails to start, do not keep trying to start it with the choke closed as this will cause flooding and make starting more difficult. Instead, fully open the choke and start the engine.

NOTE: *Upon start-up, a metallic ticking noise may occur. This is caused by hydraulic lifter leakdown during storage. The noise will normally cease within the first minutes of engine warm up. If the noise continues, increase the engine speed to mid-throttle and allow the engine to run for several minutes. If the noise persists, contact your Cub Cadet dealer.*



WARNING: *If the starter disengages the engine flywheel, but the engine does not continue to run, allow the engine to come to a complete stop before attempting to restart the engine. Damage to the starter may result from failure to do so.*

- After the engine starts, slowly release the brake pedal. As the engine warms up, gradually push the choke control knob all the way in. Do not use the choke to enrich the fuel mixture, except as necessary to start the engine.

- Allow the engine to run for a few minutes at mid throttle before putting the engine under load.
- Observe the instrument panel. If the battery indicator light or oil pressure light come on, immediately stop the engine. Have the tractor inspected by your *Cub Cadet* dealer.

COLD WEATHER STARTING

Be sure to use the proper oil for the expected temperatures and use winter grade fuel. Follow the normal engine starting instructions above. However, allow the engine ample time to warm up before putting the tractor under load.

USING JUMPER CABLES TO START ENGINE



WARNING: *Batteries contain sulfuric acid and produce explosive gasses. Make certain the area is well ventilated, wear gloves and eye protection, and avoid sparks or flames near the battery.*

If the battery charge is not sufficient to crank the engine, recharge the battery. If a battery charger is unavailable and the tractor must be started, the aid of a booster battery will be necessary. Connect the booster battery as follows:

- Connect the end of one cable to the disabled tractor battery’s positive terminal; then connect the other end of that cable to the booster battery’s positive terminal.
- Connect one end of the other cable to the booster battery’s negative terminal.
- Connect the other end of that cable to the frame of the disabled tractor, as far from the battery as possible.
- Start the disabled tractor following the normal starting instructions previously provided; then disconnect the jumper cables in the exact reverse order of their connection.
- Have the tractor’s electrical system checked and repaired as soon as possible to eliminate the need for jump starting.

STOPPING THE ENGINE

- Place the PTO switch in the “OFF” position.
- Place the throttle control lever somewhere between the mid and full throttle position.
- Turn the ignition key to the “OFF” position and remove the key from the ignition switch.

NOTE: *Always remove the key from the ignition switch to prevent accidental starting or battery discharge if the equipment is left unattended.*

DRIVING THE TRACTOR



WARNING: Avoid sudden starts, excessive speed and sudden stops.



WARNING: Do not leave the seat of the tractor without disengaging the PTO and engaging the parking brake. If leaving the tractor unattended, turn the ignition key off and remove key.

- Adjust the operator's seat to the most comfortable position that allows you to operate all controls and pedals. See seat adjustment in the **ADJUSTMENTS** section.



WARNING: DO NOT use the seat belt if the ROPS has been lowered or structure has been removed from the tractor.

- Adjust the seat belt to fit snugly but comfortably around your lap, then buckle the seat belt. Refer to **ADJUSTMENTS** section.
- Shift the transmission Hi/Lo range shift lever on the left fender to the desired speed setting. Refer to **USING THE HI/LO RANGE SHIFT LEVER** sub-section below.
- Use the tractor and/or auxiliary hydraulic lift lever(s) to raise all tractor attachments from the ground if transporting the tractor to a work site.
- Depress the brake pedal to release the parking brake, then slowly release the brake pedal.
- Move the throttle handle to the position where the engine operates best for the load to be handled (normally 3500-3600 RPM).
- Slowly depress either the forward or reverse pedal to move the tractor in the desired direction. Refer to **USING THE FORWARD and REVERSE PEDALS** in paragraphs below.

STOPPING THE TRACTOR

- Fully depress the brake pedal to bring the tractor to a complete stop. Push downward on the parking brake lever and release the pedal to engage the parking brake. See Figure 16.
- Depress the rear of the PTO switch to disengage the PTO.
- Place the throttle control lever somewhere between the mid and full throttle position.

- Turn the ignition switch to "OFF" and remove the key from the switch before dismounting.
- Depress the button in the center of the seat belt buckle to release the seat belt.

USING THE FORWARD AND REVERSE PEDALS

The hydrostatic transmission provides constantly variable ground speeds within the speed rating of each (HI/LO) transmission range. The tractor speed is controlled by the forward and reverse pedals on the front of the *right* running board.

The forward and reverse pedals are self neutralizing. The transmission and pedals return to neutral when the pedals are released and the tractor will slow to a stop. **NOTE:** Use the brake pedal to stop the tractor.

- To move forward, slowly depress the forward control pedal (See Figure 16) until the desired speed is achieved. The speed of the tractor is directly related to the distance the pedal is depressed.

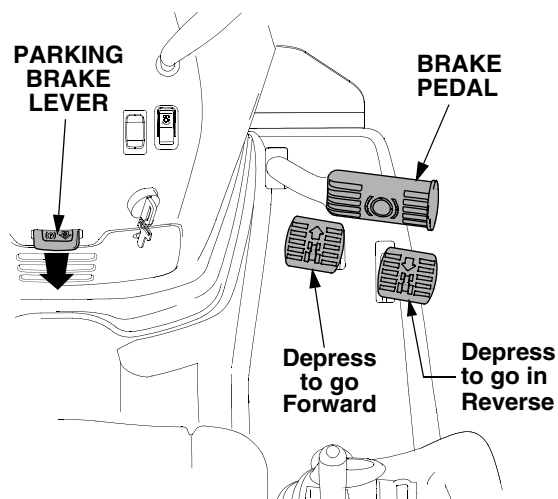

Figure 16

- To move in reverse, check that the area behind is clear then slowly depress the reverse control pedal. Refer to Figure 16.

NOTE: Do not use the forward or reverse control pedals to change the direction of travel when the tractor is in motion. The abrupt direction change may unseat the operator and will cause premature wear in the transmission. Allow the tractor to stop before changing directions.

USING THE HI/LO RANGE SHIFT LEVER



WARNING: The tractor must be stopped before engaging or disengaging the transmission Hi/Lo range shift lever. Shifting while the tractor is in motion will cause damage to the transmission.



WARNING: Always maintain a tractor speed that allows for complete control and stability of the machine. Be aware of dangerous areas or conditions.

Referring to Figure 17, pull the lever to the right side of the slot to clear the shift gate, then shift the lever as follows :

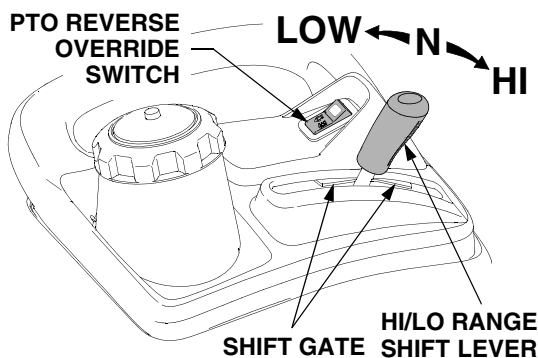

Figure 17

Hi range — Shift the lever fully forward in slot.

Forward speed 0 to 8.0 mph.

Reverse speed 0 to 4.0 mph.

Hi range is normally used for transport and can be used with some tractor attachments

LOW range — Shift the lever fully rearward in slot.

Forward speed 0 to 4.0 mph.

Reverse speed 0 to 2.0 mph.

Low range is recommended for use with most PTO driven tractor attachments. **Low range must be used when climbing or descending slopes.**

NEUTRAL — Shift the lever to the center of slot. Disengages the transmission drive.

Use **ONLY** for towing or moving the tractor when not under power.

DRIVING ON SLOPES



WARNING: Do not operate on inclines with a slope in excess of 15 degrees (a rise of approximately 2-1/2 feet every 10 feet). The tractor could overturn and cause serious injury.

IMPORTANT: *Always shift the transmission into the LOW speed range BEFORE beginning the climb or descent of any slope.*

Operate the tractor up and down slopes, never across slopes. Do not drive so that the tractor may tip over sideways

Before operating the tractor on a slope, walk the slope to look for possible hazards such as rocks, mounds, stumps, or surface irregularities which could cause the tractor to be upset.

Back the tractor with attachment up the steepest portion of each slope you intend to work. If the tractor cannot negotiate the slope in reverse, the slope is too steep to be worked.

Avoid turns when driving on a slope. If a turn must be made, turn down the slope. Turning up a slope greatly increases the chance of a roll over.

Avoid stopping when driving up a slope. If it is necessary to stop while driving up a slope, start up smoothly and carefully to reduce the possibility of flipping the tractor over backward.

USING THE DIFFERENTIAL LOCK PEDAL

Depressing the differential lock pedal engages a mechanism in the transmission that locks the differential. This prevents the rear wheels from rotating independently of each other and provides constant power to both rear wheels when additional traction is needed.

IMPORTANT: *Do not engage the differential lock when one of the rear wheels is rotating. Stop the wheel rotation and then engage the differential lock.*



WARNING: When operating with the differential lock engaged, the tractor will be difficult to steer. Do not drive the tractor on roadways or at high speeds with the differential lock engaged.

- Fully depress and hold the differential lock pedal to engage the transmission differential lock. Release the pedal to disengage the differential lock. See Figure 18.

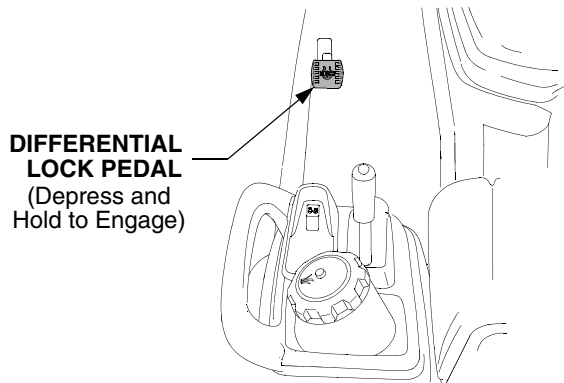

Figure 18

NOTE: Because of the drive load on the internal engagement mechanism, releasing the differential lock pedal may not always disengage the differential lock. It may be necessary to slow the tractor, or reverse the direction of travel, to disengage the differential lock.

USING THE HYDRAULIC LIFT LEVER

The hydraulic lift system provides power for raising and positioning three point hitch and belly mounted equipment. To raise an attachment using the hydraulic lift system, the engine must be running. Generally, an attachment can be lowered with the engine running or off.

- Move the lift lever forward in the slot to lower the equipment to the desired height setting. Refer to Figure 19.

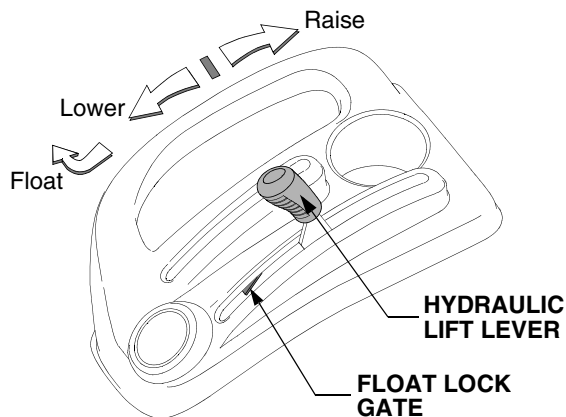

Figure 19

- Move the lift lever rearward in the slot to raise the equipment.
- Move the lift lever fully forward and to the right ahead of the float lock gate to lock the lift in the float position.

ENGAGING THE PTO



WARNING: The operator must be in the seat at all times when the PTO is engaged. If the operator should leave the seat without turning off the PTO switch, the tractor's engine will shut off.

- Move the throttle handle to the mid throttle position. See Figure 20.
- Push the *top* of the PTO switch downward to engage the PTO (See Figure 20). The PTO light on the instrument panel will come on.
- Observing the tachometer on the instrument panel, use the throttle handle to increase the engine speed to the PTO operating range (3500-3600 rpm).

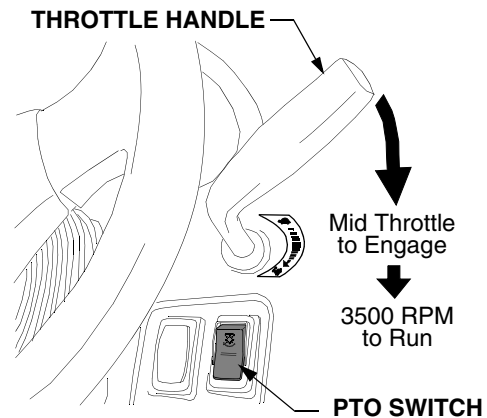

Figure 20

- Push the *bottom* of the switch downward to disengage the PTO.

IMPORTANT: Normally the PTO will not operate when the tractor is driven in the reverse direction. The PTO reverse override switch must be activated to operate the PTO while traveling in reverse.

USING THE PTO REVERSE OVERRIDE SWITCH

The PTO reverse override switch, located on the *left* fender, allows the PTO to operate while the tractor is traveling in the reverse direction. See Figure 21.

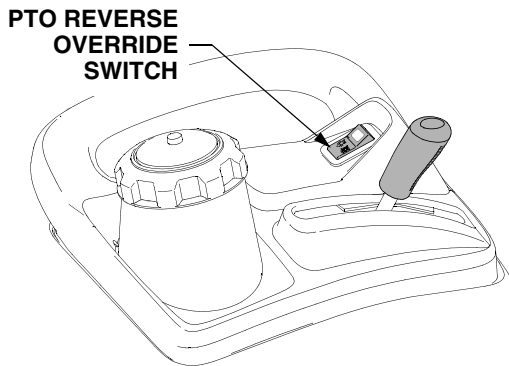

Figure 21

- The PTO should first be engaged using the PTO switch on the dash panel.
- Depress the front of the override switch to activate the reverse override system. The light in the override switch will come on.

IMPORTANT: *Once activated, the reverse override will remain activated until the ignition switch is turned to the OFF position. If the override switch is illuminated, the system is activated.*



WARNING: Use **EXTREME CAUTION** when operating PTO driven attachments while traveling in the reverse direction.

HEADLIGHTS

Always use the headlights for after dusk and pre-dawn operation of the tractor. The lights not only illuminate the work area, but also increase the visibility of the tractor for anyone who might enter the area of operation.

- To turn on the headlights, depress the top end of the headlight switch located to the left of the steering wheel.
- To turn off the headlights, depress the bottom of the light switch.

Use of the headlights, along with a SMV (Slow Moving Vehicle) emblem, is also recommended when operating the tractor on or near roadways to increase visibility to traffic.

HAZARD LIGHTS

Always use the flashing amber hazard lights along with the SMV (Slow Moving Vehicle) emblem when operating the tractor on, or near, roadways. Also activate the hazard lights when necessary to warn others that the tractor is being operated in the area.

- To turn on the flashing hazard lights, depress the top end of the hazard light switch located to the left of the headlight switch.
- To turn off the hazard lights, depress the bottom of the light switch.

USING THE TOP LINK RETAINER HOOK

The top link hook is provided to retain the top link of the three point hitch when not in use.

To utilize the top link hook, proceed as follows:

- Manually lift the 3-pt. hitch top link fully upward.
- Pivot the link hook from its storage position to the center and lower the top link into the hook of the rod. See Figure 22.

IMPORTANT: *When using the three point hitch, the retainer hook must be pivoted fully rearward to avoid interference with the top link.*

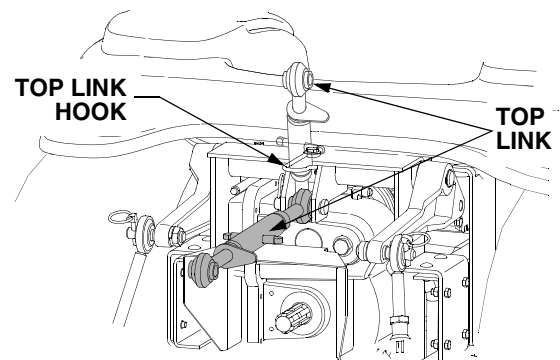

Figure 22

REMOVING THE REAR PTO COVER

The rear PTO cover is a safety feature designed to prevent items from accidentally being caught by the rotating shaft. The cover should be removed only when the rear PTO is being utilized.

To remove and reinstall the cover, proceed as follows:

- Loosen the two screws on the left side of the cover. Refer to Figure 23.
- Slide the cover to the right until the slots of the cover are free of the screws and pull the cover off. See Figure 23.

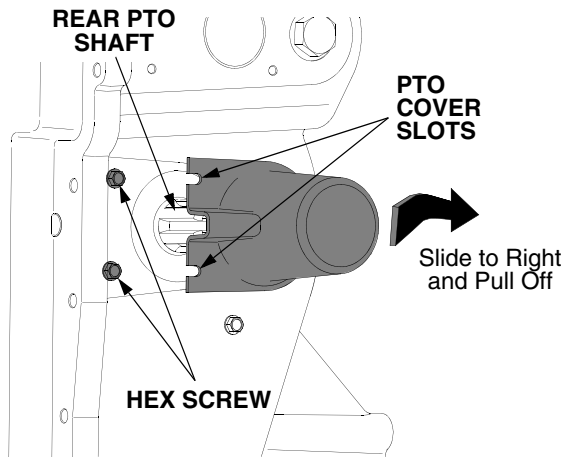

Figure 23

- When finished using the rear PTO, slide the cover fully onto the shaft; then slide the cover to the left until the slots are underneath the screw heads. Tighten the screws to secure the cover. Refer to Figure 23.

USING THE HITCH PLATE

Use only the hitch plate (Refer to Figure 24), for towing pull-behind equipment (carts, trailers, etc.) or dragging loads.

Raise the lower links of the three point hitch to their highest position to prevent interference with the towed equipment.

IMPORTANT: *When transporting pull-behind equipment on public roadways, always use a safety chain to supplement the connection between the tractor and towed equipment. The safety chain must have a strength rating equal to or greater than the gross weight of the equipment being towed.*

USING THE THREE POINT HITCH



WARNING: Always disengage the PTO, stop the engine, and set the parking brake before dismounting the tractor to connect, disconnect, or adjust three point hitch mounted implements.

Use the rear three point hitch system to attach three point mounted implements, which are normally driven by the rear PTO. Use the tractor's hydraulic lift system to raise and lower the three point hitch and set the height position of the implement.

Refer to the **ADJUSTMENTS** section for instructions on adjusting the RH adjustable lift link, top hitch link, and hitch chains. See Figure 24.

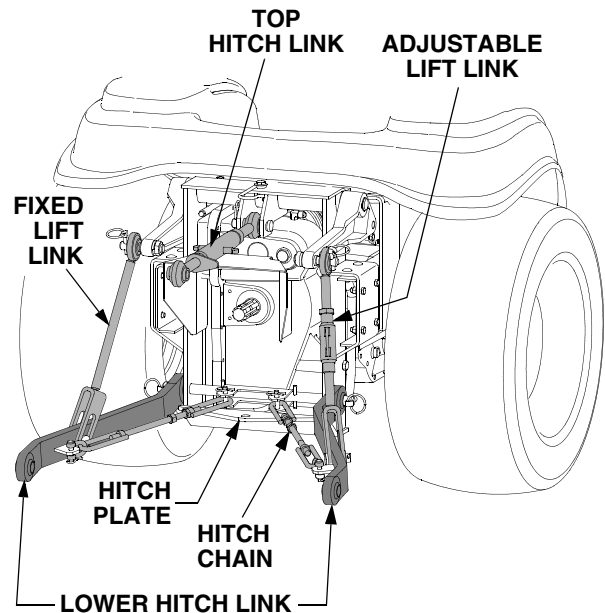

Figure 24

TRACTOR WEIGHTING

When implements are installed on either the front or rear of the tractor, the normal balance of the tractor is altered.

- As a rear mounted implement is raised to the transport position, the balance point of the tractor shifts rearward, which may result in a loss of steering control and tractor stability.
- When a front mounted implement is raised, the balance point shifts forward and may result in a loss of traction and stability.

To counterbalance these weight shifts, weight should be added to the tractor in the form of either front cast iron weights, a rear weight box, and/or liquid tire ballast. Only enough weight should be added to obtain good traction, control, and stability. Excessive weight will unnecessarily load down the tractor's engine and transmission.

INSTALL **ONLY** EQUIPMENT APPROVED FOR USE ON THE 5000 SERIES TRACTOR.

Front Weights

To counterbalance three point hitch mounted equipment, a weight bracket/bumper kit and cast iron weights are available from your *Cub Cadet* dealer. Refer to the Weighting Table for the proper ballast to be added to the front of the tractor.

Weighting the Rear of the Tractor

To counterbalance front mounted equipment, use a rear weight box, and/or liquid ballast in the rear tires. Refer to the Weighting Table for the proper ballast to be added to the rear of the tractor.

NOTE: *Consult with your Cub Cadet dealer about having liquid ballast added to your tires, and for any special maintenance after the procedure is performed. Because special equipment and a familiarity with the practice is required, only a qualified tire technician should perform this procedure.*

TRACTOR WEIGHTING TABLE		
Equipment Installed on Tractor	Method of Weighting	Weight Required
Front Loader	Rear Weight Box AND Ballast Added to Rear Tires	400 pounds in weight box (** with center of gravity approx. 33" from center of rear axle and 20" above ground-See note below) AND a 86 pounds of liquid ballast added to each rear tire.
Front Loader and Approved Rear Mounted Equipment	Ballast Added to Rear Tires	86 pounds of liquid ballast added to each rear tire
Rear Mounted Finish Mower	Front Weight Bracket and Suitcase Weights	A minimum of four suitcase weights (168 pounds)
Rear Mounted Tiller	Front Weight Bracket and Suitcase Weights	A minimum of two suitcase weights (84 pounds)
Rear Mounted Blade, Box Blade, Rake	Front Weight Bracket and Suitcase Weights	A minimum of two suitcase weights (84 pounds)
Rear Mounted Post Hole Digger	Front Weight Bracket and Suitcase Weights	A minimum of four suitcase weights (168 pounds)
Front Snow Thrower	None Required	None Required
Front Blade	None Required	None Required

** If the center of gravity of the additional weight is positioned closer to the rear axle and higher above the ground, more weight must be added. If the additional weight is carried farther from the axle and lower, less weight may be used.

SECTION 3: ADJUSTMENTS

ADJUSTING THE SEAT

For the comfort of the operator, a single lever adjustable seat is provided to set the fore to aft position of the seat. Adjust the seat to the most comfortable position that allows you to operate all controls and pedals.



WARNING: Do not adjust the seat when the tractor is moving, as this could cause the operator to lose momentary control of the tractor and result in an accident.

- To adjust the seat, pivot the seat adjustment lever to the left and hold while repositioning the seat to the desired position.
- After repositioning the seat, release the lever to lock the seat in position. Slide the seat either slightly forward or rearward to assure it is locked, or until engagement of the lock is felt. See Figure 25.

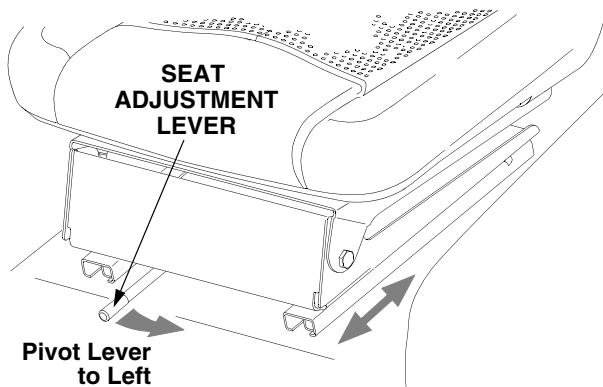

Figure 25

ADJUSTING THE SEAT BELT



WARNING: Always wear the seat belt when operating the tractor equipped with a ROPS. If the ROPS has been lowered or removed, the seat belt should not be used.

NOTE: If the belt is too long or too short to be properly adjusted using the upper belt webbing, the adjustment clip should be repositioned. To do so, firmly grasp the adjustment clip and pull the lower webbing through the clip. Move the clip toward the anchor point at the seat to shorten the belt, or toward the buckle link to lengthen the belt.

Adjust the final length of the seat belt using the adjuster clip, buckle link, and upper belt webbing on the *right* half of the belt.

- To lengthen the belt, hold the ends of the adjuster clip and tip upward the side of the clip toward the buckle link. See Figure 26.
- While holding the clip, pull the upper webbing of the belt through the clip toward the buckle link. See Figure 26.
- Hold the belt and pull the buckle link to the *left* to remove the slack in the upper webbing of the belt between the adjuster clip and the link.

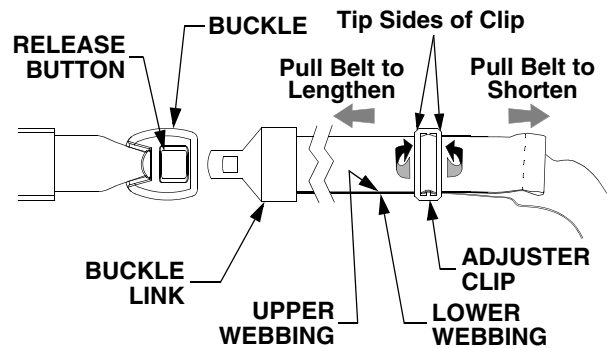

Figure 26

- To shorten the belt, tip the other side of the clip upward, pull the free end of the belt webbing to the *right*, and pull the buckle link to the *left* to remove the slack.

THREE POINT HITCH ADJUSTMENTS

- Adjust the RH adjustable lift link to *level* the lower hitch links. Loosen the jam nut and turn the adjustment tube as shown in Figure 27 to shorten or lengthen the lift link. Tighten the jam nut against the adjustment tube after adjusting.

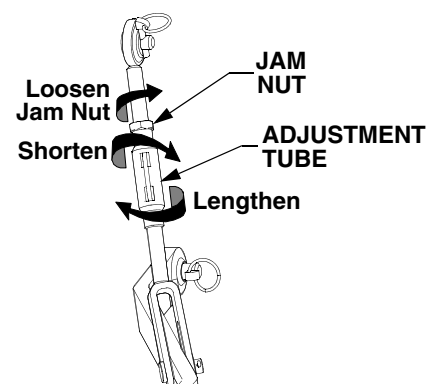

Figure 27

- The length of the upper hitch link is normally determined by the design of each implement. To adjust the upper hitch link, loosen the locking lever and turn the adjustment tube as shown in Figure 28. After the appropriate length is attained, tighten the locking lever. If correctly adjusted, the upper hitch link will be parallel or nearly parallel to the lower hitch links.

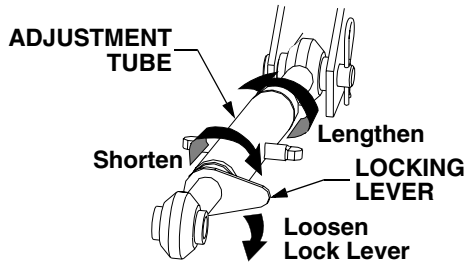

Figure 28

- The length of the hitch chains limit the side-to-side movement of the hitch lower links. To adjust the length of the hitch chains, loosen the jam nut and turn the hex collar on the adjustment rod as shown in Figure 29. Tighten the jam nut after adjusting.

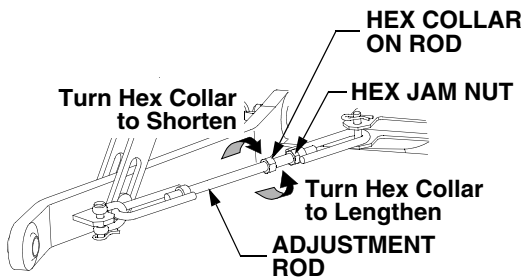

Figure 29

ADJUSTING FRONT WHEEL TOE-IN

The front wheel toe-in is set at the factory and should maintain the proper setting. However, the toe-in should be checked periodically and readjusted if necessary.

CHECK THE TOE-IN AS FOLLOWS:

- Place the tractor on a level surface with the wheels in the straight ahead position.
- Place an easily visible mark on the center lines of both front tires at the horizontal center line of the wheel.
- Measure and record the distance 'A' between the two marks. See Figure 30.
- Roll the tractor forward or rearward until the marks are at the horizontal center line at the rear of the wheels. Measure and record the distance 'B' between the marks. See Figure 30.

- Distance 'A' should be 1/8"-1/4" less than distance 'B' if the toe-in is correct. If it is not, readjust the toe-in.

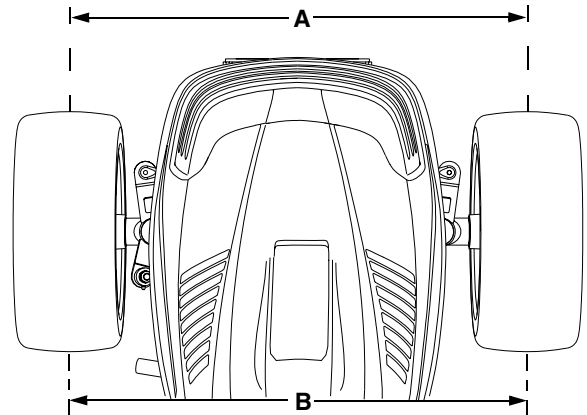

Figure 30

READJUST THE TOE-IN AS FOLLOWS:

NOTE: The left ball joint and jam nut are left hand threaded.

- Loosen the jam nuts at both the LH and RH ball joints. See Figure 31.
- Slide an open-end wrench onto the flat area at either end of the tie rod and turn the tie rod as follows:

Rearward to shorten the tie rod and increase the toe-in. See Figure 31.

Forward to lengthen the tie rod and decrease the toe-in. See Figure 31.

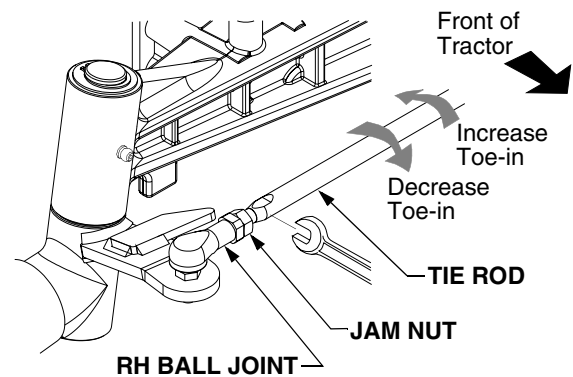

Figure 31

- Readjust the tie rod as necessary to obtain the correct toe-in, then tighten the jam nuts against the ball joints.

ADJUSTING THE BRAKES

The tractor brakes are adjusted at the factory and should experience minimal wear if the tractor is operated normally. However, all brake pads are subject to wear and at some point the brake linkage may have to be adjusted.

Check the brakes as follows:

- Place the tractor on a level surface. Stop the tractor engine.
- From beneath the RH running board, remove the internal cotter pin to disengage the brake rod ferrule from the brake pedal. Position the brake rod to make certain there is no pull on the brake actuator arm. See Figure 32.
- From the rear of the tractor, use a feeler gauge to measure the gap between the outer brake

puck and the brake disc. The gap should measure between .012 and .015". See Figure 32.

- If the gap is greater than .015", tighten the hex nut on the brake assembly until the gap is within the tolerance.
- Position the ferrule to align with the hole in the brake pedal. If the ferrule does not align with the hole, loosen the jam nut by turning it away from the ferrule
- Adjust the ferrule on the brake rod to align with the brake pedal hole, then tighten the jam nut against the ferrule.
- Insert the ferrule in the brake pedal and secure with the internal cotter pin.
- Repeat the previous steps to check and, if necessary, adjust the LH brake assembly.

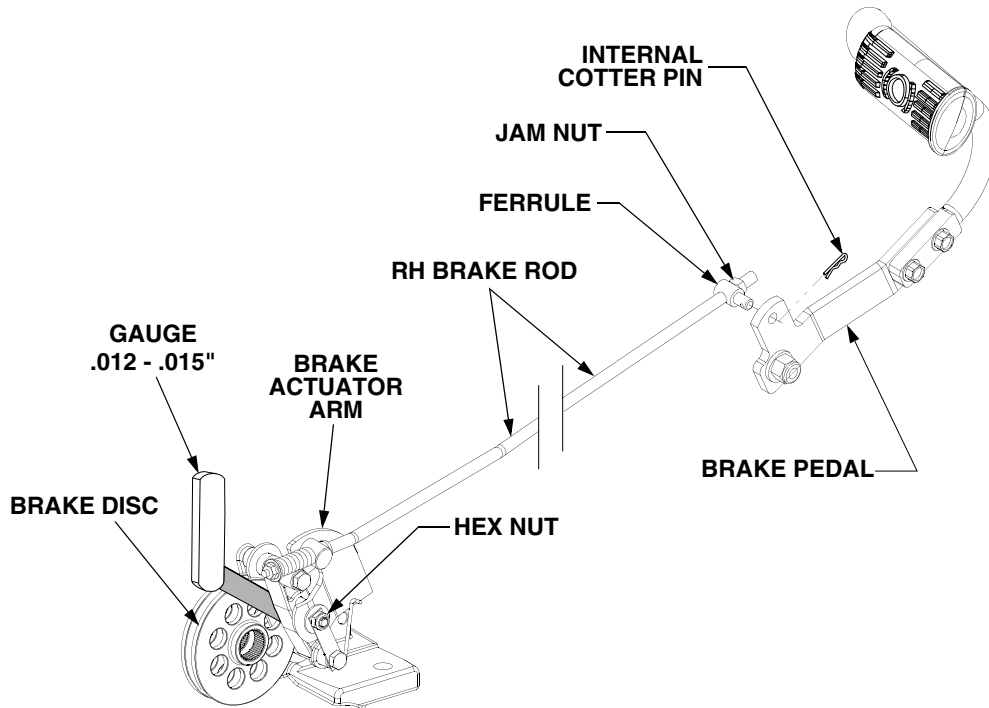

Figure 32

SECTION 4: TRACTOR MAINTENANCE

The service life and reliability of any machine depends upon the care it is given. Proper lubrication and maintenance is a vital part of that care. Using the *Lubrication and Maintenance Chart* as a guide, monitor the hourmeter on the instrument panel to ensure the required maintenance procedures are performed. The maintenance schedule reflects the minimal requirements to maintain the equipment. More frequent inspections and maintenance is preferable.

Make certain that all lubrication fittings are installed and functioning. Wipe away all old grease and dirt from the lube fittings to prevent foreign materials from entering as the new grease is applied. Use a pressure lubricating gun to force in new grease.

Apply pressure until clean grease emerges from the lubrication point.

Miscellaneous working parts not provided with lubrication fittings should be oiled regularly with a good grade of lubricating oil.

Lubricate the tractor thoroughly before taking it to a remote location for a prolonged period of time.

Lubricant is cheap. Use plenty of it. Worn parts can be expensive to replace.

Store your supply of lubricating grease and oil in clean, covered containers to protect them from dust and dirt. Keep the lubricating gun nozzle clean.

LUBRICATION TABLE

Application	Type of Lubricant	General Information				
		Capacity	API Classification	Anticipated Ambient Temp.	SAE Viscosity	Description
Engine	Engine Oil	Approx. 2.1 Qts. w/Filter	SG, SH, or SJ	Below 32°F	5W-20 † 5W-30 †	Use High Quality Engine Oil
				0°F to 100°F	10W-30 †	Cub Cadet 737-3030A (1Qt.)
Hydrostatic Transmission and Hydraulic System	Cub Cadet Drive System Fluid Plus	Approx. 20 Qts. (5.0 Gal.)	Use Cub Cadet Drive System Fluid Plus 737-3120 (1 Qt.) 737-3121 (1 Gal.)			
Lube Fittings	Grease	As Needed	Use Cub Cadet 251H EP Grease 737-3034 (14.5 Oz. Cartridge)			

† Using multi grade oils (5W-20, 5W-30, and 10W-30) will increase oil consumption. Check the engine oil level frequently when using them.

LUBRICATION AND MAINTENANCE CHART (ILLUSTRATION)

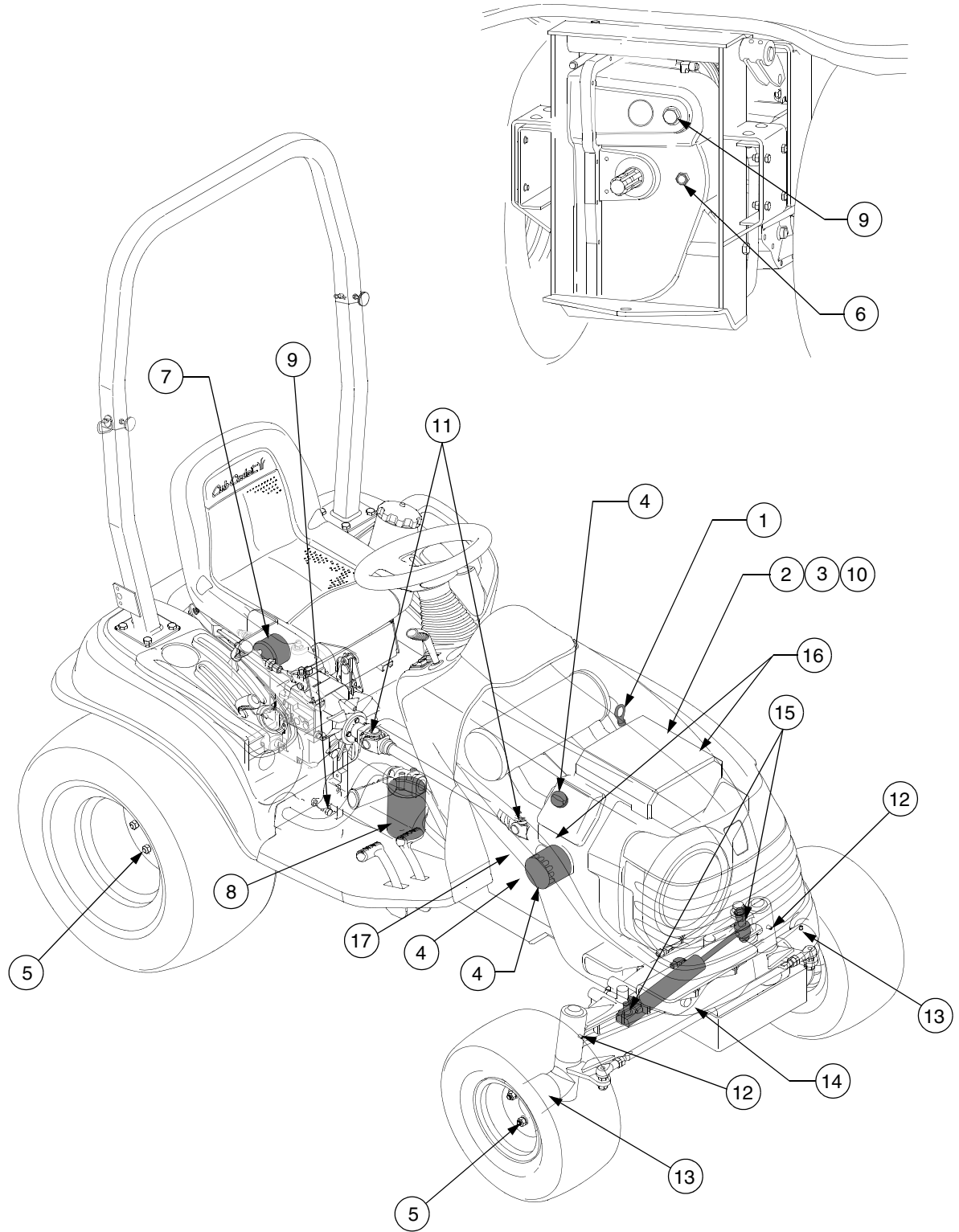

LUBRICATION AND MAINTENANCE CHART

Ref. No.	Operation to be Performed	Service Intervals								
		Before each use	Every 10 Hours	Every 25 Hours	Every 50 Hours	Every 100 Hours	Every 200 Hours	Every 300 Hours	Every 400 Hours	Before Storage
1	Check Engine Oil Level	•								
2	Check Air Cleaner	•								
3	Clean Air Cleaner Foam Precleaner Element			†						
4	Change Engine Oil and Replace Oil Filter					•				•
5	Retorque Front Wheel Lug Bolts and Rear Wheel Lug Nuts		first 10 hours			•				
6	Check Transmission Oil Level	•								
7	Replace Hydrostatic Transmission Oil Filter			first 25 hours		•				
8	Replace Hydraulic System Filter			first 25 hours			•			
9	Replace Hydraulic/Hydrostatic Oil						•			
10	Replace Air Cleaner Paper Element					†				
11	Grease Drive Shaft (both ends)				•					•
12	Grease Front Steering Knuckles		•							•
13	Grease Front Axle Wheel Hubs		•							•
14	Grease Front Pivot Axle		•							•
15	Grease Power Steering Cylinder (both ends)				•					•
16	Clean and Re-gap Spark Plugs					•				
17	Check Fuel Filter						•			•

† More often when operating under dusty conditions.

ACCESSING THE ENGINE COMPARTMENT



WARNING: If the tractor has been recently operated, engine surfaces (including the radiator) will be HOT. Allow the engine to cool before opening the hood, or use extreme caution to avoid burns when the hood is open.

To raise the hood, locate the hood latch below the hood notch at the front of the tractor. Pull the hood latch upward to release the front of the hood. See Figure 33.

- Fully raise the hood so that the hood spring cylinders hold the hood in the raised position.

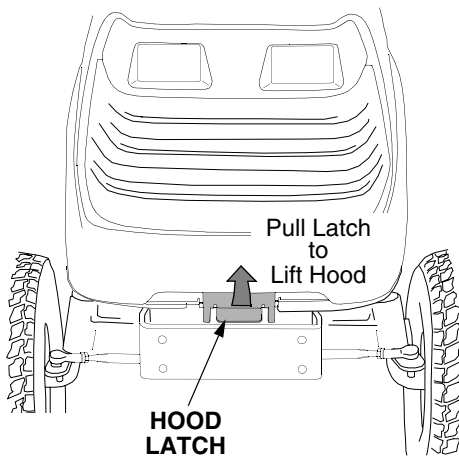

Figure 33

If Equipped With Side Panels, remove them as follows:

- Flip the tabs of the two quick release fasteners up and turn to align with the slots in the side panel. See Figure 34.
- Pivot the top of the side panel over and off the quick fastener tabs.
- Pivot the top of the side panel until the two tabs at the bottom of the panel can be withdrawn from the slots of the side panel mounting brackets; then remove the side panel. See Figure 34.

To reinstall the side panels:

- Insert the two side panel tabs into the slots of the side panel mounting brackets. See Figure 34.
- Pivot the top of the panel toward the tractor and over the tabs of the quick release fasteners.
- Pull the quick fastener tabs slightly outward and rotate 1/4 turn (perpendicular to slot) to lock the side panels in place. Flip the tabs down.

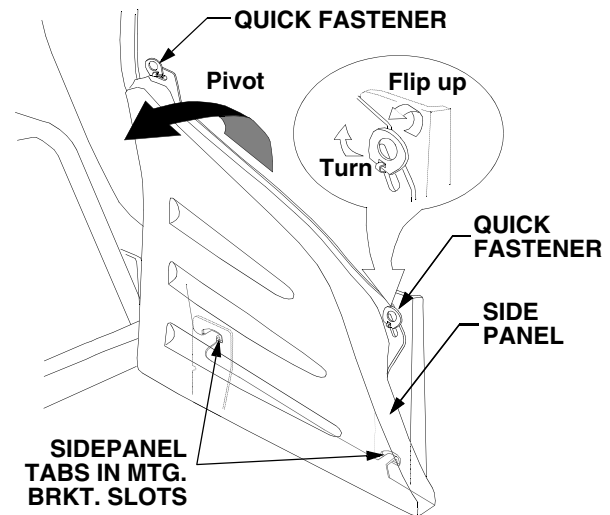

Figure 34

Close the hood by pushing the hood firmly downward until the hood latch fully engages.

GENERAL BATTERY INFORMATION



WARNING:

- Battery posts, terminals and related accessories contain lead and lead compounds. Wash hands after handling.
- Should battery acid accidentally splatter into the eyes or onto the skin, rinse the affected area immediately with clean cold water. If there is any further discomfort, seek prompt medical attention.
- If acid spills on clothing, first dilute it with clean water, then neutralize with a solution of ammonia/water or baking soda/water.
- NEVER connect (or disconnect) battery charger clips to the battery while the charger is turned on, as it can cause sparks.
- Keep all sources of ignition (cigarettes, matches, lighters) away from the battery. The hydrogen gas generated during charging can be combustible.
- As a further precaution, only charge the battery in a well ventilated area.
- Always shield eyes and protect skin and clothing when working near batteries.



WARNING: Batteries contain sulfuric acid and may emit explosive gases. Use extreme caution when handling batteries. Keep batteries out of the reach of children.

BATTERY REMOVAL



WARNING: Battery posts, terminals and related accessories contain lead and lead compounds. Wash hands after handling.

The battery is located at the front of the tractor beneath the hood.

To remove the battery:

- Open the tractor hood as described in the previous sub-section.
- Remove the two wing nuts and the battery holddown strap from the battery holddown rods. See Figure 35.
- Spread the locking clips on the sides of the terminal covers and lift the tops of the covers to expose the battery connections. See Figure 35.
- Loosen the cable clamp of the black negative battery lead, then lift the negative cable and its terminal cover off the negative battery post (marked NEG). Move the cable away from the negative battery post.
- Repeat the above procedure to remove the cable and cover from the positive battery post (marked POS).
- Carefully lift the battery out of the tractor.

Install the battery by repeating the above steps in the reverse order.



WARNING: Always connect the positive lead to the battery before connecting the negative lead. This will prevent sparking or possible injury from an electrical short caused by contacting the tractor body with tools being used to connect the cables.

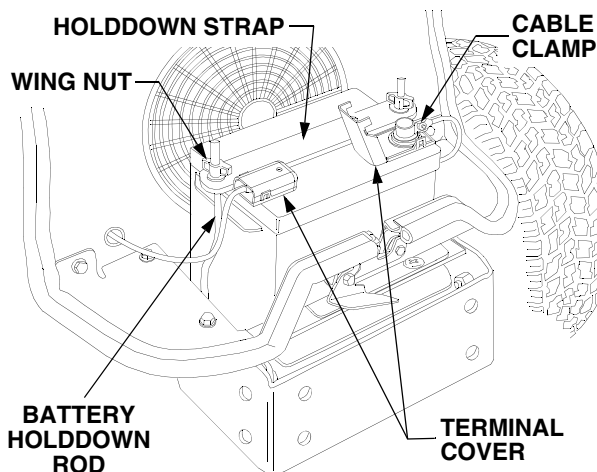

Figure 35

CHARGING THE BATTERY

Test and, if necessary, recharge the battery after the tractor has been stored for a period of time.

- A voltmeter or load tester should read 12.6 volts (DC) or higher across the battery terminals.
- Charge the battery with a 12-volt battery charger at a **MAXIMUM** rate of 10 amps.

Voltmeter Reading	State of Charge	Charging Time
12.7	100%	Full Charge
12.4	75%	90 Min.
12.2	50%	180 Min.
12.0	25%	280 Min.

BATTERY MAINTENANCE

The battery is filled with battery acid and then sealed at the factory. However, even a “maintenance free” battery requires some maintenance to ensure its proper life cycle.

- Spray the terminals and exposed wire with a battery terminal sealer, or coat the terminals with a thin coat of grease or petroleum jelly, to protect against corrosion.
- Always keep the battery cables and terminals clean and free of corrosion.
- Always keep the terminal covers in place and closed over the battery terminals.
- Avoid tipping. Even a sealed battery will leak electrolyte when tipped.

BATTERY STORAGE

- When storing the tractor for extended periods, disconnect the negative battery cable. It is not necessary to remove the battery.
- All batteries discharge during storage. Keep the exterior of the battery clean, especially the top. A dirty battery will discharge more rapidly.
- The battery must be stored with a full charge. A discharged battery can freeze sooner than a charged battery. A fully charged battery will store longer in cold temperatures than hot.
- Recharge the battery before returning to service. Although the tractor may start, the engine charging system may not fully recharge the battery.

HEAD LIGHT BULB REPLACEMENT

The tractor is equipped with headlights. If one of the bulbs should burn out, replace the bulb as follows:

- Fully raise the hood.
- Pull the wire harness plug from the bulb/socket assembly to unplug the wire harness. See Figure 36.

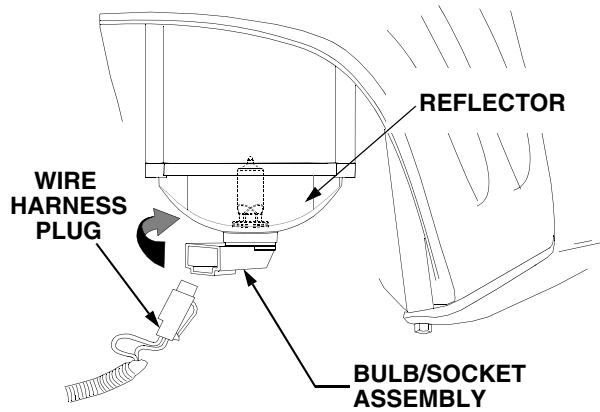

Figure 36

- Turn the bulb/socket assembly approximately a quarter turn counterclockwise to align its tabs with the notches of the reflector, then remove from the reflector.
- Replace with a new bulb/socket assembly (Cub Cadet No. 725-04084).
- Align the tabs of the new bulb/socket assembly with the notches of the reflector and insert the bulb.
- Turn the bulb/socket assembly clockwise to lock in place. Push the wire harness plug fully into the bulb socket.

HAZARD BULB REPLACEMENT

Hazard lights are installed on each side of the ROPS. The hazard lights may be either round or rectangular in shape. Replace the bulbs as follows:

- **Round Hazard Light ONLY** — Insert a **thin** bladed screwdriver, or similar tool, between an amber lense and the hazard light body, then twist to separate the lense from the body. Refer to Figure 37.
- **Rectangular Hazard Light ONLY** — Remove the two screws from either the front or rear amber lense; then slide the lense out of the body. Refer to Figure 37.
- Push the bulb inward and turn counterclockwise, then pull the bulb outward to remove from the light socket. See Figure 37.

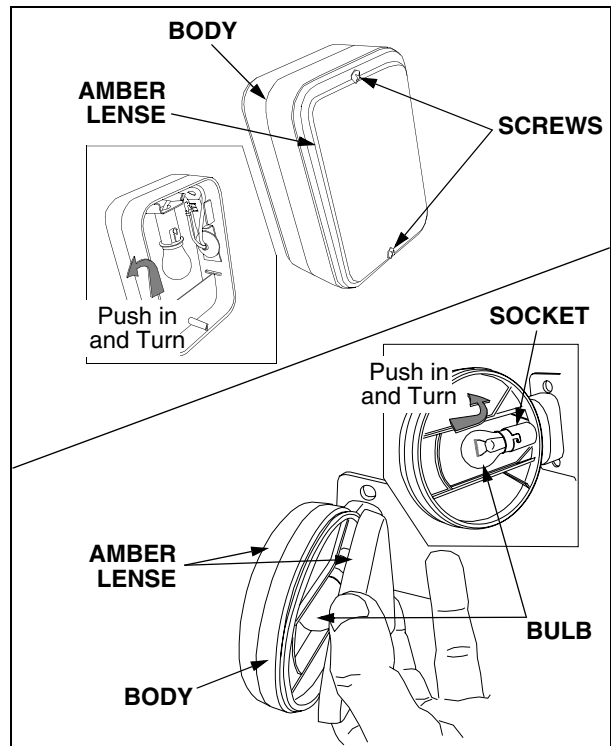

Figure 37

- Align the new bulb with the socket slot, push the bulb into the socket, and turn clockwise to lock it in the socket.
- **Round Hazard Light ONLY** — Position the lense on the hazard light body and push the lense onto the body until it snaps firmly into place on the body.
- **Rectangular Hazard Light ONLY** — Push the lense into the hazard light body and secure with the two screws.

SERVICING ELECTRICAL SYSTEM

Fuses are installed to protect the tractor's electrical system from damage caused by excessive amperage. Always use the same capacity fuse for replacement. If the electrical system does not function, check for blown fuses. See Figure 38.

If you have a recurring problem with blown fuses, have the tractor's electrical system checked by your Cub Cadet dealer.

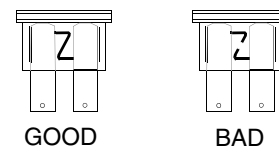

Figure 38

Main Fuse

The main fuse in the tractor wire harness protects the tractor's entire electrical system. A blown main fuse will prevent battery current from passing through the harness.

To replace the main fuse:

- Raise the tractor hood.
- Locate the main fuse under the dash panel, along the tractor's *right* frame rail. See Figure 39.

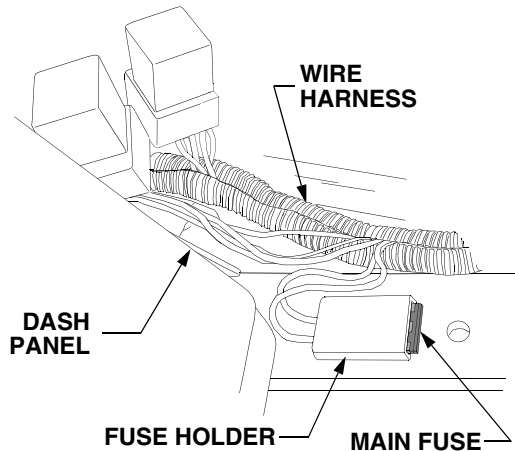

Figure 39

- Pull the fuse from the fuse holder and replace with the same capacity fuse (30 Amp). **NEVER use a higher amperage fuse.**
- Lower the tractor hood.

Accessing the Lower Dash Panel Area

Some electrical components are housed inside the lower dash panel. To access the area, remove the dash panel insert by removing the two screws. See Figure 40.

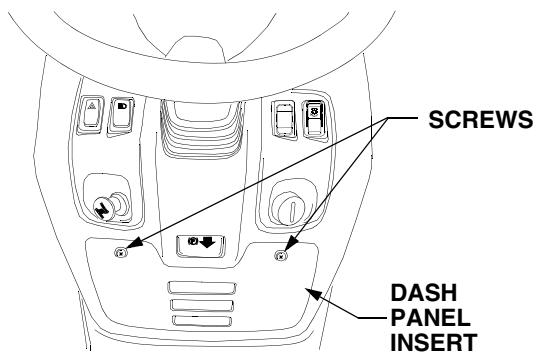

Figure 40

To reinstall the dash panel insert, hook the retaining lip at the bottom of the insert over the bottom edge of the dash opening, pivot the insert upward into position, and secure with the two screws.

Electrical Circuit Relays

Several relays, which operate electrical functions of the tractor, are located inside the lower dash panel. If one of the circuits is not functioning properly, have your dealer electrically check the relay. See Figure 41.

- Start Relay — Functions in the start circuit.
- PTO Relay — Operates in conjunction with both the Reverse Relay and Reverse Override Relay to engage the PTO.
- Reverse Relay — Functions with the PTO Relay and Reverse Switch in the "No Cut in Reverse" circuit.
- Reverse Override Relay — Functions with the Reverse Override Switch and PTO Relay to maintain PTO engagement when driving in reverse.
- Cruise Control Relay — This relay is installed at the factory for use with the optional Cruise Control Kit. The relay functions in the cruise control circuit, when the kit is installed.

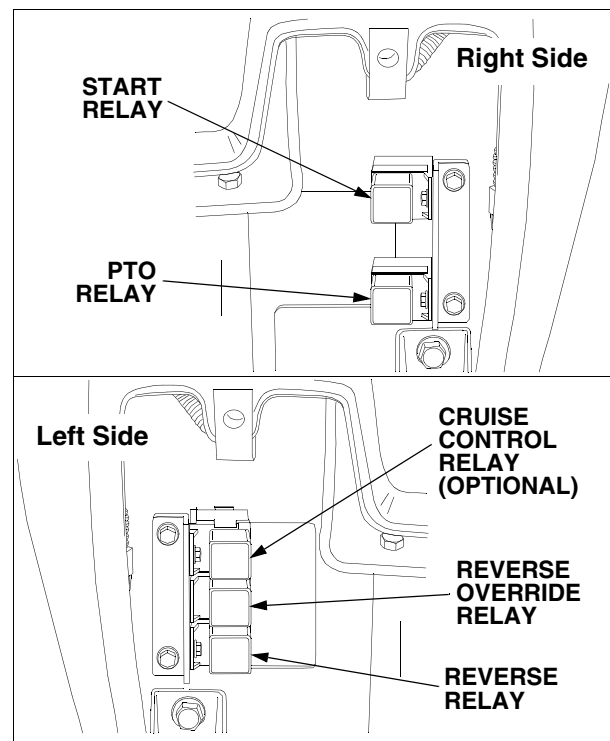

Figure 41

Hazard Light Flasher Relay

The flasher relay, which controls the on/off flashing of the hazard lights, is located inside the lower dash panel.

Replace the relay as follows:

- Pull the wire harness from the right side of the dash opening and remove the electrical tape from the flasher relay. Refer to Figure 42.

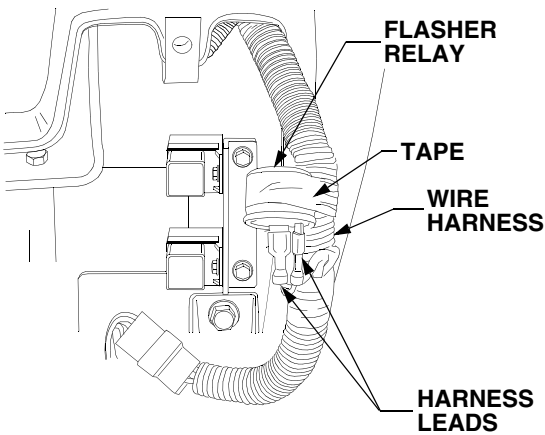

Figure 42

- Note the position of the two harness leads, then disconnect the leads and replace the faulty relay with a new relay. Secure the relay to the wire harness with electrical tape.
- Position the wire harness in the dash panel and reinstall the dash panel insert.

CHECKING TRANSMISSION/HYDRAULIC SYSTEM OIL LEVEL

Check the hydro transmission/hydraulic system oil level before each use. **NOTE:** Check the oil level only while the engine is stopped and the tractor is standing on a level surface.

The oil level sight glass is located in the rear of the transmission housing, just to the right of the rear PTO shaft. Refer to Figure 43.

The oil level is okay if oil can be seen through the sight glass. If the level is below the sight glass, oil must be added to the transmission as follows:

- Locate the oil fill plug on the upper right of the rear of the transmission housing. See Figure 43.

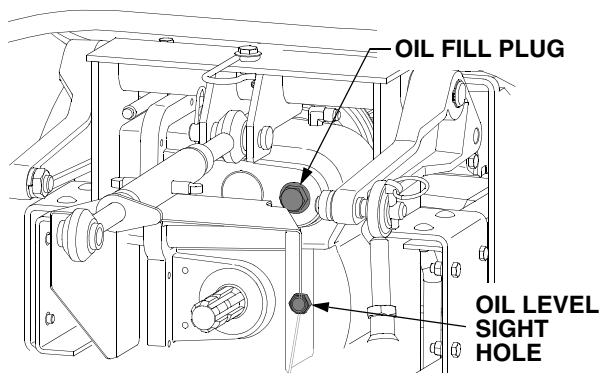

Figure 43

- Clean the area around the oil fill plug to prevent debris from entering the transmission housing.
- Turn the oil fill plug counterclockwise to unscrew from the transmission housing.
- Insert a funnel (preferably one with a flexible spout) into the fill hole of the transmission housing.
- Add Cub Cadet Drive System Plus oil until the oil level can be seen through the sight glass. Do not overfill the transmission.

IMPORTANT: Always use Cub Cadet Drive System Plus oil to ensure correct formulation. Substitute oils could affect performance and may cause damage to the transmission.

- Reinsert the oil fill plug into the transmission housing and turn clockwise until tight.

CHANGING THE HYDRO TRANSMISSION AND HYDRAULIC SYSTEM OIL FILTERS

With the exception of the first oil filter change after the 25 hour break-in period, the *hydraulic system oil filter* should be changed along with the transmission/hydraulic system oil after every 200 hours of operation. The *hydro transmission filter* should be changed after every 100 hours of operation.

25 Hour Break-In Period Filter Change

During the initial hours of tractor operation, contaminants caused by the normal break-in of internal transmission and hydraulic system components will collect in the oil filters. Because of this, both the hydro transmission and hydraulic system filters should be changed after the first 25 hours of operation.

Hydro Pump Filter — Part No. BS-492932S

Hydraulic System Filter — Part No. 723-3014

NOTE: If a front end loader, or a loader and backhoe, is installed on the tractor **after the first 25 hours** of operation, it is recommended that the filters again be changed after the first 25 hours of operation with these attachments installed.

Changing Hydro Transmission Oil Filter

The hydro transmission oil filter should be changed after the first 25 of tractor operation, and after every 100 hours operation.

- Stop the tractor engine and lower the mower deck or any other hydraulically lifted implement to the ground.
- Slide the seat fully forward; then tilt seat forward.

- Through the access hole in the rear fender, clean the area around the hydro transmission oil filter to prevent debris from entering the hydraulic system. Refer to Figure 44.
- Stuff shop rags underneath the hydro transmission filter to absorb any lost oil when the filter is removed. Refer to Figure 44.

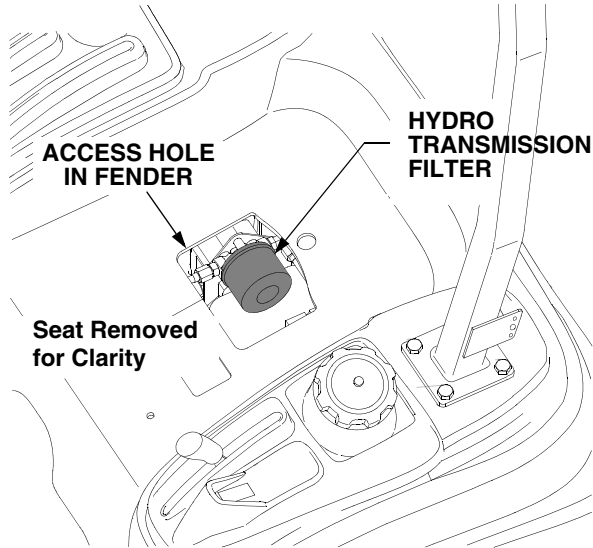

Figure 44

- Apply a light coating of clean transmission oil to the gasket of the new hydro transmission filter.
- Remove the old hydrostatic filter by turning it counterclockwise, and immediately replace with the new filter. Turn the filter clockwise by hand until the gasket contacts the filter base; then tighten the filter an additional 1/2 to 3/4 turn.
- Clean any residual oil from the top of the transmission.

Changing Hydraulic System Filter

The hydraulic system oil filter should be changed after the first 25 of tractor operation, and after every 200 hours operation.

- Stop the tractor engine and lower the mower deck or any other hydraulically lifted implement to the ground. **NOTE:** *To improve access to the hydraulic system filter, the mower deck should be removed from the tractor.*
- The hydraulic system oil filter is remotely mounted in the vertical position between the tractor frame rails. See Figure 45.
- Clean the area around the oil filter to prevent debris from entering the system.

- Position a suitable container below the hydraulic system filter. See Figure 45.

NOTE (25 Hour Break-In Filter Change Only): *Some oil may drain from the transmission when changing the hydraulic system oil filter. If collected in a **clean container and kept free of debris**, this oil may be reused in the transmission/hydraulic system.*

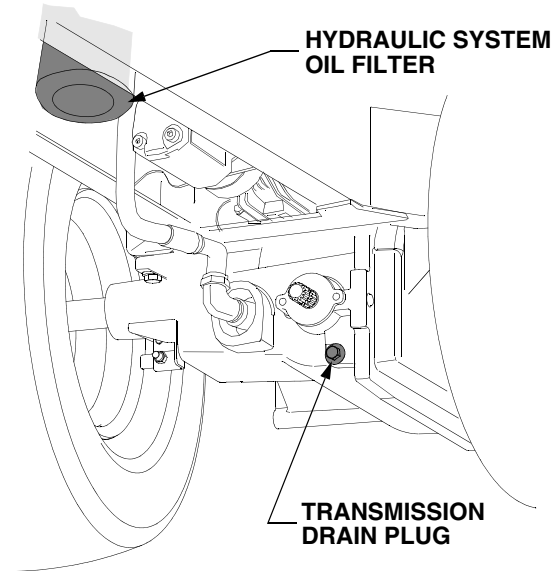

Figure 45

- Apply a light coating of clean transmission oil to the gasket of the new hydraulic system oil filter.

NOTE: *When performing the 25 hour break-in filter change, install the new filter as quickly as possible to minimize any loss of oil from the transmission.*

- From beneath the tractor frame, remove the old hydraulic system filter by turning it counterclockwise.
- When performing the 200 hour filter change, clean the oil filter adapter.
- Install the new filter. Turn the filter clockwise, by hand, until the gasket contacts the surface of the filter adapter; then tighten the filter an additional 1/2 to 3/4 turn.
- Clean the area around the transmission oil fill plug to prevent debris from entering the transmission (Refer to Figure 43) and remove the plug.

- Following the instructions previously provided in **CHECKING TRANSMISSION/HYDRAULIC SYSTEM OIL LEVEL**, refill the transmission with the clean salvaged oil or with new hydraulic oil.
- Reinsert the oil fill plug into the transmission housing and turn clockwise until tight.
- Start the engine and allow it to run for a few minutes. Shut the engine off, then check for leaks and recheck the oil level in the transmission housing.

CHANGING THE HYDRO TRANSMISSION AND HYDRAULIC SYSTEM OIL

Change the hydrostatic transmission/hydraulic system oil after every 200 hours of operation. The dry capacity of the transmission/hydraulic system is approximately 20 quarts.

Change the transmission/hydraulic system oil as follows:

- Operate the tractor for a short period to warm the oil to the normal operating temperature. Place the tractor on a level surface and engage the parking brake.
- Stop the tractor engine and lower the mower deck or any other hydraulically lifted implement to the ground. **NOTE:** *To improve access to the drain plug and hydraulic system filter, the mower deck should be removed from the tractor.*
- Clean the area around the transmission drain plug and the oil fill plug to prevent debris from entering the transmission. Refer to Figure 43 and Figure 45.
- Place a suitable container(s) beneath the front of the transmission housing.
- Remove the oil fill plug to help vent the transmission, then remove the drain plug and allow the transmission oil to drain into the container(s). Reinstall the drain plug after draining the oil. Refer to Figure 43 and Figure 45.



Dispose of used oil in an environmentally safe manner. If necessary, contact your area EPA office for proper disposal procedures and recycling center locations.

- Change the hydro transmission filter as instructed in **Changing Hydro Transmission Oil Filter**.
- Change the hydraulic system filter as instructed in **Changing Hydraulic System Oil Filter**.

- Insert a funnel (preferably one with a flexible spout) into the fill hole in the rear of the transmission housing.
- Pour Cub Cadet Drive System Plus oil into the transmission housing until the oil level can be seen through the sight glass. Do not overfill the transmission.

IMPORTANT: *Always use Cub Cadet Drive System Plus oil to ensure correct formulation. Substitute oils could affect performance and may cause damage to the transmission.*

- Reinsert the oil fill plug into the transmission housing and turn clockwise until tight.
- Start the engine and allow it to run for a few minutes. Shut the engine off, then check for leaks and recheck the oil level in the transmission housing.

LUBRICATION OF DRIVE SHAFT

Lubricate both ends of the drive shaft after every 50 hours of operation as follows:

- The front end of the drive shaft can be accessed from under the hood, and the rear end from beneath the tractor. **NOTE:** *It may be necessary to rotate the drive shaft to access the grease fittings.*
- Using a pressure lubricating gun, lubricate the drive shaft with Cub Cadet 251H EP grease.

LUBRICATION OF FRONT AXLE

Lubricate the front axle pivot pin, steering knuckles, and wheel hubs after every 10 hours of operation. See Figure 46. Using a pressure lubricating gun, lubricate the drive shaft with Cub Cadet 251H EP grease.

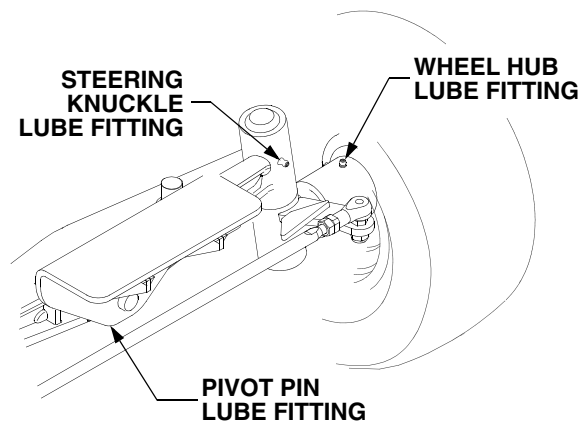

Figure 46

WHEEL LUG NUT TORQUE

The front wheel bolts and rear lug nuts should be retorqued after the first ten hours of operation and every 100 hours thereafter, or if the wheel assembly has been removed. Using a torque wrench, retighten the lug bolts and lug nuts as follows:

Rear Wheels—In a staggered pattern, retorque the rear wheel lug nuts to 60-70 ft. lbs.

Front Wheels—In a staggered pattern, retorque the front wheel lug bolts to 60-70 ft. lbs.

TIRE MAINTENANCE

Check the tire air pressure after every 50 hours of operation or weekly. Keep the tires inflated to the recommended pressures. Improper inflation will shorten the service life of a tire. See the tire side wall, or the Tire Inflation chart, for proper inflation pressures. Observe the following guidelines:

- Do not inflate a tire above the maximum pressure shown either on the sidewall of the tire or the Tire Inflation chart.
- Do not reinflate a tire that has been run flat or seriously under inflated. Have a qualified tire mechanic inspect and service the tire.



WARNING: Servicing tires can be dangerous. Whenever possible, trained personnel should service and mount tires.

If you must service the tires, observe the following safety precautions to avoid an injury or fatality:

- Make certain the rim is clean and free of rust.
- Lubricate the flanges of the rim and beads of the tire with soap solution.



WARNING: When seating the beads, never inflate a tire over 35 PSI. Inflating a tire with unseated beads beyond 35 PSI could break the bead or rim with sufficient explosive force to cause a serious injury.

- Inflate the tire to seat the beads. If the tire beads have not seated at or before 35 PSI, allow the tire to deflate. Reposition the tire on the rim, lubricate the tire beads and rim flanges, and reinflate until seated - up to a maximum of 35 PSI.

- After the beads have seated, adjust the inflation pressure to the recommended operating pressure.
- Do not use a damaged rim, or attempt to repair a rim by brazing, welding, or pounding out.
- Make certain the jack used to raise the tractor has a weight capacity adequate for lifting the tractor.
- Place the tractor on a firm, level surface and position jack stands to support the raised tractor while repairing tires.
- DO NOT place any part of your body beneath the tractor or start the tractor engine while the tractor is raised off the ground with a jack.

TIRE INFLATION CHART			
Position	Tread Type	Tire Size	Inflation Pressure
Front	Turf	18 x 8.5-8	15 psi
Rear	Turf	26 x 12-12	10 psi

MAINTENANCE OF THE ROLLOVER PROTECTIVE STRUCTURE (ROPS)

Periodically (at least every six months) visually inspect the ROPS for damage and loose fasteners. If damage is noted, contact your Cub Cadet dealer.

If an accident has occurred which may have damaged the ROPS, have the ROPS thoroughly inspected by your Cub Cadet dealer.



WARNING: To ensure the structural integrity of the ROPS to provide operator protection, do not attempt to straighten or weld the ROPS. A damaged ROPS should be replaced.

If the ROPS is removed for any reason, make sure the proper hardware is used to reinstall it, and that the recommended torque values are applied to the fasteners.

When replacing or reinstalling the ROPS, apply Loctite® 242 to the threads of the bolts and torque the bolts to 60 to 70 ft. lbs.

TRACTOR STORAGE

If your tractor is not going to be operated for an extended period of time (thirty days to approximately six months), the tractor should be prepared for storage. Store the tractor in a dry and protected location. If stored outside, cover the tractor (including the tires) to protect it from the elements. The procedures outlined below should be performed whenever the tractor is placed in storage.

1. Change the engine oil and filter following the instructions provided in **CHANGING THE ENGINE OIL AND FILTER** in **SECTION 5**.



WARNING: Never store the tractor with fuel in the tank indoors or in poorly ventilated enclosures, where fuel fumes may reach an open flame, spark or pilot light as on a furnace, water heater, clothes dryer, etc.



WARNING: Fuel left in the fuel tank deteriorates and will cause serious starting problems.

2. **If storing the tractor for 30 days or more:**
To prevent gum deposits from forming inside the engine's carburetor and causing possible malfunction of the engine, the fuel system must be either completely emptied, or the gasoline must be treated with a stabilizer to prevent deterioration.

Using a fuel stabilizer:

- Read the product manufacturer's instructions and recommendations.
- Add to clean, fresh gasoline the correct amount of stabilizer for the capacity (approximately 6 gallons) of the fuel system.
- Fill the fuel tank with treated fuel and run the engine for 2-3 minutes to get stabilized fuel into the carburetor.

Emptying the fuel system:

- Prior to putting the tractor in storage, monitor fuel consumption with the goal of running the fuel tank empty.
 - If a large volume of fuel is left-over, the fuel line can be disconnected at the fuel filter and the leftover fuel drained into an approved container.
 - Run the engine until it begins to stall. Use the choke to keep the engine running until all fuel in the carburetor has been exhausted.
3. Clean the engine and the entire tractor thoroughly.
 4. Fully charge the battery, then disconnect the negative cable at the battery to prevent possible discharge. Recharge the battery periodically when in storage.

NOTE: Remove the battery if exposed to prolonged periods of sub-freezing temperatures. Store in a cool, dry location where temperatures are above freezing.

5. Lubricate all lubrication points.
6. Jack up and block the tractor to remove the weight from the tires if stored for a long period. If not blocked up, reinflate the tires regularly.

NOTE: We do not recommend the use of a pressure washer or garden hose to clean your tractor. They may cause damage to electrical components; spindles; pulleys; bearings; or the engine. The use of water will result in shortened life and reduce serviceability.

REMOVING THE TRACTOR FROM STORAGE

- Check the engine oil.
- Fully charge the battery and inflate the tires to the recommended pressure.
- Start the engine and allow to idle for a few minutes to ensure engine is operating properly.
- Drive the tractor without a load to make certain all the tractor systems are functioning properly.

SECTION 5: ENGINE INFORMATION AND MAINTENANCE

KOHLER CO. FEDERAL AND CALIFORNIA EMISSION CONTROL SYSTEMS LIMITED WARRANTY SMALL OFF-ROAD EQUIPMENT ENGINES

The U.S. Environmental Protection Agency (EPA), the California Air Resources Board (CARB), and Kohler Co. are pleased to explain the Federal and California Emission Control Systems Warranty on your small off-road equipment engine. For California, engines produced in 1995 and later must be designed, built and equipped to meet the state's stringent anti-smog standards. In other states, 1997 and later model year engines must be designed, built and equipped, to meet the U.S. EPA regulations for small non-road engines. The engine must be free from defects in materials and workmanship which cause it to fail to conform with U.S. EPA standards for the first two years of engine use from the date of sale to the ultimate purchaser. Kohler Co. must warrant the emission control system on the engine for the period of time listed above, provided there has been no abuse, neglect or improper maintenance.

The emission control system may include parts such as the carburetor or fuel injection system, the ignition system, and catalytic converter. Also included are the hoses, belts and connectors and other emission related assemblies.

Where a warrantable condition exists, Kohler Co. will repair the engine at no cost, including diagnosis (if the diagnostic work is performed at an authorized dealer), parts and labor.

MANUFACTURER'S WARRANTY COVERAGE

Engines produced in 1995 or later are warranted for two years in California. In other states, 1997 and later model year engines are warranted for two years. If any emission related part on the engine is defective, the part will be repaired or replaced by Kohler Co. free of charge.

OWNER'S WARRANTY RESPONSIBILITIES

- (a) The engine owner is responsible for the performance of the required maintenance listed in the owner's manual. Kohler Co. recommends that you retain all receipts covering maintenance on the engine, but Kohler Co. cannot deny warranty solely for the lack of receipts or for your failure to assure that all scheduled maintenance was performed.
- (b) Be aware, however, that Kohler Co. may deny warranty coverage if the engine or a part has failed due to abuse, neglect, improper maintenance or unapproved modifications.
- (c) For warranty repairs, the engine must be presented to a Kohler Co. service center as soon as a problem exists. Call 1-800-544-2444, or access our web site at: www.kohlerengines.com, for the names of the nearest service centers. The warranty repairs should be completed in a reasonable amount of time, not to exceed 30 days.

If you have any questions regarding warranty rights and responsibilities, you should contact Kohler Co. at 1-920-457-4441 and ask for an Engine Service representative.

COVERAGE

Kohler Co. warrants to the ultimate purchaser and each subsequent purchaser that the engine will be designed, built and equipped, at the time of sale, to meet all applicable regulations. Kohler Co. also warrants to the initial purchaser and each subsequent purchaser, that the engine is free from defects in material and workmanship which cause the engine to fail to conform with applicable regulations for a period of two years.

Engines produced in 1995 or later are warranted for two years in California. For 1997 and later model years, EPA requires manufacturers to warrant engines for two years in all other states. These warranty periods will begin on the date the engine is purchased by the initial purchaser. If any emission related part on the engine is defective, the part will be replaced by Kohler Co. at no cost to the owner. Kohler Co. is liable for damages to other engine components caused by the failure of a warranted part still under warranty.

Kohler Co. shall remedy warranty defects at any authorized Kohler Co. engine dealer or warranty station. Warranty repair work done at an authorized dealer or warranty station shall be free of charge to the owner if such work determines that a warranted part is defective.

Listed below are the parts covered by the Federal and California Emission Control Systems Warranty. Some parts listed below may require scheduled maintenance and are warranted up to the first scheduled replacement point for that part. The warranted parts are:

- Carburetor assembly
- Throttle body (EFI system - if equipped)
- Catalytic muffler (if equipped)
- Fuel metering valve (if equipped)
- Crankcase breather
- Fuel pressure regulator (EFI system - if equipped)
- Ignition module(s) with high tension lead
- Spark advance module (if equipped)
- Oxygen, speed, throttle position, and temperature sensors (if equipped)
- Electronic control unit (if equipped)
- Fuel injectors (EFI system - if equipped)
- Air filter, fuel filter, and spark plugs (only to first scheduled replacement point)

LIMITATIONS

This Emission Control System Warranty shall not cover any of the following:

- (a) repair or replacement required because of misuse or neglect, improper maintenance, repairs improperly performed or replacement not conforming to Kohler Co. specifications that adversely affect performance and/or durability and alterations or modifications not recommended or approved in writing by Kohler Co.,
- (b) replacement of parts and other services and adjustments necessary for required maintenance at and after the first scheduled replacement point,
- (c) consequential damages such as loss of time, inconvenience, loss of use of the engine or equipment, etc.,
- (d) diagnosis and inspection fees that do not result in eligible warranty service being performed, and
- (e) any add-on or modified part, or malfunction of authorized parts due to the use of add-on or modified parts.

MAINTENANCE AND REPAIRS REQUIREMENTS

The owner is responsible for the proper use and maintenance of the engine. Kohler Co. recommends that all receipts and records covering the performance of regular maintenance be retained in case questions arise. If the engine is resold during the warranty period, the maintenance records should be transferred to each subsequent owner. Kohler Co. reserves the right to deny warranty coverage if the engine has not been properly maintained; however, Kohler Co. may not deny warranty repairs solely because of the lack of repair maintenance or failure to keep maintenance records.

Normal maintenance, replacement or repair of emission control devices and systems may be performed by any repair establishment or individual; however, **warranty repair must be performed by a Kohler authorized service center.** Any replacement part or service that is equivalent in performance and durability may be used in non-warranty maintenance or repairs, and shall not reduce the warranty obligations of the engine manufacturer.

ENGINE MAINTENANCE



WARNING: Use care when servicing any component in the engine area. If the engine has recently been operated, components will be hot and could cause burns. Allow the engine to cool before servicing.



WARNING: Before servicing the engine, place the tractor on a level surface, stop the engine, engage the parking brake, and remove the key from the ignition switch. For additional safety, remove the spark plugs to prevent accidental starting.

CLEANING THE ENGINE

This tractor has an air-cooled engine. Air must be able to circulate freely over the cooling fins of the cylinders and cylinder heads. Keep the area between the engine baffles and cylinders free of accumulated dirt and debris to prevent engine overheating, which could possibly cause extensive engine damage.



WARNING: Keep the muffler area clean. Before running the engine, remove all combustible debris from the muffler area.

CHECKING ENGINE OIL LEVEL

Before each use, the oil level in the engine crankcase should be checked to see that it is filled to the correct level. Close monitoring of the engine oil level during the first 10 hours of operation is especially important. The oil level should be checked hourly during the first 10 hours of operation.

- Check the oil level only while the engine is stopped and the tractor is level. Clean the area around the oil level dipstick to prevent debris from entering the crankcase. See Figure 47.
- If recently operated, allow the engine to cool and the oil to drain back into the oil pan.
- To check the oil level, withdraw the dipstick and wipe it clean; then insert the dipstick all the way into the tube before withdrawing it for a true reading. See Figure 47.

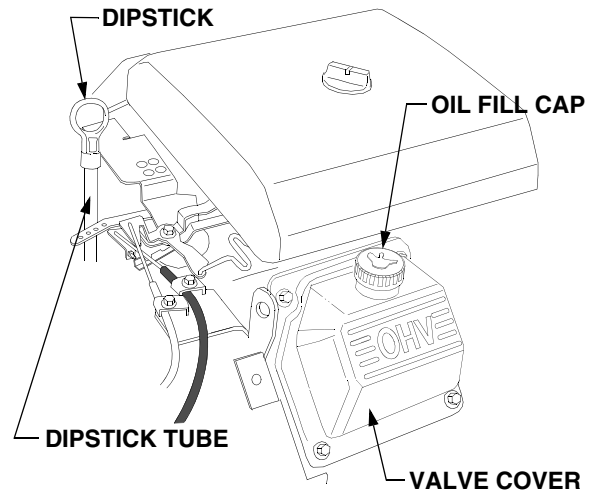

Figure 47

- Always keep the oil level between the 'F' (full) and the 'L' (add) marks on the dipstick. See Figure 48.
- Reinsert the dipstick into the dipstick tube and push firmly into the tube.

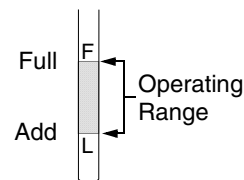

Figure 48

ADDING ENGINE OIL



WARNING: Never overfill the engine crankcase. The engine may overheat and/or damage may result if the crankcase is below the "ADD" mark or over the "FULL" mark on the dipstick. For best results, fill to the "FULL" mark on the dipstick as opposed to adding a given quantity of oil. Always check the level on the dipstick before adding more oil.

Refer to the LUBRICATION TABLE in the **MAINTENANCE SECTION** of this manual to determine the proper type of oil to add to the crankcase for the conditions under which the engine will be operated.

- Place the tractor on a level surface and engage the parking brake. Stop the tractor engine and remove the ignition key.
- Clean the area around the oil filler cap to prevent debris from entering the crankcase. Refer to Figure 47.
- Turn the oil filler cap a quarter turn counterclockwise to remove from the *right* valve cover.
- SLOWLY pour oil into the crankcase until the oil level reaches the “FULL” mark on the dipstick. Refer to Figure 48.
- Insert the oil fill cap into the valve cover and turn clockwise until fully tightened. Reinsert the dipstick into the dipstick tube and push firmly into the tube.

IMPORTANT: *The oil fill cap and dipstick must always be installed securely in place when the engine is running. Severe engine damage could result from failure to do so.*

CHANGING THE ENGINE OIL AND FILTER



WARNING: Because the engine is run prior to draining the oil, the engine may be hot. Use caution to avoid burning yourself on engine surfaces.

The engine oil and oil filter should be changed after every 100 hours of operation. Refer to the LUBRICATION TABLE in the **MAINTENANCE SECTION** of this manual for the quantity of oil needed, and to determine the proper type of oil to use for the conditions under which the engine will be operated.

Run the engine for a few minutes to allow the oil in the crankcase to warm up. Warm oil will flow more freely and carry away more engine impurities. Use care to avoid burns from hot oil. While the engine oil is warm, proceed as follows:

- Place the tractor on a level surface and engage the parking brake. Stop the tractor engine and remove the ignition key.
- Clean around the base of the oil filter, the oil filler cap, and the dipstick tube to prevent debris from entering the crankcase.
- Remove the dipstick and oil fill cap from the engine. Refer to Figure 49.
- Locate the engine drain valve on the rear of the engine (See Figure 49). Place a suitable container below the open end of the drain valve to collect the old oil.

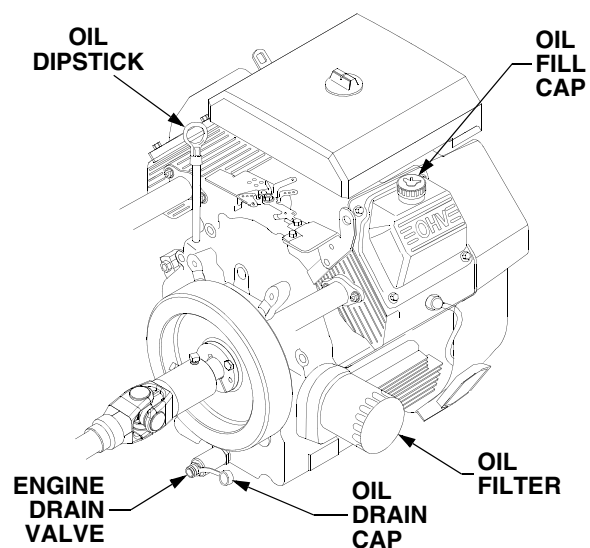

Figure 49

- Pull the oil drain cap off the end of engine drain valve. To prevent loss of the cap, do not remove the cap's retaining ring from the drain valve. See Figure 49.
- Push the engine drain valve slightly inward; then turn counterclockwise until it stops. Pull the valve outward to open the valve and drain the oil from the engine.
- Allow the old oil to completely drain from the engine crankcase into the container below.
- Remove the filter by turning it counterclockwise using an automotive type filter wrench to loosen. See Figure 49.
- Push the drain valve fully inward until you are able to turn the valve clockwise to lock in the closed position. Refer to Figure 49.
- Clean any oil from the end of the drain valve and push the cap onto the valve.
- To assure a continuous flow of oil to all critical lubrication points within the engine, pour some new oil into the treaded center hole of the filter and allow time for the oil to be absorbed into the filter material.
- Apply a light coating of clean oil on the gasket of the new oil filter. Thread the filter on by hand until the gasket contacts the filter mounting surface, then tighten the filter an additional 2/3 to 1 turn.
- Refill the crankcase to the "FULL" mark on the dipstick with the appropriate type oil.
- Reinstall the oil fill cap and dipstick.

- Start the engine and run for about 3 minutes. Stop the engine and check for leaks at the oil filter and drain valve.
- Recheck the oil level and, if needed, add oil to bring the oil level up to the "FULL" mark.



WARNING: Never overfill the engine crankcase. The engine may overheat and/or damage may result. For best results, fill to the "FULL" mark on the dipstick as opposed to adding a given quantity of oil. Always check the level on the dipstick before adding more oil.



Dispose of used oil in an environmentally safe manner. If necessary, contact your area EPA office for proper disposal procedures and recycling center locations.

IMPORTANT: The oil fill cap and dipstick must always be installed securely in place when the engine is running. Severe engine damage could result from failure to do so.

SERVICING OIL COOLER

Inspect and clean the oil cooler, located next to the oil filter, after every 100 hours of operation.

Clean debris from the fins of the oil cooler with a brush or compressed air.

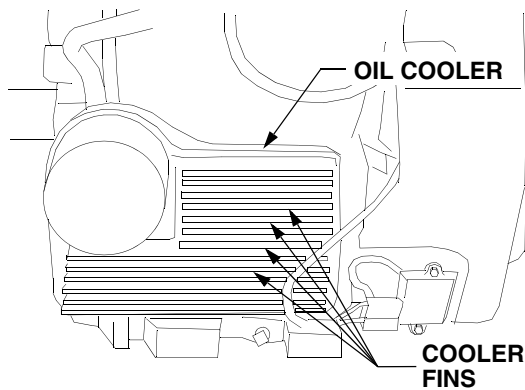

Figure 50

- Recheck the coolant level in the overflow reservoir and refill as needed. Reinstall the reservoir cap.

CHANGING THE AIR CLEANER

Check the air cleaner daily or before starting the engine. Check for loose or damaged components and check the condition of the filter element. Remove any buildup of dirt and debris in the air cleaner cover.

See Figure 51 for assembly of the air cleaner elements.



WARNING: Operating the engine with loose or damaged air cleaner components will allow unfiltered air into the carburetor, causing extensive wear and eventual failure of the engine.

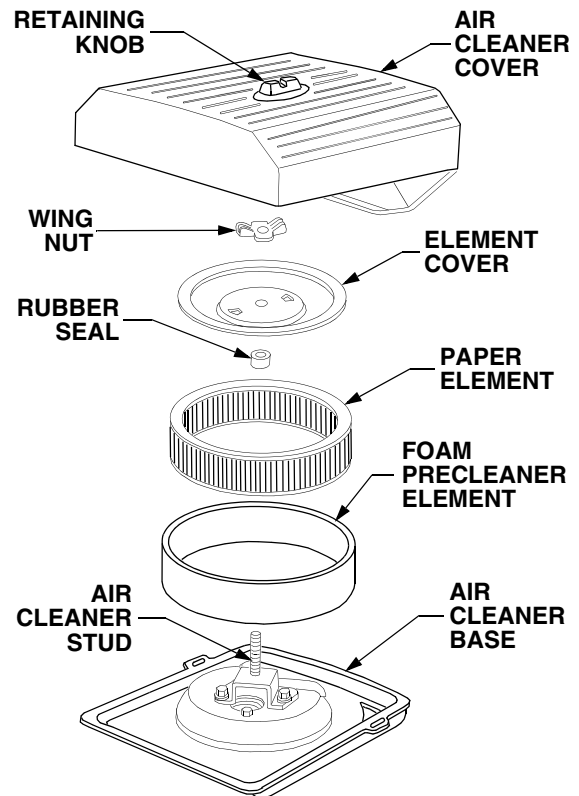

Figure 51

SERVICING THE FOAM PRECLEANER

Wash the foam precleaner every 25 hours of operation. Wash more often when operating under extremely dusty conditions. Replace the precleaner if torn or otherwise damaged.

Wash the precleaner as follows (Refer to Figure 51):

- Loosen the cover retaining knob and lift off the air cleaner cover.
- Remove the foam precleaner by carefully slipping it up off the paper element.
- Wash the precleaner in warm water with detergent. Rinse the precleaner thoroughly to remove all traces of the detergent. Squeeze out (do not wring) excess water in a dry cloth. Allow the precleaner to air dry.
- Saturate the precleaner with clean engine oil, then squeeze out all excess oil.
- Carefully slip the precleaner fully onto the paper element.
- Reinstall the air cleaner cover and secure with the retainer knob.

SERVICING THE PAPER ELEMENT

Replace the paper air cleaner element after every 100 hours of operation. Replace the element more often if operating the tractor under extremely dusty conditions. Refer to Figure 51.

- Loosen the cover retaining knob and lift off the air cleaner cover.
- Remove the wing nut and lift off the element cover. Lift out the paper air cleaner element with precleaner.
- Remove the foam precleaner by carefully slipping it off the paper element.
- Check the paper element for excessive dirt, paper tears, or damage to the seal on the bottom of the element. Replace a dirty or damaged paper element. Do not use pressurized air to clean the paper element.
- When servicing the air cleaner, also inspect the air cleaner base and the rubber seal for any type of damage. Replace if damaged.
- Slip the precleaner fully onto the paper element and reinstall the paper element onto the air cleaner base.
- Install the element cover and secure with the wing nut.
- Reinstall the air cleaner cover and secure with the retainer knob.

IMPORTANT: *Properly cleaned and installed air cleaner elements significantly contribute to prolonging engine life.*

SERVICING THE SPARK PLUGS



WARNING: To avoid possible injury, be sure the engine is off and has cooled before making any adjustments or repairs.

Check the spark plugs after every 100 hours of operation. Replace with new plugs if necessary. See your authorized dealer for the correct replacement spark plugs (Pt. No. 759-3336).

- Disconnect the spark plug wires and remove all dirt from around the spark plug before removing.

- Use a spark plug wrench to remove spark plugs.
- Clean carbon deposits from the electrodes using a soft wire brush.
- Inspect for cracked porcelain or any other wear or damage. Replace with a new spark plug if necessary.
- Check the gap of the spark plugs. The gap must be .030 inch (0.76mm). Reset if necessary.

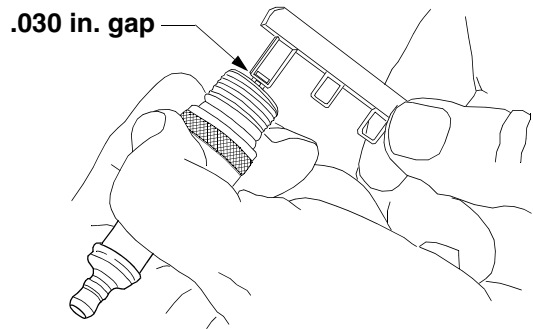

Figure 52

- Reinstall the spark plugs and torque to 18 ft-lbs. Connect the spark plug wires.

CHANGING THE FUEL FILTER



WARNING: Do not replace the fuel filter when tractor is hot. Allow the tractor to cool before separating the fuel lines.

The tractor is equipped with an in-line fuel filter. The fuel filter can be accessed from underneath the tractor along the left side of the tractor frame, just forward of the fuel tank.

The fuel filter cannot be disassembled. Consequently you must visually inspect the filter periodically. Inspect for a build-up of residue inside the filter body, and for a dirty element which can be indicated by discoloration. Replace the fuel filter when dirty.

SECTION 6: SPECIFICATIONS

Engine

Manufacturer	Kohler
Horsepower	25
Cylinders	2 OHV
Cooling System	Air Cooled
Bore	3.27 in. (83 mm)
Stroke	2.64 in. (67 mm)
Displacement	44.0 cu. in. (725 ml)
Compression Ratio	9.0:1
Low Idle Speed	1500 ± 75 rpm
High Idle Speed	3600 rpm
Valves	Hydraulic Lifters
Spark Plug Gap	.030 in. (0.76 mm)
Crank Case Capacity (With Filter)	2.1 qts. (2.0 L)

Electrical System

Charging System	Flywheel-Coil
Capacity	20 Amp Regulated
Battery	12 Volt / 500 cca
Starter Motor	Solenoid Shift

Fuel System

Fuel Tank Capacity	5.6 gal. (21.1 L)
Fuel Type	Unleaded Gasoline
Fuel Filter	In-line
Fuel Pump	Electrical

Transmission

Type	Hydrostatic
Drive	2WD
Oil	Cub Cadet Drive System Plus Fluid
Capacity (Includes Hydraulics)	5.0 gal. (18.9 L)
Shift Range	Hi/Lo
Forward Travel Speed	
Hi Range	Forward — 0 to 8.0 mph Reverse — 0 to 4.0 mph
Lo Range	Forward — 0 to 4.0 mph Reverse — 0 to 2.0 mph
Differential Lock	Foot Pedal Control

SPECIFICATIONS

Hydraulic Lift System

Type Auxiliary Pump
Control Fender Mounted Lever
Pump Capacity 5.5 gal./min.
Maximum Pressure 1500 psi

Brakes

Type External Dual Disc
Parking Brake Hand Operated Lever

Steering

Type Hydrostatic Power
Turning Radius 30 in.

Power Take-Off

Type Electric Clutch
Speed
Rear 540 rpm
Mid/Front (Optional) 2000 rpm
Shaft Size
Rear 1.375 in. (35 mm)
Mid 1.0 in (25.4 mm)
Horse Power at PTO 20

Tires

Turf-Front 18 x 8.5-8
Turf-Rear 26 x 12-12

General Dimensions

Overall Length (w/o Hitch) 85 in.
Overall Length (w/Hitch) 103 in.
Overall Width 45 in.
Overall Height (w/o ROPS) 51 in.
Overall Height (w/ROPS) 79 in.
Wheelbase 55 in.
Minimum Ground Clearance 5 in.
Weight w/ROPS 1200 lbs.

SECTION 7: OPTIONAL EQUIPMENT AND ACCESSORIES

When purchasing your tractor, you probably had it equipped for your particular needs at that time. You may later wish to obtain additional equipment or accessories to perform other tasks. Refer to the chart below for a list of approved optional equipment and accessories currently available through your *Cub Cadet* dealer.

DESCRIPTION	MODEL NUMBER
Front End Loader ⁽¹⁾⁽⁶⁾	590-812-100
Front End Loader Mountin Kit	590-813-100
Front Hitch Kit ⁽²⁾	590-817-100
54" Mower Deck ⁽⁵⁾	590-810-100
60" Mower Deck ⁽⁵⁾	590-811-100
Mower Deck Mounting Kit	590-842-100
Tractor Cab	590-824-100
48" Snow Thrower ⁽³⁾	590-818-100
PTO Kit - Front ⁽⁴⁾	590-816-100
Hydraulic Valve Kit	590-841-100
42" Rotary Tiller ⁽⁶⁾	590-669-100
60" Finish Mower ⁽⁶⁾	590-819-100
Front Weight Bracket/Bumper	590-821-100
60" Dozer Blade ⁽⁴⁾	590-615-100
60" Rear Blade ⁽⁶⁾	590-626-100
48" Box Blade ⁽⁶⁾	590-627-100
Post Hole Digger ⁽⁶⁾	590-628-100
60" Rake ⁽⁶⁾	590-632-100
Angle Kit	590-623-100
Rear Weight Box	590-836-100
Canopy	590-835-100
Cruise Control Kit	759-04077
Transmission Oil Heater Kit	759-04039

(1) Requires hydraulic valve kit 590-841-100 and 590-813-100 loader mounting kit

(2) Requires hydraulic valve kit 590-841-100

(3) Requires front hitch kit 590-817-100 and front PTO kit 590-816-100.

(4) Requires front hitch kit 590-817-100

(5) Requires mounting kit 590-842-100

(6) See TRACTOR WEIGHTING in SECTION 2: OPERATION



**LIMITED WARRANTY
FOR CUB CADET COMPACT TRACTORS
AND CUB CADET ATTACHMENTS**

Proper maintenance of your Cub Cadet equipment is the owner's responsibility. Follow the instructions in your owner's manual for correct lubricants and maintenance schedule. Your Cub Cadet dealer carries a complete line of genuine Cub Cadet parts and quality lubricants and filters for your equipment's engine, transmission, chassis and attachments.

This limited warranty covers any defect in materials or workmanship in your Cub Cadet compact tractor and Cub Cadet attachments from the date of purchase for the first user purchaser.

COMPACT TRACTOR (less the power line) ONE YEAR OR 1500 HOURS (whichever is first)

POWER LINE:

NON-COMMERCIAL TWO YEARS OR 1500 HOURS (whichever is first)

COMMERCIAL ONE YEAR OR 1500 HOURS (whichever is first)

BATTERY ONE YEAR PRORATED WITH 100% REPLACEMENT
DURING THE FIRST 3 MONTHS

CUB CADET ATTACHMENTS ONE YEAR

Commercial use is defined as either having hired operators or used for income producing purposes. In no event will we be responsible for loss of use, loss of profit, loss of or damage to crops, inconvenience, commercial loss or other incidental or consequential damages whatsoever.

The power line is defined as (and is limited to):

- | | |
|--|----------------------------------|
| Cylinder Block | Transmission Case or Center Case |
| Cylinder Head | Differential Housing |
| (Front) Gear Case | Final Drive Case |
| Oil Pan | Front Axle Case |
| Clutch Housing and all Parts Contained Therein | Mid and Rear PTO Output Shafts |

We will replace or repair any part or parts without charge through your Authorized Cub Cadet Compact Tractor Dealer.

ITEMS NOT COVERED

The warranty does not cover routine maintenance items such as lubricants, filters (oil, fuel, air and hydraulic), cleaning, tune-ups, brake and/or clutch inspection, adjustments made as part of normal maintenance, blade sharpening, set-up, abuse, accident and normal wear. It does not cover incidental costs such as transporting your equipment to and from the dealer, telephone charges or renting a product temporarily to replace a warranted product. Specific items not covered are: lamp bulbs, injection nozzles, fuel injection pumps, glow plugs, strainers, fuses, brake linings, clutch facings, clutch discs, coolant, rubber products, glass products, plastic products, packings, belts and damage caused by use in an application for which the product is not designed or any other misuse, neglect, incorporation or use of unsuitable attachments or parts, unauthorized alteration, improper installation, or any causes other than defects in material or workmanship of the product.

There is no other express warranty.

HOW TO OBTAIN SERVICE

Contact your authorized Cub Cadet servicing dealer who sold you your Cub Cadet equipment. If this dealer is not available, see the Consumer Yellow Pages under "lawn mowers" for the name of a dealer near you.

If you need further assistance in finding an authorized Cub Cadet servicing dealer, contact:

**CUB CADET LLC
POST OFFICE BOX 361131
CLEVELAND, OHIO 44136-0019**

HOW DOES STATE LAW APPLY?

This limited warranty gives you specific legal rights, and you may also have other rights which vary from state to state.

CHANGES

Cub Cadet LLC reserves the right to make changes in the design and other changes in its products at any time without notice and without incurring any obligation to product previously manufactured or purchased.