

Attachment C1: CTX-1000 System

TECHNICAL MANUAL

OPERATION AND MAINTENANCE INSTRUCTIONS

OPERATIONAL LEVEL

**EXCITER,
DIGITAL SIGNAL PROCESSING,
SINGLE,
MF - HF**

**T-4150
&
T-4180**



Cubic Communications Inc.
9535 Waples Street
San Diego, California 92121-2953

Telephone: (619) 643-5800 Telefax: (619) 643-5803

Manual Part No. 2607-1021-1

Revision B
Change 2

1 November 1997
29 January 1998



RECORD OF CHANGES

CHANGE	DATE	TITLE OF BRIEF DESCRIPTIONS	ENTERED BY
1	1 Nov 97	Engineering update. Pages changed are as follows: Title Page, Record of Changes, 2-7, 3-45 thru 3-47, 4-1, 8-1/(8-2 blank), & FP-9/FP-10(blank)	CCI Eng. Dept.
2	29 Jan 98	Customer comments. Pages changed are as follows: Title Page, Record of Changes, iv, 1-4, 2-3. FO-3, Annex A, & Annex B	CCI Eng Dept.



FOREWORD

SCOPE

This manual contains information to obtain best performance from the T-4150/80 exciter. The information includes: a general description of the equipment, preparation for use and installation instructions, operating instructions, general theory of operation, maintenance instructions, preparation for reshipment, storage, and parts list.

PROPRIETARY DATA

Information contained in this document is the property of Cubic Communications, Inc. This information may not be disclosed to a third party, either wholly or in part, without the written consent of Cubic Communications, Inc.

CORRECTION NOTICE

Information contained in this document is believed to be correct as of the publication date. If a variation is noted between the information in this manual and the equipment in your possession, contact the factory for clarification. Future issues will be updated if necessary.

RIGHTS RESERVED

Cubic Communications, Inc. reserves the right to change the specifications, design details, and method of fabrication of the equipment at any time without notice.

RIGHTS RESERVED

The T-4150/80-9 when use with the PS-7130A and PA-5050A comprises the CTX-1000 System. This system is FCC certified for aeronautical base station usage. FCC identification number is NVSCTX-1000.



TABLE OF CONTENTS - Cont.

<u>Chapter</u>	<u>Page</u>	<u>Chapter</u>	<u>Page</u>
Section II. REMOTE CONTROL	3-34	4 GENERAL THEORY OF OPERATION	4-1
3-8 REMOTE OPERATION USING SERIAL BUS.	3-34	4-1 INTRODUCTION	4-1
3-8.1 <i>Serial Bus Description</i>	3-34	4-2 BLOCK DIAGRAM DISCUSSION.	4-1
3-8.2 <i>Serial Bus Message Format</i>	3-34	4-2.1 <i>AC Receptacle/RFI Filter</i>	4-1
3-8.3 <i>Serial Bus Message Types</i>	3-34	4-2.2 <i>AC Line Filter</i>	4-1
3-8.3.1 <i>Serial Bus Command Messages</i>	3-34	4-2.3 <i>Power Supply Module</i>	4-1
3-8.3.1.1 <i>Serial Bus Exciter Command Messages</i>	3-34	4-2.4 <i>Front Panel</i>	4-1
3-8.3.1.2 <i>Serial Bus Interface Command Messages</i>	3-34	4-2.4.1 <i>Main Adjustment Knob</i>	4-1
3-8.3.2 <i>Serial Bus Status Messages</i>	3-34	4-2.4.2 <i>Keypad Board</i>	4-1
3-8.3.2.1 <i>Serial Bus Exciter Status Messages</i>	3-34	4-2.4.3 <i>Display Module</i>	4-1
3-8.3.2.2 <i>Serial Bus Interface Status Messages</i>	3-36	4-2.5 <i>Digital Module</i>	4-1
3-8.4 <i>Serial Bus Message Protocol</i>	3-36	4-2.5.1 <i>Control Section</i>	4-1
3-8.4.1 <i>Serial Bus Normal Mode</i>	3-36	4-2.5.2 <i>DSP Section</i>	4-2
3-8.4.2 <i>Serial Bus Acknowledge Mode</i>	3-36	4-2.6 <i>Serial Bus (Optional)</i>	4-2
3-8.5 <i>Line Driver Operation</i>	3-36	4-2.6.1 <i>Serial Bus Remote Interface Board</i>	4-2
3-8.6 <i>Broadcast Address</i>	3-36	4-2.6.2 <i>Serial Bus Cable Assembly</i>	4-3
3-8.7 <i>Serial Bus Message Definition</i>	3-36	4-2.7 <i>IEEE-488 Bus (Optional)</i>	4-3
3-9 REMOTE OPERATION USING IEEE-488 BUS.	3-48	4-2.7.1 <i>IEEE-488 Remote Interface Board</i>	4-3
3-9.1 <i>IEEE-488 Bus Description</i>	3-48	4-2.7.2 <i>IEEE-488 Cable Assembly</i>	4-3
3-9.2 <i>Device Capabilities</i>	3-48	4-2.8 <i>Synthesizer Module</i>	4-3
3-9.3 <i>Talking and Listening</i>	3-48	4-2.8.1 <i>Control</i>	4-3
3-9.4 <i>SRQ and Serial Poll Response</i>	3-50	4-2.8.2 <i>Reference Frequency</i>	4-3
3-9.5 <i>Device Clear And Selected Device Clear Response</i>	3-50	4-2.8.3 <i>3rd LO Generation</i>	4-3
3-10 POWER UP AND TESTING CONSIDERATIONS	3-50	4-2.8.4 <i>Audio</i>	4-3
3-11 EEPROM CLEARING	3-51	4-2.9 <i>RF Analog Module</i>	4-4
		4-2.9.1 <i>First Mixer</i>	4-4
		4-2.9.2 <i>1ST LO/DSP Clock</i>	4-4
		4-2.9.3 <i>Second Mixer</i>	4-4
		4-2.9.4 <i>Second LO Driver</i>	4-4
		4-2.9.5 <i>Third Mixer</i>	4-4
		4-2.9.6 <i>Third LO Driver</i>	4-4
		4-2.9.7 <i>Postselector</i>	4-4

TABLE OF CONTENTS - Cont.

<u>Chapter</u>	<u>Page</u>	<u>Chapter</u>	<u>Page</u>
5 MAINTENANCE INSTRUCTIONS	5-1		
Section I. PREVENTIVE MAINTENANCE	5-1	5-6.5 <i>Digital Module</i>	5-6
5-1 INTRODUCTION	5-1	5-6.6 <i>Remote Control Board (optional)</i>	5-7
5-2 CLEANING AND LUBRICATION	5-1	5-6.7 <i>Keypad Board</i>	5-7
5-3 INSPECTION	5-1	5-6.8 <i>Keypad</i>	5-7
5-3.1 <i>External Inspection</i>	5-1	5-6.9 <i>Display Module</i>	5-7
5-3.2 <i>Internal Inspection</i>	5-1	5-6.10 <i>Main Adjustment Knob</i>	5-7
5-4 PERFORMANCE VERIFICATION	5-1	5-6.11 <i>Optical Shaft Encoder</i>	5-7
Section II. CORRECTIVE MAINTENANCE	5-3	5-6.12 <i>Fan Assembly</i>	5-8
5-5 TROUBLESHOOTING	5-3	5-6.13 <i>Support Handles</i>	5-8
5-5.1 <i>Troubleshooting Philosophy</i> ...	5-3	5-7 SOFTWARE UPLOADING	5-8
5-5.2 <i>Built-In Tests</i>	5-3	6 PREPARATION FOR RESHIPMENT	6-1
5-5.2.1 <i>POST</i>	5-3	6-1 INTRODUCTION	6-1
5-5.2.2 <i>BITE</i>	5-3	6-2 DISASSEMBLY AND REMOVAL	6-1
5-5.2.3 <i>BIT</i>	5-3	6-3 PACKAGING	6-1
5-5.3 <i>Troubleshooting Procedure</i> ...	5-4	6-4 SHIPPING	6-1
5-5.3.1 <i>Fault Identification</i>	5-4	7 STORAGE	7-1
5-5.3.2 <i>Initial Checks</i>	5-4	7-1 INTRODUCTION	7-1
5-5.3.3 <i>Front Panel Display Interpretation</i>	5-4	7-2 STORAGE ENVIRONMENT	7-1
5-5.3.4 <i>Signal Tracing</i>	5-4	7-3 PRESERVATION	7-1
5-6 SUBASSEMBLY REMOVAL AND REPLACEMENT	5-6	8 PARTS LIST	8-1
5-6.1 <i>Synthesizer Module</i>	5-6	8-1 INTRODUCTION	8-1
5-6.2 <i>RF Analog Module</i>	5-6	8-2 REPLACEABLE PARTS LISTING	8-1
5-6.3 <i>Power Supply Module</i>	5-6	ANNEX TO T-4150/80	AN1
5-6.4 <i>AC Line Filter Board</i>	5-6	A OPERATING BY EMISSION DESIGNATORS	AN-1A
		B DC POWER SUPPLY OPTION	AN-1B

LIST OF ILLUSTRATIONS

<u>Figure</u>		<u>Page</u>
1-1A	T-4150 Front View	1-0
1-1B	T-4180 Front View	1-0
2-1A	T-4150 Rear View	2-2
2-1B	T-4180 Rear View	2-2
2-2	Power Connector (J1) Pin Descriptions	2-3
3-1	Front Panel Controls and Display	3-2
3-2	Parameter Entry Controls and Display	3-3
3-3	Normal Display.	3-4
3-4	Data Entry Display.	3-4
3-5	Meter Display.	3-4
3-6	Meter/ISB Display.	3-4
3-7	Soft Key Menus Overall Flow Diagram	3-6
3-8	Serial Bus Message Format	3-35
3-9	Serial Bus Character Format	3-35
3-10	IEEE-488 Serial Poll Response Byte	3-51
FO-1A	T-4150 Outline and Mounting Drawing	FP-1
FO-1B	T-4180 Outline and Mounting Drawing	FP-5
FO-2	T-4150/80 Block Diagram	FP-7
FO-3	T-4150/80 Interconnect Diagram	FP-9
FO-4	T-4150/80 Motherboard Schematic	FP-11
FO-5A	T-4150 Replaceable Parts Locator Diagram	FP-15
FO-5B	T-4180 Replaceable Parts Locator Diagram	FP-19

LIST OF TABLES

<u>Table</u>	<u>Page</u>
1-1 T-4150/80 Specifications	1-2
1-2 Items Furnished	1-6
1-3 Recommended Tools and Test Equipment (Or Equivalent)	1-6
2-1 Rear Panel Connections	2-3
2-2 Serial Remote Control Bus Connector (J4) Pin Descriptions	2-4
2-3 IEEE-488 Remote Control Bus Connector (J4) Pin Descriptions	2-6
2-4 PA CONTROL Connector (J5) Pin Description	2-7
2-5 AUDIO Connector (J6) Pin Descriptions	2-7
3-1 Front Panel Controls And Display	3-2
3-2 Parameter Entry Controls	3-3
3-3 Modulation Modes Description	3-10
3-4 Serial Bus Interface Command Messages	3-37
3-5 Serial Bus Interface Status Messages	3-37
3-6 Exciter Command and Status Messages	3-38
3-7 IEEE-488 Bus Management Signals	3-49
3-8 IEEE-488 Bus Handshake Lines	3-49
3-9 IEEE-488 Implemented Interface Capabilities	3-49
5-1 Fault Detectors	5-3
5-2 Front Panel Fault Messages	5-4
8-1 Replaceable Parts.	8-1

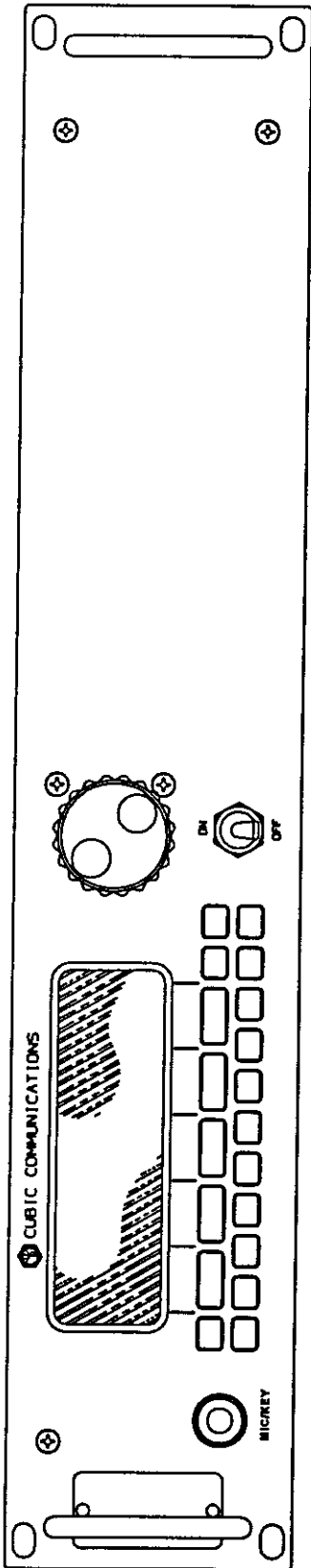

Figure 1-1A T-4150 Front View.

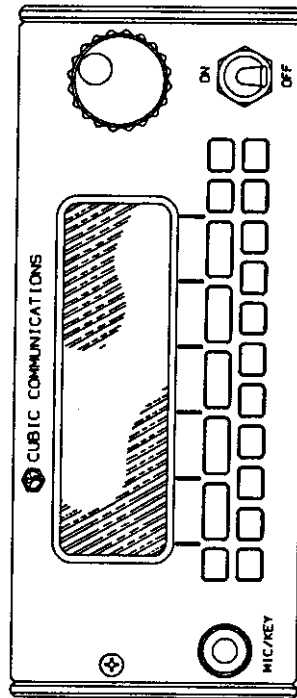

Figure 1-1B T-4180 Front View.

CHAPTER 1 GENERAL DESCRIPTION

1-1 INTRODUCTION.

This chapter contains an equipment description, equipment supplied and required, storage data, tools and test equipment, and a summary of safety precautions.

1-2 EQUIPMENT DESCRIPTION.

The T-4150/80 (figure 1-1) is a multi-mode digital signal processing (DSP) exciter with a frequency range from 1.6 to 30 MHz.

The exciter contains individually shielded modules mounted in an 8½ by 3½-inch desktop chassis. Two T-4180 exciters may be fastened together (using an optional dual rack-mount kit) to construct a standard 19-inch rack-mount configuration.

The exciter is controlled by a 19-button keypad and main adjustment knob used to select the exciter parameters. Five "soft keys" work in conjunction with the vacuum fluorescent digital display immediately above the soft keys.

In addition to soft key selections, the vacuum fluorescent digital display provides a variety of data including channel, modulation mode, frequency, bandwidth, gain, local/remote control, an RF level meter, and an AF level meter. Additional information is displayed depending on soft key selections.

By proper selection of parameters, the exciters can generate a wide variety of signals. These include: on/off keyed (CW), amplitude modulation (AM), upper sideband (USB), upper sideband - full carrier (USBfc), upper sideband - partial carrier (USBpc), lower sideband (LSB), lower sideband - full carrier (LSBfc), lower sideband - partial carrier (LSBpc), independent sideband (ISB) (suppressed carrier and independent), frequency shift keyed (FSK), frequency modulation (FM), and frequency modulation facsimile (FMfax).

The selected audio input is provided on a 600 ohm balanced line. Normal and alternate (LSB audio when ISB is selected) audio are simultaneously input on separate 600 ohm balanced lines.

A MIC/KEY jack on the front panel provides for connection of an external microphone or CW key. The audio level is automatic. The audio is automatically applied to the correct modulator depending on the modulation mode. However, when ISB modulation is

selected, microphone audio is directed to the normal audio channel only.

Either an internal or external reference frequency may be used. The external reference frequency is automatically sensed and used when connected to the rear panel.

The exciters may be remotely controlled by any suitable bus controller using either an RS-232, or RS-422 serial interface bus, or an IEEE-488 parallel interface bus.

1-3 SPECIFICATIONS.

Refer to table 1-1 for specifications of the equipment.

1-4 EQUIPMENT FURNISHED.

Table 1-2 lists the items furnished, items required but not furnished, and optional items.

1-5 STORAGE DATA.

Refer to Chapter 7 for storage data.

1-6 TOOLS AND TEST EQUIPMENT.

Table 1-3 lists recommended tools and test equipment for operational level maintenance. There are no special tools or test equipment required.

1-7 SAFETY PRECAUTIONS.

Safety precautions are presented in this manual preceded by the word **WARNING** or **CAUTION** just prior to the point where the hazard is likely to be encountered. Warnings and cautions are defined as follows:

WARNING

Refers to a procedure or practice that, if not correctly followed, could result in injury, death, or long term health hazard.

CAUTION

Refers to a procedure or practice that, if not correctly followed, could result in equipment damage or destruction.

Table 1-1 T-4150/80 Specifications.

Item	Specification
FREQUENCY	
Tuning Range	1.6 to 30 MHz
Tuning Step Size	1 Hz through 1 MHz in decade steps
Tuning Accuracy	Internal Standard (TCXO): 1 ppm of tuned frequency External Standard: Equal to accuracy of external standard in ppm Internal/External Frequency Standard: 10 MHz
Synthesizer Tuning Speed	$\Delta f < 100 \text{ kHz} < 1.0\text{ms}$ typical $\Delta f < 1 \text{ MHz} < 1.5\text{ms}$ typical $\Delta f < 10 \text{ MHz} < 2.0\text{ms}$ typical
MODULATION MODES (Emission Designators)	CW (A1A, A1B) AM (A2A, A2B, A3E) USB, LSB (J2A, J2B, J3E) USBfc, LSBfc (H2A, H2B, H3E) USBpc, LSBpc (R2A, R2B, R3E) ISB (B8E) FSK (F1A, F1B) FMfax (F1C) FM (F3C) (Bandwidth may be automatically selected by modulation mode and modulation characteristic).
DISPLAY	Full graphics vacuum fluorescent display
HOP & DWELL	
Channels	250 programmable channels stored in nonvolatile memory
Hop	Up to 250 channels
Rate	10 to 5000 milliseconds/channel
Adjustable Level	-33 to +27 dBm in 1 dB increments
RF SECTION	
Exciter Power Output	+27 dBm maximum
Output Impedance	50 ohms
Output VSWR	2:1 maximum
RF On/Off Switching Speed	< 80 μ sec 60 dB isolation, controlled by external TTL levels
Postselection	Eight suboctave bandpass postselector filters used from 1.6 to 30 MHz.
Phase Noise	Per MIL-STD-188-141A, Paragraph 5.2.5 and Figure 3 fixed site, non-cosited
Phase Stability	Exceeds MIL-STD-188-141A, Paragraph 5.2.4
Absolute Delay	5 ms maximum

Table 1-1 T-4150/80 Specifications-Cont.

Item	Specification
Noise and Distortion	In-band Noise: -105 dBc/Hz. In-band Intermodulation Distortion (IMD): 50 dB below either tone of two equal signals producing +21 dBm PEP
Spurious Broadband Emissions	Per MIL-STD-188-141A, Paragraph 5.3.2.1 and Table II Harmonic Outputs: -65 dBc maximum All Other Discrete Spurious: -80 dBc
Carrier Suppression	-60 dBc for a single tone at +27 signal output
Keying Characteristics	Attack Time Delay: 3 ms maximum to 90 percent of full steady state output Release Time Delay: 3 ms maximum to 10 percent of full steady state output Keying Time: Defined as time from "key down" to RF output or "key up" to reduce RF output
Modulation Input Characteristics	Unbalanced Audio Input Impedance: 150 ohms \pm 10 percent over 500 to 7000 Hz passband Audio Input Level: -45 to -15 dBm ref. 150 ohms Balanced Audio Input Impedance: 600 ohms, 0 dBm nominal Audio Level Control: Automatic audio level control holds PEP audio at standard level \pm 1 dB over the 30 dB input range FM deviation up to 5 kHz Amplitude Modulation up to 95%
INPUT/OUTPUTS	
Audio Line Input (Normal)	600 ohms balanced pair on audio connector 0 dBm \pm 3 dB (Normal is the USB when ISB modulation mode is selected).
Audio Line Input (Alternate)	600 ohms balanced pair on audio connector 0 dBm \pm 3 dB. (Alternate audio is LSB when ISB modulation mode is selected)
MIC	20mV p-p nominal, 150 ohm input impedance to front panel mic jack. Mic key in parallel with rear panel audio connector keyline.
Reference In	10 MHz, 0 dBm, 50 ohms nominal.
RF Output	+27 dBm max. into 50 ohms. Optimum spurious outputs are obtained for output levels of +21 dBm to +27 dBm. When the optional power amplifier requires drive of less than +21 dBm, the insertion of a suitable external attenuator is recommended.
RF On/Off	TTL Level or open collector (LOW = off; HIGH or open = on)
MANUAL LEVEL CONTROL (MLC)	-33 to +27dBm (nominal) in 1 dB steps.
IF SECTION	
1st IF	24 kHz. DSP generated, lowpass filter @ 80 kHz
2nd IF	456 kHz. Standard Filter BW = 18 kHz
3rd IF	40.456 MHz. Standard Filter BW = 22.5 kHz

Table 1-1 T-4150/80 Specifications-Cont.

Item	Specification
RF/IF Filters	IF Filters: Fifty-one DSP-derived FIR filters provides bandwidths from 100 Hz to 16 kHz automatically by modulation mode and modulation characteristics. Eight suboctave bandpass filters at the RF output to reduce harmonic content.
REMOTE CONTROL	IEEE-488, RS-232 and RS-422 available
BITE	Fault isolation to the module level
POWER REQUIREMENTS	90 - 260 VAC, 47 - 440 Hz, 60 VA (80 VA max @ 400Hz input) switching mode power supply.
RELIABILITY	MTBF: 15,000 hours Note: 1) All calculated failure rates are based on the environmental stress factor of "Naval Sheltered" (NS) as defined in MIL-HDBK-217F. 2) All failure rates are based on the part count method defined in MIL-HDBK-217F.
MAINTAINABILITY	Mean-Time-to-Repair (MTTR) of not more than 30 minutes at the module replacement level
CONTROLS AND CONNECTORS	
Front Panel	Full alphanumeric display with full function keypad for entry of all parameters Control knob for selection of all numeric parameters Power switch: toggle type 1/4 inch phone jack for microphone and/or key line input
Rear Panel	Power Connector: T-4150: Circular locking connector T4180: IEC RF Output: BNC External Frequency Standard Input: BNC Audio Input: 15 pin Sub D PA Control: 15 pin Sub D Bus Control: 25 pin Sub D for RS-232, RS-422; 24 pin stacking connector for IEEE--488
GENERAL DATA	
Dimensions	8.45" (21.45 cm) wide, 3.5" (8.8 cm) high, 22.25" (56.47 cm) deep
Weight	Approx 16.0 lbs. (7.26 kg) (Unpackaged)
ENVIRONMENTAL DATA	
Temperature Range	0 to +50°C Operating, -40 to +85°C Storage.
EMI/EMC	Equipment designed to intent of the applicable requirements of MIL-STD 461/462 as a guide

Table 1-1 T-4150/80 Specifications-Cont.

Item	Specification
DESIGN AND CONSTRUCTION	
Workmanship	MIL-E-16400, Paragraph 3.17 as a guideline
Interchangeability	All identical units, assemblies, and replacement parts are physically, electrically and functionally interchangeable
FINISH	
Front Panel & Chassis Cover	FED-STD-595 chip 26307, semi-gloss grey enamel
Chassis	Corrosion protected following guidelines established in Paragraph 3.4 of MIL-E-16400
Handles and Silkscreen Markings	Matte black
OPTIONS	
High-performance reference oscillator	OCXO, 0.1 ppm of tuned frequency
Serial Data Bus	RS-232 or RS-422
Parallel Data Bus	IEEE-488
Dual Rack Mount Kit	Hardware and slides to fasten two T-4180 exciters together for installation in standard 19-inch rack

Table 1-2 Items Furnished.

Part No.	Nomenclature	Furn./Optl.
260701-XX ¹	T-4150/80 MF - HF Digital Exciter	Furn.
696-012	AC power cord	Furn.
2607-1021-1	Technical manual	Furn.
2600-1009-1	Rack Mount Kit, Dual (for T-4180 only)	Optl. Not furnished
324-009/324-010	Audio Connector/Hood (cable end)	Optl. Not furnished
324-070/324-010	PA Control Connector/Hood (cable end)	Optl. Not furnished

¹XX indicates model number and factory installed options. Refer to identification plate on equipment.

Table 1-3 Recommended Tools and Test Equipment (Or Equivalent).

Part No.	Nomenclature	Manufacturer
-	Screwdriver, Phillips 6 inch, No. 1	Any
-	Screwdriver, Phillips 6 inch, No. 2	Any
-	Driver, nut, 1/4 inch	Any
-	Wrench, open end, 3/16 inch	Any
-	Wrench, open end, 1/2 inch	Any
-	Wrench, Allen, 1/16 inch	Any
-	Wrench, Allen, 7/64 inch	Any
465B	Oscilloscope	Tektronix
8050A	Digital multimeter (true RMS)	Fluke
HP5381A	Frequency counter	Hewlett Packard
355D	Coaxial Attenuator	Hewlett Packard
HP8568B	Spectrum analyzer ¹	Hewlett Packard
4421	RF Wattmeter ¹	Bird

¹Optional

CHAPTER 2 PREPARATION FOR USE AND INSTALLATION INSTRUCTIONS

2-1 INTRODUCTION.

This chapter contains unpacking, inspection, installation, connections, and initial alignment procedures.

2-2 UNPACKING AND INSPECTION.

To unpack and inspect the exciter for damage, perform the following procedures:

WARNING

Do not drop the equipment when lifting or carrying. Personnel injury or equipment damage may occur.

1. Inspect the shipping carton for damage before unpacking the exciter.

NOTE

If the carton is damaged, open the carton in the presence of a shipping carrier agent if possible. If damage is found after the exciter is unpacked, retain the carton and packing materials for inspection.

2. Open the carton and remove the foam packing material on top of the exciter.
3. Lift the exciter from the carton.

NOTE

Save carton for possible reshipment.

4. Inspect the exciter for external damage including dents and scratches.

CAUTION

Do not attempt to operate the exciter if major damage is found.

2-3 INSTALLATION.

The exciter is designed for desktop operation in a relatively dust free environment with an ambient temperature range between 0 and +50°C. An optional dual rack mount kit is available for the T-4180 to mount two units into a standard 19-inch rack. No special tools or additional materials are required for installation.

NOTE

See figure FO-1 for clearance requirements and mounting details.

2-4 CONNECTIONS.

Refer to table 2-1 and connect the output, power cable, and optional equipment to the unit. (See figure 2-1).

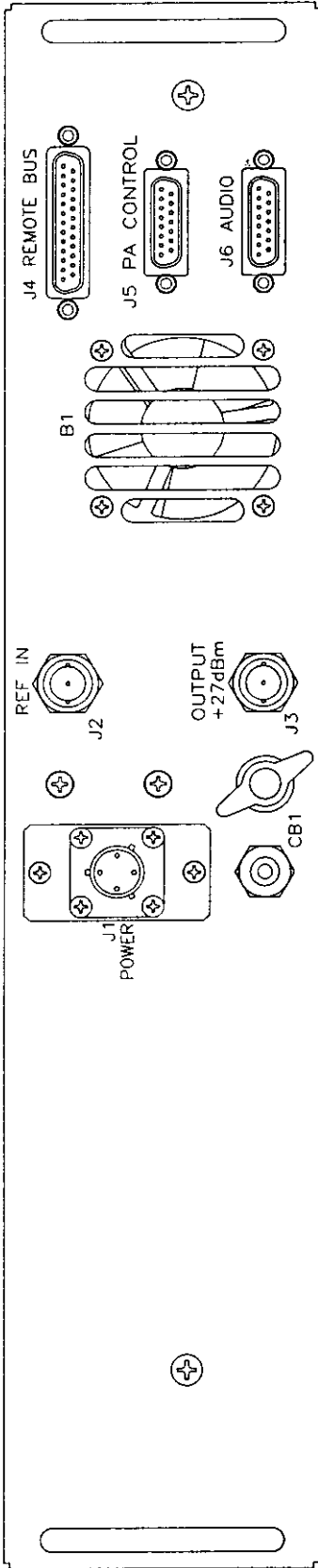

Figure 2-1A T-4150 Rear View.

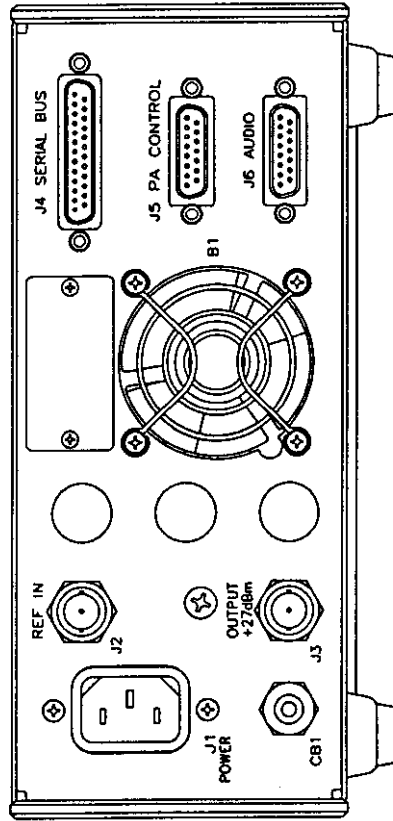

Figure 2-1B T-4180 Rear View.

Table 2-1 Rear Panel Connections.

Name	Type	Mating Type	Description
T-4150 POWER (J1)	MS3122A10-4P (344-426)	G6F10-4SNH (Burdy) also 4ea. rm20m-13d28 pins reqrd.	90 to 260 VAC, 47 to 440 Hz, single phase 60 VA (80 VA max @ 400 Hz input). Figure 2-2 shows the pin descriptions.
T-4180 POWER (J1)	IEC 320-C-13 (343-002)	NEMA 5-15P (696-012, Power Cord)	90 to 260 VAC, 47 to 440 Hz, single phase 60 VA (80 VA max @ 400 Hz input).. Figure 2-2 shows the pin descriptions.
REF IN (J2)	BNC Jack (344-246)	BNC Plug (Customer Option)	Reference frequency in. Used to connect 10 MHz external frequency standard. 50 ohms. 0 dBm.
OUTPUT +27 dBm (J3)	BNC Jack (344-246)	BNC Plug (Customer Option)	Coaxial output connection. Impedance is approximately 50 ohms with a VSWR less than 3 to 1 at the exciter tuned frequency. Optimum spurious outputs are obtained for output levels of +21 dBm to +27 dBm. When the optional power amplifier requires drive of less than +21 dBm, the insertion of a suitable external attenuator is recommended.
SERIAL REMOTE CONTROL (J4) (Opt)	25-pin female D subminiature connector.	25-pin male D subminiature connector. (Customer Option)	(Optional daughter board in Digital module, and cable assembly must be installed). For external RS-232C or RS-422 remote control bus operation. Table 2-2 lists the pin descriptions. Refer to para 3-7.5.2.2.1 to set the serial bus configuration.
IEEE-488 REMOTE CONTROL (J4) (Opt)	IEEE-488 24-pin "blue ribbon" connector assy.	Standard IEEE-488 24-pin connector. (Customer Option)	(Optional daughter board in Digital module, and cable assembly must be installed). For external remote control bus operation. Table 2-3 lists the pin descriptions. Refer to para 3-7.5.2.2.2 to set the IEEE-488 bus address.
PA CONTROL (J5)	15-pin "D" subminiature male (324-009)	15-pin "D" subminiature female (324-070)	Used to connect external power amplifier. Table 2-4 lists the pin descriptions.
AUDIO (J6)	15-pin "D" subminiature female (324-070)	15-pin "D" subminiature male (324-009)	Used to connect audio from line inputs or other equipment. Table 2-5 lists the pin descriptions.

NOTE: Part numbers in parenthesis (000-000) indicate CCI part number if applicable.

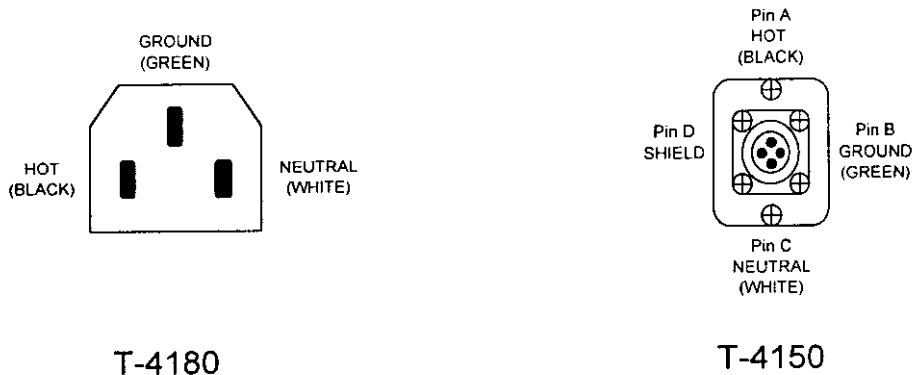

Figure 2-2 Power Connector (J1) Pin Descriptions.

Table 2-2 Serial Remote Control Bus Connector (J4) Pin Descriptions.

Pin	Signal	Remarks	Bus
2	TXD	Transmitted Data	RS-232
3	RXD	Received Data	RS-232
4	RTS	Request to Send	RS-232
5	CTS	Clear to Send	RS-232
7	GND	Signal Ground	RS-232
12	RSA	Request to Send A	RS-422
13	RSB	Request to Send B	RS-422
14	SDA	Send Data A	RS-422
15	SDB	Send Data B	RS-422
16	RDA	Receive Data A	RS-422
17	RDB	Receive Data B	RS-422
23	CSA	Clear to Send A	RS-422
24	CSB	Clear to send B	RS-422

NOTE: The pinout for the RS-232 interface follows the recommendations of the EIA standard. Since the EIA standard for RS-422 does not call out recommended pin assignments, these circuits are assigned to unused pins on the same connector as the RS-232 circuits.

Only one set of signals (RS-232 or RS-422) is active at any given time. Selection is made at the front panel of the exciter. The name "Transmitted Data" for RS-232 is synonymous with "Send Data" for RS-422. All circuits for the RS-422 interface consist of a differential pair of signal lines labeled A and B. Both lines must be connected to the circuit at the other end, A to A and B to B.

An exciter configured with the serial interface will operate as Data Terminal Equipment (DTE). This means that the circuits named Transmitted Data and Request to Send are outputs from the exciter and the circuits named Received Data and Clear to Send are inputs to the exciter. The electrical characteristics of the interface will conform to either EIA standard RS-232-C or EIA standard RS-422-A with the following exceptions.

When so configured from the front panel of the exciter, the line drivers associated with the Transmitted Data and Request to Send circuits for the unit will be in a high impedance state except when that unit has been commanded by the system controller to transmit. When done transmitting, the line drivers will return to the high impedance state. This feature, referred to as bus sharing or party line operation, allows multiple exciters to share a single circuit for the Transmitted Data signal to the system controller. In systems where only one exciter is connected to the external controlling device, this feature may be disabled from the exciter front panel.

(CONT)

Table 2-2 Serial Remote Control Bus Connector (J4) Pin Descriptions-Cont.

NOTE (CONT):

The Request to Send (RTS) and Clear to Send (CTS) handshake circuits are generally not used when the line drivers are configured for bus sharing operation. When the line drivers are not configured for bus sharing, the operation of the CTS and RTS lines is as follows: When an exciter is ready to accept remote control commands it will set the RTS circuit true. When it has received a message and is processing the commands, it will set the RTS circuit false until it is ready to receive another command. The exciter will only transmit messages to an external device when its CTS circuit is held true by the external device. The external device may stop the transmitted output of the exciter (to prevent buffer overflow for example) by taking the CTS circuit false. When the CTS circuit is again taken true, the exciter will begin transmitting where it left off. **NOTE:** When bus sharing is enabled from the exciter front panel, the state of the CTS circuit is ignored.

The number of T-4100 series exciters that may be connected to a single controller is dependent on the serial bus type and the line driver characteristics of the controller, but in general is at least 10 exciters for RS-232 operation and at least 30 exciters for RS-422 operation. Dual chassis models count as two exciters. The input resistance of the RS-232 line exciters is approximately 5000 Ohms. The exciter contains no termination resistors for the RS-422 bus.

If connected directly to a computer interface also configured as DTE, a reversal of transmit and receive data (TXD and RXD or SD and RD) and request to send and clear to send (RTS and CTS or RS and CS) lines may be necessary. The Request to Send and Clear to Send lines may be jumpered together on the mating connector if required by the system. These reversals or jumpers are normally not required if units are connected through a modem. If a T-4100 series exciter is to be connected to another DTE device as its controller, the circuits must be swapped for proper operation as follows:

<u>T-4100 Series Exciter</u>		<u>Other DTE Device</u>
Transmitted Data	----->-----	Received Data
Received Data	-----<-----	Transmitted Data
Request to Send	----->-----	Clear to Send
Clear to Send	-----<-----	Request to Send
Signal Ground	-----	Signal Ground

CAUTION: Refer to note below EEPCLR command in table 3-5.

Table 2-3 IEEE-488 Remote Control Bus Connector (J4) Pin Descriptions.

Pin	Signal	Remarks
1	D1	Data Bit 1
2	D2	Data Bit 2
3	D3	Data Bit 3
4	D4	Data Bit 4
5	EOI	End Or Identify (Bus management)
6	DAV	Data Valid (Handshake)
7	NRFD	Not Ready For Data (Handshake)
8	NDAC	Not Data Accepted (Handshake)
9	IFC	Interface Clear (Bus management)
10	SRQ	Service Request (Bus management)
11	ATN	Attention (Bus management)
12	SHIELD	-
13	D5	Data Bit 5
14	D6	Data Bit 6
15	D7	Data Bit 7
16	D8	Data Bit 8
17	REN	Remote Enable (Bus management)
18	GND 6	Twisted with pin 6
19	GND 7	Twisted with pin 7
20	GND 8	Twisted with pin 8
21	GND 9	Twisted with pin 9
22	GND 10	Twisted with pin 10
23	GND 11	Twisted with pin 11
24	LOGIC GND	Signal common

NOTE: Cable requirements for the IEEE-488 bus are determined by the actual system design. Refer to the hardware installation instructions provided with the Bus Controller. The bus cables may be configured in either a star or daisy-chain. Any combination of the two configurations may be used provided the total cable length does not exceed 20 meters (65.5 feet) or 2 meters (6.5 feet) for each bus device connected, whichever is less. The IEEE-488 bus connector on the rear panel is the type specified in the IEEE-488-1978 standard and uses metric studs. Make sure the locking devices are engaged on all connectors in the system.

Table 2-4 PA CONTROL Connector (J5) Pin Description.

Pin	Signal	Remarks
1	NU	Not used
2	NU	Not used
3	GND	Ground
4	NU	Not used
5	PA KEY/	Output line - Open drain pull-down to ground (40V, 0.5A max.)
6	GND	Ground
7	PADAT (+)	Serial data (0 to +5V)
8	PADAT (-)	Serial data inverted (0 to +5V)
9	GND	Ground
10 - 15	NC	Not connected

NOTE: (+) indicates standard TTL signal levels. (-) indicates standard TTL signal (logical complement). For differential operation, use both pins. TTL: $V_{OH} = +2.5V$, min; $V_{OL} = +0.5V$, max.

Table 2-5 AUDIO Connector (J6) Pin Descriptions.

Pin	Signal	Remarks
1	NORM BAL AUDIO	600 ohms balanced pair
2	NORM BAL RTN	
3	GND	
4	ALT BAL AUDIO	600 ohms balanced pair
5	ALT BAL RTN	
6	GND	
7	MIC/CW KEY	5V open ckt; 0.8 mA short circuit
8	GND	
9	NC	Not connected
10	TX KEY/	Output line - Open drain pull-down to ground (40V, 0.5A max.)
11	RF DISABLE/	LOW = RF off; TTL HIGH or open = RF on.
12-15	NC	Not connected



CHAPTER 3 OPERATING INSTRUCTIONS

Section I. LOCAL CONTROL

3-1 INTRODUCTION.

This chapter contains both local (manual) and remote control (using a remote control bus) operating instructions for the exciter including a description of the controls and displays and operating procedures.

3-2 LOCAL OPERATION.

Local (manual) operation is performed using the front panel controls and displays.

3-2.1 Controls and Display. (See figure 3-1.) Table 3-1 lists the front panel controls, and display, and their functions.

3-2.2 Parameter Entry. Figure 3-2 shows the parameter entry controls and display used to change the exciter parameters. Each is described below.

3-2.2.1 Vacuum Fluorescent Displays. The vacuum fluorescent display shows two basic displays; normal, and data entry. The displays are described below.

3-2.2.1.1 Normal Display. The normal display (figure 3-3) shows the basic exciter parameters including channel number, modulation type, audio source, carrier level, operating frequency, bandwidth selection, local or remote control selection, the soft key menus, and NEXT to indicate that there are other soft key labels available in the menu. Five soft keys (unlabeled) are located below the menu. (See figure 3-2) The labels for the soft keys appear in the menu display immediately above each key. When a soft key is pressed, the function above the key is selected. Pressing the NEXT key (when NEXT is displayed in the display) selects a different set of soft key labels.

NOTE

The **CarLev**: part of the display changes to reverse video when the TX_KEY and the PA_KEY signals are set, i.e., when the optional power amplifier is turned on. The display reverts back to normal when these signals are off.

3-2.2.1.2 Data Entry Display. The data entry display (figure 3-4) is present during most soft key entries. Basic exciter parameters are shown on the right side of the display. The center of the display is used for operator instructions and parameter entry display. (frequency entry is shown).

3-2.2.1.3 Meter Display. Although not considered a basic display, the meter display (figures 3-5 and 3-6) shows the RF and audio levels. It can usually be displayed from the normal or data entry display when the MTR/MNU key is pressed. The soft key menu is replaced with two or three meters depending on the modulation mode. In the ISB modulation mode, the AF2 meter shows the alternate audio input. Each of the meters has an analog arrow that shows the approximate reading on the meter while the center of the meter shows a numeric reading. Each meter is described below.

RF meter - Indicates RF output level from -33 to +27 dBm (output of less than -33 dBm displayed as "<-33").

AF meter - Indicates normal audio level at the rear panel 600 ohm input or front panel microphone input from -50 to +12 dBm.

AF2 meter - Indicates alternate audio level at the rear panel 600 ohm input from -50 to +12 dBm. (ISB modulation mode only).

NOTE

Either the normal display or the meter display may be displayed as the default. Pressing the MTR/MNU key will alternately select either display. Refer to paragraph 3-7.5.4 to change the default setting.

3-2.2.2 Controls. (See figure 3-2). Table 3-2 lists the parameter entry controls, the display and their functions.

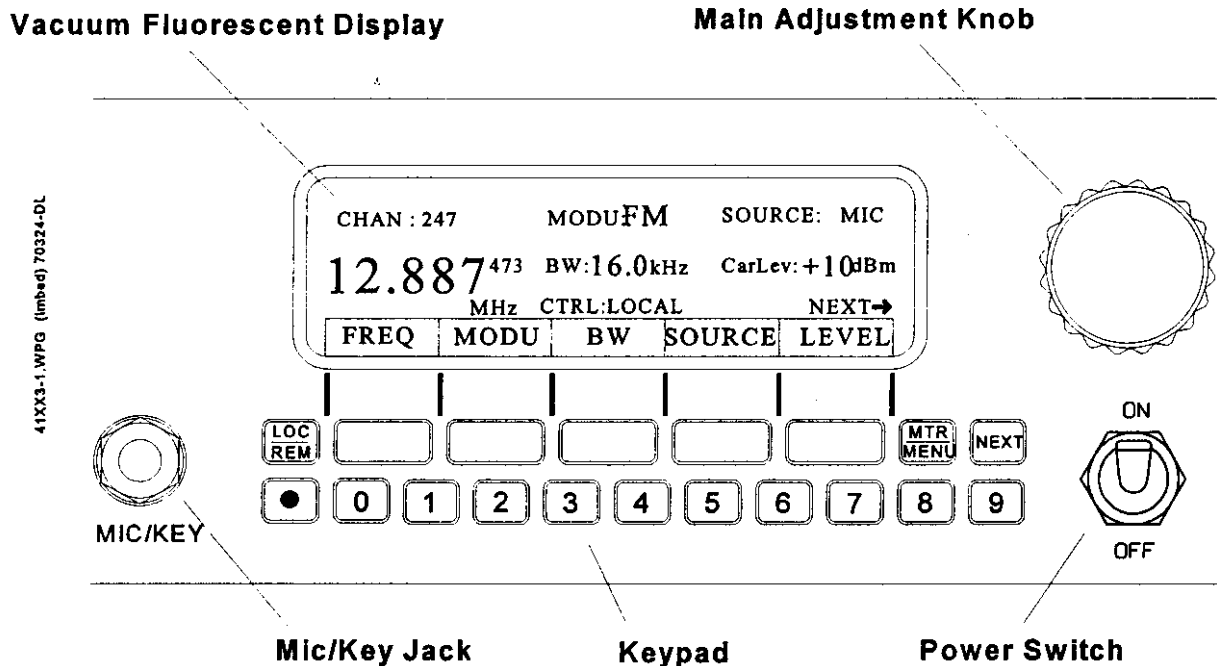

Figure 3-1 Front Panel Controls and Display.

Table 3-1 Front Panel Controls And Display.

Control	Function
Vacuum Fluorescent Display	Provides display of exciter parameters and other data to the operator.
Main Adjustment Knob	Provides adjustment of parameters using optical digital encoder on shaft of knob.
Power Switch	Exciter power on/off
Keypad	Provides data entry of exciter parameters.
MIC/KEY	Microphone/CW key input jack

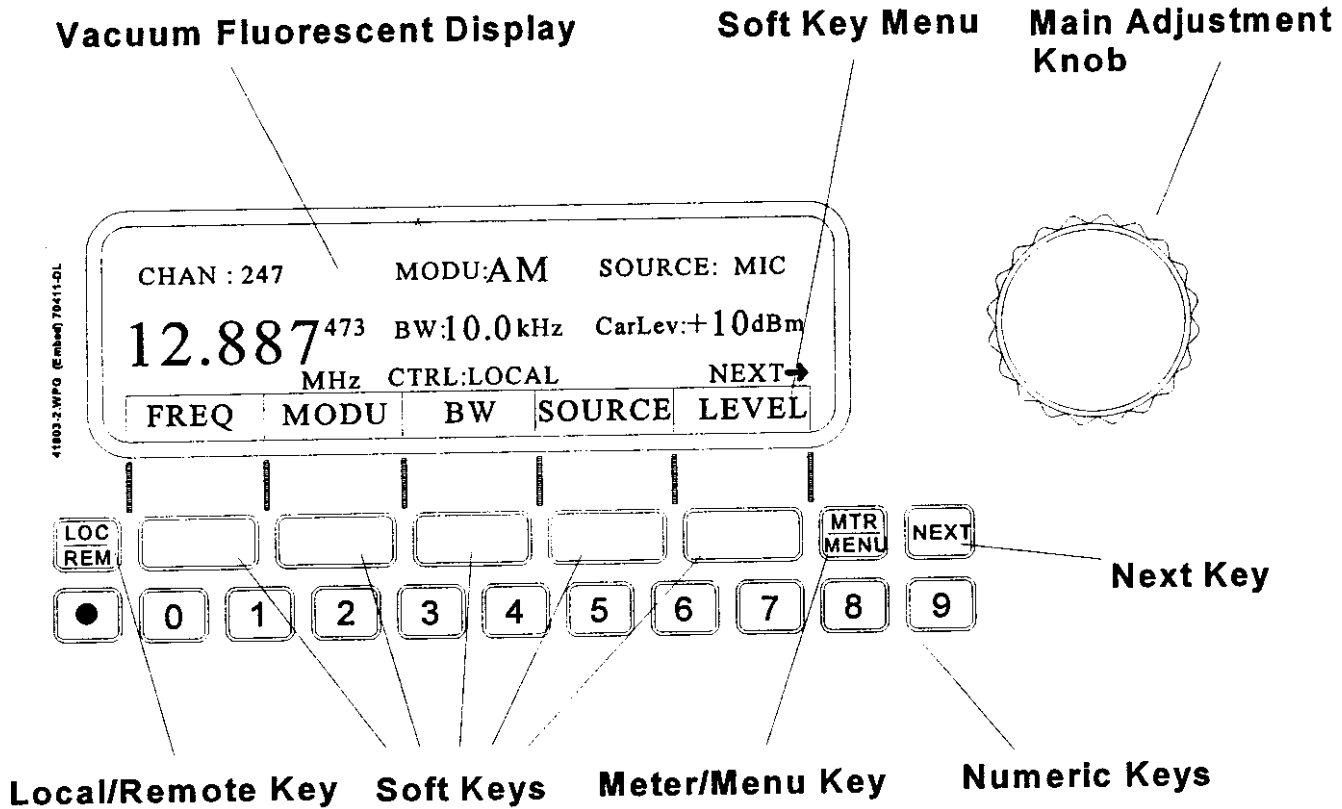

Figure 3-2 Parameter Entry Controls and Display.

Table 3-2 Parameter Entry Controls.

Control	Function
LOC/REM Key	Pressing the LOC/REM key selects either local (manual) or remote control of the exciter. When the desired control mode is selected CTRL:LOCAL or CTRL:REMOTE is displayed in the lower center of the vacuum fluorescent display.
Soft Keys	Five soft keys (unlabeled) are provided below the soft key menu. Each key corresponds to the menu selection immediately above the key. When a soft key is pressed, the function above the key is selected for parameter entry. Pressing the NEXT key allows a different set of soft keys to appear in the soft key menu.
MTR/MNU Key	The MTR/MNU key selects either the soft key menu display or the meter display.
Numeric Keys	The numeric keys are used to select numbers or decimal point for entry.
NEXT Key	The NEXT key allows selection of the next soft key menu.
Main Adjustment Knob	The main adjustment knob has a digital encoder on the knob's shaft that allows incrementing and decrementing numeric entries without using the numeric keys. Using the knob can save time in most cases by eliminating key presses.

41803-3.MPG (Imbed) 60103

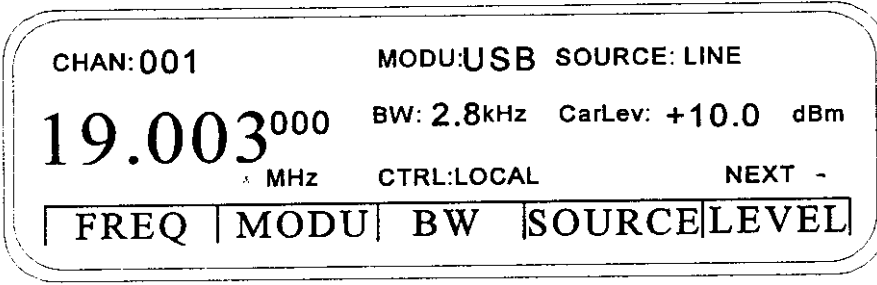

Figure 3-3 Normal Display.

41803-4.MPG (Imbed) 60103

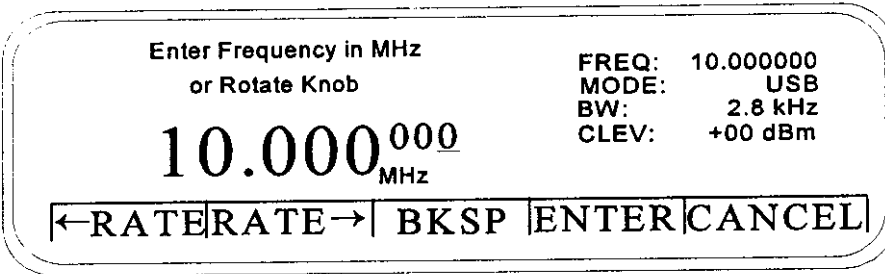

Figure 3-4 Data Entry Display.

41803-5.MPG (Imbed) 60103

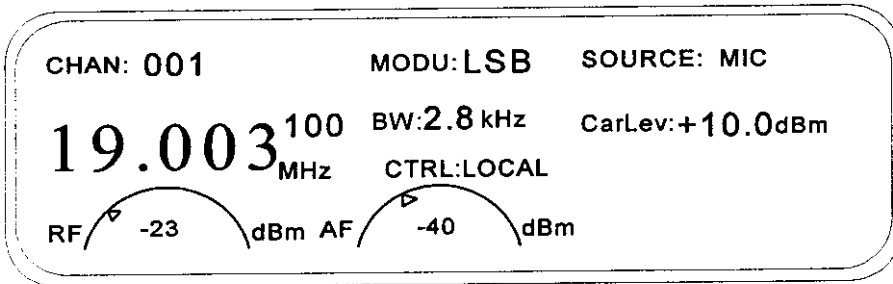

Figure 3-5 Meter Display.

41803-6.MPG (Imbed) 60103

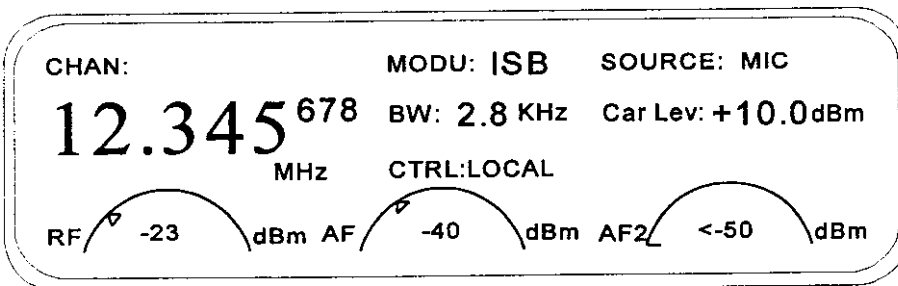

Figure 3-6 Meter/ISB Display.

3-3 POWER ON AND INITIAL SET UP.

To turn on and initially set up the exciter do the following:

1. Set the power switch ON.
2. Observe the display for initialization displays then the normal display.
3. To shut down the exciter, set the power switch to OFF.

NOTE

If the exciter is remotely controlled, the exciter must be initially configured for bus operation. The exciter's bus parameters must match the parameters of the remote controller. Perform the remote control configuration procedures in paragraph 3-7.5.2.2.

3-4 EMERGENCY OPERATION.

There are no emergency operating procedures.

3-5 INITIAL ADJUSTMENTS AND CONTROL SETTINGS.

There are no initial adjustments or control settings necessary.

3-6 NORMAL OPERATION.

Exciter functions are set or changed by watching the front panel display, while using the keypad (and/or main adjustment knob) to select and enter the parameters. If the meter display is shown (figure 3-5 or 3-6), press the MTR/MNU key to show the normal display containing the soft key menu (figure 3-3). Refer to paragraph 3-7 to set or change exciter parameters.

3-7 SETTING OR CHANGING EXCITER PARAMETERS.

When the exciter is first powered on, a power-on self test (POST) tests key circuits in the exciter, and performs a built-in test equipment (BITE) test. If a failure is detected, the display shows the failure code. When no failures are detected, the exciter displays the primary soft key menu. Each of the four main soft key menus are described in paragraph 3-7.1. The secondary and subsequent main soft key menus are selected by pressing the NEXT key. Pressing the MTR/MNU key while in most menus causes the exciter to switch to the METER display.

The following paragraphs lists the soft key menus used to change exciter parameters. Shaded keys indicate the next logical key to press in a particular sequence. If no shading is shown the operator has a choice of keys to press. Figure 3-7 shows a flow chart of all soft key menus.

NOTE

To cancel the current operation and return to the main menu, press the CANCEL soft key when displayed. To return to the function group menu press the RETURN soft key when displayed. This key allows the operator to continue entering other related functions without returning to the main menu. To return to the main menu press the DONE soft key when displayed.

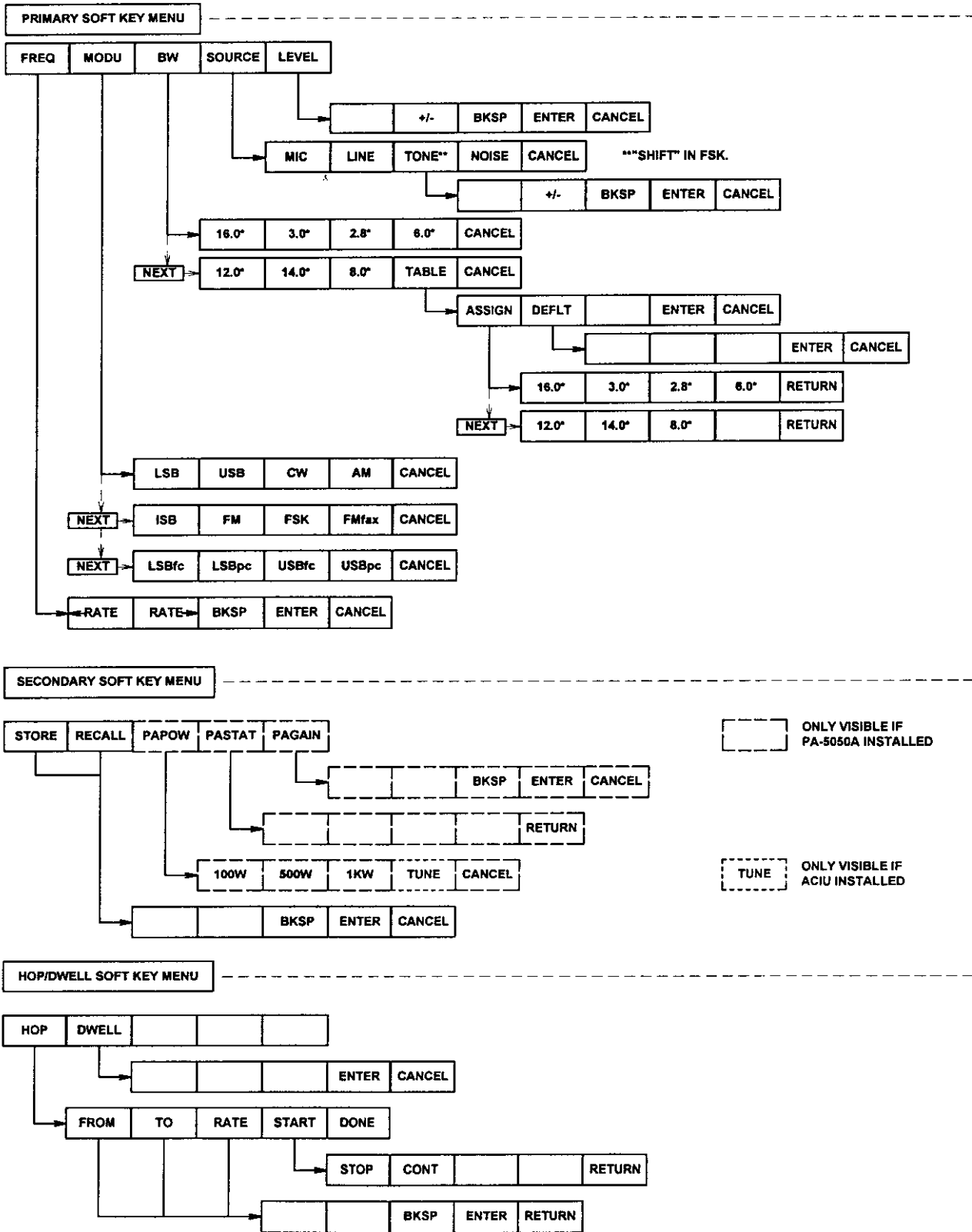

*OPERATOR ASSIGNABLE VALUE.
MAY BE DIFFERENT THAN SHOWN.

EMBED.FLO
70404 - DL

Figure 3-7 Soft Key Menus Overall Flow Diagram (Sheet 1 of 2).

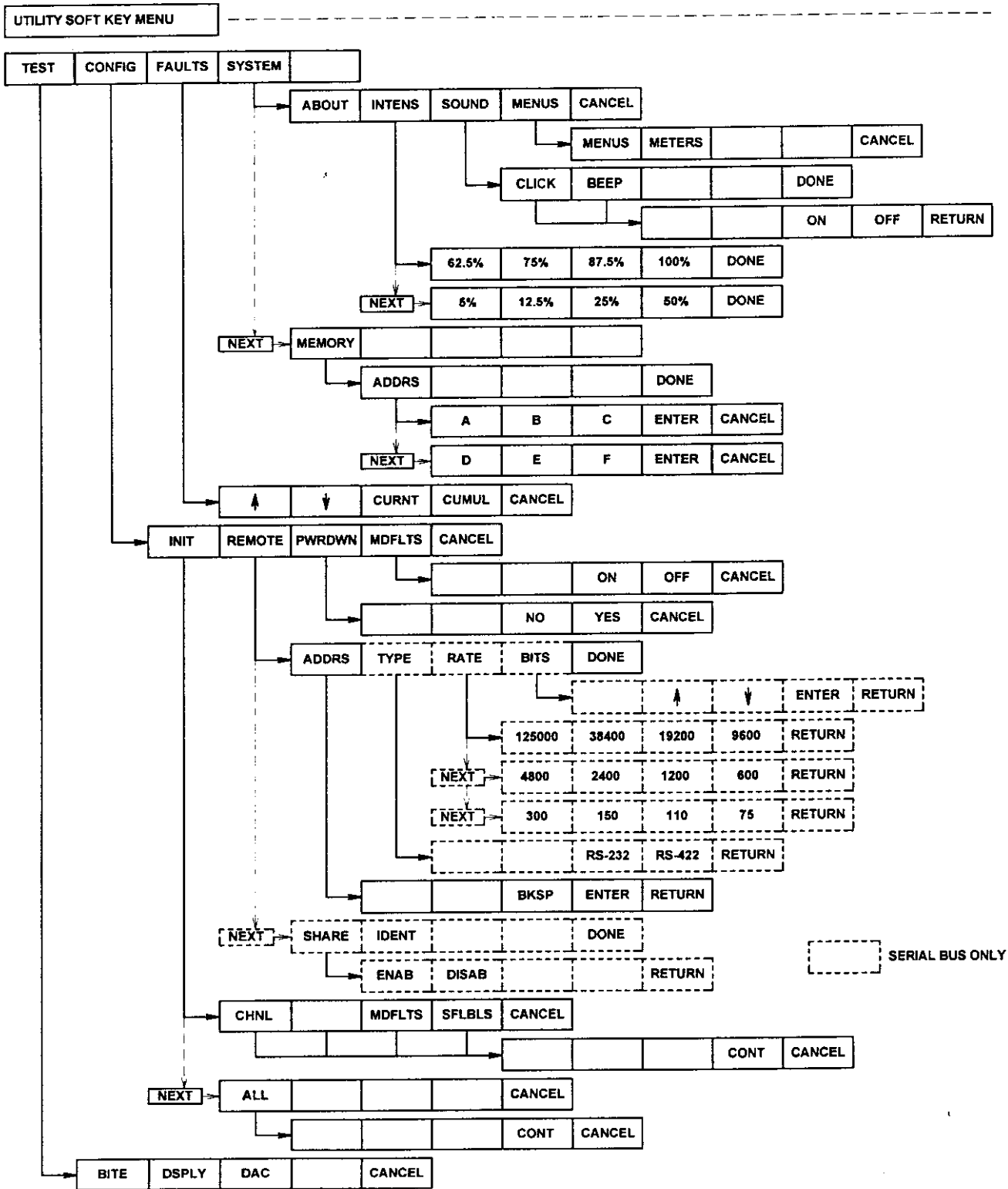

EMBED.FLO
60110-DL

Figure 3-7 Soft Key Menus Overall Flow Diagram (Sheet 2 of 2).

3-7.1 Basic Soft Key Menus. Four basic soft key menus can be displayed; primary, secondary, scan/sweep, and utility. Each menu is described below.

- A. Primary Soft Key Menu. This menu is displayed after power up and completion of POST testing.

Primary Soft Key Menu.

FREQ	MODU	BW	SOURCE	LEVEL		
					MTR MNU	NEXT

- B. Secondary Soft Key Menu. This menu is displayed by pressing the NEXT key while the primary soft key menu is shown. (Items shown in dashed lines only appear if optional PA-5050A is connected and on).

Secondary Soft Key Menu.

STORE	RECALL	PAPOW	PASTAT	PAGAIN		
					MTR MNU	NEXT

- C. Hop/Dwell Soft Key Menu. This menu is displayed by pressing the NEXT key while the secondary soft key menu is shown.

Hop/Dwell Soft Key Menu.

HOP	DWELL					
					MTR MNU	NEXT

- D. Utility Soft Key Menu. This menu is displayed by pressing the NEXT key while the scan/sweep soft key menu is shown.

Utility Soft Key Menu.

TEST	CONFIG	FAULTS	SYSTEM			
					MTR MNU	NEXT

Pressing NEXT while in this menu restores the primary soft key menu.

Each basic soft key menu is detailed in the following paragraphs.

3-7.2 Primary Soft Key Menu. The following paragraphs detail the primary soft key menu parameter entries.

3-7.2.1 Frequency. This function sets or changes the exciter frequency.

Primary Soft Key Menu.

FREQ	MODU	BW	SOURCE	LEVEL		
					MTR MNU	NEXT

Press the FREQ key to adjust the transmit frequency. The following menu appears.

FREQ Entry Soft Key Menu.

-RATE	RATE-	BKSP	ENTER	CANCEL		
					MTR MNU	NEXT

Change the transmit frequency with the keys or main adjustment knob. Repeatedly pressing the RATE keys moves a bar under the digits in the display. The bar under the digit indicates the tuning resolution of the main adjustment knob.

NOTE

The BKSP (backspace) key clears the previously entered digit and allows entry of correct digit.

3-7.2.2 Modu. This function selects the exciter modulation mode.

Primary Soft Key Menu.

FREQ	MODU	BW	SOURCE	LEVEL		
					MTR MNU	NEXT

Press the MODU key to change the modulation mode. The following menu appears. (Refer to table 3-3 for a description of each modulation mode).

MODU Soft Key Menu.

LSB	USB	CW	AM	CANCEL		
					MTR MNU	NEXT

Press the desired transmit modulation mode, or press the NEXT key and the following menu appears.

Table 3-3 Modulation Modes Descriptions.

Mode	Meaning	Description	Modulation Source	Keyline
LSB	Lower Sideband	Lower sideband only is transmitted	MIC, LINE (NORM), or TONE	Front MIC/KEY or rear MIC/CW KEY
USB	Upper Sideband	Upper sideband only is transmitted	MIC, LINE (NORM), or TONE	Front MIC/KEY or rear MIC/CW KEY
CW	Continuous Wave	Carrier frequency is transmitted only	None	Front MIC/KEY or rear MIC/CW KEY
AM	Amplitude Modulation	Carrier and both sidebands are transmitted	MIC, LINE (NORM), or TONE	Front MIC/KEY or rear MIC/CW KEY
ISB	Independent Sideband	Lower and upper sidebands only are transmitted (no carrier)	MIC, LINE (NORM), or TONE for USB LINE (ALT), or TONE for LSB (Tone transmitted simultaneously in both sidebands)	Front MIC/KEY or rear MIC/CW KEY
FM	Frequency Modulation	Transmit frequency varies with NORM channel audio input	MIC, LINE (NORM), or TONE	Front MIC/KEY or rear MIC/CW KEY
FSK	Frequency Shift Keyed	Transmit frequency is shifted above and below the center frequency by 1/2 the value selected by the SHIFT soft key. SHIFT can be changed "on-the-fly" during transmission. When a positive audio signal is sampled at the rear panel NORM BAL AUDIO input, the transmit frequency is shifted up. When a negative audio signal is sampled at the rear panel NORM BAL AUDIO input, the transmit frequency is shifted down.	Automatically switched to LINE (NORM)	Rear MIC/CW KEY
FMfax	Frequency Modulation Facsimile	Same as FM, except the signal is DC-coupled.	Automatically switched to LINE (NORM)	Rear MIC/CW KEY
LSBfc	Lower Sideband full carrier	Same as LSB with a carrier added at the center frequency equal to the power in the sideband (21 dBm max. in sideband)	MIC, LINE (NORM), or TONE	Front MIC/KEY or rear MIC/CW KEY
LSBpc	Lower Sideband partial carrier	Same as LSB with a carrier added at the center frequency equal in power to 12 dB less than the power in the sideband (25 dBm max. in sideband)	MIC, LINE (NORM), or TONE	Front MIC/KEY or rear MIC/CW KEY
USBfc	Upper Sideband full carrier	Same as USB with a carrier added at the center frequency equal to the power in the sideband (21 dBm max. in sideband)	MIC, LINE (NORM), or TONE	Front MIC/KEY or rear MIC/CW KEY
USBpc	Upper Sideband partial carrier	Same as USB with a carrier added at the center frequency equal in power to 12 dB less than the power in the sideband (25 dBm max. in sideband)	MIC, LINE (NORM), or TONE	Front MIC/KEY or rear MIC/CW KEY

MODU - NEXT Soft Key Menu.

ISB	FM	FSK	FMfax	CANCEL		
					MTR MNU	NEXT

Press the desired transmit modulation mode, or press the NEXT key to show the additional modulation modes.

MODU - NEXT NEXT Soft Key Menu.

LSBfc	LSBpc	USBfc	USBpc	CANCEL		
					MTR MNU	NEXT

Press the desired transmit modulation mode, or press the NEXT key to show the first modulation mode menu.

3-7.2.3 Bandwidth. This function sets or changes the exciter bandwidth.

NOTE

In ISB modulation mode the bandwidth is fixed at 2.8 kHz. In USB, or LSB only bandwidths between 100 Hz and 6.0 kHz can be selected. In AM or FM modulation modes all bandwidths between 100 kHz and 16.0 kHz may be selected. There are no CW bandwidth settings.

Primary Soft Key Menu.

FREQ	MODU	BW	SOURCE	LEVEL		
					MTR MNU	NEXT

Press BW to change the bandwidth. The following menu appears.

BW Soft Key Menu.

16.0*	3.0*	2.8*	6.0*	CANCEL		
					MTR MNU	NEXT

Press the desired bandwidth key or press the NEXT key to display additional bandwidths.

*Operator assignable value. May be different than shown.

BW - NEXT Soft Key Menu.

12.0*	14.0*	8.0*	TABLE	CANCEL		
					MTR MNU	NEXT

Press the desired bandwidth key or press the TABLE key for additional bandwidths.

BW - NEXT - TABLE Soft Key Menu.

ASSIGN	DEFLT		ENTER	CANCEL		
					MTR MNU	NEXT

When the TABLE key is pressed, the bandwidth is shown in the display. Rotate the main adjustment knob to select and change one of fifty-one bandwidths from 100 Hz to 16.0 kHz (or 6.0 kHz) depending on transmit modulation mode. After the desired bandwidth is displayed, press the ENTER key to enter the exciter bandwidth and exit the Bandwidth menu. If the CANCEL key is pressed instead of the ENTER key, the exciter reverts back to the original bandwidth.

3-7.2.3.1 Assigning Bandwidths to Soft Key Labels. The bandwidth soft key labels may be assigned different values from the bandwidth table using the ASSIGN function. To assign the bandwidths select the BW - NEXT - TABLE soft key menu as shown below. Rotate the main adjustment knob to select the desired bandwidth in the display.

BW - NEXT - TABLE Soft Key Menu.

ASSIGN	DEFLT		ENTER	CANCEL		
					MTR MNU	NEXT

Press the ASSIGN key to select the desired bandwidth from the table to the soft key menu. The following menu is displayed.

BW - NEXT - TABLE - ASSIGN Soft Key Menu.

16.0*	3.0*	2.8*	6.0*	RETURN		
					MTR MNU	NEXT

Press the desired soft key to reassign to a bandwidth, or press the NEXT key to display the additional bandwidth menu.

BW - NEXT - TABLE - ASSIGN - NEXT Soft Key Menu.

12.0*	14.0*	8.0*		RETURN		
					MTR MNU	NEXT

Press the desired soft key to assign to a bandwidth. The following menu is displayed.

BW - NEXT - TABLE Soft Key Menu.

ASSIGN	DEFLT		ENTER	CANCEL		
					MTR MNU	NEXT

Press the CANCEL key or assign additional bandwidths if desired.

3-7.2.3.2 Assigning Default Bandwidths To Transmit Modulation Modes. Bandwidths may be assigned to transmit modulation modes as default settings using the DEFLT function. To assign the bandwidths select the BW - NEXT - TABLE soft key menu as shown below. Rotate the main adjustment knob to select the desired bandwidth as shown in the display.

NOTE

The desired transmit modulation mode (to be assigned a bandwidth value) must be selected before selecting this function. USB and LSB share the same default bandwidth. Modulation mode default settings may be enabled or disabled through keypad configuration. Refer to section 3-7.5.2.3.

BW - NEXT - TABLE Soft Key Menu.

ASSIGN	DEFLT		ENTER	CANCEL		
					MTR MNU	NEXT

Press the DEFLT key and the following menu appears.

BW - NEXT - TABLE - DEFLT Soft Key Menu.

			ENTER	CANCEL		
					MTR MNU	NEXT

Press the ENTER key to assign the bandwidth to the selected transmit modulation mode.

3-7.2.4 Source. This function sets or changes the exciter audio source.

Primary Soft Key Menu.

FREQ	MODU	BW	SOURCE	LEVEL		
					MTR MNU	NEXT

Press the SOURCE key to select the SOURCE menu.

SOURCE Soft Key Menu.

MIC	LINE	-tone**	NOISE	CANCEL		
					MTR MNU	NEXT

Enter the audio source using the keypad.

- MIC = front panel microphone
- LINE = rear panel line input(s)
- tone = variable audio tone 50 - 6000 Hz (or SHIFT in FSK mode 50 - 6000 Hz).
- NOISE = white noise

If TONE (or SHIFT in FSK) is selected, the following menu appears:

LEVEL - Menu.

	+/-	BKSP	ENTER	CANCEL		
					MTR MNU	NEXT

Select the audio tone (or frequency shift in FSK) for the exciter by rotating the knob or entering the digits into the keypad. Press the backspace key to delete the last digit entered. Press ENTER key when done.

3-7.2.5 Level. This function sets or changes the exciter output power level.

NOTE

Level soft key selections are different depending on transmit modulation mode selected. Refer to the appropriate section below.

Primary Soft Key Menu.

FREQ	MODU	BW	SOURCE	LEVEL		
					MTR MNU	NEXT

Press the LEVEL key to select the exciter output power level (-33 to +27 dBm).

LEVEL - Menu.

	+/ -	BKSP	ENTER	CANCEL		
					MTR MNU	NEXT

Press the +/- key to toggle the polarity of the power level entry.

LEVEL - Menu.

	+/ -	BKSP	ENTER	CANCEL		
					MTR MNU	NEXT

Input the power level into the exciter by rotating the knob or entering the digits into the keypad. Press the backspace key to delete the last digit entered.

LEVEL - Menu.

	+/ -	BKSP	ENTER	CANCEL		
					MTR MNU	NEXT

Press the LEVEL key to assign the output power level to the exciter.

3-7.3 *Secondary Soft Key Menu.* The following paragraphs detail parameter entry from the secondary soft key menu. To display the secondary soft key menu, press the NEXT key from the primary soft key menu.

3-7.3.1 *Store.* This function stores all current exciter parameters in a selected memory channel. All exciter parameters are first entered using the keypad and/or main adjustment knob. The memory channel is then selected and all data is copied to the memory channel.

The following parameter settings may be stored in each memory channel: frequency, power level, exciter modulation mode, audio source, bandwidth, hop rate, and dwell time.

Secondary Soft Key Menu.

STORE	RECALL	PAPOW	PASTAT	PAGAIN		
					MTR MNU	NEXT

Press the STORE key to store current parameters in a memory channel. The following menu appears.

STORE Soft Key Menu.

		BKSP	ENTER	CANCEL		
					MTR MNU	NEXT

Select a memory channel to store current parameters using the numeric keys or main adjustment knob. Press the ENTER key when the desired channel is displayed. Range = 000 to 249.

NOTE

The BKSP key erases the previously entered digit if the keypad is used for numeric entry.

3-7.3.2 Recall. This function recalls all exciter parameters for a selected memory channel as current exciter parameters.

Secondary Soft Key Menu.

STORE	RECALL	PAPOW	PASTAT	PAGAIN		
					MTR MNU	NEXT

Press the RECALL key to recall memory channel parameters. The following menu appears.

RECALL Soft Key Menu.

		BKSP	ENTER	CANCEL		
					MTR MNU	NEXT

Select a memory channel for display using the numeric keys or main adjustment knob. When the desired channel is displayed, press ENTER to select that channel and return to normal operation. Range = 000 to 249.

3-7.3.3 PAPOW. This function allows RF power selection for the optional PA-5050A power amplifier. If the PA-5050A power amplifier is not installed, this function will not be displayed.

Secondary Soft Key Menu.

STORE	RECALL	PAPOW	PASTAT	PAGAIN		
					MTR MNU	NEXT

Press the PAPOW key to show the power selections. The following menu appears.

PAPOW Soft Key Menu.

1KW	500W	100W	TUNE	CANCEL		
					MTR MNU	NEXT

CAUTION

When any of the above soft keys are pressed (except CANCEL), the exciter and PA-5050A are automatically keyed. The attenuator in the PA-5050A is automatically adjusted to produce the selected RF power level output.

Press the desired soft key to select the RF power level for the PA-5050A power amplifier. If the optional ACIU is installed, pressing the TUNE soft key directs the Antenna Coupler to tune with 100 watts of power from the PA-5050A. The TUNE soft key only appears if the ACIU is installed.

3-7.3.4 PASTAT. This function causes the current status of the PA-5050A power amplifier to be displayed.

Secondary Soft Key Menu.

STORE	RECALL	PAPOW	PASTAT	PAGAIN		
					MTR MNU	NEXT

Press the PASTAT key to show the current PA-5050A power amplifier status. The following menu appears.

PASTAT Soft Key Menu.

				RETURN		
					MTR MNU	NEXT

View the current PA-5050A status information, and then press RETURN to return to the normal display.

3-7.3.5 PAGAIN. This function allows the operator to adjust the gain of the PA-5050A power amplifier (if installed).

Secondary Soft Key Menu.

STORE	RECALL	PAPOW	PASTAT	PAGAIN		
					MTR MNU	NEXT

Press the PAGAIN key to input the gain of the PA-5050A power amplifier. The following menu appears.

PAGAIN Soft Key Menu.

		BKSPC	ENTER	CANCEL		
					MTR MNU	NEXT

Select the PA gain attenuation in dB of the PA-5050A power amplifier by rotating the main adjustment knob or entering the digits into the keypad. Press the backspace key to delete the last digit entered. Press ENTER key when desired attenuation is displayed. (Range = -32.00 to 00.00 dB).

3-7.4 Hop/Dwell Soft Key Menu.

The following paragraphs detail parameter entry from the hop/dwell soft key menu. To display the hop/dwell soft key menu, press the NEXT key from the secondary soft key menu.

3-7.4.1 Hop.

NOTE

Before performing a frequency hop function, frequencies and other parameters should be determined and set into designated memory channels.

Hop is the sequential continuous recall of a sequence of memory channels. The CPU in the exciter uses the data stored in each channel to select frequency, modulation mode, bandwidth, power level, dwell time, and all other stored parameters to operate the exciter. The exciter will stop on a frequency for the current dwell time and then tune to the next transmit frequency that is stored in memory. The recall begins at the memory channel most recently recalled.

CAUTION

Since the exciter is keyed every time the channel is changed during this operation, the HOP function should only be used with external equipment designed for this function. If frequency separation between channels is too great, damage to the external power amplifier and/or antenna system may occur due to high and rapid VSWR fluctuations.

Hop/Dwell Soft Key Menu.

HOP	DWELL					
					MTR MNU	NEXT

Press the HOP key and the following menu appears.

Hop/Dwell - HOP Soft Key Menu.

FROM	TO	RATE	START	DONE		
					MTR MNU	NEXT

Press the FROM key and the following menu appears.

Hop/Dwell - HOP - FROM Soft Key Menu.

		BKSP	ENTER	RETURN		
					MTR MNU	NEXT

Select the desired starting channel using the keypad or main adjustment knob, and press ENTER. The menu will switch back to the Hop/Dwell - HOP menu as shown below.

Hop/Dwell - HOP Soft Key Menu.

FROM	TO	RATE	START	DONE		
					MTR MNU	NEXT

Press the TO key and the following menu appears.

Hop/Dwell - HOP - Soft Key Menu.

		BKSP	ENTER	RETURN		
					MTR MNU	NEXT

Select the desired ending channel using the keypad or main adjustment knob, and press ENTER. The menu will switch back to the Hop/Dwell - HOP menu as shown below.

Hop/Dwell - HOP Soft Key Menu.

FROM	TO	RATE	START	RETURN		
					MTR MNU	NEXT

Press RATE (if desired) to set the rate the exciter changes channels during hopping operation. The following menu appears if RATE is selected.

Hop/Dwell - HOP - RATE Soft Key Menu.

		BKSP	ENTER	RETURN		
					MTR MNU	NEXT

Select the desired hop rate and press ENTER. The menu will switch back to the Hop/Dwell - HOP menu as shown below.

Hop/Dwell - HOP Soft Key Menu.

FROM	TO	RATE	START	DONE		
					MTR MNU	NEXT

Press the START key to start the channel recall (frequency hopping). The exciter will change ("hop") channels between the FROM and TO channels selected. The following menu appears.

Hop/Dwell - HOP Soft Key Menu.

STOP	CONT			RETURN		
					MTR MNU	NEXT

Press STOP to stop the frequency hopping, or CONT to continue the frequency hopping after stopping.

3-7.4.2 Dwell. The dwell time setting is the time duration (in seconds) the exciter remains on a channel during frequency hopping. If the dwell time is set to zero, the exciter will move immediately to the next channel after a frequency is transmitted.

Hop/Dwell Soft Key Menu.

HOP	DWELL					
					MTR MNU	NEXT

Press the DWELL key to select the dwell time for frequency hopping. The following menu appears.

DWELL Soft Key Menu.

			ENTER	CANCEL		
					MTR MNU	NEXT

Select the desired dwell time for the frequency hop function. Enter 0 for no dwell. Press ENTER when done. Range = 0 - 9 seconds.

3-7.5 Utility Soft Key Menu. The following paragraphs detail parameter entry from the utility soft key menu. To display the utility soft key menu, press the NEXT key from the Hop/Dwell soft key menu.

3-7.5.1 Test. This function allows selection of exciter tests.

Utility Soft Key Menu.

TEST	CONFIG	FAULTS	SYSTEM			
					MTR MNU	NEXT

Press the TEST key to perform exciter tests. The following menu appears.

Utility - TEST Soft Key Menu.

BITE	DSPLY	DAC		CANCEL		
					MTR MNU	NEXT

Press the BITE soft key to select the built-in test equipment test. Observe the display for fault information.

Utility - TEST Soft Key Menu.

BITE	DSPLY	DAC		CANCEL		
					MTR MNU	NEXT

Press the DSPLY soft key to select the front panel display test. After the test is complete, press any soft key when prompted. The normal display will be shown with the primary soft key menu.

Utility - TEST Soft Key Menu.

BITE	DSPLY	DAC		CANCEL		
					MTR MNU	NEXT

NOTE

When this test is activated, the exciter stops transmitting signals, and a fault indication may appear. This is normal.

Press the DAC soft key to select test outputs from the digital-to-analog converter in the digital module. The display will show what certain test point indications should be.

3-7.5.2 Configuration. This function configures the exciter by initializing (clearing) non-volatile memory, setting the remote control parameters, and setting the default settings.

Utility Soft Key Menu.

TEST	CONFIG	FAULTS	SYSTEM			
					MTR MNU	NEXT

Press the CONFIG key to select the exciter configuration. The following menu appears.

3-7.5.2.1 Clearing Non-Volatile Memory. To initialize (clear) non-volatile memory select the Utility - CONFIG soft key menu as shown below.

Utility - CONFIG Soft Key Menu.

INIT	REMOTE	PWRDWN	ROLOFF	CANCEL		
					MTR MNU	NEXT

Press INIT to initialize (clear) the non-volatile memory. The following menu appears.

Utility - CONFIG - INIT Soft Key Menu.

CHNL		MDFLTS	SFLBLS	CANCEL		
					MTR MNU	NEXT

Press CHNL to initialize (clear) the memory channels and change them to factory default settings. The following menu appears.

Utility - CONFIG - INIT - CHNL Soft Key Menu.

			CONT	CANCEL		
					MTR MNU	NEXT

Press CONT to continue or CANCEL to cancel the function.

NOTE

To confirm the factory default settings after initialization, ensure the Mode Default function is off. The memory channel factory default settings are:

- Frequency: 10.0 MHz Power Level: 0 dBm
- Modulation mode: AM Source: Mic
- Bandwidth: 6 kHz Hop Rate: 100 channels/sec.
- Dwell time: 3 Seconds

Utility - CONFIG - INIT Soft Key Menu.

CHNL		MDFLTS	SFLBLS	CANCEL		
					MTR MNU	NEXT

Press MDFLTS to reset the default BW setting to the initial value. The following menu appears.

Utility - CONFIG - INIT - MDFLTS Soft Key Menu.

			CONT	CANCEL		
					MTR MNU	NEXT

Press CONT to continue or CANCEL to cancel the function.

Utility - CONFIG - INIT Soft Key Menu.

CHNL		MDFLTS	SFLBLS	CANCEL		
					MTR MNU	NEXT

Press SFLBLS to reset the BW soft key labels to the initial values. The following menu appears.

Utility - CONFIG - INIT - SFLBLS Soft Key Menu.

			CONT	CANCEL		
					MTR MNU	NEXT

Press CONT to continue or CANCEL to cancel the function.

To initialize all of the functions press the NEXT key from the Utility - CONFIG menu.

NOTE

When the following function is performed, all non-volatile memory data will be lost.

Utility - CONFIG - INIT Soft Key Menu.

CHNL		MDFLTS	SFLBLS	CANCEL		
					MTR MNU	NEXT

Press the NEXT key and the following menu appears.

Utility - CONFIG - INIT - NEXT Soft Key Menu.

ALL				CANCEL		
					MTR MNU	NEXT

Press the ALL key to reset all non-volatile memory values to default settings.

Utility - CONFIG - INIT - NEXT - ALL Soft Key Menu.

			CONT	CANCEL		
					MTR MNU	NEXT

Press CONT to continue or CANCEL to cancel the function.

3-7.5.2.2 Configuring Exciter Remote Control Operation. Two basic remote control buses are optionally available; serial or IEEE-488. Refer to the correct sub-paragraph below for the installed configuration.

3-7.5.2.2.1 Serial Bus. (If so equipped). To configure the exciter serial bus remote control operation, select the Utility - CONFIG soft key menu as shown below.

Utility - CONFIG Soft Key Menu.

INIT	REMOTE	PWRDWN	ROLOFF	CANCEL		
					MTR MNU	NEXT

Press REMOTE to change the remote control bus configuration. The following menu appears.

Utility - CONFIG - REMOTE Soft Key Menu.

ADDRS	TYPE	RATE	BITS	DONE		
					MTR MNU	NEXT

Press ADDRS to select the exciter's bus address. The following menu appears.

Utility - CONFIG - REMOTE Soft Key Menu.

		BKSP	ENTER	RETURN		
					MTR MNU	NEXT

Enter the exciter's bus address using the keypad or knob (range = 000 - 254). Press ENTER when done.

NOTE

Pressing the RETURN key switches to the Utility - CONFIG - REMOTE soft key menu without changing the original address.

Utility - CONFIG - REMOTE Soft Key Menu.

ADDRS	TYPE	RATE	BITS	DONE		
					MTR MNU	NEXT

Press the TYPE key to select the remote control bus type. The following menu appears.

Utility - CONFIG - REMOTE - TYPE Soft Key Menu.

		RS-232	RS-422	RETURN		
					MTR MNU	NEXT

Press the desired remote control bus type key.

Utility - CONFIG - REMOTE Soft Key Menu.

ADDRS	TYPE	RATE	BITS	DONE		
					MTR MNU	NEXT

Press the RATE key to change the serial bus rate. The following menu appears.

Utility - CONFIG - REMOTE - RATE Soft Key Menu.

125000	38400	19200	9600	RETURN		
					MTR MNU	NEXT

Select the desired serial bus baud rate, or press the NEXT key and the following menu appears.

Utility - CONFIG - REMOTE - RATE - NEXT Soft Key Menu.

4800	2400	1200	600	RETURN		
					MTR MNU	NEXT

Select the desired serial bus baud rate or press the NEXT key again.

Utility - CONFIG - REMOTE - RATE - NEXT - NEXT Soft Key Menu.

300	150	110	75	RETURN		
					MTR MNU	NEXT

Select the desired serial bus baud rate, or press the NEXT key to return to the first RATE menu.

Utility - CONFIG - REMOTE Soft Key Menu.

ADDRS	TYPE	RATE	BITS	DONE		
					MTR MNU	NEXT

Press the BITS key to configure the serial bus line parameters. The following menu appears.

Utility - CONFIG - REMOTE - BITS Soft Key Menu.

	↑	↓	ENTER	RETURN		
					MTR MNU	NEXT

Press the up or down arrows to select new line parameters as shown on the display and listed in the following table. Press the ENTER key when the desired parameters are displayed.

DATA BITS	STOP BIT	PARITY
8	2	ODD
8	1	ODD
7	2	ODD
7	1	ODD
8	2	EVEN
8	1	EVEN
7	2	EVEN
7	1	EVEN
8	2	NO
8	1	NO
7	2	NO
7	1	NO

Utility - CONFIG - REMOTE Soft Key Menu.

ADDRS	TYPE	RATE	BITS	DONE		
					MTR MNU	NEXT

Press the DONE key to return to the primary soft key menu, press the NEXT key and the following menu appears.

Utility - CONFIG - REMOTE - NEXT Soft Key Menu.

SHARE	IDENT			DONE		
					MTR MNU	NEXT

Press the SHARE key to select party line or single bus. The following menu appears.

Utility - CONFIG - REMOTE - NEXT - SHARE Soft Key Menu.

ENAB	DISAB			RETURN		
					MTR MNU	NEXT

Press ENAB to enable bus sharing for party line bus, or select DISAB for single exciter on bus.

Utility - CONFIG - REMOTE - NEXT Soft Key Menu.

SHARE	IDENT			DONE		
					MTR MNU	NEXT

Press the IDENT key to send the identification message out over the bus. The message identifies the manufacturer, the equipment name, the firmware version number, and date, and copyright notice. This message is less than 125 characters long.

3-7.5.2.2.2 IEEE-488 Bus. (If so equipped). To configure the exciter IEEE-488 bus remote control operation, select the Utility - CONFIG soft key menu as shown below.

Utility - CONFIG Soft Key Menu.

INIT	REMOTE	PWRDWN	ROLOFF	CANCEL		
					MTR MNU	NEXT

Press REMOTE to change the remote control bus configuration. The following menu appears.

Utility - CONFIG - REMOTE Soft Key Menu.

ADDRS	TYPE	RATE	BITS	DONE		
					MTR MNU	NEXT

Press ADDRS to select the exciter's bus address. The following menu appears.

Utility - CONFIG - REMOTE Soft Key Menu.

		BKSP	ENTER	RETURN		
					MTR MNU	NEXT

Enter the exciter's bus address using the keypad or knob (range = 000 - 030). Press ENTER when done.

3-7.5.2.3 Configuring Exciter Default Settings. To configure the exciter's default settings select Utility - CONFIG soft key menu as shown below.

Utility - CONFIG Soft Key Menu.

INIT	REMOTE	PWRDWN	MDFLTS	CANCEL		
					MTR MNU	NEXT

Select PWRDWN to determine if the current exciter operating parameters will be saved or not when the exciter is turned off. The following menu appears.

Utility - CONFIG - MEMORY Soft Key Menu.

		NO	YES	CANCEL		
					MTR MNU	NEXT

Press NO or YES as desired, and the display goes back to the primary menu.

Utility - CONFIG Soft Key Menu.

INIT	REMOTE	PWRDWN	MDFLTS	CANCEL		
					MTR MNU	NEXT

Press the MDFLTS key to turn the BW modulation mode defaults on or off. The following menu appears.

Utility - CONFIG - NEXT MDFLTS Soft Key Menu.

		ON	OFF	CANCEL		
					MTR MNU	NEXT

Press the ON or OFF key to select whether BW reverts to default values when the transmit modulation mode is changed.

3-7.5.3 Faults. This function allows review of current or cumulative faults.

Utility Soft Key Menu.

TEST	CONFIG	FAULTS	SYSTEM			
					MTR MNU	NEXT

Press FAULTS key to show the current or cumulative faults in the exciter. The following menu appears.

Utility - FAULTS Soft Key Menu.

↑	↓	CURNT	CUMUL	CANCEL		
					MTR MNU	NEXT

The initial display shows the current fault status. Press CUMUL to switch to display of cumulative faults since power was turned on. Press CURNT to switch back to display of current faults. When pressed, the ↑ ↓ keys allow scrolling through multiple faults. Up to 16 current (CURNT) or cumulative (CUMUL) faults may be displayed. If the fault light is lit on the vacuum fluorescent display, press the CURNT key to display the fault list. The faults do not appear in any significant order on the list. To display the cumulative faults that have occurred since the exciter was turned on, press the CUMUL key. Identical recurring faults will only appear once on the list. Refer to paragraph 5-5.2.3 for details.

3-7.5.4 System. This function allows selection of system related items including: software version identification, display intensity, sound, and menu display default.

Utility Soft Key Menu.

TEST	CONFIG	FAULTS	SYSTEM			
					MTR MNU	NEXT

Press SYSTEM to select system related items. The following soft key menu appears.

Utility - SYSTEM Soft Key Menu.

ABOUT	INTENS	SOUND	MENUS	CANCEL		
					MTR MNU	NEXT

Press the ABOUT key to display the exciter identification and software version number. Press the NEXT key to show the DSP firmware version number. Press any soft key to return to the normal display.

Utility - SYSTEM Soft Key Menu.

ABOUT	INTENS	SOUND	MENUS	CANCEL		
					MTR MNU	NEXT

Press the INTENS key to change the intensity of the front panel display. The following soft key menu appears.

Utility - INTENS Soft Key Menu.

62.5%	75%	87.5%	100%	DONE		
					MTR MNU	NEXT

Select the desired display intensity, and press DONE; or press the NEXT key and the following menu appears.

NOTE

Display may not be visible in bright ambient light if 5% intensity is selected.

Utility - INTENS - NEXT Soft Key Menu.

5%	12.5%	25%	50%	DONE		
					MTR MNU	NEXT

Select the desired display intensity, and press DONE; or press the NEXT key to return to the previous menu.

Utility - SYSTEM Soft Key Menu.

ABOUT	INTENS	SOUND	MENUS	CANCEL		
					MTR MNU	NEXT

Press the SOUND key to select the sound options. The following menu appears.

Utility - SYSTEM - SOUND Soft Key Menu.

CLICK	BEEP			DONE		
					MTR MNU	NEXT

Press CLICK to enable key clicks on or off when keys are pressed. The following menus appears.

Utility - SYSTEM - SOUND - CLICK Soft Key Menu.

		ON	OFF	RETURN		
					MTR MNU	NEXT

Select ON or OFF. Press RETURN to return to the previous menu.

Utility - SYSTEM - SOUND Soft Key Menu.

CLICK	BEEP			DONE		
					MTR MNU	NEXT

Press BEEP to enable warning beeps. The following menu appears.

Utility - SYSTEM - SOUND - BEEP Soft Key Menu.

		ON	OFF	RETURN		
					MTR MNU	NEXT

Select ON or OFF. Press RETURN to return to the previous menu.

Utility - SYSTEM Soft Key Menu.

ABOUT	INTENS	SOUND	MENUS	CANCEL		
					MTR MNU	NEXT

Press MENUS to display the soft key menus or the meters as the default. The following menu appears.

Utility - SYSTEM - MENUS Soft Key Menu.

MENUS	METERS			CANCEL		
					MTR MNU	NEXT

Press the MENUS key to set the normal display to show the soft key menus as the default. Press the METERS key to set the normal display to show the meters as the default.

Utility - SYSTEM Soft Key Menu.

ABOUT	INTENS	SOUND	MENUS	CANCEL		
					MTR MNU	NEXT

Press the NEXT key and the following menu appears.

Utility - SYSTEM - NEXT Soft Key Menu.

MEMORY						
					MTR MNU	NEXT

Press the MEMORY key to observe the HEX/ASCII display of memory (factory use only). The following menu appears.

Utility - SYSTEM - NEXT - MEMORY Soft Key Menu.

ADDRS				DONE		
					MTR MNU	NEXT

Use the main adjustment knob to scroll through the memory locations, or press the ADDRS key and the following menu appears.

Utility - SYSTEM - NEXT - MEMORY - ADDRS Soft Key Menu.

A	B	C	ENTER	CANCEL		
					MTR MNU	NEXT

Use the numeric keypad and the letter soft keys above to select specific hexadecimal memory locations for display. To enter hexadecimal letters D, E, and F, press the NEXT key and the following menu appears.

Utility - SYSTEM - NEXT - MEMORY - ADDRS - NEXT Soft Key Menu.

D	E	F	ENTER	CANCEL		
					MTR MNU	NEXT

Select the desired address location and press ENT.

Section II. REMOTE CONTROL

Two different interface standards are available for the T-4150/80 exciter: Serial and IEEE-488. The serial interface includes both unbalanced (RS-232) and balanced (RS-422) line interfaces. To configure the exciter's hardware for Serial or IEEE-488 operation, it is only necessary to change a small plug-in daughter board in the Digital Module, and the rear panel mounted bus plate with its associated cable. The control firmware detects the interface type at power up and then operates it. Refer to Chapter 2 for installation and electrical characteristics.

Parameters associated with the remote control interface can be checked and changed from the front panel of the exciter. For the IEEE-488 interface the only parameter that may be set is the exciter's talk and listen address. For the serial interface, the bus address, bus type (RS-232 or RS-422), baud rate, bus sharing option, and line parameters may be set. (Line parameters include number of data bits, number of stop bits and parity options).

Each type of interface is described below.

3-8 REMOTE OPERATION USING SERIAL BUS.

The exciter may be optionally operated under remote control using a serial bus and a suitable controller. To operate in this manner, press the LOC/REM key until CTRL:REMOTE appears on the display. The LOC/REM key has positive control over the remote control function. However, the bus controller may allow control or prevent local control when the exciter is in the REMOTE mode.

Ensure that the communications parameters are set in accordance with the system requirements. Refer to Chapter 2 for the correct installation procedures. The bus address, bus type (RS-232 or RS-422), baud rate, number of data bits, type of parity used, and number of stop bits must match the requirements of the system controller. Refer to paragraph 3-7.5.2.2.1 to configure the remote control line parameters for the serial bus.

3-8.1 Serial Bus Description. The serial interface includes both unbalanced (RS-232) and balanced (RS-422) line interfaces. The control firmware is designed to detect the interface type (serial, IEEE-488, or none) at power up. However, it does not detect the type of serial bus. This must be selected by the operator (refer to paragraph 3-7.5.2.2.1).

3-8.2 Serial Bus Message Format. All transmissions, in either direction, conform to the message format shown in figure 3-8. All transmitted and received characters will be encoded and interpreted as conforming to the ASCII character code.

Each character in the message is passed in an asynchronous serial format as shown in figure 3-9. The number of data bits, number of stop bits, parity options and baud rate are all selectable from the front panel of the exciter through the keypad. These selections are stored in non-volatile memory. All characters are in ASCII code.

3-8.3 Serial Bus Message Types. All messages are divided into two major categories: command messages and status messages. Each category is discussed in the following paragraphs:

3-8.3.1 Serial Bus Command Messages. Command messages are sent from the controller to the exciter and are subdivided into two classes as follows:

3-8.3.1.1 Serial Bus Exciter Command Messages. Exciter command messages contain commands that are passed to the exciter. They may command the exciter to change operational parameters or to report back operational status.

3-8.3.1.2 Serial Bus Interface Command Messages. Interface command messages contain commands that are acted upon by the communications interface in the exciter. These commands cause the interface to change modes or report status.

3-8.3.2 Serial Bus Status Messages. Status messages are sent from the exciter to the controller and are subdivided into two classes as follows:

3-8.3.2.1 Serial Bus Exciter Status Messages. Exciter status messages contain information about the operational status of the exciter. These messages are sent as a reply to exciter command messages that request a status report.

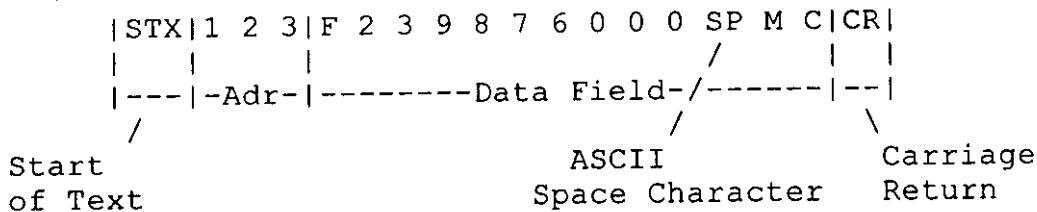

NOTES:

The first character of a transmission will always be STX (start of text, ASCII code 02).

The second, third, and fourth characters will contain the address in decimal, with the most significant digit first, of the exciter sending the transmission or to which it is being sent by the controller. The address code for any exciter may be any number from 000 to 254 provided that it is not used by any other unit connected to the bus. Address 255 is reserved for "broadcasting" to all exciters on the bus (refer to para 3-8.6). The controller has no address. All three digits must be transmitted. Addresses less than 100 must be filled with '0' digits on the left. The address is set from the front panel with the soft key sequence CONFIG- REMOTE- ADDRS.

The fifth character of the transmission is the beginning of the data field. This field may contain as few as one or as many as 250 characters. The data field may contain one or more messages. If more than one message is contained in the data field, each message must be separated from the next by one or more blank (space) characters.

Any number of messages may be included in the data field provided that the maximum number of characters is not exceeded. There are, however, certain request for status commands that may not be mixed with any other request for status commands in the same transmission. These messages will be noted as such in table 3-6.

The final character of the transmission will be a CR (carriage return). This character will follow the last character of the data field.

This transmission above from the controller is addressed to the exciter with address 123 and contains two messages: "F23987600" and "MC".

When sending messages to the exciter that require numeric values as arguments, it is not necessary to include leading zeros. For example, to send a message to change the frequency to 5.67 MHz, the command message "F5670000" may be given in place of "F05670000". When a request for a status message is made, the reply will always include any leading zeros so that the value may be extracted by counting characters in the message.

Figure 3-8 Serial Bus Message Format.

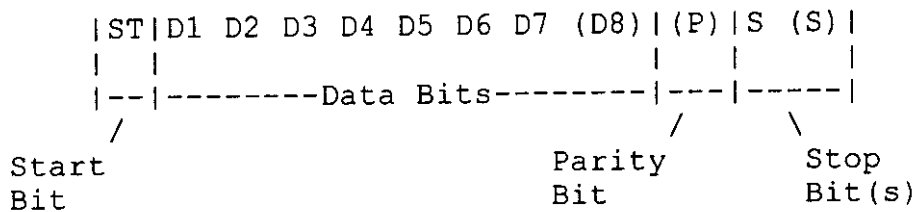

NOTES:

Information is passed in full duplex as characters in an asynchronous serial format. Each character consists of a start bit, 7 or 8 data bits with the least significant bit sent first, an optional parity bit which may provide odd or even parity, and one or two stop bits. The serial transmission rate may be set to each of the following standard rates: 75, 110, 150, 300, 600, 1200, 2400, 4800, 9600, 19200, 38400, and 125000 bits per second. Number of data bits, number of stop bits, parity options and baud rate are all selectable from the front panel of the exciter through the keypad from the CONFIG - REMOTE menu. The selected values take effect immediately when changed and are stored in non-volatile memory.

Figure 3-9 Serial Bus Character Format.

3-8.3.2.2 Serial Bus Interface Status Messages. Interface status messages contain error status information caused by a previous command message or other source. When the exciter is in the acknowledge mode, it will respond to all command messages (except X and V) with an interface status message unless the command explicitly requested a status message.

3-8.4 Serial Bus Message Protocol. The interface system operates in one of two modes: normal, or acknowledge. These modes are selected by sending the exciter the appropriate interface command message. Each mode is discussed in the following paragraphs:

3-8.4.1 Serial Bus Normal Mode. In Normal Mode the exciter unit will process messages that are addressed to it but no response will be sent back unless the Command Message was a request for Status Message (Exciter or Interface). The controller can verify that its Command Message(s) was received without error by sending a Command Message requesting a reply Status Message either immediately after sending the original Command Message, or after having sent Command Messages to other exciter units. This mode allows the fastest throughput of commands to a large group of exciters because the controller does not have to wait for each exciter unit to process the message(s) before moving on to the next exciter unit.

3-8.4.2 Serial Bus Acknowledge Mode. In Acknowledge Mode a exciter unit will always respond to Command Messages with a Status Message after it has processed the Command Message (except for the X and V commands). If the Command Message was for a reply Exciter Status Message, and no errors or faults have been detected, the reply will be the requested Status Message. In all other cases, the exciter unit will respond with an Interface Status Message. This mode reduces maximum throughput because the controller must wait for the reply Status Message before issuing another command, but it simplifies the controller's job when it wants to verify the reception of its Command Messages and maximum throughput is not needed.

3-8.5 Line Driver Operation. When Bus Sharing is enabled through the exciter's front panel, that exciter's Transmitted Data and Request to Send line drivers are maintained in a high impedance state at all times except when it is required for that unit to transmit. In Normal Mode operation, this only occurs when the unit has received a Command Message that requests a reply Status Message. In Acknowledge Mode, all commands will caused the addressed unit to transmit.

The line drivers will be turned on and placed into the mark state for at least one full character time before the first character (the STX) is transmitted.

3-8.6 Broadcast Address. All exciters equipped with the serial interface will respond to address 255 the same as its actual configured address. This is referred to as the broadcast address. If a single transmission is sent to this address, each exciter on the bus will respond to the commands in the transmission as if they were sent to it individually. This feature may be used to cause a group of exciters to act in unison, or to reduce the time it takes to initialize a group of exciters to a set of common parameters.

The broadcast address must not be used to request status from a group of exciters or when the exciters are operating in the acknowledge mode, since this would cause bus contention as all exciters would reply at the same time. With only one exciter on the bus it is possible for the controller to determine the unit's address by sending a status request to the broadcast address and examining the address field in the reply, since the reply message contains the unit's configured address. This can be used during system integration as a troubleshooting aid.

3-8.7 Serial Bus Message Definition. All messages are ASCII encoded and inserted into the data field of transmissions as defined in paragraph 3-8.2. Messages from the controller may use lower or upper case for all alphabetic characters. The exciter always uses upper case.

Each message that can be sent using the bus controller is listed in the following tables:

- o Table 3-4. Serial Bus Interface Command Messages.
- o Table 3-5. Serial Bus Interface Status Messages.
- o Table 3-6. Exciter Command and Status Messages

Most Exciter Status Messages use the same format as the Exciter Command Message for that parameter. For example, the reply to the Exciter Command Message "G?" (current carrier level setting) is "G+23" in the same format as the Exciter Command Message to change the output gain.

All Exciter Status Messages are made up of fixed length strings so that values may be parsed by counting the characters of the Status Message. Messages which return a numeric value will be padded with zeros on the left to give the same number of characters as the same message with the maximum value. When more than one parameter is being reported, the individual parameters are separated by a blank (space) character.

Table 3-4 Serial Bus Interface Command Messages.

Message	Definition
:NORM	Set NORMAL interface mode
:ACKN	Set ACKNOWLEDGE interface mode
:?	Request Interface Status Message

Table 3-5 Serial Bus Interface Status Messages.

Message	Definition
OK:NORM	No errors, NORMAL Mode
OK:ACKN	No errors, ACKNOWLEDGE Mode
TE:EEPR	Testing error - EEPROM corrupted
TE:POST	Testing error - power on self test error
LE:PRTY	Line error - parity
LE:FRMG	Line error - framing
LE:OVRN	Line error - overrun
IE:OVFL	Interface error - buffer overflow
IE:IVAL	Interface error - illegal value
IE:UNKN	Interface error - unrecognized message
RE:FALT	Exciter error - fault has been detected

Table 3-6 Exciter Command and Status Messages.

Command	Reply	Description
!		Continue operation from a wait condition caused by power on self test (POST) failure. This is the remote control equivalent of "press any key to continue".
ACS?	ACSxy	<p>Request ACIU Tune Mode and Antenna Coupler status (if installed).</p> <p>x = 1 = coupler fault x = 0 = coupler ok y = 1 = coupler tuning y = 0 = not tuning.</p> <p>When the message reply is ACS1x, the PA KEY from the PA CONTROL connector (J5) is always disabled.</p> <p>When the message reply is ACS10, the T-4150/80 sends a PAPI command to the PA-5050A, waits for the PA-5050A to process the command, then does the following:</p> <ol style="list-style-type: none"> 1. Stores the PA-5050A attenuation setting (ATN? reply). 2. Stores the modulation mode of the T-4150/80. 3. Keys the PA KEY to the PA-5050A for 15 seconds maximum. If the PA KEY exceeds 15 seconds, the timeout is cleared by an ACS1x or an ACS00 reply. <p>After a reply of ACS00 or ACS1x, the T-4150/80 restores the modulation mode and sends the ATN command to the PA-5050A to restore the attenuation setting (output power level).</p>
ACT	none	Sends a Rechannel command to the AT-107B (if installed).
ATN?	ATNxxxx	Request PA-5050A attenuator setting (if installed). xxxx is the current front end attenuation setting. (Range 00.00 to 32.00 dB). (XX.xx)
ATNxxxx	none	Sets front end attenuation value in the PA-5050A (if installed) from 00.00 to 32.00 dB in 0.01 dB steps. (XX.xx)
BI? ¹	BIxxxxxxxx	<p>Request the results of the most recent built-in-test-equipment (BITE) test sequence.</p> <p>Each of the n characters represents one of the tests performed when the BITE sequence is performed and is replaced with a 1 to indicate that the test failed or a 0 to indicate that the test passed. Starting with the first (left most) n character, the definition of each test bit is as follows:</p> <ol style="list-style-type: none"> 1. Test freq: 1.95 MHz 2. Test freq: 2.80 MHz 3. Test freq: 4.05 MHz 4. Test freq: 5.85 MHz 5. Test freq: 8.40 MHz 6. Test freq: 12.10 MHz 7. Test freq: 17.40 MHz 8. Test freq: 25.25 MHz

Table 3-6 Exciter Command and Status Messages-Cont.

Command	Reply	Description
BI		Perform the built-in-test-equipment (BITE) test sequence. This command may take several seconds to complete. To see the results of the BITE test, send the BI? command.
BND?	BNDx	Request the PA-5050A low-pass filter band setting (if installed). x is the current low pass filter band setting. Range 0 to 7. This is determined by the frequency command.
C?	C _____	Request report of all parameters that are now different from those reported in the last Exciter Status Message for each parameter.
CFxx		Set selected configuration parameter into non-volatile memory. Replace the xx with one of the following choices:
MDn		Enable or disable mode defaults. Replace the n with 1 to enable or 0 to disable mode defaults.
BSn		Enable or disable bus sharing. Replace the n with 1 to enable or 0 to disable bus sharing.
PSn		Enable or disable the saving/restoring of the front panel parameters when power is removed/applied. Replace the n with a 1 to enable saving or a 0 to disable saving the parameters.
CL		CLear all 250 memory channels to default parameters.
CN?	CN123 or CN---	Request the current channel number. The characters 123 represent the three digits of the current channel number. If the Exciter parameters have been changed since the last channel was recalled the reply message will take the second form with dashes in place of the digits.
CO		Continue a stopped Hop operation.
CRnnn? ¹	F12345678 M* W1234 G+23 D9	Request the parameters stored in channel nnn without recalling that channel. The actual reply will be a single string of characters. The reply is shown on multiple lines here only for readability. The fields of this message are as described for each reply individually. Fields are separated by a single space.
D?	D#	Request current Dwell Time.
D#		Change Dwell Time. # represents a one character number to select the dwell time in seconds after frequency tuning during hop operations. (Range: 0 through 9)

Table 3-6 Exciter Command and Status Messages-Cont.

Command	Reply	Description
EEPCLR		<p>Clear the entire contents of the exciter's non-volatile memory. All user selected configuration items will be set to the original factory values. These values are:</p> <p>All 250 memory channels to default parameters. Front panel parameters stored at power down to default parameters Soft key assignments for bandwidth Mode defaults enabled Mode defaults reset to original values Front panel Local/Remote selection to Remote</p> <ul style="list-style-type: none"> ●Exciter bus address to 000 ●Bus type to RS-232 (serial only) ●Baud rate to 19,200 bps (serial only) ●Line Parameters to 8 bits, no parity, 1 stop bit (serial only) ●Bus sharing On (serial only) <p>Saving of parameters on power down disabled Display intensity to 100% Keypad clicks and beeps enabled Soft key menus shown by default Reference mode to Automatic</p> <p>NOTE: Execute this command with extreme caution! When the exciter changes to the default interface parameters listed above with dots (●), the remote controller will need to change to these values also unless they are already set. Never use this command when more than one exciter is connected to the bus as they will all be set to address 000. Exciter local operation may also be affected by this command.</p>
F?	F12345678	Request current frequency.
F12345678		<p>Change exciter operating Frequency. Digits 1 through 8 represent the eight digits of the exciter operating frequency with 1 representing the most significant (10 MHz digit) and 8 representing the least significant digit (1 Hz). (Range: 1.6 to 30 MHz or F01600000 through F30000000). If the PA-5050A is installed, the PAF12345678 command is also sent to the PA-5050A (refer to the PA-5050A technical manual).</p>
(cont)		

Table 3-6 Exciter Command and Status Messages-Cont.

Command	Reply	Description
FA? ¹	FAnnnnnnnnnnnnnnn	<p>Request a report of all accumulated faults. The 16 n characters indicate the accumulated status of the fault conditions with each n replaced with a 1 to indicate the fault is true or a 0 to indicate that the fault is not true. Starting with the first (left most) n character, the definition of each fault bit is as follows:</p> <ol style="list-style-type: none"> 1. Software error interrupt has occurred 2. Fault detected in RF Analog Module 3. Fault detected in Synthesizer Output/Fine Loop 4. Fault detected in Synthesizer Step Loop 5. Fault detected in Power Supply Module 6. DSP processor not responding to requests 7. EEPROM does not accept programming 8. Serial bus time-out Fault (check CTS if bus sharing is disabled) 9. GPIB timeout: ready to talk but not addressed 10. GPIB timeout: got talk address but no handshake 11. Serial bus UART detected overrun error 12. Serial bus UART detected parity error 13. Serial bus UART detected framing error 14. Illegal bus address for bus type 15. Not currently used 16. Not currently used
FC? ¹	FCnnnnnnnnnnnnnnnn	<p>Request a report of all current faults. Indicates current fault status (Refer to FA? above).</p>
FLT?	FLTxxxxx	<p>Request the PA-5050A fault status (if installed). xxxxx is fault status of each power module in the format: Driver; PA1; PA2; PA3; PA4. 1=FAULT 0=NONE. This is a logical or of the gain failure and the over temp failure (OT?).</p>
FR?	FR#	<p>Request current Fast Recall mode. FR1=on, FR0=off</p>
(cont)		

Table 3-6 Exciter Command and Status Messages-Cont.

Command	Reply	Description
FR#		<p>Turn Fast Recall mode on/off. # represents a one character number to turn the Fast Recall mode on or off. Where 0 = off, and 1 = on. The fast recall mode permits cycling between stored channels within the memory of the exciter using the remote bus to step channels. The facility makes use of the standard recall facilities within the exciter, but enables them to be done faster than otherwise possible.</p> <p>The speed is made possible by preventing certain display operations during recall. The display reverts to a "Fast Recall" display using minimum graphics when in remote. Only the channel and frequency are updated to the display with a special fast format.</p> <p>When enabled, the exciter will not accept commands to change operating mode or bandwidth. The HOP (SC###) mode may not be entered. If any of these commands are sent, a command not allowed fault will be generated.</p> <p><u>RELEVANT COMMANDS</u></p> <p>FR0 or K - Turn off fast recall mode FR1 - Turn on fast recall mode T0 - Turn transmitter off remotely T1 - Turn transmitter on remotely RCnnn - Recall stored parameters in channel number nnn. (Leading zeros may be omitted)</p> <p><u>Notes On Usage</u></p> <ol style="list-style-type: none"> 1. The remote/local switch on the front panel must be set to remote. When exiting or entering local or remote, the exciter is turned off. 2. The command FR1 is sent to turn on the fast recall mode. The change in display format will be noted when FR1 is sent. 3. RC1 will recall any settings previously stored in channel 1 and automatically commence transmitting within 2 msec. of receipt of the RC1 command. Faster operation is available when the modulation and filter associated with the recalled channel is the same as the previous channel. 4. Subsequent fast recalls to RC2, RC10, RC6, etc., can be made in any order. 5. Enabling/disabling local mode by front panel turns on/off the special display. 6. The command FR0 exits fast recall and returns the display to normal. 7. The exciter output can be disabled at any time using the T0 command. In order to retransmit, a T1 command must be sent. <p><u>Example Sequence</u></p> <p>FR1T1RC1 RC2 RC10 etc. etc.</p>

Table 3-6 Exciter Command and Status Messages-Cont.

Command	Reply	Description
FWD?	FWDxxxx	Request PA-5050A forward power (if installed). xxxx is measured forward power in watts. Range of 0 to 1999 watts.
G?	G±23	Request current Carrier Level setting.
G±23		Change Carrier Level. Digits 2 and 3 represent the significant figures of the carrier gain in dBm. (Range: -33 through +27).
ID? ¹	(-----)	Request an identification message from the control processor. The reply to this command is a message that identifies the manufacturer, the equipment name, the firmware version number and date, and a copyright notice. This message is less than 125 characters in length.
IDD? ¹	(-----)	Request an identification message from the DSP processor. The reply to this command is a message the gives the date and version number of the firmware in the DSP processor. This message is less than 80 characters in length.
IS?	IS#	Request the audio input source.
IS#		Set the audio input source. # is replaced as follows: 0 = MIC, 1 = LINE, 2 = 1 kHz, and 3 = noise
K		Cancel. Stops hop operation and clears all hop parameters.
KEY?	KEYx	Request PA-5050A transmitter key status (if installed). x is the transmit key status. 1=KEYED 0=IDLE
M?	M***	Request current modulation mode. Reply is the same as ** description below except a response of FSK for FS, and FAX for FX.
M**		Change exciter modulation mode. ** represents a one or two character code chosen from the following set: L for LSB, LF for LSBfc, LP for LSBpc, U for USB, UF for USBfc, UP for USBpc, I for ISB, C for CW, A for AM, F for FM, FX for FMfax, and FS for FSK. When the mode is changed, some of the other exciter parameters are set to new values as defaults. If these other parameters are also being changed, set the new mode first before changing the other parameters. Refer to table 3-3 for a description of modulation modes.
OT?	OTxxxxx	Request PA-5050A over temp fault status (if installed). xxxxx is over temp shutdown status of each power module in the format: Driver:PA1:PA2:PA3:PA4. 1=SHUTDOWN 0=NORMAL
PA?	PAFxxxxxxxx SWRxx FWDxxxx REVxx ATNxxxx FLTxxxx KEYx BNDx OTxxxxx	Request PA-5050A Status Message (if installed). This will reply with a complete status message of all settings. These are as follows: PAF, SWR, FWD, REV, ATN, FLT, KEY, BND, OT. See individual commands for definition
PAF?	PAFxxxxxxxx	Request PA-5050A frequency (if installed). xxxxxxxx is the frequency in Hz.

Table 3-6 Exciter Command and Status Messages-Cont.

Command	Reply	Description
PAP#	none	<div style="border: 1px solid black; padding: 5px; text-align: center; margin-bottom: 10px;">CAUTION</div> <p>When this command is sent, the exciter and PA-5050A are automatically keyed. The attenuator in the PA-5050A is automatically adjusted to produce the selected RF power level output.</p> <p>This command sets the power output of the PA-5050A (if installed). Valid numbers are 1=100W, 2=500W, 3=1KW. PAP1 is an arbitrary attenuator setting that will produce between 95 and 170 W. PAP2 will adjust the attenuator to get 500W. PAP3 will adjust the attenuator to get 1000W.</p> <p>PAP1 is forwarded to the PA-5050A without modification. If PAP2 or PAP3 is sent to the T-4150/80, a sequence of commands is sent to the PA-5050A. In this case, the PAP1 command is sent, followed by a delay to allow processing time in the PA-5050A. Then the TX KEY is set true, followed by the selected PAP2 or PAP3 command.</p>
PO?!	POnnnnnnnn	<p>Request the results of the most recent power-on-self-test (POST) sequence. The POST sequence includes the BITE test. POST Results: Each of the n characters represents one of the tests performed when the POST sequence is run and is replaced with a 1 to indicate that the test failed or a 0 to indicate that the test passed. Starting with the first (left most) n character, the definition of each test bit is as follows:</p> <ol style="list-style-type: none"> 1. Controller program ROM sum check failed 2. RAM test failed 3. EEPROM CRC test failed 4. DSP processor failed ROM test 5. DSP processor failed external RAM test 6. DSP processor failed internal RAM test 7. DSP processor failed FIFO/DIRECT test 8. BITE test failed
R?!	F12345678 M* W1234 G+23 IS# D9 CN123 FS* SNxy SR1234 X12	Request reply Exciter Status Message of all operating parameters. The actual reply will be a single string of characters. The reply is shown on multiple lines here only for readability. The fields of this message are separated by a space and are described for each reply individually.
REV?	REVxxx	Request PA-5050A reverse power (if installed). xxx is measured reverse power in watts. Range of 0 to 999.
RC###		ReCall operating parameters from memory channel. ### represents the three digits of the memory channel from which to recall the parameters. Recalled data is entered immediately. This command is also used to set the start channel for frequency hopping operation. It is then followed by the sequential recall command (SC###). (Range: 0 through 249)

Table 3-6 Exciter Command and Status Messages-Cont.

Command	Reply	Description
SC###		<p>This activates the frequency HOP function of the exciter by sequentially recalling memory channels. ### represents the three digits of the highest memory channel to be recalled. The recall begins at the memory channel most recently recalled with the RC### command. (Range: 0 through 249). The exciter will stop on a memory channel for the dwell time stored in the current channel, and then recall the next channel. All channel parameters including frequency, bandwidth, power etc. are changed in the exciter when the next channel is recalled.</p> <div style="text-align: center; border: 1px solid black; padding: 5px; width: fit-content; margin: 10px auto;"> CAUTION </div> <p>Since the exciter is keyed every time the channel is changed during this operation, the HOP function should only be used with external equipment designed for this function. If frequency separation between channels is too great, damage to the external power amplifier and/or antenna system may occur due to high and rapid VSWR fluctuations.</p>
SELCAL Option Command		<p>The Selcal (Selective call) system is used with the RS-232 serial bus. Each time the Selcal command is sent, the exciter sends two sets of two simultaneous audio tones. This can be four different tones, four of the same tones, or any combination of tones. (See Note 2)</p>
SG?	SGbbbbbbb	<p>Request the reason for the last generated SRQ (IEEE-488 interface only). Each b character is replaced with a 0 to indicate that the corresponding bit was not the reason for the last SRQ, or a 1 to indicate that the corresponding bit was responsible for the last SRQ. See figure 3-10 for Serial Poll response byte bit positions.</p>
SMbbbbbbb		<p>Set the SRQ mask byte (IEEE-488 interface only). Controls the generation of the SRQ message for each of the conditions in the Serial Poll response byte. Each b represents one bit in the Serial Poll. See Section Three for a description of the Serial Poll response byte. For each b character that is replaced with a 1, that bit will be allowed to generate an SRQ. Bits replaced with a 0 will not be allowed to generate an SRQ. The default condition at power on is to allow all bits to generate SRQ.</p>
SN?	SNxy	<p>Request the current hop/dwell status. The character x will be replaced with one of the following:</p> <ul style="list-style-type: none"> C when the exciter is currently hopping (even if stopped) N when the exciter is not hopping <p>The character y will be replaced with one of the following:</p> <ul style="list-style-type: none"> D when the exciter is dwelling S when the exciter is stopped N when the exciter is not dwelling or stopped

Table 3-6 Exciter Command and Status Messages-Cont.

Command	Reply	Description																																																				
SP		StoP the Hop operation in progress but save parameters.																																																				
SR?	SR####	Request the current hop Rate.																																																				
SR####		Set the rate for frequency hopping operations to #### milliseconds per step. Legal values range from 10 to 5000 in 10 msec increments.																																																				
ST###		STore current operating parameters into memory channel. ### represents the three digits of the memory channel being stored to.																																																				
SWR?	SWRxx	Request PA-5050A VSWR (if installed). xx is in the range of 1.0 to 6.0. i.e. SWR13 indicates a SWR of 1.3:1. This value is not accurate at output power settings less than 50W.																																																				
T#		Turn on/off the exciter. # represents a one character number to turn the exciter on or off. Where 0 = off, and 1 = on.																																																				
TN?	TNxxxx	Request the current frequency of the tone generator (or frequency shift in FSK mode).																																																				
TNxxxx		Set the frequency of the tone generator (or frequency shift in FSK mode) to xxxx Hz. Range = 50 to 6000 Hz.																																																				
W?	Wnnnn	Request current IF Bandwidth.																																																				
Wnnnn		<p>Change exciter IF bandwidth. nnnn is a two to four digit number that represents the IF bandwidth in units of 10 Hz. (e.g. for an IF bandwidth of 2700 Hz, nnnn is replaced with the digits 270). The selected bandwidth must be on the list of available bandwidths below. The range is limited under certain conditions. In ISB mode the bandwidth is fixed and need not be sent. For all other modes other than AM and FM, the maximum bandwidth is limited to 6 kHz.</p> <p>The following is a list of bandwidths available in the T-4150/80 exciter (all bandwidths are in Hertz):</p> <table border="0" style="margin-left: auto; margin-right: auto;"> <tbody> <tr><td>100</td><td>800</td><td>2100</td><td>3400</td></tr> <tr><td>150</td><td>900</td><td>2200</td><td>3500</td></tr> <tr><td>200</td><td>1000</td><td>2300</td><td>4000</td></tr> <tr><td>250</td><td>1100</td><td>2400</td><td>5000</td></tr> <tr><td>300</td><td>1200</td><td>2500</td><td>6000</td></tr> <tr><td>350</td><td>1300</td><td>2600</td><td>7000</td></tr> <tr><td>400</td><td>1400</td><td>2700</td><td>8000</td></tr> <tr><td>450</td><td>1500</td><td>2800</td><td>9000</td></tr> <tr><td>500</td><td>1600</td><td>2900</td><td>10000</td></tr> <tr><td>550</td><td>1700</td><td>3000</td><td>12000</td></tr> <tr><td>600</td><td>1800</td><td>3100</td><td>14000</td></tr> <tr><td>650</td><td>1900</td><td>3200</td><td>16000</td></tr> <tr><td>700</td><td>2000</td><td>3300</td><td></td></tr> </tbody> </table>	100	800	2100	3400	150	900	2200	3500	200	1000	2300	4000	250	1100	2400	5000	300	1200	2500	6000	350	1300	2600	7000	400	1400	2700	8000	450	1500	2800	9000	500	1600	2900	10000	550	1700	3000	12000	600	1800	3100	14000	650	1900	3200	16000	700	2000	3300	
100	800	2100	3400																																																			
150	900	2200	3500																																																			
200	1000	2300	4000																																																			
250	1100	2400	5000																																																			
300	1200	2500	6000																																																			
350	1300	2600	7000																																																			
400	1400	2700	8000																																																			
450	1500	2800	9000																																																			
500	1600	2900	10000																																																			
550	1700	3000	12000																																																			
600	1800	3100	14000																																																			
650	1900	3200	16000																																																			
700	2000	3300																																																				

Table 3-6 Exciter Command and Status Messages-Cont.

Command	Reply	Description
X?	Xab	<p>Request the current remote control status (serial interface only). The reply to this message is different than the X change parameter command.</p> <p>The letter a is replaced with a 1 to signify that remote control is enabled from the remote controller or a 0 to signify that remote control has been disabled from the remote controller, and the letter b is replaced by a 1 to indicate that remote control operation has been selected from the exciter front panel or a 0 to signify that remote control operation has been disabled from the exciter front panel. For the exciter to respond to change parameter commands from the remote controller, both the remote controller and the front panel selections must be enabled (exciter replies X11 to X?).</p>
X*		<p>Switch between local and remote control operation (serial interface only). The * is replaced with the character 0 to enable the exciter front panel and disable all remote change parameter commands (except this command), or the character 1 to enable all remote control commands and disable all front panel keypad input (except the LOC/REM key). The exciter front panel may always override the remote controller by pressing the LOC/REM key until the display shows LOCAL). The power on default state is X1.</p>
<p>NOTES:</p> <p>¹Status request commands marked with this note may not be mixed with any other status requests in a single transmission.</p> <p>²For SELCAL Option Command see addendum 2607-1023-1 (ADDENDUM FOR SELCAL SYSTEM COMMAND)</p>		

3-9 REMOTE OPERATION USING IEEE-488 BUS.

The exciter can be operated under remote control, using an IEEE-488 bus, if the optional IEEE-488 Remote Interface board and bus plate are installed. Select the remote mode by pressing the front panel REM/LOC switch until CTRL:REMOTE appears in the display. When REMOTE is selected, the bus controller determines whether the exciter is in the remote or local mode.

NOTE

The bus controller can command the exciter to enter the local mode. When the controller commands the exciter to enter the local mode, the front panel will display CTRL:LOCAL.

3-9.1 IEEE-488 Bus Description. The IEEE-488 bus uses a party-line bus structure consisting of 16 signal lines. (Refer to table 2-3.) Devices are connected in parallel to the bus and information is passed in a byte serial/bit parallel fashion. Refer to IEEE Std 488-1978 for a complete description of the IEEE-488 bus.

The sixteen signal lines are divided into three major functional groups: bus management lines, handshake lines, and data lines. There are five bus management lines, three handshake lines, and eight data lines. Data and message transfer is asynchronous. Devices connected to the bus may be talkers, listeners, or controller. Multiple controllers may be connected to the bus but only one controller may be in charge at a time. The controller dictates the role of the other devices by setting the ATN (attention) line true and sending the talk or listen addresses on the data lines. While the ATN line is true, all devices must listen to the data lines. When the ATN line is false, only devices that have been addressed will actively send or receive data. All others ignore the data lines.

Several listeners can be active simultaneously but only one talker can be active at a time. Whenever a talk address is put on the data lines (while the ATN is true), all other talkers will automatically be unaddressed.

The bus management lines conduct an orderly flow of information across the bus. The five bus management signals are defined in table 3-7.

The three handshake lines coordinate the transfer of data over the bus. Transfer is asynchronous and the transfer rate automatically adjusts to the speed of the source and acceptor. The transfer rate will be that of the slowest active device. The three handshake lines are defined in table 3-8.

The eight bidirectional data lines (D1 - D8) transfer the data bytes on the bus. The bus management signals determine which device sends and which devices receive the byte. The handshake lines determine how long the byte remains on the bus.

One 24-pin, D-type ("Blue Ribbon") interface connector provides parallel connection for the exciter. A maximum of fifteen devices, including the bus controller, may be connected to the bus. (Each CDR-3250/80 chassis is counted as one device.) Each exciter must have a unique address set on the front panel.

The exciter may act as a talker and a listener. The SRQ function is selectable by means of a switch on the rear panel. If the SRQ function is disabled, the exciter can not request controller attention for communication. Two other switches on the rear panel are used to select the unaddressed talk only and listen only modes.

3-9.2 Device Capabilities. The interface capabilities implemented in the exciter as listed in table 3-9.

3-9.3 Talking and Listening. Commands sent to the exciter are prefixed with the appropriate Listen Address message and then the message sent in ASCII as detailed in table 3-6. Following the transmission, "Unlisten" message may be sent or another transmission may be sent while the unit is still addressed. Each transmission must end with CR (carriage return) character. In addition, *the EOI (End or Identify) line must be set true concurrently with the CR.* An example of the bus transaction necessary to change the receive frequency to 12.345 MHz is as follows:

```
<Listen Address> F 1 2 3 4 5 0 0 0 <CR with EOI>
```

The unit's configured remote control address serves as both its Talk Address and its Listen Address, and may range from 0 to 30. Multiple exciters may be addressed as listeners and will all accept message transmissions simultaneously when so addressed.

If the message sent to an exciter is a request for status (all messages that end with "?") the exciter will prepare a reply message and wait to be addressed as a talker. If the exciter does not receive its talk address within 5 seconds of the request for status, it will indicate a fault and stop waiting. If it receives the talk address within 5 seconds, it will perform the source handshake with the controller until all of the reply message has been sent. If the controller does not perform the acceptor handshake within 1 second of sending the talk address to the exciter, the exciter will time out, indicate a fault, and stop and return to normal operation. The exciter will assert the EOI line on the bus concurrently with sending the CR at the end of the status message. It is not recommended that request for status messages be sent to multiple exciters simultaneously.

Table 3-7 IEEE-488 Bus Management Signals.

Name (Mnemonic)	Description
Attention (ATN)	Causes all devices to interpret data on the bus as a controller command. When ATN is true, the bus is placed in the "Command Mode". All devices on the bus interpret data on the eight data lines as commands. When ATN is false, the bus is placed in the "Data Mode". All active listeners on the bus interpret data on the eight data lines as data.
Interface Clear (IFC)	Clears the bus. Sets the bus to an idle state.
Service Request (SRQ)	Alerts the controller to a need for communication.
Remote Enable (REN)	Enables devices to respond to remote program control when addressed by the controller.
End or Identify (EOI)	Indicates last byte of multibyte sequence.

Table 3-8 IEEE-488 Bus Handshake Lines.

Name (Mnemonic)	Description
Data Valid (DAV)	Sent by source to indicate that data on the bus is valid. All active devices on the bus can accept the byte as true information.
Not Ready for Data (NRFD)	Sent by acceptor to indicate that a device is not ready to accept data.
Not Data Accepted (NDAC)	Sent by acceptor to indicate that the data byte has not yet been read from the bus.

Table 3-9 IEEE-488 Implemented Interface Capabilities.

Mnemonic	Description
SH1	Source Handshake, complete capability
AH1	Acceptor Handshake, complete capability
T6	Basic Talker, with serial poll and unaddress if MLA, no Talk Only mode
TE0	No Extended Talker
L4	Basic Listener, unaddress if MTA, no Listen Only mode
LE0	No Extended Listener
SR1	Service Request, complete capability
RL2	Remote Local, no local lockout
PP0	Parallel Poll, no capability
DC1	Device Clear, complete capability
DT0	Device Trigger, no capability
C0	Controller, no capability
E2	Three state line drivers

3-9.4 SRQ and Serial Poll Response. The exciter will assert the Service Request uniline message (SRQ) when any of several conditions occur. The status of each of these conditions is given in the Serial Poll response byte. The conditions and their location in the Serial Poll response byte are shown in figure 3-10.

The Fault and Local Control bits will generate an SRQ on the bus whenever that state changes, either from true to false or from false to true. Both Bad Message and Bad Value bits are cleared upon receipt of a valid command message.

When an SRQ message is received by the controller, each device on the bus should be Serial Polled to determine which device is requesting service. Bit 6, the SRQ bit will be sent as true by any device that is currently asserting the SRQ message. The controller may execute a Serial Poll with the exciter at any time to read its status.

It is possible for an SRQ to be generated and for the Serial Poll to show no change in status from previous polls. This can happen if the state of a bit has changed and then changed back before the poll is taken. For example, if a fault is detected and then goes away before the poll is read, the bit will still be read as false. This condition may be detected by sending the SG? status request. The reply to this status message is of the following form: SGbbbbbbbb where each b character in the reply corresponds to a bit in the serial poll response byte. If the b bit is a 1, that bit is the one that caused the last SRQ message.

Each bit of the serial poll response byte may be masked off to prevent it from generating an SRQ message on the bus. This message is of the form: SMbbbbbbbb where each b is replaced with a 1 to allow that bit to generate an SRQ or a 0 to 'mask off' that condition and prevent an SRQ from being generated. For example to allow all conditions to generate an SRQ except the Fault condition, send SM11111101. The default (power-on) status of this message is to allow all bits to generate an SRQ.

3-9.5 Device Clear And Selected Device Clear Response. When the exciter receives the Device Clear (DCL) command or the Selected Device Clear (SDC) command, the exciter responds in the same way as if it had received the K command. This command stops any pending sweep or scan condition and places the exciter into the normal state.

3-10 POWER UP AND TESTING CONSIDERATIONS.

Whenever power is applied to the exciter it will execute a Power On Self Test sequence. This sequence tests several functions inside the exciter including memory tests, DSP processor memory test, a confidence test of the configuration options stored in non-volatile memory, and a BITE (built in test equipment) test of exciter functions. If any of these tests fails, the exciter will not enter into normal operation, but will wait for an operator action to ensure that any failures will not go unnoticed. From the front panel, the display will show the message "Hit any Key to Continue". Since it is often required that the exciter not send any unsolicited bus messages, exciters configured with the serial interface will not announce this wait condition over the bus. IEEE488 units will assert the SRQ line and set bit 3 of the Serial Poll response byte. During this wait condition, the exciter will only respond to a limited subset of commands from the bus. These are:

: ?	Request interface status message (serial only)
Serial Poll	Sent in response to a SRQ (IEEE-488 only)
PO?	Request results of Power On Self Test
!	Clear wait condition and proceed with startup

For serial interface units in this wait condition, if the :? command is sent, the exciter will respond with:

TE:EEPR or TE:POST

This indicates that the exciter is waiting. IEEE-488 units will indicate this condition in bit 3 of the Serial Poll response byte. This condition can only be cleared by sending the ! command or by pressing any key on the front panel. To determine the reason for POST failure, the user should then request POST results (PO?) and if this shows BITE failure, also request the BITE results (BI?) after clearing the Power on Wait condition with the ! command.

The proper way to structure a remote control program to handle this condition is to query each exciter for interface status (:? or SRQ/Serial Poll) before sending any other commands at power up and wait for the reply. A reply will not be sent until a wait condition has been entered or normal operation has been entered. If the wait condition is indicated, send the ! command and test again. This process should be repeated until the exciter responds with an interface status other than TE: (serial interface) or shows Serial Poll bit 3 clear (IEEE488 interface).

3-11 EEPROM CLEARING.

If a POST failure was caused by a corrupted EEPROM (Interface Status TE:EEPR), send the **EEPCLR** command to clear the entire EEPROM to default values. This will cause the remote interface parameters to revert to the factory defaults which may be different than those that were selected from the front panel. In this case, the remote interface may become inoperative, and the desired remote interface parameters will have to be re-entered from the front panel.

The factory default remote interface parameters for the serial interface are as follows:

Address	000
Baud Rate	19,200 bits per second
Bits	8 bits, 1 stop bit, no parity
Bus Type	RS-232
Bus Sharing	enabled

For units configured with the IEEE-488 interface, only the address parameter is significant.

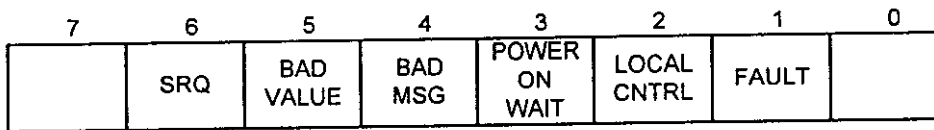

- FAULT** This bit mirrors the status of the front panel FAULT annunciator.

- LOCAL CNTRL** When true, this bit indicates that the front panel LOC/REM switch has selected LOCAL operation, overriding the remote control bus.

- POWER ON WAIT** This bit indicates that the exciter has failed the Power-On Self Test and is waiting for a front panel key press or the remote control ! command.

- BAD MSG** The last command message was not recognized as a valid command.

- BAD VALUE** The last command message was recognized, but contained an out of range numeric value.

- SRQ** The exciter is asserting the SRQ message on the bus when this bit is true.

Figure 3-10 IEEE-488 Serial Poll Response Byte.



CHAPTER 4 GENERAL THEORY OF OPERATION

4-1 INTRODUCTION.

This chapter contains a block diagram description of the T-4150/80. Each of the boards/modules are discussed in the paragraphs below: (See figure FO-2.)

4-2 BLOCK DIAGRAM DISCUSSION.

4-2.1 AC Receptacle/RFI Filter. The AC Receptacle/RFI Filter or optional locking connector provides connection of input power. AC power line filtering is only provided on the T-4180.

4-2.2 AC Line Filter. The AC Line Filter board provides additional power line filtering and keeps internally generated power supply switching noise off the AC input line. When the front panel power switch (S1) is set on, power is applied to the POWER SUPPLY module through the AC Receptacle/RFI Filter, the circuit breaker (CB1) on the rear panel, and the AC Line Filter board.

4-2.3 Power Supply Module. The POWER SUPPLY module is a switching regulated type that provides +8, +17, and -17 VDC to the exciter modules through the motherboard using 90 to 270 VAC input power (automatically sensed). A separate +12 volt output is used for the fan on the rear panel. Fault detector circuits send a fault signal to the Control Section in the Digital module if any of the voltages fall below a preset level.

4-2.4 Front Panel. The Front Panel contains a microphone/key jack, power ON/OFF switch, main adjustment knob, 19-key conductive rubber keypad, and full graphic vacuum fluorescent display. Each of the assemblies are described below.

4-2.4.1 Main Adjustment Knob. The Main Adjustment Knob allows exciter parameter entry using a knob, instead of a keypad. This provides faster and easier operator entry for most parameters. The knob contains an optical shaft encoder that converts shaft rotation information into digital data for the Control Section in the Digital module. The encoder produces two signals used to determine the amount and direction of knob rotation.

4-2.4.2 Keypad Board. The Keypad board contains 19 conductive rubber keys accessible on the front panel that provide key press data to the keypad encoder in the Control Section in the Digital module. When a key is pressed, ground is applied to a 5-column, 4-row matrix providing a separate column and row signal to the keypad encoder in the Control Section in the Digital module.

4-2.4.3 Display Module. The Display module is a full graphic vacuum fluorescent display containing a 256 x 64 pixel matrix. Display data from the Control Section in the Digital module directly provides display information to an internal display controller which in turn drives the display.

4-2.5 Digital Module. The Digital module contains two major sections: the Control Section, and the DSP Section. Each of these sections is described below.

4-2.5.1 Control Section. The Control Section governs all aspects of the exciter's operation. The Control Section receives commands from the operator through the keypad or from the optional remote control bus, and provides status and data information to the operator through the front panel display and the remote control bus. All exciter operating parameters, such as frequency, modulation mode, and power level are directly controlled by the Control Section. In addition, the Control Section can store up to 250 different sets of operating parameters into memory channels. These memory channels can be recalled individually, or scanned sequentially for frequency hopping. The current operating parameters and the 250 memory channels are stored in non-volatile memory and are retained when power is removed.

The Control Section contains a microprocessor containing a 16-bit internal data bus, with an 8-bit external bus. The clock frequency is 16 MHz using an external 32 MHz crystal. The program is stored in a 128k x 8-bit flash memory, and data memory consists of a 32k x 8-bit static RAM IC. Channel memory and other miscellaneous non-volatile storage requirements are provided by an 8k x 8-bit EEPROM.

An encoder logic circuit receives data inputs from the front panel adjustment knob optical shaft encoder. The shaft encoder is mounted on the shaft of the knob and produces two signals used to determine the amount and direction of knob rotation. The keypad encoder provides the interface between the front panel keypad and the Control Section. A key press is sensed as an interrupt input to the processor. The full graphic vacuum fluorescent display in the front panel contains a processor bus interface connecting directly to the buffered data bus.

I/O ports provide all processor output to the analog and DSP sections of the exciter. D-latches are clocked by decoded addresses gated with a processor write signal. Some of these latched output lines are grouped together as enable, clock, and data lines and are operated by the

processor as synchronous serial ports. Other latched output lines are used as direct control signals.

I/O signals include:

FAULTs	Input from the circuits indicating a fault condition.
BITE DET	Input from RF Analog module to determine if BITE signals pass completely through exciter circuits.
CMD FLAG	Informs the DSP Section that the command register contains a CMD MSG ready for transfer.
CMD MSG	Control data from the Control Section to the DSP Section.
STATUS MSG	Exciter status information (frequency, modulation mode, etc.) from the DSP Section.
STATUS RDY	External flag interrupt to inform the Control Section that the DSP Section's output register contains the STATUS MSG for transfer.
ENABLE	Enables each exciter module or circuit.
CLOCK	Clocks out the control data to all modules.
DATA	Control information to each module or circuit.
MIC/CW KEY	From front or rear panel to key the exciter. (Note: The CW key is operational in both local and remote modes of operation.)
PA KEY	Keys the external power amplifier.
PADAT	External power amplifier data.
TX KEY	Keyline for external equipment.

Either a serial or IEEE-488 remote interface plug-in daughter board is installed as the remote control option. If the exciter is configured for serial bus operation refer to paragraph 4-2.6. If the exciter is configured for IEEE-488 bus operation refer to paragraph 4-2.7.

4-2.5.2 DSP Section. The DSP section is comprised of a two-channel audio analog-to-digital (A/D) converter, a TMS320C31 programmable digital signal processor (DSP) 64Kx32 static RAM, 128Kx8 flash memory for program storage, an A/D converter for automatic level control (ALC) and a digital-to-analog converter (DAC) for signal generation.

The input signals from the Normal and Alternate channels are multiplexed into one A/D converter where they are converted to digital samples and transferred to the DSP. In all modulation modes, except for ISB, the Alternate channel data is ignored. The Normal channel is checked, and if necessary, regulated to avoid over-modulation, then applied to the equations appropriate to the selected type of modulation. The carrier is created at 24 kHz \pm 500 Hz in 1 Hz steps, according to the operator frequency selection. Steps of 1 kHz and larger are provided by the synthesizer for the final up-conversion LO.

The basic modulations provided are AM with full carrier, USB suppressed carrier, LSB suppressed carrier, FM, and on-off keyed CW. In addition, ISB provides simultaneous USB from the Normal channel input and LSB from the Alternate channel input. With the exception of the highpass filter used to reject DC on the input channels, all digital filtering is done with symmetrical finite-impulse-response filters (FIR), leaving no group delay distortion.

The digitally created signal is converted to an analog signal via a 16-bit D/A converter operating at 192 kilosamples per second. The resulting signal is filtered in a 10-pole active lowpass filter. The resulting analog signal at approximately 24 kHz is applied to the RF Analog module as the 1ST IF.

The output signal amplitude is controlled by regulating the size of the digital signal as created in the DSP. When operating with a power amplifier having an analog level detector, the automatic level control (ALC) signal is converted to digital form in a separate A/D converter, and used by the ALC algorithm to regulate the output level.

4-2.6 Serial Bus (Optional). If the unit is optionally configured for serial bus remote control operation, the unit will contain the Serial Bus Remote Interface Board and the Serial Bus Cable Assembly. Each is described in the following paragraphs.

4-2.6.1 Serial Bus Remote Interface Board. The Serial Bus Remote Interface Board converts serial data from the bus to parallel data for the Control Section. It also converts parallel data from the Control Section to serial data for the serial bus. This board is installed at the factory as a plug-in daughter board in the Digital module, and uses a serial receiver-transmitter integrated circuit. The board contains

line drivers and line receivers for both RS-232 and RS-422 bus types.

4-2.6.2 Serial Bus Cable Assembly. The optional Serial Bus Cable Assembly allows connection of the Serial Bus Remote Interface board to the rear panel, and contains a multipurpose connector for operation of either a RS-232C or RS-422A external serial bus.

4-2.7 IEEE-488 Bus (Optional). If the unit is optionally configured for IEEE-488 bus remote control operation, the unit will contain the IEEE-488 Remote Interface Board and the IEEE-488 Cable Assembly. Each is described in the following paragraphs.

4-2.7.1 IEEE-488 Remote Interface Board. The optional IEEE-488 Remote Interface Board contains an IEEE-488 controller, line transceivers, and associated circuits to provide a smooth and orderly flow of data between the Control Section in the Digital module and the external IEEE-488 bus. This board is installed at the factory as a plug-in daughter board in the Digital module.

4-2.7.2 IEEE-488 Cable Assembly. The optional IEEE-488 Cable assembly allows connection of the IEEE-488 Remote Interface Board to the rear panel, and contains a D-type connector for connection to the external bus.

4-2.8 Synthesizer Module. The synthesizer module provides the 3RD LO frequency used for signal frequency conversion. It also contains the reference frequency circuits for reference frequency generation and switching, and audio circuits for audio amplification and control.

Using the +8V, +17V, and -17V from the power supply, five internal voltage regulators (not shown) supply the required voltages to the entire module. Three of these regulators are mounted directly to the module surface for optimum heat transfer.

4-2.8.1 Control. The serial control DATA from the digital module is clocked through a buffer into the fine phase-locked loop (PLL) circuits and through a shift register to the step loop PLL and audio circuits. At the proper time, the DATA is latched into the PLL circuits by the correct SYNTH ENABLE signal. The ENABLE signal also latches the data into the shift register for the audio section. The data latched into the PLL circuits is used to synthesize the desired frequencies from the 10 MHz reference. One bit in the shift register selects the correct audio source.

4-2.8.2 Reference Frequency. The reference frequency source is automatically selected by a detector that senses the presence of an external reference signal. If the external

reference is detected, it is used as the basis for the frequency generation. If the external reference is not sensed, the internal oscillator (TCXO or optional OCXO) is used for frequency generation. A potentiometer is used to adjust the internal reference if necessary. One path of the internal or external reference frequency signal is amplified and applied to the RF Analog module. The other path is split and used as the reference frequency for the fine and step loop PLL circuits.

4-2.8.3 3rd LO Generation. The output loop circuits produce the 3rd LO signal for the third mixer circuits using the FINE LOOP and STEP LOOP inputs.

The frequency of the output loop VCO is controlled by mixing the VCO output with the STEP LOOP frequency. The resultant difference signal is frequency and phase compared with the FINE LOOP frequency to produce the output PLL DC control voltage.

The output loop VCO signal takes two paths. One path is filtered and becomes the 3RD LO signal. The other path is mixed with the STEP LOOP signal, producing a difference frequency. The difference frequency is filtered through a lowpass filter and applied to a phase/frequency detector circuit through a wrong-side lock detector.

The wrong-side lock detector ensures the output frequency locks only to the difference of the STEP LOOP minus the VCO output frequency. If the VCO frequency is higher than the step loop frequency, the circuit disables the difference frequency which causes the DC correction voltage to drive the VCO to a lower frequency. The phase/frequency detector compares the difference frequency with the FINE LOOP frequency and develops a DC control voltage through a loop filter keeping the VCO on frequency. The signal leaves the module as the 3RD LO at 42.055 - 70.455 MHz in 1 kHz steps.

A fault detector sends the OUTPUT/FINE or STEP FAULT signals to the digital module if the output or fine loops, or step loop lose lock.

4-2.8.4 Audio. The audio board is located in a separate shielded compartment in the synthesizer module. The shielding prevents interaction between the high-level audio and sensitive VCO circuits.

Audio is applied from either the front panel MIC/KEY jack or the rear panel NORM (upper sideband), or ALT (lower sideband) balanced inputs. The audio from each of these inputs is applied directly to amplifiers. A switch controlled by the data from the digital module selects either the microphone or normal line input. After amplification, the audio is filtered using lowpass filters with an 8 kHz bandwidth.

The audio leaves the board as the NORM AUDIO and ALT AUDIO signals for application to the DSP section in the Digital Module to modulate the RF signal.

4-2.9 RF Analog Module. The RF Analog module contains the first mixer, 1st LO/DSP clock, second mixer, second LO, third mixer, third LO driver, and postselector circuits. Each section is discussed below.

4-2.9.1 First Mixer. The first mixer section converts the modulated 24 kHz input signal (1ST IF) from the DSP section to the second intermediate frequency (2ND IF) of 456 kHz. The signal is mixed with the 480 kHz 1ST LO frequency from the 1ST LO/DSP Clock circuits producing the 2ND IF. A bandpass filter at the output of the first mixer ensures that only the 2ND IF will pass.

4-2.9.2 1ST LO/DSP Clock. The 1ST LO/DSP Clock circuit provides two fixed frequencies. The circuit uses a 48 MHz VCO phase locked to the 10 MHz reference. The VCO signal is split and applied to the DSP circuits through a lowpass filter, and to a ± 100 circuit to generate the 480 kHz 1ST LO.

A fault detector sends the RF FAULT signal to the Digital module if the loop loses lock.

4-2.9.3 Second Mixer. The second mixer section converts the 2ND IF at 456 kHz, to the 3RD IF of 40.456 MHz. The 2ND IF signal enters the section and is applied to the 2nd mixer. The 3RD IF at 40.456 MHz is produced by mixing the 2ND IF at 456 kHz with the 2ND LO frequency at 40.000 MHz. The signal is amplified, filtered, and applied to the third mixer. The external RF DISABLE signal provides a means to rapidly interrupt the signal path under certain operating conditions if desired.

4-2.9.4 Second LO Driver. The second LO driver operates at a fixed frequency of 40.000 MHz. This frequency is derived by applying the 10 MHz reference signal to a pair of cascaded bipolar transistor frequency doublers. The second doubler is followed by a bandpass filter. The filter output is applied to the second LO driver in the second mixer circuit.

4-2.9.5 Third Mixer. The third mixer section converts the 3RD IF to the RF OUT using the third LO signal. The 3RD IF signal enters the section and is applied to the 3rd mixer. The RF OUT at 1.6 - 30.0 MHz is produced by mixing the 3RD IF at 40.456 MHz with the 3RD LO frequency at 42.055 - 70.455 MHz. The signal is amplified and applied to a lowpass filter to ensure only signals below 30 MHz will pass. After additional amplification, the RF OUT signal is applied to the Postselector.

4-2.9.6 Third LO Driver. The 3RD LO signal is tuned to the correct frequency depending on the transmit frequency and transmit modulation mode selected. The 3RD LO driver consisting of a preamplifier and output amplifier, provides the proper level 3RD LO signal to the 3RD mixer. A fault detector sends the RF FAULT signal to the Digital Module if the 3RD LO signal level falls below a preset level.

4-2.9.7 Postselector. The postselector assembly consists of eight automatically selected bandpass filters, and an RF amplifier. Control data from the Control Section in the Digital module automatically selects the correct filter for the selected transmit frequency using PIN diode switches. The serial control DATA from the Control Section is clocked into the shift register circuit. At the proper time, the DATA is latched into the shift register by the RF ENABLE signal. The shift register data then selects the correct filter.

Built-in test equipment (BITE) testing is provided by disconnecting the antenna signal and applying the RF output to a detector circuit. One frequency per postselector band is used to check the exciter circuits and each postselector band. The frequencies used are: 1.95, 2.80, 4.05, 5.85, 8.40, 12.10, 17.40, and 25.25 MHz. If a signal is not detected after a certain period of time, the test fails and the Control Section in the Digital module causes a fault to be displayed on the front panel.

CHAPTER 5 MAINTENANCE INSTRUCTIONS

Section I. PREVENTIVE MAINTENANCE

5-1 INTRODUCTION.

This chapter contains both preventive and corrective operational level maintenance instructions. The information includes cleaning and lubrication, inspection, performance verification, troubleshooting, and subassembly removal and replacement.

5-2 CLEANING AND LUBRICATION.

Clean the external surfaces and front panel of the unit every 2 weeks using a vacuum cleaner or small soft brush to remove any dirt or dust. Do not use any cleaning agents. There are no lubrication requirements.

5-3 INSPECTION.

If the unit is faulty or suspected to be faulty perform a visual inspection as follows:

5-3.1 External Inspection.

1. Check front panel for physical damage.
2. Check external case for physical damage.
3. Check rear panel for physical damage.
4. Check rear panel connectors for corrosion and loose connectors.
5. Check rear panel cables for frayed or broken wires.

5-3.2 Internal Inspection.

WARNING

With the front panel power switch set OFF and the power cord plugged into the power source, high voltage shock danger is present internally at the rear panel POWER receptacle/RFI filter, AC Line Filter board, rear panel circuit breaker, and the front panel power switch connections.

CAUTION

When working on the exciter with covers removed and power applied, do not allow tools or metal objects to come in contact with exciter components. Equipment damage may occur.

CAUTION

Unit contains parts and assemblies sensitive to damage by electrostatic discharge (ESD). Use ESD precautionary procedures when touching removing or inserting parts.

1. Turn the unit off, and remove the power cord from the power source.
2. Using a no. 1 Phillips screwdriver, remove 4 screws from both sides of chassis for each cover to be removed, and then remove the cover.
3. Check for loose modules and circuit boards.
4. Check for loose connectors, corrosion, or burn marks.
5. Check for frayed or broken wires.

5-4 PERFORMANCE VERIFICATION.

WARNING

With the front panel power switch set OFF and the power cord plugged into the power source, high voltage shock danger is present internally at the rear panel POWER receptacle/RFI filter, the AC Line Filter board, rear panel circuit breaker, and the front panel power switch connections.

CAUTION

When working on the exciter with covers removed and power applied, do not allow tools or metal objects to come in contact with exciter components. Equipment damage may occur.

CAUTION

Unit contains parts and assemblies sensitive to damage by electrostatic discharge (ESD). Use ESD precautionary procedures when touching removing or inserting parts.

The following steps provide verification of the exciter output.

1. Connect RF OUT (J3) on exciter's rear panel to Channel 1 input on oscilloscope.
2. Connect Channel 1 output on oscilloscope to Frequency counter.
3. Turn exciter on and set the frequency to 30 MHz, CW modulation, +27 dBm carrier level.
4. Key the exciter and observe a 30 MHz \pm 3 Hz signal (\pm 0.3 Hz with optional OCXO) at approximately 20V p-p.

Section II. CORRECTIVE MAINTENANCE

5-5 TROUBLESHOOTING.

5-5.1 Troubleshooting Philosophy. Certain assumptions are made concerning the troubleshooting approach as applied to the exciter as follows:

1. All point-to-point wiring is correct. Therefore, no malfunction is the result of a wiring (or cable connector) fault.

NOTE

Suspected failure of cables or connectors require visual inspection and continuity tests using the appropriate diagrams. See FO-3, and FO-4 for interconnecting, schematic, and motherboard pin assignments.

2. Malfunctions are non-interactive. Each symptom of a problem is caused by a single malfunction and no additional failures occurred during the troubleshooting process.
3. Multiple faults can be isolated if they are non-interactive.
4. Preventive maintenance has been performed (Section I).

5-5.2 Built-In Tests. The T-4150/80 provides three types of testing: power-on self test (POST), built-in test equipment (BITE), and built-in test (BIT). Each is discussed below.

5-5.2.1 POST. The POST is performed automatically each time the exciter is powered on. Under firmware control, the POST sequences through a series of tests that checks the Control and DSP section of the Digital module, then activates the BITE check. If a failure is detected, the front panel display will show the failure. After recording the failure data, press any key on the front panel keypad to continue with operation. Depending on the failure, exciter functions may or may not be possible. If a BIT fault is detected after the POST, the front panel will show the fault indication in the display. POST results are also reported over the remote control bus.

5-5.2.2 BITE. The BITE check is controlled by the firmware and is a sequence that checks the signal path using eight different frequencies. This test exercises the entire exciter signal path. Different frequencies are used to check each postselector filter. The BITE check is automatically performed during the POST, or may be selected manually at any time from the front panel, or the remote control bus.

5-5.2.3 BIT. During normal exciter operation, fault detectors are operating in the background. Table 5-1 lists the fault detectors, their locations and the fault signal sent to the Control section in the Digital module. If a fault is detected, the Control section stores the information in memory, causes the fault indication to be shown on the display, and sends the fault information over the remote control bus. The operator can view the current or cumulative faults (since power up) using the UTILITY FAULTS soft key menu.

Table 5-1 Fault Detectors.

Detector	Module Location	Fault Signal
Power Supply	Power Supply	PS FAULT
1st LO/DSP Clock	RF Analog	RF FAULT
2nd LO Driver	RF Analog	RF FAULT
3rd LO Driver	RF Analog	RF FAULT
Output Loop PLL	Synthesizer	OUTPUT/FINE FAULT
Fine Loop PLL	Synthesizer	OUTPUT/FINE FAULT
Step Loop PLL	Synthesizer	STEP FAULT

5-5.3 Troubleshooting Procedure. Equipment troubleshooting should be performed in the following order:

1. Fault identification.
2. Initial checks.
3. Front panel display interpretation.
4. Signal tracing (If required).
5. Subassembly replacement.

Refer to the following paragraphs for details:

5-5.3.1 Fault Identification. A fault is usually indicated by a fault indication on the front panel display, the bus controller detecting a fault bit, or by the exciter not transmitting.

5-5.3.2 Initial Checks. Before detailed troubleshooting, perform the following:

1. Check that the display on the front panel is on, and the power switch is on. If the front panel display is off, and the power switch is set to on, ensure that input power is correct.

NOTE

Display may not be visible in bright ambient light if 5% intensity is selected.

2. Check that valid frequency, carrier level, and other parameters are correctly set.
3. Check for correct external reference frequency. If an external reference frequency is used, try disconnecting it, and recheck the exciter.
4. Check that audio input(s) are correct and the exciter is keyed.
5. Check operation in both LOCAL and REMOTE.

5-5.3.3 Front Panel Display Interpretation. Further isolation is done by using the front panel to view the present or cumulative faults. To view the fault from the Primary soft key menu select NEXT, NEXT, NEXT to display the Utility soft key menu. Refer to paragraph 3-7.5.3 for further operation. Table 5-2 lists all fault messages, their meaning, and the maintenance action to take.

5-5.3.4 Signal Tracing. If the failed subassembly cannot be isolated using the initial check or front panel display interpretation, isolate the failed subassembly using conventional signal tracing techniques. Refer to chapter 4 for signal flow descriptions.

WARNING

Observe proper safety precautions when checking RF output signals from the exciter.

CAUTION

Do not check RF output signals from the exciter without proper input attenuation to the test equipment. Damage to the test equipment may occur.

Signals are checked at various locations in the equipment using an oscilloscope (see figures FO-3 through FO-5). Refer to paragraph 5-4 to pass a signal through the exciter for signal tracing. Tables 2-1 through 2-5 lists signals at the rear panel connectors.

Table 5-2 Front Panel Fault Messages.

Message	Meaning	Action To Take
Software Error Interrupt has occurred	Program failure	1. Recycle power 2. Replace Digital Module
Fault Detected in RF Module	2nd or 3rd LO signal not detected in RF Analog Module, or 1st LO/DSP Clock PLL lost lock	1. Check 10 MHz REF signal from Synthesizer Module 2. Replace RF Analog Module 3. Replace Synth Module 4. Check wiring
Fault Detected in Synth: Fine or Output Loop	Fine or Output PLL lost lock	1. Check external reference frequency 2. Check internal reference frequency by applying external reference if available 3. Replace Synth Module

Table 5-2 Front Panel Fault Messages-Cont.

Message	Meaning	Action To Take
Fault Detected in Synth: Step Loop	Step PLL lost lock	<ol style="list-style-type: none"> 1. Check external reference frequency 2. Check internal reference frequency by applying external reference if available 3. Replace Synth Module
Fault Detected in Power Supply Module	Voltage outputs out of tolerance	<ol style="list-style-type: none"> 1. Check input power to exciter 2. Replace Power Supply Module 3. Replace AC Line Filter board
DSP Processor Not Responding to Rqst	DSP section not responding to a request for data from the Control Section.	<ol style="list-style-type: none"> 1. Recycle power 2. Check DSP CLK signal from RF Analog Module 3. Replace Digital Module
EEPROM Does Not Accept Programming	Control Section non-volatile memory will not accept channel data, skip frequencies etc.	<ol style="list-style-type: none"> 1. Recycle power 2. Replace Digital Module
Serial Bus Time-Out Fault - Check CTS	External remote controller has not sent the Clear To Send signal to the Control Section	<ol style="list-style-type: none"> 1. Check remote controller program 2. Replace Digital Module 3. Replace Remote Connector board
Serial Bus UART Detected Overrun Error	Bus line error.	<ol style="list-style-type: none"> 1. Check CONFIG parameters using front panel (must match external remote controller) 2. Check external remote controller configuration parameters 3. Replace Digital Module 4. Replace Remote Connector board
Serial Bus UART Detected Parity Error	Bus line error.	<ol style="list-style-type: none"> 1. Check CONFIG parameters using front panel (must match external remote controller) 2. Check external remote controller configuration parameters 3. Replace Digital Module 4. Replace Remote Connector board.
Serial Bus UART Detected Framing Error	Bus line error.	<ol style="list-style-type: none"> 1. Check CONFIG parameters using front panel (must match external remote controller) 2. Check external remote controller configuration parameters 3. Replace Digital Module 4. Replace Remote Connector board
GPIB: Ready to Talk But Not Addressed	IEEE-488 external remote controller did not send address within allotted time.	<ol style="list-style-type: none"> 1. Check remote controller 2. Replace Digital Module. 3. Replace Remote Connector board.
GPIB: Got Talk Addr But No Handshake	IEEE-488 external remote controller sent the correct address but did not take data from bus in allotted time.	<ol style="list-style-type: none"> 1. Check remote controller 2. Replace Digital Module. 3. Replace Remote Connector board.
Illegal Bus Address for Bus Type	Configured exciter bus address out of limit.	<ol style="list-style-type: none"> 1. Check CONFIG address using front panel. Limits = 000 - 254 serial bus, 00 - 30 IEEE-488 bus.

5-6 SUBASSEMBLY REMOVAL AND REPLACEMENT.

The following procedures describe removal and replacement procedures for subassemblies that may be removed and replaced at the operational level of maintenance:

No internal adjustments or component level maintenance should be performed at the operational level. These functions should be performed at the factory or an authorized repair depot.

WARNING

Turn off power and remove power cord before replacing subassemblies. Personnel injury or equipment damage may occur.

To remove the top or bottom cover, do the following: (Refer to figure FO-5 for locations.)

Using a no. 1 Phillips screwdriver, remove 4 screws from both sides of chassis for each cover to be removed, and then remove the cover.

CAUTION

In the following procedures, to prevent damage to captive Allen screws or screw holes in the chassis, ensure captive Allen screws are completely retracted (but not removed) from module before pulling module from motherboard connector.

CAUTION

Module connectors may be difficult to separate. Pry gently on both sides of the connector to assist module removal.

NOTE

When removing subassemblies, save attaching hardware for subassembly replacement.

5-6.1 Synthesizer Module.

1. Remove top cover.
2. Using a 7/64 inch Allen wrench, loosen 8 Allen screws from module.
3. Pull module from motherboard connector.
4. To replace, reverse removal procedures.

5-6.2 RF Analog Module.

1. Remove top cover.
2. Remove Synthesizer module per paragraph 5-6.1.
3. Using a 7/64 Allen wrench, loosen 8 Allen screws from module.
4. Pull module from motherboard connector.
5. To replace, reverse removal procedures.
6. Replace Synthesizer module per paragraph 5-6.1.

5-6.3 Power Supply Module.

1. Remove top and bottom cover.
2. Using a no. 2 Phillips screwdriver, remove 4 screws and attaching hardware from bottom of module.
3. Lift module from unit to disengage connector.
4. To replace, reverse removal procedures.

5-6.4 AC Line Filter Board.

1. Remove top and bottom cover.
2. Remove Power Supply Module per paragraph 5-6.3 to reach AC Line Filter board attaching screws.
3. Using Phillips screwdriver, remove AC line filter shield.
4. Using Phillips screwdriver, remove 4 screws from bottom of board.
5. Disconnect all wires from board.
6. Lift board from unit.
7. To replace, reverse removal procedures.

5-6.5 Digital Module.

1. Remove bottom cover.
2. Using no. 1 Phillips screwdriver remove all screws from module cover.

NOTE

The optional Remote Control board is contained inside the Digital module, and is replaced as a separate subassembly.

3. Using no. 1 Phillips screwdriver remove 2 screws from remote control board inside module (if installed).
4. Lift remote control board with ribbon cable from module (if installed).
5. Disconnect keyboard ribbon cable.
6. Disconnect display ribbon cable.
7. Disconnect shaft encoder cable.
8. Replace cover on module.
9. Using a 7/64 inch Allen wrench, loosen 8 Allen screws from module.
10. Pull module from motherboard connector.
11. To replace, reverse removal procedures.

CAUTION

When reinstalling Digital module cover, ensure ribbon cable from Remote Control board is routed correctly. Ribbon cable may be damaged if pinched between cover and module housing or components.

5-6.6 Remote Control Board (optional).

1. Remove bottom cover.
2. Using no. 1 Phillips screwdriver remove all screws from Digital module cover.
3. Using no. 1 Phillips screwdriver remove 2 screws from remote control board inside Digital module.
4. Lift remote control board from module.
5. Remove ribbon cable from board.
6. To replace, reverse removal procedures.

5-6.7 Keypad Board.

1. Remove bottom cover.
2. Remove cable from Keypad board.
3. Using 3/16 inch wrench, remove 6 nuts and attaching hardware from board.
4. Lift board from unit.
5. Ensure rubber conductive keypad remains in place in front panel assembly.
6. To replace, reverse removal procedures.

5-6.8 Keypad.

1. Remove bottom cover.
2. Remove cable from Keypad board.
3. Using 3/16 inch wrench, remove 6 nuts and attaching hardware from board.
4. Lift board from unit.

5. Remove rubber conductive keypad from front panel assembly.
6. To replace, reverse removal procedures.

5-6.9 Display Module.

1. Remove top and bottom cover.
2. Remove top cover from Digital module.
3. Disconnect ribbon cables from Digital module board connecting to Keypad and Display module.
4. Replace Digital module cover.
5. Using no. 2 Phillips screwdriver, remove 4 screws on each side of chassis securing front panel to chassis.

CAUTION

In the next step be careful not to stress wires attached to front panel assembly components. Wires or connectors may break.

6. Carefully rotate top of front panel assembly away from chassis about 1 inch. Push front panel assembly down slightly, then rotate top of front panel assembly away from chassis to reach components on rear of front panel.
7. Using 1/4 inch nut driver, remove 3 nuts and attaching hardware securing module to front panel.
8. Lift module from unit.
9. To replace, reverse removal procedures.

5-6.10 Main Adjustment Knob.

1. Using 1/16 inch Allen wrench, loosen set-screws, and remove knob from shaft.
2. To replace, reverse removal procedures.

5-6.11 Optical Shaft Encoder.

1. Remove top cover.
2. Record wire color positions on connector, and remove connector from encoder.
3. Using no. 1/16 inch Allen wrench, loosen set-screws, and remove main adjustment knob from shaft.
4. Using 1/2 inch wrench, remove nut and attaching hardware securing shaft assembly to front panel.
5. Lift shaft encoder from unit.
6. To replace, reverse removal procedures.

5-6.12 Fan Assembly

1. Remove top and bottom covers.
2. Using no. 1 Phillips screwdriver and 3/16 inch wrench, remove 4 screws and attaching hardware from fan assembly.
3. Cut tie wrap as necessary and disconnect fan cable from connector.
4. Remove finger guard and attaching hardware from fan.
5. To replace, reverse removal procedures.

5-6.13 Support Handles

1. Remove top and bottom covers.

NOTE

To replace either front panel handle, remove front panel. To remove either rear panel handle, remove rear panel.

2. Using no. 2 Phillips screwdriver, remove screws on each side of chassis securing front and/or rear panel to each side of chassis.
3. Without disconnecting any cables, carefully pull front and/or rear panel assembly away from chassis.
4. Using no. 2 Phillips screwdriver, remove 2 screws securing handles to front and/or rear panel.
5. To replace, reverse removal procedures.

5-7 SOFTWARE UPLOADING.

The exciter's control and DSP software may be replaced using the remote control connector on the rear of the unit to gain access to the unit's flash memory. Depending on which remote control option is installed in the receiver, the upload may be done using a DOS-based personal computer with a serial bus null-modem cable and one of the COMM ports on the PC, or an IEEE-488 cable and special interface card installed in the PC.

To access the upload menu, press and hold one of the front panel keys while turning the unit on. Refer to the upload documentation supplied with the software for details.

CHAPTER 6 PREPARATION FOR RESHIPMENT

6-1 INTRODUCTION.

This chapter contains information to prepare the unit for reshipment including disassembly and removal from the rack mount, packaging, and shipping.

6-2 DISASSEMBLY AND REMOVAL.

To disassemble and remove the unit from the rack mount, perform the following procedures:

1. Ensure the power switch is set to OFF.
2. Disconnect the input power cable.
3. Disconnect all cables from the rear panel.
4. Remove the unit from the rack mount if used.

6-3 PACKAGING.

NOTE

The unit should be packed in the original shipping container if available.

To package the unit for reshipment perform the following steps:

1. Ensure that there is sufficient foam packing material in the shipping container to protect the

unit from any hard impact.

2. Cover the unit with foam or bubble-type packing material.
3. Place the unit in the center of the shipping container.
4. If using a cardboard packing carton, securely tape the seams of the carton's top cover, bottom cover, and side flaps with reinforced packing tape.
5. Attach labels or stamp in indelible ink the word FRAGILE on the top, bottom, and all sides of the container.

6-4 SHIPPING.

CAUTION

Unit contains parts and assemblies sensitive to damage by electrostatic discharge (ESD). Do not ship or store near strong electrostatic, electromagnetic, magnetic or radioactive fields.

There are no special shipping requirements for the unit. Commercial or military surface or air shipping services may be used.

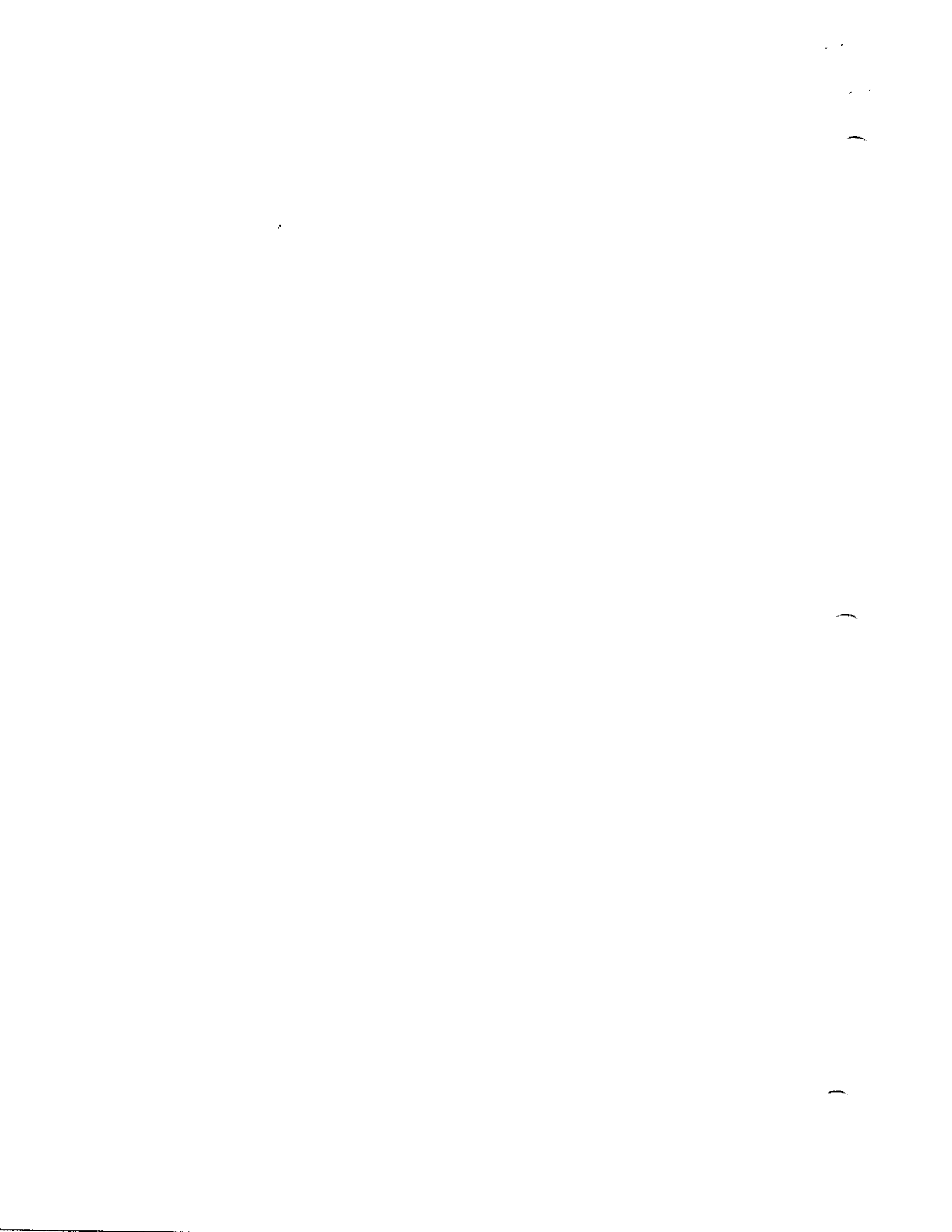

CHAPTER 7 STORAGE

7-1 INTRODUCTION.

This chapter contains information for storage of the equipment including environmental conditions and any special preservation requirements.

7-2 STORAGE ENVIRONMENT.

The exciter should be stored indoors in the original shipping container (or similar container) as described in chapter 6. The humidity should be between 40 and 90% (non-condensing) with a temperature range of -40 to +85°C.

CAUTION

Unit contains parts and assemblies sensitive to damage by electrostatic discharge (ESD). Do not ship or store near strong electrostatic, electromagnetic, magnetic or radioactive fields.

7-3 PRESERVATION.

There are no special coverings or preservation materials required to store the exciter.



CHAPTER 8 PARTS LIST

8-1 INTRODUCTION.

This chapter contains the parts list for replaceable modules and chassis-mounted components at the operational maintenance level.

8-2 REPLACEABLE PARTS LISTING.

Table 8-1 lists replaceable modules and chassis-mounted components for the unit. (See figure FO-5 for locations.)

Table 8-1 Replaceable Parts.

Qty	Description	Part Number	Remarks	Mfr
1	Board, Keypad	260235-1		CCI ¹
1	Board, AC Line Filter	260340-1		CCI
1	Board, Serial Remote	260245-1	(Optional) In Digital Module. Cable below required.	CCI
1	Board, IEEE-488 Remote	260250-1	(Optional) In Digital Module. Cable below required.	CCI
1	Cable Assy, Fan	260395-1	Includes fan	CCI
1	Cable Assy, IEEE-488 to rear panel	260279-1	(Optional) IEEE-488 board rqrd	CCI
1	Cable Assy, Serial to rear panel	260386-2	(Optional) Serial board rqrd	CCI
1	Finger Guard, Fan	115-027		CCI
4	Handle, Support	2600-4407-7		CCI
1	Keypad, Rubber Conductive	260006-1		CCI
1	Kit, Dual Rack-Mount	2600-1009-1	(Two T-4180 exciters required)	CCI
1	Knob Assy, 1/4 shaft	260264-1	Main Adjustment	CCI
1	Module, Digital	2607-1101-1		CCI
1	Module, Synthesizer	2607-1102-1		CCI
1	Module, RF Analog	2607-1103-1		CCI
1	Module, Power Supply	260259-1		CCI
1	Module, Display	260018-1		CCI
1	Optical Shaft Encoder Assy	174-005		CCI
1	Power cord, AC	696-012		CCI

¹Cubic Communications, Inc. (FSCM 59532)



ANNEX A

TECHNICAL MANUAL ANNEX

OPERATION AND MAINTENANCE INSTRUCTIONS

OPERATIONAL LEVEL

OPERATING BY EMISSION DESIGNATORS

NOTICE:

This annex is incomplete without the associated technical manual



Cubic Communications Inc.
9535 Waples Street
San Diego, California 92121-2953

Telephone: (619) 643-5800 Telefax: (619) 643-5803

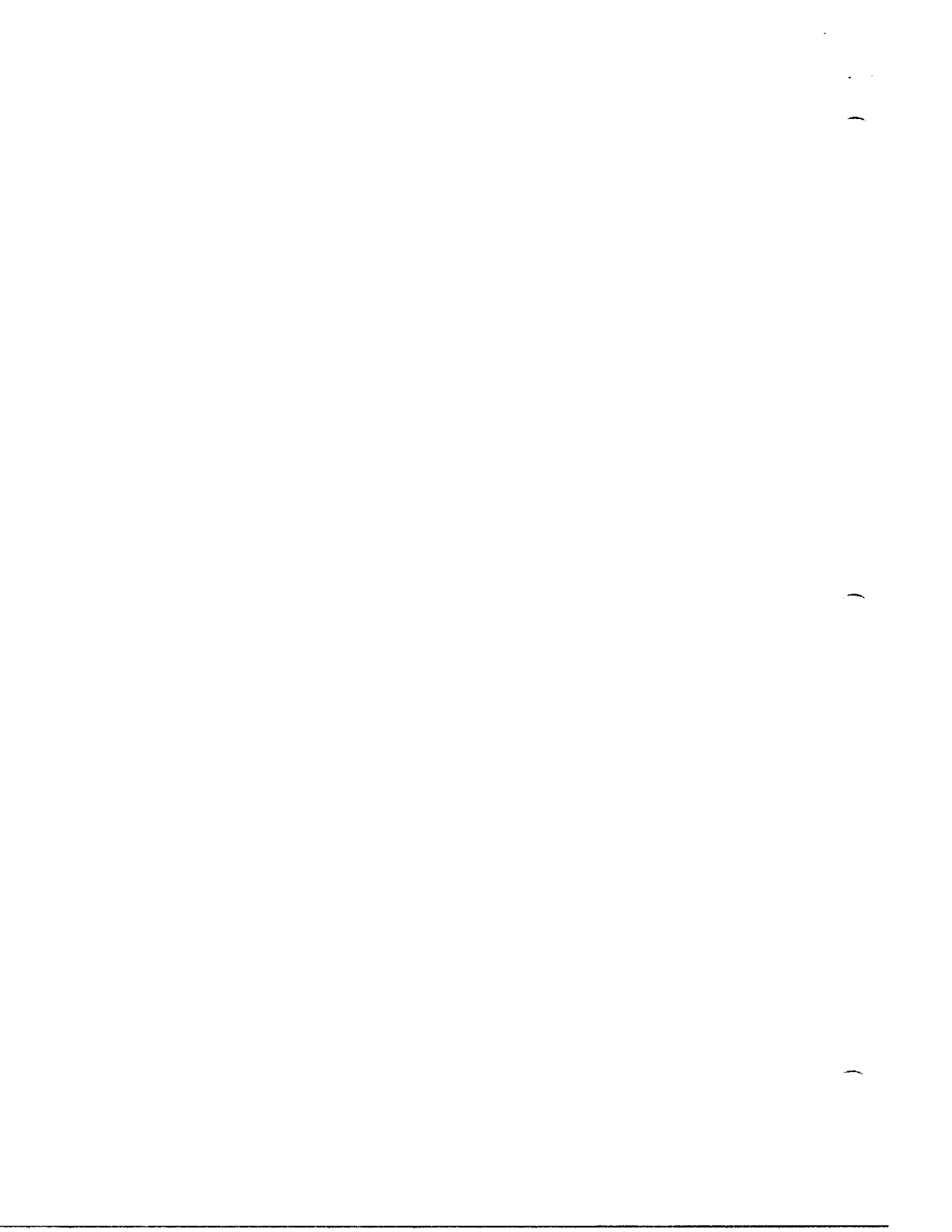

ANNEX TO T-4150/80

OPERATING BY EMISSION DESIGNATORS

The following table provides information to operate the T-4150/80 using selected FCC emission designators.

T-4150/80 Operation by FCC Emission Designator.

Emission Designator	Modulation Mode	Audio Source	Description
A1A/A1B	CW	----	This is unmodulated continuous wave (CW) using the KEY input (on/off key).
A2A/A2B	AM	TONE	This is amplitude modulation using the KEY input and the programmed internal TONE signal as a modulating Subcarrier (modulated CW). The user must select AM modulation mode, program the desired frequency of the internal generated sine wave, and select the audio SOURCE to be TONE. Note: When the KEY is open, the RF output signal consists of the carrier only up to ½ second, i.e., when going from a KEY closed condition to a KEY open condition, the carrier is left on for an additional ½ second. The carrier is ramped up on key close and ramped down on key open. When the KEY is closed, the modulation tone signal is ramped up, and is immediately ramped down when the KEY is opened.
A3E	AM	MIC/LINE	This is standard analog AM modulation either from the MIC or NORM LINE audio input.
B8E	ISB	LINE	This is analog ISB modulation using the both the NORM and ALT LINE audio inputs.
F1A/F1B	FSK	LINE	This is the FSK modulation mode. The input signal is sampled and filtered from the NORM LINE audio input channel. If the filtered signal is positive, a positive frequency shift equal to ½ the programmed shift value is done, while for a negative input, the frequency shift is ½ the shift value subtracted from the center carrier frequency.
F1C	FMfax	LINE	This is analog FM Fax modulation. The input signal is sampled and filtered from the NORM LINE audio input channel. This is the same as FM modulation, except any DC component in the input signal is not filtered out.
F3C	FM	MIC/LINE	This is standard analog FM modulation using the MIC or NORM LINE audio input
H2A/H2B	USBfc/LSBfc	TONE	This is USBfc or LSBfc (full carrier) modulation using the KEY input and the programmed internal TONE signal as a modulating Subcarrier. The user must select USBfc or LSBfc modulation mode, program the desired frequency of the internal generated sine wave, and select SOURCE to be TONE. Note: When the KEY is open, the output signal consists of the carrier only up to ½ second, i.e., when going from a KEY closed condition to a KEY open condition, the carrier is left on for an additional ½ second. The carrier is ramped up on key close, and ramped down on key open. When the KEY is closed, the modulation tone signal is ramped up, and is immediately ramped down when the KEY is opened.
H3E	USBfc/LSBfc	MIC/LINE	This is analog USBfc or LSBfc modulation using the MIC or LINE audio input. USBfc is commonly referred to as AME.
J2A/J2B	USB/LSB	TONE	This is USB or LSB modulation using the KEY input and the programmed internal TONE signal as a modulating Subcarrier. The user must select USB or LSB modulation mode, program the desired frequency of the internal generated sine wave, and select SOURCE to be TONE. Note: When the KEY is open, the output signal consists of the carrier only up to ½ second, i.e., when going from a KEY closed condition to a KEY open condition, the carrier is left on for an additional ½ second. The carrier is ramped up on key close, and ramped down on key open. When the KEY is closed, the modulation tone signal is ramped up, and is immediately ramped down when the KEY is opened.
J3E	USB/LSB	MIC/LINE	This is standard analog USB or LSB modulation using the MIC or LINE audio input.
R2A/R2B	USBpc/LSBpc	TONE	This is USBpc or LSBpc (partial carrier) modulation using the KEY input and the programmed internal TONE signal as a modulating Subcarrier. The user must select USBpc or LSBpc modulation mode, program the desired frequency of the internal generated sine wave, and select SOURCE to be TONE. Note: When the KEY is open, the output signal consists of the carrier only up to ½ second, i.e., when going from a KEY closed condition to a KEY open condition, the carrier is left on for an additional ½ second. The carrier is ramped up on key close, and ramped down on key open. When the KEY is closed, the modulation tone signal is ramped up, and is immediately ramped down when the KEY is opened.
R3C/R3E	USBpc/LSBpc	MIC/LINE	This is analog USBpc or LSBpc modulation using the MIC or LINE audio input.



ANNEX B

TECHNICAL MANUAL ANNEX

OPERATION AND MAINTENANCE INSTRUCTIONS

OPERATIONAL LEVEL

DC POWER SUPPLY OPTION FOR T-4150/80 EXCITER

NOTICE:

This annex is incomplete without the associated technical manual



Cubic Communications Inc.
9535 Waples Street
San Diego, California 92121-2953

Telephone: (619) 643-5800 Telefax: (619) 643-5803

Change 2

30 January 1998

DC POWER SUPPLY OPTION

DESCRIPTION

This annex supplements the T-4150/80 technical manual and contains difference data for certain T-4150/80 models containing a DC power supply.

DIFFERENCES

The major differences are as follows:

Item	AC Version	DC Version	Remarks
Power Requirements	90 - 260 VAC 47 - 440 Hz, 50 watts	20 - 32 VDC, 3A maximum	
Power Connector (rear panel)	Connector Type - IEC 320-C-13 (CCI P/N 343-002) mates with NEMA 5-15P (CCI P/N 696-012, Power Cord)	Connector Type - MS3452W16S-1P (CCI P/N 320-008) mates with MS3456W16S-1S (CCI P/N 320-009)	Refer to Pin Description table below
Line Filter	P/N 260340-1	P/N 2608-2015-1	
Power Supply Module	P/N 260259-1	P/N 118-083	

DC POWER Connector (J1) Pin Descriptions.

Pin	Signal	Remarks
A	NC	
B	POWER RETURN (GND)	
C	NC	
D	POWER RETURN (GND)	
E	+VDC IN	+20 to +32 VDC, 3A maximum
F	+VDC IN	+20 to +32 VDC, 3A maximum
G	SHIELD GROUND	

For input power, the exciter functions identically to the AC powered T-4150/80 unit.

NOTES: UNLESS OTHERWISE SPECIFIED

- 1. ~~XX~~ INDICATES NUMBER OF CONDUCTORS IN CABLE.
- 2. ~~---~~ INDICATES RIBBON CABLE.
- 3. TWO REMOTE CONTROL ASSEMBLIES AVAILABLE:
 REMOTE CONTROL B.D. CABLE ASSY
 IEE-48B 268239-1
 SERIAL 268279-1
 268245-1
 268396-2
- 4. DIGITAL MODULES: DASH NUMBER INDICATES INSTALLED SOFTWARE.

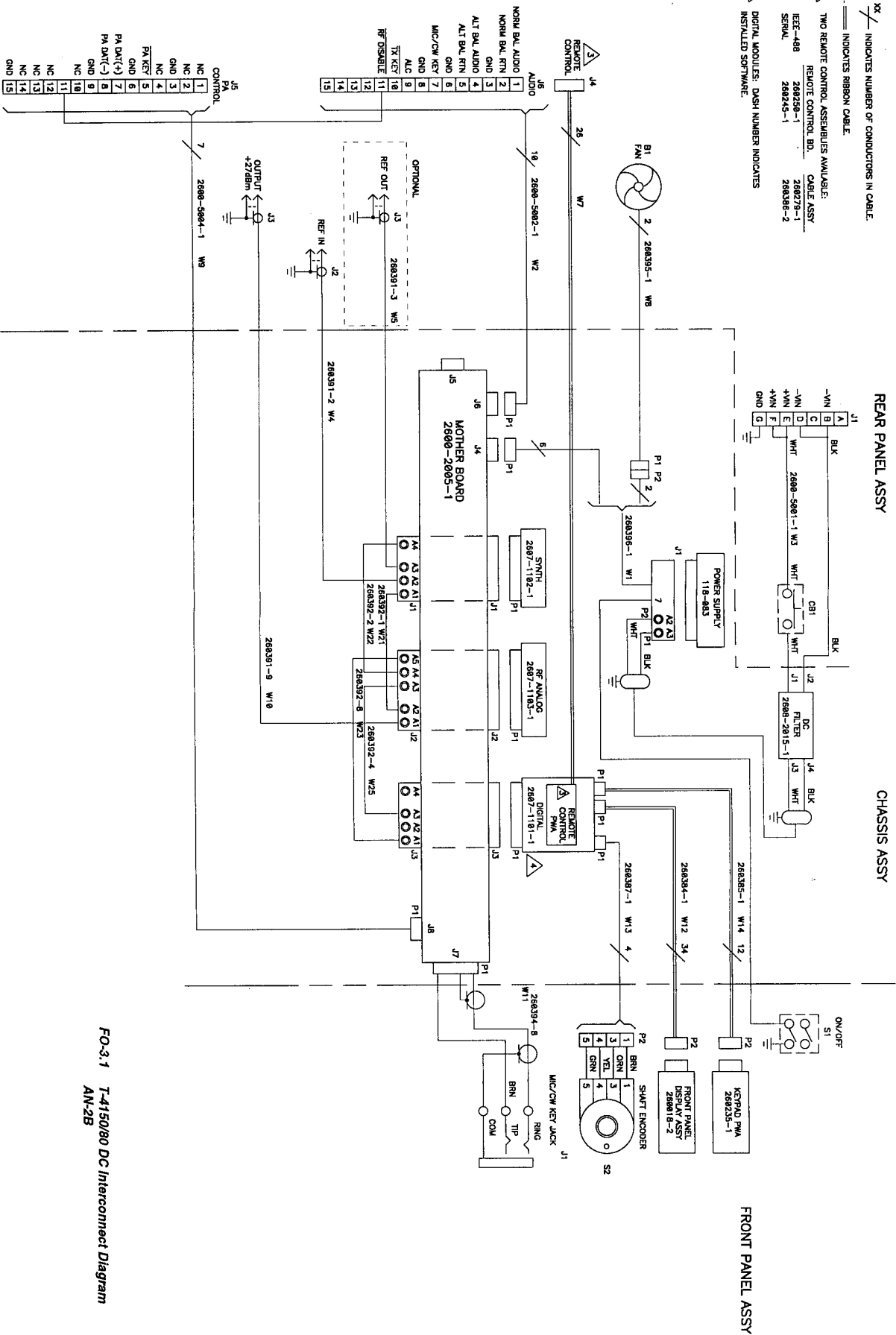

FO-3.1 T-4150/80 DC Interconnect Diagram AN-2B

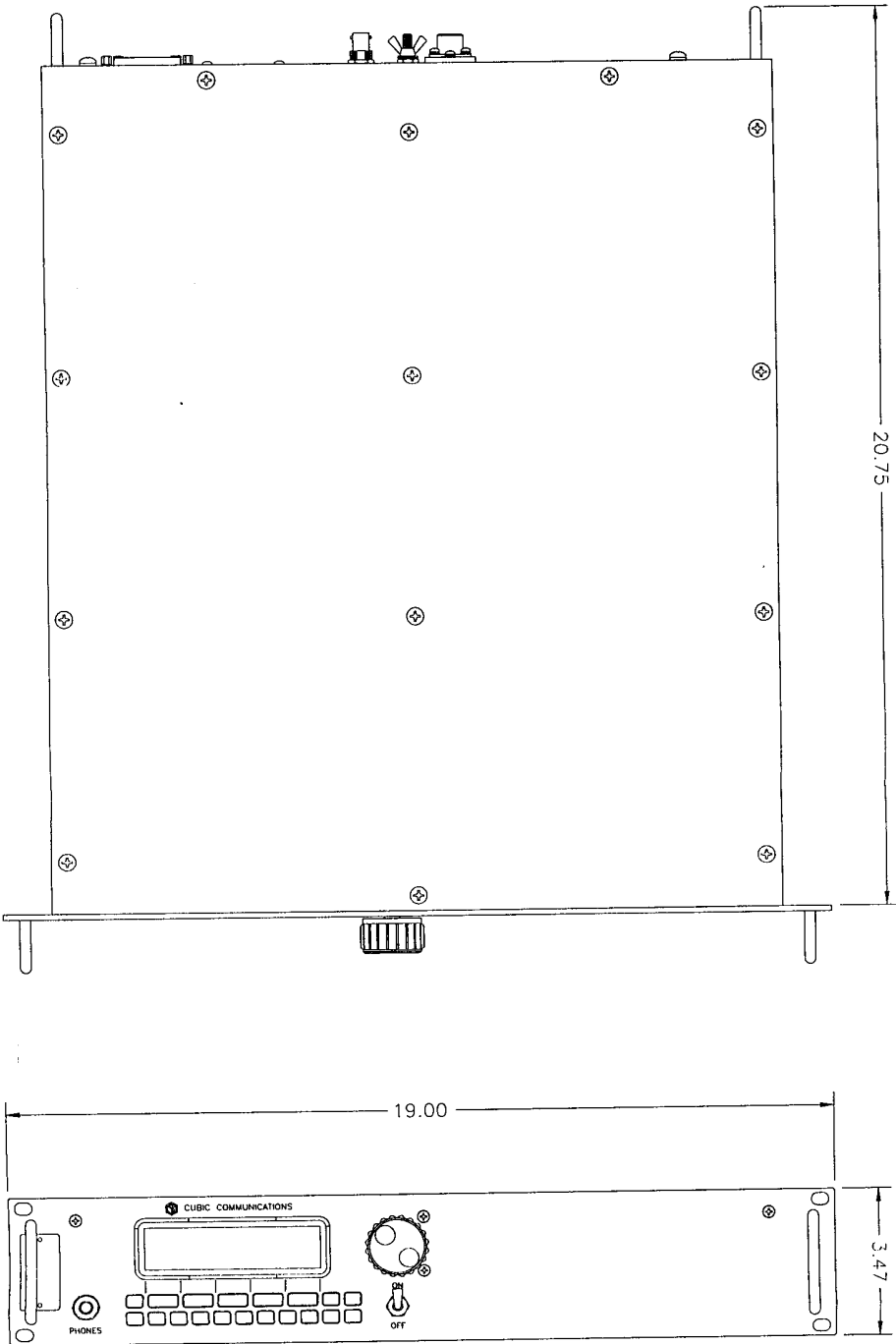

FO-1A, T-4150 Outline and Mounting Drawing
(Sheet 1 of 2)

FP-1/(FP-2 blank)

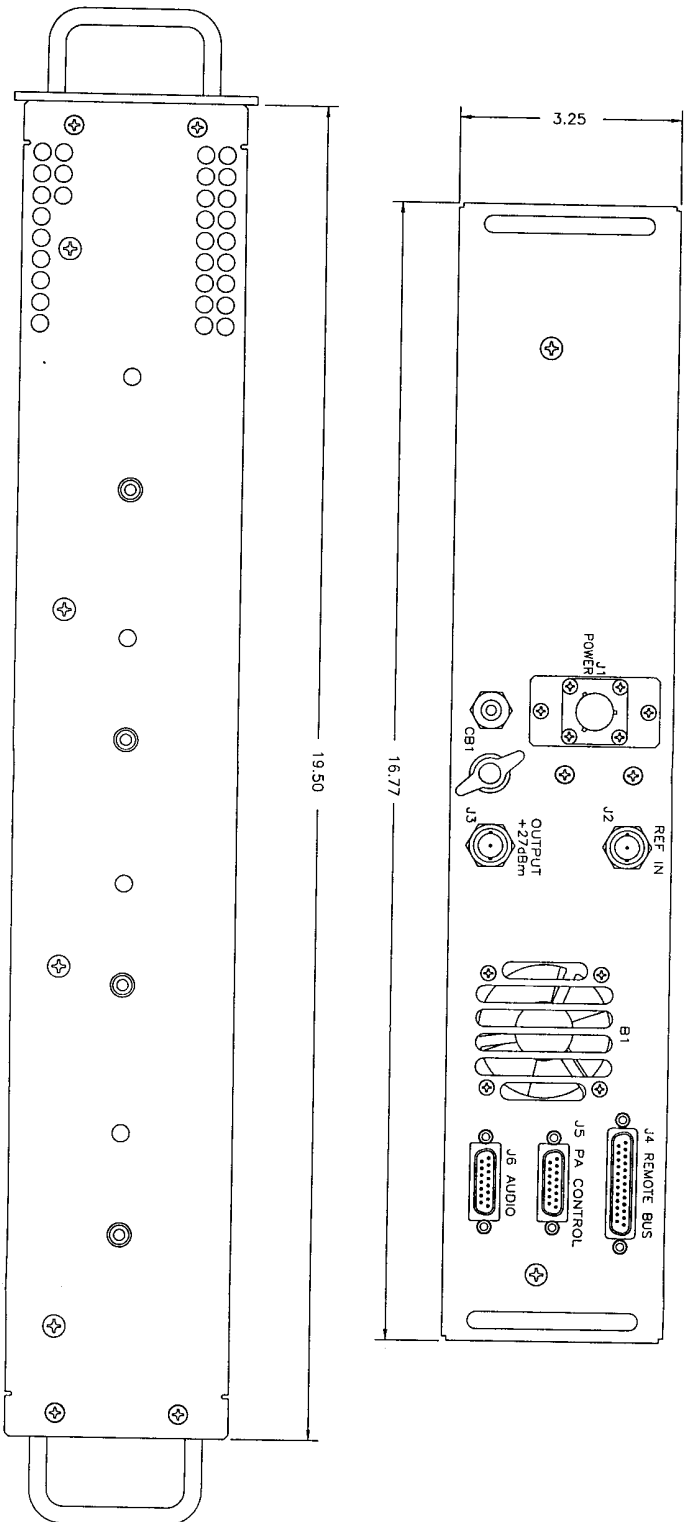

Rev B

FO-1A, T-4150 Outline and Mounting Drawing
 (Sheet 2 of 2)

FP-3(FP-4 blank)

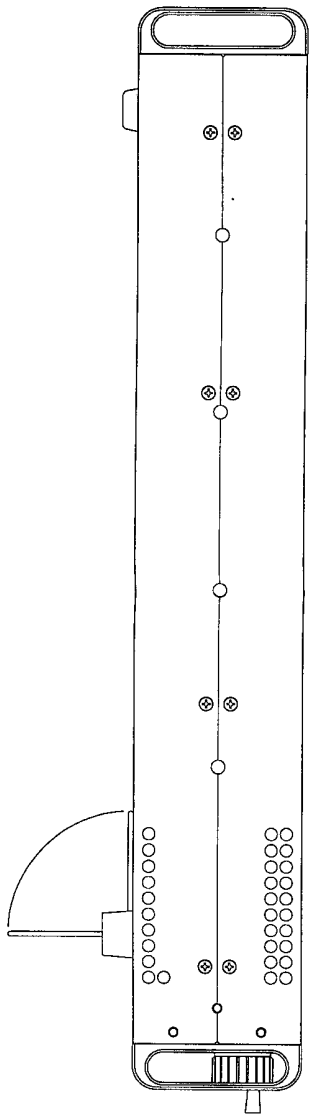
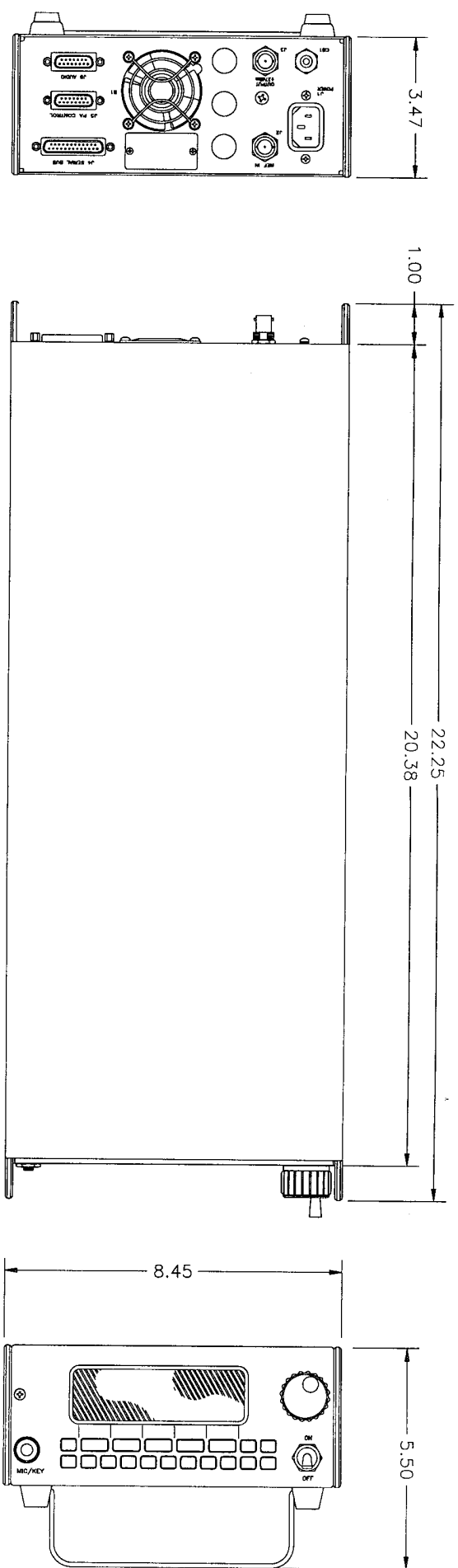

2607-1003
 Rev B

FO-1B, T-4180 Outline and Mounting Drawing.
 FP-5/(FP-6 blank)

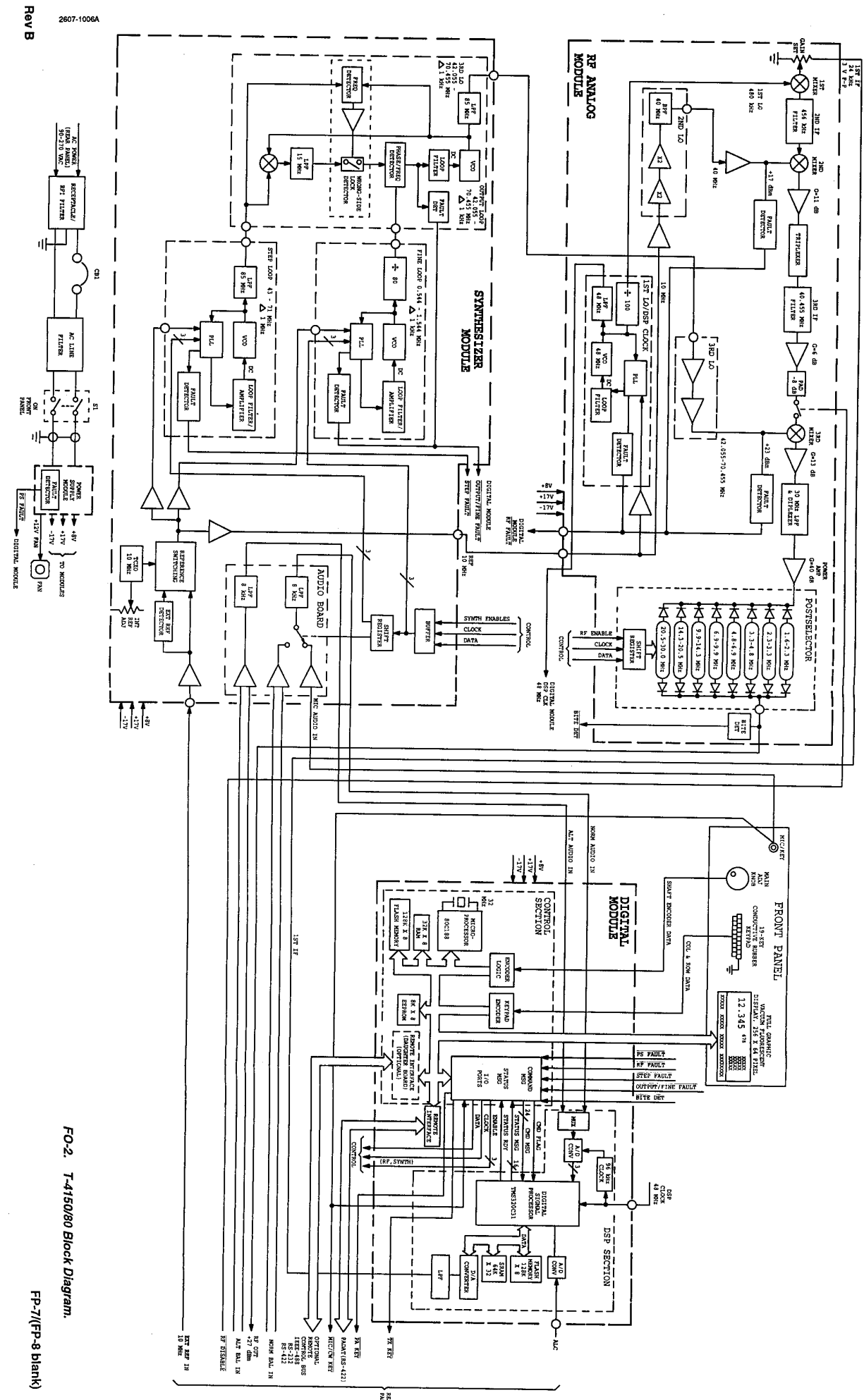

FO-2. T-4150/80 Block Diagram.

FP-7/(FP-8 blank)

Rev B

2807-1006A

NOTES : UNLESS OTHERWISE SPECIFIED

- 1. XX/ INDICATES NUMBER OF CONDUCTORS IN CABLE.
- 2. == INDICATES RIBBON CABLE.
- 3. TWO REMOTE CONTROL ASSEMBLIES AVAILABLE:
 REMOTE CONTROL ED. CABLE ASSY
 IEEE-488 260250-1
 SERIAL 260245-1
 260386-2
- 4. DIGITAL MODULES: DASH NUMBER INDICATES INSTALLED SOFTWARE.
- 5. PIN "D" IS ONLY ON T-4150 MODEL.

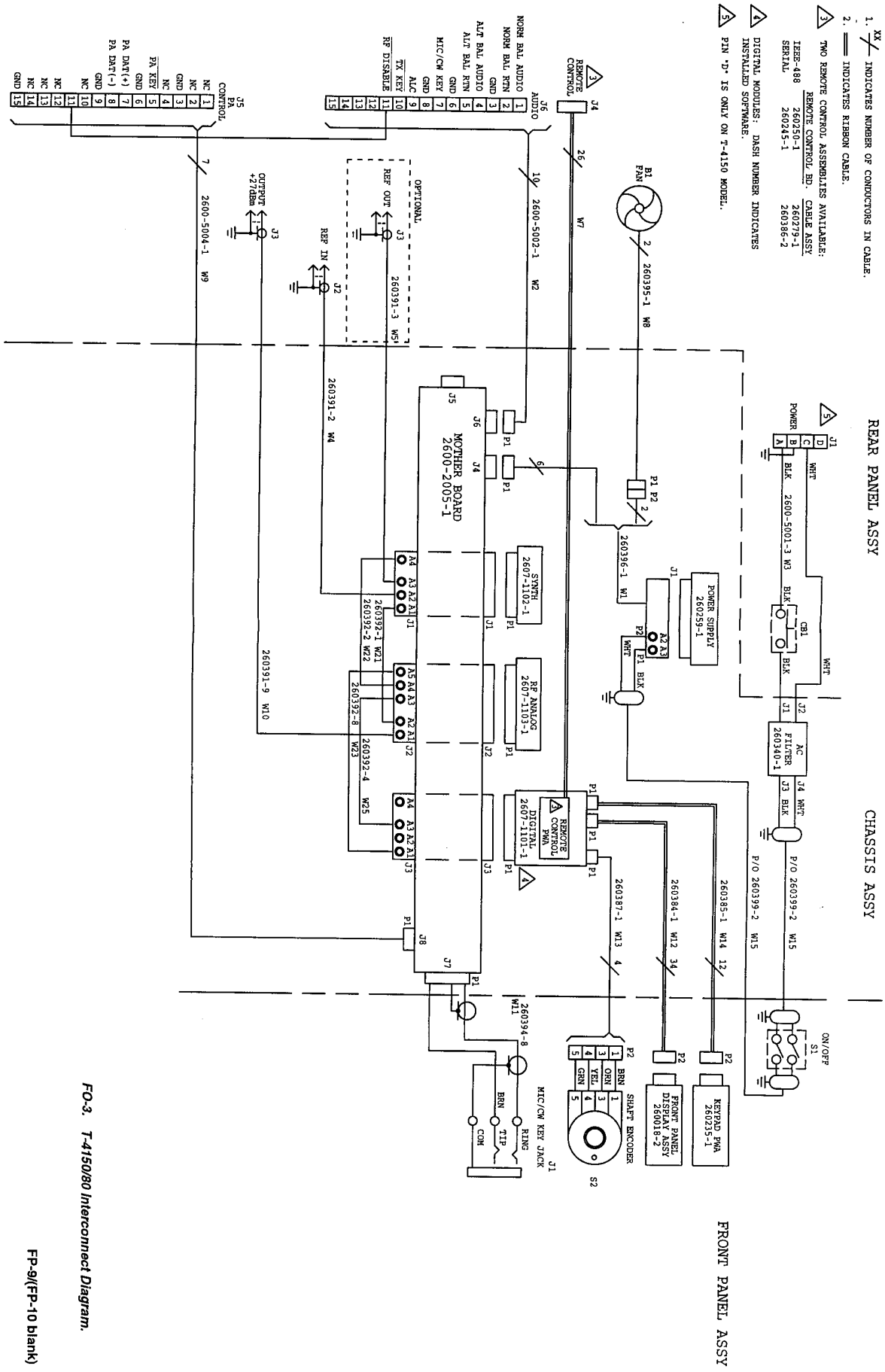

FO-3. T-4150/80 Interconnect Diagram.

FP-9/(FP-10 blank)

1. INTERPRET DRAWING IN ACCORDANCE WITH GOS-STD-100.
 2. CABLE CHANGES NOT SHOWN FOR CLARITY. REFER TO CHANGES FOR CLARITY.

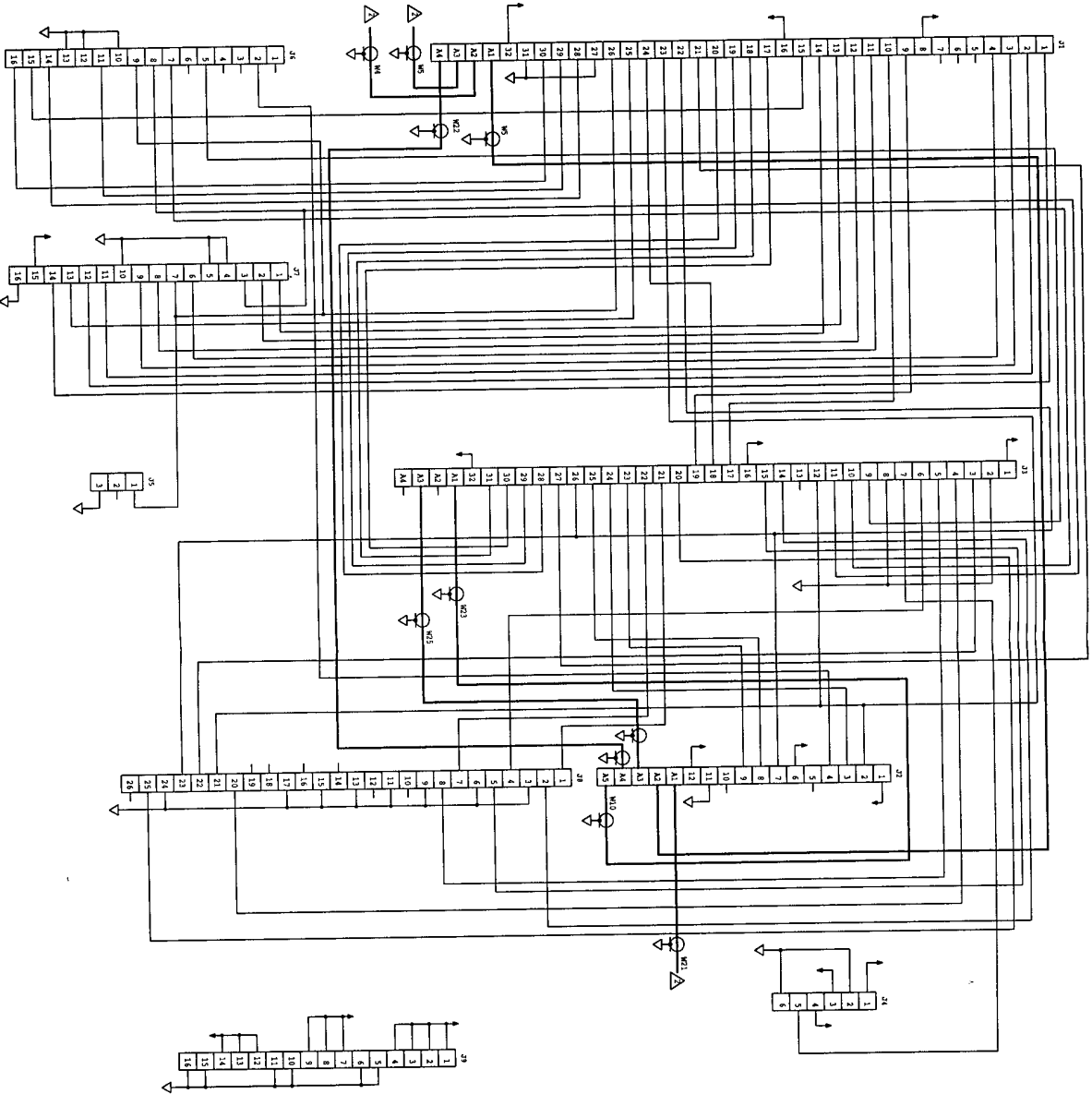

FO-4. T-4150/80 Motherboard Schematic
 (Sheet 1 of 2).
 FP-11/(FP-12 blank)

21	
SYMBOLOGY	MODULE
1	17 VOLTS
2	17 VOLTS
3	17 VOLTS
4	17 VOLTS
5	17 VOLTS
6	17 VOLTS
7	17 VOLTS
8	17 VOLTS
9	17 VOLTS
10	17 VOLTS
11	17 VOLTS
12	17 VOLTS
13	17 VOLTS
14	17 VOLTS
15	17 VOLTS
16	17 VOLTS
17	17 VOLTS
18	17 VOLTS
19	17 VOLTS
20	17 VOLTS
21	17 VOLTS
22	17 VOLTS
23	17 VOLTS
24	17 VOLTS
25	17 VOLTS
26	17 VOLTS
27	17 VOLTS
28	17 VOLTS
29	17 VOLTS
30	17 VOLTS
31	17 VOLTS
32	17 VOLTS
33	17 VOLTS
34	17 VOLTS

22	
SYMBOLOGY	MODULE
1	17 VOLTS
2	17 VOLTS
3	17 VOLTS
4	17 VOLTS
5	17 VOLTS
6	17 VOLTS
7	17 VOLTS
8	17 VOLTS
9	17 VOLTS
10	17 VOLTS
11	17 VOLTS
12	17 VOLTS
13	17 VOLTS
14	17 VOLTS
15	17 VOLTS
16	17 VOLTS
17	17 VOLTS
18	17 VOLTS
19	17 VOLTS
20	17 VOLTS
21	17 VOLTS
22	17 VOLTS
23	17 VOLTS
24	17 VOLTS
25	17 VOLTS
26	17 VOLTS
27	17 VOLTS
28	17 VOLTS
29	17 VOLTS
30	17 VOLTS
31	17 VOLTS
32	17 VOLTS
33	17 VOLTS
34	17 VOLTS

23	
SYMBOLOGY	MODULE
1	17 VOLTS
2	17 VOLTS
3	17 VOLTS
4	17 VOLTS
5	17 VOLTS
6	17 VOLTS
7	17 VOLTS
8	17 VOLTS
9	17 VOLTS
10	17 VOLTS
11	17 VOLTS
12	17 VOLTS
13	17 VOLTS
14	17 VOLTS
15	17 VOLTS
16	17 VOLTS
17	17 VOLTS
18	17 VOLTS
19	17 VOLTS
20	17 VOLTS
21	17 VOLTS
22	17 VOLTS
23	17 VOLTS
24	17 VOLTS
25	17 VOLTS
26	17 VOLTS
27	17 VOLTS
28	17 VOLTS
29	17 VOLTS
30	17 VOLTS
31	17 VOLTS
32	17 VOLTS
33	17 VOLTS
34	17 VOLTS

24	
SYMBOLOGY	MODULE
1	17 VOLTS
2	17 VOLTS
3	17 VOLTS
4	17 VOLTS
5	17 VOLTS
6	17 VOLTS

25	
SYMBOLOGY	MODULE
1	17 VOLTS
2	17 VOLTS
3	17 VOLTS

27	
SYMBOLOGY	MODULE
1	17 VOLTS
2	17 VOLTS
3	17 VOLTS
4	17 VOLTS
5	17 VOLTS
6	17 VOLTS
7	17 VOLTS
8	17 VOLTS
9	17 VOLTS
10	17 VOLTS
11	17 VOLTS
12	17 VOLTS
13	17 VOLTS
14	17 VOLTS
15	17 VOLTS
16	17 VOLTS

26	
SYMBOLOGY	MODULE
1	17 VOLTS
2	17 VOLTS
3	17 VOLTS
4	17 VOLTS
5	17 VOLTS
6	17 VOLTS
7	17 VOLTS
8	17 VOLTS
9	17 VOLTS
10	17 VOLTS
11	17 VOLTS
12	17 VOLTS
13	17 VOLTS
14	17 VOLTS
15	17 VOLTS

28	
SYMBOLOGY	MODULE
1	17 VOLTS
2	17 VOLTS
3	17 VOLTS
4	17 VOLTS
5	17 VOLTS
6	17 VOLTS
7	17 VOLTS
8	17 VOLTS
9	17 VOLTS
10	17 VOLTS
11	17 VOLTS
12	17 VOLTS
13	17 VOLTS
14	17 VOLTS
15	17 VOLTS
16	17 VOLTS
17	17 VOLTS
18	17 VOLTS
19	17 VOLTS
20	17 VOLTS
21	17 VOLTS
22	17 VOLTS
23	17 VOLTS
24	17 VOLTS
25	17 VOLTS
26	17 VOLTS
27	17 VOLTS
28	17 VOLTS

29	
SYMBOLOGY	MODULE
1	17 VOLTS
2	17 VOLTS
3	17 VOLTS
4	17 VOLTS
5	17 VOLTS
6	17 VOLTS
7	17 VOLTS
8	17 VOLTS
9	17 VOLTS
10	17 VOLTS
11	17 VOLTS
12	17 VOLTS
13	17 VOLTS
14	17 VOLTS
15	17 VOLTS
16	17 VOLTS
17	17 VOLTS
18	17 VOLTS
19	17 VOLTS
20	17 VOLTS
21	17 VOLTS
22	17 VOLTS
23	17 VOLTS
24	17 VOLTS
25	17 VOLTS
26	17 VOLTS
27	17 VOLTS
28	17 VOLTS
29	17 VOLTS

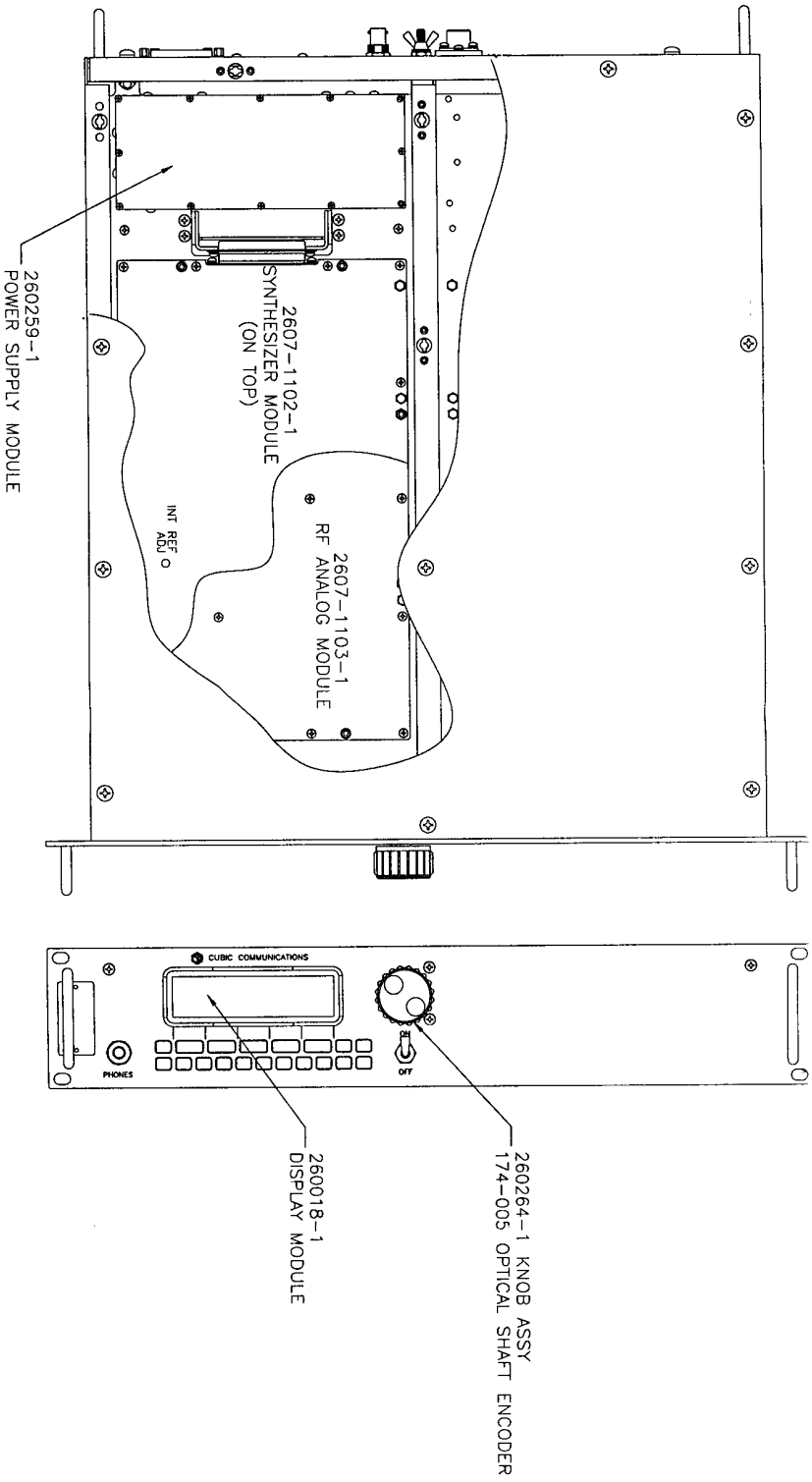

AVAILABLE BUT NOT SHOWN:
 696-012 AC POWER CORD

Rev B

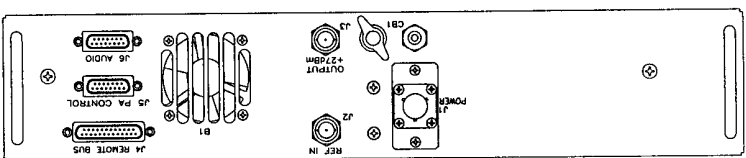
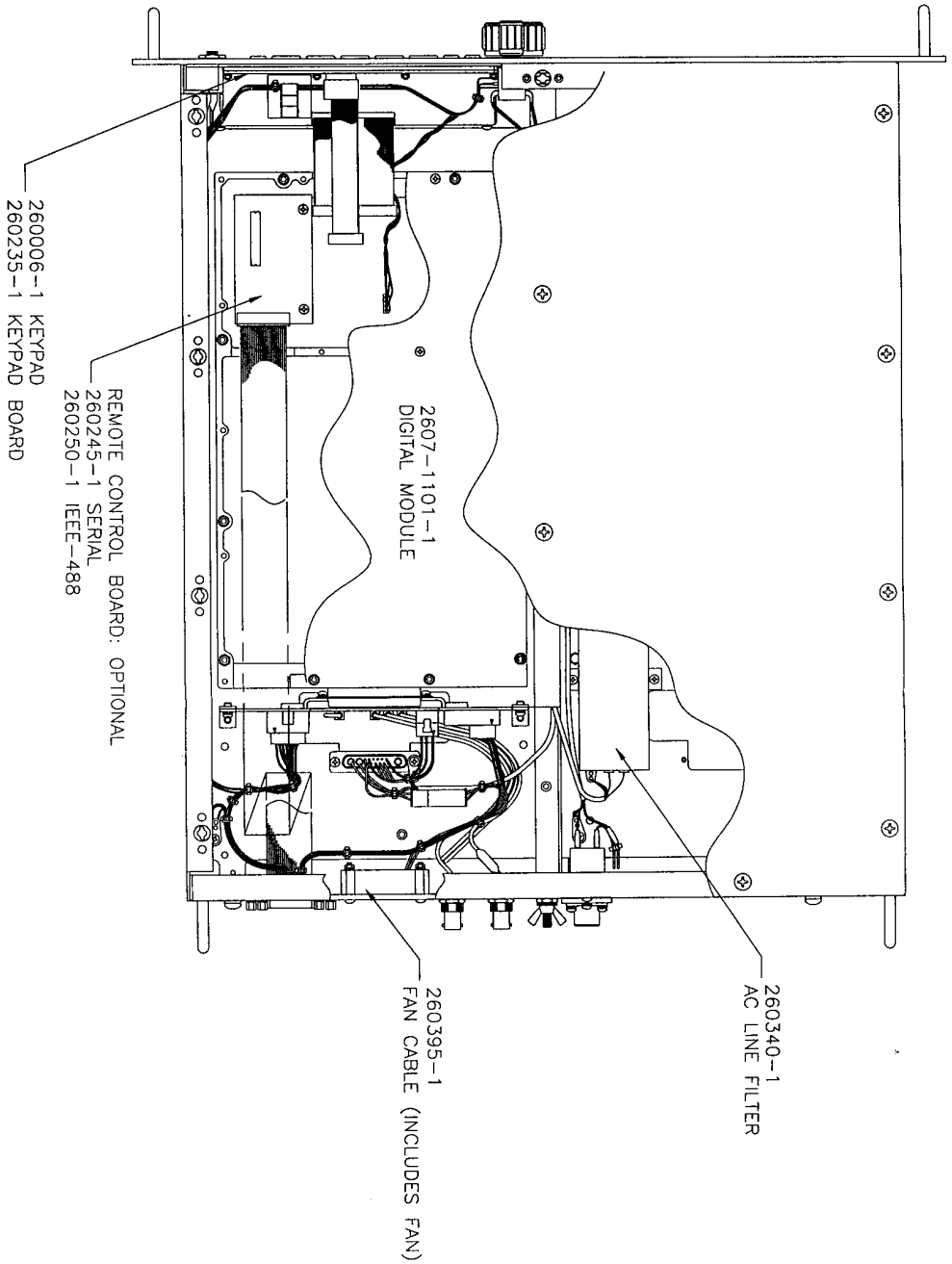

FO-5A, T-4150 Replaceable Parts Locator Diagram
 (Sheet 2 of 2)

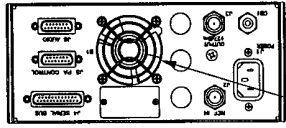

115-027
FINGER GUARD

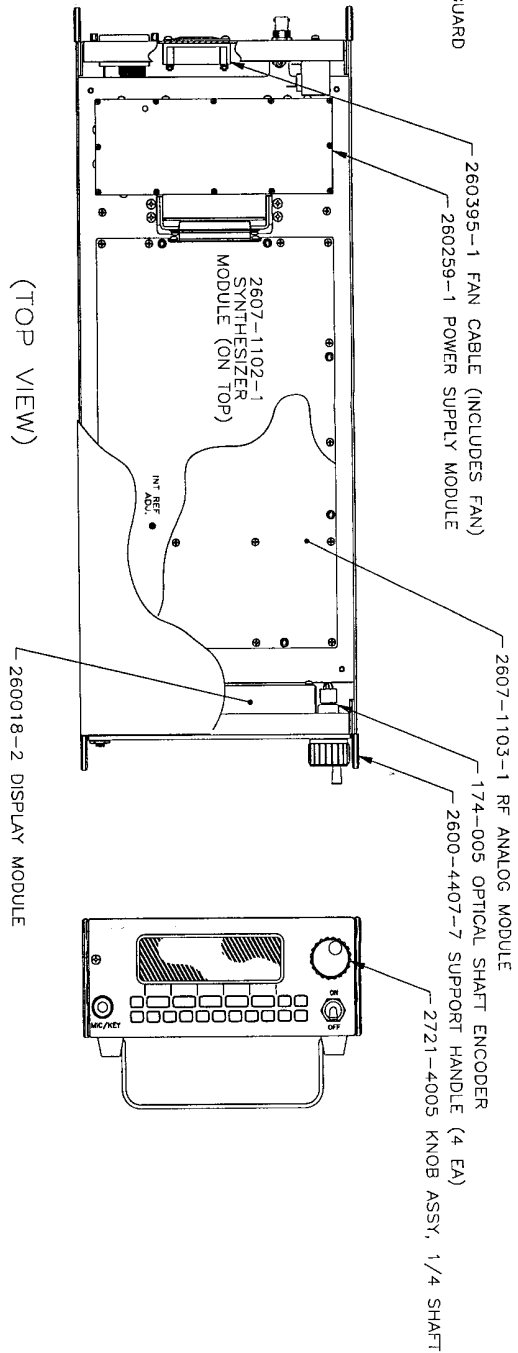

(TOP VIEW)

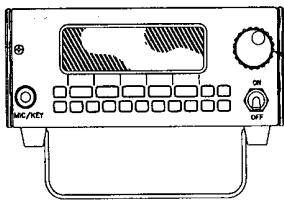

2721-4005 KNOB ASSY, 1/4 SHAFT

- 260340-1 AC FILTER BOARD
- REMOTE CONTROL BOARD: OPTIONAL
 - 260245-1 SERIAL
 - 260250-1 IEEE-488
- 260006-1 KEYPAD BOARD
- 260235-1 KEYPAD BOARD
- 2607-1101-1 DIGITAL MODULE
- AVAILABLE BUT NOT SHOWN:
 - 696-012 A.C. POWER CORD
 - 2600-1009-1 DUAL RACK MOUNT KIT

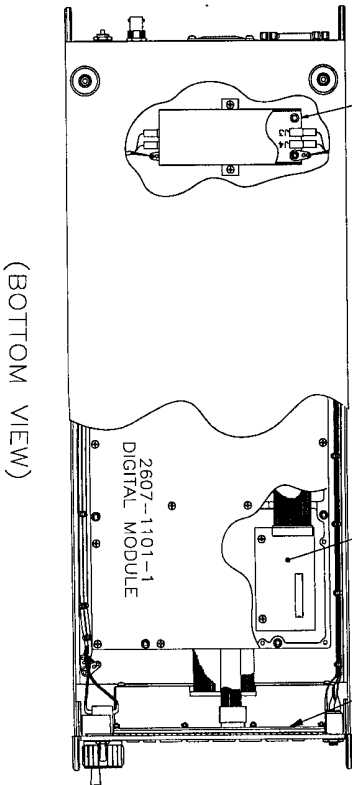

(BOTTOM VIEW)

FO-5B T-4180 Replaceable Parts Locator
 Diagram.

FP-19/(FP-20 blank)