

Attachment C3: CTX-1000 System

TECHNICAL MANUAL

OPERATION AND MAINTENANCE INSTRUCTIONS

OPERATIONAL LEVEL

POWER SUPPLY, 28V DC

PS-7130A-1

(160 - 264V AC SINGLE-PHASE INPUT)

(FCC VERSION)



Cubic Communications, Inc.
9535 Waples Street
San Diego, California 92121-2953

Telephone: (619) 643-5800 Telefax: (619) 643-5803

Manual Part No. 2242-1021-3

15 April 1998

FOREWORD

SCOPE

This manual contains information for the installer and operator to obtain best performance from the PS-7130A-1. The information includes: a general description, preparation for use and installation instructions, operating instructions, general theory of operation, maintenance instructions, preparation for reshipment, and parts list.

Component level maintenance is not included in this manual. Component level maintenance should be performed in the designated maintenance depot or the factory.

WARNING

Do not apply power to the equipment until the installation procedures in Chapter 2 have been successfully completed.

PROPRIETARY DATA

The information in this manual is the property of Cubic Communications Incorporated. Disclosure to a third party, either wholly or in part, without written consent from Cubic Communications Incorporated is prohibited.

CORRECTION NOTICE

The information in this manual is believed correct at publication date. If a difference is noted between the information in this manual and the equipment, contact the factory for clarification. Current and future editions will be corrected as necessary.

RIGHTS RESERVED

Cubic Communications Incorporated reserves the right to change the specifications, design, and fabrication methods of equipment at any time without notice.

FCC CERTIFICATION

The PS-7130A-1 when used with the PA-5050A and the T-4150/80-9 comprises the CTX-1000 System. This system is FCC certified for aeronautical base station usage. The FCC identification number is NVSCTX-1000.

TABLE OF CONTENTS

<u>Chapter</u>		<u>Page</u>
1	GENERAL DESCRIPTION	1-1
1-1	INTRODUCTION	1-1
1-2	EQUIPMENT DESCRIPTION	1-1
1-3	EQUIPMENT SUPPLIED AND REQUIRED	1-1
1-4	STORAGE DATA	1-1
1-5	TOOLS AND TEST EQUIPMENT	1-1
1-6	SAFETY PRECAUTIONS	1-1
2	PREPARATION FOR USE AND INSTALLATION INSTRUCTIONS	2-1
2-1	INTRODUCTION	2-1
2-2	UNPACKING AND INSPECTION	2-1
2-3	INSTALLATION	2-2
2-4	CONNECTIONS	2-2
3	OPERATING INSTRUCTIONS	3-1
3-1	INTRODUCTION	3-1
3-2	OPERATION	3-1
3-3	EMERGENCY OPERATION	3-1
4	GENERAL THEORY OF OPERATION	4-1
4-1	INTRODUCTION	4-1
4-2	OVERALL THEORY	4-1
5	MAINTENANCE INSTRUCTIONS	5-1
	Section I. PREVENTIVE MAINTENANCE	5-1
5-1	INTRODUCTION	5-1
5-2	CLEANING AND LUBRICATION	5-1
5-3	INSPECTION	5-1
5-4	PERFORMANCE VERIFICATION	5-1
	Section II. CORRECTIVE MAINTENANCE	5-2
5-5	TROUBLESHOOTING	5-2
	5-5.1 <u>Troubleshooting Philosophy</u>	5-2
	5-5.2 <u>Troubleshooting Procedure</u>	5-2
	5-5.2.1 <u>Fault Identification</u>	5-2
	5-5.2.2 <u>Initial Checks</u>	5-2
	5-5.2.3 <u>Status LED Interpretation</u>	5-2
	5-5.2.3.1 <u>One PS Status LED Off</u>	5-3
	5-5.2.3.2 <u>Multiple PS Status LEDs Off</u>	5-3
	5-5.2.3.3 <u>No PS Status LEDs Off</u>	5-3
	5-5.2.4 <u>Module Replacement</u>	5-3
	5-5.2.4.1 <u>Removal</u>	5-3
	5-5.2.4.2 <u>Replacement</u>	5-3
	5-5.2.5 <u>Voltage/Continuity Checks</u>	5-3
6	PREPARATION FOR RESHIPMENT	6-1
6-1	INTRODUCTION	6-1
6-2	DISASSEMBLY AND REMOVAL	6-1
6-3	PACKAGING	6-1
6-4	SHIPPING	6-1
7	STORAGE	7-1
7-1	INTRODUCTION	7-1
7-2	STORAGE ENVIRONMENT	7-1
7-3	PRESERVATION	7-1
8	PARTS LIST	8-1
8-1	INTRODUCTION	8-1
8-2	REPLACEABLE PARTS LISTING	8-1

LIST OF ILLUSTRATIONS

<u>Figure</u>		<u>Page</u>
1-1	PS-7130A-1 Front View	1-2
2-1	PS-7130A-1 Rear Panel	2-3
3-1	PS-7130A-1 Controls and Indicators	3-2
4-1	PS-7130A-1 Block Diagram	4-2
FO-1	PS-7130A-1 Outline and Mounting Drawing	FP-1
FO-2	PS-7130A-1 Interconnect Diagram	FP-3
FO-3	PS-7130A-1 Interconnect Diagram	FP-5
FO-4	PS-7130A-1 Parts Locator Diagram	FP-7

LIST OF TABLES

<u>Table</u>		<u>Page</u>
1-1	PS-7130A-1 Specifications	1-3
1-2	Items Furnished and Required	1-3
1-3	Recommended Tools and Test Equipment (Or Equivalent)	1-3
2-1	Rear Panel Connections	2-2
2-2	DC POWER Connector (J1) Pin Descriptions	2-4
2-3	AC POWER Connector (J2) Pin Descriptions	2-4
2-4	SIGNAL (J3) Pin Descriptions	2-5
3-1	Front Panel Controls and Indicators	3-1
8-1	Replaceable Parts List	8-1
8-2	Optional Parts List	8-1

CHAPTER 1 GENERAL DESCRIPTION

1-1 INTRODUCTION. This chapter contains a description of the equipment supplied, equipment required but not supplied, storage data, and recommended tools and test equipment.

1-2 EQUIPMENT DESCRIPTION. The PS-7130A-1 power supply (figure 1-1) supplies four independent regulated +28V DC voltages at 30 amperes and one +28V DC voltage at 11 amperes using 160 to 264 volts, 50/60 Hz, single phase AC input power. The PS-7130A-1 is normally used to supply power to the CCI PA-5050A power amplifier.

The front panel contains a PWR LED indicating when input power is on and a switch/circuit breaker to apply input power and protect the equipment. Four independent modular power supplies provide the five +28V DC outputs. The four power supply modules are identical and interchangeable. The front panel contains individual PS lamps indicating the +28V DC output is present. The rear panel contains connectors for power/signal outputs, AC power input, and chassis grounding. Two internal cooling fans provide ambient air flow through the unit. Refer to FO-1 for a detailed physical description.

1-3 EQUIPMENT SUPPLIED AND REQUIRED. Table 1-2 lists the items furnished, items required but not supplied, and optional items.

1-4 STORAGE DATA. Refer to Chapter 7 for storage data.

1-5 TOOLS AND TEST EQUIPMENT. Table 1-3 lists recommended tools and test equipment for organizational level maintenance. There are no special tools or test equipment required.

1-6 SAFETY PRECAUTIONS. Safety precautions are presented in this manual preceded by the word WARNING or CAUTION just before the point where the hazard is likely to be encountered. Warnings and cautions are defined as follows:

WARNING

Refers to a procedure or practice that, if not correctly followed, could result in injury, death, or long term health hazard.

CAUTION

Refers to a procedure or practice that, if not correctly followed, could result in damage to, or destruction of equipment.

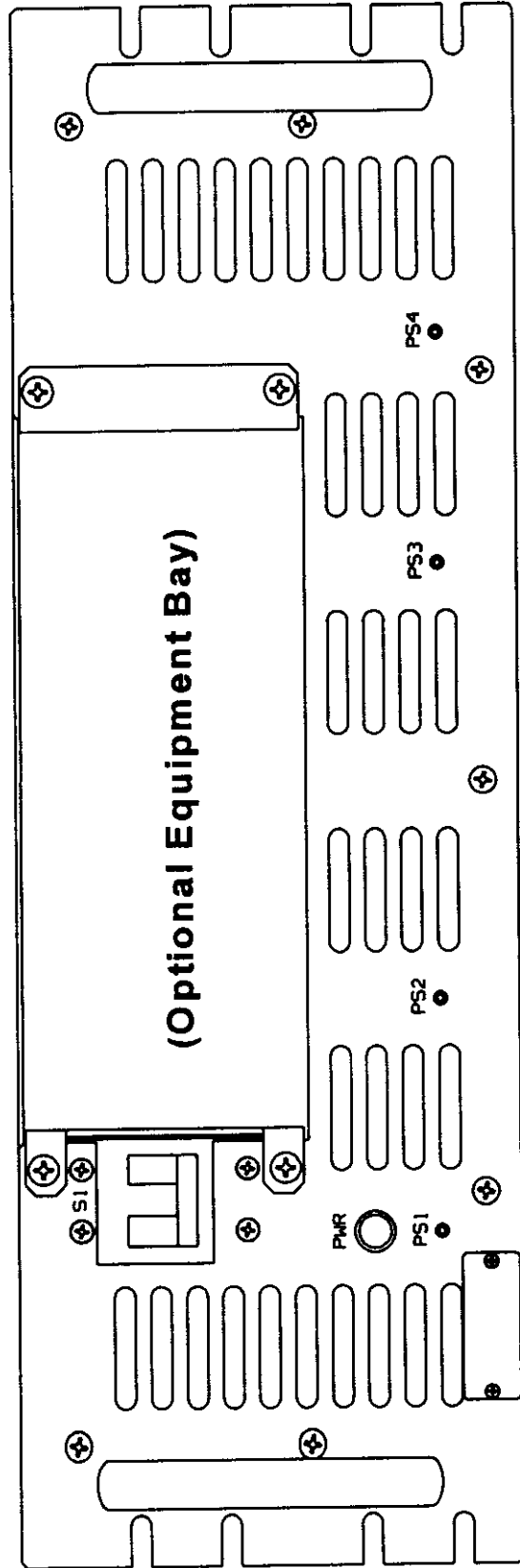

Figure 1-1 PS-7130A-1 Front View.

Table 1-1 PS-7130A Specifications.

Item	Specification	
ELECTRICAL REQUIREMENTS		
Input Voltage	160 - 264V AC (RMS) (220V AC typical)	
Frequency Range	50/60 Hz	
Input Current	30 Amperes maximum	
Power Consumption	3,400 Watts maximum	
Output Voltage	+28VDC nominal (5 ea.)	
Output Current	30 amperes max. (each of 4 outputs), 11 amperes max. (1 output)	
ENVIRONMENTAL		
Ambient Temperature	0 to +50°C operating, -40 to +75°C storage	
Humidity	95% non-condensing	
CONNECTORS	<u>On Chassis</u>	<u>Mates With</u> (CCI Part No.s)
DC Power (J1)	2241-4304-2	2241-4304-3
AC PWR (J2)	343-006	320-129
SIGNALS (J3)	25 pin D Sub (F) 324-021	25 pin Sub (M) 344-349
PHYSICAL		
Size	6 ½ in. high x 19 in. wide x 21.2 in. deep (front panel to rear handles)	
Weight	Approx. 33 pounds	

Table 1-2 Items Furnished and Required.

Part No.	Qty.	Nomenclature	Furn./Reqd.
2242-1000-1	01	PS-7130A Power Supply	Furnished
2242-1021-3	01	Technical Manual, Operation and Maintenance Instructions, POWER SUPPLY, PS-7130A	Furnished
2241-5028-1	01	Signal Cable	Optional, furnished with FCC system
2241-5031-1	01	DC Cable	Optional, furnished with FCC system

Table 1-3 Recommended Tools and Test Equipment (Or Equivalent).

Part No.	Nomenclature	Manufacturer
-	No. 1 Phillips screwdriver, 6 in.	Standard
-	No. 2 Phillips screwdriver, 6 in.	Standard
8050A	Digital Multimeter	Fluke

CHAPTER 2

PREPARATION FOR USE AND INSTALLATION INSTRUCTIONS

2-1 INTRODUCTION. This chapter contains unpacking, inspection, installation, connections, and initial alignment procedures for the power supply.

2-2 UNPACKING AND INSPECTION. To unpack and inspect the power supply for damage, perform the following procedures:

1. Inspect the shipping carton for damage before unpacking the power supply.

NOTE

If the carton is damaged, open the carton in the presence of a shipping carrier agent if possible. If damage is found after the power supply is unpacked, retain the carton and packing materials for inspection.

2. Open the carton and remove the foam packing material on top of the power supply.



Do not support the weight of the unit by the front panel alone. The chassis may bend or warp. Use chassis slides or a suitable support shelf.

3. Lift the power supply from the carton.

NOTE

The carton should be saved for possible reshipment.

4. Inspect the power supply for external damage including dents and scratches. Do not attempt to operate the power supply if damage is found.

2-3 INSTALLATION. The power supply is designed for rack slide mounting in a relatively dust free environment with an ambient temperature range between 0 and +50°C.

CAUTION

Ensure slide mounting screws are of the proper length. If screws are too long internal equipment may be damaged.

NOTE

See figure FO-1 for clearance requirements and mounting details.

1. Securely mount the outer section of the slides to the rack cabinet being sure to select the correct mounting holes.
2. Attach indicated right and left slide rails to each side of unit.
3. Before tightening the mounting screws, slide the chassis assembly into the rack mounted portion of the slides and adjust the hardware position as required for a smooth sliding fit.
4. Remove unit from rack and securely tighten all hardware.

2-4 CONNECTIONS. Refer to table 2-1 and connect the ground lug, power/signals, AC power and auxiliary power cables to the unit. (See figure 2-1.)

NOTE

Refer to the PA-5050A Technical Manual if the PA-5050A power amplifier is used.

WARNING

Severe injury or **DEATH** can result if bodily contact is made with an ungrounded chassis should high leakage current or a short-circuit condition occur.

Table 2-1 Rear Panel Connections.

Name	Type	Mating Type	Description
PWR (J1)	320-106	320-107	+28V DC output voltages (refer to Table 2.2).
AC PWR (J2)	343-006	320-129	AC power source input. Table 2-3 lists the signals on each pin of the connector.
SIG (J3)	324-021	344-349	Control and confidence signals to/from the linear amplifier (CCI PA-5050A). Table 2-4 lists the signals on each pin of the connector.
GND	Stud/Wing nut	---	This connection is required for ground loop interference reduction, leakage current and/or short circuit-current paths. Use 3/4-inch wide braided lead and connect to unpainted, clean, bare metal on platform ground.
NOTE: Part numbers in parenthesis (000-000) indicate CCI part number if applicable.			

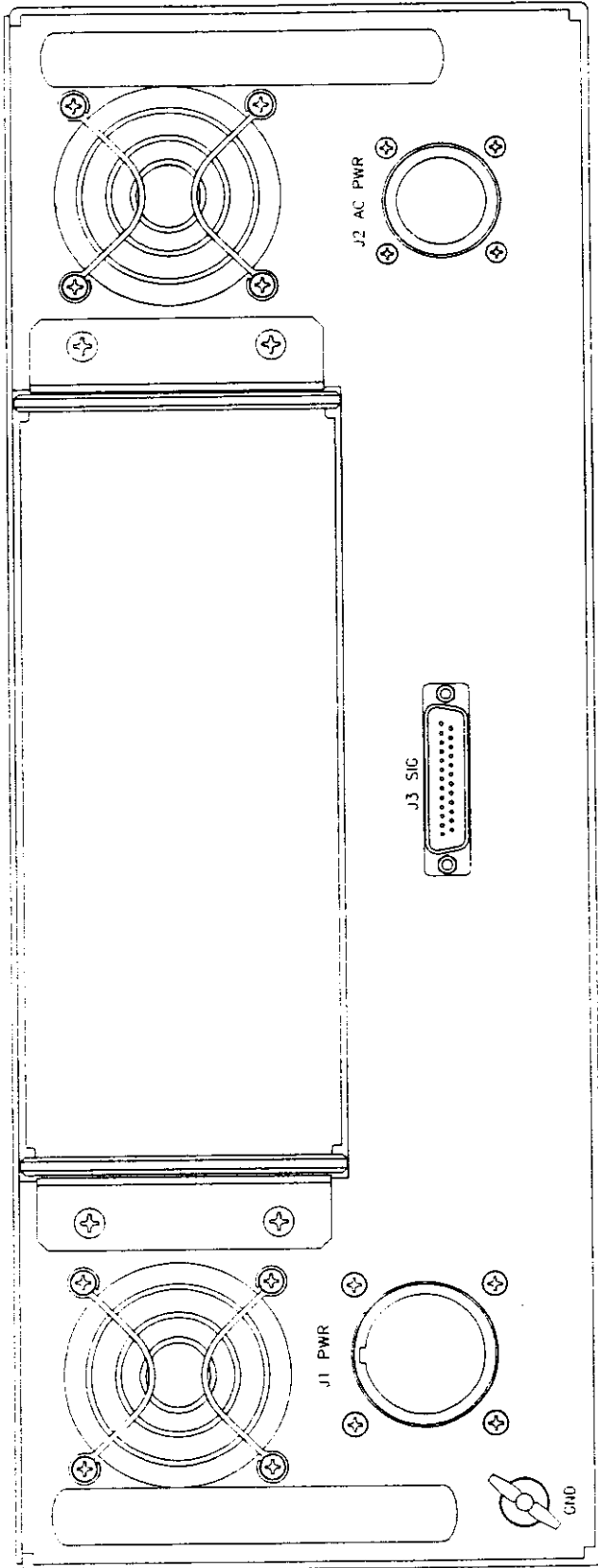

Figure 2-1 PS-7130A-1 Rear Panel

Table 2-2 DC POWER Connector (J1) Pin Descriptions.

Pin	Signal	Remarks
A	+28V	PS1 Output, 30 Amps
N	GND	PS1 Output
J	+28V	PS2 Output, 30 Amps
T	GND	PS2 Output
S	+28V	PS3 Output, 30 Amps
E	GND	PS3 Output
R	+28V	PS4 Output, 30 Amps
P	GND	PS4 Output
U	+28V	AUX Output, 11 Amps
V	GND	AUX Output

Table 2-3 AC POWER Connector (J2) Pin Descriptions.

Pin	Signal	Remarks
A	AC	160 - 264V AC, 50/60 Hz Input
B	GND	Ground
C	N/C	Not connected
D	AC	160 - 264V AC, 50/60 Hz Input

Table 2-4 SIGNAL (J3) Pin Descriptions.

Pin	Signal	Remarks
1	#1 LED+, 28V	#1 Power Supply J2 pin 4
2	#1 LED-, GND	#1 Power Supply J2 pin 5
3	#2 LED+, 28V	#2 Power Supply J2 pin 4
4	#2 LED-, GND	#2 Power Supply J2 pin 5
5	#3 LED+, 28V	#3 Power Supply J2 pin 4
6	#3 LED-, GND	#3 Power Supply J2 pin 5
7	#4 LED+, 28V	#4 Power Supply J2 pin 4
8	#4 LED-, GND	#4 Power Supply J2 pin 5
9	#1 Sense+	Power Supply J3 pin 1
10	#1 Sense-	Power Supply J3 pin 2
11	#2 Sense+	Power Supply J3 pin 1
12	#2 Sense-	Power Supply J3 pin 2
13	#3 Sense+	Power Supply J3 pin 1
14	#3 Sense-	Power Supply J3 pin 2
15	#4 Sense+	Power Supply J3 pin 1
16	#4 Sense-	Power Supply J3 pin 2
17	(Opt) #5 Sense+	Power Supply J3 pin 1
18	(Opt) #5 Sense-	Power Supply J3 pin 2
19	(Opt) #5 LED+, 28V	Power Supply J2 pin 4
20	(Opt) #5 LED-, GND	Power Supply J2 pin 5
21-25	NC	

CHAPTER 3 OPERATING INSTRUCTIONS

3-1 INTRODUCTION. This chapter contains PS-7130A-1 power supply operating instructions.

3-2 OPERATION. Operation is performed using the front panel controls and indicators. (See figure 3-1.) Table 3-1 lists the front panel controls and indicators and their functions.

To turn on, and initially set-up the PS-7130A-1, perform the following procedures:

1. Set the front panel switch/circuit breaker on (up). The front panel PWR LED will light.
2. Observe the PS1 - PS4 LEDs for all four power supply modules light.
3. To shut down the PS-7130A-1, turn the front panel switch/circuit breaker off (down).

Table 3-1 Front Panel Controls and Indicators.

Control	Function
Power Switch/Circuit Breaker (S1)	Applies/removes input power to the PS-7130A-1. Also protects PS-7130A-1 circuits from internal over current conditions.
PWR LED	Indicates the PS-7130A-1 is on.
PS1 - PS4 LEDs	Indicates the individual power supply +28V DC outputs are good.

3-3 EMERGENCY OPERATION. There are no emergency operating procedures for the unit. Power is removed from the unit by turning off the power on the front panel switch/circuit breaker and/or removing the power source from the rear panel.

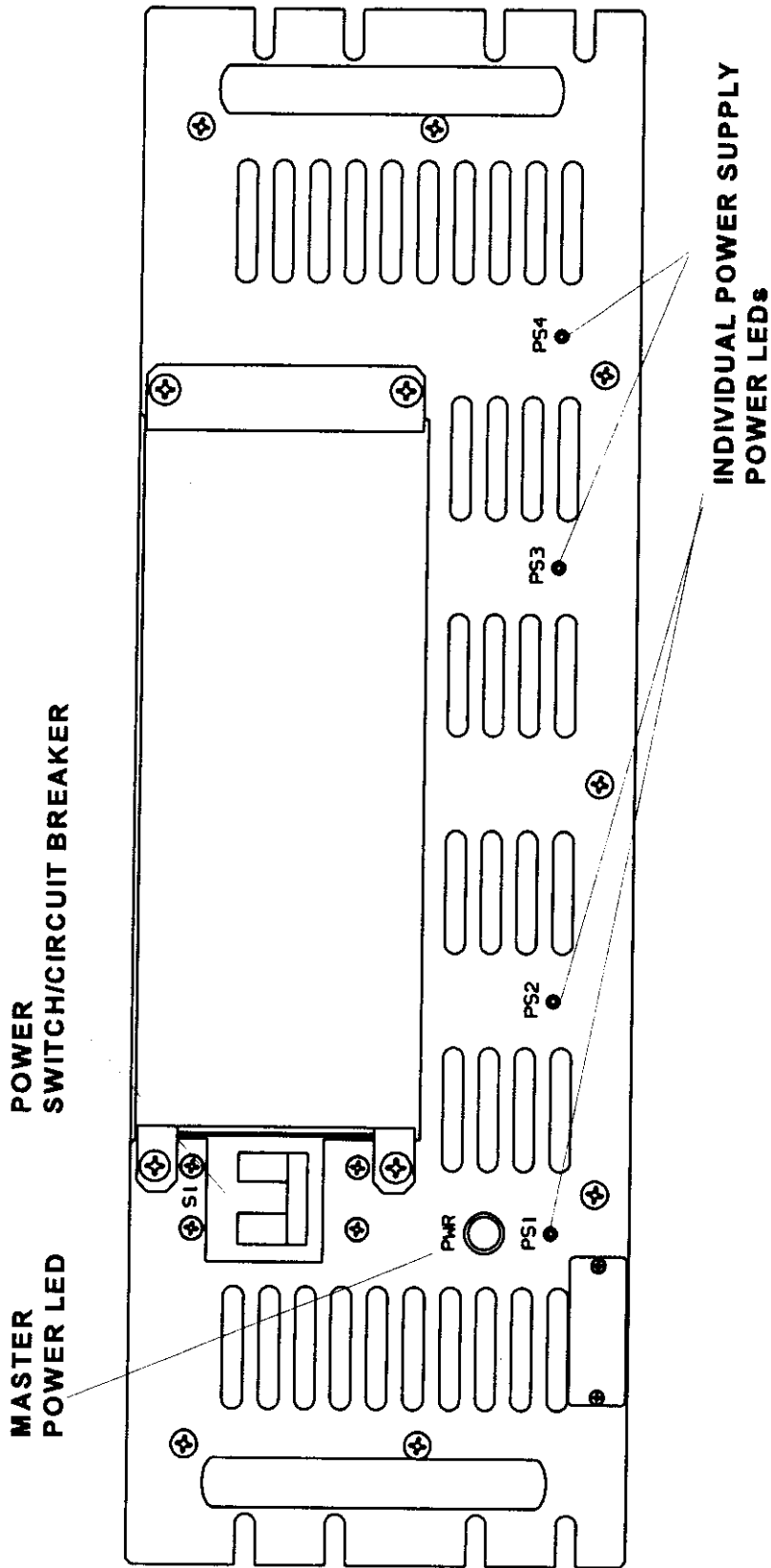

Figure 3-1 PS-7130A-1 Controls and Indicators.

CHAPTER 4 GENERAL THEORY OF OPERATION

4-1 INTRODUCTION. This chapter describes the PS-7130A-1 theory of operation (see figure F0-2).

4-2 OVERALL THEORY. When the front panel power switch/circuit breaker (S1) is set on, AC power is applied from the rear panel connector (J2) to the four power supply modules through an AC line filter. The AC line filter keeps internally generated power supply switching noise off the AC input line.

Four identical and interchangeable Power Supply modules provide four +28VDC outputs up to 30 amperes each to rear panel connector (J1). The four power supply outputs are also applied to a diode rectifier pair that provides an additional +28VDC output to the rear panel at 11 amperes. Sensors in the external equipment (PA-5050A) provide four inputs (V1± (SENSE) which causes each power supply module to maintain the correct voltage output.

Each power supply provides a signal to the PS1 - PS4 LEDs on the front panel when the respective power supply module is on.

CHAPTER 5 MAINTENANCE INSTRUCTIONS

Section I. PREVENTIVE MAINTENANCE

5-1 INTRODUCTION. This chapter contains both preventive and corrective operational level maintenance instructions. The information includes cleaning and lubrication, inspection, performance verification, troubleshooting, and module replacement.

5-2 CLEANING AND LUBRICATION. Clean the external surfaces and front panel of the PS-7130A-1 every 2 weeks using a vacuum cleaner or small soft brush to remove any dirt or dust.

5-3 INSPECTION. Perform a visual inspection of the unit quarterly by checking the unit and connecting cables for physical damage.

5-4 PERFORMANCE VERIFICATION. Performance of the PS-7130A-1 is verified by correct operation of the unit using the output voltages and the presence of PS1 - PS4 LEDs being lit. If the output voltages of the PS-7130A-1 are suspect, measure the voltages using a voltmeter.

Section II. CORRECTIVE MAINTENANCE

5-5 TROUBLESHOOTING.

5-5.1 Troubleshooting Philosophy. Certain assumptions are made concerning the troubleshooting approach as applied to the unit as follows:

1. All point-to-point wiring is correct. Therefore, no malfunction is the result of a wiring (or cable connector) fault.

NOTE

Suspected failure of cables or connectors require visual inspection and continuity tests using the appropriate diagram. See FO-3 for interconnecting diagram.

2. Malfunctions are non-interactive. Each symptom of a problem is caused by a single malfunction and no additional failures occurred during the troubleshooting process.
3. Multiple faults can be isolated if they are non-interactive.
4. Preventive maintenance has been performed (Section I).

5-5.2 Troubleshooting Procedure. Refer to chapter 4 for the block diagram description. Equipment troubleshooting should be performed in the following order:

1. Fault identification.
2. Initial checks.
3. Status LED interpretation.
4. Voltage/continuity checks.
5. Module replacement.

Refer to the following paragraphs for details:

5-5.2.1 Fault Identification. A fault is usually indicated by the PWR LEDs (PS1 - PS4) not lighting for one or more of the Power Supply modules, or the main switch/circuit breaker on the front panel tripping and unable to be reset.

5-5.2.2 Initial Checks. Before detailed troubleshooting, check that the PWR lamp on the front panel is on, and the circuit breaker is in the on (up) position. If the front panel PWR lamp is off, and the circuit breaker is on, ensure that input power is correct. Check the PS1 - PS4 LEDs for each Power Supply module. If one or more of the LEDs are off, remove and replace the Power Supply module(s) from the chassis (para 5-5.4). Check the connector(s) in the chassis for correct input voltage.

WARNING

When modules have been removed from the chassis and the power switch/circuit breaker (S1) is set on, high voltage may be present at the module connectors in the chassis. Use caution when working in these areas.

5-5.2.3 Status LED Interpretation. Each of the Power Supply modules contains a PS status LED (PS1 - PS4).

1. If only one PS status LED is off, refer to paragraph 5-5.2.3.1.
2. If more than one PS status LED is off, refer to paragraph 5-5.2.3.2
3. If no PS status LEDs are off, refer to paragraph 5-5.2.3.3

5-5.2.3.1 One PS Status LED Off. If a PS status lamp remains off after power-up, the fault is usually in the indicated Power Supply module. Remove and replace the Power Supply module with one from another slot to confirm the faulty module.

5-5.2.3.2 Multiple PS Status LEDs Off. If all or multiple PS status LEDs are off, check for low line input voltage.

5-5.2.3.3 No PS Status LEDs Off. If no PS status LEDs are off, the fault is probably in the chassis.

5-5.2.4 Module Replacement

CAUTION

Remove power before removing or replacing modules. Equipment may be damaged if modules are removed or replaced with power applied.

To remove and replace a Power Supply module, perform the following procedures:

5-5.2.4.1 Removal

1. Turn front panel Power Switch/Circuit Breaker off, and disconnect input power from Power Supply unit.
2. Remove top cover of the Power Supply unit. Remove the top and side screws holding the modules in place.
3. Disconnect the AC Input connector, control connector and unscrew the DC output cables.
4. Slide the module out of the chassis.

5-5.2.4.2 Replacement

1. Orient the module to align correctly.
2. Connect the AC Input connector, control connector and screw on the DC output cables.
5. Screw on the top and side securing screws for the module. Replace the top cover of the power supply unit.
6. Reconnect input power, and turn front panel Power Switch/Circuit Breaker on.

5-5.2.5 Voltage/Continuity Checks. If the failed module cannot be isolated using the above procedures, isolate the failed component by checking voltages and continuity of wires in the chassis.

WARNING

When the top cover is removed, high voltage may be present at the rear panel AC power connector, the AC line filter, and the front panel circuit breaker connections. Use caution when working in these areas.

1. Using a no. 2 Phillips screwdriver, push down, and turn all captive fasteners on the top cover 1/4 turn counter-clockwise.
2. Remove the top cover.
3. Voltages are checked at various locations in the equipment using a voltmeter (see figures FO-2, FO-3 and FO-4).

WARNING

When modules have been removed from the chassis and the power switch/circuit breaker (S1) is set on, high voltage may be present at the module connectors in the chassis. Use caution when working in these areas.

4. Some voltages may be checked on the rear panel connectors. Refer to Chapter 2 for pin-outs of these connectors. Some voltages may be checked by removing the module where the signal in question terminates, and checking the voltage at the connector in the chassis.

CAUTION

Set front panel power switch/circuit breaker to off (down), and disconnect AC IN connector (J2) before performing continuity checks. Allow 5 minutes for the main filter capacitors to discharge. Damage to the test equipment may occur if continuity checks are performed with input voltages applied to the equipment.

5. Using an ohmmeter, perform continuity checks using figures FO-2, FO-3, and FO-4.

CHAPTER 6 PREPARATION FOR RESHIPMENT

6-1 INTRODUCTION. This chapter contains information to prepare the equipment for reshipment including disassembly and removal from the rack mount, packaging, and shipping.

6-2 DISASSEMBLY AND REMOVAL. To disassemble and remove the PS-7130A-1 from the rack mount, perform the following procedures:

1. Ensure the front panel switch/circuit breaker is set off (down).
2. Loosen screws holding chassis in mounting rack assembly.
3. Slide drawer to the fully extended position.
4. Disconnect the AC power cable from the power source.
5. Disconnect all cables from the rear panel.

CAUTION

Do not support the weight of the unit by the front panel alone. The chassis may bend or warp. Use chassis slides or a suitable support shelf.

6. Remove the power supply from the rack mount.
7. Remove both slide rails and save the hardware.

6-3 PACKAGING.

NOTE

The power supply should be packed in the original shipping container if available

To package the equipment for reshipment perform the following steps:

1. Ensure that there is sufficient foam packing material in the shipping container to protect the unit from any hard impact.
2. Cover the unit with foam or bubble-type packing material.
3. Place the unit in the center of the shipping container.
4. If using a cardboard packing carton, securely tape the seams of the carton's top cover, bottom cover, and side flaps with reinforced packing tape.
5. Attach labels or stamp in indelible ink the word **FRAGILE** on the top, bottom, and all sides of the container.

6-4 SHIPPING.

CAUTION

Unit contains parts and assemblies sensitive to damage by electrostatic discharge (ESD). Do not ship or store near strong electrostatic, electromagnetic, magnetic or radioactive fields.

There are no special shipping requirements for the unit. Commercial or military surface or air shipping services may be used.

CHAPTER 7 STORAGE

7-1 INTRODUCTION. This chapter contains information for storage of the equipment including environmental conditions and any special preservation requirements.

7-2 STORAGE ENVIRONMENT. The power supply should be stored indoors in the original shipping container (or similar container) as described in Chapter 6. The environment should be dry with a temperature range between -40 and +75°C.

CAUTION

Unit contains parts and assemblies sensitive to damage by electrostatic discharge (ESD). Do not ship or store near strong electrostatic, electromagnetic, magnetic or radioactive fields.

7-3 PRESERVATION. There are no special coverings or preservation materials required to store the power supply.

CHAPTER 8 PARTS LIST

8-1 INTRODUCTION. This chapter contains the parts list for replaceable parts at the operational maintenance level.

8-2 REPLACEABLE PARTS LISTING. Table 8-1 lists the replaceable parts for the unit. (See figure FO-4 for locations.)

Table 8-1 Replaceable Parts List.

Qty	Description	Part Number	Mfr ¹
4	Power Supply Module	2241-1104-1	CCI
1	Filler Panel, Front	2242-4412-1	CCI
1	Filler Panel, Rear	2242-4413-7	CCI
¹ Cubic Communications Inc.			

8-3 OPTIONAL PARTS LISTING. Table 8-2 lists the parts required if the optional T-4180 Exciter is to be installed inside the chassis of the PS-7130A-1

Table 8-2 Optional Parts List

Qty	Description	Part Number	Mfr ¹
1	Bracket, Front Right	2242-4405-7	CCI
1	Bracket, Front Left	2242-4405-8	CCI
2	Bracket, Rear	2242-4406-7	CCI
¹ Cubic Communications Inc.			

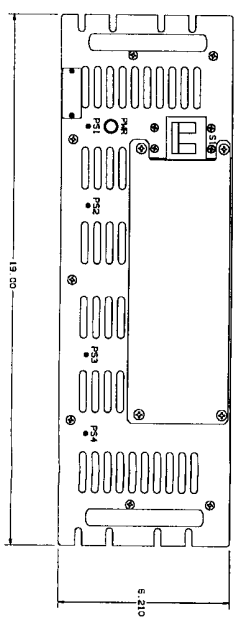
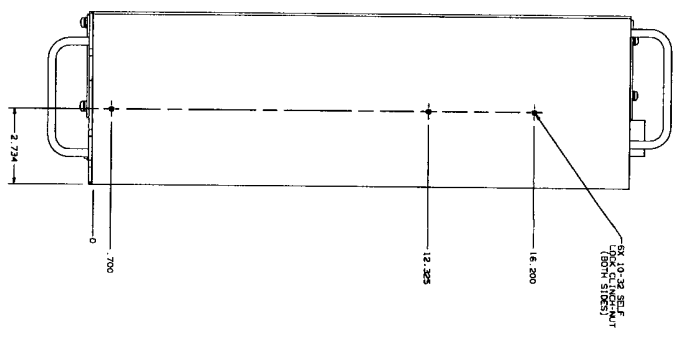
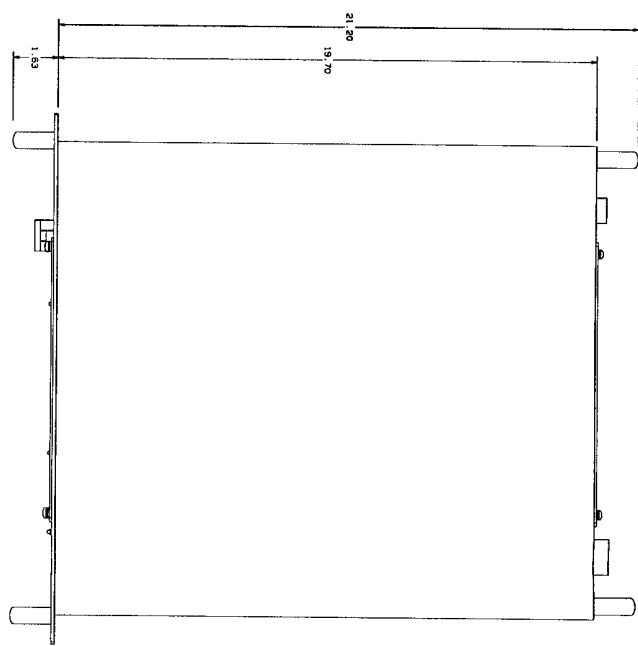

FO-1. PS-7130A-1 Outline and Mounting Drawing.

FP-1/(FP-2 blank)

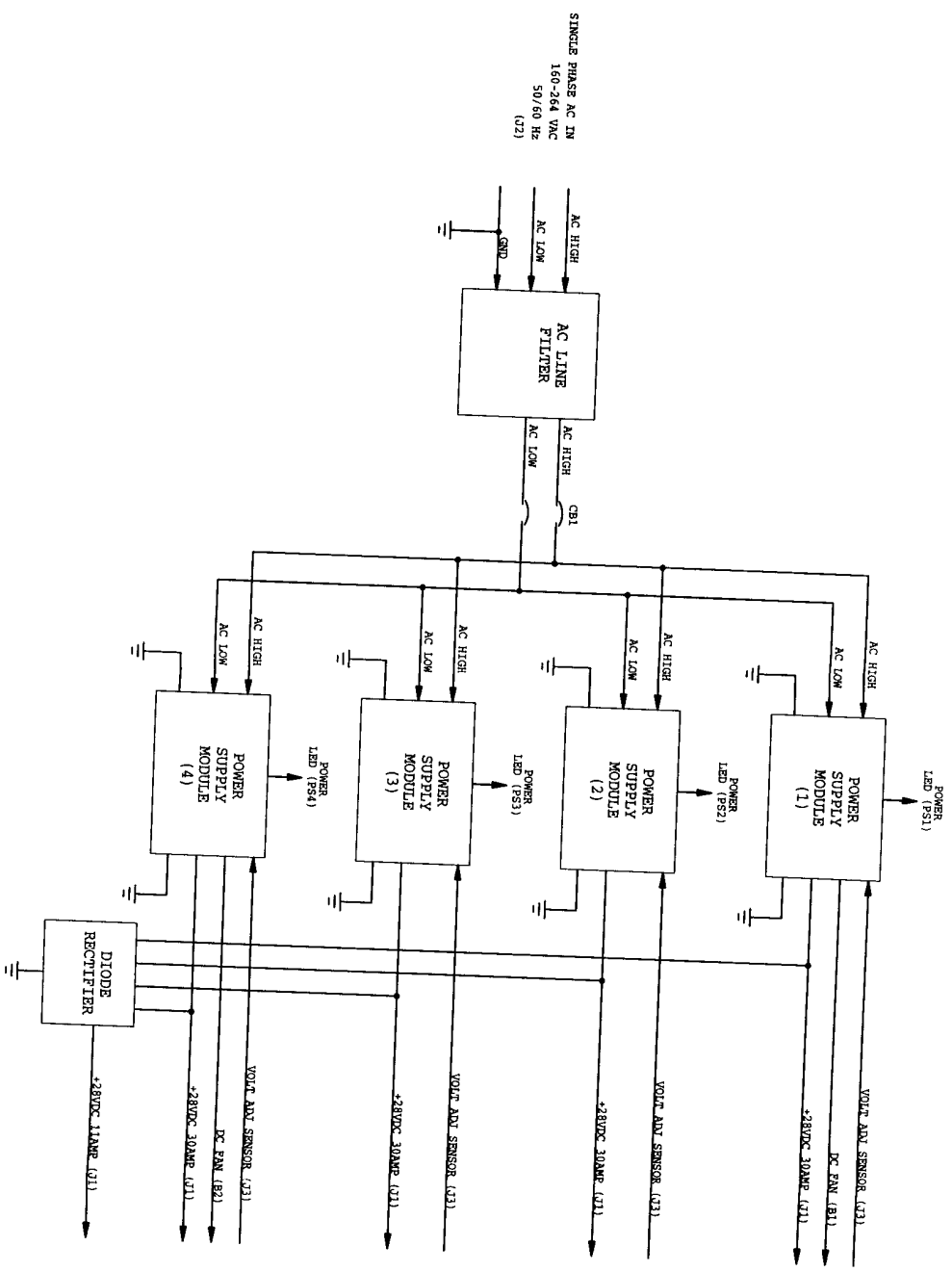

FO-2. PS-7130A-1 Block Diagram.

FP-3/(FP-4 blank)

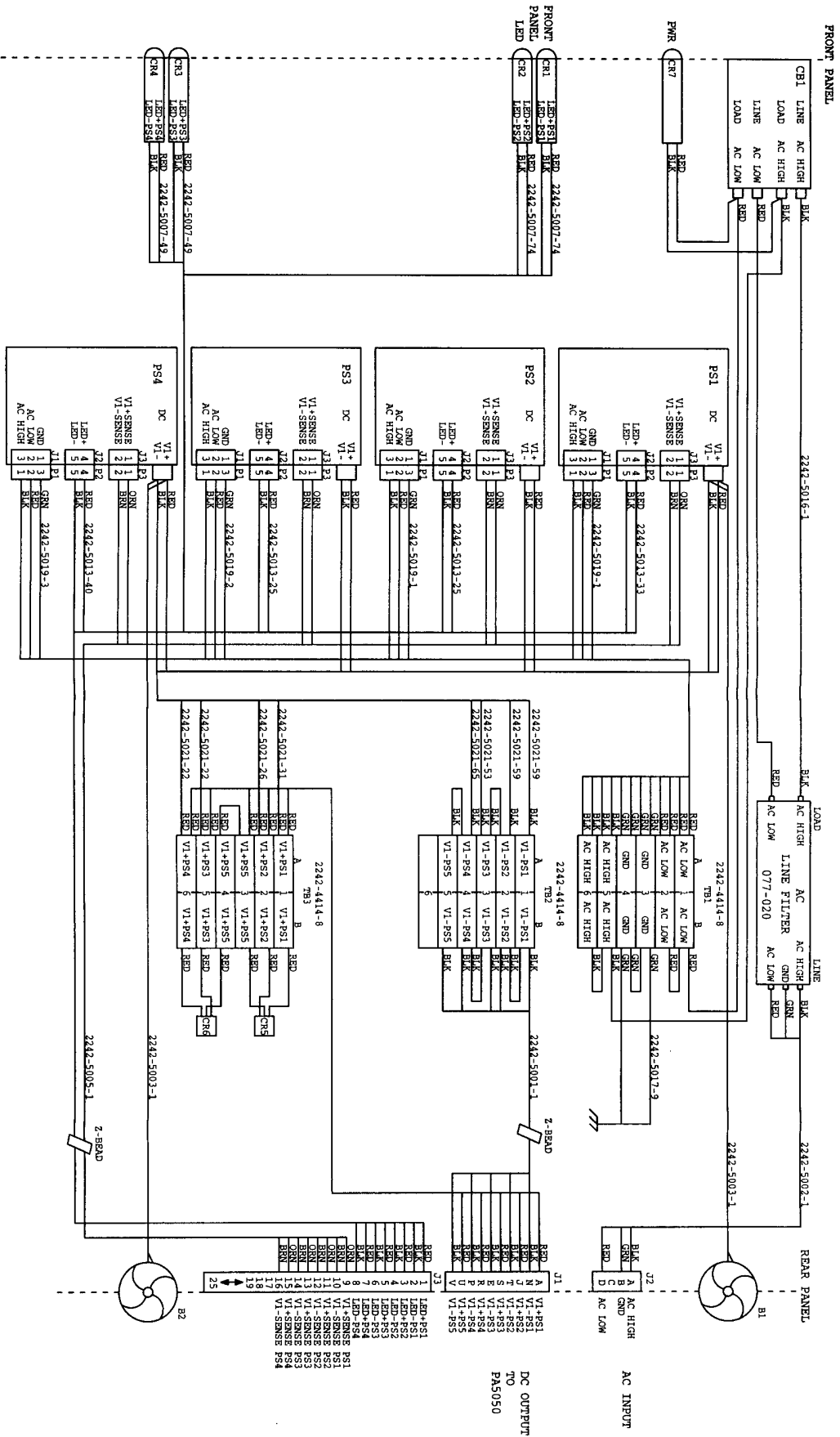

FO-3. PS-7130A-1 Interconnect Diagram.

FP-5/(FP-6 blank)

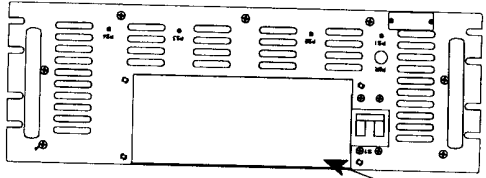

Filler Panel, Front

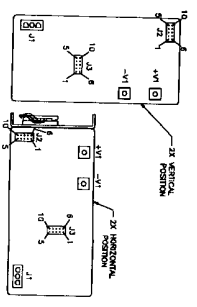
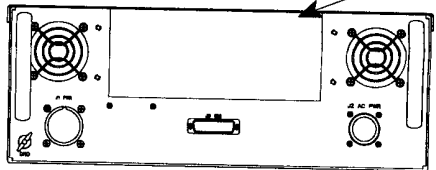
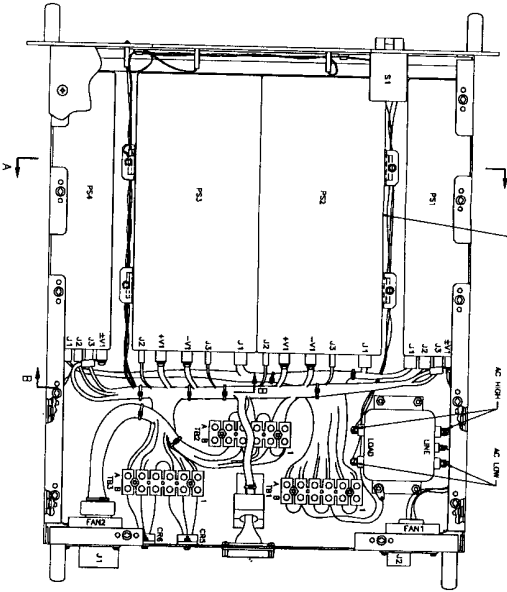
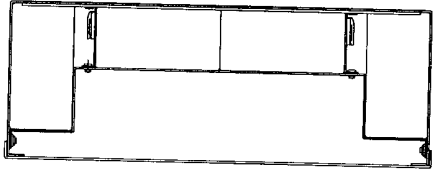

TECHNICAL MANUAL

OPERATION AND MAINTENANCE INSTRUCTIONS

OPERATIONAL LEVEL

**POWER AMPLIFIER, 1KW
MF - HF
PA-5050A**

(FCC VERSION)



Cubic Communications, Inc.
9535 Waples Street
San Diego, California 92121-2953

Telephone: (619) 643-5800 Telefax: (619) 643-5803

Manual Part No. 2241-1021-3

15 April 1998

RECORD OF CHANGES

CHANGE	DATE	TITLE OF BRIEF DESCRIPTIONS	ENTERED BY

FOREWORD

SCOPE

This manual contains information for the installer and operator to obtain best performance from the PA-5050A. The information includes: a general description, preparation for use and installation instructions, operating instructions, general theory of operation, maintenance instructions, preparation for reshipment, and parts list.

Component level maintenance is not included in this manual. Component level maintenance should be performed in the designated maintenance depot or the factory.

WARNING

Do not apply power to the equipment until the installation procedures in Chapter 2 have been successfully completed.

PROPRIETARY DATA

The information in this manual is the property of Cubic Communications Incorporated. Disclosure to a third party, either wholly or in part, without written consent from Cubic Communications Incorporated is prohibited.

CORRECTION NOTICE

The information in this manual is believed correct at publication date. If a difference is noted between the information in this manual and the equipment, contact the factory for clarification. Current and future editions will be corrected as necessary.

RIGHTS RESERVED

Cubic Communications Incorporated reserves the right to change the specifications, design, and fabrication methods of equipment at any time without notice.

RIGHTS RESERVED

The PA-5050A when use with the PS-7130A and T-4150/80-9 comprises the CTX-1000 System. This system is FCC certified for aeronautical base station usage. FCC identification number is NVSCTX-1000.

TABLE OF CONTENTS

<u>Chapter</u>		<u>Page</u>
1	GENERAL DESCRIPTION	1-1
1-1	INTRODUCTION	1-1
1-2	EQUIPMENT DESCRIPTION	1-1
1-3	EQUIPMENT FURNISHED	1-1
1-4	STORAGE DATA	1-1
1-5	TOOLS AND TEST EQUIPMENT	1-1
1-6	SAFETY PRECAUTIONS	1-1
2	PREPARATION FOR USE AND INSTALLATION INSTRUCTIONS	2-1
2-1	INTRODUCTION	2-1
2-2	UNPACKING AND INSPECTION	2-1
2-3	INSTALLATION	2-1
2-4	CONNECTIONS	2-2
2-5	INITIAL ALIGNMENT PROCEDURES	2-7
3	OPERATING INSTRUCTIONS	3-1
3-1	INTRODUCTION	3-1
3-2	OPERATION	3-1
3-3	EMERGENCY OPERATION	3-1
4	GENERAL THEORY OF OPERATION	4-1
4-1	INTRODUCTION	4-1
4-2	GENERAL THEORY OF OPERATION	4-1
	4-2.1 <u>Power Distribution</u>	4-1
	4-2.2 <u>Controller Board</u>	4-1
	4-2.3 <u>Display</u>	4-2
	4-2.4 <u>Filter Driver Board</u>	4-2
	4-2.5 <u>Attenuator/Pre-Driver Board</u>	4-2
	4-2.6 <u>PA Driver Module</u>	4-2
	4-2.7 <u>Splitter Module</u>	4-2
	4-2.8 <u>PA Module</u>	4-2
	4-2.9 <u>Combiner Module</u>	4-3
	4-2.10 <u>Lowpass Filter Board</u>	4-3
	4-2.11 <u>Bi-Directional Coupler</u>	4-3
5	MAINTENANCE INSTRUCTIONS	5-1
	Section I. PREVENTIVE MAINTENANCE	5-1
5-1	INTRODUCTION	5-1
5-2	CLEANING AND LUBRICATION	5-1
5-3	INSPECTION	5-1
5-4	PERFORMANCE VERIFICATION	5-1
	Section II. CORRECTIVE MAINTENANCE	5-2
5-5	TROUBLESHOOTING	5-2
	5-5.1 <u>Troubleshooting Philosophy</u>	5-2
	5-5.2 <u>Troubleshooting Procedure</u>	5-2
	5-5.2.1 <u>Fault Identification</u>	5-2
	5-5.2.2 <u>Initial Checks</u>	5-2
	5-5.2.3 <u>PA Power Checks</u>	5-2

TABLE OF CONTENTS (Cont.)

<u>Chapter</u>		<u>Page</u>
	5-5.3 <i>Module Replacement</i>	5-4
	5-5.3.1 <i>Removal</i>	5-4
	5-5.3.2 <i>Replacement</i>	5-4
	5-5.3.3 <i>Calibration</i>	5-4
	5-5.4 <i>Voltage/Continuity Checks</i>	5-5
6	PREPARATION FOR RESHIPMENT	6-1
6-1	INTRODUCTION	6-1
6-2	DISASSEMBLY AND REMOVAL	6-1
6-3	PACKAGING	6-1
6-4	SHIPPING	6-1
7	STORAGE	7-1
7-1	INTRODUCTION	7-1
7-2	STORAGE ENVIRONMENT	7-1
7-3	PRESERVATION	7-1
8	PARTS LIST	8-1
8-1	INTRODUCTION	8-1
8-2	REPLACEABLE PARTS LISTING	8-1
	APPENDIX A: REMOTE CONTROL CABLE	A-1
A-1	INTRODUCTION	A-1
A-2	DRAWING	A-1

LIST OF ILLUSTRATIONS

<u>Figure</u>		<u>Page</u>
1-1	PA-5050A Front View	1-2
2-1	PA-5050A Rear Panel	2-3
3-1	PA-5050A Front Panel Controls and Indicators	3-2
FO-1	PA-5050A Outline and Mounting Drawing	FP-1
FO-2	PA-5050A Block Diagram	FP-3
FO-3	PA-5050A Interconnect Diagram	FP-5
FO-4	PA-5050A Replaceable Parts Locator Diagram	FP-7

LIST OF TABLES

<u>Table</u>		<u>Page</u>
1-1	PA-5050A Specifications	1-3
1-2	Items Furnished and Required	1-4
1-3	Recommended Tools and Test Equipment (Or Equivalent)	1-4
2-1	Rear Panel Connections	2-2
2-2	DC POWER (J3) Pin Descriptions	2-4
2-3	SIGNAL (J4) Pin Descriptions	2-5
2-4	REMOTE CONTROL (J5) Pin Descriptions	2-6
3-1	Front Panel Controls and Indicators	3-1
3-2	PA-5050A Serial Bus Command and Status Messages	3-3
5-1	Front Panel LED Interpretation.	5-3
8-1	Replaceable Parts List	8-1

CHAPTER 1 GENERAL DESCRIPTION

1-1 INTRODUCTION. This chapter contains a description of the equipment supplied, equipment required but not supplied, storage data, and recommended tools and test equipment.

1-2 EQUIPMENT DESCRIPTION. The PA-5050A linear power amplifier (figure 1-1) is a solid state unit that provides 1 kilowatt power amplification of RF signals between 1.6 and 30 MHz. The unit contains 4 independent power amplifier (PA) modules. If one or more of the PA modules fail, the unit will still operate with reduced power out.

The front panel contains a PWR LED with each PA module containing an individual PWR and FLT LED, and a multifunction display. Input power to the PA-5050A is derived from a separate +28V DC power supply providing five separate +28V DC outputs. The CCI PS-7130A meets this requirement and is recommended for optimum performance. Four independent modular PA modules provide the four stages of amplification. Each PA module is identical and interchangeable. When an individual PA module's gain is less than +10 dB, the circuitry turns on the FLT LED. The individual module can then be removed and replaced.

The rear panel contains connectors for the transmitter/exciter low power RF input, high power RF output to the antenna, remote control input, DC power and signal input, and a ground lug.

Four internal fans per PA module provide cooling across the heatsink of the unit.

Refer to table 1-1 for specifications of the equipment.

1-3 EQUIPMENT FURNISHED. Table 1-2 lists the items furnished, items required but not supplied, and optional items.

1-4 STORAGE DATA. Refer to Chapter 7 for storage data.

1-5 TOOLS AND TEST EQUIPMENT. Table 1-3 lists recommended tools and test equipment for operational level maintenance. There are no special tools or test equipment required.

1-6 SAFETY PRECAUTIONS. Safety precautions are presented in this manual preceded by the word WARNING or CAUTION just before the point where the hazard is likely to be encountered. Warnings and cautions are defined as follows:

WARNING

Refers to a procedure or practice that, if not correctly followed, could result in injury, death, or long term health hazard.

CAUTION

Refers to a procedure or practice that, if not correctly followed, could result in damage to, or destruction of equipment.

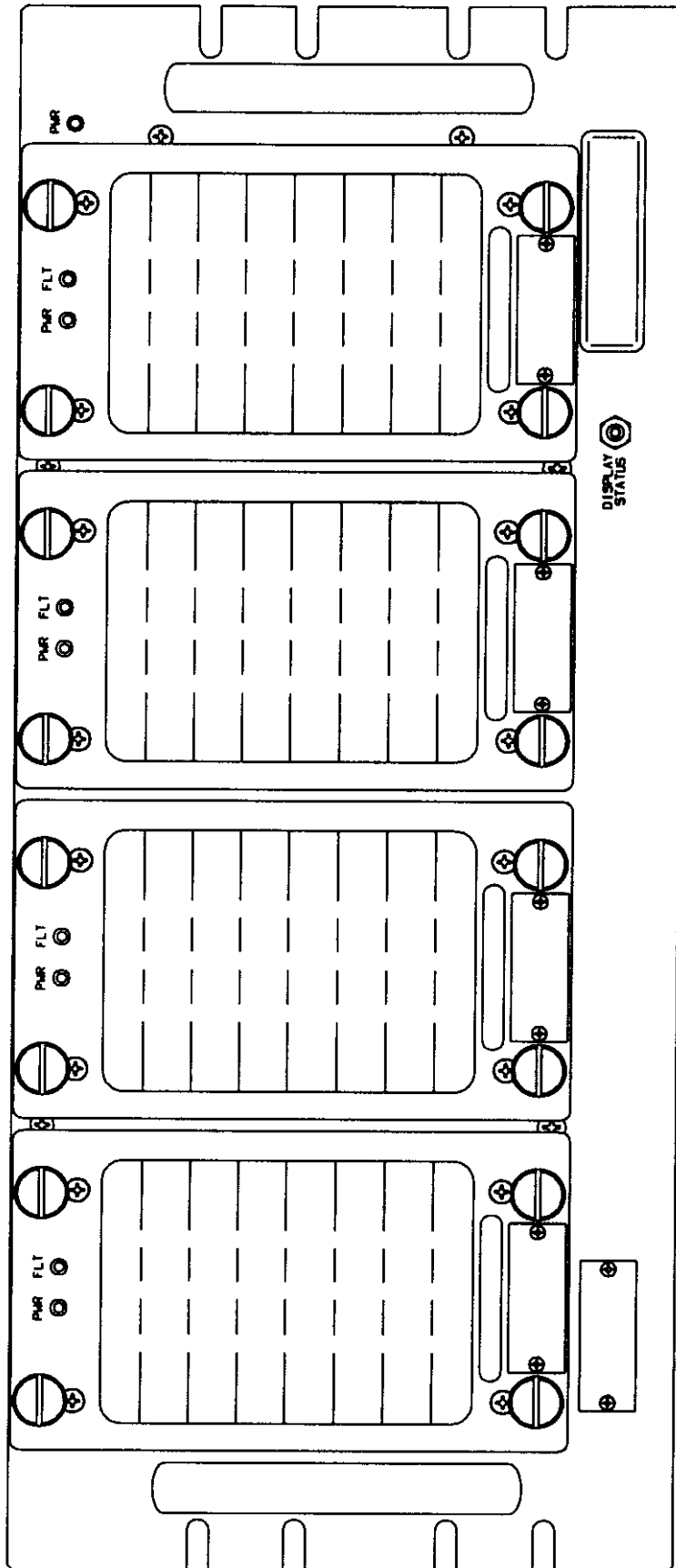

Figure 1-1 PA-5050A Front View.

Table 1-1 PA-5050A Specifications.

Item	Specification																
ELECTRICAL REQUIREMENTS																	
Frequency Range	1.6 - 30.0 MHz																
Power Output	1 kW peak. (900 w from 28MHz - 30 MHz) Rated for 100% continuous duty SSB, CW, AM, or FSK.																
Drive Level	20 to 100 milliwatts input for 1000 watts output.																
Intermodulation Distortion	(dB below 1 kW PEP) 3rd order 32 dB, 5th order 37 dB typical.																
Filter Bands (in MHz)	<table border="0"> <tr> <td>Band 0</td> <td>1.60 - 2.31</td> <td>Band 4</td> <td>6.94 - 9.99</td> </tr> <tr> <td>Band 1</td> <td>2.32 - 3.33</td> <td>Band 5</td> <td>10.00 - 14.41</td> </tr> <tr> <td>Band 2</td> <td>3.34 - 4.80</td> <td>Band 6</td> <td>14.42 - 20.79</td> </tr> <tr> <td>Band 3</td> <td>4.81 - 6.93</td> <td>Band 7</td> <td>20.80 - 30.00</td> </tr> </table>	Band 0	1.60 - 2.31	Band 4	6.94 - 9.99	Band 1	2.32 - 3.33	Band 5	10.00 - 14.41	Band 2	3.34 - 4.80	Band 6	14.42 - 20.79	Band 3	4.81 - 6.93	Band 7	20.80 - 30.00
Band 0	1.60 - 2.31	Band 4	6.94 - 9.99														
Band 1	2.32 - 3.33	Band 5	10.00 - 14.41														
Band 2	3.34 - 4.80	Band 6	14.42 - 20.79														
Band 3	4.81 - 6.93	Band 7	20.80 - 30.00														
Input VSWR	Less than 2:1																
Output Impedance	50 ohms. Gradual power shutdown above 100w reflected power.																
Input Voltage	+28VDC, 25A (4 sources), and +28VDC, 11A (1 source).																
ENVIRONMENTAL																	
Ambient Temperature	0 to +50°C operating, -40 to +75°C storage																
Humidity	95% (non-condensing)																
Cooling	Forced air cooling with four fans per each PA module.																
Thermal Monitoring	One thermal switch continually monitors the driver and four additional thermal switches continually monitors each power supply. If an over temperature condition (ie above 85° C) should occur in any one unit, power to the driver or the a PA module will automatically shut off. If power to the driver is shut off, the PA modules will not work until the temperature of the driver drops below 85° C.																
INTERFACE CONNECTORS																	
	<table border="0"> <tr> <td><u>On Chassis</u></td> <td><u>Mates With</u></td> </tr> </table>	<u>On Chassis</u>	<u>Mates With</u>														
<u>On Chassis</u>	<u>Mates With</u>																
INPUT	N-type (F) N-type (M)																
ANT	N-type (F) N-type (M)																
DC POWER	2241-4304-1 2241-4304-4 (CCI P/N)																
REMOTE CONTROL (RS-485, RS-232)	25 - D Sub (F) 25 - D Sub (M)																
SIGNAL	25 - D Sub (F) 25 - D Sub (M)																
PHYSICAL																	
Size	7.75 in. high x 19 in. wide x 21.2 in. deep (front panel to rear handles)																
Weight	Approx. 75 pounds																

Table 1-2 Items Furnished and Required.

Part No.	Qty	Nomenclature	Furn./Reqd./Opt.
2241-1000-3	01	PA-5050A Power Amplifier (FCC I.D. # NVSCTS-1000)	Furnished
2241-1021-3	01	Technical Manual, Operation and Maintenance Instructions, POWER AMPLIFIER, PA-5050A	Furnished
2242-1000-1	01	Cubic PS-7130A. (Four independent Power Sources @ +28VDC ±10%, 25 amperes., and one source @ +28VDC ±10%, 11 amperes.)	Furnished
2607-1000-9	01	Cubic T-4150/T-4180 (MF-HF Transmitter/Exciter, 20-100 milliwatts PEP)	Furnished
2241-5023-1	01	Remote Control Cable, PA to Exciter	Optional, furnished with FCC system
-	01	Antenna system and attaching cables	Reqd. Not supplied

Table 1-3 Recommended Tools and Test Equipment (Or Equivalent).

Part No.	Nomenclature	Manufacturer
-	Flat-blade screwdriver, 6 in.	Standard issue
-	No. 2 Phillips screwdriver, 6 in.	Standard Issue
8050A	Digital multimeter	Fluke
8890-300	RF Coaxial Load, 1 kW, 50 ohms	Bird
4421	RF Power Meter	Bird
4021	Directional Power Sensor	Bird

CHAPTER 2

PREPARATION FOR USE AND INSTALLATION INSTRUCTIONS

2-1 INTRODUCTION. This chapter contains unpacking, inspection, installation, connections, and initial alignment procedures for the PA-5050A.

2-2 UNPACKING AND INSPECTION. To unpack and inspect the PA-5050A for damage, perform the following procedures:

1. Inspect the shipping carton for damage before unpacking the PA-5050.

NOTE

If the carton is damaged, open the carton in the presence of a shipping carrier agent if possible. If damage is found after the PA-5050A is unpacked, retain the carton and packing materials for inspection.

2. Open the carton and remove the foam packing material on top of the PA-5050A.

WARNING

Two-man lift. Unit weighs approx. 75 pounds. Be careful when lifting the unit to avoid injury or damage to the equipment.

CAUTION

Do not support the weight of the unit by the front panel alone. The chassis may bend or warp. Use chassis slides or a suitable support shelf.

3. Lift the PA-5050A from the carton.

NOTE

The carton should be saved for possible reshipment.

4. Inspect the PA-5050A for external damage including dents and scratches. Do not attempt to operate the PA-5050A if damage is found.

2-3 INSTALLATION. The PA-5050A is designed for rack slide mounting in a relatively dust free environment with an ambient temperature range between 0 and +50°C.

CAUTION

Ensure slide mounting screws are of the proper length. If screws are too long internal equipment may be damaged.

NOTE

See figure FO-1 for clearance requirements and mounting details.

1. Securely mount the outer section of the slides to the rack cabinet being sure to select the correct mounting holes.
2. Attach indicated right and left slide rails to each side of unit.
3. Before tightening the mounting screws, slide the chassis assembly into the rack mounted portion of the slides and adjust the hardware position as required for a smooth sliding fit.
4. Remove unit from rack and securely tighten all hardware.

2-4 CONNECTIONS. Refer to table 2-1 and connect the ground lug, RF Input, RF Output, Power/Signals, and Remote Control cables to the unit. (See figure 2-1.)

NOTE

Refer to the CCI T-4150/80 and/or PS-7130A Technical Manuals if used.

WARNING

Severe injury or **DEATH** can result if bodily contact is made with an ungrounded chassis should high leakage current or a short-circuit condition occur.

Table 2-1 Rear Panel Connections.

Name	Type	Mating Type	Description
INPUT (J1)	N-type (F)	N-type (M)	RF input 1.6 to 30 MHz, 20 - 250 milliwatts.
ANT (J2)	N-type (F)	N-type (M)	RF output 1.6 to 30 MHz, 1,000 watts
PWR (J3)	(320-107)	(320-106)	+28V DC input voltages, control, and confidence signals to/from the power supply (CCI PS-7130A). Table 2-2 lists the signals on each pin of the connector.
SIGNAL (J4)	25 - D Sub (F)	25 - D Sub (M)	LED and 28V Sense lines between PS-7130A and PA-5050A. Table 2-3 lists the signals on each pin of the connector.
SERIAL REMOTE (J5) (RS-485)	25 - D Sub (F)	25 - D Sub (M)	RS-485 input. Normally connected to CCI T-4150/80 exciter. Table 2-4 lists the signals on each pin of the connector.
GND	Stud/Wing nut	---	This connection is required for ground loop interference reduction, leakage current and/or short circuit-current paths. Use 3/4-inch wide braided lead and connect to unpainted, clean, bare metal on platform ground.
NOTE: Part numbers in parenthesis (000-000) indicate CCI part number if applicable.			

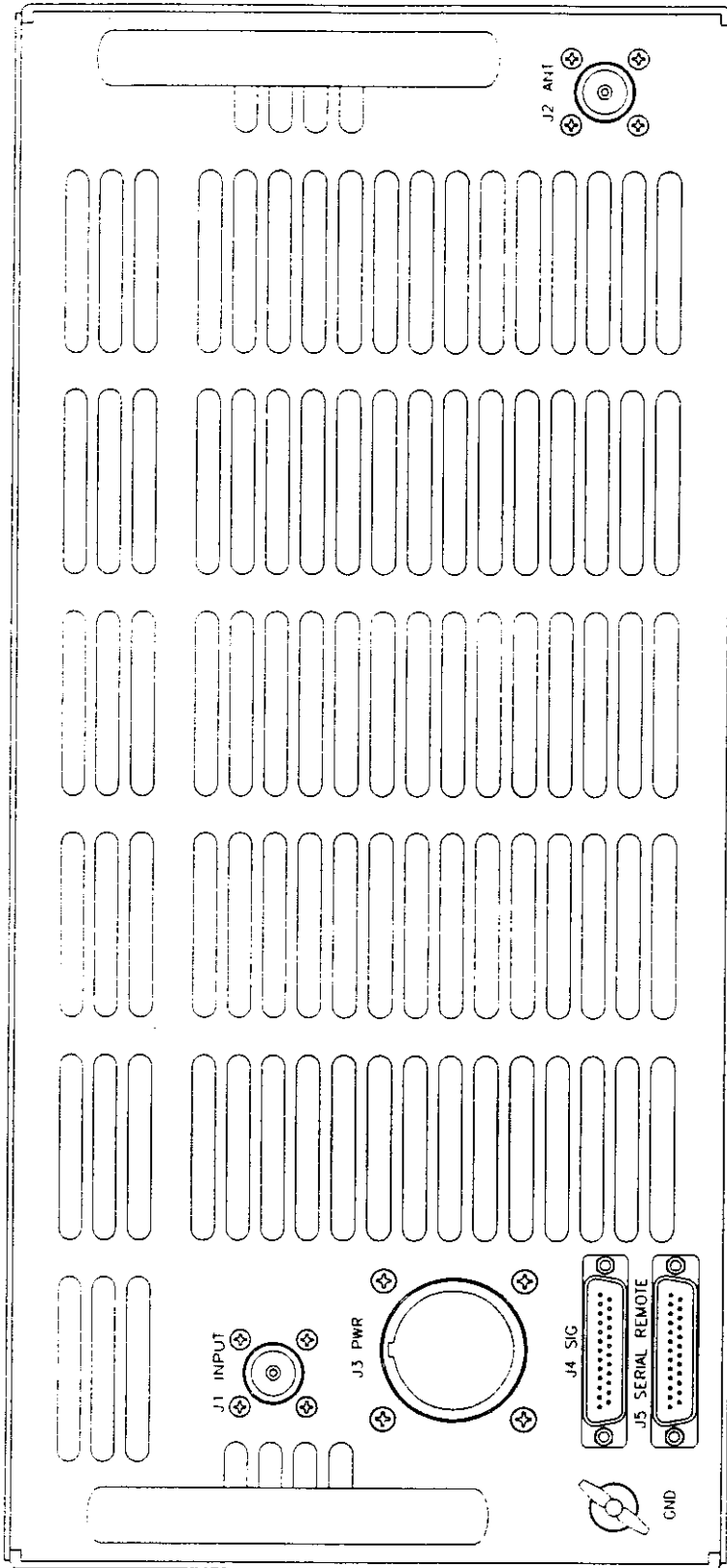

Figure 2-1 PA-5050A Rear Panel.

Table 2-2 DC POWER (J3) Pin Descriptions.

Pin	Signal	Remarks
A	+28VDC U1	PS1 Input
N	GND U1	PS1 Input
J	+28VDC U2	PS2 Input
T	GND U2	PS2 Input
S	+28VDC U3	PS3 Input
E	GND U3	PS3 Input
R	+28VDC U4	PS4 Input
P	GND U4	PS4 Input
U	+28VDC U5	AUX Input
V	GND U5	AUX Input

Table 2-3 SIGNAL (J4) Pin Descriptions.

Pin	Signal	Remarks
1	#1 LED+, 28V	#1 Power Supply J2 pin 4
2	#1 LED-, GND	#1 Power Supply J2 pin 5
3	#2 LED+, 28V	#2 Power Supply J2 pin 4
4	#2 LED-, GND	#2 Power Supply J2 pin5
5	#3 LED+, 28V	#3 Power Supply J2 pin 4
6	#3 LED-, GND	#3 Power Supply J2 pin 5
7	#4 LED+, 28V	#4 Power Supply J2 pin 4
8	#4 LED-, GND	#4 Power Supply J2 pin 5
9	#1 Sense+	Power Supply J3 pin 1
10	#1 Sense-	Power Supply J3 pin 2
11	#2 Sense+	Power Supply J3 pin 1
12	#2 Sense-	Power Supply J3 pin 2
13	#3 Sense+	Power Supply J3 pin 1
14	#3 Sense-	Power Supply J3 pin 2
15	#4 Sense+	Power Supplu J3 pin 1
16	#4 Sense-	Power Supply J3 pin 2
17	(Opt) #5 Sense+	Power Supply J3 pin 1
18	(Opt) #5 Sense-	Power Supply J3 pin 2
19	(Opt) #5 LED+, 28V	Power Supply J2 pin 4
20	(Opt) #5 LED-, GND	Power Supply J2 pin 5
21-25	NC	

Table 2-4 REMOTE CONTROL (J5) Pin Descriptions.

Pin	Signal	Remarks
1	TX KEY	Ground to Key
2	TXD	RS-232
3	RXD	RS-232
4	RTS	RS-232
5	CTS	RS-232
6	NC	
7	GND	
8-13	NC	
14	TX+	RS-485 SDA
15	TX-	RS-485 SDB
16	RX+	RS-485 RDA
17	RX-	RS-485 RDB
18	NC	
19	UpTXD	Upload
20	GND	UpGND
21	UpRXD	Upload
22	UpCTS	Upload
23-25	NC	

2-5 INITIAL ALIGNMENT PROCEDURES.

NOTE

This procedure is used only when the system is turned on for the first time or when the T-4180 exciter is changed.

Setting PAPI Manually::

1. If the PS-7130A and the PA-5050A are on, turn them off.
2. Press the button on the PA-5050A and hold down while turning on the PS-7130A.
3. The LED readout will display "TURN OFF TO ABORT". Release the button. Press the button when the readout displays "PRESS TO ERASE" to allow the PA-5050A to continue. The readout will display "PAPI NOT SET".
4. On the T-4180, set the "FREQ" to 16 MHz and "LEVEL" to +24 dBm.
5. Press the "NEXT" key. Press the "PAPOW" key. Press the "100W" key.
6. The PA-5050A is now prepared to pre-set the attenuator for 100 watts. Key the T-4180. When the PA-5050A power stabilizes (between 90 and 130 watts on the PA-5050A readout) unkey the exciter.
7. Tune to the desired operating frequency and set the "PAPOW" at 1 k watt. The PA-5050A system is ready to use.

CAUTION

The "PAPOW" must be reset whenever the frequency is changed more than 2MHz

CHAPTER 3 OPERATING INSTRUCTIONS

3-1 INTRODUCTION. This chapter contains operating instructions for the PA-5050A linear power amplifier. A separate power supply source, transmitter/exciter, and antenna system are required. Refer to the documentation supplied with the power supply, transmitter/exciter, and antenna system for operation of that equipment.

3-2 OPERATION. Operation is performed using the front panel controls and indicators. (See figure 3-1.) Table 3-1 lists the front panel controls and indicators and their functions.

To turn on, and initially set-up the PA-5050A, perform the following procedures:

1. Apply input power to the equipment from the external power supply.
2. Observe PWR LED on PA-5050A chassis, and all four PA modules light.
3. The PA-5050A is remotely controlled using an RS-485 bus connected to the exciter. Table 3-2 lists the ASCII commands available.
4. During operation, press the DISPLAY STATUS button on the front panel to cycle through the different status messages on the front panel display.
5. Observe that the FLT LED on each PA module does not light during transmission.
6. To shut down the PA-5050A remove input power. (Turn the POWER switch to off (down) on the PS-7130A).

Table 3-1 Front Panel Controls and Indicators.

Control	Function
PWR LED (on chassis)	Indicates power is applied to PA-5050A.
PWR LED (on each PA module)	Indicates power is applied to individual PA module. Power loss may be a result of a circuit problem or an over temperature condition..
FLT LED (on each PA module)	Indicates PA module gain is less than +10 dBt. LED goes off when gain is greater than +10 dB with some modulated signals. The FLT LED may momentarily flicker.
DISPLAY STATUS button	<p>Works independently or in conjunction with keying the microphone.</p> <p>Microphone keyed/button not pressed: FWD xx REV xx Microphone keyed/button pressed: VSWR X.X:1 Microphone not keyed/button not pressed: FREQ xxxxxxxx Microphone not keyed/button pressed: ATTN xxxx</p> <p>Note: 'FWD, REV, and VSWR values are not valid below 50 watts output power.</p>

3-3 EMERGENCY OPERATION. There are no emergency operating procedures for the unit. Power is removed from the unit by turning off the power at the input power supply (PS-7130A front panel switch/circuit breaker if installed).

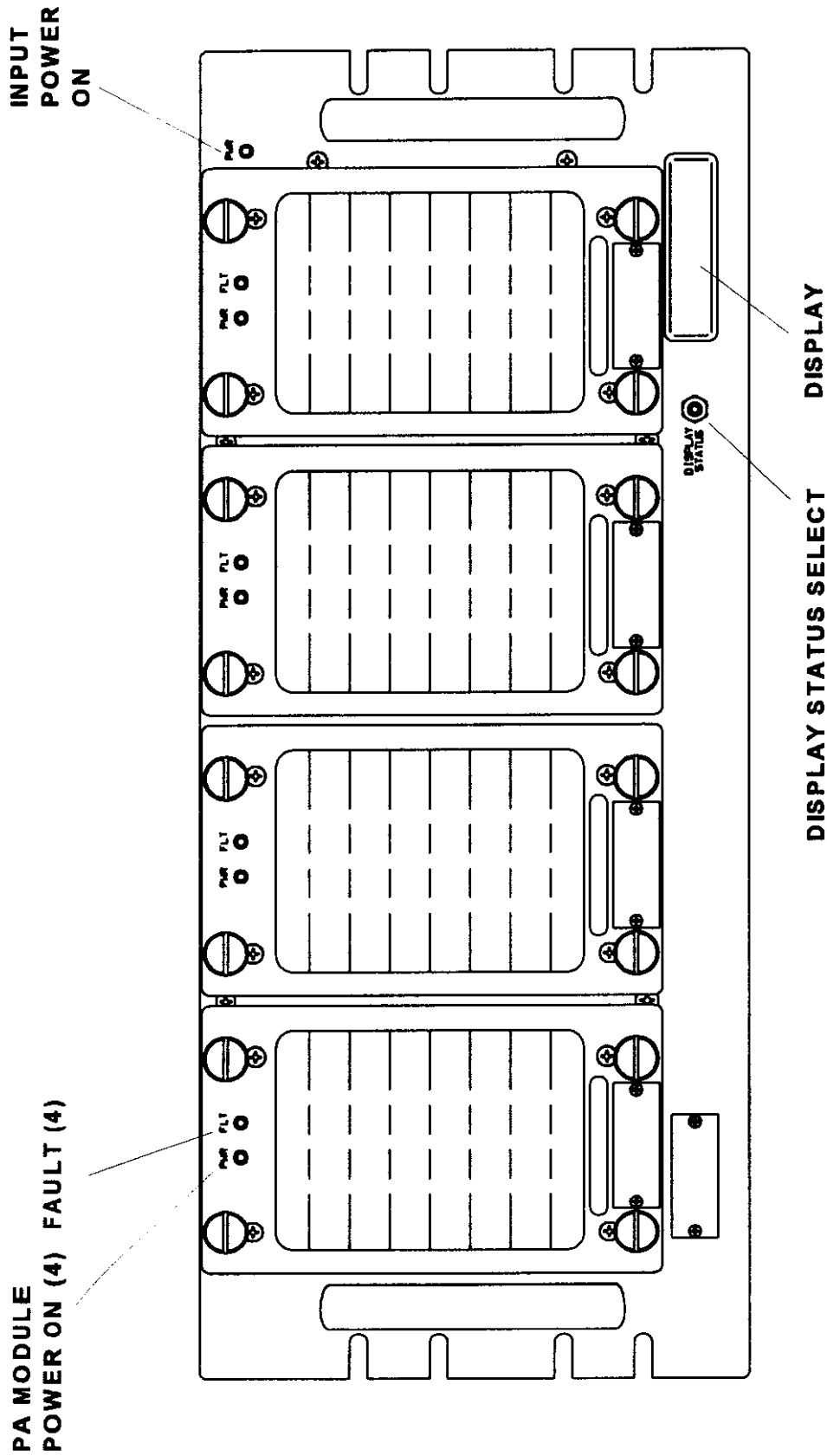

Figure 3-1 PA-5050A Front Panel Controls and Indicators.

Table 3-2 PA-5050A Serial Bus Command and Status Messages.

Syntax	Reply	Description
Command Messages		
PAF12345678	---	Set operating frequency in Hz. Range 1.6 - 30 MHz. This will select the appropriate low pass filter.
PAP#	---	Set the power output. Valid ranges are 1=100W, 2=500W, 3=1KW below 28 MHz & 900W at 28 MHz and above
PT #	---	Software TxKey. 1 = TX, 0 = RX
ATNXXxx	---	Set front end attenuation value 00.00 to 32.00 dB. (XX.xx)
PER	---	Erases the lower user block of flash memory where the calibration values are stored.
Status Messages		
PAF?	PAFxxxxxxxx	Where xxxxxxxx is the frequency in Hz.
PA?	F, SWR, FWD, REV, ATN, FLT, KEY, BND, OT	Request Power Amplifier Status Message. This will reply with a complete status message of all settings.
SWR?	SWRxx	Where xx is in the range of 1.0 to 6.0. (e.g. SWR13 indicates a SWR of 1.3:1) ¹ .
FWD?	FWDxxxx	Where xxxx is measured forward power in watts. Range of 0 to 1999 ¹ .
REV?	REVxxx	Where xxx is measured reverse power in watts. Range of 0 to 999 ¹ .
ATN?	ATNxxxx	Where xxxx is the current front end attenuation setting. Range 0 to 32 dB. (XX.xx)
FLT?	FLTxxxxx	Where xxxxx is fault status of each power module in the format: Driver:PA1:PA2:PA3:PA4. 1=FAULT 0=NONE
FLTA?	FLTAxxxxxxxxxxx	Accumulated Fault listing. Shows all faults that have occurred since power-up. First 5 positions are the same as OT? and the next 5 positions are the same as FLT?
KEY?	KEYx	Where x is the transmit key status. 1=KEYED 0=IDLE
OT?	OTxxxxx	Where xxxxx is over temp shutdown status of each power module in the format: Driver:PA1:PA2:PA3:PA4. 1=SHUTDOWN 0=NORMAL

All messages use the following format:

```

    |STX|1 2 3|P A F 1 2 5 0 0 0 0 0 SP PAP 2|CR| |
    |  |  |  |  /  |  |
    |---| -Adr- |-----Data Field---| / |---|
    /                                     /   \
  
```

Start of Transmission (ASCII code 02)

ASCII Space Character

Carriage Return

Adr: Address set to 123 (range 0 to 254, 255 reserved for broadcast mode)

Data Field: Separate commands by a space. (Example above = set frequency to 12.5 MHz (space) power out to 500W)

Note: ¹FWD, REV, and VSWR values are not valid below 50 watts output power.

CHAPTER 4 GENERAL THEORY OF OPERATION

4-1 INTRODUCTION. This chapter contains a block diagram description of the PA-5050A linear power amplifier. The following paragraphs describe operation of the PA-5050A (see figure FO-2).

4-2 GENERAL THEORY OF OPERATION.

4-2.1 Power Distribution. Power is applied to the rear panel of the unit on connector J1. Five individual +28V DC inputs are required to operate the equipment. Four of the +28V inputs at 25 amperes are applied directly to each of the four PA modules and their associated fans. The other +28V input at 11 amperes is applied to the Attenuator/ Pre-driver module, PA Driver module, Lowpass Filter board, and a DC-DC converter on the Filter/Driver board that produces +12V, -12V, and +5V DC voltages for the internal circuits.

4-2.2 Controller Board. The controller board provides all necessary control signals for the unit using the external RS-485 remote control bus and internal sensors. The controller board receives control signals on the bus from the Transmitter/Exciter on rear panel connector J5, and provides status and data information on the front panel display. Control signals to/from the internal circuits are described as follows:

VVA ATTN	Analog signal used to fine tune the attenuation (0 - 2.0 dB) of the Attenuator Pre-Driver
ATTN (0-3)	Digital outputs to coarse tune the attenuation (0 - 30 dB, in 2 dB steps) of the Attenuator Pre-Driver via Filter/Driver circuits
LP (0-2)	Digital outputs to select correct lowpass filter for the selected frequency
DRIVER GATE	Gates PA Driver on during transmitter/exciter key. Gates PA Driver off during unkey, or filter change.
PAGATE	Gates PA modules on during transmitter/exciter key. Off during unkey, or filter change.
OE/SE	Control signals to select and output data from MUX
INMUX	Mux data signal input includes fault data from PA Modules and external power supplies
FWD DET	Detected forward power input used for display and high power limiting
REFL DET	Detected reflected power used for display, calculations, VSWR, and reflected power limiting
DISPLAY STATUS SWITCH	Front panel switch input used to step through display
MSTR PWR LED	+5V for front panel LED
TX±	RS-485 transmit data (2 lines)
RX±	RS-485 receive data (2 lines)
TX KEY	Transmitter keyline from external transmitter/exciter used to gate the PA Driver and PA Modules.

4-2.3 Display. The Display board contains a liquid crystal alphanumeric display that provides an indication of forward power, reflected power, attenuation and frequency. When the front panel DISPLAY STATUS switch is pressed, the display shows the alternate information.

4-2.4 Filter Driver Board. The Filter/Driver board contains four separate circuits:

DC-DC Converter - converts the +28VDC input power to +12, -12, and +5 VDC for use by the internal circuits.

Filter Driver - contains logic drivers for signals from the Controller board to the Low Pass Filter board, PA Driver module, and PA modules.

MUX - provides the interface between the PA Modules and Controller board. Also provides LED \pm signals for the external power supply.

Detector - converts the sampled RF from the Bi-Directional Coupler to DC levels proportional to the forward and reflected power applied to the antenna. These DC voltages are then applied to the Controller board as FWD DET and REFL DET signals. It also provides the SHUTDOWN signal to the Attenuator/Pre-Driver if excessive forward or reflected power is sensed.

4-2.5 Attenuator/Pre-Driver Board. The RF IN signal from the transmitter/exciter enters the PA-5050A on rear panel connector J1 where it is applied to the Attenuator/Pre-Driver board. The signal is attenuated and then amplified to provide the correct drive level for the PA modules to maintain the 1000 Watts of output power.

Attenuation controls from the Controller board, through the Filter/Driver board, determine the amount of attenuation to be applied to the signal based on the forward and reflected output power. The four digital ATTN lines (0-3) provide coarse attenuation through the Filter/Driver board from 0 to 30 dB in 2 dB steps, while the analog VVA ATTN signal provides the fine attenuation control continuously from 0 to 2.5 dB. If the Detector circuits on the Filter/Driver board sense excessive forward or reflected power the SHUTDOWN signal adds up to 18 dB of attenuation control as required.

4-2.6 PA Driver Module. The signal from the Attenuator/Pre-Driver is then applied to the PA Driver module for amplification. The DRIVER GATE signal enables the amplifier when the transmitter/exciter is keyed. A thermal switch opens, removing +28 VDC input voltage to disable the PA Driver in case of an over temperature condition.

4-2.7 Splitter Module. The RF signal from the PA Driver module is then applied to the Splitter module. The Splitter module provides four equal RF outputs to each of the four PA modules.

4-2.8 PA Module. The four PA modules are identical and interchangeable. Each PA module amplifies the signal providing up to 300 Watts of output power to maintain 1000 Watts output. The PAGATE signal enables each amplifier when the transmitter/exciter is keyed. Power variations are compensated for by varying the attenuation of the input drive signal to all four modules.

To prevent overdrive damage to the other PA modules, a low-gain detector circuit in each PA module activates when the gain of the module drops to less than +10 dB. The detector circuit lights the red FLT LED on the front panel of the module. At the same time, a FAULT signal is sent to the MUX circuit on the Filter/Driver board. The MUX circuit then sends the FAULT signal to the microprocessor on the Controller board. In response, the microprocessor, through the Filter/Driver board, causes an additional -6 dB of attenuation to be applied by the Attenuator/Pre-Driver to the RF input of the PA-5050A. When the gain is +10 dB or greater the detector resets, the FLT LED goes off, and normal drive is restored with modulated signals, the FLT LED may momentarily flicker.

A green PWR LED on the front of each module lights when power is applied to the module. If there is an over temperature condition, a thermostat switch in the module opens, and the +28V used to drive the PWR LED is removed. Simultaneously a TEMP sensor signal is sent to the MUX circuit on the Filter/Driver board. The MUX then sends the TEMP signal to the microprocessor on the Controller board. In response, the microprocessor, through the Filter/Driver board, causes an additional 6 dB of attenuation to be applied by the Attenuator/Pre-Driver

to the RF input of the PA-5050A. This reduction of drive to the PA modules causes the temperature to drop. When the PA module cools down sufficiently, the thermostat switch closes. The PWR LED lights, and normal drive is restored.

Each PA module has a VOLTAGE SENSE line that is sent to the individual external power supplies. These signals allow each external power supply to vary the input voltage to compensate for line loss and load variations. If the PS-7130A is used, each input voltage is adjusted based on the VOLTAGE SENSE signal.

4-2.9 Combiner Module. The four outputs of the PA modules are applied to the Combiner module in parallel. The Combiner module combines the signals producing the 1KW final output.

4-2.10 Lowpass Filter Board. The output of the Combiner module is applied to a Lowpass Filter board. One-of-eight lowpass filters is selected by the FL signals from the Controller board. The filter selected depends upon the operating frequency, that is sent to the microprocessor by the exciter/transmitter.

4-2.11 Bi-Directional Coupler. After filtering, the 1 KW signal is applied to a Directional Coupler for sampling. The sampled signal is applied to the Detector circuits in the Filter Driver board. The 1 KW RF signal is then applied to the rear panel on J2 as the final output to the transmitting antenna system.

CHAPTER 5 MAINTENANCE INSTRUCTIONS

Section I. PREVENTIVE MAINTENANCE

- 5-1 INTRODUCTION.** This chapter contains both preventive and corrective operational level maintenance instructions. The information includes cleaning and lubrication, inspection, performance verification, troubleshooting, and module replacement.
- 5-2 CLEANING AND LUBRICATION.** Clean the external surfaces and front panel of the PA-5050A every 2 weeks using a vacuum cleaner or small soft brush to remove any dirt or dust.
- 5-3 INSPECTION.** Perform a visual inspection of the unit quarterly by checking the unit for physical damage.
- 5-4 PERFORMANCE VERIFICATION.** The RF power output of the PA-5050A should be checked quarterly as described in the following paragraphs.

WARNING

Do not key the PA-5050A with the top cover removed. RF burn injury may occur.

1. Remove power to the PA-5050A (PS-7130A S1 to off (down)).

CAUTION

If the equipment is rack mounted, do not slide the equipment drawer out of the rack mount unless absolutely necessary. Damage to the cables connected to the rear panel connectors may occur. If the equipment must be pulled out of the rack mount, do not stress the rear panel cables.

2. Disconnect antenna coax from ANT jack J2, and connect a 1 kW, 50 ohm dummy load and wattmeter.
3. Apply power to the unit. (PS-7130A S1 to on (up))
4. Set the transmitter/exciter frequency to 16.0000 MHz in CW mode.
5. Set transmitter/exciter power to 20 dBm.
6. On the T-4150/80, set PA power to 1 KW.

NOTE

When the 1 KW soft key is pressed the exciter will key and the PA-5050A attenuators will automatically adjust to obtain the 1 KW output power.

7. Momentarily key transmitter/exciter and observe 1000 ± 100 watts on wattmeter.
8. Repeat steps 4. through 7. at other frequencies as required.
9. Remove power to the PA-5050A (PS-7130A S1 to off (down)).
10. Disconnect the 50 ohm dummy load and wattmeter from ANT jack J2 - reconnect antenna coax.
11. Return PA-5050A to normal configuration.

Section II. CORRECTIVE MAINTENANCE

5-5 TROUBLESHOOTING.

5-5.1 Troubleshooting Philosophy. Certain assumptions are made concerning the troubleshooting approach as applied to the unit as follows:

1. All point-to-point wiring is correct. Therefore, no malfunction is the result of a wiring (or cable connector) fault.

NOTE

Suspected failure of cables or connectors require visual inspection and continuity tests using the appropriate diagram. See FO-2 for interconnecting diagram.

2. Malfunctions are non-interactive. Each symptom of a problem is caused by a single malfunction and no additional failures occurred during the troubleshooting process.
3. Multiple faults can be isolated if they are non-interactive.
4. Preventive maintenance has been performed (Section I).

5-5.2 Troubleshooting Procedure. Refer to chapter 4 for the block diagram description. Equipment troubleshooting should be performed in the following order:

1. Fault identification.
2. Initial checks.
3. LED interpretation.
4. Module replacement.
5. Voltage/continuity checks.

Refer to the following paragraphs for details:

5-5.2.1 Fault Identification. A fault is usually indicated by the front panel display, and/or a PWR LED not lit, and/or a FLT LED lit on one of the PA modules.

5-5.2.2 Initial Checks. Before detailed troubleshooting, check that the green PWR LED on the front panel of each PA module is on, the FLT LEDs are off, and power is applied to the equipment (PS-7130A S1 on (up)). If one or more of the PWR lamps are off, and power is applied to the PA-5050A, ensure that +28V DC input voltages are correct. Check all cables and connectors on the rear panel, and check the input RF drive from the exciter.

If one or more PWR LEDs are off, but the master power LED is on, an overheat condition may exist. Unkey the unit and wait five minutes, then try again. If the problem persists, remove and replace the affected module(s).

5-5.2.3 PA Power and Fault LED Interpretation. Each PA module contains a PWR and FLT LED. Table 5-1 lists the conditions of the LEDs, the possible malfunction, and the corrective action.

NOTE

Make sure the exciter is keyed for correct interpretation of LEDs

Table 5-1 Front Panel LED Interpretation.

Master PWR	PWR	FLT	Condition	Corrective Action
ON	ON	OFF	Normal	None
ON	OFF	OFF	1. Overheat 2. Loss of input voltage to module	1. Unkey and wait 5 mins. Check cooling fans Check ambient temperature Replace PA module Replace PA-5050A 2. Check input voltage to module Replace PA module Replace PA-5050A
ON	OFF	ON	Overheat and low RF power out	Unkey and wait 5 mins. Check cooling fans Check ambient temperature Replace PA module Replace PA-5050A
ON	ON	ON	Low RF power out	Check input RF drive from exciter Replace PA module Replace PA-5050A
OFF	OFF	OFF	No input voltages	Check input power supply Replace PA-5050A

NOTES:

If a PWR LED remains off for more than a few seconds, or the FLT LED lights, the fault is usually in the indicated PA module. Remove power from the unit and remove and replace the suspect PA module with one from another slot to confirm the faulty module.

If multiple PWR LEDs are off, excessive temperature may be the problem. Check proper operation of the cooling fans and/or the ambient temperature.

If no power LEDs are off, and no FLT LEDs are lit, check the front panel display for correct VSWR. The problem may be in the antenna system. If the fault cannot be isolated using the above analysis, the fault is probably in the chassis or in a non-monitored function in a PA module. Also check that the transmitter/exciter drive power is sufficient.

5-5.3 Module Replacement.

CAUTION

Turn off power before removing or replacing modules. Equipment may be damaged if modules are removed or replaced with power applied.

To remove and replace a PA module, perform the following procedures:

5-5.3.1 Removal.

1. Turn the knurled knobs on the top and bottom of the PA module counter-clockwise to release the module from the chassis.
2. Slide the module out of the chassis.

5-5.3.2 Replacement.

1. Orient the module to align the connectors on the back of the module with the connectors in the chassis.

CAUTION

Ensure the module connector is aligned correctly with the connector in the chassis or the connectors may be damaged.

2. Push the module firmly in the chassis to seat the connectors.
3. Turn the knurled knobs on the top and bottom of the module clockwise finger tight to secure the module in the chassis.

5-5.3.3 Calibration

The PA-5050A (PA) has a calibration function added for calibrating the PAP1 command after a power amplifier module, driver module, or T-4150/80 has been replaced. The calibration must also be performed after an upload of the software and the first time the system is operated.

The calibration requires an RF input at +24dBm, the low-pass filter selected to match the frequency, and the PA is terminated with a 50Ω resistive load with at least a 1000W rating. The calibration will complete within 5 seconds.

To prepare a controller that has been previously calibrated, the flash must be cleared. There are two methods to accomplish this:

1. Change the power switch to the ON position while pressing the DISPLAY button on the front of the PA. When the display says "PWR OFF TO ABORT", release the button. The display will change to "PRESS TO ERASE". Press the DISPLAY button again to erase the calibration values. When the erase operation is complete the display will show "10000000 -1" for about two seconds. The PA is now ready for calibration. If the power is turned off before the second press, the erase will not occur.
2. Send the PER command through the RS422 bus to the PA. The display will change to "PRESS TO ERASE". Press the DISPLAY button to erase the calibration values. When the erase operation is complete the display will show "10000000 -1" for about two seconds.

There are two methods to calibrate a PA5050A after the calibration values are erased:

1. Attach a T4150/80 to the RF in and control connectors. Set PAPOW to 100 Watts using the softkeys on the T4180/50. Key the transmitter.
2. Attach a signal source at +24dBm to the exciter RF In connector, an RS422 controller to either Remote Control connector, a dummy load capable of sinking at least 1000W for 10 seconds to the ANT connector, and a power meter in series with the dummy load. RS422 commands will be sent using the format shown in table 3-2 in the PA5050A Technical Manual. Set the PA to the frequency of the input signal source using the PAF command. Short pin 1 of the unused Remote Control connector to chassis ground. Send the PAPI command through the RS422 controller. After the power meter reading stabilizes at approximately 120W, remove the ground from pin 1 of the Remote Control connector.
3. Attach a signal source at +24dBm to the exciter RF In connector, an RS422 controller to either Remote Control connector, a dummy load capable of sinking at least 1000W for 10 seconds to the ANT connector, and a power meter in series with the dummy load. RS422 commands will be sent using the format shown in table 3-2 in the PA5050A Technical Manual. Set the PA to the frequency of the input signal source using the PAF command. Send the PT1 command to turn the PA to transmit. Send the PAPI command. After the power meter reading stabilizes at approximately 120W, send the PT0 to unkey the PA.

The alternate receive display on the PA shows ATTEN, which should be a value between 2200 (-22dB) and 1200 (-12 dB) after the calibration is complete.

NOTE

If the amplifier is keyed by means of the PT1 command, the PT1 must be sent before the PAPI.

5-5.4 Voltage/Continuity Checks. If the failed module cannot be isolated using the initial check or LED interpretation, remove and replace the unit. Further isolation should be performed at the factory by checking voltages and continuity of wires in the chassis.



When the top cover is removed, high voltage may be present at the rear panel POWER connector, and the chassis terminal block. Use caution when working in these areas.



Do not key the PA-5050A with the top cover removed. RF burn injury may occur.

1. Using a no. 2 Phillips screwdriver, push down, and turn all captive fasteners on the top cover 1/4 turn counter-clockwise.
2. Remove the top cover.
3. Voltages are checked at various locations in the equipment using a voltmeter (see figures FO-2, FO-3 and FO-4).

4. Some voltages may be checked on the rear panel connectors. Refer to chapter 2 for pin-outs of these connectors. Some voltages may be checked by removing the module where the signal in question terminates, and checking the voltage at the connector in the chassis.

CAUTION

Remove the +28V DC input voltages before performing continuity checks. Damage to the test equipment may occur if continuity checks are performed with input voltages applied to the equipment.

5. Using an ohmmeter, perform continuity checks using FO-2.

CHAPTER 6 PREPARATION FOR RESHIPMENT

6-1 INTRODUCTION. This chapter contains information to prepare the equipment for reshipment including disassembly and removal from the rack mount, packaging, and shipping.

6-2 DISASSEMBLY AND REMOVAL. To disassemble and remove the PA-5050A from the rack mount, perform the following procedures:

1. Remove power from the PA-5050A.
2. Loosen six screws on front panel holding chassis in mounting rack assembly.
3. Slide drawer to the fully extended position.
4. Disconnect all cables from the PA-5050A rear panel.

WARNING

Two-man lift. Unit weighs approx. 75 pounds. Be careful when lifting the unit to avoid injury or damage to the equipment.

CAUTION

Do not support the weight of the unit by the front panel alone. The chassis may bend or warp. Use chassis slides or a suitable support shelf.

5. Remove the PA-5050A from the rack mount.

6-3 PACKAGING.

NOTE

The PA-5050A should be packed in the original shipping container if available.

To package the equipment for reshipment perform the following steps:

1. Ensure that there is sufficient foam packing material in the shipping container to protect the unit from any hard impact.
2. Cover the unit with foam or bubble-type packing material.
3. Place the unit in the center of the shipping container.
4. If using a cardboard packing carton, securely tape the seams of the carton's top cover, bottom cover, and side flaps with reinforced packing tape.
5. Attach labels or stamp in indelible ink the word FRAGILE on the top, bottom, and all sides of the container.

6-4 SHIPPING.

CAUTION

Unit contains parts and assemblies sensitive to damage by electrostatic discharge (ESD). Do not ship or store near strong electrostatic, electromagnetic, magnetic or radioactive fields.

There are no special shipping requirements for the unit. Commercial or military surface or air shipping services may be used.

CHAPTER 7 STORAGE

- 7-1 INTRODUCTION.** This chapter contains information for storage of the equipment including environmental conditions and any special preservation requirements.
- 7-2 STORAGE ENVIRONMENT.** The PA-5050A should be stored indoors in the original shipping container (or similar container) as described in Chapter 6. The environment should be dry with a temperature range between -40 and +75 °C.

CAUTION

Unit contains parts and assemblies sensitive to damage by electrostatic discharge (ESD). Do not ship or store near strong electrostatic, electromagnetic, magnetic or radioactive fields.

- 7-3 PRESERVATION.** There are no special coverings or preservation materials required to store the PA-5050A.

CHAPTER 8 PARTS LIST

8-1 INTRODUCTION. This chapter contains the parts list for replaceable parts at the operational maintenance level.

8-2 REPLACEABLE PARTS LISTING. Table 8-1 lists the replaceable parts for the unit. (See figure FO-4 for locations.)

Table 8-1 Replaceable Parts List.

Qty	Description	Part Number	Mfr ¹
4	Power Amplifier Module	2241-1111-1	CCI

¹Cubic Communications Inc.

APPENDIX A REMOTE CONTROL CABLE

A-1 INTRODUCTION. This appendix contains a description of the remote control cable connecting the PA-5050A to the T-4150/80 exciter.

A-2 DRAWING. Figure A-1 shows the schematic of the remote control cable CCI P/N 2241-5023-X.

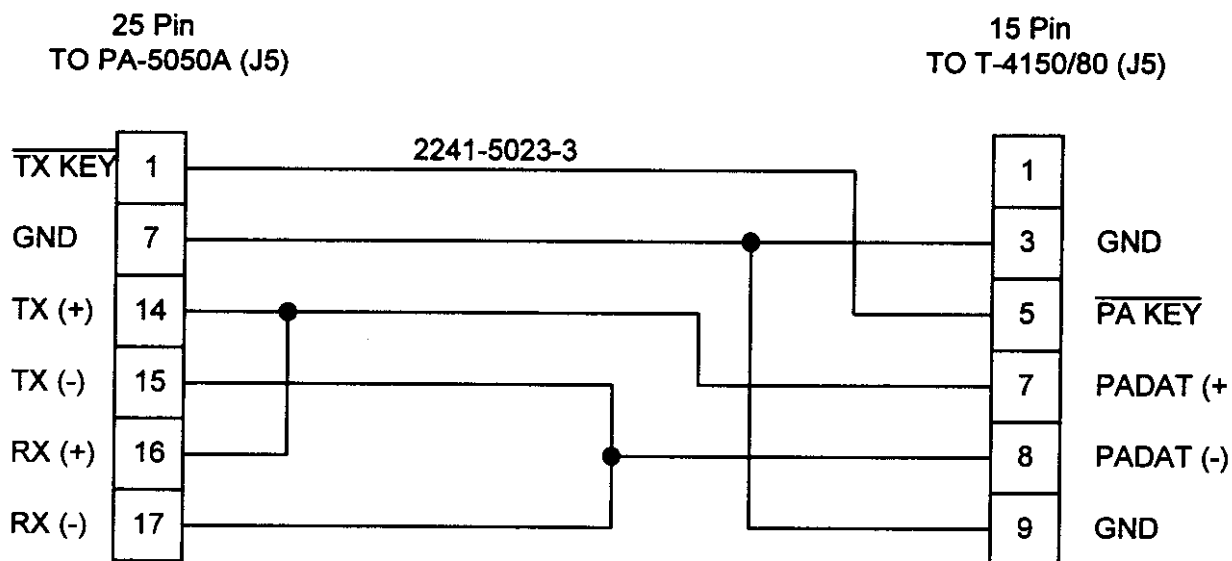
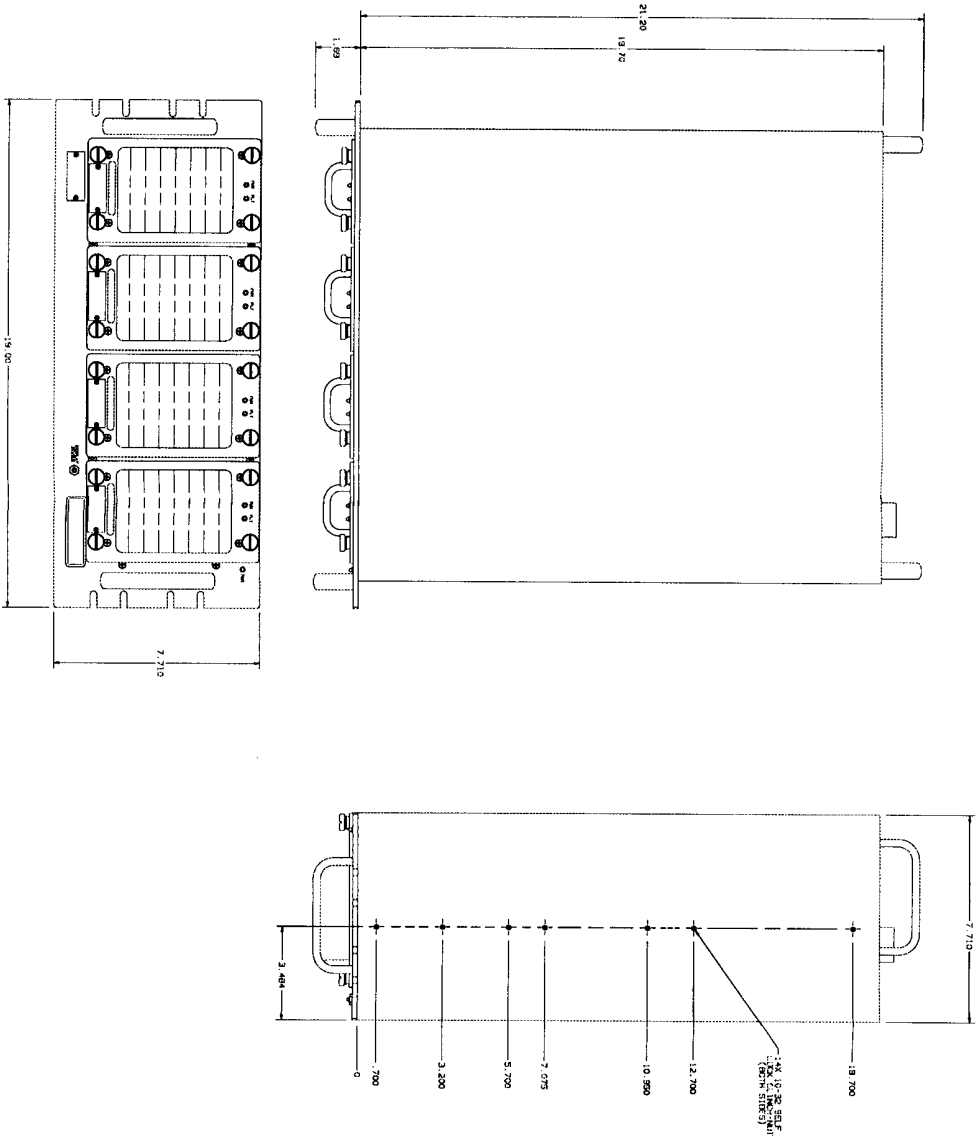
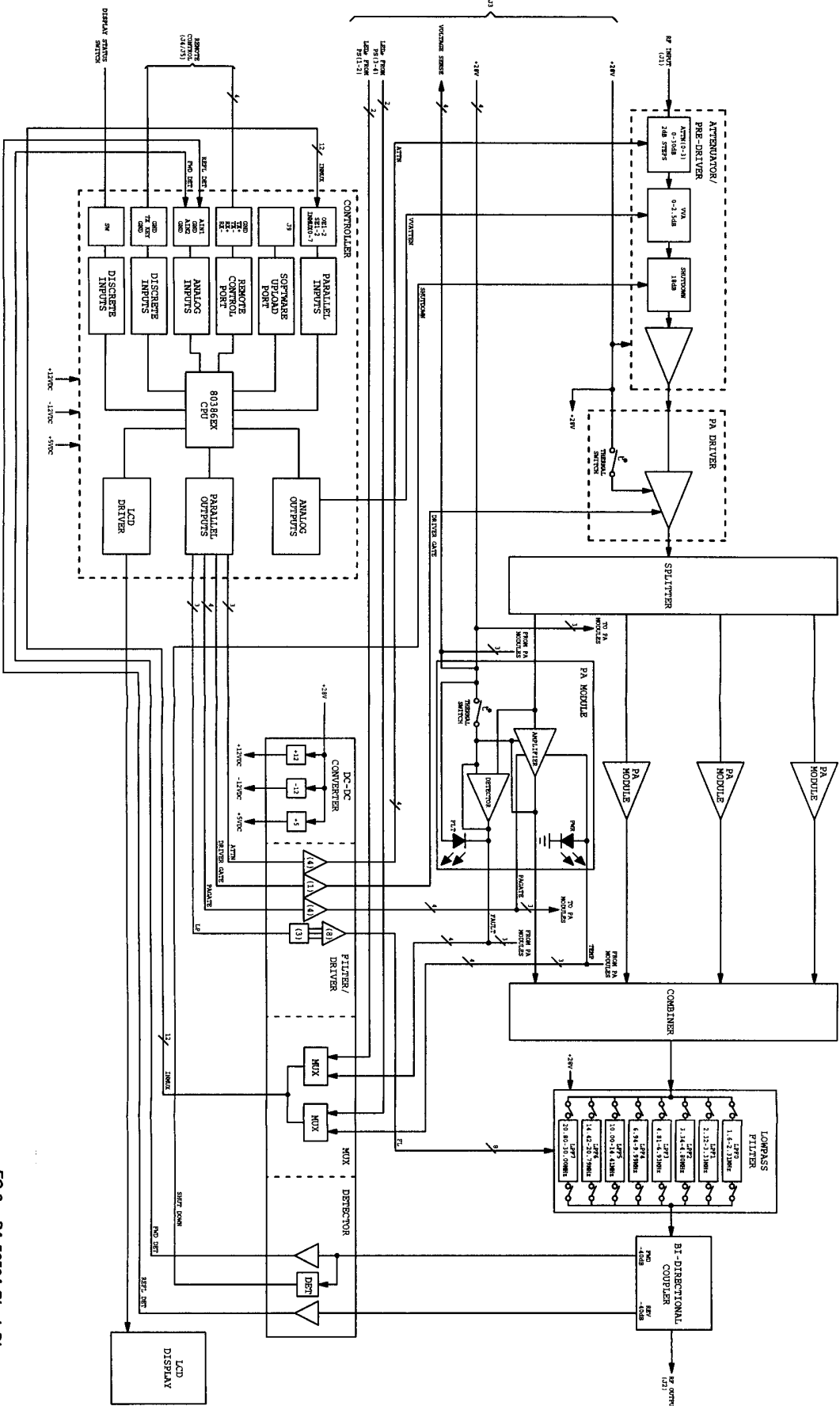

Figure A-1 Schematic, Remote Control Cable 2241-5023-X.



FO-1. PA-5050A Outline and Mounting Drawing
 FP-1/(FP-2 blank)



FO-2. PA-5050A Block Diagram.

FP-3/(FP-4 blank)

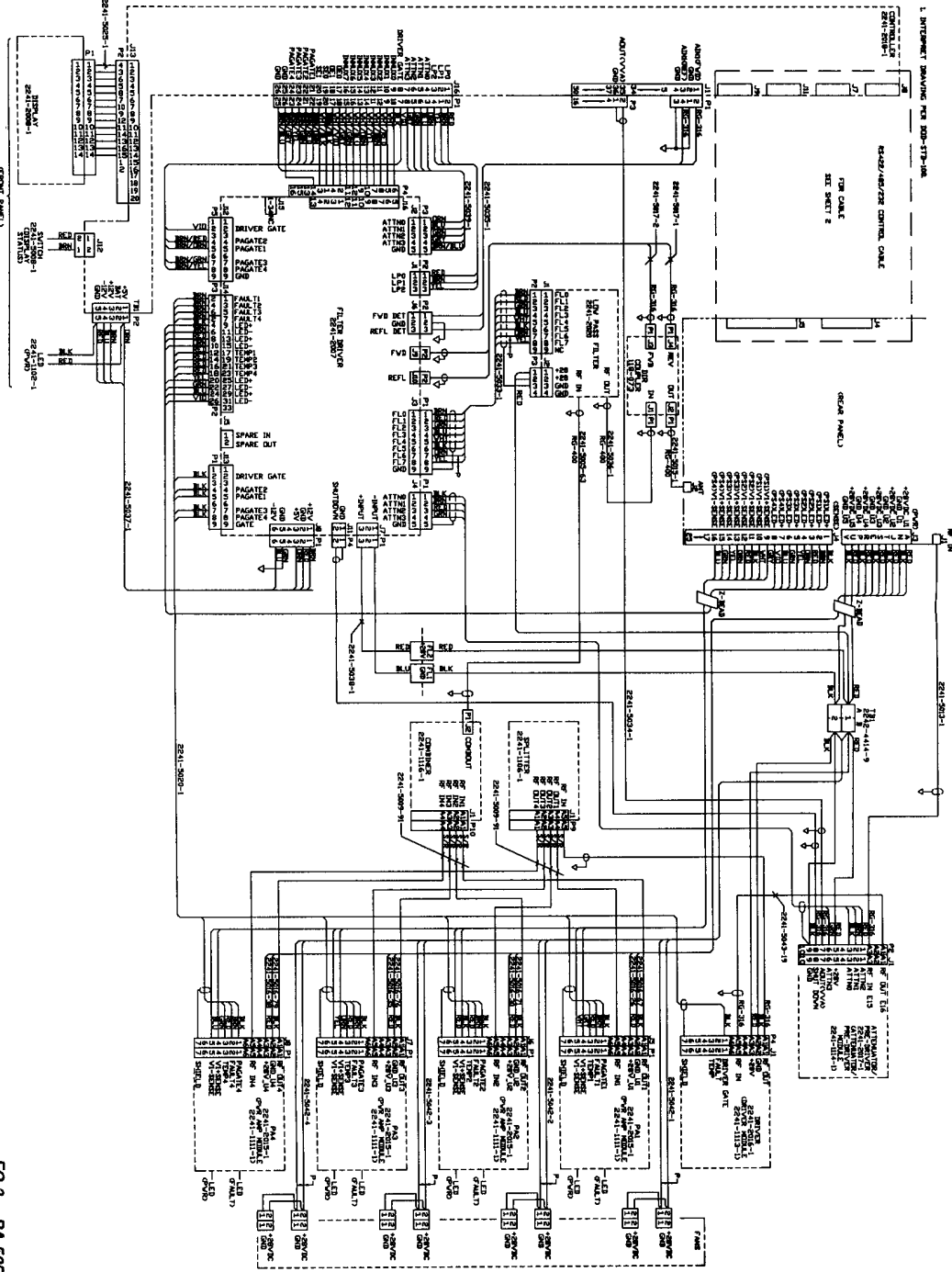

FO-3. PA-5050A Interconnect Diagram.
 (Sheet 1 of 2)

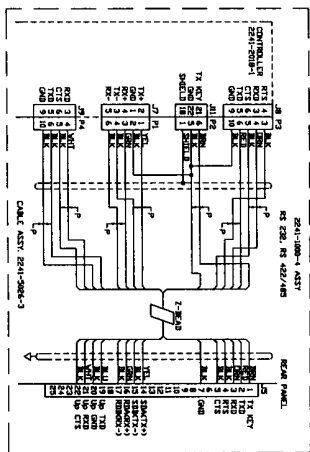
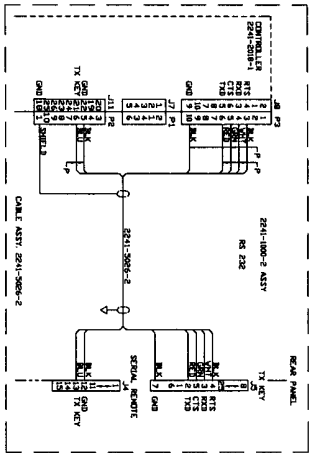
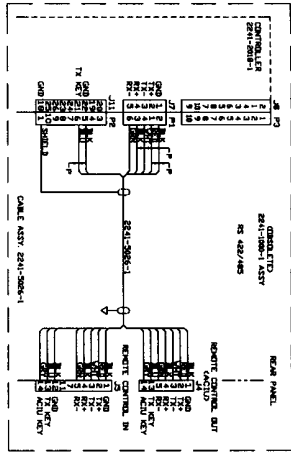

FO-3. PA-5050A Interconnect Diagram.
 Cable Drawing (Sheet 2 of 2)

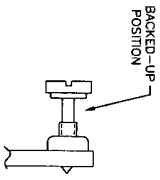
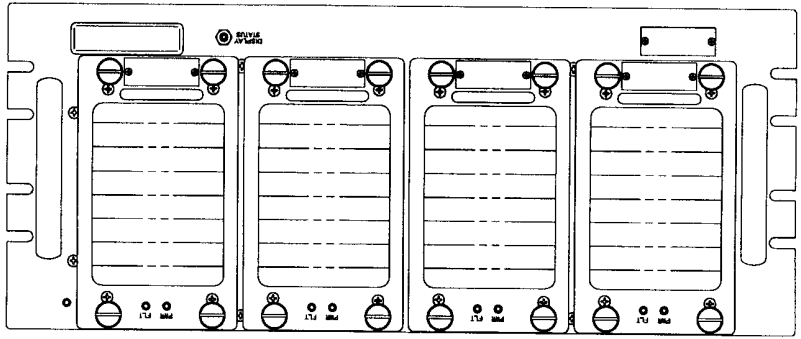

VIEW A
 PLACE THUMB SCREWS ON POWER AMP MODULE IN THE
 BACKED-UP POSITION SHOWN PRIOR TO INSTALLATION IN CHASSIS.

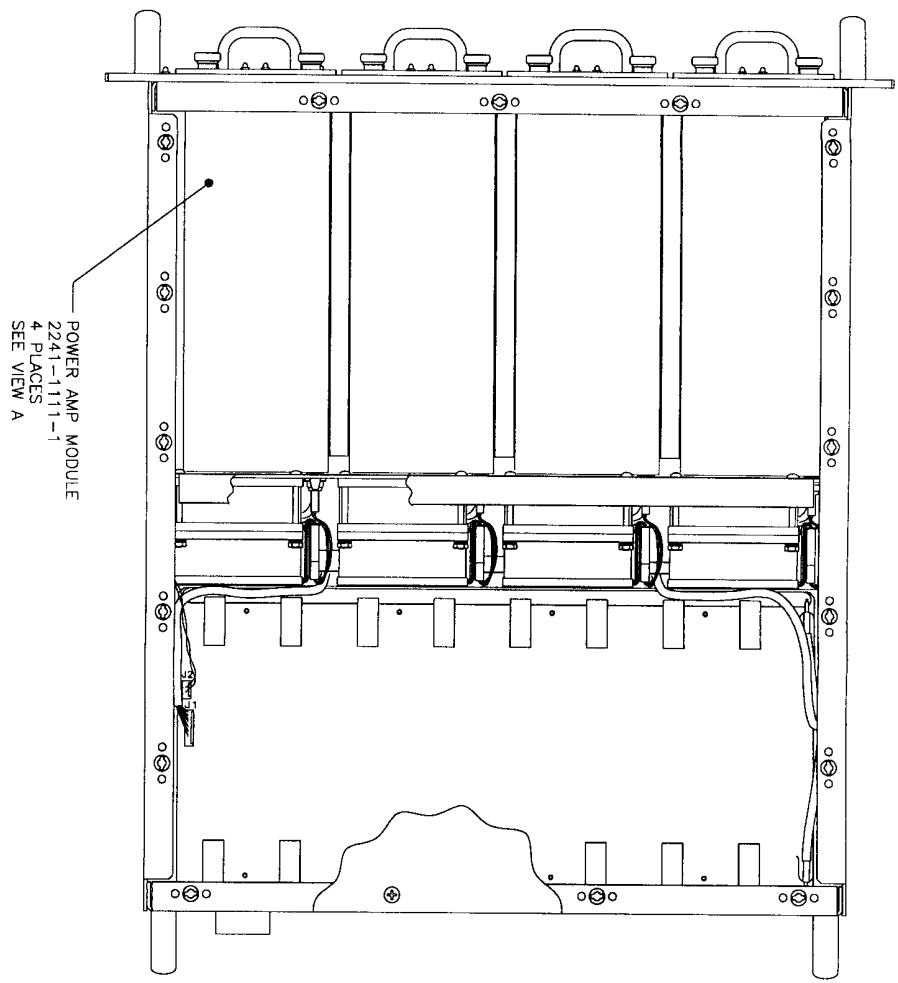

FO-4. PA-5050A Replaceable Parts Locator Diagram.

FP-7/(FP-8 blank)