



H-30 MODEL SERIES

OWNERS GUIDE

NOTICE: This system is intended for use on potable water supplies or disinfected water containing cysts. Do not use where water is microbiologically unsafe or with water of unknown quality. If bacterial contamination is present, a recognized method of water disinfection is required.

Check with your public works department for applicable local plumbing and sanitation codes. Follow your local codes if they differ from the standards used in this manual.

Operational, maintenance and replacement requirements are essential for this product to perform properly. The Good Water Machine[™] contains replaceable particulate and activated carbon filters. It also includes a replaceable reverse osmosis membrane filter which is critical for the effective reduction of Total Dissolved Solids. The filtered water should be tested periodically to verify that the system is performing properly.

CULLIGAN INTERNATIONAL COMPANY
One Culligan Parkway
Northbrook, Illinois USA 60062-6209
847/205-6000
www.culligan.com

Culligan®
GOOD WATER MACHINE™
DRINKING WATER SYSTEM

Table of Contents

Safety/Warnings	i
System Specifications	1
Introduction	
About Your System	2
Component Description	2
Certified Performance	3
How to Use Your System	4
Performance Check	4
Installation	
Application Guidelines	5
Servicing Your System	
Service Schedule	7
Filter Replacement	7
Parts List	11
Service Log	12
Warranty	13

SYSTEM SPECIFICATIONS

System Flow Sequence	Particle/Activated Carbon Filter(s), Reverse Osmosis Membrane Filter, Storage Tank, Polishing Filter, Dispensing Faucet
Particle/Activated Carbon Filter	
H-30S-R	Filter cloth wrapped activated carbon block
Particle Filter, H-30PRV-C	5 Micron Spun Polypropylene
Activated Carbon Filter, H-30PRV-C ..	Cullar® G Activated Carbon
Reverse Osmosis Membrane Filter	Culligan® Aqua-Clear® Thin Film Composite
Production Rate ¹ - H-30 Models	30 gpd (114 L/day)
Ratio of Product to Flush Flow ²	1:3 - 1:5
Polishing Filter	Cullar G Activated Carbon
Dispensing Faucet	Culligan Aqua-Clear Faucet: Rotary Operation, Stainless Steel and Resin Flow Passages, with Built-in Siphon Break
Colors	Polished Chrome, White
Storage Capacity - Standard Tank	2 gallons
- Medium Tank	3 gallons
- Large Tank	9 gallons
Dimensions - Filter Assembly	
(H-30S-R)	7"W x 4.3"D x 16.3"H
(H-30PRV-C)	15.8"W x 4.3"D x 16.3" H
- Storage Tank	9" Diameter x 14" H
- Medium	11"Diameter x 14" H
- Large	15.5" Diameter x 24" H

¹Rating at 50 psi, 77°F, 500 mg/L TDS Influent, Without Storage Tank

²May vary with pressure.

INTRODUCTION

Thank you for choosing a Culligan® Good Water Machine™ drinking water system. Your new system is designed to bring you years of healthful, deliciously crystal-clear Culligan® water. With its special faucet installed on your sink, it's like getting bottled water straight from your kitchen tap.

ABOUT YOUR SYSTEM

The reverse osmosis method of water treatment has long been regarded as one of the most efficient and effective ways to reduce impurities. It's the technology we've used to build your new Culligan Good Water Machine. In addition, we've incorporated activated carbon and fine particle filtration to bring you one of the most effective systems available today.

GOOD WATER MACHINE SYSTEM COMPONENTS

Refer to Figure 1, page 6

Particle Filter (Model H-30PRV-C)

The particle filter screens out dirt, sand, rust, and other microscopic particles 15 times smaller than a grain of sand.

Activated Carbon Filter (Model H-30PRV-C)

The activated carbon filter gets rid of bad tastes and odors, including chlorine. If present in your untreated water supply.

Particle/Activated Carbon Filter (Model H-30S-R)

The particle/activated carbon filter combines the filtration capabilities of separate particle and activated carbon filters into one space efficient package.

Reverse Osmosis Membrane Filter

The reverse osmosis (RO) membrane filter squeezes out dissolved substances, including lead, asbestos, and many others. These substances may not be in your water. See Performance Data Sheet for list of substances and removal percentages.

Storage Tank

The storage tank holds up to 2 gallons of triple-filtered Culligan® water under pressure for rapid delivery. Optional three and nine-gallon tanks are available.

Polishing Filter

The Good Water Machine™ includes a second activated carbon filter as added assurance that your water will be crystal clear.

Faucet

The special drinking water faucet mounts conveniently on your kitchen sink. A simple twist of the handle is all it takes to enjoy refreshing Culligan drinking water.

CERTIFIED PERFORMANCE

The Culligan® Good Water Machine Model H-30S-R and H-30PRV-C Drinking Water Systems have been tested and certified to ANSI/NSF International Standard 58 for effective reduction of TDS, Asbestos, Barium, Cadmium, Hexavalent and Trivalent Chromium, Copper, Cysts, Fluoride, Lead, Mercury, Radium 226/228, and Selenium.



Average removal percentages are as follows:

Asbestos	99.6%	Fluoride	96.4%
Barium	90.1%	Lead	98.6%
Cadmium	98.9%	Mercury	83.1%
Chromium III	97.9%	Radium 226/228*	80.0%
Chromium VI	82.6%	Selenium	94.5%
Copper	98.9%	TDS/Sodium Chloride	91.3%
Cysts (including Cryptosporidium, Giardia Lambliia and Entamoeba Histolytica)	99.99%		

*Minimum removal based on approved testing methods with Barium as surrogate.

The substances removed by this system are not necessarily in your untreated water. See Performance Data Sheet for exact percentages of contaminant removal.

HOW TO USE YOUR SYSTEM

With the Good Water Machine™, you'll get a continuous supply of clear, refreshing water for drinking and cooking. But Culligan improves a lot more than just water. Crystal clear Culligan® water is ideal for:

- coffee
- tea
- soup
- juice
- everything you make with water
- recipes
- baby formula
- houseplants
- pets
- pasta
- ice cubes
- steam irons
- drink mixes

PERFORMANCE CHECK

To check the performance of your Good Water Machine, it is necessary to measure the total dissolved solids (TDS) level of the filtered water. This simple test can be done quickly by your dealer.

The Good Water Sentry™ Water Quality Monitor is another way to keep track of your system's performance. This optional accessory checks your drinking water each time you use the special faucet, and signals when the membrane filter may need to be replaced.

If the water quality of your system seems to have declined, drain the storage tank and allow the system to refill. If the problem persists, call your Culligan Man for service.

INSTALLATION

This Owner's Guide provides visual assembly reference only. Since specialized skills are required in the assembly of the drinking water system, we recommend that you contact your local independently operated Culligan dealer to complete this installation.

APPLICATION GUIDELINES

The Good Water Machine™ is designed for use on potable water supplies meeting the guidelines outlined in Table 1. The system should be installed on your home's cold water line. The flushing stream should discharge through an approved siphon break as illustrated in Figure 1. Installation of this system must comply with state and local laws and regulations.

TABLE 1

Influent Water Characteristic	
Pressure	40 - 120 psi (280 - 827 kPa)
Temperature	33 - 100°F (1 - 38°C)
Total Dissolved Solids (TDS) ¹	0 - 4000 ppm (0 - 4000 mg/L)
pH	5 - 10
Chlorine ²	0 - 3 ppm (0 - 3 mg/L)
Chloramine	0 - 3 ppm (0 - 3 mg/L)
Turbidity	0 - 10 NTU
Iron	0 - 1 ppm (0 - 1 mg/L)
Bacterial Quality	Potable

¹ See the Technical Manual for all applications where TDS exceeds 1000 ppm (1000 mg/L). A booster pump is strongly recommended.

² The reverse osmosis membrane filter used in this system may be damaged by chlorine. This system includes activated carbon which protects this element by reducing chlorine. Influent chlorine should not exceed 3 mg/L.

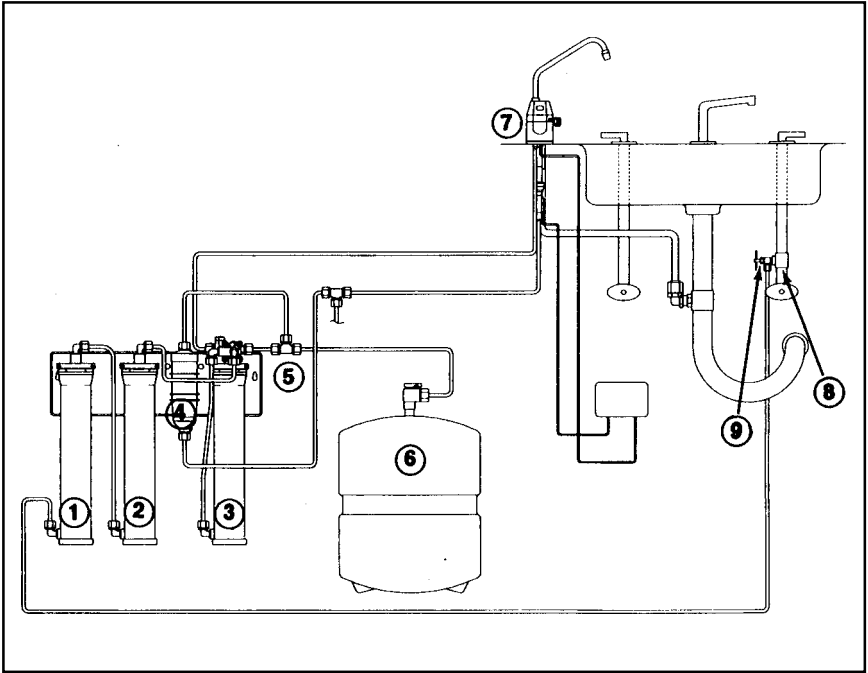

Fig. 1

1. Particle Filter*
2. Activated Carbon Filter*
3. Reverse Osmosis Membrane Filter
4. Polishing Filter
5. Tubing Tee
6. Storage Tank
7. Faucet
8. Cold Water Line
9. Water Shutoff

*Combined Particulate/Activated Carbon Filter on Model H-30S-R

SERVICING YOUR SYSTEM

SERVICE SCHEDULE

When properly maintained, your Good Water Machine™ will give you years of dependable service. Use the following as a guide to get the most out of your system. Service frequency may vary depending on your local water conditions. High sediment, chlorine, turbidity, or hardness levels may require more frequent service. Refer to Figures 4 & 5, on page 9.

At Least Once Per Year

Replace:

- Particle/Activated Carbon Filter(s)
- Polishing Filter

Check:

- RO Membrane Filter
 - TDS Reduction Performance
 - Flow Rates
- Capillary Assembly

Sanitize the System.

Use the convenient chart inside the back cover of this booklet to keep track of your system's maintenance.

FILTER REPLACEMENT

Culligan recommends that you have your Good Water Machine serviced by your local Culligan Man. You can rely on his or her experience and expertise to keep your system in top operating condition.

If you wish to service your system, the filters are available from your Culligan dealer. See the Parts List at the end of this section for replacement numbers.

Cartridge Conditioning

The activated carbon, reverse osmosis, and polishing filter cartridges must be conditioned as follows prior to installation into the Good Water Machine. Your Culligan Man can do these important procedures at the time of purchase.

Activated Carbon Cartridge - 5 gallon flush to remove carbon dust

RO Membrane Filter - 6 hour flush to remove preservative solution

Polishing Filter - 2 gallon flush to remove carbon dust

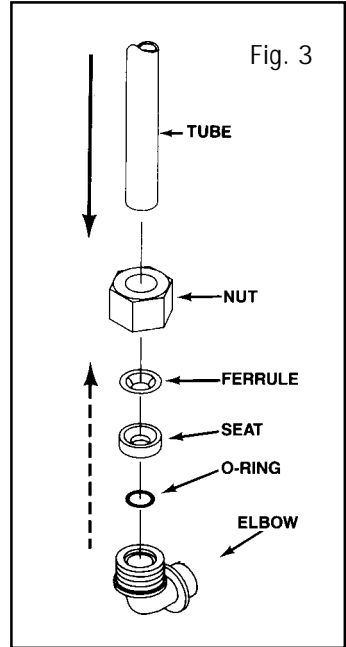
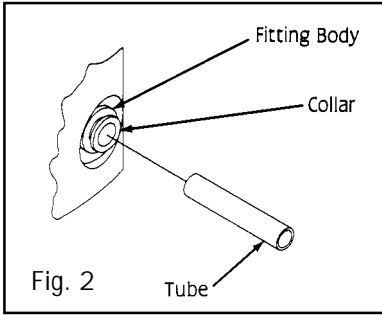

Tubing Connectors

The Good Water Machine™ system features two simple types of tubing connectors. Tubing can be connected easily as follows:

Push-in type (Fig. 2)

To connect, lubricate the tubing end with water and push the tubing into the connector until it bottoms out. Be sure the tubing is smooth and free of scratches, otherwise a leak may result.

To disconnect, hold the collar against the fitting body and pull the tube from the fitting.

Threaded type (Fig. 3)

To connect, assemble the fitting parts onto the fitting, leave the nut loose, and push the tubing firmly into the fitting until it bottoms out. Hand-tighten the nut.

To disconnect, loosen the nut and pull the tubing from the fitting.

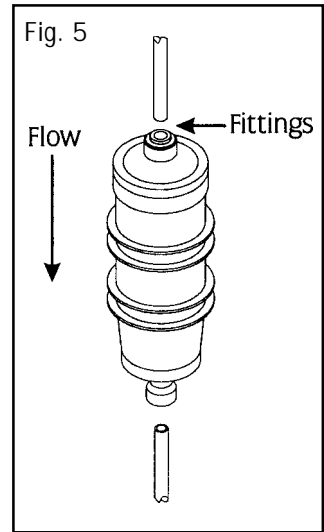
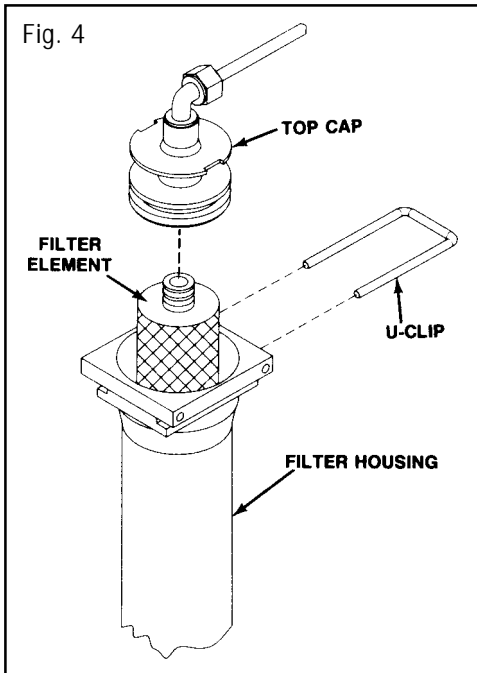

Filter Replacement and Sanitizing Procedure

Use the following procedure and reference in Fig. 1, 4 & 5 when servicing the Good Water Machine™.

NOTICE: *You may want to fill a pitcher with drinking water before beginning service as it will take several hours for the system to refill after servicing.*

The Good Water Machine may be sanitized with either 5-1/4% liquid chlorine bleach or a fresh bottle of consumer grade hydrogen peroxide.

NOTICE: *The reverse osmosis membrane filter used in this system may be severely damaged by chlorine. The membrane filter must be removed from the system if chlorine bleach is to be used for sanitizing.*

NOTICE: *Hydrogen peroxide should not be used if iron is present in the supply water as the RO membrane filter may be damaged.*

Cleanliness is essential in the filter replacement procedure. Be sure to wash your hands thoroughly before handling filters. The use of surgical gloves is strongly recommended.

1. Locate the system's supply valve and turn off the system's water supply.
2. Open the dispenser faucet and drain the storage tank.
3. Place the filter assembly in a dish pan or similar container to catch any dripping water.
4. Relieve the pressure in the system by loosening the threaded tubing connector at the bottom of the RO membrane filter housing. Retighten the fitting.
5. Pull the u-clip from the top of the particle prefilter housing. (Fig. 4)
6. Push the top cap into the housing to free the o-ring seal, then pull the top cap from the housing.
7. Remove the particle prefilter element from the housing and discard.
8. Clean the inside of the housing and top cap.
9. Lubricate the new particle prefilter cartridge o-ring with water and insert the new filter cartridge into the top cap. Note: If Model H-30S-R, *do not* install particulate/carbon filter at this time.
10. Pour two tablespoons liquid chlorine bleach or 3 ounces hydrogen peroxide into the particle prefilter housing.
11. Assemble the housing, the top cap and the u-clip.
12. Repeat steps 5-8 and remove the activated carbon cartridge and, if using chlorine bleach, the RO membrane filter.
NOTICE: If the RO membrane filter is to be reused, place it in a new plastic bag to keep it clean.
13. Assemble the empty housings and replace the u-clips. Make sure all tubing is connected properly.
14. Turn on the supply valve and allow the system to fill with water. Once water begins to drip or flow from the faucet, close the faucet and allow the tank to fill.
15. Turn off the supply valve and allow the system to sit for ten minutes.
16. Open the dispenser faucet and drain the storage tank.
17. Repeat steps 4, 5, 6, 9, and 11 for replacement of the activated carbon, particulate/activated carbon (Model H-30S-R) and RO membrane filter cartridges.
18. If using hydrogen peroxide, disconnect the storage tank tube from the tubing tee. With an eyedropper or similar device, inject one tablespoon of hydrogen peroxide into the tube and reconnect it to the tee.
19. Note the direction of flow and disconnect the tubing from the polishing filter. Fig. 5.
20. Note the direction of flow and install the new polishing filter.
21. Replace the filter assembly into its mounting location.
22. Repeat step 14.
23. After the storage tank has filled (3-4 hours), open the faucet and drain the storage tank to flush the new polishing filter and any remaining sanitizing solution from the system.
24. Allow the system to refill. Your system is now ready for use.
25. Record your service on the chart at the end of this booklet.

PARTS LIST

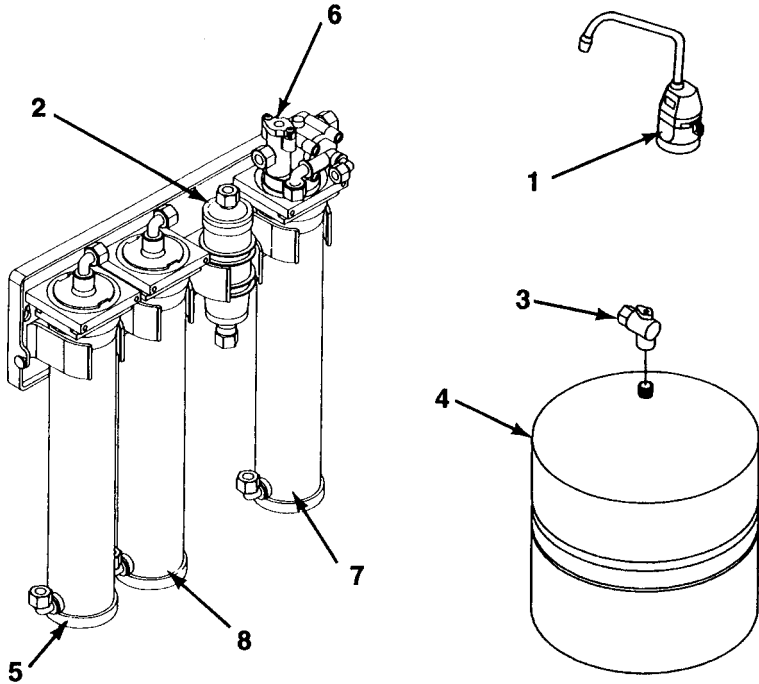

Item	Description	Part Number
1	Faucet - Chrome - White	01-0004-42 01-0022-53
2	Polishing Filter	01-0000-79
3	Plastic Ball Valve	01-0027-85
4	Storage Tank - Std. - Medium - Large	01-0050-95 01-0047-76 01-0047-65
5	Particle Filter Element (Model H-30 PRV-C) Particulate/Activated Carbon Element (Model H-30S-R)	00-4015-38 01-0008-27
6	Capillary Assembly	01-0090-27
7	Reverse Osmosis Membrane Element H-30	01-0074-02
8	Activated Carbon Element (Model H-30 PRV-C)	01-0000-78
*	Icemaker Tee - 1/4 x 1/4 x 1/4	01-0024-66
*	Tubing, Blue - 1/4" O.D.	00-4021-84
*	Good Water Sentry™ Monitor	01-0039-45
*	Aqua-Clear® Booster Pump	01-0093-34

* Not Illustrated

CULLIGAN LIMITED WARRANTY

GOOD WATER MACHINE™ H-30 MODEL SERIES

You have just purchased one of the finest drinking water systems made. As an expression of our confidence in Culligan products, your drinking water system is warranted to the original end-user, when installed in accordance with Culligan International Company specifications, against defects in material and workmanship from the date of original installation, as follows:

**For a period of
FIVE YEARS**

**The entire reverse osmosis water conditioning unit,
EXCLUDING THE EXPENDABLE FILTER CARTRIDGES
AND REVERSE OSMOSIS MEMBRANE FILTER USED
IN THIS UNIT.**

For a period of ONE YEAR

The Culligan brand reverse osmosis membrane filter.

If a part described above is found defective within the specified period, you should notify your independently operated Culligan dealer and arrange a time during normal business hours for the dealer to inspect the drinking water system on your premises. Any part found defective within the terms of this warranty will be repaired or replaced by the dealer. You pay only freight from our factory and local dealer charges.

Damage caused by accident, fire, flood, freezing, Act of God, misuse, misapplication, neglect, alteration, installation or operation contrary to our printed instructions, or by the use of accessories or components which do not meet Culligan specifications, is not covered by this warranty.

Our product performance specifications are furnished with each drinking water system. TO THE EXTENT PERMITTED BY LAW, CULLIGAN DISCLAIMS ALL IMPLIED WARRANTIES INCLUDING, WITHOUT LIMITATION, WARRANTIES OF MERCHANTABILITY AND FITNESS FOR PARTICULAR PURPOSE; TO THE EXTENT REQUIRED BY LAW, ANY SUCH IMPLIED WARRANTIES ARE LIMITED IN DURATION TO THE ONE-YEAR PERIOD SPECIFIED ABOVE FOR THE PARTS DESCRIBED IN THIS LIMITED WARRANTY. As manufacturer, we do not know the characteristics of your water supply or the purpose for which you are purchasing a drinking water system. Please understand that the quality of water supplies may vary seasonally or over a period of time, and that your water usage rate may vary as well. Water characteristics can also change considerably if your drinking water system is moved to a new location. For these reasons, we assume no liability for the determination of the proper equipment necessary to meet your requirements, and we do not authorize others to assume such obligations for us. Further, we assume no liability and extend no warranties, express or implied, for the use of this product on a non-potable water source. OUR OBLIGATIONS UNDER THIS WARRANTY ARE LIMITED TO THE REPAIR OR REPLACEMENT OF THE FAILED PARTS OF THE DRINKING WATER SYSTEM, AND WE ASSUME NO LIABILITY WHATSOEVER FOR DIRECT, INCIDENTAL, CONSEQUENTIAL, SPECIAL, GENERAL, OR OTHER DAMAGES, WHETHER FROM CORROSION OR OTHER CAUSES.

CONSUMERS:

Some states do not allow limitations on how long an implied warranty lasts, so the above limitation may not apply to you. Similarly, some states do not allow the exclusion of incidental or consequential damages, so the above limitation or exclusion may not apply to you. This warranty gives you specific legal rights, and you may also have other rights which vary from state to state. Consult your telephone directory for your local independently-operated Culligan dealer, or write Culligan International Company, for warranty and service information.

CULLIGAN INTERNATIONAL COMPANY
One Culligan Parkway
Northbrook, Illinois 60062