

PBT325 Stereo Bluetooth Headset

1. About PBT325

The Bluetooth headset PBT325 allows you the freedom to make and receive calls while on the move or in the office, after you connect the headset to a compatible phone that supports Bluetooth wireless technology. PBT325 is a stylish design with metal casing and only 5.5mm thickness. It applies dual microphones combined with latest CVC software to do echo and noise cancellation. With additional earphone, you can also enjoy music transmitted by the mobile via Bluetooth. Read this user guide carefully before using the headset. Read also the user guide for your phone, which provides important safety and maintenance information.

2. Bluetooth wireless technology

Bluetooth wireless technology makes it possible to connect compatible communication devices without using cables. A Bluetooth connection does not require that the phone and the headset be in line of sight, but both devices should be within 10 meters (30feet) of each other. Connections can be subject to interference from obstructions, such as walls or other electronic devices.

PBT325 is compliant with Bluetooth Specification v2.1 supporting Headset profiles 1.1 and Hands-Free Profiles 1.5.

There may be restrictions on using Bluetooth technology in some locations .Check with your local authorities or service provider.

3. Overview

The headset contains the following parts as shown in the figure:

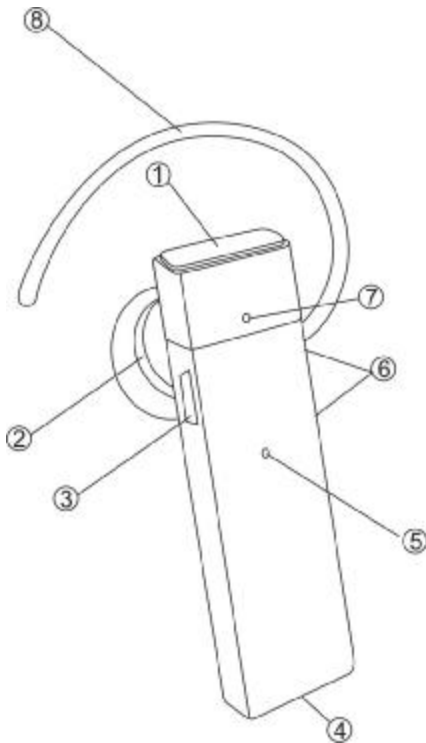

- (1) Answer/end key
- (2) Earphone
- (3) Charging connector & earphone jack.
- (4) Microphone 1
- (5) Microphone 2
- (6) Volume + and -
- (7) LED Indicator
- (8) Ear hook

Before you start using the headset, you must charge the battery and pair the headset with a compatible phone.

4. Charging the headset

This device has an internal, rechargeable battery which must be fully charged before used for the first time. It takes you about 3 hours to charge the battery full for the first time. During charging, the indicator shows a steady blue. When the battery is fully charged, the blue light will turn off. For the later on charging, it takes about 90 minutes.

You can charge the headset either by using the USB charging cable or the car charger depending on the package accessories available. Please check your package for details. PBT325 is intended for use with the chargers that is included in the package.

I If your package has a USB charging cable included

Plug the charger lead of USB charging cable into the charging port of your Bluetooth headset. And then plug the other end of the USB charging cable into the computer's USB port. When charging is complete, remove the USB charging cable and remove the charger lead from your headset (Please refer to Fig.1, Fig.2.)

I If your package has a car charger included

Plug the car charger into the cigarette lighter socket. And then plug the charger lead into the charging port of the Bluetooth headset. When charging is complete, remove the car charger and remove the charger lead from your headset (Please refer to Fig.3.)

I If your package has a travel charger included

Plug the travel charger into 110-240V wall socket. And then plug the charge lead into the charging port on the Bluetooth headset for charging. When charging is complete, remove the travel charger and remove the charger lead from your headset.

The fully charged battery has power for up to 4.5 hours of talking time or up to 90 hours of standby time. However, the talk and standby times may vary when used with different mobile phones, products that use a Bluetooth connection, usage settings, usage styles, and environments.

When the battery is running out of power, the blue indicator light starts to flash 3 times every 30 seconds. This indicates that the headset needs to be charged as soon as possible.

5. Switch on or off the headset

To switch on, when PBT325 is in off state, press and hold the answer/end key for 4 seconds until the blue indicator light turns on and keeps on for 3 seconds.

To switch off, when PBT325 is in on state, press and hold the answer/end key for 4 seconds until the blue indicator light flashes for 5 times.

6. Pair the headset with a compatible phone

Pairing is the process of establishing encrypted link between PBT325 and Bluetooth devices.

Step-1 The headset must be powered off before you begin to initiate the pairing.

Step-2 press and hold the answer/end key for 7 second until the blue light turns on and keeps on. The headset is now in pairing mode.

Step-3 Activate the Bluetooth feature on the phone, and set the phone to search for Bluetooth devices. Check the user guide of your phone for instructions.

Step-4 Select the headset (PBT325) from the list of found devices.

Step-5 When asked the PIN code, please enter "0000" to pair and connect the headset to your phone.

In some phones you may need to make the connection separately after pairing. See the user guide of your phone for details.

If the pairing is successful, the headset enters idle state and blue light will flash 1 time every 5 seconds. The headset's name appears in the phone menu where you can view the currently paired Bluetooth devices.

You only need to pair the headset with your phone once.

Troubleshooting



If you cannot connect the headset to your phone, do as follows:

- Ensure that the headset is charged, switched on, paired with and connected to your phone.
- Ensure that the Bluetooth feature is activated on your phone.
- Check that the headset is within 10 meter(30 feet) of your phone and that there are no obstructions between the headset and the phone, such as walls or other electronic devices.

If no pairing is made over a period of time, the headset will retreat pairing mode. You have to turn off the headset and operate again.

7. Basic use

7.1 Make a call

To make a call, use your phone in the normal way when the headset is connected to your phone. The sound will be transmitted to the headset automatically.

7.2 Answer a call

When there is incoming call, press the answer/end key, or use the phone keys to answer the call.

7.3 End a call

After finishing the call, press the answer/end key, or use the phone keys to end the call.

7.4 Refuse a call

When there is incoming call, press and hold answer/end button for 4 seconds until you can hear beep sound from the headset.

7.5 Voice dialing (dialing a number by saying a name)

It is possible to make a call directly from the headset using voice recognition. To use this voice dialing function, your mobile phone must provide this option and corresponding voice samples must have been recorded.

Step-1 Enable voice recognition function of your mobile and set the mobile to handsfree state.

Step-2 When no call is in progress, press and hold the answer/end button for 4 seconds until you can hear beep sound from the headset.

Step-3 Speak out the name of the person you wish to call loudly.

7.6 Redial

Double press answer/end button and you can hear beep sound from the headset. Release the button and the headset will dial the last dialed telephone number.

7.7 Listening to music

Plug additional earphone to the charging & earphone jack, you can use PBT325 to enjoy the streaming stereo music transmitted from you compatible mobile with Bluetooth function. The mobile needs to

support Bluetooth A2DP (Advanced Audio Distribution Profile).

and AVRCP (Audio Video Remote Control Profile).

When there is incoming call, you will hear beep sound from the headset. The music will pause when you answer the call. After u finished the call, the music will follow to be streamed in a few seconds. Some mobile phones do not release the connection switch function to the headset, which will cause the headset to fail to switch the Bluetooth connection between music and call

7.8 Play/Pause music

In idle state, press answer/end button one time to play or pause music.

7.9 Adjust the earphone volume

Press the volume + key to increase or - to decrease the volume during a call or listening to music.

7.10 Previous/Next song

When playing music, press and hold volume + to play previous song or volume– button to play next song

7.11 Switch the call between mobile and headset

In call state, press and hold volume + and volume – button at the same time for about 4 seconds until there is beep sound from headset. The call will be switched from headset to mobile or vice versa.

8. LED Indication

Headset status	LED Indication
In idle state after paired	flashes 1 time every 5 seconds
In coming call	flashes
Low battery	flashes 3 times every 30 seconds and there is beep sound
Charging	Keeps on
Switch on	Turns on and keeps o for 3 seconds
Switch off	Flashes 5 times
Paring state	Keeps on

9. Specification

- * Bluetooth Specification v2.1+EDR class 2
- * The latest version of A2DP1.2 and AVRCP1.0 profiles support
- * Supports Bluetooth Headset and Hands-free Profile (HFP 1.5)
- * RF Frequency Range: 2.402-2.480GHZ, 2.4G ISM band
- * Radio Performance: Receive Sensitivity of -90dBm, TX Power Max 4dBm
- * Frequency Response: 20 Hz - 20 KHz, Very high Signal to Noise Ratio (SNR):95 Db, Total Harmonic Distortion (THD):0.1%,
- * Rechargeable 90mAh Li-Polymer Battery
- * Nominal charging time: Max 1.5 hours
- * Talk time: Up to 4.5 hours
- * Standby time: Up to 90 hours

10. Battery information

Your device is powered by a rechargeable battery. The full performance of a new battery is achieved only after two or three complete charge and discharge cycles. The battery can be charged and

discharged hundreds of times, but it will eventually wear out.

Unplug the charger from the electrical plug and the device when not in use. Do not leave a fully charged battery connected to a charger, since overcharging may shorten its lifetime. If left unused, a fully charged battery will lose its charge over time.

Leaving the device in hot or cold places, such as in a closed car in summer or winter conditions, will reduce the capacity and lifetime of the battery. Always try to keep the battery between 15°C and 25°C (59°F and 77°F). A device with a hot or cold battery may not work temporarily, even when the battery is fully charged. Battery performance is particularly limited in temperatures well below freezing.

Do not dispose of batteries in a fire as they may explode. Batteries may also explode if damaged. Dispose of batteries according to local regulations. Please recycle when possible. Do not dispose as household waste.

11 Care and maintenance

Your device is a product of superior design and craftsmanship and should be treated with care. The suggestions below will help you protect your warranty coverage.

- Keep all accessories and enhancements out of the reach of small children.
- Keep the device dry. Precipitation, humidity, and all types of liquids or moisture can contain minerals that will corrode electronic circuits. If your device does get wet, allow it to dry completely.
- Do not use or store the device in dusty, dirty areas. Its moving parts and electronic components can be damaged.
- Do not store the device in hot areas. High temperatures can shorten the life of electronic devices, damage batteries, and warp or melt certain plastics.
- Do not store the device in cold areas. When the device returns to its normal temperature, moisture can form inside the device and damage electronic circuit boards.
- Do not drop, knock, or shake the device. Rough handling can break internal circuit boards and fine mechanics.
- Do not use harsh chemicals, cleaning solvents, or strong detergents to clean the device.
- Do not paint the device. Paint can clog the moving parts and prevent proper operation.

All of the above suggestions apply equally to your device, battery, charger, or any enhancement. If any device is not working properly, take it to the nearest authorized service facility.

FCC Information

This device complies with Part 15 of the FCC rules.

Operation is subject to the following two conditions: (1) this device may not cause harmful interference, and (2) this device must accept any interference received; including interference that may cause undesired operation.

Federal Communications Commission (FCC) Statement

This Equipment has been tested and found to comply with the limits for a Class B digital device, pursuant to Part 15 of the FCC rules. These limits are designed to provide reasonable protection against harmful interference in a residential installation. This equipment generates, uses and can radiate radio frequency energy and, if not installed and used in accordance with the instructions, may cause harmful interference to radio communications. However, there is no guarantee that interference will not occur in a particular installation. If this equipment does cause harmful interference to radio or television reception, which can be determined by turning the equipment off and on, the user is encouraged to try to correct the interference by one or more of the following measures:

- Reorient or relocate the receiving antenna.
- Increase the separation between the equipment and receiver.
- Connect the equipment into an outlet on a circuit different from that to which the receiver is connected.
- Consult the dealer or an experienced radio/TV technician for help.

Warning: Changes or modifications to this unit not expressly approved by the party responsible for compliance could void the user authority to operate the equipment.

Tested to comply with FCC standard. FOR HOME OR OFFICE USE.

Warning :

This equipment complies with FCC RF radiation exposure limits set forth for an uncontrolled environment. & This device and its antenna(s) must not be co-located or conjunction with any other antenna or transmitter.