

4. Initial Web Access

You can access the unit through a web browser by using the "initial LAN IP" at first. The detail procedure is as follows:

- 1 Connect LAN1 port of the unit to your PC using Ethernet cable.
- 2 Configure IP assignment of your PC to DHCP (dynamic assignment). How to configure dynamic IP on your PC is as follows:

For Windows XP:

Start > Setting > Network Connections > Local Area Connection double click > Internet Protocol (TCP/IP) double click > Obtain an IP address automatically and Obtain DNS server address automatically selection > OK

For Windows 7:

Start > Control Panel > View network status and tasks under Network and Internet (View by: Category) > Change adapter settings on the left menu > Local Area Connection right-click > Properties > Internet Protocol Version 4 (TCP/IPv4) double click > Obtain an IP address automatically and Obtain DNS server address automatically selection > OK

The PC will be allocated IP address automatically through the unit.

- 3 Open a web browser, and enter <http://192.168.1.100:8080> in a URL field.
- 4 Type "user/user" in user name/password field, and log into the system. Initial page is displayed.

※ The default SSID and its password are as follows:

SSID: DASAN_GONTxxxxxx
(xxxxxx is the last 6 digit/letters of MAC address of your unit.)
Password: 1234567890a

※ To change the SSID and/or password, move onto Basic Settings > Wireless LAN > SSID Setting on the web, and click Modify. And change them and click Apply. And then click Apply Config on top of page, and reboot the unit.

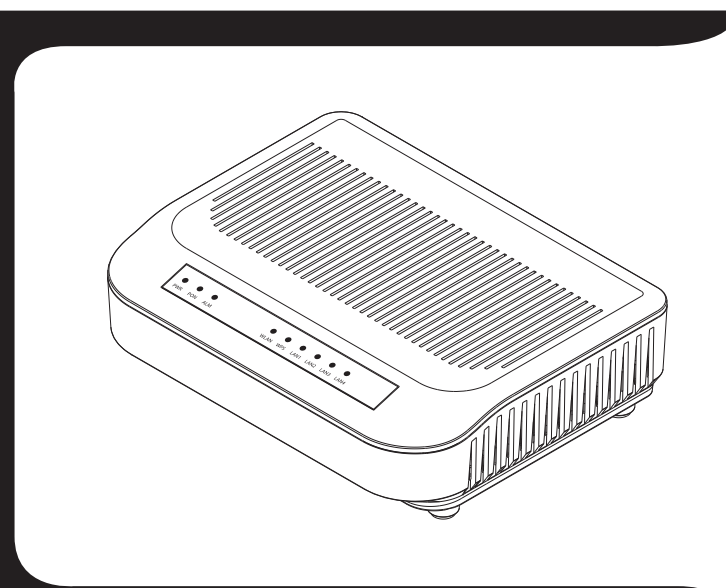

H660W QIG (Quick Guide)

V1

GPON Optical Network Terminal (ONT) with Wi-Fi

Information furnished by Dasan Networks, Inc. is believed to be accurate and reliable. However, no responsibility is assumed by Dasan Networks for its use, nor for any infringements of patents or other rights of third parties which may result from its use. No license is granted by implication or otherwise under any patent or patent rights of DASAN Networks. DASAN Networks reserves the rights to change specifications at any time without notice.
Copyright © 2014 by DASAN Networks, Inc. All rights reserved.

DASAN Networks, Inc.

www.dasannetworks.com/en

1. Caution

- This unit is indoor use and all the communication wirings are limited to inside of the building.
- Never look directly at the fiber TX port and fiber cable ends when they are powered on.
- DO NOT use near water.
- DO NOT place near high temperature source.
- DO NOT disassemble the unit.
- DO NOT operate the unit in a location where the maximum ambient temperature exceeds 104°F.
- Open optical connections must use a protective cap under all circumstances to protect against physical damage and dirt.
- Avoid impact stresses when handling connectors. Physical damage to the faces of optical connections impairs transmission quality (higher attenuation).
- Avoid a bend radius in excess of 1.18 in for fiber optic links.
- Check the available voltage supply.
- It may only be repaired by authorized service personnel.

FCC Certification Requirements

• Caution

Any changed or modifications not expressly approved by the party responsible for compliance could void the user's authority to operate this equipment.

• FCC RF exposure requirements

The antenna used with this module must be installed to provide a separation distance of at least 20cm from all persons, and must not transmit simultaneously with any other antenna or transmitter except in accordance with FCC multi-transmitter product procedures.

• User Information

This device complies with Part 15 of the FCC's Rule. Operation is subject to the following to conditions;

1. This device may not cause harmful interference, and
2. This device must accept any interference received, including interference that may cause undesirable operation.

This equipment has been tested and found to comply with the limits for a Class B digital device, pursuant to part 15 of the FCC Rules. These limits are designed to provide reasonable protection against harmful interference in a residential installation. This equipment generates, uses and can radiate radio frequency energy and, if not installed and used in accordance with the instructions, may cause harmful interference to radio communications. However, there is no guarantee that interference will not occur in a particular installation. If this equipment does cause harmful interference to radio or television reception, which can be determined by turning the equipment off and on, the user is encouraged to try to correct the interference by one or more of the following measures:

- Reorient or relocate the receiving antenna.
- Increase the separation between the equipment and receiver.
- Connect the equipment into an outlet on a circuit different from that to which the receiver is connected.
- Consult the dealer or an experienced radio/TV technician for help.

- 1 -

2. Introduction

2.1 Package Contents

- H660W
- Power Adapter
- RJ45 UTP Cable (CAT5e)
- QIG (Quick Guide)

2.2 Specification

Item	Specification
System Memory	128MB DDR3
Flash Memory	128MB Nand Flash
Uplink Interface	1 GPON port (1G, SC/UPC)
Service Interface	4 10/100/1000Base-T ports (RJ45)
Wireless	Internal antenna IEEE 802.11b/g/n compliant Bandwidth: 2.4GHz Two Transmit and Two Receive path (2T2R)
LED	PWR, PON, ALM, WLAN, WPS, LAN1~4
Power Adapter	Output: 12VDC/1A
Operating Temp.	0 to 40°C
Operating Humidity	5 to 95% (non-condensing)
Dimensions (W x D x H)	160 x 125 x 43 mm
Button	ON/OFF power, WLAN, WPS, RESET

- 2 -

2.3 Rear View

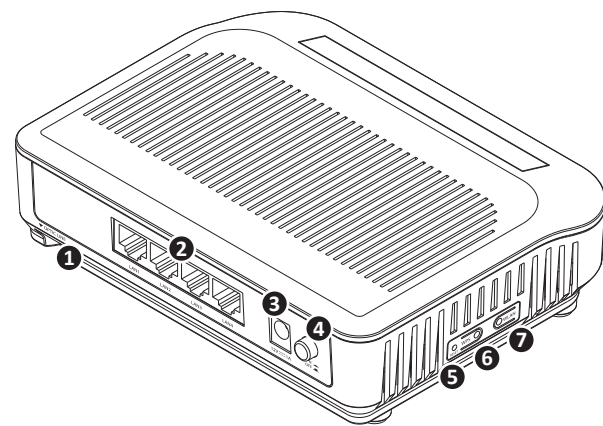

Item	Description
① OPTIC LINE	Connect the network.
② LAN1~4	Connect PC or LAN.
③ Power Port	Connect power adapter.
④ ON/OFF	Turn on/off the unit.
⑤ RESET	Reboot the unit.
⑥ WPS	Enable WPS process.
⑦ WLAN	Enable WiFi function.

- 3 -

2.4 Front View (LEDs)



Label	Light	Status	Description	
PWR	Green	On	The system is turned on.	
		Off	The system is turned off.	
PON	Red	On	No optic signal.	
		Green	On	Optic signal normal. Normally registered.
		Blink	Firmware being downloaded. Do not turn off the unit.	
		On	Service held after registered normally.	
ALM	Orange	Blink	ONT not registered. Keep blinking before registration process finished.	
		Off	ONT normally operating.	
WLAN	Green	On	WiFi function enabled.	
		Off	WiFi function disabled.	
WPS	Green	Blink	In progress.	
		On	Success (for 5 seconds)	
LAN 1~4	Green	On	The 1G port link is up.	
		Blink	The 1G transmit or receive activity is present on the service port.	
		On	The 10/100M port link is up.	
		Blink	The 10/100M transmit or receive activity is present on the service port.	
		Off	Link is down.	

- 4 -

3. Installation

- 1 Remove the protective cap of GPON port.
- 2 Connect an SC/UPC connector optic cable to the port.
- 3 And then arrange optic line on splice tray, not to give damage to GPON connection due to any possible pull.

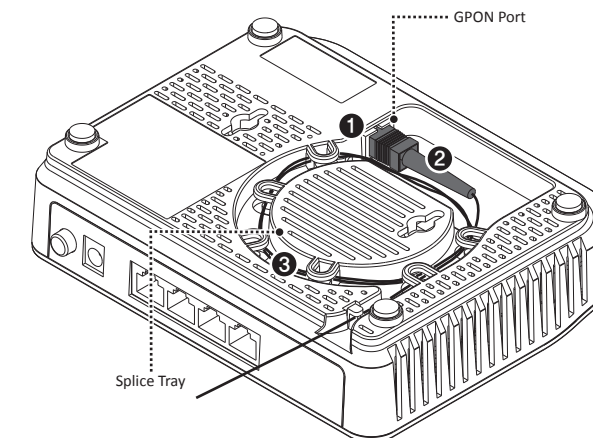

- 5 -

- 4 Connect the Ethernet cable from LAN port to PC.
- 5 Connect a power adapter from power port to a live AC outlet.
- 6 Turn on the unit by pushing the power button.
- 7 Push WLAN button to enable WiFi.

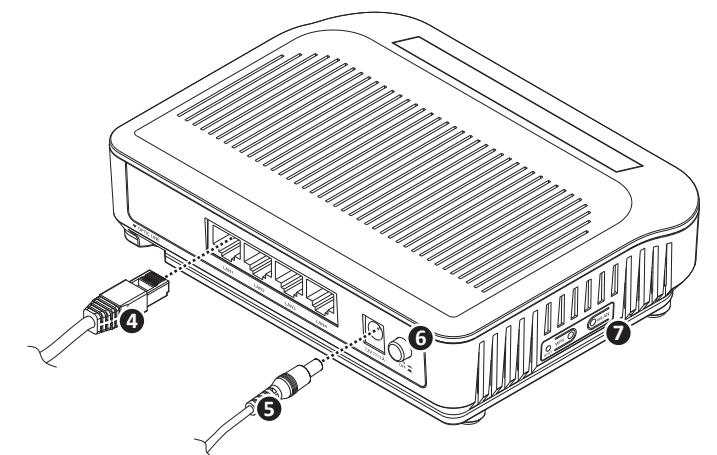

- 6 -