

GEYE **900**

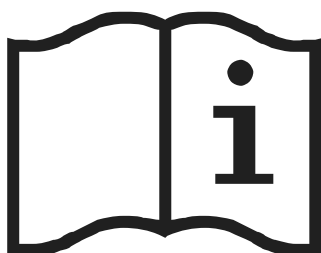

- EN
- FR
- ES
- DE
- IT
- NL
- PT
- PL
- HU
- RO
- SK
- CS
- SV
- BG
- HR
- SL
- EL
- TR
- RU
- VI
- ID
- ZH
- JA
- ZT
- TH
- KO
- AR
- FA

DESCRIPTION



short press:
Start/Pause the video

short press:
Take a photo / Take a photo in
the video

long press:
Turn on the camera and start recording /
stop recording

long press:
Turn on the camera and take a
picture



long press:
On/Off



long press:
WIFI On/Off

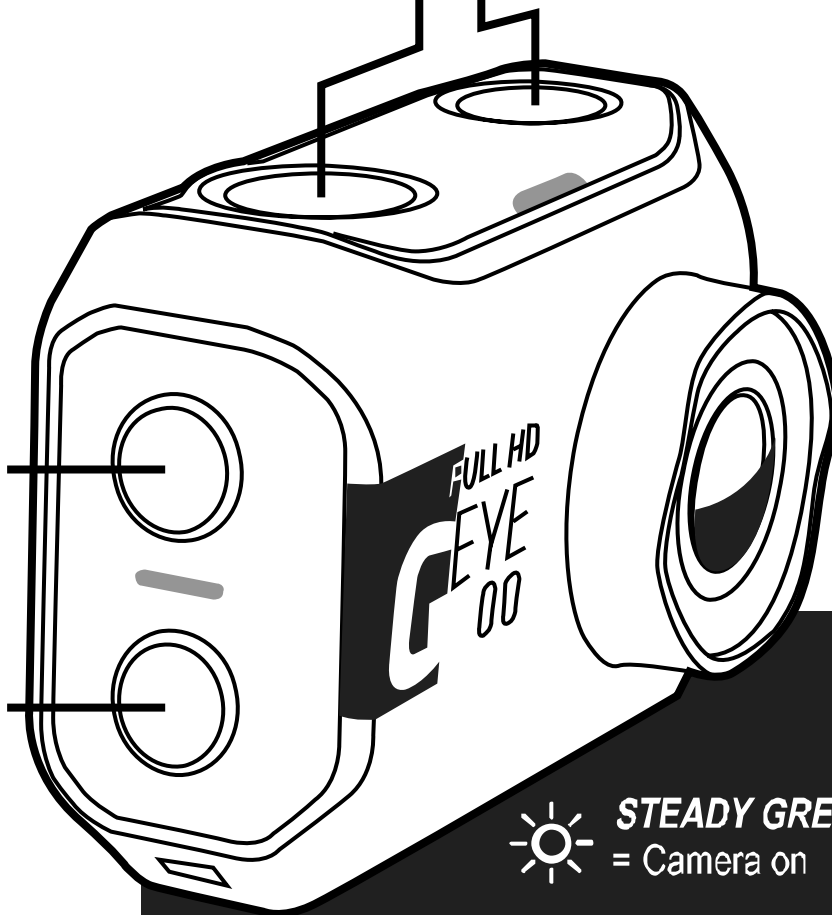

STEADY GREEN LED

= Camera on



STEADY RED LED

= Video paused or camera charging.

FLASHING RED LED

= Photo or video recording in progress or low
battery.

FIRST STEPS

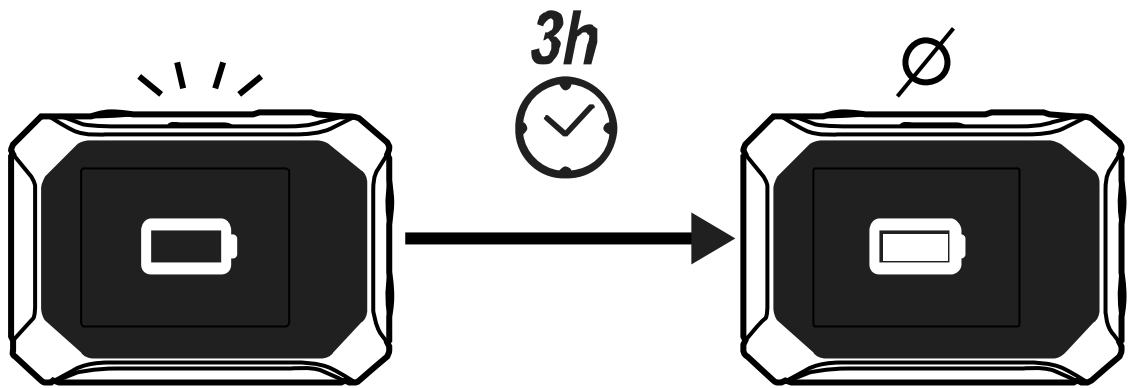
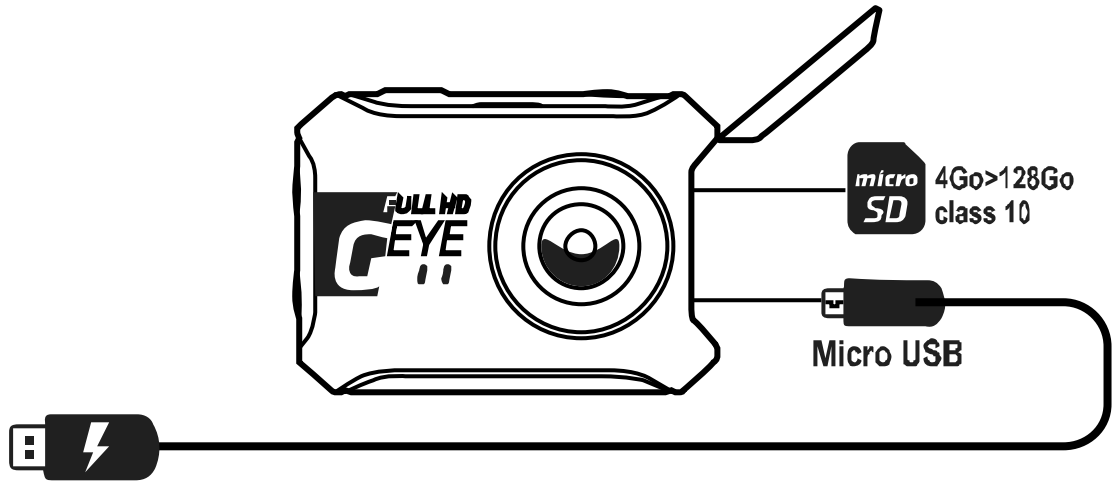

USE WITH WATERPROOF CASE

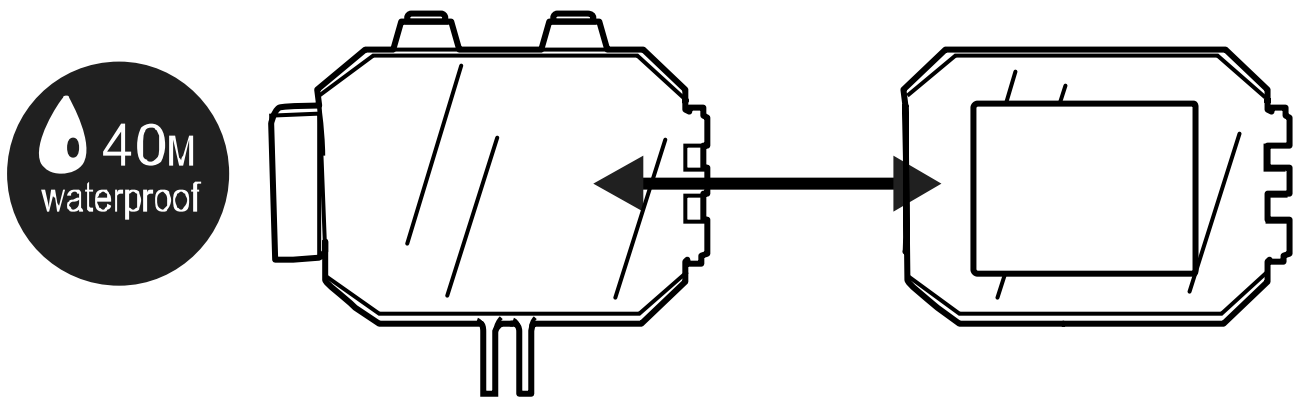

- Standard rear door (full): waterproof to 40m
To ensure a perfect seal, it is important to keep the seal clean.
Rinse with clean water.
- Perforated rear door: for dry and dust-free environments:
access the touchscreen and more efficient sound recording.

CHANGING THE REAR DOOR:

Open the case fully, pull on the side of the door until it comes apart.
Align the new door with the hinge and close the door until it fits snugly.



Use an anti-fog insert (accessory sold separately at DECATHLON)

MENU

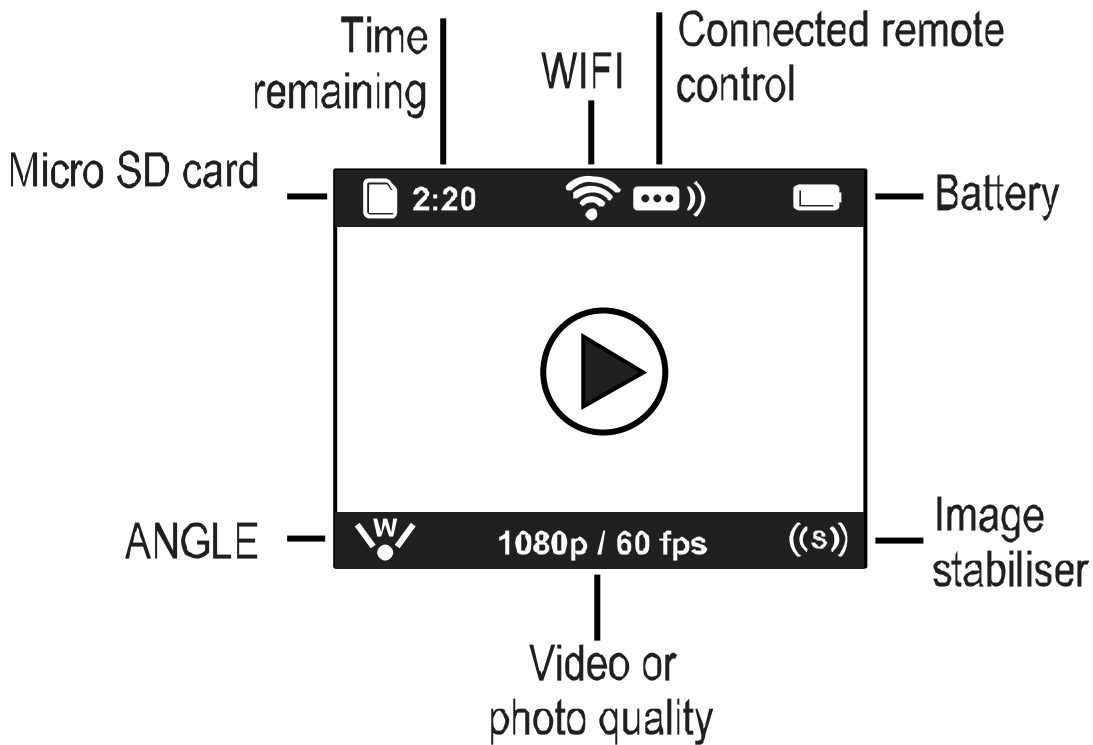

MENU

GENERAL SETTINGS

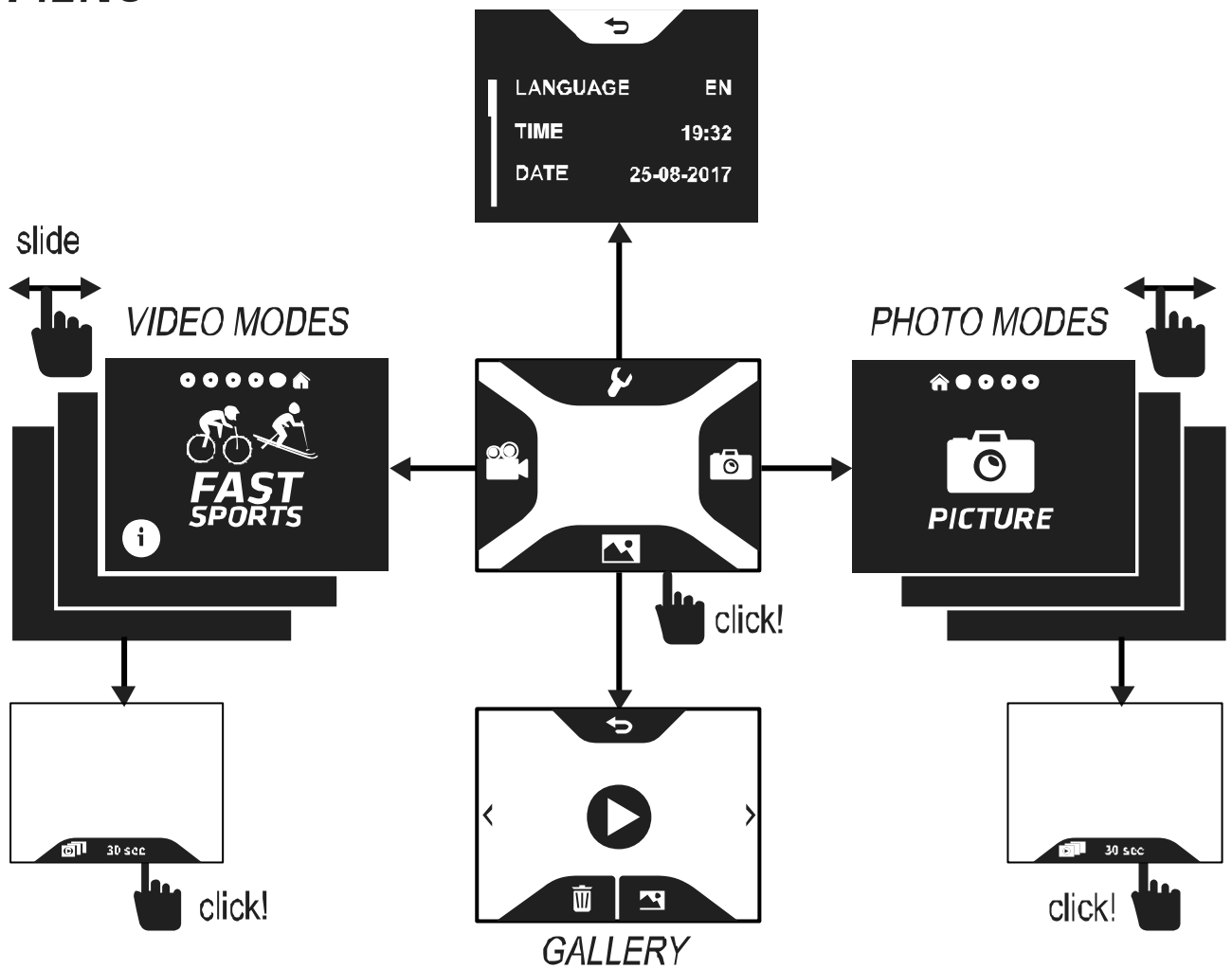

VIDEO MODES



Optimised settings for dynamic sports
1080p (Full HD)
60fps
 wide angle and stabiliser



Optimised settings for slow sports
1080p (Full HD)
30fps
 wide angle

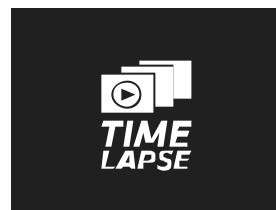

Timelapse video
1photo / 2s, 5s, 10s,
30s, 60s, 300s



Slow motion video
720p / 120fps

 CUSTOM	RESOLUTION	NTSC (fps)	PAL (fps)	Field of view
	4K 2.7K 2.7K (4:3) 1440P 1080P 960P 720P	15 24/30 30 24/30 24/30/60 60 30/60/120	12.5 24/25 25 24/25 24/25/50 50 25/50/120	W : Wide W/M : Wide/Medium W : Wide W : Wide W/M/N : Wide/Medium/Narrow W : Wide W/M/N : Wide/Medium/Narrow

PHOTO MODES



Classic photo
 16 MP, 12 MP, 8 MP, 5 MP

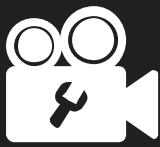
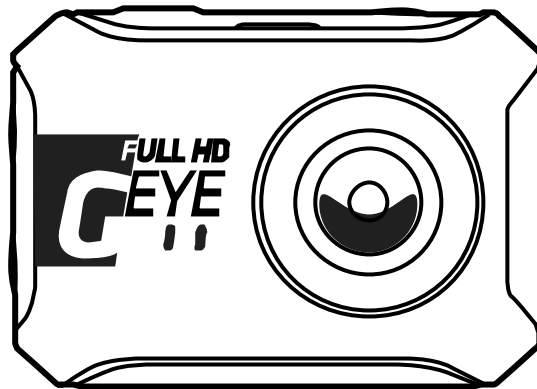
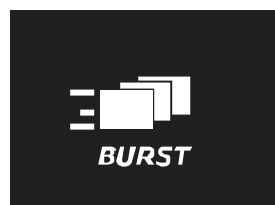

Burst photos
 x30 pics / 1s, 2s, 3s, 6s
 x10 pics / 1s, 2s, 3s
 x5 pics/s
 x3 pics/s

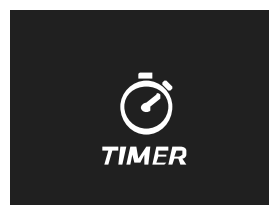

Timer
 1s, 3s, 5s, 10s, 30s

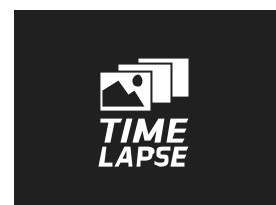

Timelapse photo
 1 photo / 2s, 5s, 10s, 30s, 60s, 300s

GENERAL SETTINGS (1/3)

SOUND
On
Off

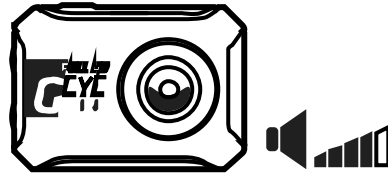

LEDS
On
Off

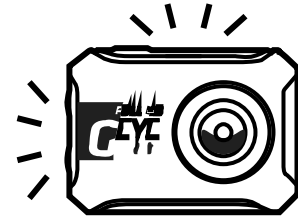

ROTATE
UP
DOWN
AUTO

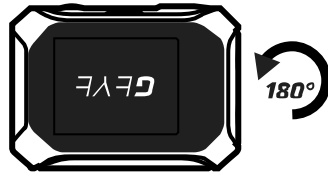

LCD STANDBY
On
Off

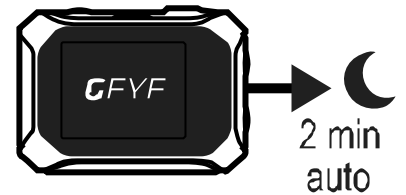

AUTO On/Off
On
Off

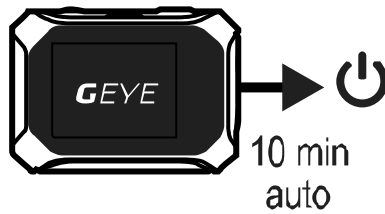

REVIEW
On
Off

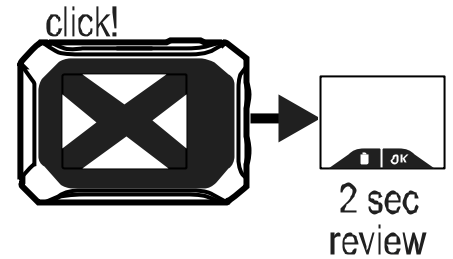

GENERAL SETTINGS (2/3)

LAST MODE
On
Off

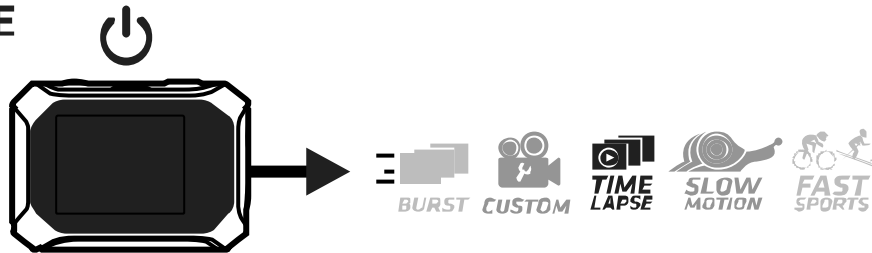

Activate the camera on the last video/photo mode

FAST REC:
On
Off



Activate the camera and start the video/photo

PAUSE
On
Off



Activate the pause recording function

GENERAL SETTINGS (3/3)

DISTORTION:

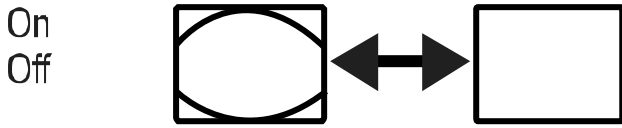

LOOP

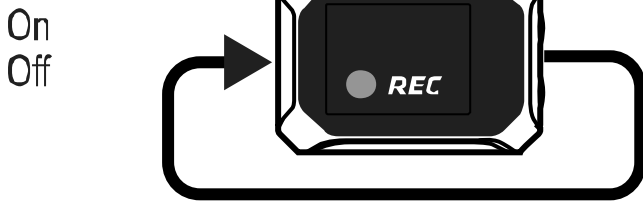

OUTPUT

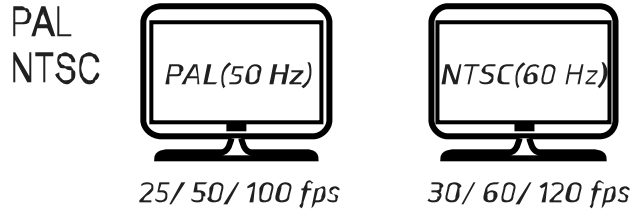

RESET ALL

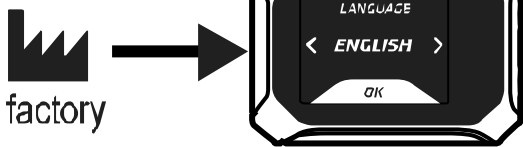

FORMAT SD

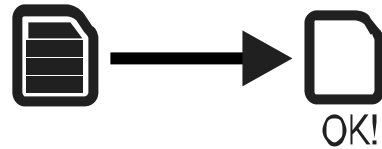

VIEW / CONTROL

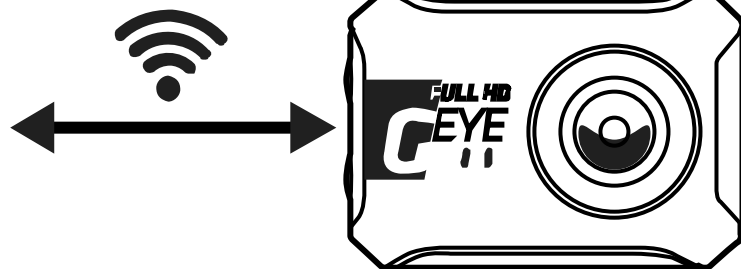

View, configure and control your camera via the wifi of your smartphone.

Activate the wifi of your camera and of your smartphone then follow the instructions of the application.

REMOTE CONTROL (OPTIONAL)

Pair your remote control by following the procedure after activating the REMOTE function in the camera's general settings.

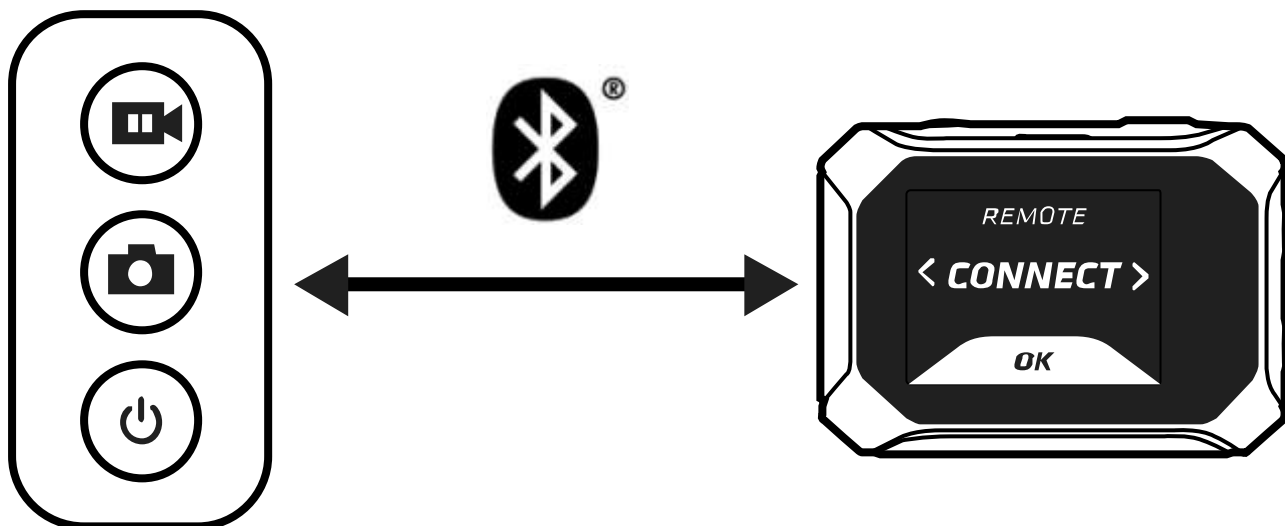

TV VIEWING

Using a mini-HDMI cable (optional) you can broadcast your photo/video content on an HD television.

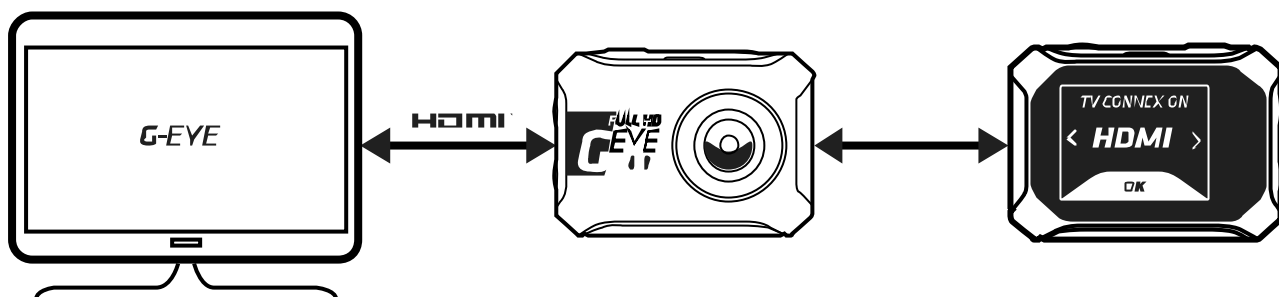

ATTACH THE CAMERA

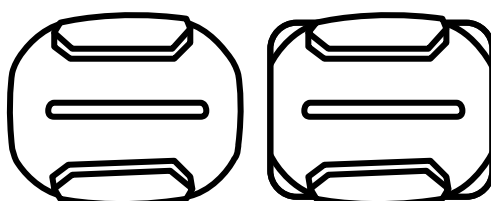

Attach the adhesive mounts to clean, smooth surfaces at room temperature only. Wait 24 hours before use.

TECHNICAL SPECIFICATION

GEYE900 Weight & Dimensions:

Weight: 106g / 207g w casing

Height: 50mm

Width: 68mm

Depth: 27mm / 36mm with lens

GEYE900 Battery type:

Li-ion Battery, 1480mAh

Main material: ABS

GENERAL PRODUCT SAFETY

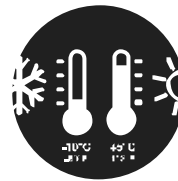

Handle the device with care, do not drop or expose it to serious impacts»

Caution, this product is not waterproof without its waterproof case. Do not expose it to water or submerge it

For greater safety, do not touch the buttons while in use. Losing concentration can be dangerous

Do not disassemble this product as this could cause damage and void the warranty

Using this device in extreme cold (at temperature below -10°C) could cause a decrease in the battery's capacity, and hence reduce the product's battery life

LIMITED LIABILITY

DECATHLON is not responsible for accidents or injuries that result from handling or use of this product while participating in high-risk sports. Specifically, DECATHLON wishes to inform the user about the possible risk of losing concentration due to handling the product in dangerous conditions.

The user is warned that s/he assumes all legal responsibility for the shooting, sharing, and publishing of images captured by this product.

EC DECLARATION OF CONFORMITY

DECATHLON hereby declares that the G-EYE 900 device complies with essential requirements and with other relevant stipulations of the 2014/53/EU directive.

The EC declaration of conformity is available at the following web link:

www.geonaute.com/en/ec-declaration-conformity

RECYCLING

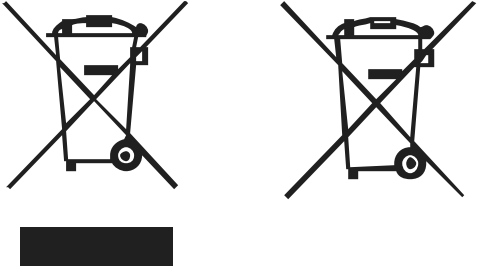

CONTACT US

Contact us at
www.customercare.geonaute.com

DESCRIPTION



appui court :
Démarré/Met en pause la vidéo

appui court :
Prend une photo / Prend une photo dans la vidéo

appui long :
Allume la caméra et démarre l'enregistrement / stoppe l'enregistrement

appui long :
Allume la caméra et prend une photo

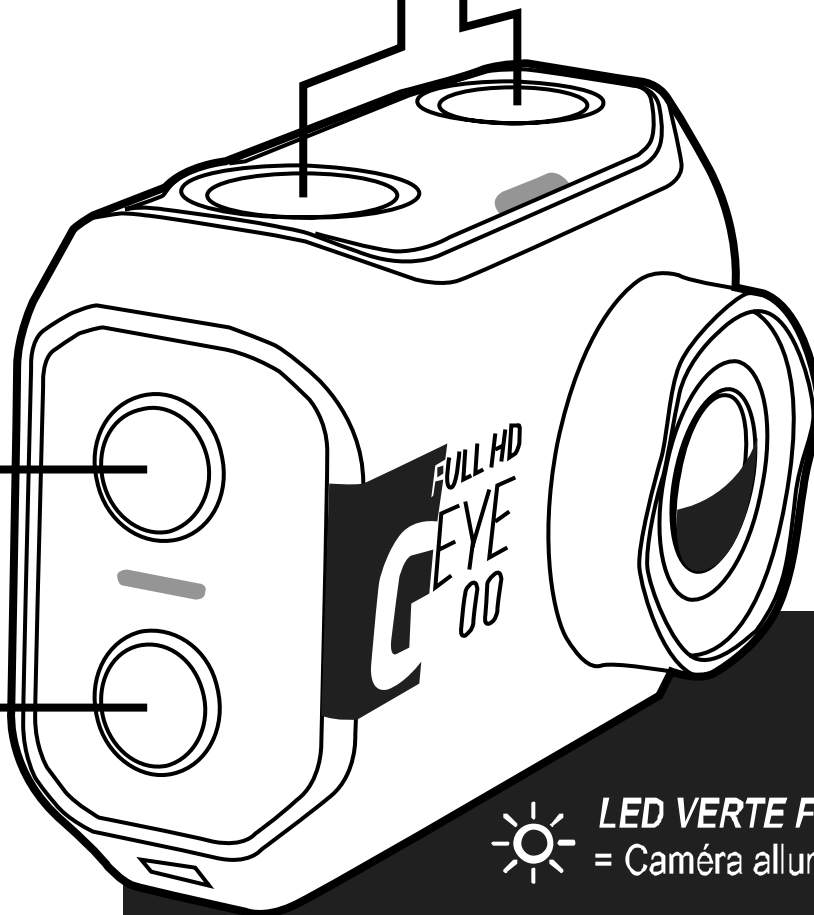

appui long :
On/Off



appui long :
WIFI On/Off



LED VERTE FIXE

= Caméra allumée



LED ROUGE FIXE

= Vidéo en pause ou caméra en charge.

LED ROUGE CLIGNOTANTE

= Photo ou enregistrement vidéo en cours ou batterie faible.

PREMIERS PAS

FR

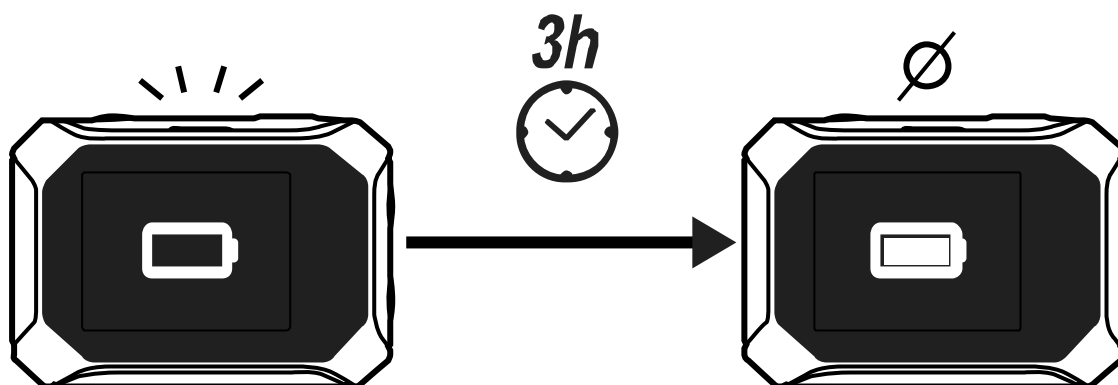
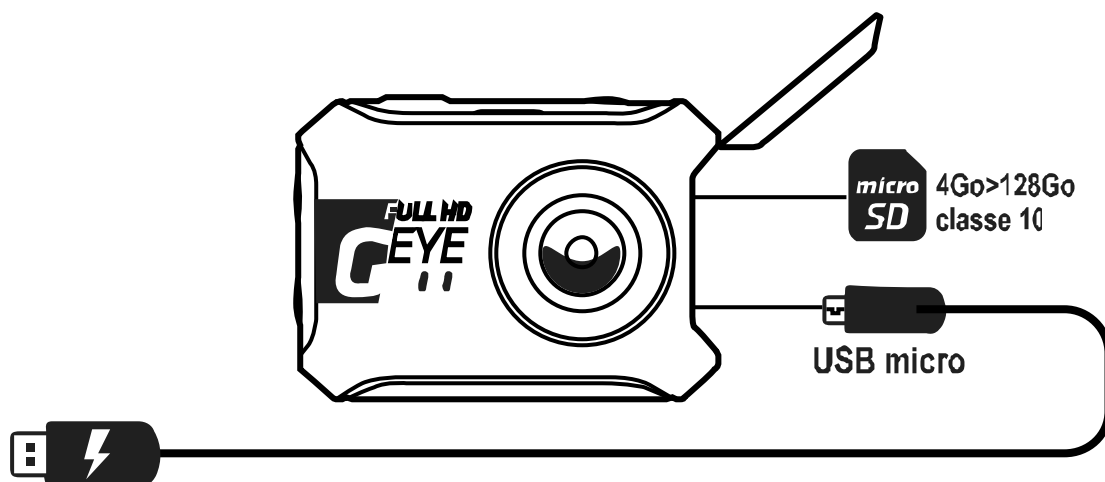

UTILISATION AVEC CAISSON ÉTANCHE

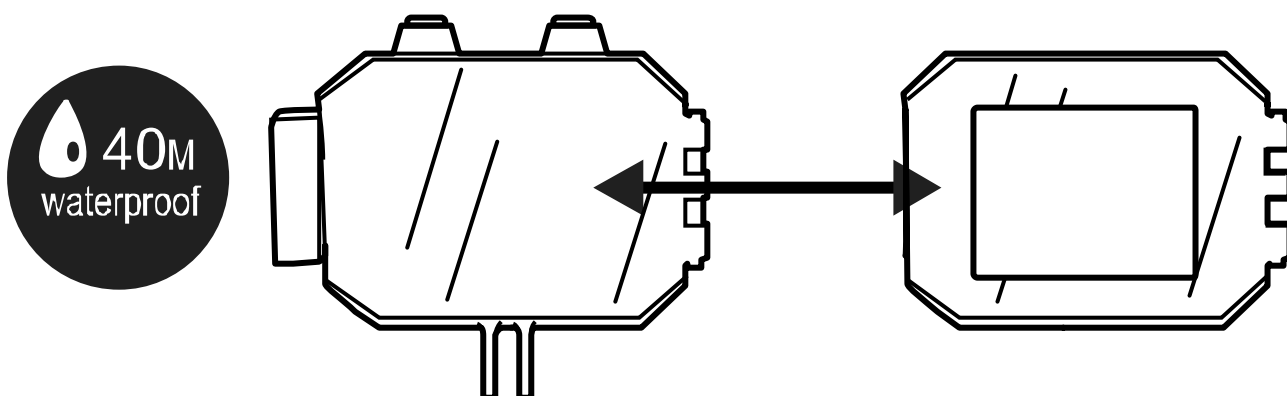

- Porte arrière standard (pleine): étanchéité jusqu'à 40m
Afin de garantir une étanchéité parfaite, il est important de garder le joint d'étanchéité propre.
Rincer à l'eau claire.
- Porte arrière ajourée: pour milieux sec et sans poussière:
accès à l'écran tactile et prise de son plus performante.

CHANGEMENT DE LA PORTE ARRIÈRE :

Ouvrez le boîtier entièrement, tirez sur la porte sur le côté jusqu'à ce qu'elle se déboîte. Alignez la nouvelle porte avec la charnière et refermez la porte jusqu'à ce qu'elle s'emboîte parfaitement.



Utilisez un anti-buée (accessoire vendu séparément chez DECATHLON)

MENU

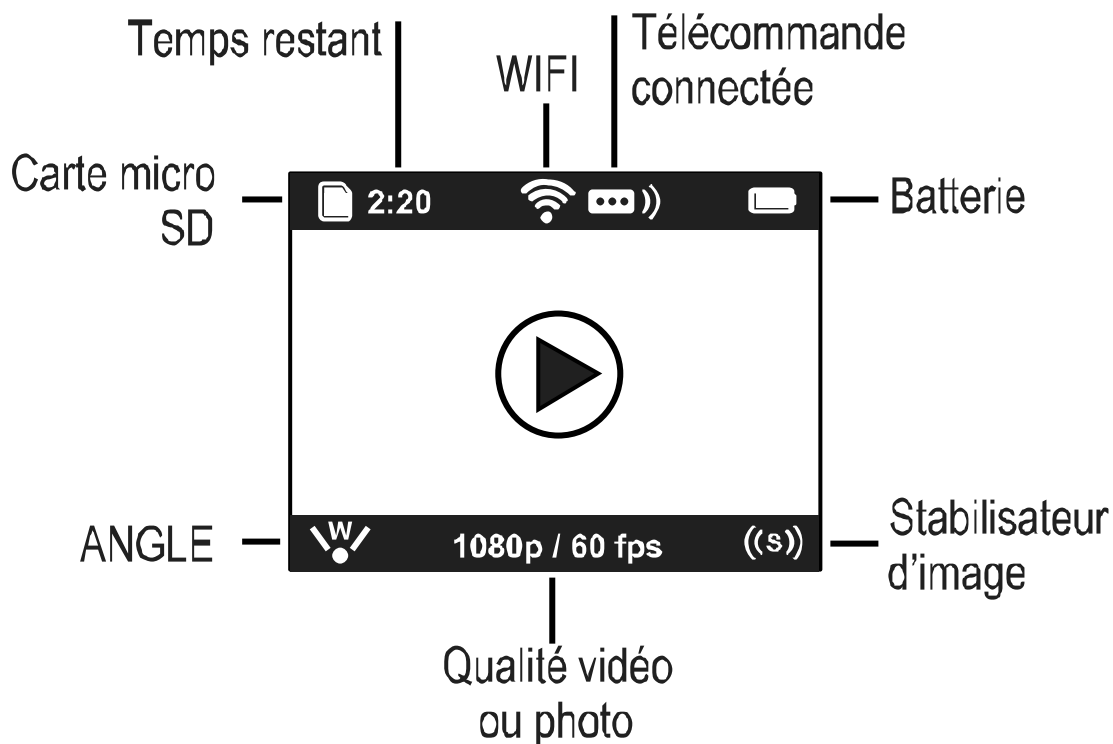

MENU

PARAMÈTRES GÉNÉRAUX

FR

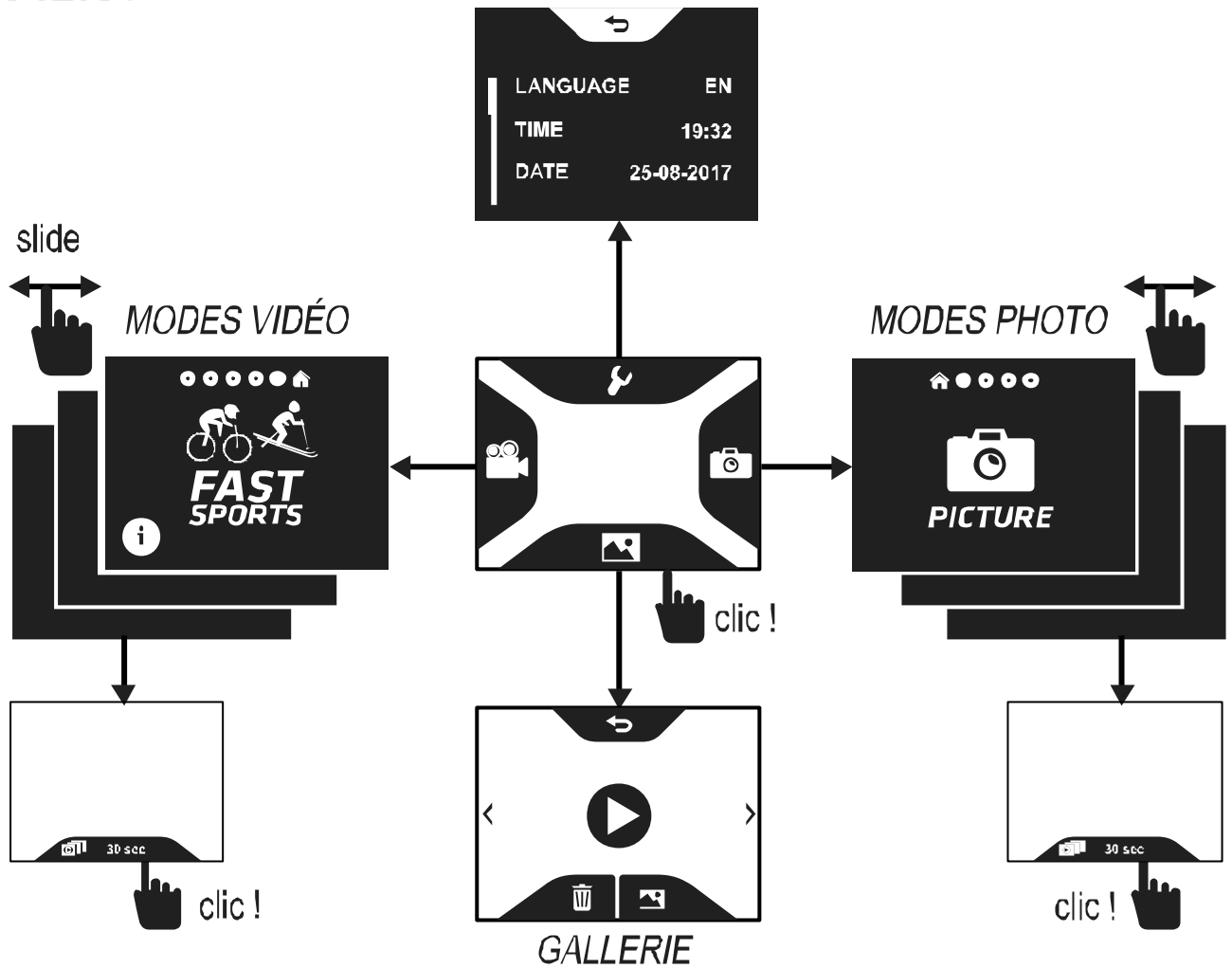

MODES VIDÉO



Réglages optimisés pour sports dynamique
1080p (Full HD)
60fps
angle large et stabilisateur



Réglages optimisés pour sports lents
1080p (Full HD)
30fps
angle large

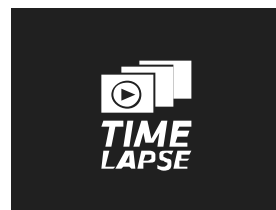

Timelapse video
1photo / 2s, 5s, 10s,
30s, 60s, 300s



Ralenti video
720p / 120fps

 CUSTOM	RÉSOLUTION	NTSC (fps)	PAL (fps)	Champ de vision
	4K 2.7K 2.7K (4:3) 1440P 1080P 960P 720P	15 24/30 30 24/30 24/30/60 60 30/60/120	12.5 24/25 25 24/25 24/25/50 50 25/50/120	W : Large W/M : Large/Moyen W : Large W : Large W/M/N : Large/Moyen/Etroit W : Large W/M/N : Large/Moyen/Etroit

MODES PHOTO

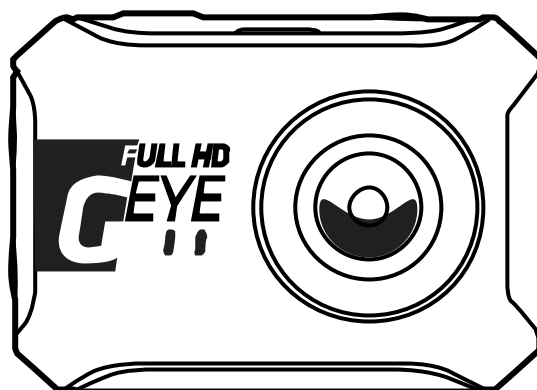
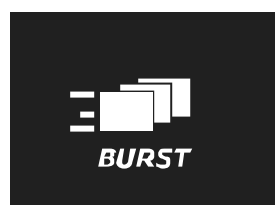
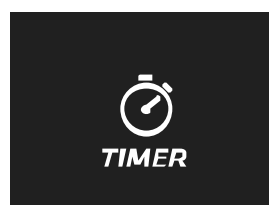

Photo classique
 16 MP, 12 MP, 8 MP, 5 MP



Photos en rafale
 x30 images/1s, 2s, 3s, 6s
 x10 images/1s, 2s, 3s
 x5 images/s
 x3 images/s



Retardateur
 1s, 3s, 5s, 10s, 30s

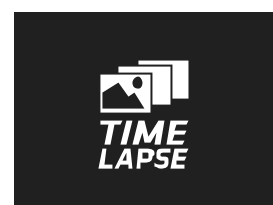

Timelapse photo
 1 photo / 2s, 5s, 10s, 30s, 60s, 300s

PARAMÈTRES GÉNÉRAUX (1/3)

SON
On
Off



LEDS
On
Off

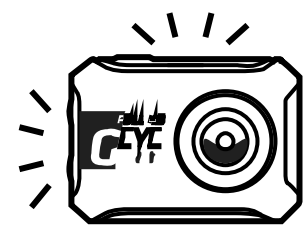

RETOURNER
HAUT
BAS
AUTO

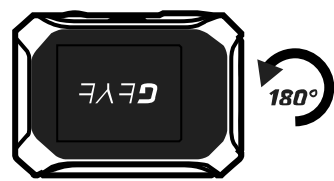

VEILLE LCD
On
Off

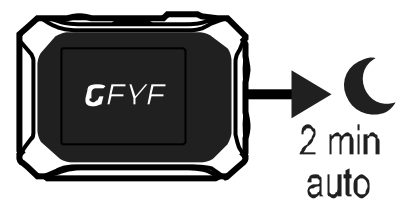

AUTO On/Off
On
Off

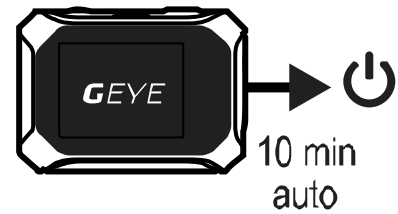

APERÇU
On
Off

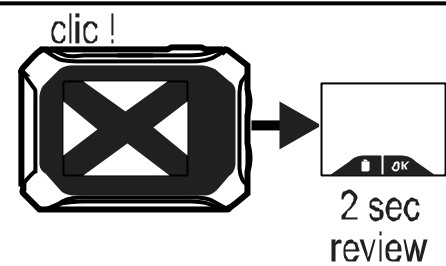

PARAMÈTRES GÉNÉRAUX (2/3)

DERNIER MODE
On
Off

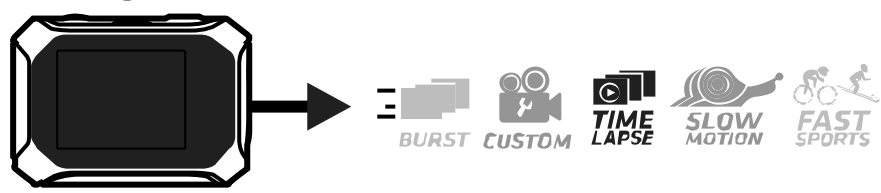

Active la caméra sur le dernier mode vidéo/photo

FAST REC :
On
Off

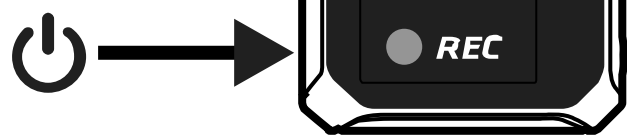

Active la caméra et démarre la vidéo/photo

PAUSE
On
Off

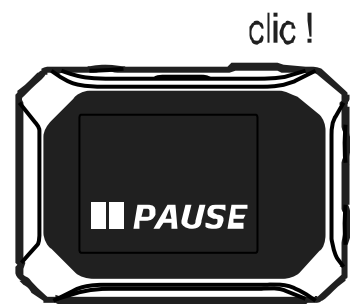

Active la fonction pause enregistrement

PARAMÈTRES GÉNÉRAUX (3/3)

DISTORSION :

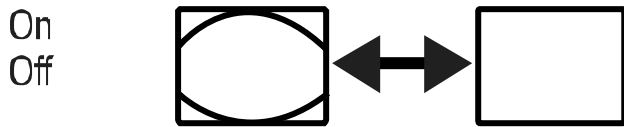

BOUCLE VIDEO

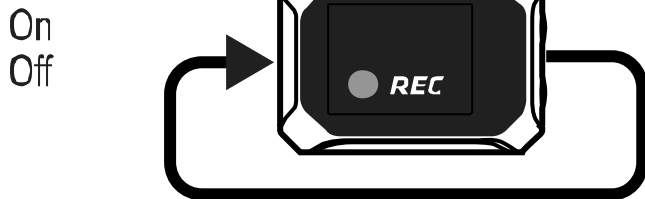

SORTIE

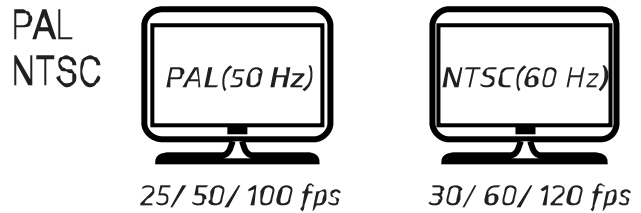

RÉINITIALISER TOUT

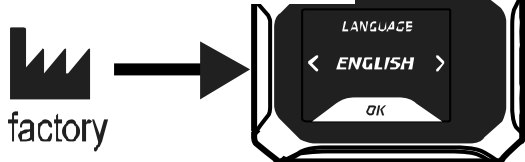

FORMATER SD

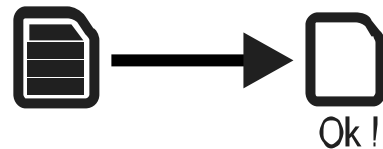

VISUALISER / PILOTER

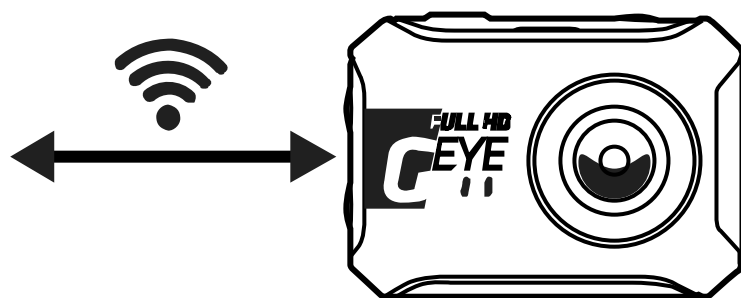
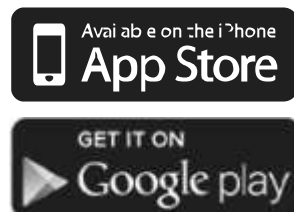

Visualisez, paramétrez et pilotez votre caméra via le wifi de votre smartphone.

Activez le wifi de votre caméra et de votre smartphone puis suivez les instructions de l'application.

TÉLÉCOMMANDE (OPTIONNELLE)

Appairez votre télécommande en suivant la procédure après avoir activé la fonction REMOTE dans les paramètres généraux de la caméra.

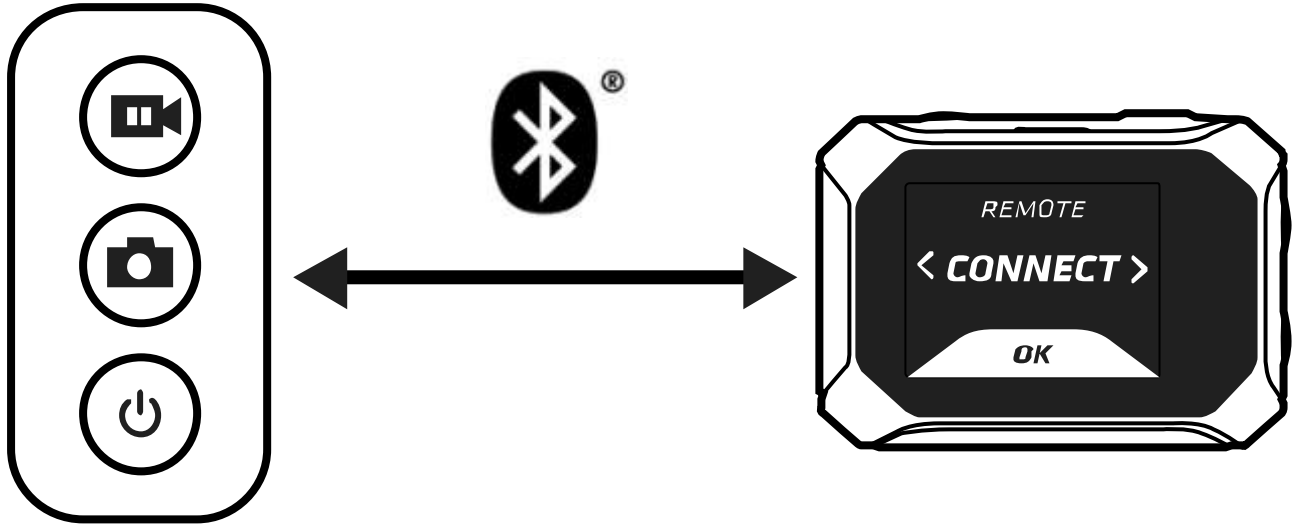

VISUALISATION TV

A l'aide d'un câble mini-HDMI (en option) vous pouvez diffuser votre contenu photo/vidéo sur un téléviseur HD.

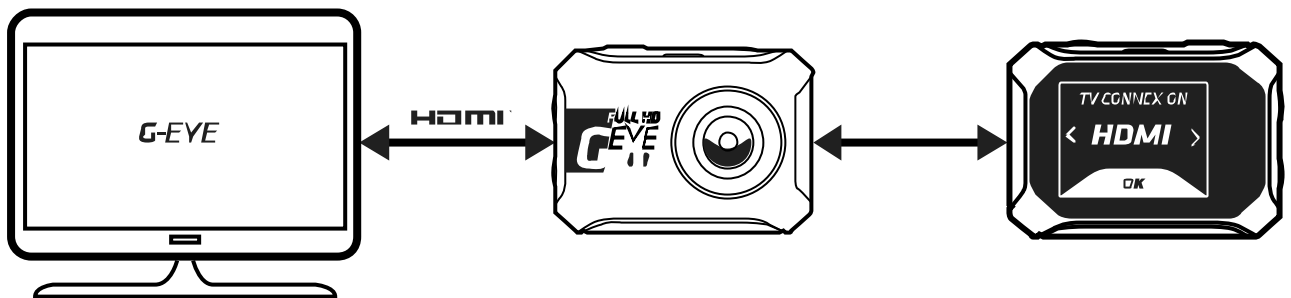

FIXER LA CAMÉRA

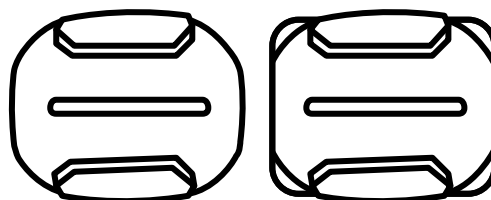

Fixer les supports adhésifs sur des surfaces propres et lisses à température ambiante uniquement.

Attendre 24 h avant utilisation.

CARACTÉRISTIQUES TECHNIQUES

Poids et dimension GEYE900 :

Poids : 106g / 207g avec boîtier

Hauteur : 50mm

Largeur : 68mm

Profondeur : 27mm / 36mm avec verres

Type batterie GEYE900 :

Batterie Li-ion, 1480mAh

Matière principale : ABS

SÉCURITÉ GÉNÉRALE DU PRODUIT

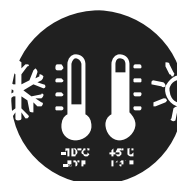

Manipulez avec précautions, ne faites pas tomber et n'exposez pas à des impacts sérieux»

Attention, ce produit n'est pas étanche s'il n'est pas protégé par son boîtier étanche. Ne l'exposez pas à de l'eau et ne le plongez pas sous l'eau

Pour plus de sécurité, ne touchez pas les boutons en cours d'utilisation. Une perte de concentration peut être dangereuse

Ne démontez pas ce produit, car cela pourrait l'endommager et annuler la garantie

Si vous utilisez ce produit alors qu'il fait très froid (à des températures inférieures à -10 °C), la capacité de la batterie et sa durée de vie peuvent diminuer

RESPONSABILITÉ LIMITÉE

DECATHLON n'est pas responsable des accidents ou des blessures qui résultent de la manipulation ou de l'utilisation de ce produit en cas d'utilisation dans le cadre de sports à haut risque. Spécifiquement, DECATHLON souhaite informer l'utilisateur sur le risque possible de perte de concentration suite à la manipulation du produit dans des conditions dangereuses.

L'utilisateur est prévenu(e) qu'il/elle assume toute responsabilité légale pour la prise, le partage et la publication d'images capturées par ce produit.

DÉCLARATION DE CONFORMITÉ CE

Par la présente, DECATHLON déclare que l'appareil G-EYE 900 est conforme aux exigences essentielles et aux autres dispositions pertinentes de la directive 2014/53/CE.

La déclaration de conformité CE est disponible au lien internet suivant : www.geonaute.fr/fr/declaration-conformite

RECYCLAGE



CONTACTER L'ÉQUIPE

Contactez-nous sur
www.support.geonaute.com

DESCRIPCIÓN



pulsación corta:
Iniciar/Pausar vídeo

pulsación larga:
Encender la cámara y empezar a grabar/
detener la grabación



pulsación corta:
Tomar una foto/Tomar una foto
en el vídeo

pulsación larga:
Encender la cámara y tomar
una foto



**pulsación
larga:**
On/Off



**pulsación
larga:**
WIFI On/Off

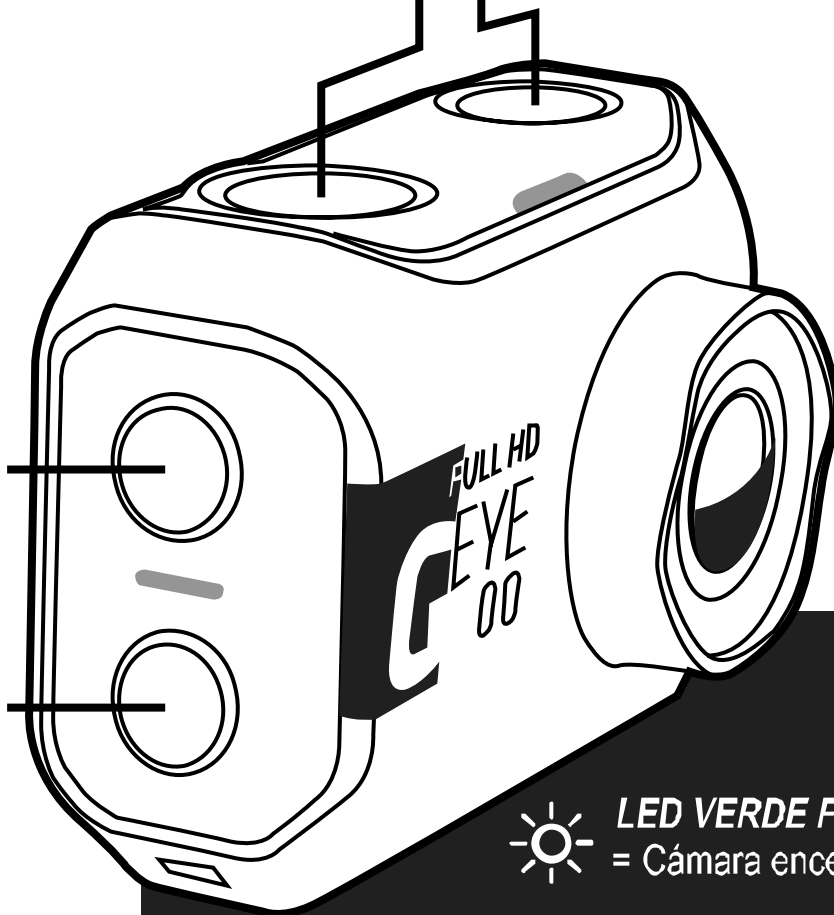

LED VERDE FIJO
= Cámara encendida



LED ROJO FIJO
= Vídeo en pausa o cámara en carga.

LED VERDE INTERMITENTE

= Grabación de foto o vídeo en curso o batería baja.

PRIMEROS PASOS

ES

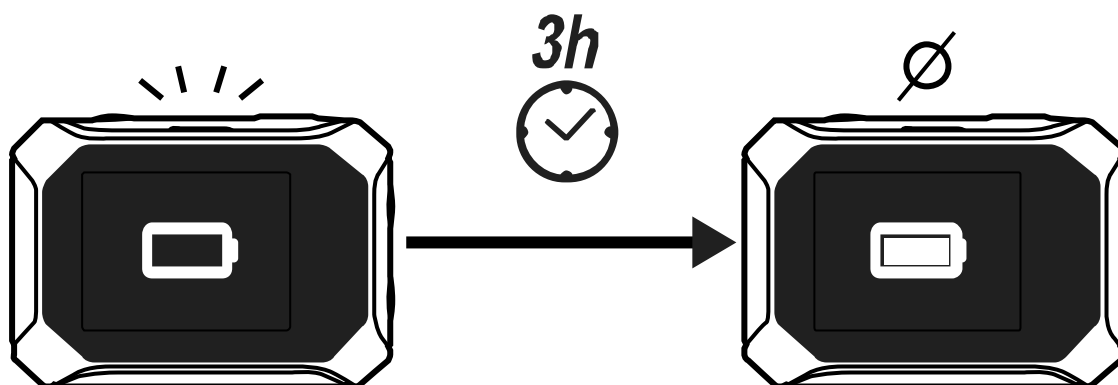
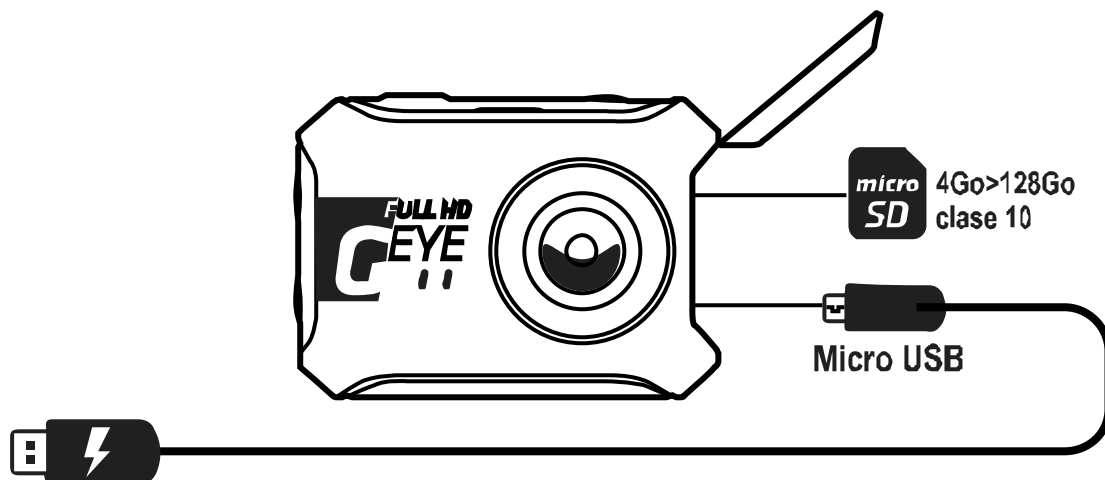

USO CON CAJA ESTANCA

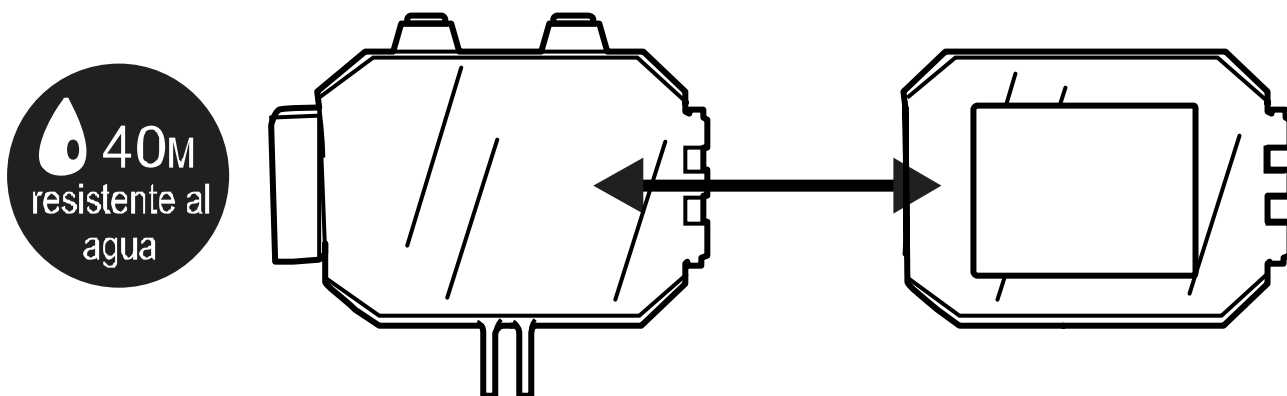

- puerta trasera estándar (total): resistente al agua hasta 40 metros
Para asegurar un cierre perfecto, es importante mantener la junta limpia.
Enjuagar con agua limpia.
- Puerta trasera perforada: para ambientes secos y sin polvo:
acceso a la pantalla táctil y grabación de sonido más eficiente.

CAMBIO DE LA PUERTA TRASERA:

Abre la caja completamente y tira de la puerta por un lado hasta quitarla.

Alinea la nueva puerta con la bisagra y cierra la puerta hasta que encaje perfectamente.



Coloca un inserto anti-vaho (accesorio que se vende por separado en DECATHLON)

MENÚ

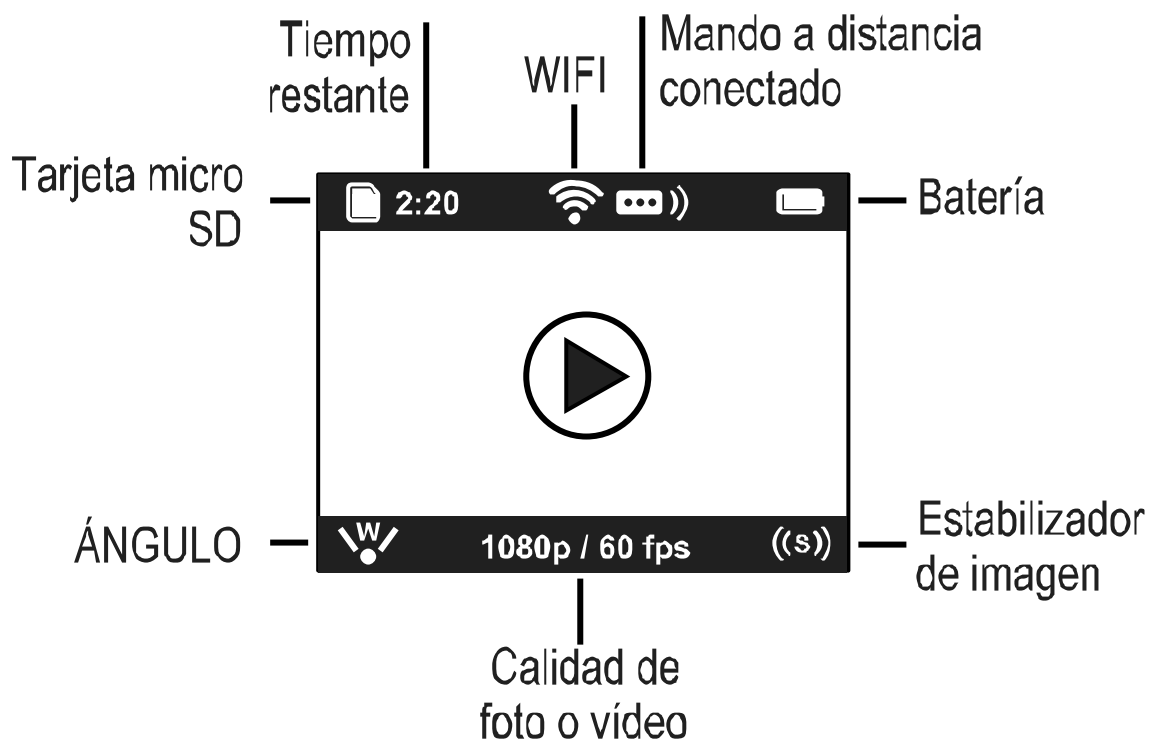

MENÚ

AJUSTES GENERALES

ES

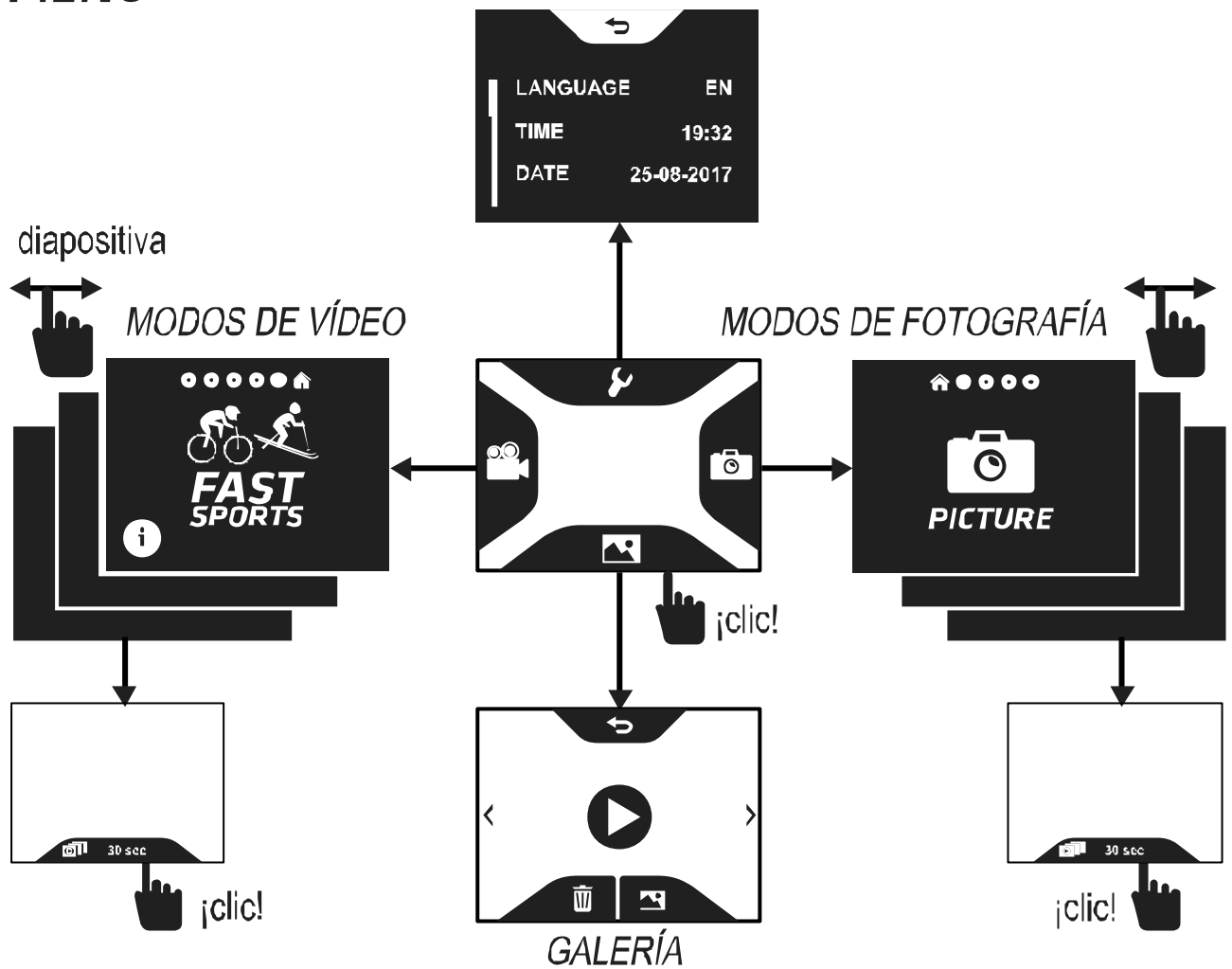

MODOS DE VÍDEO



Ajustes optimizados para deportes dinámicos
1080p 60fps (Full HD)
gran angular y estabilizador



Ajustes optimizados para deportes lentos
1080p 30fps (Full HD)
gran angular

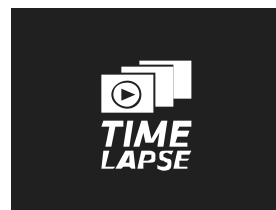

Vídeo a intervalos
1 foto / 2, 5, 10s, 30s, 60s, 300s



Vídeo en cámara lenta
720p / 120fps

 CUSTOM	RESOLUCIÓN	NTSC (fps)	PAL (fps)	Campo de visión
	4K 2.7K 2.7K (4:3) 1440P 1080P 960P 720P	15 24/30 30 24/30 24/30/60 60 30/60/120	12.5 24/25 25 24/25 24/25/50 50 25/50/120	W : Ancho W/M : Ancho/Medio W : Ancho W : Ancho W/M/N : Ancho/Medio/Estrecho W : Ancho W/M/N : Ancho/Medio/Estrecho

MODOS DE FOTOGRAFÍA



Foto clásica
 16 MP, 12 MP, 8 MP, 5 MP



Fotos de ráfaga
 x30 fotos / 1s, 2s, 3s, 6s
 x10 fotos / 1s, 2s, 3s
 x5 fotos/s
 x3 fotos/s

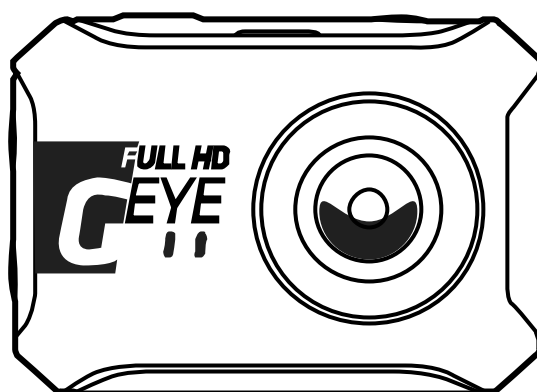
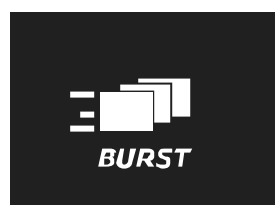
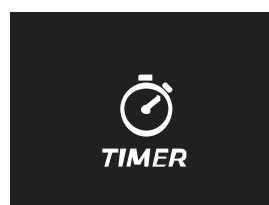

Temporizador
 1s, 3s, 5s, 10s, 30s



Foto a intervalos
 1 foto / 2s, 5s, 10s, 30s, 60s, 300s

AJUSTES GENERALES (1/3)

SONIDO
On
Off

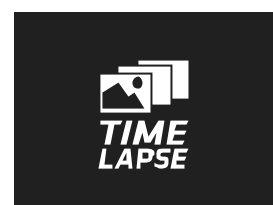
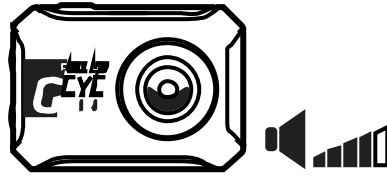

LEDS
On
Off

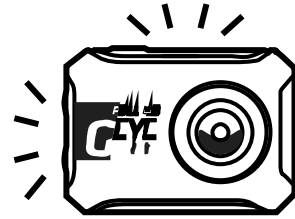

ROTAR
ARRIBA
BAJO
AUTO

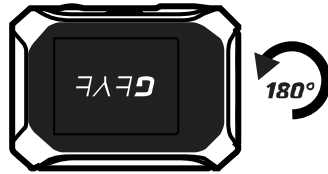

LCD
STANDBY
On
Off

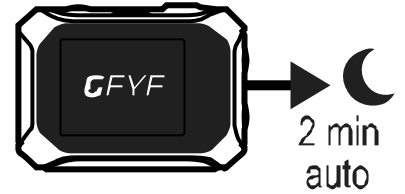

AUTO On/Off
On
Off

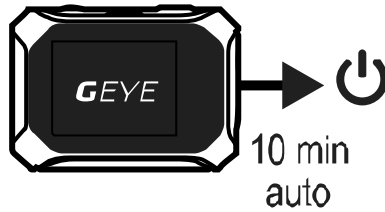

VISTA
On
Off

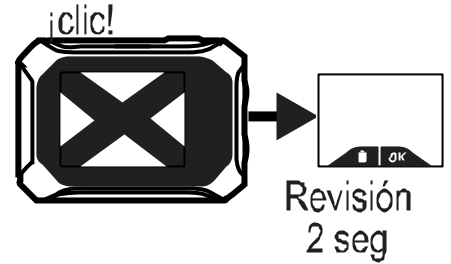

AJUSTES GENERALES (2/3)

ÚLTIMO MODO
On
Off

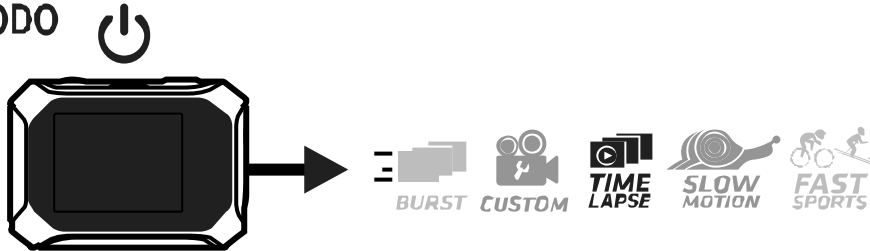

Activar la cámara en el último modo de vídeo/foto

FAST REC:
On
Off

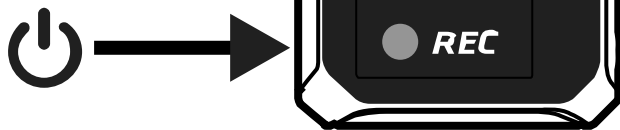

Activar la cámara e iniciar el vídeo/foto

PAUSAR
On
Off

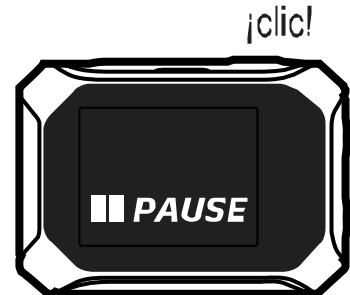

Activar la función de pausa de grabación

AJUSTES GENERALES (3/3)

DISTORSIÓN:

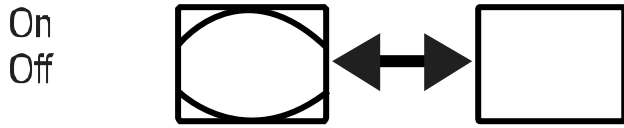

BUCLE

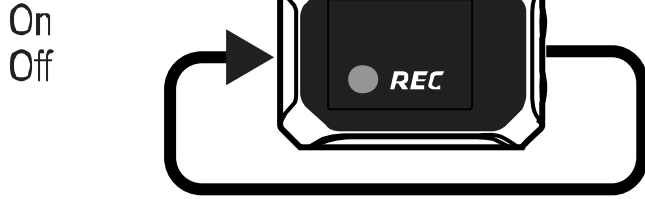

SALIDA

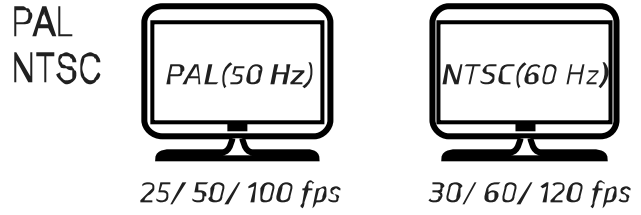

RESETEAR

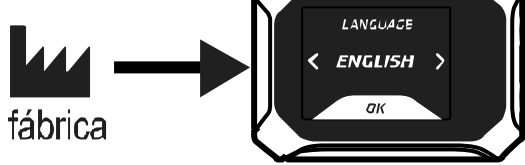

FORMATO SD

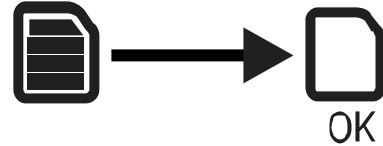

VER/CONTROL

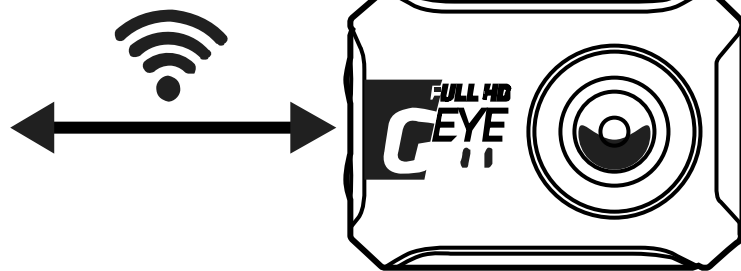

Ve, configura y controla la cámara a través del wifi de tu teléfono inteligente.

Activa el wifi de la cámara y de tu teléfono inteligente y sigue las instrucciones de la aplicación.

MANDO A DISTANCIA (OPCIONAL)

Empareja el mando a distancia siguiendo el procedimiento después de activar la función remota en los ajustes generales de la cámara.

ES

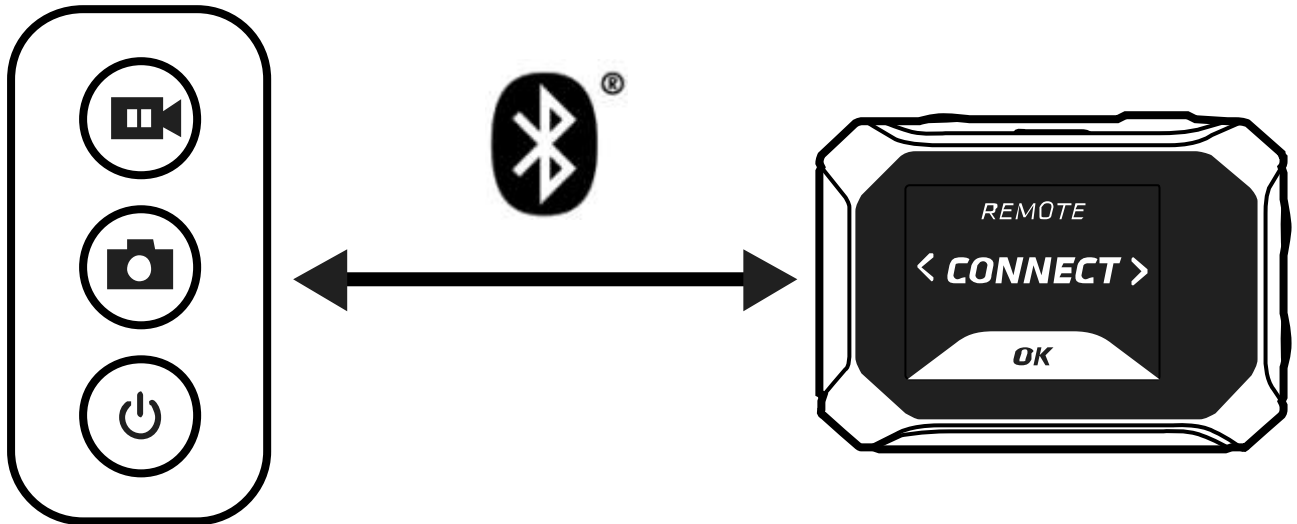

VER TELEVISIÓN

Con un cable mini-HDMI (opcional) puedes emitir el contenido de fotos/vídeos en un televisor de alta definición.

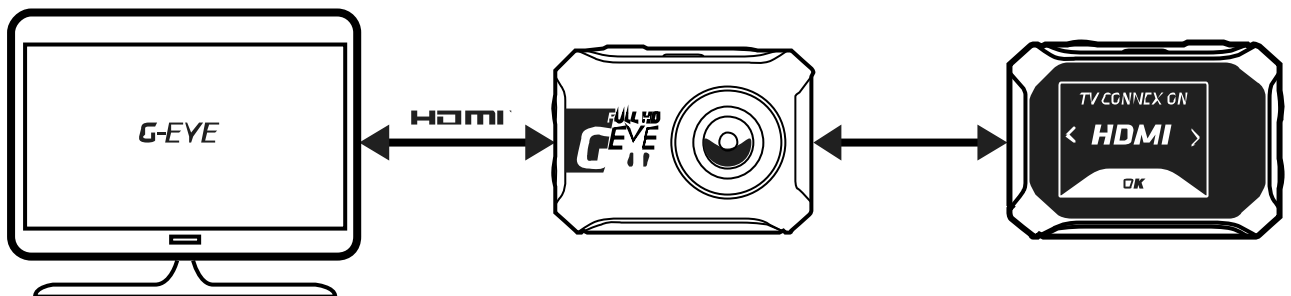

FIJAR LA CÁMARA

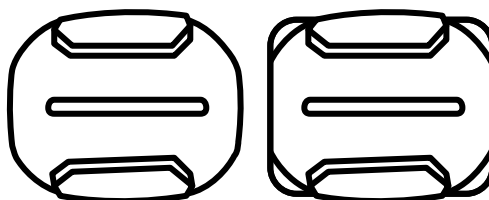

Los soportes adhesivos solo se deben fijar en superficies lisas y limpias a temperatura ambiente.

Espera 24 horas antes de su uso.

ESPECIFICACIONES TÉCNICAS

Peso y dimensiones de la GEYE900:

Peso: 106 g/207 g con caja

Altura: 50 mm

Anchura: 68 mm

Profundidad: 27 mm / 36 mm con lente

Tipo de batería de la GEYE900:

Batería de li-ion, 1480 mAh

Material principal: ABS

SEGURIDAD GENERAL DEL PRODUCTO

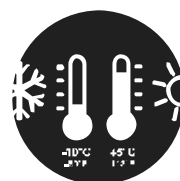

Trata el dispositivo con cuidado, no lo dejes caer ni lo expongas a impactos fuertes.

Atención, este producto no es resistente al agua sin su caja estanca. No lo expongas al agua ni lo sumerjas

Para mayor seguridad, no toques los botones mientras está en uso. La pérdida de concentración puede ser peligrosa

No desmontes este producto, ya que esto podrías dañarlo y perder la garantía

El uso de este dispositivo en frío extremo (a temperatura por debajo de -10°C) puede disminuir la capacidad de la batería y por lo tanto reducir la duración de la misma)

RESPONSABILIDAD LIMITADA

DECATHLON no es responsable de los accidentes o lesiones que resulten de la manipulación o el uso de este producto en deportes de alto riesgo. En concreto, DECATHLON desea informar al usuario sobre el posible riesgo de perder la concentración debido a la manipulación del producto en situación peligrosas.

Se advierte al usuario que asume toda la responsabilidad legal por las fotos tomadas y por el intercambio y la publicación de las imágenes capturadas con este producto.

DECLARACIÓN DE CONFORMIDAD CE

DECATHLON declara que el dispositivo G-EYE 900 cumple con los requisitos esenciales y otras disposiciones relevantes de la Directiva 2014/53/CE.

La declaración de conformidad CE está disponible en el siguiente enlace web:
www.geonaute.com/en/ec-declaration-conformity

ES

RECICLAJE



CONTÁCTANOS

Contacta con nosotros en
www.customercare.geonaute.com

BESCHREIBUNG



kurzer Druck:
Startet/Setzt Video auf Pause

langer Druck:
Schaltet die Kamera ein und startet die Aufzeichnung/ stoppt die Aufzeichnung



kurzer Druck:
Schießt ein Foto / Schießt ein Foto im Video

langer Druck:
Schaltet die Kamera ein und schießt ein Foto



langer Druck:
On/Off



langer Druck:
WIFI On/Off

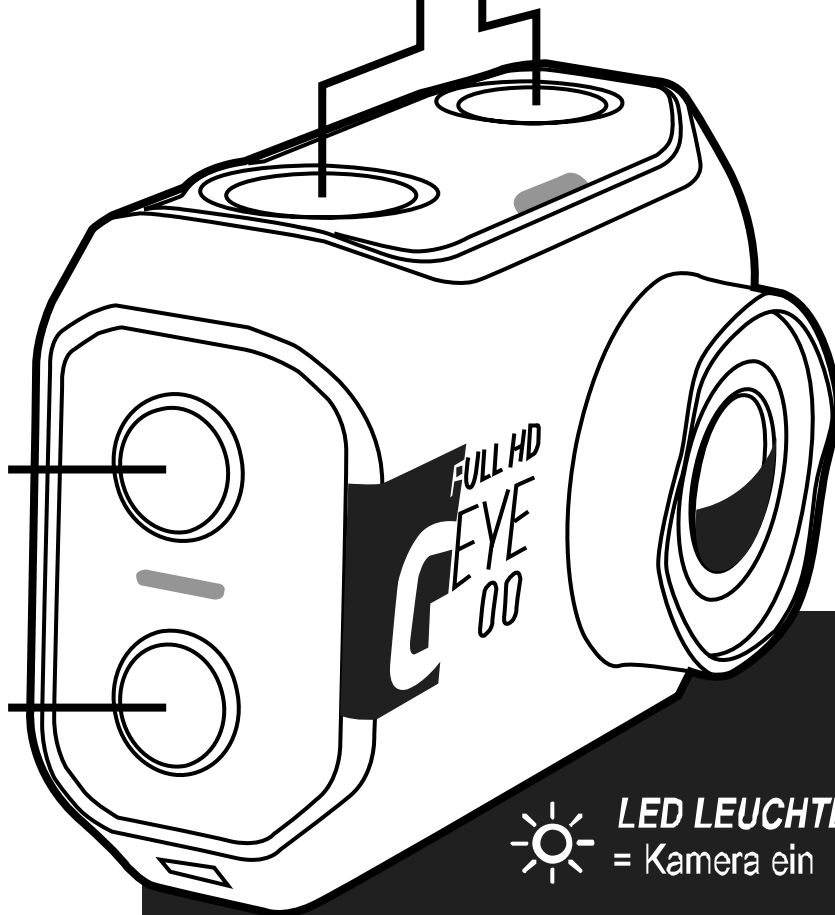

 **LED LEUCHTET GRÜN**
= Kamera ein

 **LED LEUCHTET ROT**
= Video auf Pause oder Kamera lädt.

LED BLINKT ROT
= Photo oder Videoaufnahme im Gange oder Batterie schwach.

ERSTE SCHRITTE

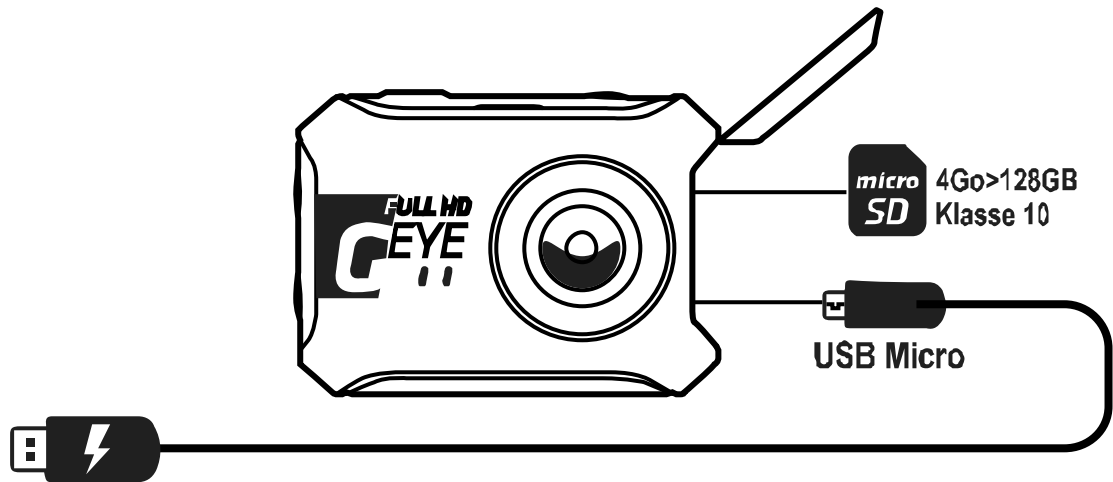

DE

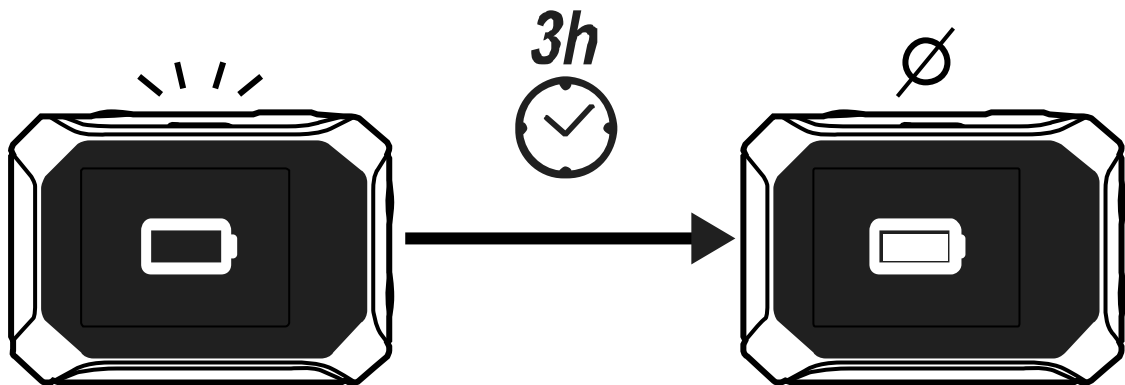

VERWENDUNG MIT DICHTEM GEHÄUSE

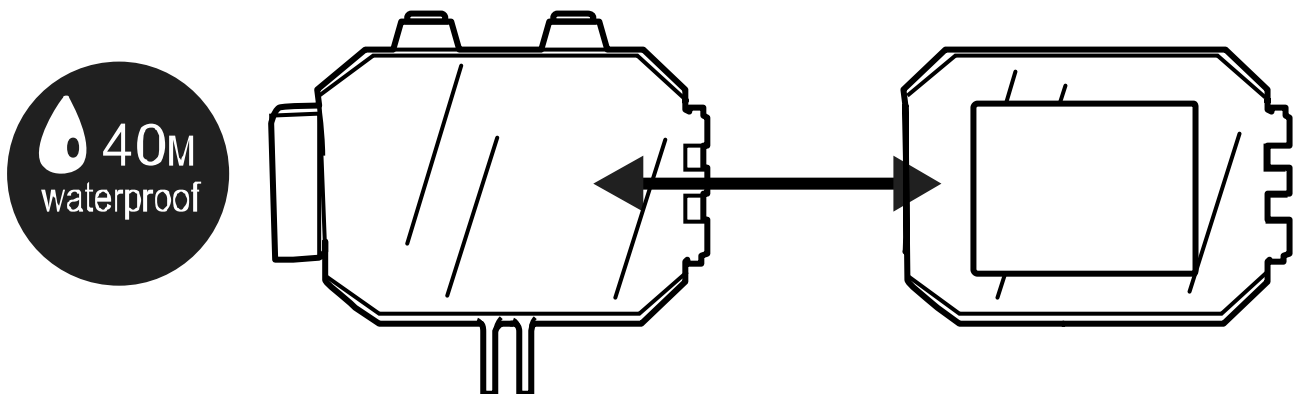

- Hintere Tür, Standard (voll): Dichtigkeit bis zu 40m
Um eine vollkommene Dichtigkeit zu gewährleisten, muss die Dichtung sauber gehalten werden.
Mit klarem Wasser spülen.
- Hintere Tür, durchbrochen : für trockenere und staubfreie Umgebungen :
Zugriff zum Tastbildschirm und bessere Tonaufnahme.

WECHSEL DER HINTEREN TÜR:

Das Gehäuse ganz öffnen und seitlich an der Tür ziehen, bis sie aufspringt.

Die neue Tür am Scharnier ausrichten und schließen, bis sie sich vollkommen einklinkt.



Einen Beschlagschutz verwenden (bei DECATHLON separat verkauftes Zubehör)

MENÜ

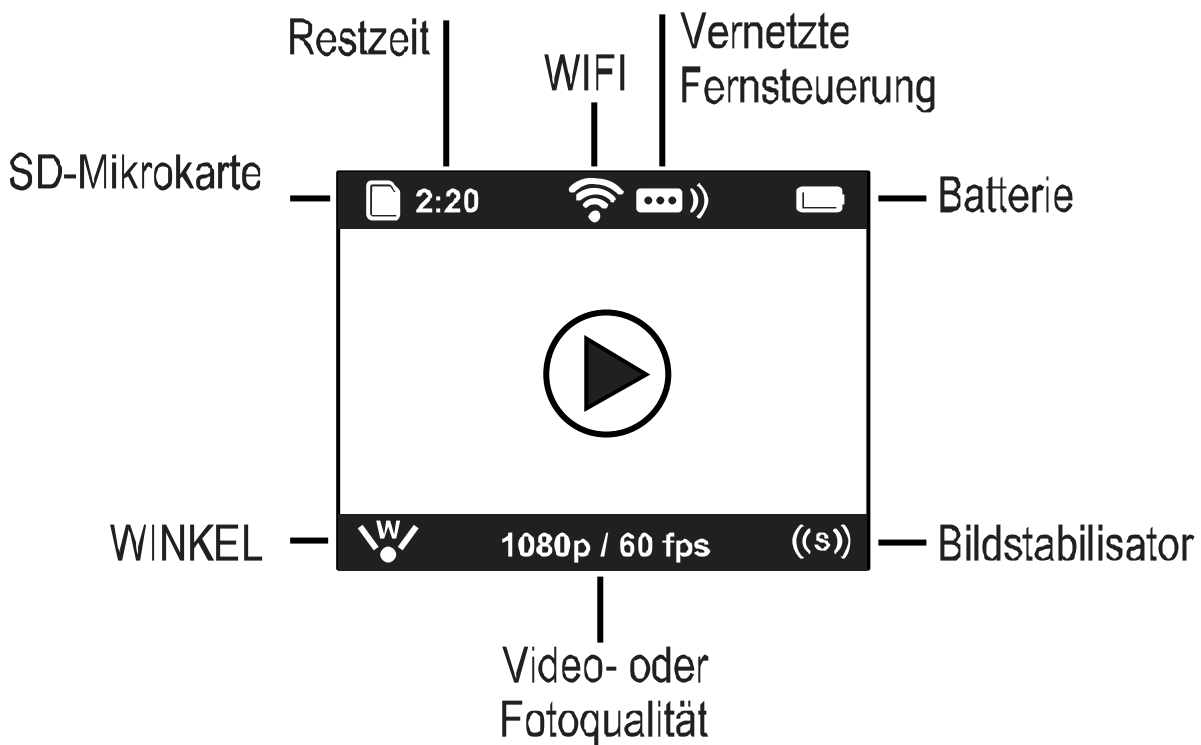

MENÜ

HAUPTPARAMETER

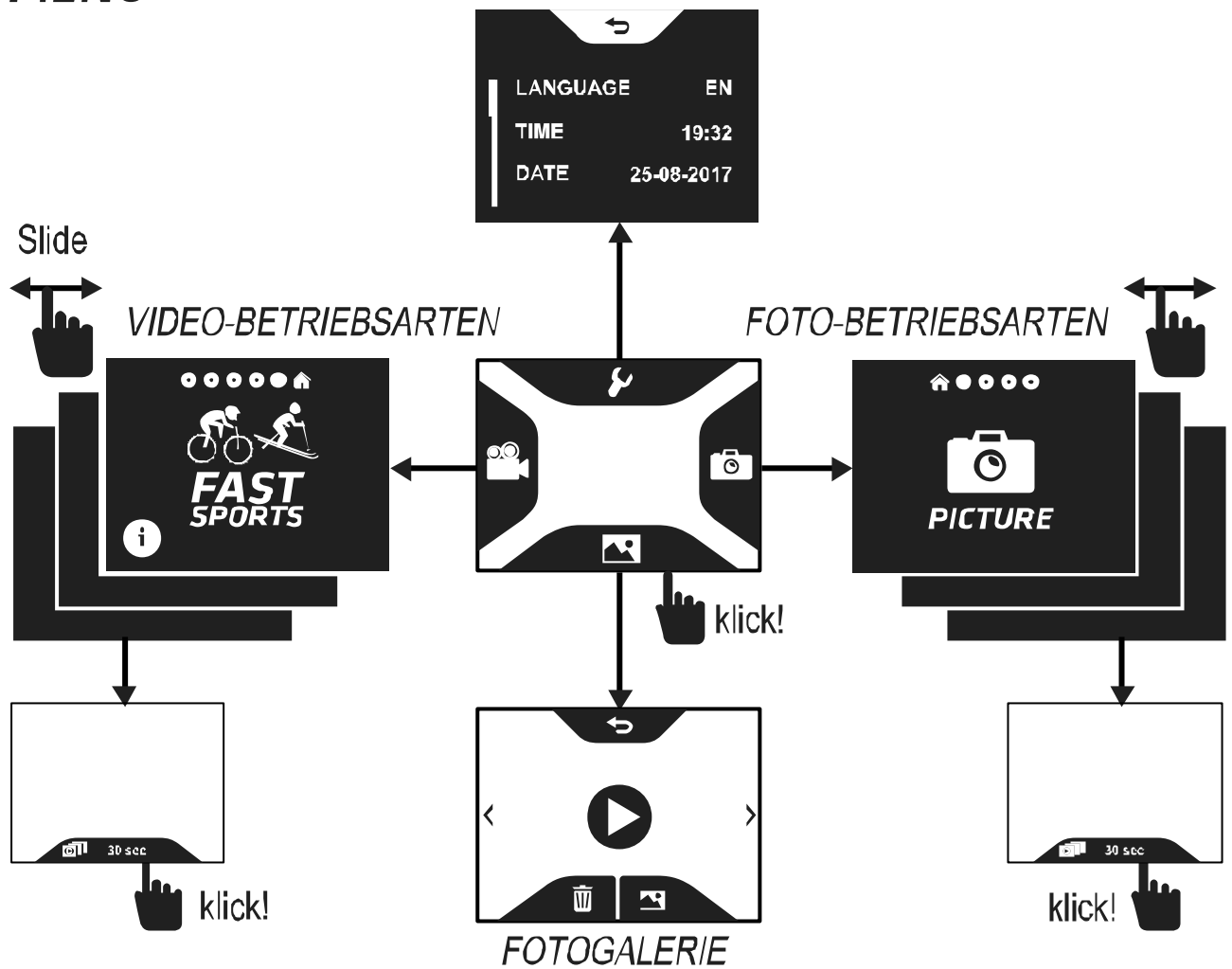

DE

VIDEO-BETRIEBSARTEN



Optimierte
Einstellungen
für dynamische
Sportarten
1080p (Full HD)
60fps
Weitwinkel und
Stabilisator



Optimierte
Einstellungen für
langsame Sportarten
1080p (Full HD)
30fps
Weitwinkel

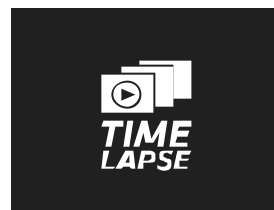

Zeitraffer Video
1 Foto / 2s, 5s, 10s,
30s, 60s, 300s



Zeitlupe Video
720p / 120fps

 CUSTOM	AUFLÖ- SUNG	NTSC (fps)	PAL (fps)	Blickfeld
	4K 2.7K 2.7K (4:3) 1440P 1080P 960P 720P	15 24/30 30 24/30 24/30/60 60 30/60/120	12.5 24/25 25 24/25 24/25/50 50 25/50/120	W : Weit W/M : Weit/Mittel W : Weit W : Weit W/M/N : Weit/Mittel/Eng W : Weit W/M/N : Weit/Mittel/Eng

FOTO-BETRIEBSARTEN



Klassisches Foto
 16 MP, 12 MP, 8
 MP, 5 MP

Serienfotos
 x30 Bilder / 1s, 2s,
 3s, 6s
 x10 Bilder / 1s,
 2s, 3s
 x5 Bilder/s
 x3 Bilder/s

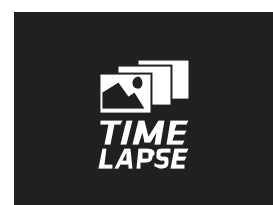
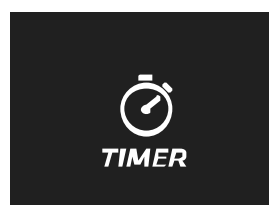
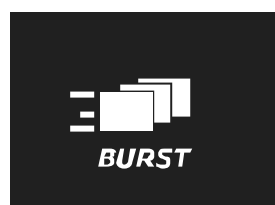
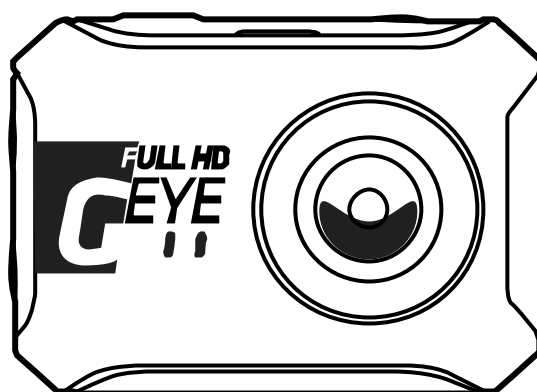
Selbstausröser
 1s, 3s, 5s, 10s, 30s

Zeitraffer Foto
 1 Foto / 2s, 5s, 10s,
 30s, 60s, 300s

ALLGEMEINE PARAMETER (1/3)

TON
On
Off

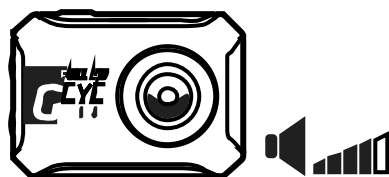

LEDS
On
Off

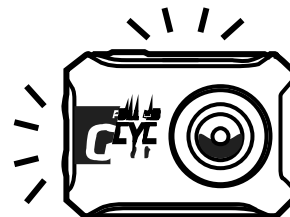

DE

DREHEN
AUF
AB
AUTO



LCD
STANDBY
On
Off

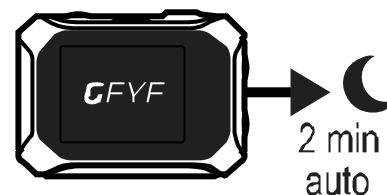

AUTO On/
Off
On
Off

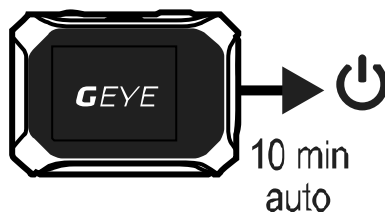

ABSPIELEN
On
Off

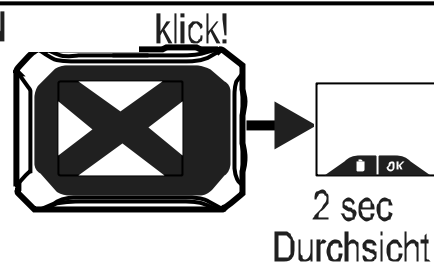

ALLGEMEINE PARAMETER (2/3)

LETZT. MODUS
On
Off

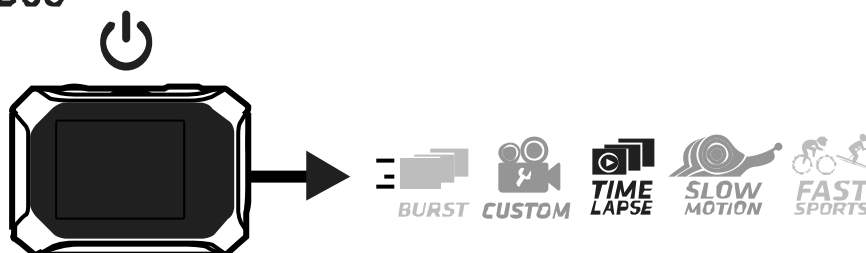

Aktiviert die Kamera nach der letzten Betriebsart Video/Foto

FAST REC:

On
Off

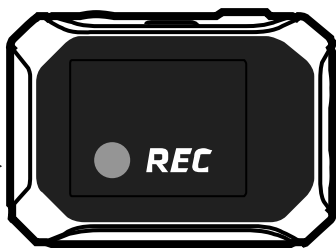

Aktiviert die Kamera und startet die Video/Foto-Aufnahme

ANHALTEN

On
Off

klick!

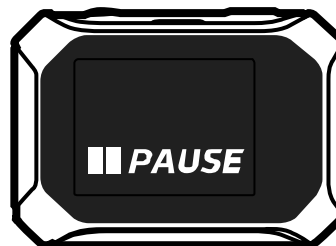

Aktiviert die Pausenfunktion bei der Aufzeichnung

ALLGEMEINE PARAMETER (3/3)

VERZERRUNG:

On
Off

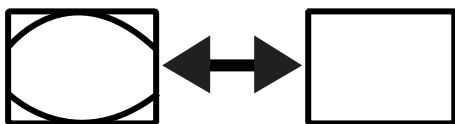

LOOP VIDEO

On
Off

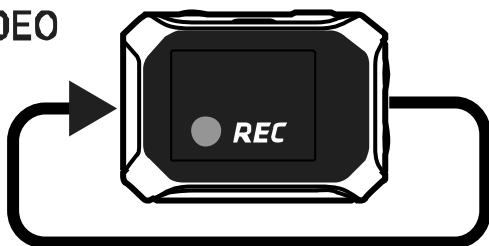

OUTPUT

PAL
NTSC

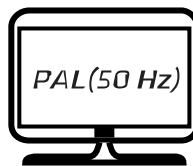

25/ 50/ 100 fps



30/ 60/ 120 fps

ALLES ZURÜCKSETZEN

Factory



SD-FORMAT



Ok!

ANZEIGEN / STEUERN

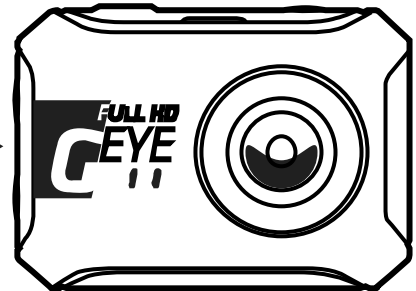

DE

Über das WLAN Ihres Smartphones die Kamera anzeigen, parametrieren und steuern.

Das WLAN Ihrer Kamera und Ihres Smartphones aktivieren, dann die Anweisungen der App befolgen.

FERNSTEUERUNG (OPTION)

Nach Aktivierung der REMOTE-Funktion unter den allgemeinen Parametern der Kamera die Fernbedienung wie angegeben verbinden (Pairing).

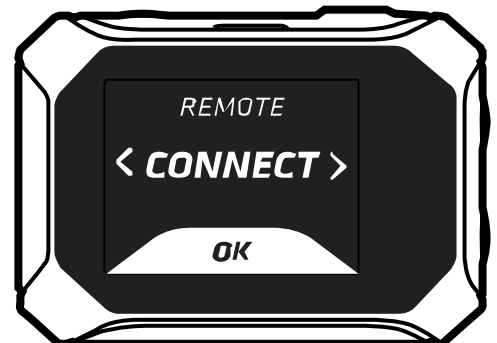
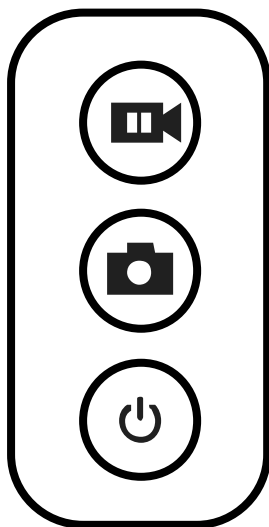

TV-WIEDERGABE

Mithilfe eines HDMI-Minikabels (Option) können Sie Ihren Foto-/Videoinhalt auf einem HD-Fernsehgerät wiedergeben.

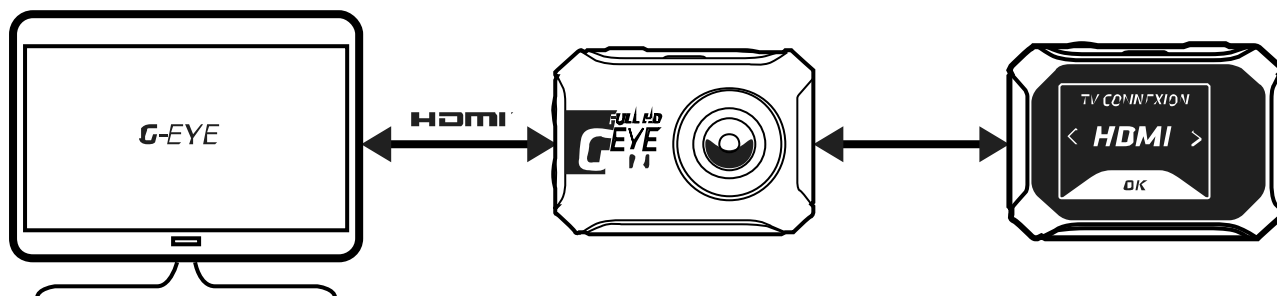

DIE KAMERA BEFESTIGEN

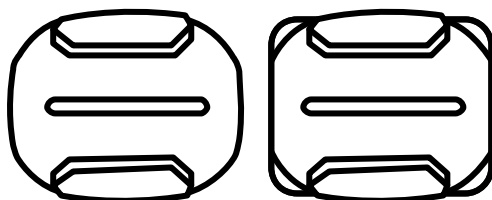

Die Klebehalter auf sauberen und glatten Oberflächen befestigen, nur bei Raumtemperatur.

Vor dem Gebrauch 24 Stunden warten.

TECHNISCHE DATEN

Gewicht & Abmessung GEYE900:

Gewicht: 106g / 207g w Gehäuse

Höhe: 50mm

Breite: 68mm

Tiefe: 27mm / 36mm mit Linsen

Batterietyp GEYE900:

Li-Ion-Batterie, 1480mAh

Hauptmaterial: ABS

ALLGEMEINE PRODUKTSICHERHEIT



Das Gerät sorgfältig handhaben, nicht fallen lassen oder Stößen aussetzen
Vorsicht, dieses Produkt ist ohne die Wasserschutzhülle nicht wasserdicht. Nicht dem Wasser aussetzen oder eintauchen

Aus Sicherheitsgründen während des Gebrauchs nicht die Knöpfe berühren. Es kann gefährlich sein, die Konzentration zu verlieren

Das Gerät nicht auseinandernehmen; es könnte Schaden nehmen und die Garantie aufheben

Der Gebrauch des Gerätes bei großer Kälte (Temperaturen unter -10°) kann die Batteriekapazität beeinträchtigen und somit die Lebensdauer des Produkts reduzieren

BESCHRÄNKTE HAFTUNG

DECATHLON haftet nicht für Unfälle oder Verletzungen, die aus der Handhabung oder dem Gebrauch dieses Produkts bei Teilnahme an Hochrisikosportarten resultieren. DECATHLON weist den Nutzer insbesondere auf das Risiko eines Konzentrationsverlusts durch die Handhabung des Produkts unter gefährlichen Bedingungen hin.

Warnhinweis: der Nutzer trägt die gesetzliche Haftung für das Schießen, die Weitergabe und die Veröffentlichung von mit diesem Produkt gemachten Bildern.

EC-KONFORMITÄTSERKLÄRUNG

DECATHLON erklärt hiermit, dass das G-EYE 900-Gerät die wesentlichen Anforderungen und sonstige wichtige Bestimmungen der EU-Richtlinie 2014/53/EU erfüllt.

Die EC-Konformitätserklärung ist unter dem nachstehenden Weblink erhältlich:
www.geonaute.com/en/ec-declaration-conformity

RECYCLING

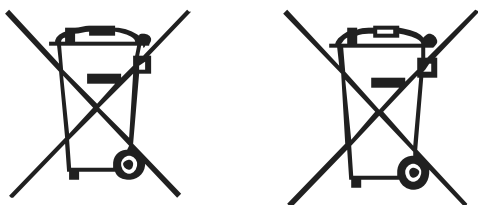

KONTAKTIEREN SIE UNS

Kontaktieren Sie uns unter
www.customercare.geonaute.com

DESCRIZIONE



pressione breve:
Avvio/Messa in pausa del video

pressione lunga:
Accensione videocamera e avvio registrazione / arresto registrazione



pressione breve:
Scatto foto / Scatto foto nel video

pressione lunga:
Accensione videocamera e scatto foto



pressione lunga:
On/Off



pressione lunga:
WIFI On/Off

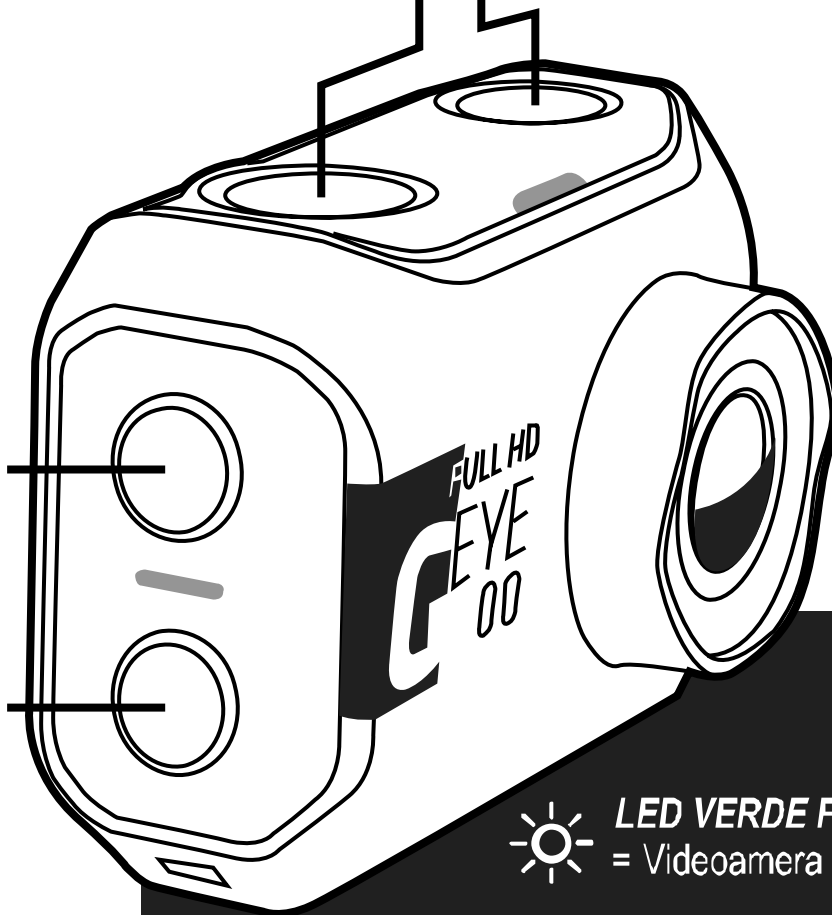

LED VERDE FISSO

= Videocamera on



LED ROSSO FISSO

= Video in pausa o videocamera in ricarica.

LED ROSSO LAMPEGGIANTE

= Foto o registrazione video in corso o batteria quasi scarica.

PRIMI PASSI

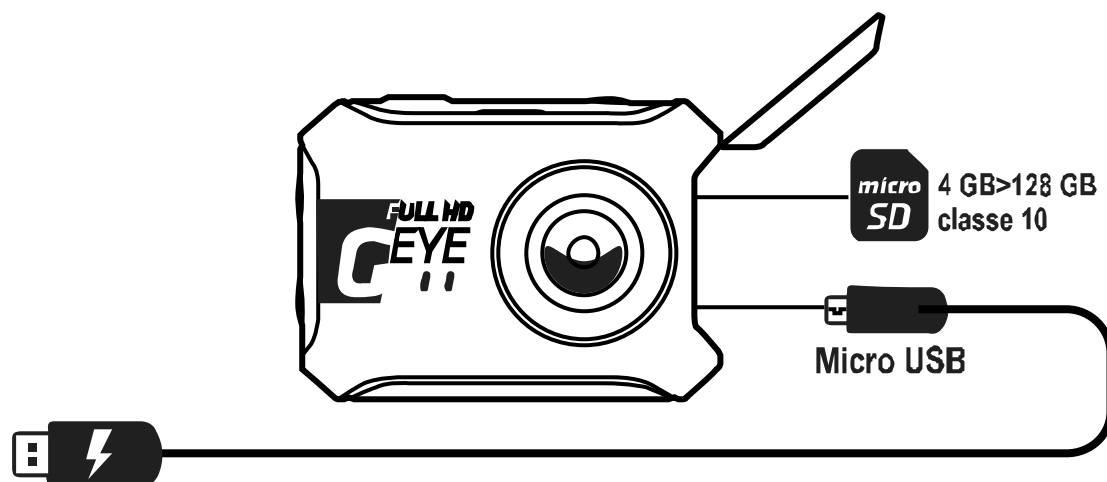

IT

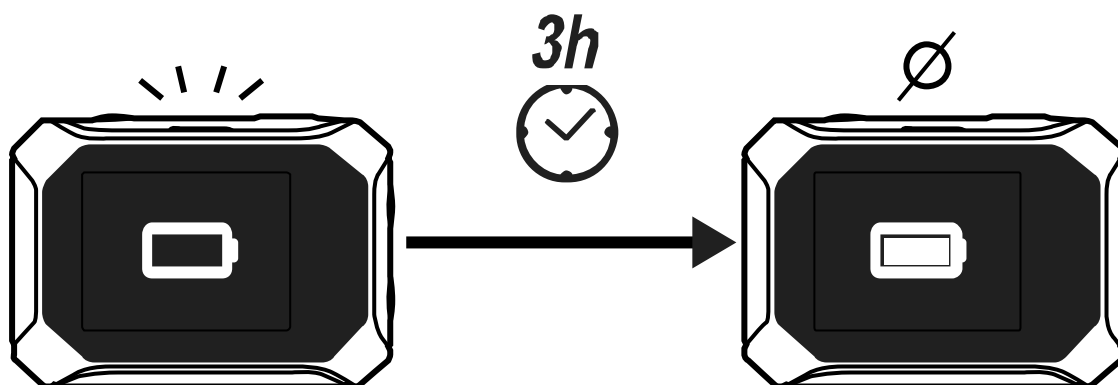

UTILIZZO CON CUSTODIA SUB

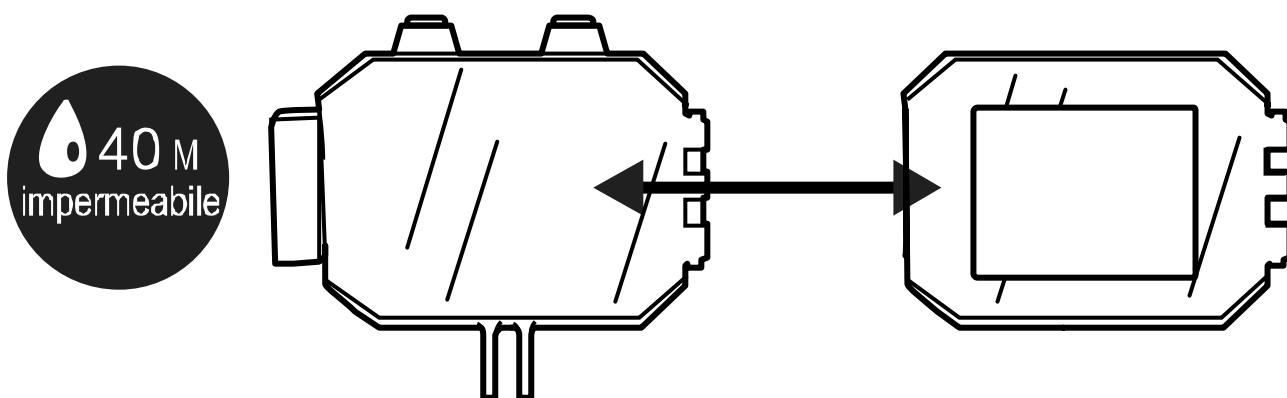

- Portello posteriore standard (pieno): impermeabile fino a 40 m
Per garantire una perfetta tenuta stagna, è importante tenere pulita la guarnizione di tenuta.
Lavare con acqua pulita.
- Portello posteriore perforato: per ambienti secchi e senza polvere:-
accesso al touchscreen e registrazione audio più efficiente.

SOSTITUZIONE PORTELLO POSTERIORE:

Aprire completamente la custodia, tirare il portello lateralmente fino a sfilarlo.
Allineare il nuovo portello con la cerniera e chiuderlo fino a incastrarlo perfettamente.



Utilizzare un antiappannante (accessorio venduto a parte da DECATHLON)

MENU

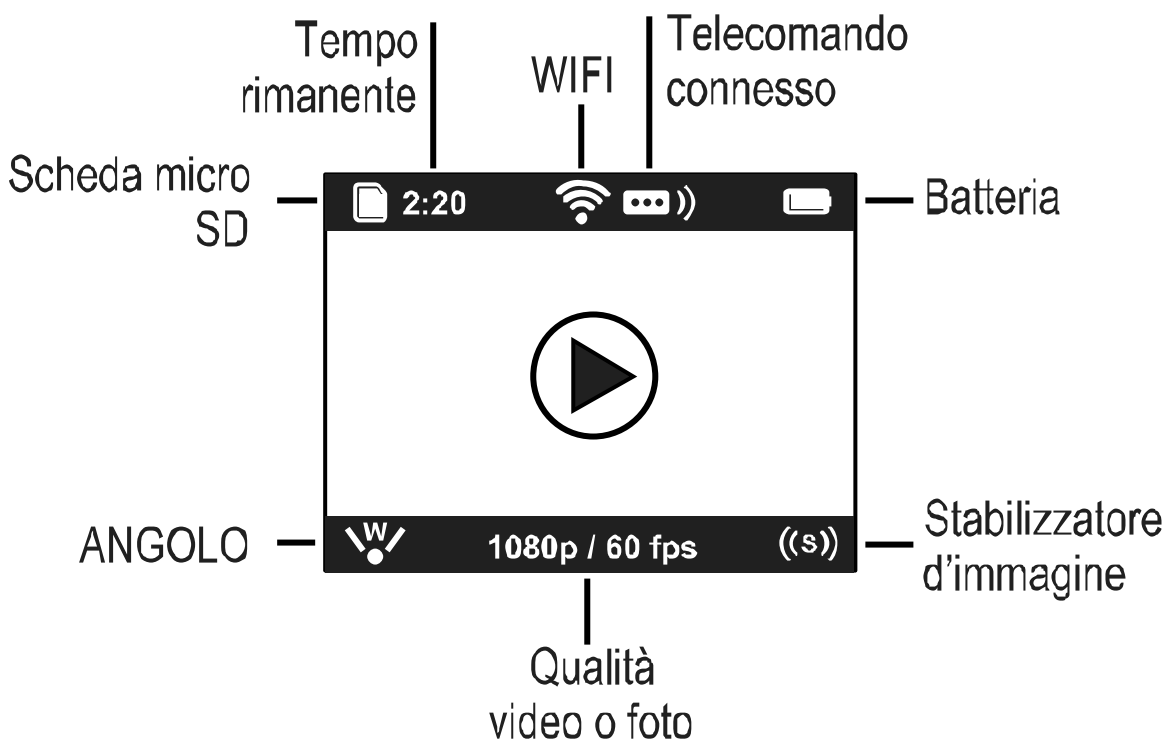

MENU

PARAMETRI GENERALI

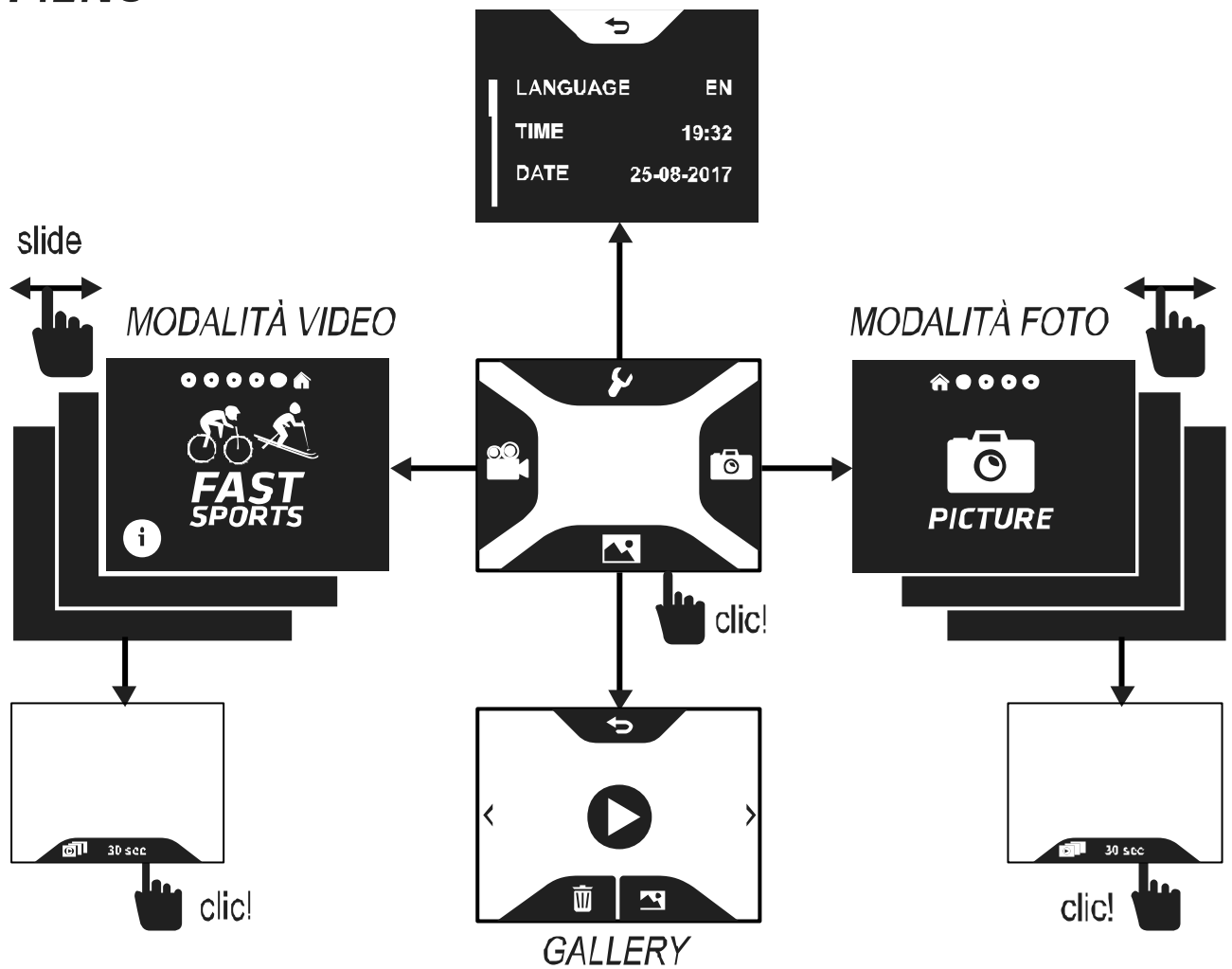

IT

MODALITÀ VIDEO



Impostazioni ottimizzate per sport dinamici
1080p (Full HD)
60 fps
grandangolo e stabilizzatore



Impostazioni ottimizzate per sport lenti
1080p (Full HD)
30 fps
grandangolo

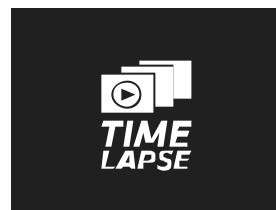

Video in timelapse
1 foto / 2 s, 5 s, 10 s, 30 s, 60 s, 300 s



Rallentatore video
720p / 120 fps

 CUSTOM	RISOLUZIONE	NTSC (fps)	PAL (fps)	Angolo di campo
	4K 2.7K 2.7K (4:3) 1440P 1080P 960P 720P	15 24/30 30 24/30 24/30/60 60 30/60/120	12.5 24/25 25 24/25 24/25/50 50 25/50/120	W : Ampio W/M : Ampio/Medio W : Ampio W : Ampio W/M/N : Ampio/Medio/Stretto W : Ampio W/M/N : Ampio/Medio/Stretto

MODALITÀ FOTO



Foto classica
16 MP, 12 MP, 8 MP, 5 MP



Foto a raffica
x30 fotogrammi / 1s, 2s, 3s, 6s
x10 fotogrammi / 1s, 2s, 3s
x5 fotogrammi/s
x3 fotogrammi/s

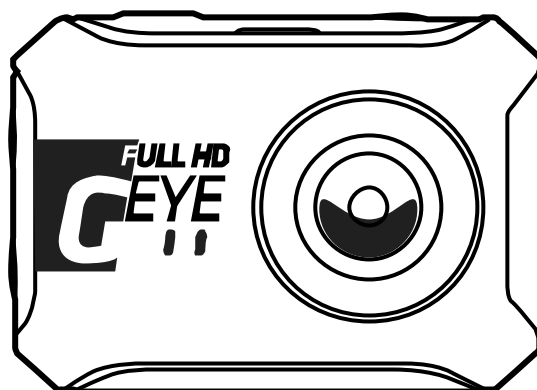

Autoscatto
1s, 3s, 5s, 10s, 30s

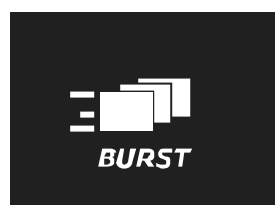
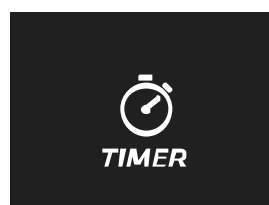

Foto in timelapse
1 foto / 2s, 5s, 10s, 30s, 60s, 300s

PARAMETRI GENERALI (1/3)

SUONO
On
Off

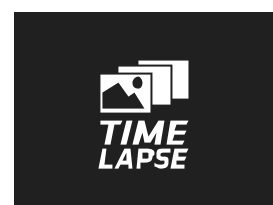

LEDS
On
Off

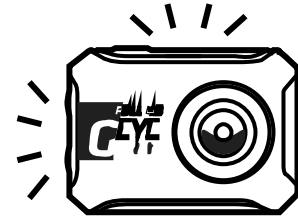

IT

RUOTA
SU
GIÙ
AUTO

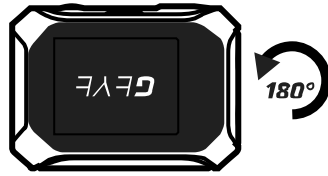

**LCD
STANDBY**
On
Off

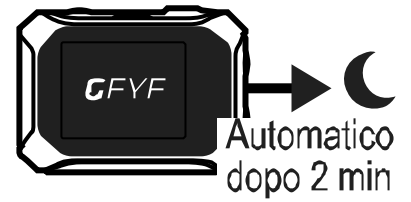

AUTO On/Off
On
Off

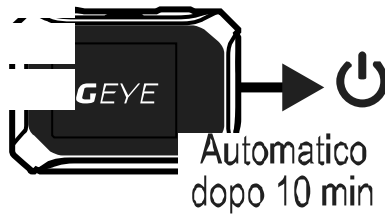

RILETTURA
On
Off

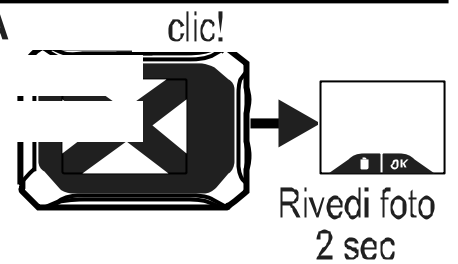

PARAMETRI GENERALI (2/3)

ULTIMO MODO
On
Off

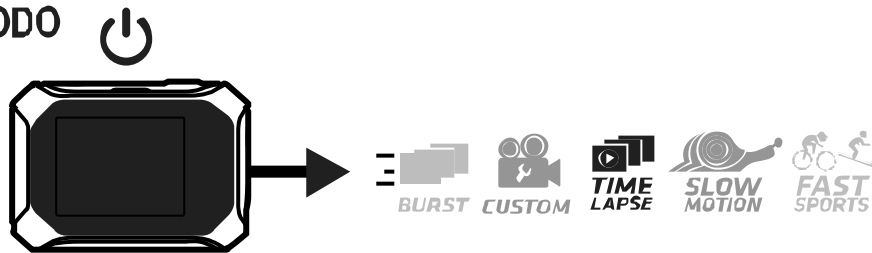

Attiva la videocamera con l'ultima modalità video/foto

FAST REC:

On
Off



Attiva la videocamera e avvia video/foto

PAUSA

On
Off

clic!

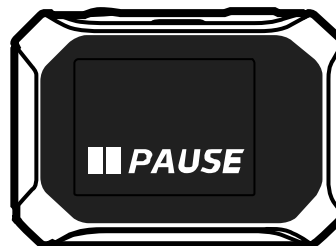

Attiva la funzione pausa registrazione

PARAMETRI GENERALI (3/3)

DISTORSIONE:

On
Off

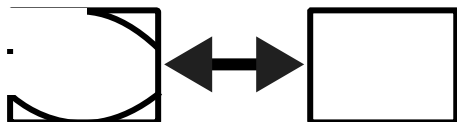

LOOP VIDEO

On
Off

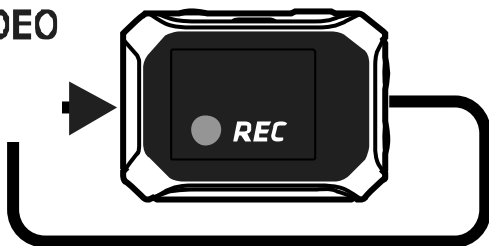

USCITA

PAL
NTSC



25/ 50/ 100 fps



30/ 60/ 120 fps

AZZERA TUTTO



impostazioni fabbrica

FORMATTA SD

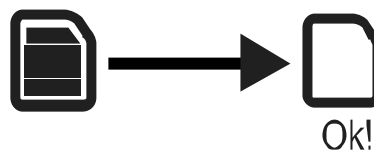

VISUALIZZA / PILOTA

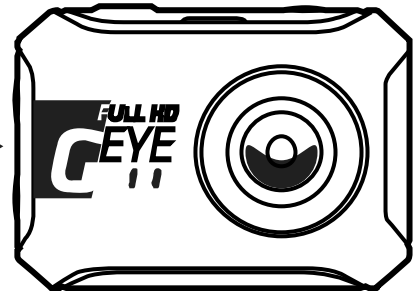

IT

Visualizzare, regolare e pilotare la videocamera tramite il wifi dello smartphone.

Attivare il wifi della videocamera e dello smartphone poi seguire le istruzioni dell'applicazione.

TELECOMANDO (OPZIONALE)

Accoppiare il telecomando seguendo la procedura dopo avere attivato la funzione REMOTE nei parametri generali della videocamera.

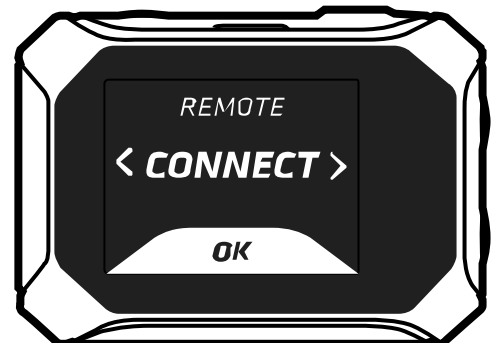
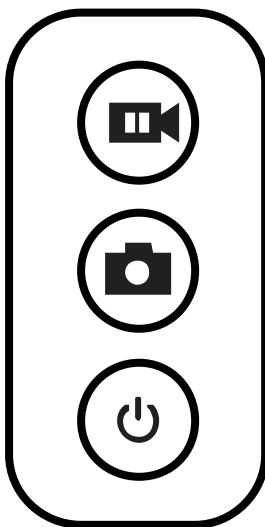

VISUALIZZAZIONE TV

Si possono visualizzare i contenuti foto/video su un televisore HD tramite un cavo mini-HDMI (opzionale).

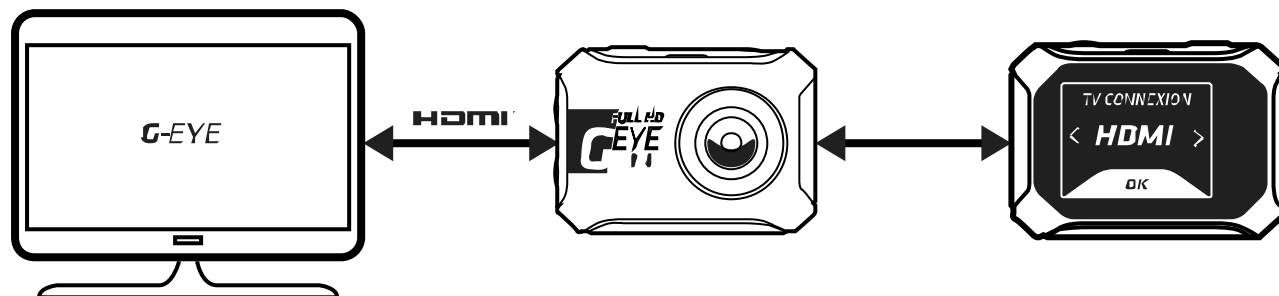

FISSARE LA VIDEOCAMERA

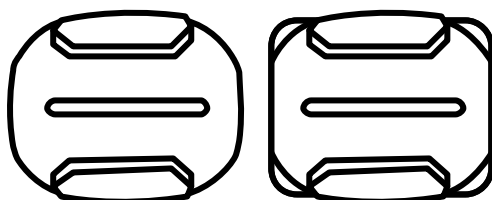

Fissare i supporti adesivi solo su superfici pulite e lisce a temperatura ambiente. Attendere 24 ore prima di utilizzare.

SPECIFICHE TECNICHE

Peso e dimensioni GEYE900:

Peso: 106 g / 207 g con custodia

Altezza: 50 mm

Larghezza: 68mm

Profondità: 27 mm / 36 mm con obiettivo

Tipo batteria GEYE900:

Batteria Li-ion, 1480 mAh

Materiale principale: ABS

SICUREZZA GENERALE DEL PRODOTTO



Maneggiare il dispositivo con cautela, non lasciarlo cadere e non esporlo a forti urti»
Attenzione: questo prodotto non è impermeabile senza la sua custodia sub. Non esporlo

all'acqua e non immergerlo

Per una maggiore sicurezza, non toccare i pulsanti durante l'uso. La distrazione potrebbe essere pericolosa

Non smontare questo prodotto: si potrebbe danneggiare e la garanzia sarebbe annullata

L'uso del dispositivo con freddo estremo (a temperature sotto i -10°C) potrebbe ridurre la capacità e quindi la durata della batteria

IT

RESPONSABILITÀ LIMITATA

DECATHLON non è responsabile degli incidenti o lesioni derivanti da manipolazione o uso di questo prodotto durante la partecipazione a sport estremi. In particolare, DECATHLON desidera informare l'utente del possibile rischio di distrazione a causa della manipolazione del prodotto in situazioni pericolose.

L'utente è avvisato del fatto che si assume tutte le responsabilità legali per la ripresa, la condivisione e la pubblicazione di immagini riprese con questo prodotto.

DICHIARAZIONE DI CONFORMITÀ EC

DECATHLON qui dichiara che il dispositivo G-EYE 900 è conforme ai requisiti essenziali e alle altre disposizioni pertinenti della direttiva 2014/53/EU.

La dichiarazione di conformità EC è disponibile al seguente link web:

www.geonaute.com/en/ec-declaration-conformity

RICICLAGGIO

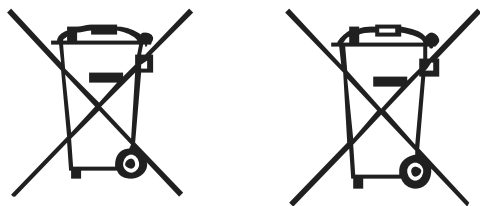

CONTATTI

Contattateci a

www.customercare.geonaute.com

BESCHRIJVING



kort indrukken:

De video starten / pauzeren

kort indrukken:

Een foto maken / Een foto maken tijdens de video

lang indrukken:

De camera aanzetten en de opname starten / opname stoppen

lang indrukken:

De camera aanzetten en een foto maken



lang

indrukken:
On/Off



lang

indrukken:
WIFI On/Off

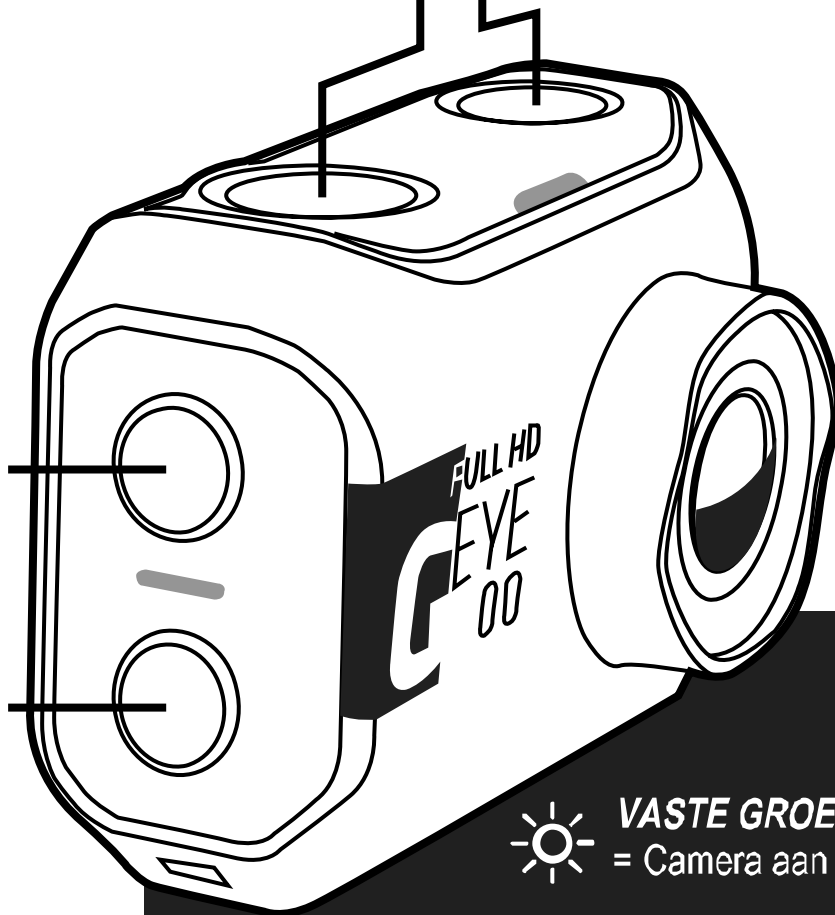

VASTE GROENE LED

= Camera aan



VASTE RODE LED

= Video op pauze of camera wordt geladen.

ROOD LED KNIPPERLICHT

= Foto- of video-opname wordt gemaakt of batterij bijna leeg.

EERSTE STAPPEN

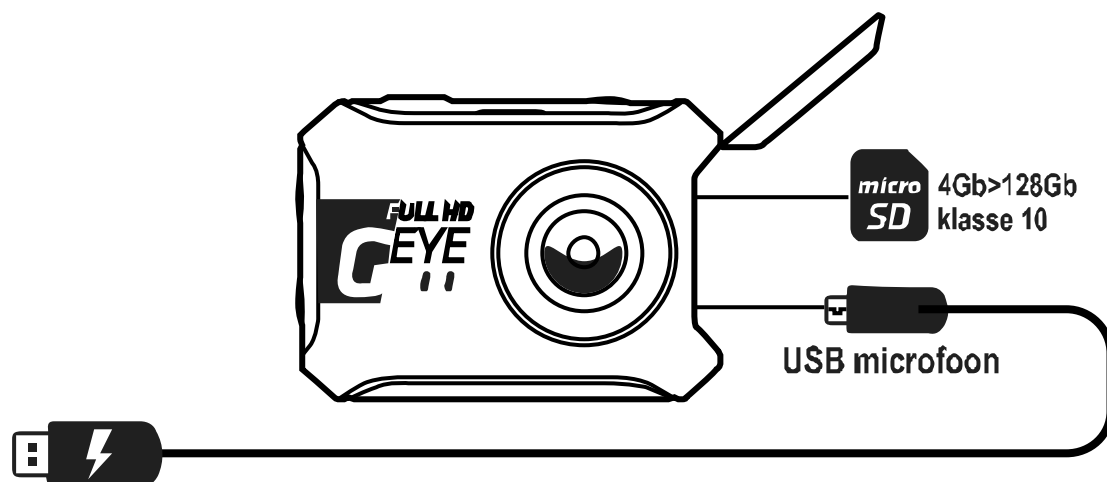

NL

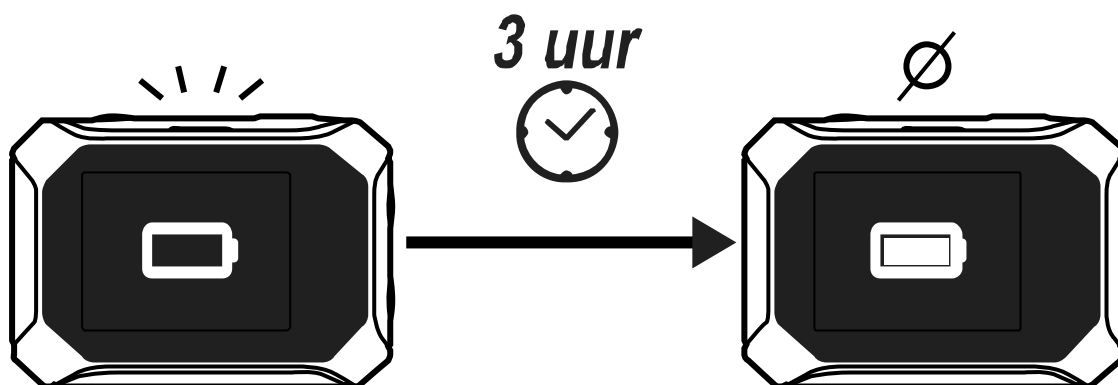

GEBRUIK MET WATERDICHTE BOX

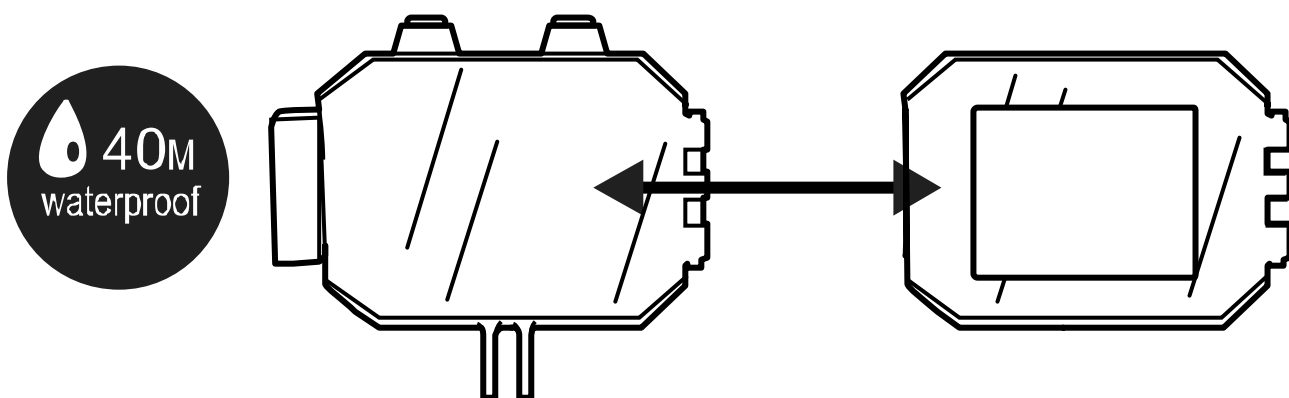

- Standaard achterdeur (massief): waterdicht tot maximaal 40 m
Voor een perfecte waterdichtheid is het belangrijk de afdichting schoon te houden.
Spoelen met stromend water.
- Standaard achterdeur met lichtopening: voor in een droge stofvrije omgeving;
toegang tot touchscreen en krachtigere geluidsopname.

VERVANGING VAN DE ACHTERDEUR:

Open de box volledig, trek de deur naar de zijkant totdat hij loskomt.

De nieuwe deur uitlijnen met het scharnier en weer dicht doen totdat hij perfect past.



Maak gebruik van een anticondensapparaat (accessoire afzonderlijk verkocht door DECATHLON)

MENU

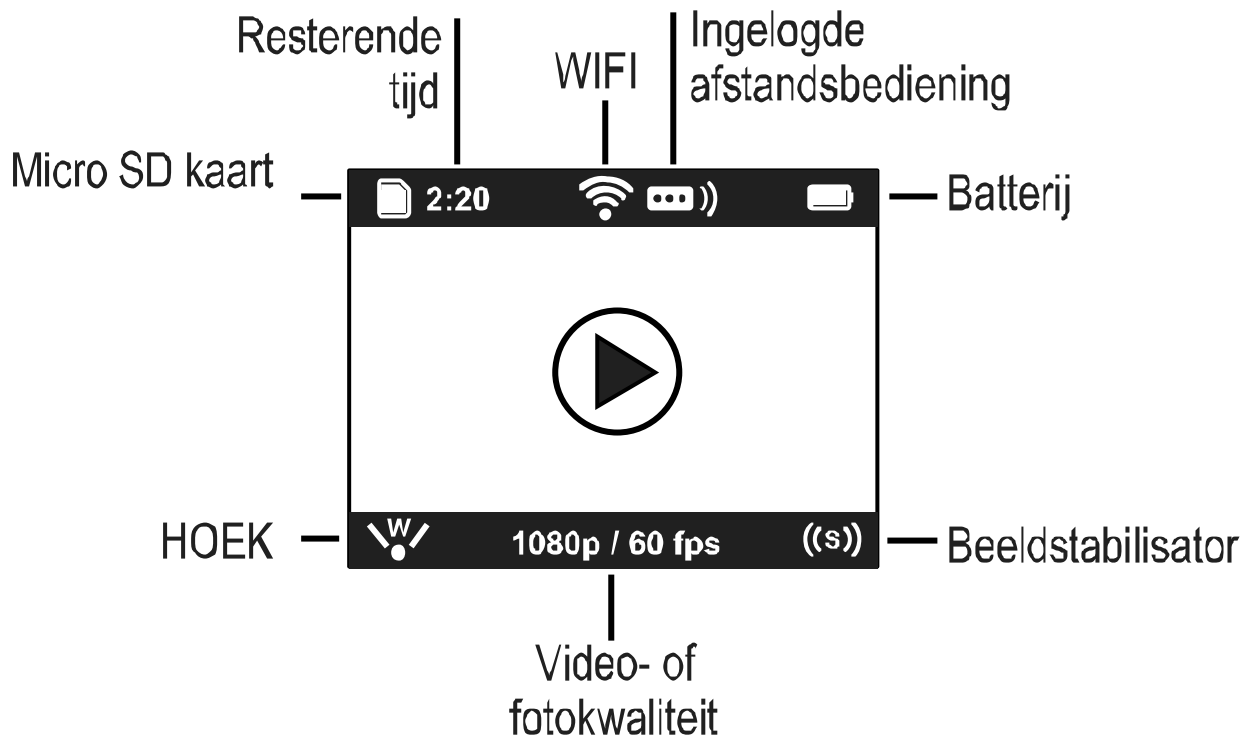

MENU

ALGEMENE INSTELLINGEN

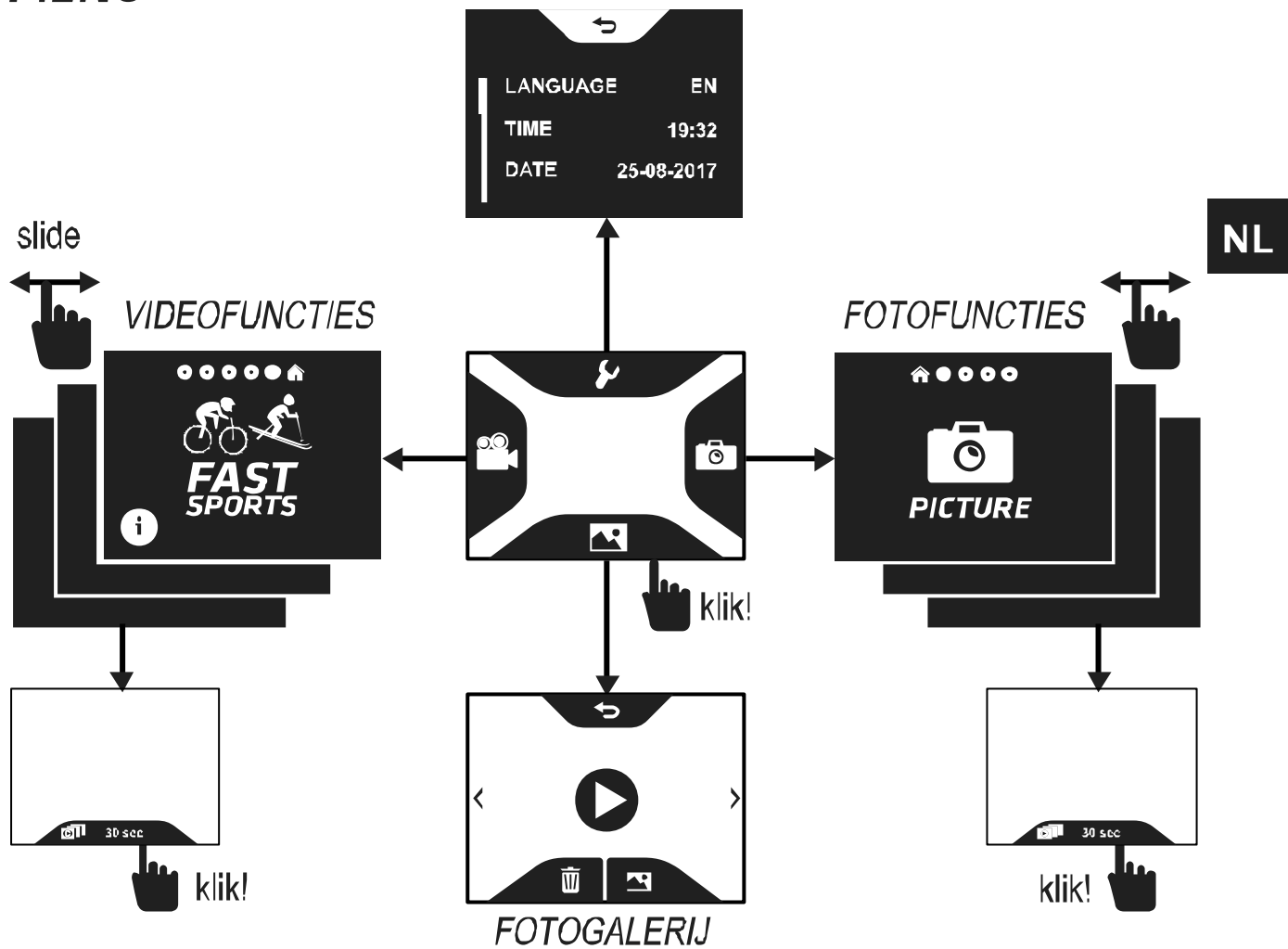

VIDEOFUNCTIES



Optimale instellingen voor dynamische sportbeoefening
1080p (Full HD)
60fps
groothoek en stabilisator



Optimale instellingen voor langzame sporttakken
1080p (Full HD)
30fps
groothoek

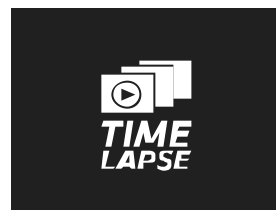

Timelapse video
1 foto / 2s, 5s, 10s, 30s, 60s, 300s



Slow motion video
720p / 120fps

 CUSTOM	RESOLU- TIE	NTSC (fps)	PAL (fps)	Gezichtsveld
	4K 2.7K 2.7K (4:3) 1440P 1080P 960P 720P	15 24/30 30 24/30 24/30/60 60 30/60/120	12.5 24/25 25 24/25 24/25/50 50 25/50/120	W : Breed W/M : Breed/Medium W : Breed W : Breed W/M/N : Breed/Medium/Smal W : Breed W/M/N : Breed/Medium/Smal

FOTOFUNCTIES

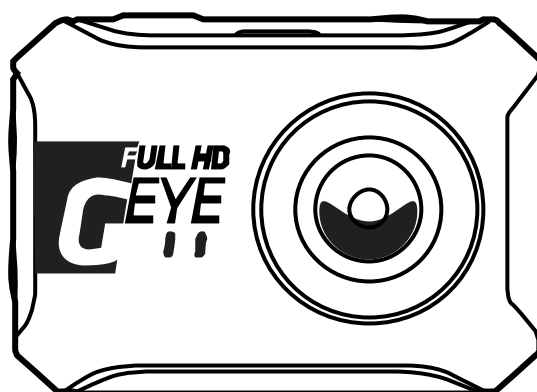

Klassieke foto
 16 MP, 12 MP, 8
 MP, 5 MP

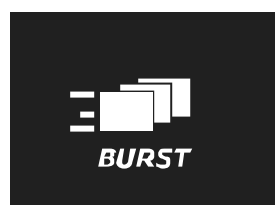

Snelle fotoserie
 x30 pics / 1s, 2s,
 3s, 6s
 x10 pics / 1s, 2s, 3s
 x5 pics/s
 x3 pics/s

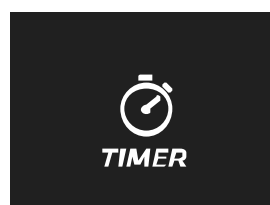

Zelfontspanner
 1s, 3s, 5s, 10s, 30s

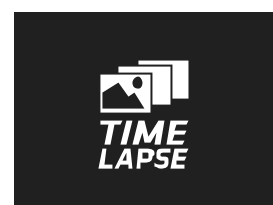

Timelapse foto
 1 foto / 2s, 5s, 10s,
 30s, 60s, 300s

ALGEMENE INSTELLINGEN (1/3)

GELUID

On
Off

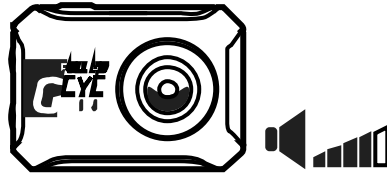

LED'S

On
Off

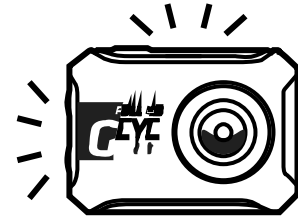

NL

ROTAREN

OMHOOG
ONDER
AUTOMATISCH

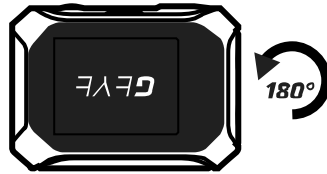

LCD STANDBY

On
Off

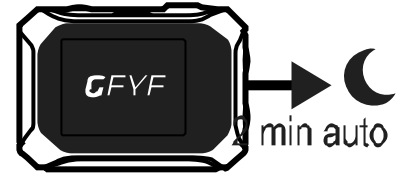

AUTO On/Off

On
Off

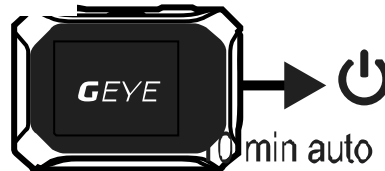

BEKIJKEN

On
Off

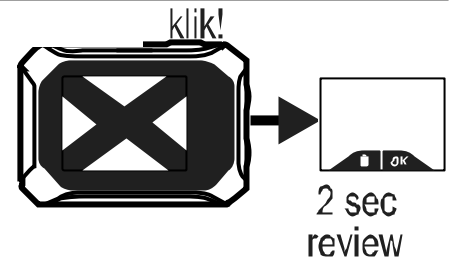

ALGEMENE INSTELLINGEN (2/3)

LAATSTE MODUS

On
Off

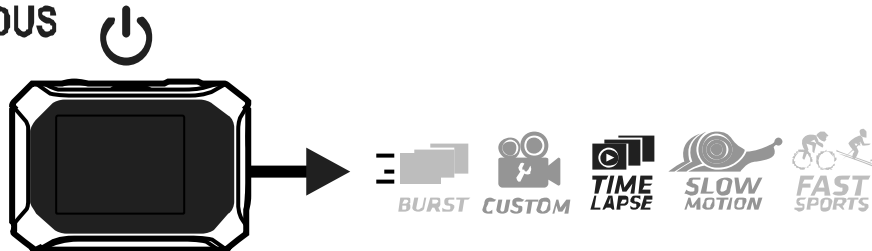

Activeert de camera in de laatste video/fotofunctie

FAST REC:

On
Off



Activeert de camera en start de video/
foto-opname

PAUZE

On
Off



Activeert de functie Opname pauzeren

ALGEMENE INSTELLINGEN (3/3)

VERVORMING:

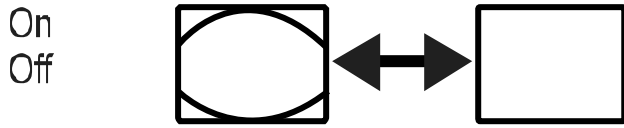

VIDEOLUS

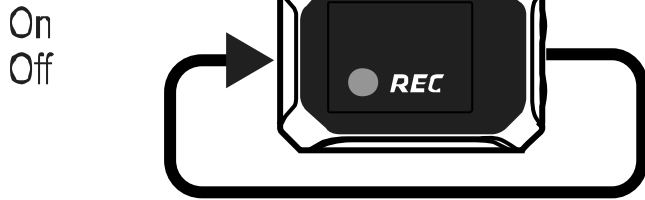

UITGANG

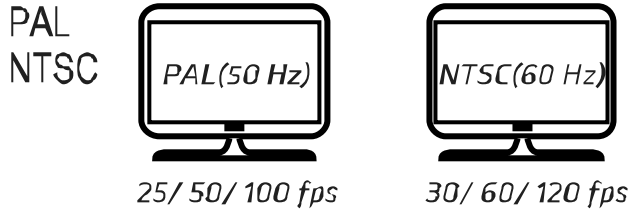

BEGINWAARDEN

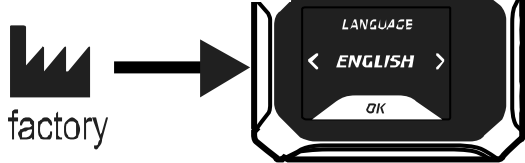

SD-FORMAAT

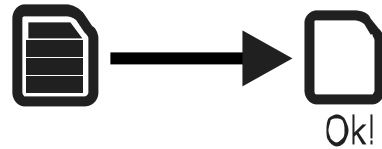

WEERGEVEN / BEDIENEN

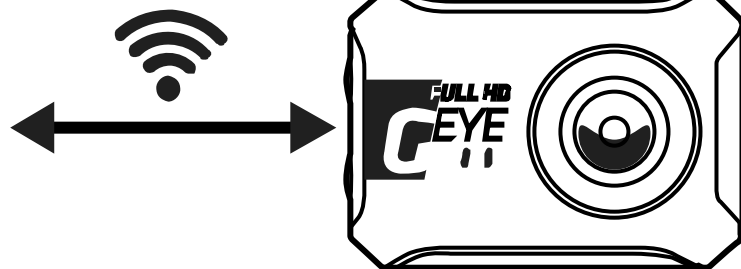

Uw camera weergeven, instellen en bedienen via het wifisignaal van uw smartphone.

Activeer de wifi van uw smartphone en volg de instructies van de applicatie.

AFSTANDBEDIENING (OPTIONEEL)

Uw afstandsbediening koppelen door te procedure te volgen nadat u de functie AFSTANDBEDIENING hebt geactiveerd in de algemene camera-instellingen.

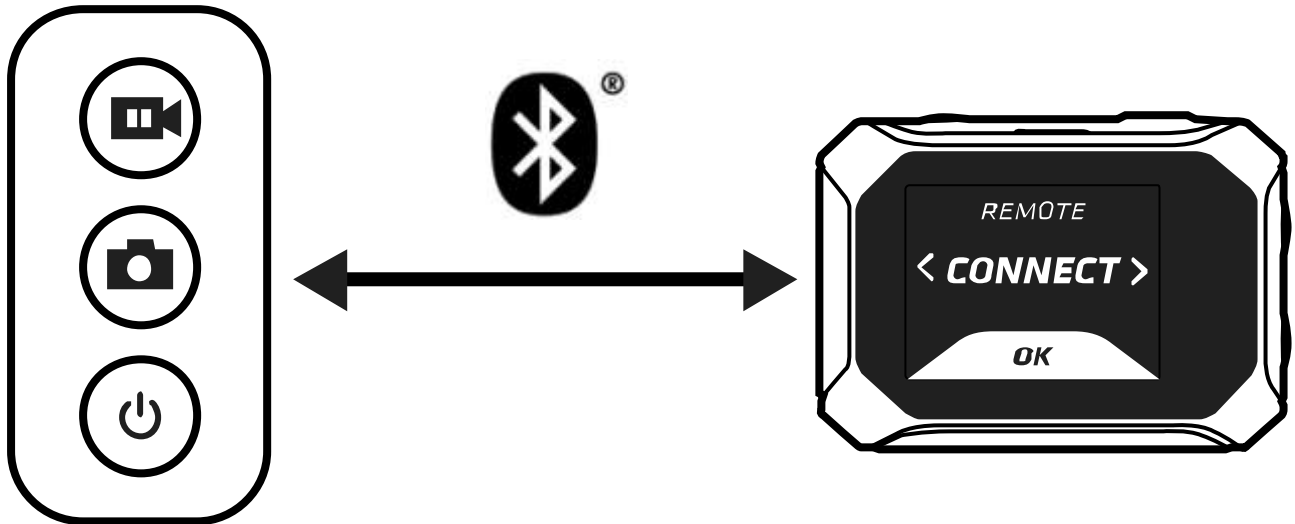

TV WEERGAVE

Met behulp van een mini-HDMI kabel (optioneel) kunt u het video/fotomateriaal weergeven op een HD televisie.

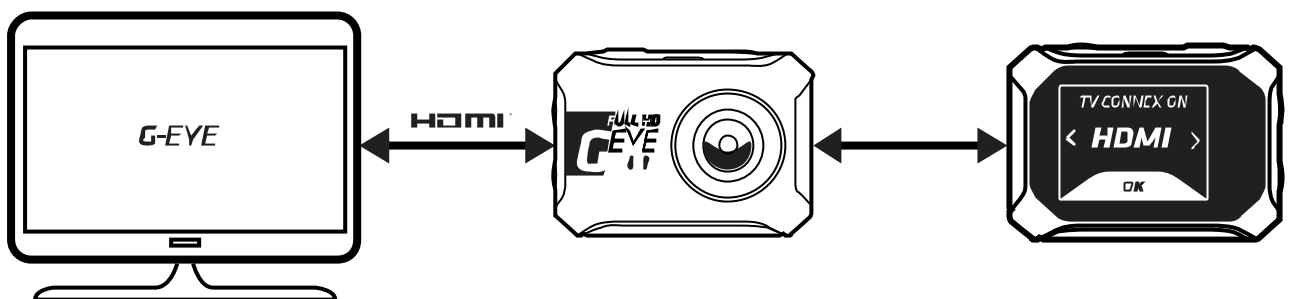

DE CAMERA BEVESTIGEN

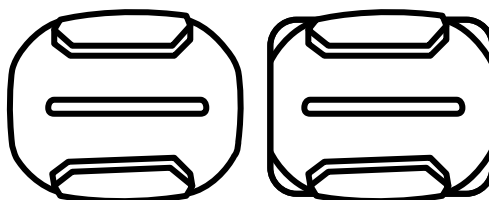

De zelfklevende houders uitsluitend op een schone gladde ondergrond bevestigen bij kamertemperatuur.

Wacht 24 uur voordat u de camera gebruikt.

TECHNISCHE SPECIFICATIES

Gewicht & afmetingen GEYE900:
Gewicht: 106g / 207g met behuizing
Hoogte: 50mm
Breedte: 68mm
Diepte: 27mm / 36mm met lens

Batterij type GEYE900:
Li-ion batterij, 1480mAh
Hoofdmateriaal: ABS

ALGEMENE PRODUCTVEILIGHEID



Het apparaat met zorg behandelen, niet laten vallen of blootstellen aan hevige schokken.

Let op, dit product is niet waterdicht zonder de waterdichte behuizing. Het product niet blootstellen aan water of in water dompelen.

Voor optimale veiligheid de knoppen niet aanraken wanneer het apparaat in bedrijf is. Verlies van concentratie kan gevaarlijk zijn.

Dit product niet uitbouwen, aangezien dit kan leiden tot schade en de garantie ongeldig maken.

Het gebruik van het apparaat bij koud weer (bij een temperatuur beneden -10°C) kan leiden tot een verminderde batterijcapaciteit en zo de levensduur van de batterij van het product verkorten.

BEPERKTE AANSPRAKELIJKHEID

DECATHLON is niet verantwoordelijk voor ongevallen of verwondingen die voortkomen uit het hanteren of het gebruiken van dit product tijdens deelname aan takken van sport met grote risico's. DECATHLON wil de gebruiker met name wijzen op risico's door het verlies van concentratie als gevolg van het hanteren van het product in gevaarlijke omstandigheden.

De gebruiker wordt gewaarschuwd dat hij/zij zelf de volledige juridische verantwoordelijkheid draagt voor het maken, delen en publiceren van de beelden die door dit product worden opgenomen.

EG-VERKLARING VAN CONFORMITEIT

DECATHLON verklaart hierbij dat het G-EYE 900 apparaat in overeenstemming is met de essentiële eisen en andere relevante bepalingen van de richtlijn 2014/53/EG.

De EG-conformiteitsverklaring is beschikbaar op de volgende link:

www.geonaute.com/en/ec-declaration-conformity

RECYCLERING

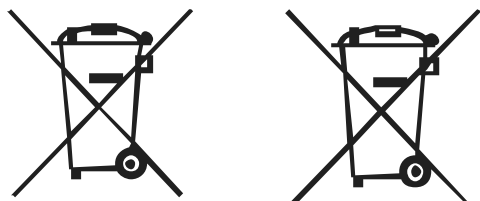

CONTACT OPNEMEN

Neem contact op met ons op
www.customercare.geonaute.com

NL

DESCRIÇÃO



pressão breve:
Iniciar vídeo / Colocar vídeo em pausa

pressão breve:
Tirar uma fotografia / Tirar uma fotografia no vídeo

pressão longa:
Ligar a câmara e iniciar a gravação / Parar a gravação

pressão longa:
Ligar a câmara e tirar uma fotografia



pressão longa:
On/Off



pressão longa:
WIFI On/Off

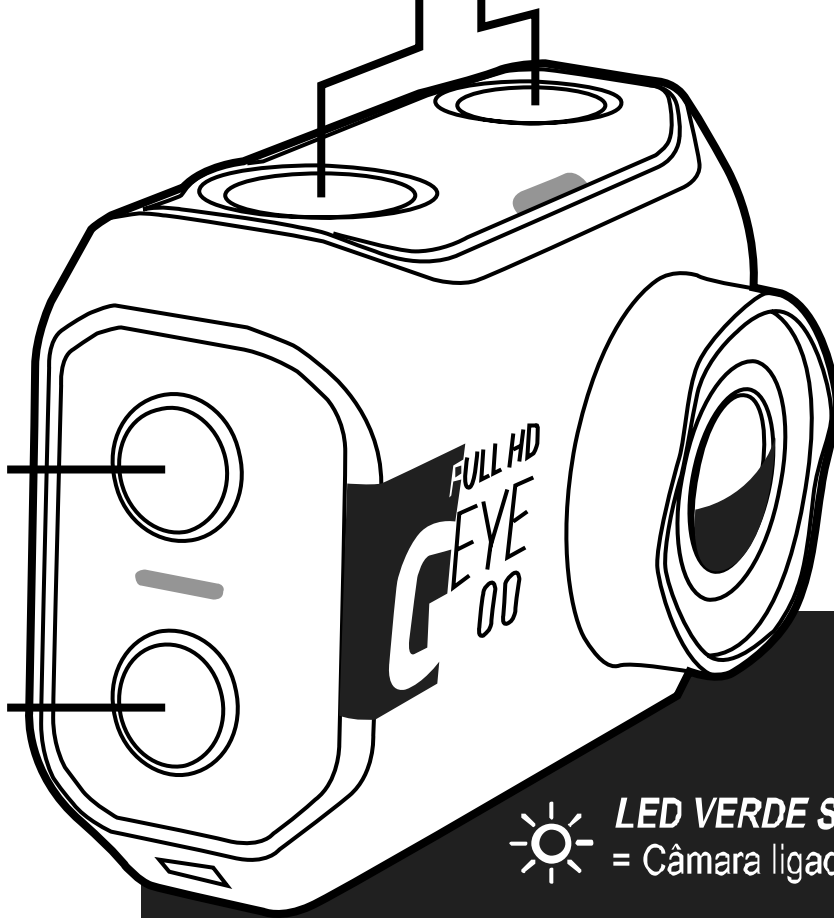

 **LED VERDE SÓLIDO**
= Câmera ligada

 **LED VERMELHO SÓLIDO**
= Vídeo em pausa ou câmara em carregamento.

LED VERMELHO INTERMITENTE
= Fotografia ou gravação de vídeo em curso ou bateria fraca.

PRIMEIROS PASSOS

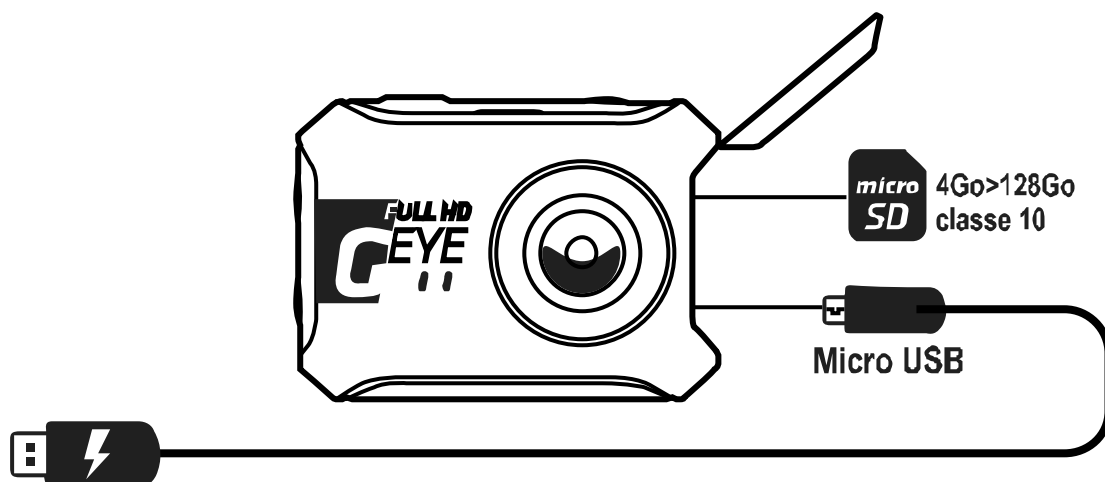

PT

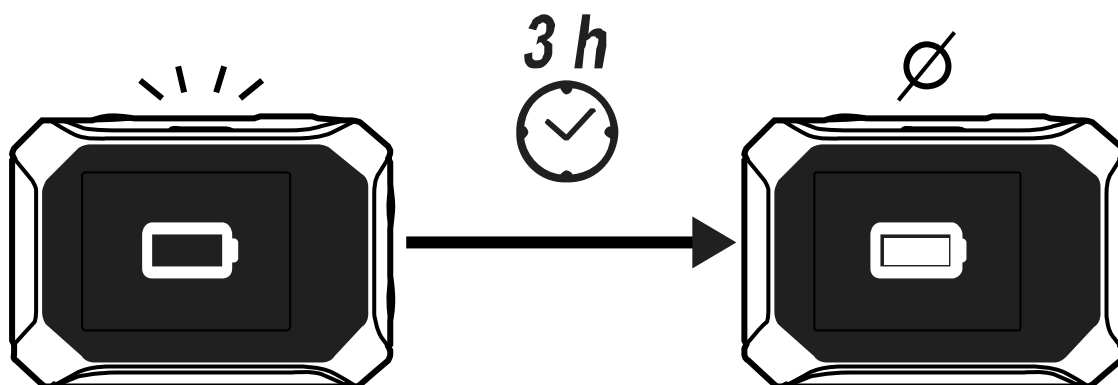

UTILIZAR COM A CAIXA DE PROTEÇÃO À PROVA DE ÁGUA

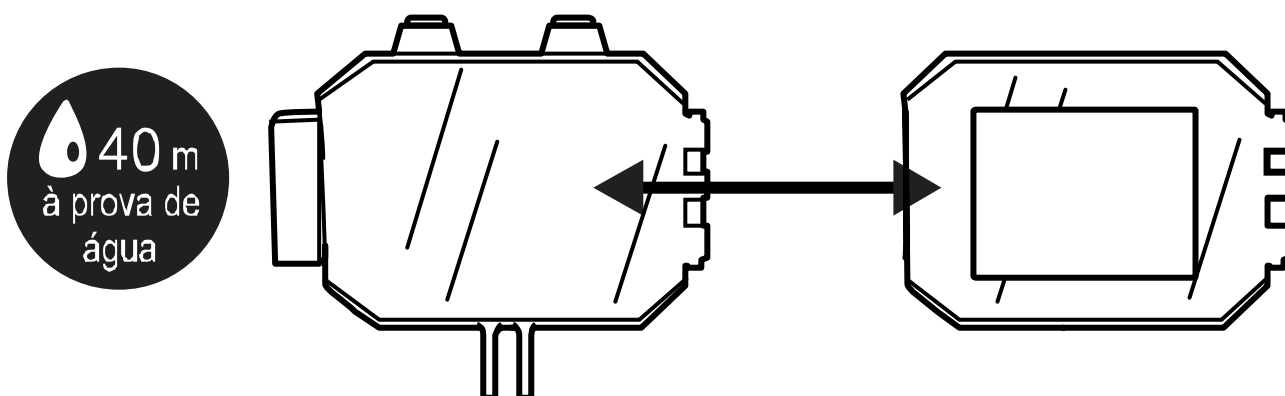

- Porta posterior padrão (cheio): impermeável a 40 m
Para garantir um isolamento perfeito, é importante manter a junta de vedação limpa. Lavar com água limpa.
- Porta posterior perfurada: para ambientes secos e isentos de poeiras:

acesso ao ecrã tátil e gravação de som mais eficiente.

MUDAR A PORTA POSTERIOR:

Abra a caixa totalmente, puxe a parte lateral da porta até esta desencaixar. Alinhe a nova porta com a dobradiça e feche a porta até obter um encaixe justo.



Utilize um respirador anti-embaciamento (acessório vendido em separado na DECATHLON)

MENU

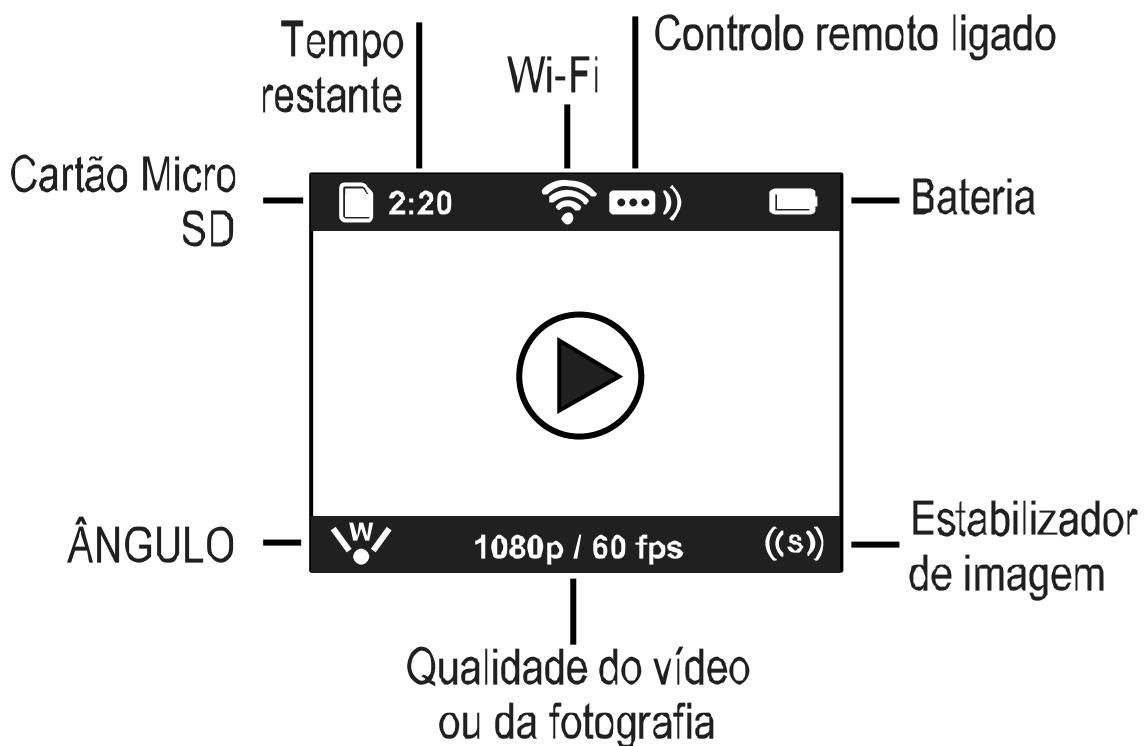

MENU

DEFINIÇÕES GERAIS

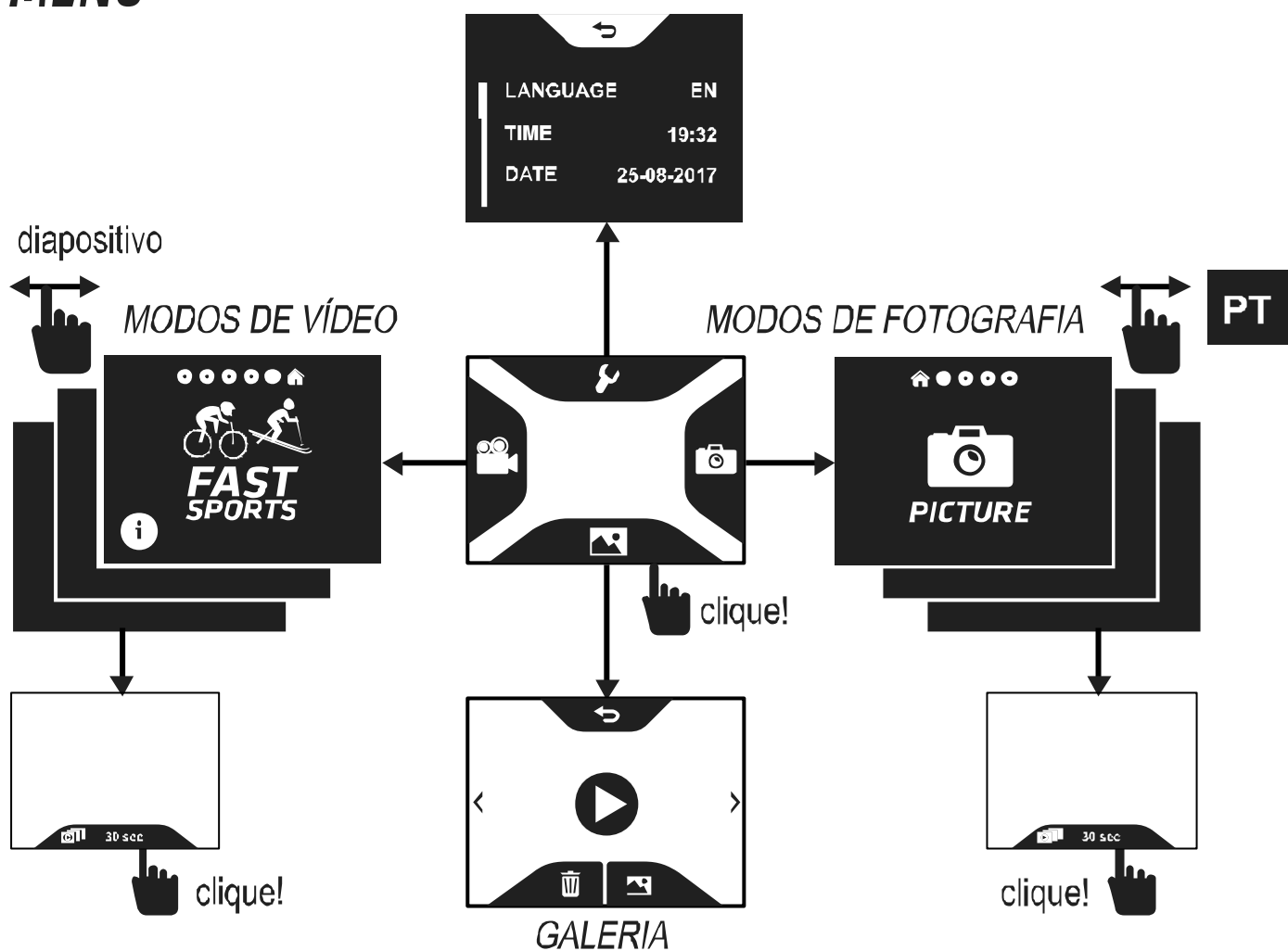

MODOS DE VÍDEO



Definições otimizadas para desportos dinâmicos
1080p (Full HD)
60 fps
grande angular e estabilizador



Definições otimizadas para desportos lentos
1080p (Full HD)
30 fps
grande angular

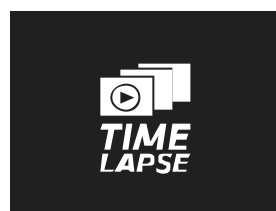

Vídeo de lapso de tempo
1 foto / 2 s, 5 s, 10 s, 30 s, 60 s, 300 s



Vídeo em câmara lenta
720p / 120 fps

 CUSTOM	RESOLUÇÃO	NTSC (fps)	PAL (fps)	Campo de visão
	4K 2.7K 2.7K (4:3) 1440P 1080P 960P 720P	15 24/30 30 24/30 24/30/60 60 30/60/120	12.5 24/25 25 24/25 24/25/50 50 25/50/120	W : Panorâmico W/M : Panorâmico/Médio W : Panorâmico W : Panorâmico W/M/N : Panorâmico/Médio/Estreito W : Panorâmico W/M/N : Panorâmico/Médio/Estreito

MODOS DE FOTOGRAFIA

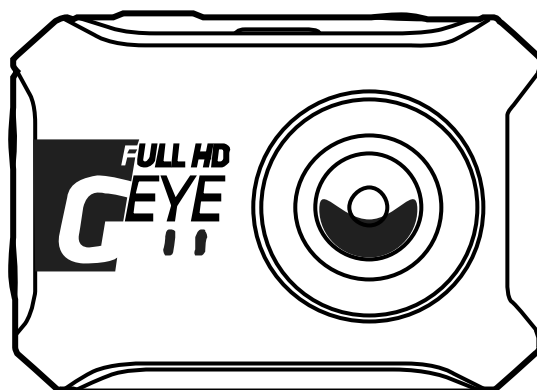

Fotografia clássica
 16 MP, 12 MP, 8 MP, 5 MP

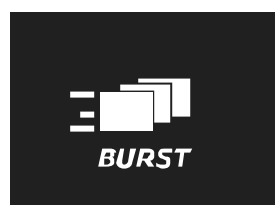

Modo de rajada
 x30 fotos / 1 s, 2 s, 3 s, 6 s
 x10 fotos / 1 s, 2 s, 3 s
 x5 fotos/s
 x3 fotos/s

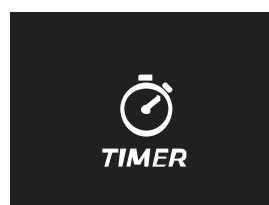

Temporizador
 1 s, 3 s, 5 s, 10 s, 30 s

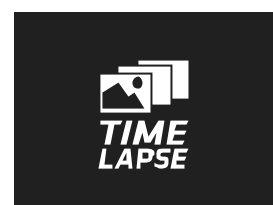

Fotografia de lapso de tempo
 1 fotografia / 2 s, 5 s, 10 s, 30 s, 60 s, 300 s

DEFINIÇÕES GERAIS (1/3)

SOM
On
Off



LEDS
On
Off

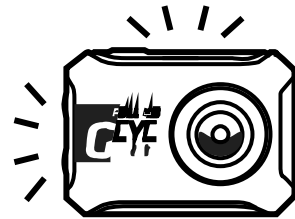

RODAR
CIMA
BAIXO
AUTO

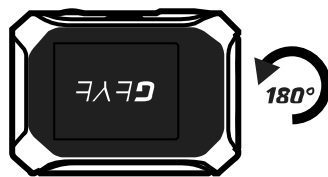

**LCD
STANDBY**
On
Off

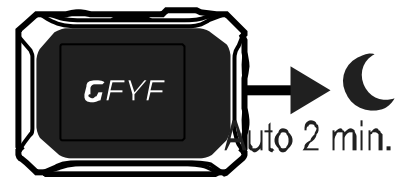

AUTO On/Off
On
Off



VISUALIZAÇÃO
On
Off

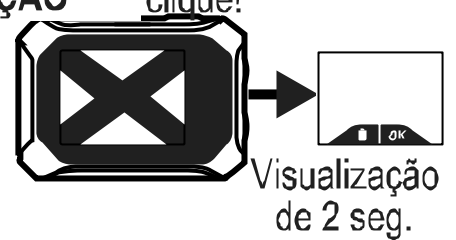

DEFINIÇÕES GERAIS (2/3)

ÚLTIMO MODO
On
Off

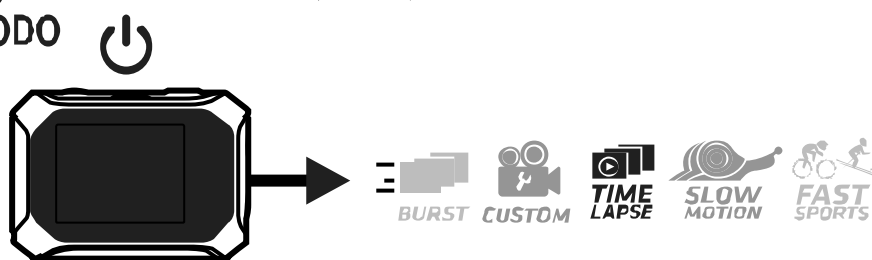

Ativar a câmara no último modo de vídeo/fotografia

FAST REC:
On
Off

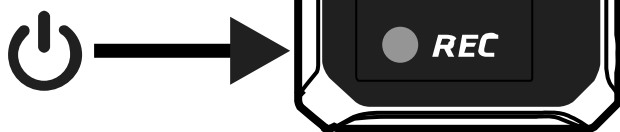

Ativar a câmara e iniciar o vídeo/
fotografia de imediato

PAUSA
On
Off

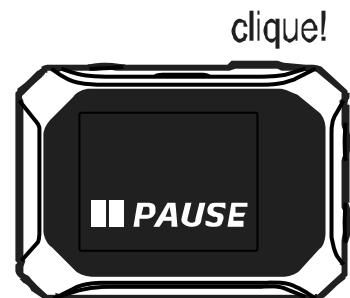

Ativar a função de pausa da gravação

DEFINIÇÕES GERAIS (3/3)

Distorção:

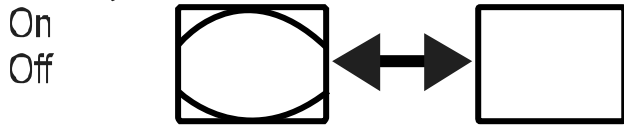

LOOP VIDEO

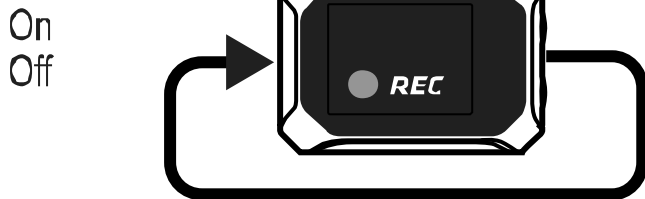

SAÍDA

PAL
NTSC



25/ 50/ 100 fps

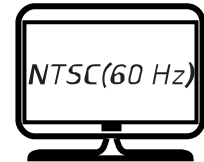

30/ 60/ 120 fps

REINICIAR TUDO

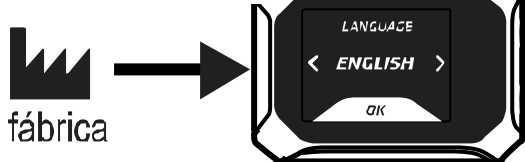

FORMATAR SD

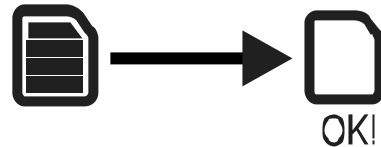

VISUALIZAÇÃO / CONTROLO

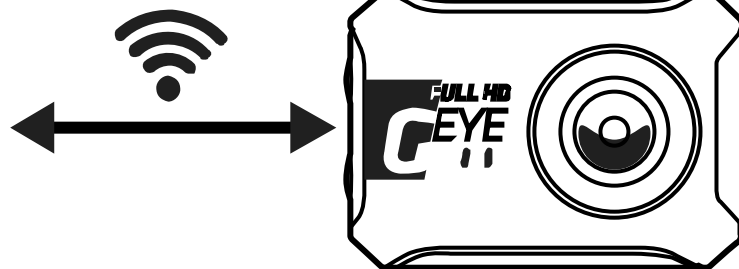

Veja, configure e controle a sua câmara através da rede Wi-Fi do seu smartphone.

Ative a funcionalidade Wi-Fi da câmara e do seu smartphone e siga as instruções da aplicação.

CONTROLO REMOTO (OPCIONAL)

Sincronize o seu controlo remoto seguindo o procedimento após ativar a função TELECOMANDO nas definições gerais da câmara.

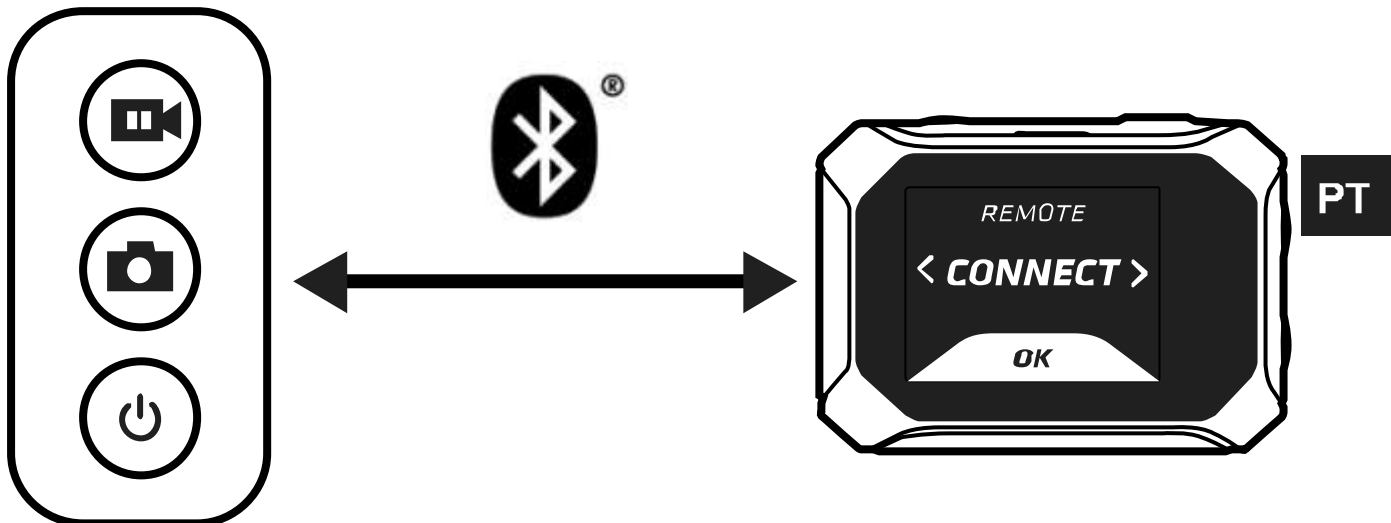

VISUALIZAÇÃO EM TV

Utilizando um cabo mini-HDMI (opcional), pode transmitir o seu conteúdo de fotografias/vídeo para um televisor HD.

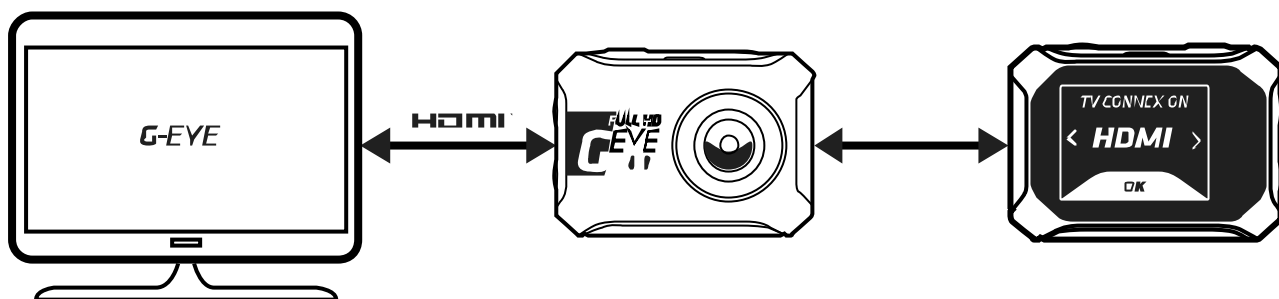

FIXAÇÃO DA CÂMARA

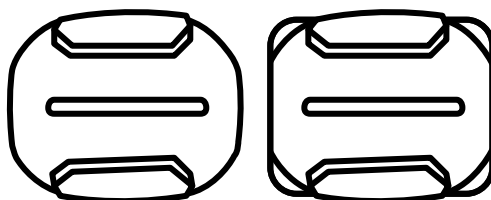

Fixe os suportes adesivos apenas a superfícies limpas e suaves e à temperatura ambiente.

Aguarde 24 horas antes de utilizar.

ESPECIFICAÇÕES TÉCNICAS

GEYE900 - Peso e dimensões:

Peso: 106 g / 207 g com caixa

Altura: 50 mm

Largura: 68 mm

Profundidade: 27 mm / 36 mm com lente

GEYE900 - Tipo de bateria:

Bateria de íões de lítio, 1480 mAh

Material principal do corpo: ABS

SEGURANÇA GERAL DO PRODUTO

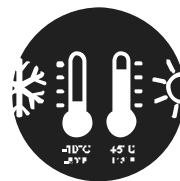

Manuseie este dispositivo com cuidado, evite deixá-lo cair e não o exponha a impactos grandes.

Cuidado, este produto não é à prova de água sem a caixa de proteção fornecida para esse efeito. Não o exponha à água e não o submerja.

Para maior segurança, não toque nos botões durante a utilização. Perder a concentração pode ser perigoso.

Não desmonte o produto, uma vez que fazê-lo poderia danificá-lo e invalidar a garantia. A utilização deste dispositivo em condições de frio extremo (temperaturas inferiores a -10 °C) pode causar uma diminuição da capacidade da bateria, assim reduzindo a autonomia do produto.

RESPONSABILIDADE LIMITADA

A DECATHLON não é responsável por acidentes ou lesões resultantes do manuseamento ou utilização deste produto durante a participação em desportos de alto risco. Especificamente, a DECATHLON pretende informar o utilizador acerca do risco possível de perda de concentração devido ao manuseio e à utilização do produto em condições perigosas.

O utilizador é desta forma alertado de que assume todas as responsabilidades legais pela captura, partilha e publicação de imagens captadas com este produto.

DECLARAÇÃO DE CONFORMIDADE CE

Pelo presente documento, a DECATHLON declara que o aparelho G-EYE 900 está em conformidade com os requisitos essenciais e outras disposições relevantes da Diretiva 2014/53/EU.

A declaração de conformidade CE está disponível para consulta na seguinte ligação:
www.geonaute.com/en/ec-declaration-conformity

RECICLAGEM

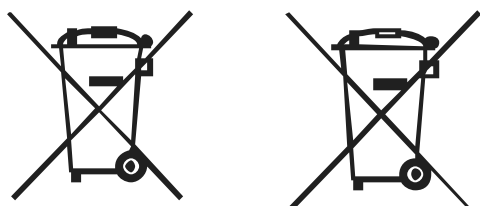

ENTRE EM CONTACTO CONNOSCO

Contacte-nos em
www.customercare.geonaute.com

PT

OPIS



krótkie naciśnięcie:
Włączenie/pauza wideo

długie naciśnięcie:
Włącza kamerę i uruchamia nagrywanie/
zatrzymuje nagrywanie



krótkie naciśnięcie:
Zapis zdjęcia / Zapis zdjęcia
podczas nagrywania wideo

długie naciśnięcie:
Włącza kamerę i rejestruje zdjęcie



długie naciśnięcie:
On/Off



długie naciśnięcie:
WIFI On/Off

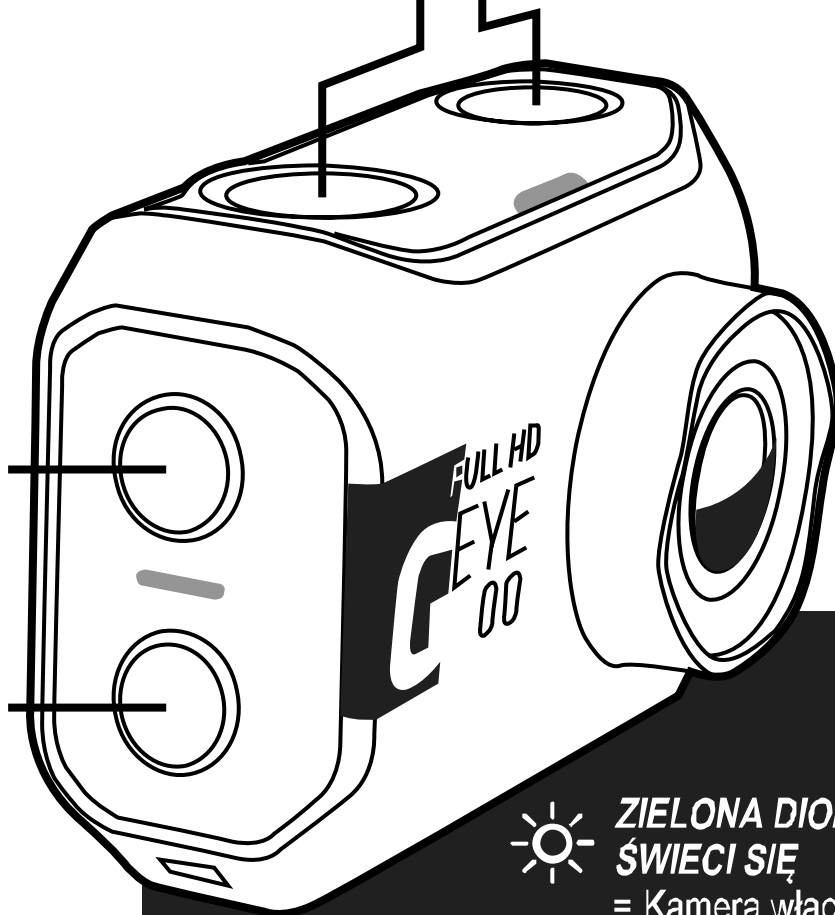

ZIELONA DIODA LED ŚWIECI SIĘ
= Kamera włączona



CZERWONA DIODA LED ŚWIECI SIĘ
= Wideo spauzowane lub kamera w trakcie ładowania.

CZERWONA DIODA LED MIGA

= Trwa rejestracja zdjęcia lub wideo lub rozładowana bateria.

PIERWSZE KROKI

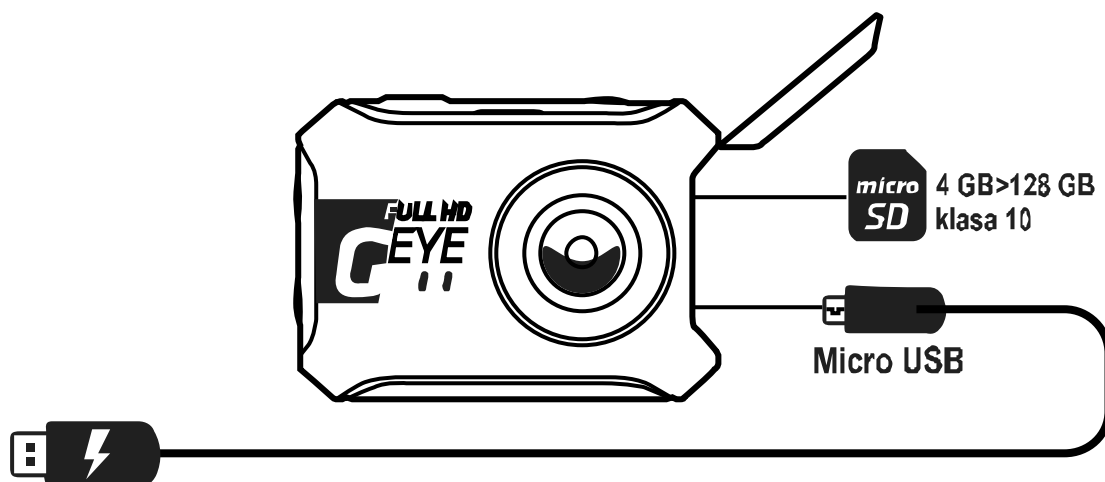

PL

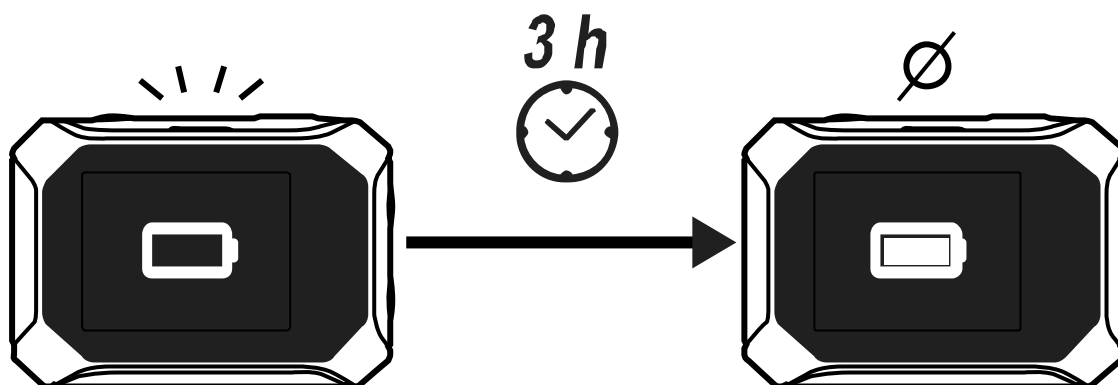

UŻYWANIE W SZCZELNEJ OBUDOWIE

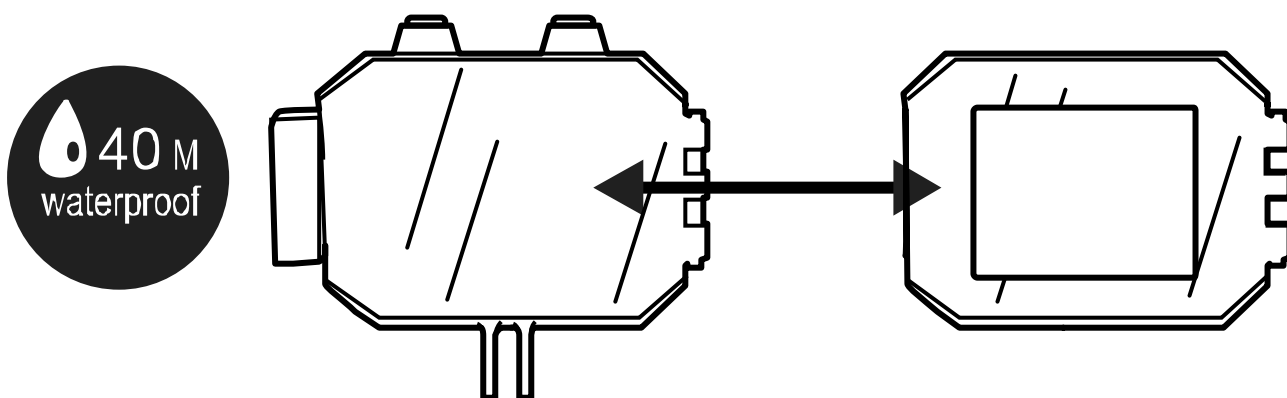

- Klapka tylna standardowa (pełna): szczelność do 40 m
Aby zapewnić idealną szczelność uszczelkę należy utrzymywać w czystości.
Splukać czystą wodą.
- Klapka tylna ażurowa: miejsca suche i bez pyłu;
dostęp do ekranu dotykowego i lepsza rejestracja dźwięku.

WYMIANA KLAPKI TYLNEJ:

Otworzyć całkowicie obudowę, pociągnąć za klapkę z boku do momentu jej odłączenia. Wyrównać nową klapkę z zawiasem i zamknąć klapkę do momentu prawidłowego zablokowania.



Używać produktów zapobiegających zaparowaniu (akcesoria sprzedawane oddzielnie w sklepach DECATHLON)

MENU

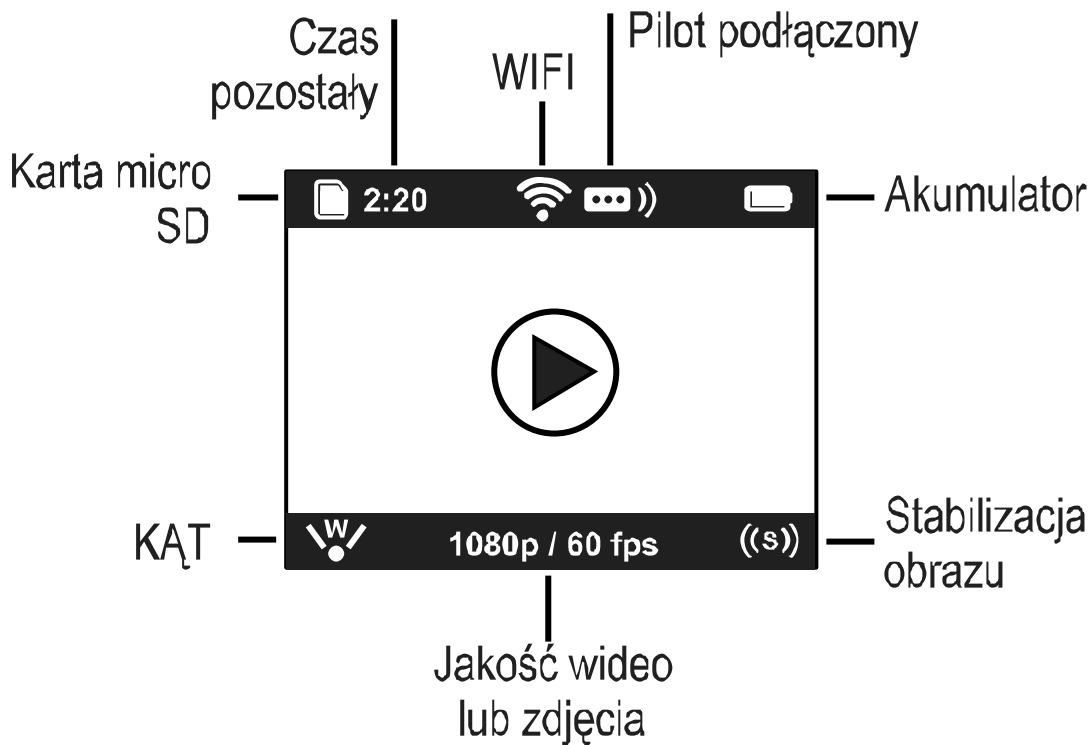

MENU

USTAWIENIA OGÓLNE

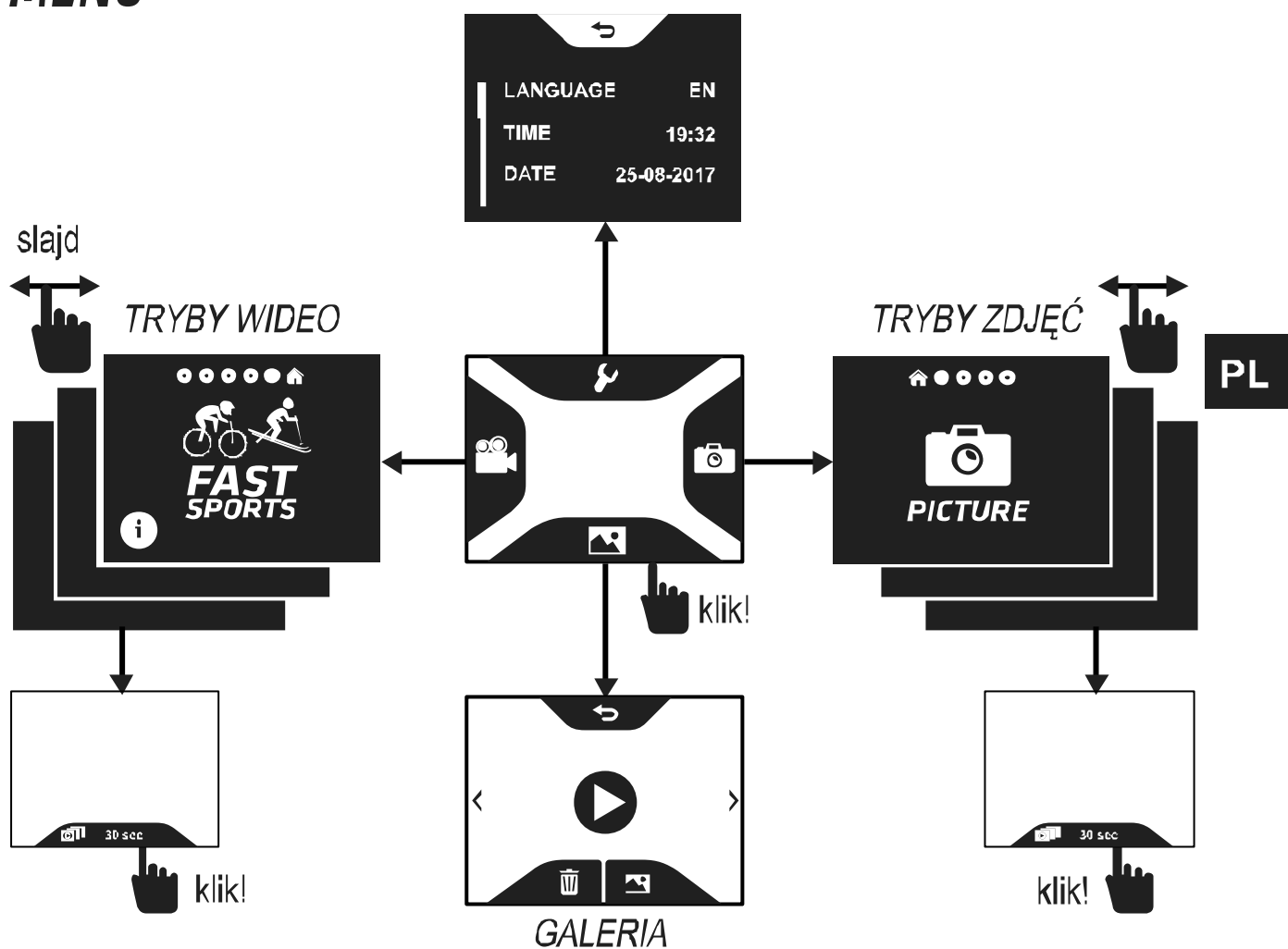

TRYBY WIDEO



Ustawienia zoptymalizowane dla dynamicznych sportów
1080p (Full HD)
60 kl./s
szeroki kąt i stabilizacja obrazu



Ustawienia zoptymalizowane dla sportów o mniejszej dynamice
1080p (Full HD)
30 kl./s
szeroki kąt

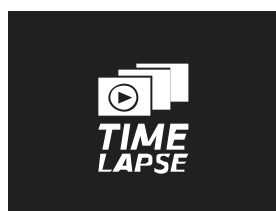

Wideo poklatkowe
1 zdjęcie / 2 s, 5 s, 10 s, 30 s, 60 s, 300 s



Film w zwolnionym tempie
720p / 120 kl./s

 CUSTOM	Rozdzielczość	NTSC (fps)	PAL (fps)	Pole widzenia
	4K 2.7K 2.7K (4:3) 1440P 1080P 960P 720P	15 24/30 30 24/30 24/30/60 60 30/60/120	12.5 24/25 25 24/25 24/25/50 50 25/50/120	W : Szeroki ką W/M : Szeroki/średni ką W : Szeroki ką W : Szeroki ką W/M/N : Szeroki/Średni/Wąski ką W : Szeroki ką W/M/N : Szeroki/Średni/Wąski ką

TRYBY ZDJĘĆ

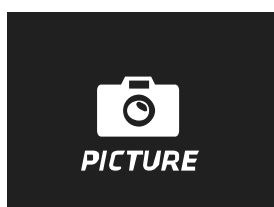
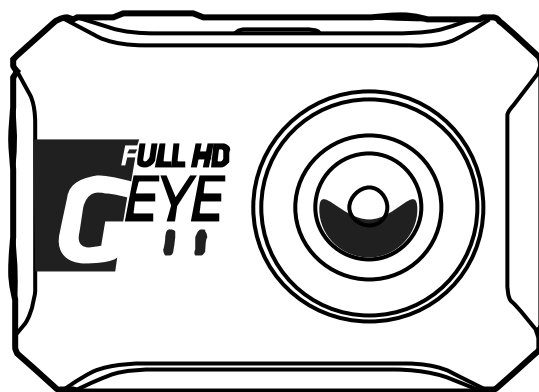

Zdjęcia klasyczne
 16 MP, 12 MP, 8
 MP, 5 MP

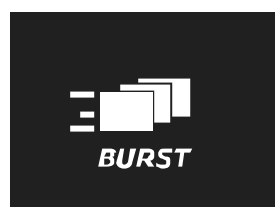

Serie zdjęć
 x30 zdjęć / 1s, 2s,
 3s, 6s
 x10 zdjęć / 1s,
 2s, 3s
 x5 zdjęć/s
 x3 zdjęć/s

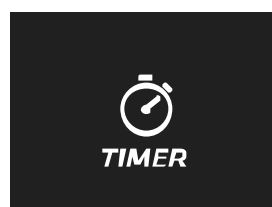

Samowyzwalacz
 1s, 3s, 5s, 10s, 30s



Zdjęcia poklatkowe
 1 zdjęcie / 2 s, 5
 s, 10 s, 30 s, 60 s,
 300 s

USTAWIENIA OGÓLNE (1/3)

DŹWIĘK
On
Off

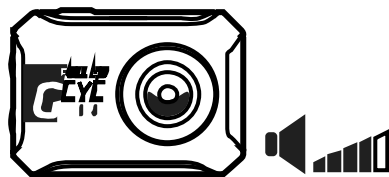

DIODY
On
Off

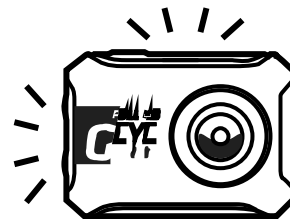

OBRÓĆ
W GÓRĘ
W DÓŁ
AUTO



**LCD
STANDBY**
On
Off

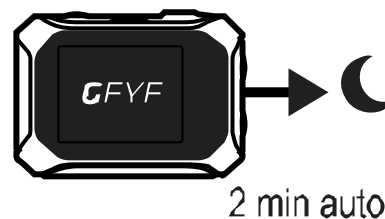

PL

AUTO On/Off
On
Off

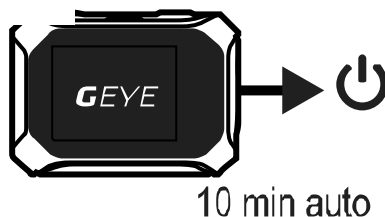

PODGLĄD
On
Off

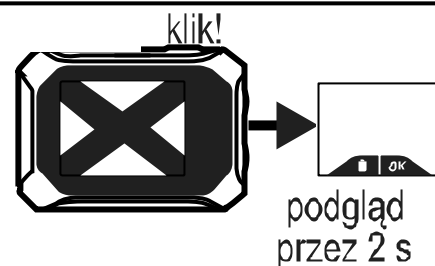

USTAWIENIA OGÓLNE (2/3)

OSTATNI TRYB 
On
Off

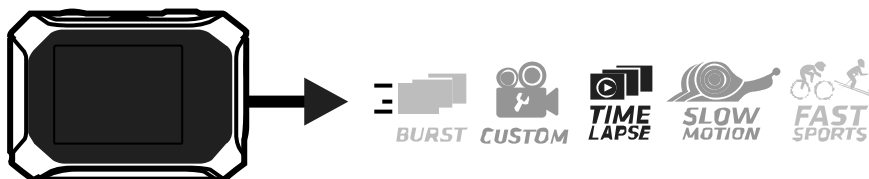

Włącza kamerę w ostatnim trybie video/zdjęć

FAST REC:
On
Off

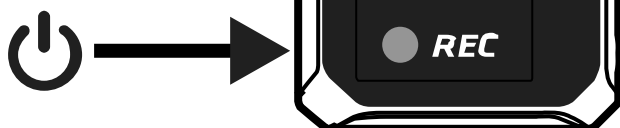

Włącza kamerę i uruchamia nagrywanie
video/zdjęcia

PAUZA
On
Off



Włącza funkcję pauzy nagrywania

USTAWIENIA OGÓLNE (3/3)

ZNIEKSZTAŁCENIE :

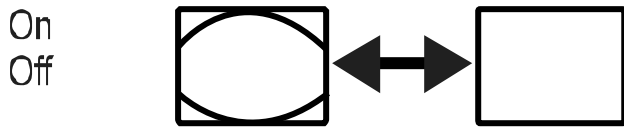

WIDEO W PĘTLI

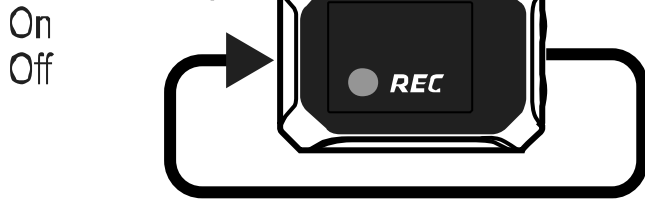

WYJŚCIE

PAL
NTSC



25/ 50/ 100 fps

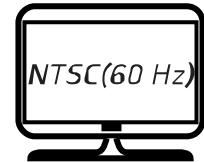

30/ 60/ 120 fps

RESETUJ WSZYSTKO

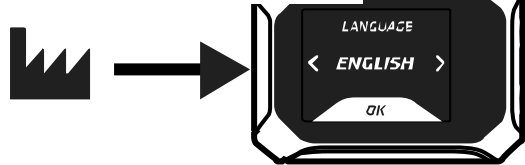

ustawienia fabryczne

FORMAT SD

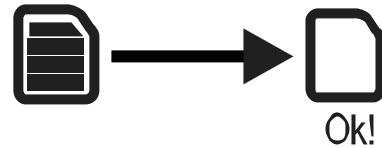

WYŚWIETLANIE / STEROWANIE

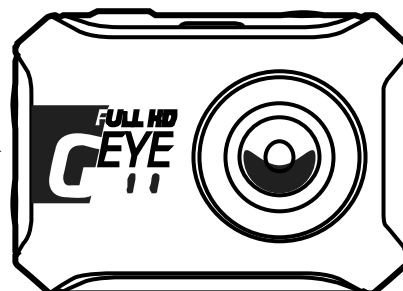

PL

Wyświetlanie, zmiana ustawień i sterowanie kamerą za pomocą wifi smartfona.

Włącz wifi w kamerze i smartfonie, a następnie postępuj zgodnie z instrukcjami w aplikacji.

PILOT (OPCJA)

Sparuj pilota zgodnie z poniższą procedurą po włączeniu funkcji REMOTE w ustawieniach ogólnych kamery.

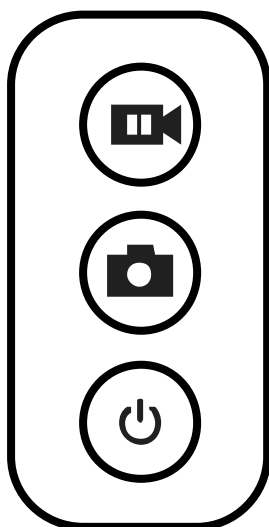

WYŚWIETLANIE NA TELEWIZORZE

Za pomocą kabla mini-HDMI (dostępny w opcji) można wyświetlać materiały wideo i zdjęcia na telewizorze HD.

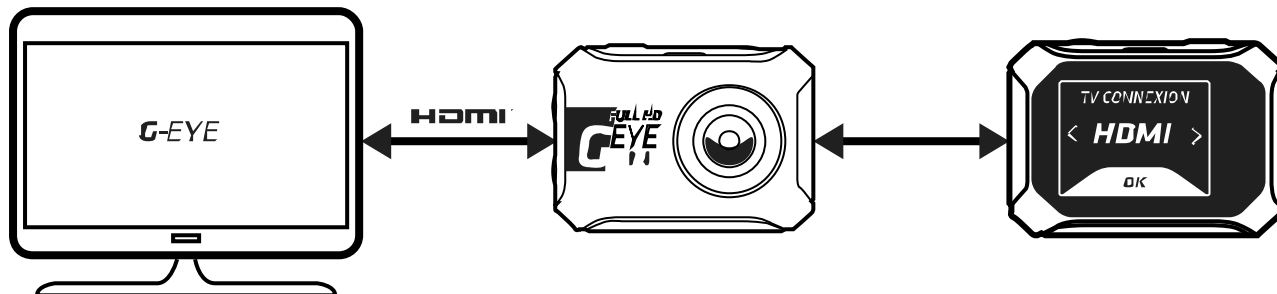

MONTAŻ KAMERY

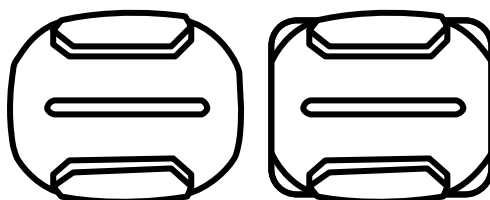

Mocować podkładki samoprzylepne na czystej i gładkiej powierzchni tylko w temperaturze pokojowej.
Zaczekać 24 h przed użyciem.

DANE TECHNICZNE

Masa i wymiary GEYE900:

Masa: 106 g / 207 g w obudowie

Wysokość: 50 mm

Szerokość: 68 mm

Głębokość: 27 mm / 36 mm z obiektywem

Akumulator GEYE900:

Akumulator litowo-jonowy, 1480 mAh

Główny materiał: ABS

OGÓLNE INFORMACJE NA TEMAT BEZPIECZEŃSTWA



Urządzeniem należy posługiwać się z zachowaniem ostrożności, nie upuszczać go i

nie narażać na silne uderzenia

Ostrzeżenie, ten produkt nie jest wodoodporny bez obudowy wodoodpornej. Nie narażać na działanie wody i nie zanurzać

Aby zwiększyć bezpieczeństwo, nie należy naciskać przycisków w czasie używania. Utrata koncentracji może być niebezpieczna

Nie demontować produktu z względu na ryzyko uszkodzenia i utraty gwarancji

Używanie urządzenia w bardzo niskich temperaturach (mniejszych niż -10°C) może spowodować obniżenie pojemności akumulatora i zmniejszyć jego trwałość

OGRANICZENIE ODPOWIEDZIALNOŚCI

PL

DECATHLON nie ponosi odpowiedzialności za wypadki lub szkody spowodowane obsługą lub użytkowaniem tego produktu w czasie uprawiania sportów ekstremalnych. DECATHLON pragnie poinformować użytkownika na temat możliwych zagrożeń związanych z utratą koncentracji związaną z noszeniem urządzenia w niebezpiecznych sytuacjach.

Użytkownika poinformowano o tym, że ponosi całkowitą prawną odpowiedzialność za nagrywanie, udostępnianie i publikowanie obrazów zarejestrowanych za pomocą produktu.

DEKLARACJA ZGODNOŚCI WE

DECATHLON oświadcza, że urządzenie G-EYE 900 jest zgodne z podstawowymi wymaganiami i innymi przepisami dyrektywy 2014/53/EU.

Deklaracja zgodności WE jest dostępna pod następującym adresem:

www.geonaute.com/en/ec-declaration-conformity

RECYKLING

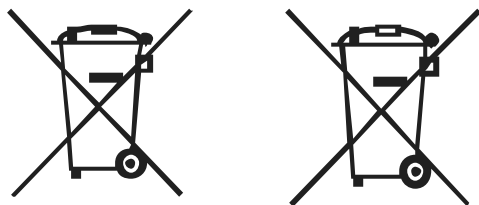

KONTAKT

Skontaktuj się z nami pod adresem
www.customercare.geonaute.com

LEÍRÁS



Röviden nyomja le :
Videó indítása/szünet

Hosszan nyomja le :
Kapcsolja be a kamerát és indítsa el a felvételt/állítsa le a felvételt



röviden nyomja le :
Készítsen felvételt/Készítsen felvételt videó felvétele közben

Hosszan nyomja le :
Kapcsolja be a kamerát és készítsen egy képet



Hosszan nyomja le :
On/Off



Hosszan nyomja le :
WIFI On/Off

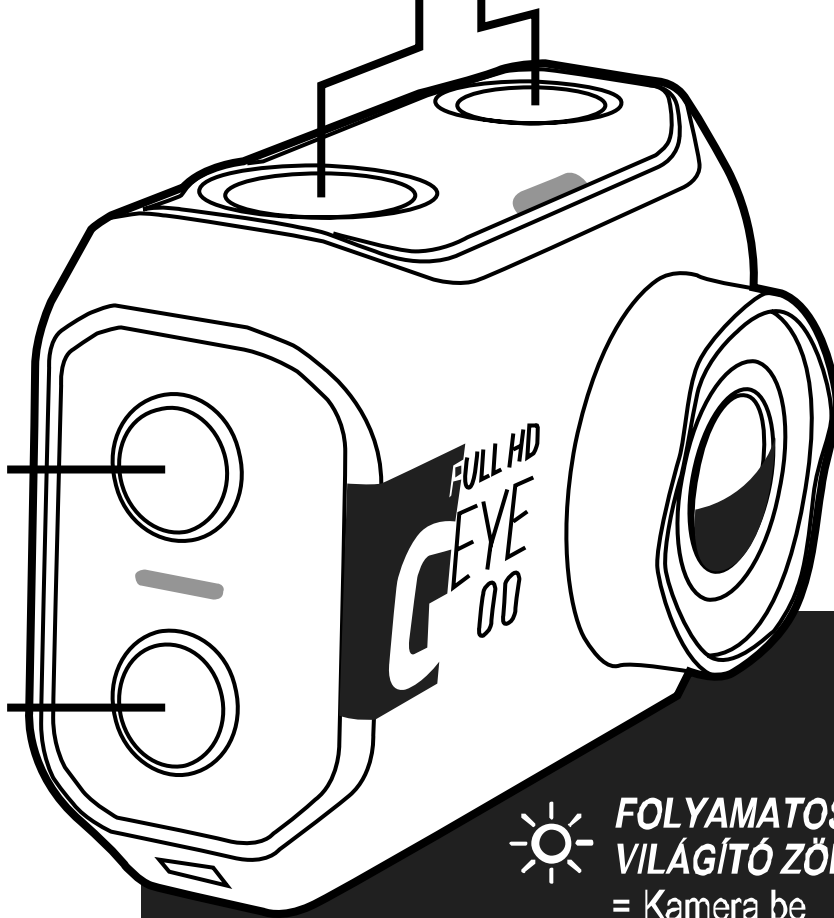

FOLYAMATOSAN VILÁGÍTÓ ZÖLD LED
= Kamera be



FOLYAMATOSAN VILÁGÍTÓ VÖRÖS LED
= Vidéo en pause ou caméra en charge.

VILLOGÓ VÖRÖS LED

= Fotó vagy videó készítése folyamatban vagy alacsony akkumulátor töltöttség.

ELSŐ LÉPÉSEK

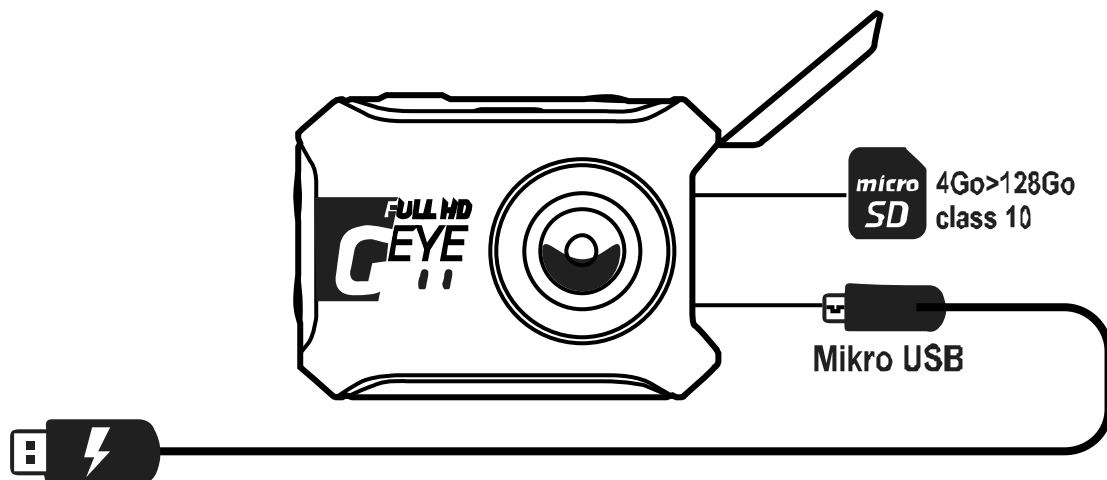

HU

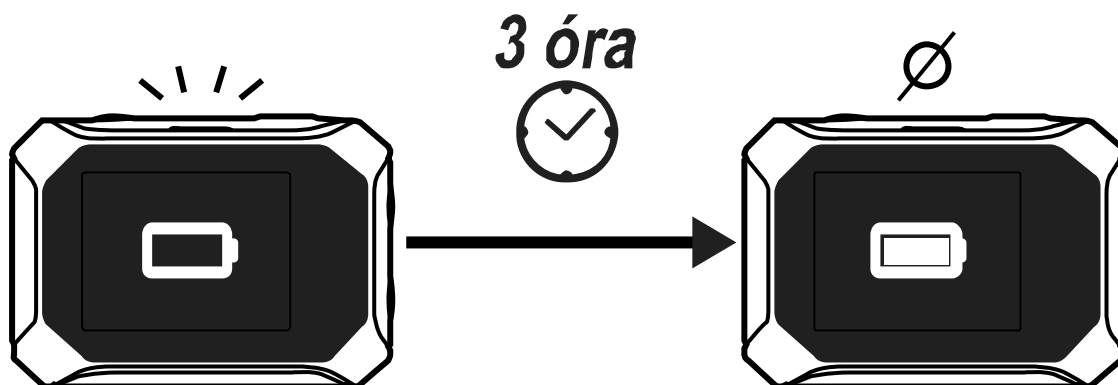

VÍZÁLLÓ TOKKAL HASZNÁLJA

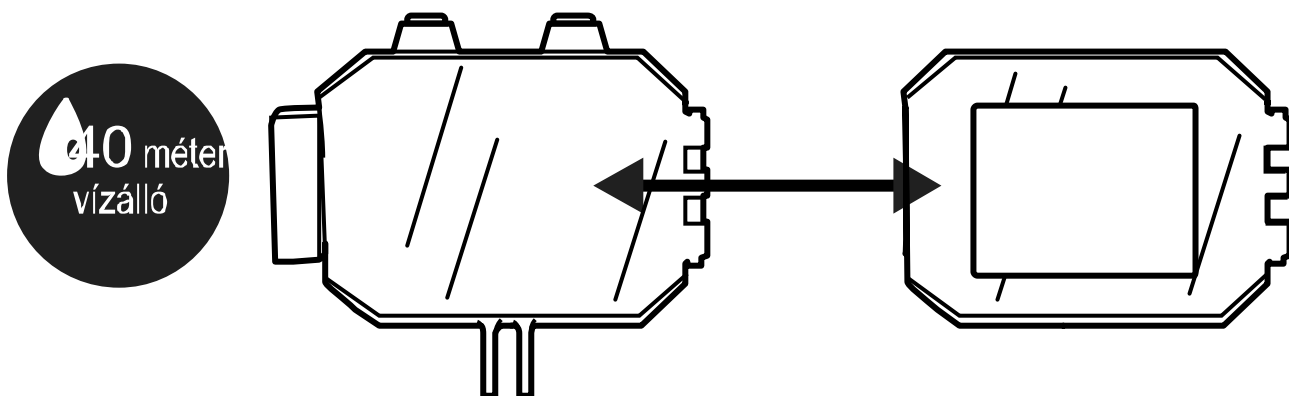

- Standard hátsó ajtó (teljes) : 40 méterig vízálló
A tökéletes tömítés érdekében fontos tisztán tartani a szigetelést.
Rincer à l'eau claire.
- Perforált hátsó ajtó : tiszta és pormentes környezetre :
az érintőképernyő elérése és hatékonyabb hangfelvétel.

A HÁTSÓ AJTÓ CSERÉJE :

Teljesen nyissa ki a tokot, nyomja meg az ajtó oldalát, amíg szétjön.

Igazítsuk az ajtót egy vonalba a zsanérral és zárjuk be az ajtót, amíg nem záródik tökéletesen.

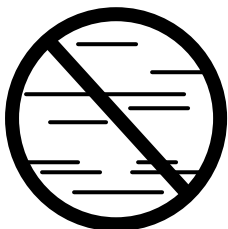

Használja a ködgátló betétet (a DECATHLON-nál külön kiegészítőként kapható)

MENÜ

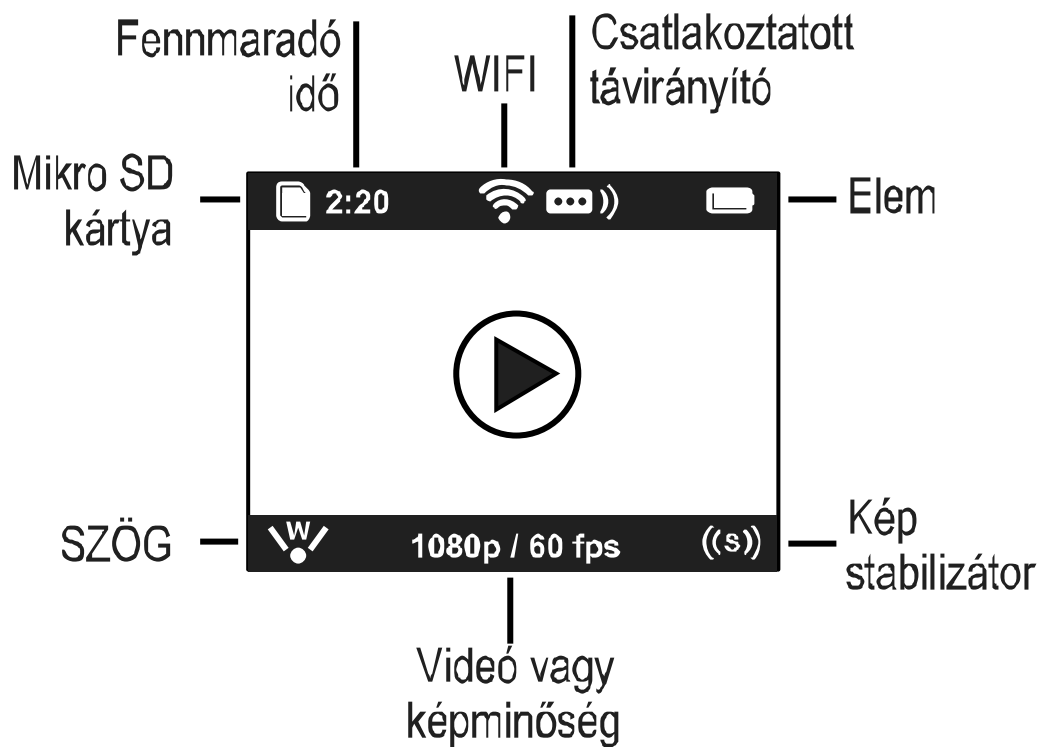

MENÜ

ÁLTALÁNOS BEÁLLÍTÁSOK

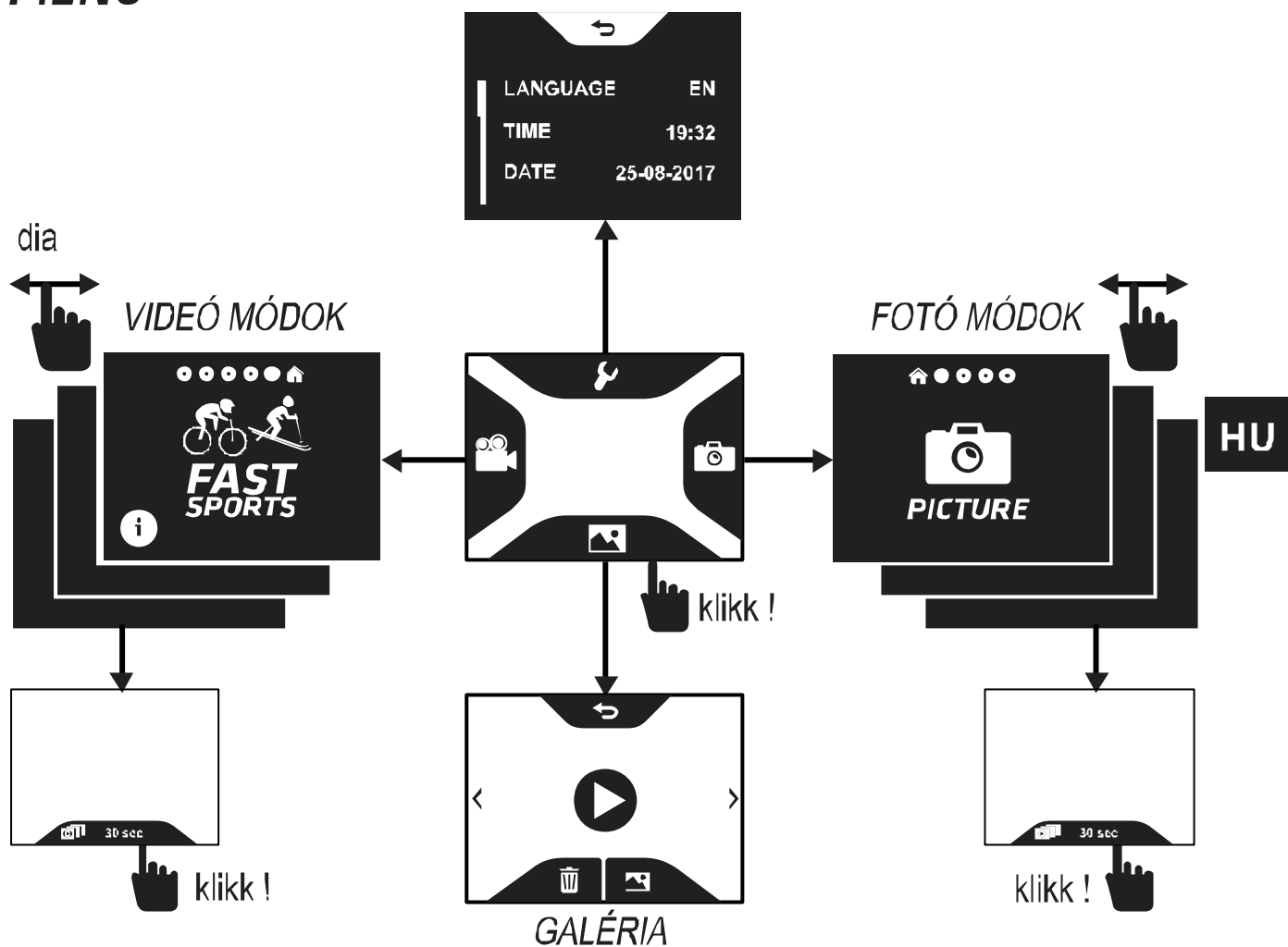

VIDEÓ MÓDOK



Optimalizált beállítások dinamikus sportokhoz
1080p (Teljes HD) 60fps
széles látószög és stabilizáló



Optimalizált beállítások lassú sportokhoz
1080p (Teljes HD) 30fps
széles látószög

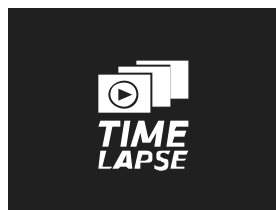

Timelapse videó
1kép / 2 mp, 5 mp, 10 mp, 30 mp, 60 mp, 300 mp



Lassított felvétel videó
720p / 120fps

 CUSTOM	FEL- BONTÁS	NTSC (fps)	PAL (fps)	Látómező
	4K 2.7K 2.7K (4:3) 1440P 1080P 960P 720P	15 24/30 30 24/30 24/30/60 60 30/60/120	12.5 24/25 25 24/25 24/25/50 50 25/50/120	W : Széles W/M : Széles/Közepes W : Széles W : Széles W/M/N : Széles/Közepes/Szűk W : Széles W/M/N : Széles/Közepes/Szűk

FOTÓ MÓDOK

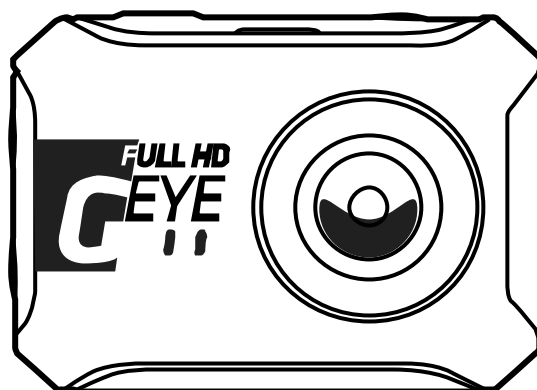

Klasszikus fotó
 16 MP, 12 MP, 8
 MP, 5 MP

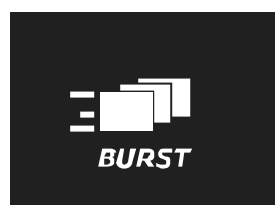

Tört fotók
 x30 kép/1 mp, 2 mp,
 3 mp, 6 mp
 x10 kép/1 mp, 2 mp,
 3 mp
 x5 kép/mp
 x3 kép/mp

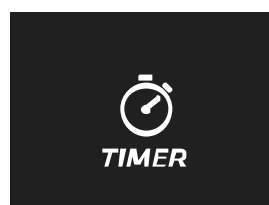

Időzítő
 1 mp, 3 mp, 5 mp,
 10 mp, 30 mp

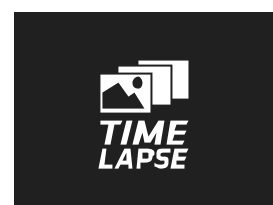

Timelapse fotó
 1 fotó / 2mp, 5mp,
 10mp, 30mp, 60mp,
 300mp

ÁLTALÁNOS BEÁLLÍTÁS(OK)

HANG

On
Off

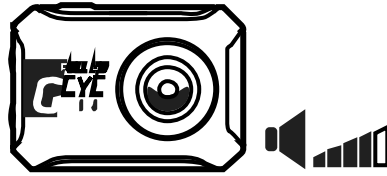

LEDEK

On
Off

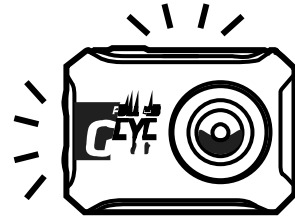

FORGATÁS

FEL
LE
AUTO

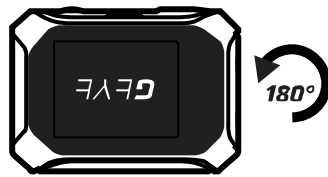

**LCD
STANDBY**

On
Off

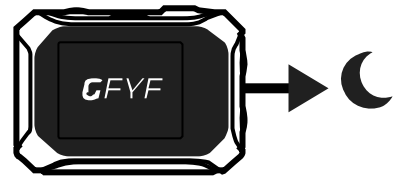

HU

AUTO On/Off

On
Off

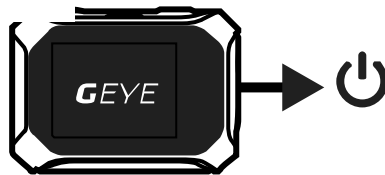

ÁTTEKINTÉS

On
Off

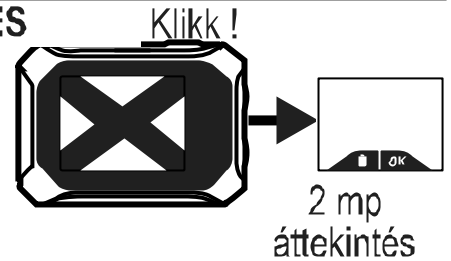

ÁLTALÁNOS BEÁLLÍTÁSOK (2/3)

UTOLSÓ MÓD

On
Off

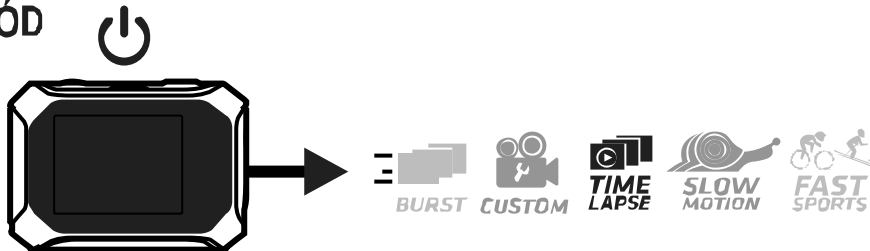

Aktiválja a kamerát az utolsó videó/fotó módban

FAST REC :

On
Off

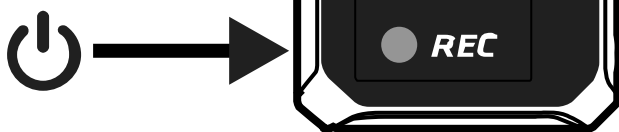

Aktiválja a kamerát és indítsa el a videót/fotót

SZÜNET

On
Off



Aktiválja a felvétel szüneteltetése funkciót

ÁLTALÁNOS BEÁLLÍTÁSOK (3/3)

TORZÍTÁS :

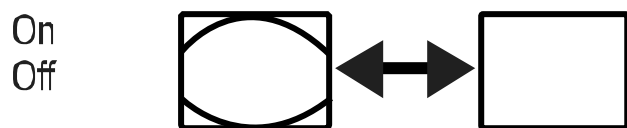

ISMÉTLÉSE

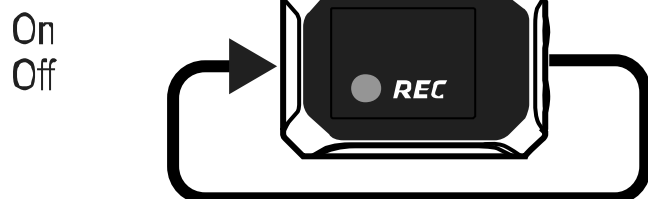

KIMENET

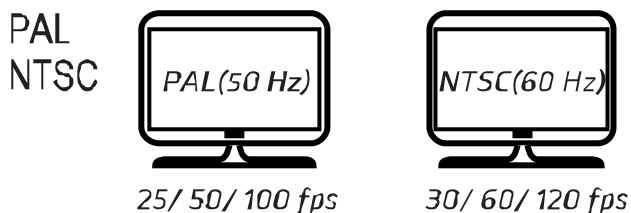

ÖSSZES NULLÁZÁSA

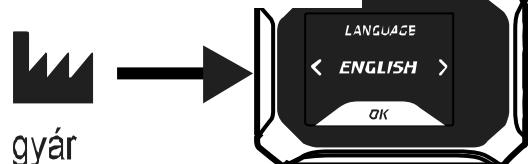

SD FORMÁTUM

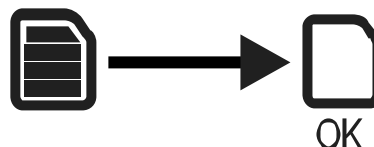

MEGNÉZ/ELLENŐRIZ

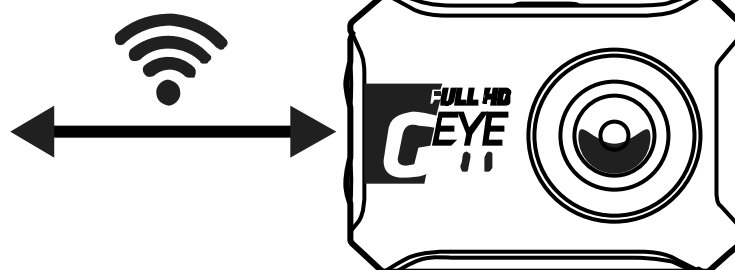

Nézze meg, konfigurálja és ellenőrizze a fényképezőgépét az okostelefonon elérhető wifi segítségével.

Aktiválja a fényképezőgépe wifijét és kövesse az alkalmazás utasításait.

TÁVIRÁNYÍTÓ (OPCIONÁLIS)

Párosítsa a távirányítót az eljárást követve, miután aktiválta a TÁVIRÁNYÍTÓ funkciót a fényképezőgép általános beállításainál.

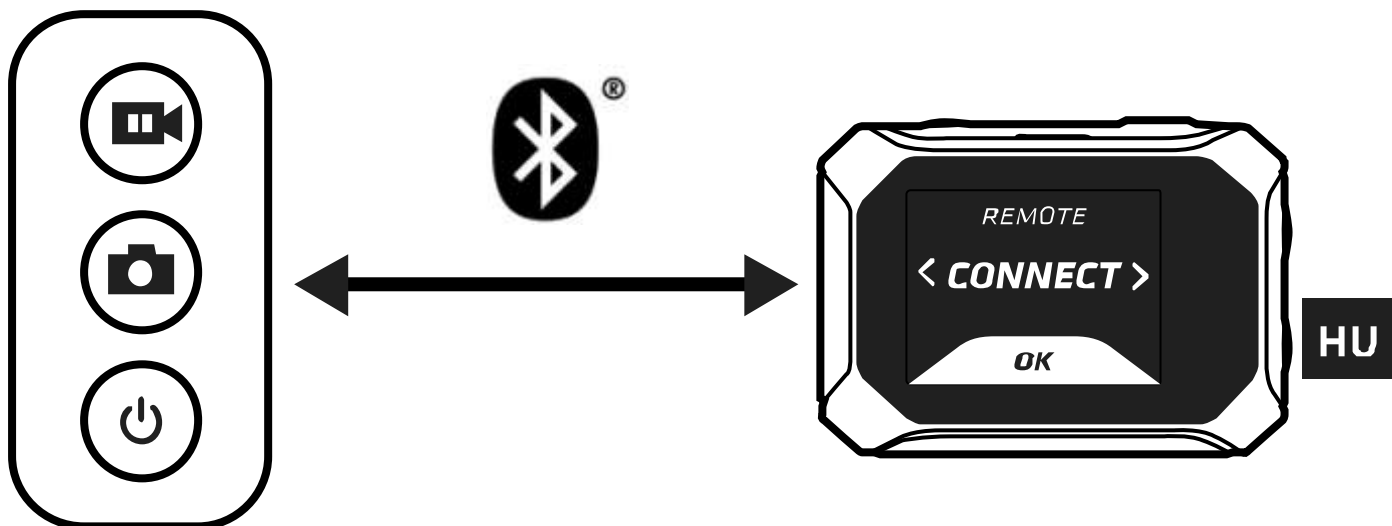

MEGTEKINTÉS TV-N

Egy mini HDMI kábel (opcionális) segítségével a fotó/videó tartalmak HD televízión is megtekinthetők.

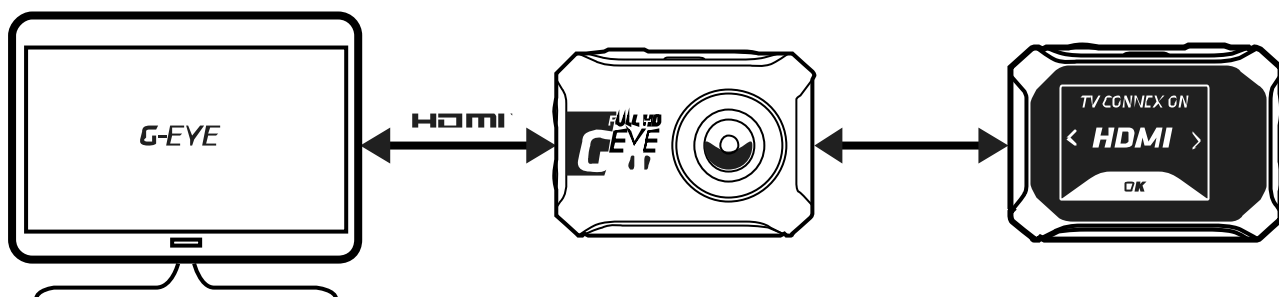

CSATLAKOZTASSA A KAMERÁT

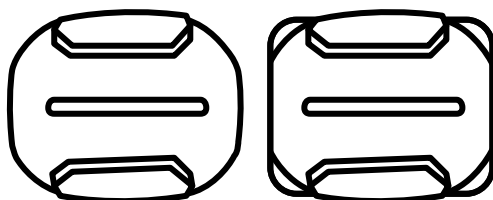

A felragasztandó részt csak tiszta, sima felületekre helyezze fel szobahőmérsékleten. A használat előtt várjon 24 órát.

MŰSZAKI SPECIFIKÁCIÓK

GEYE900 Súly és méretek:

Súly : 106g / 207g súlyú tok

Magasság : 50mm

Szélesség : 68mm

Mélység : 27mm / 36mm lencsével

GEYE900 típusú elem:

Li-ion elem, 1480mAh

Fő anyag : ABS

ÁLTALÁNOS TERMÉKBIZTONSÁG

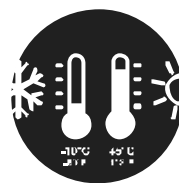

Óvatosan kezelje a terméket, ne ejtse le, illetve ne tegye ki komolyabb káros hatásnak. Vigyázat, a vízálló tok nélkül ez a termék nem vízálló. Ne érje víz a terméket, ne merüljön vízbe.

A nagyobb biztonság érdekében ne érintse meg a gombokat használat közben. A koncentráció elvesztése veszélyes lehet.

Ne szedje szét a terméket, mert megsérülhet és ezáltal elveszti szavatosságát.

Ha a terméket rendkívül hideg időjárási körülmények között használja (-10°C-nál hidegebb időben), az elem hatékonysága romlik és élettartama csökken.

KORLÁTOLT FELELŐSSÉG

A DECATHLON nem vállal felelősséget a magas kockázatú sportok során történő termék- használatból eredő balesetekért vagy sérülésekért. A DECATHLON külön szeretné felhívni a felhasználók figyelmét arra, hogy ha veszélyes körülmények között használjuk a terméket, fennáll a kockázat, hogy elveszíthetjük koncentrációképességünket.

Figyelem! A felhasználó felelősséget vállal a termékkel készített képekért, azok megosztásáért és közzétételéért.

EK MEGFELELŐSÉGI TANÚSÍTVÁNY

A DECATHLON ezennel kijelenti, hogy a G-EYE 900 eszköz megfelel a 2014/53/EU irányelv lényegi követelményeinek és más fontos előírásainak.

Az EK megfelelőségi nyilatkozatot a következő weboldalon lehet megtekinteni :

www.geonaute.com/en/ec-declaration-conformity

ÚJRAHASZNOSÍTÁS

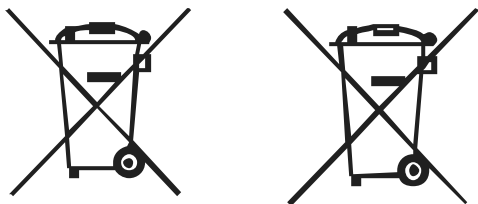

VEGYE FEL VELÜNK A KAPCSOLATOT

Lépjön velünk kapcsolatba a
www.customercare.geonaute.com oldalon

HU

DESCRIERE



apăsare scurtă:
Pornește/Întrerupe funcția video

apăsare lungă:
Pornește aparatul foto și începe/oprește înregistrarea



apăsare scurtă:
Face o fotografie/Face o fotografie în timpul videoclipului

apăsare lungă:
Pornește aparatul foto și face o fotografie



apăsare lungă:
On/Off



apăsare lungă:
WIFI On/Off

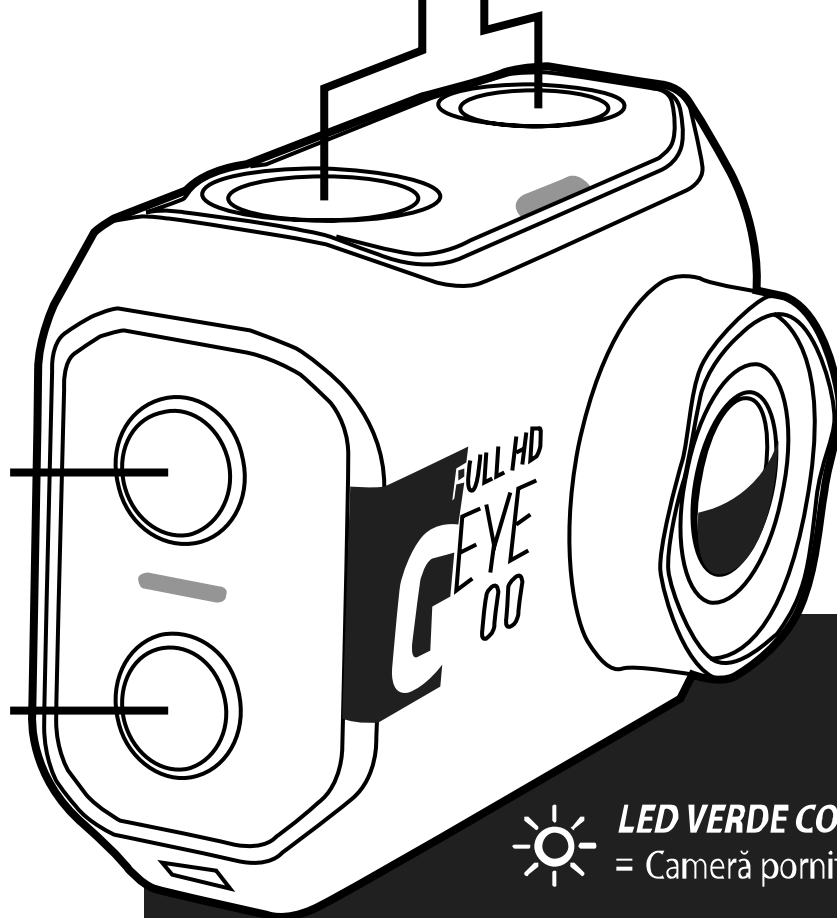

LED VERDE CONTINUU

= Cameră pornită



LED ROȘU CONTINUU

= Videoclip întrerupt sau cameră în curs de încărcare.

LED ROȘU INTERMITENT

= Funcție foto sau înregistrare video în curs ori baterie descărcată.

PRIMII PAȘI

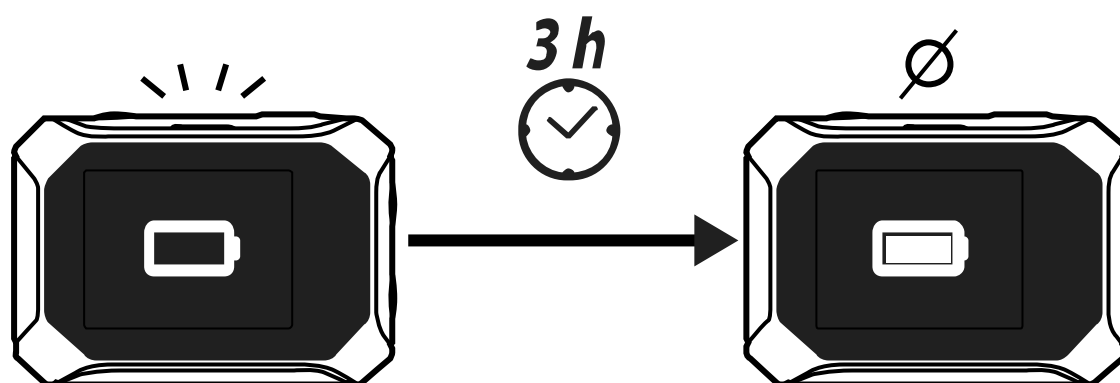
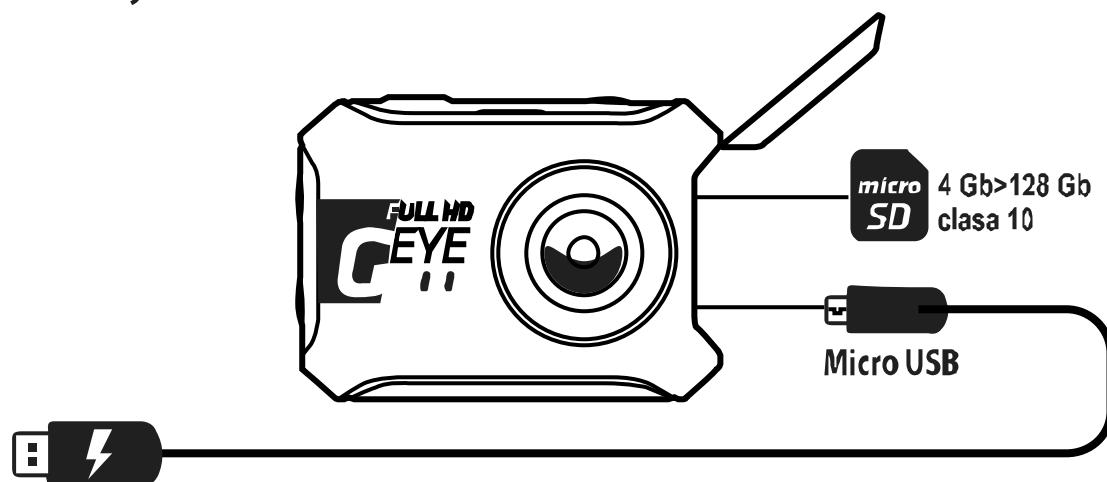

RO

UTILIZARE CU CARCASĂ ETANȘĂ

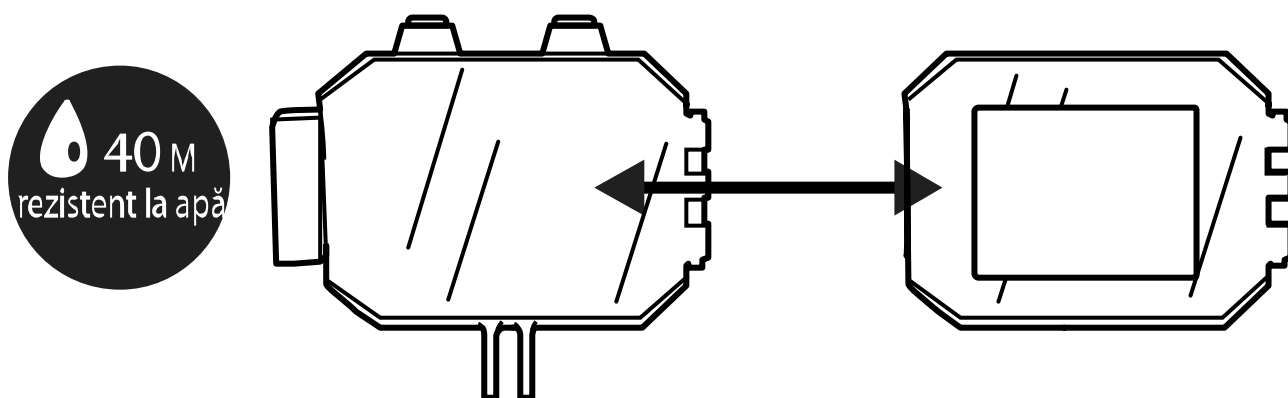

- Ușă spate standard (plină): etanșeitate până la 40 m
Pentru a garanta o etanșeitate perfectă, este important să păstrați garnitura de etanșeitate curată.
A se clăti cu apă curată.
- Ușă spate cu perforații: pentru medii uscate și fără praf:
acces la ecranul tactil și funcție de înregistrare audio mai performantă.

SCHIMBAREA UȘII SPATE:

Deschideți complet carcasa și trageți de ușă într-o parte, până când iese de la loc.

Aliniați noua ușă cu balamaua și închideți ușa din nou, până când intră la loc perfect.



Utilizați un produs anti-aburire (accesoriu vândut separat la DECATHLON)

MENIU

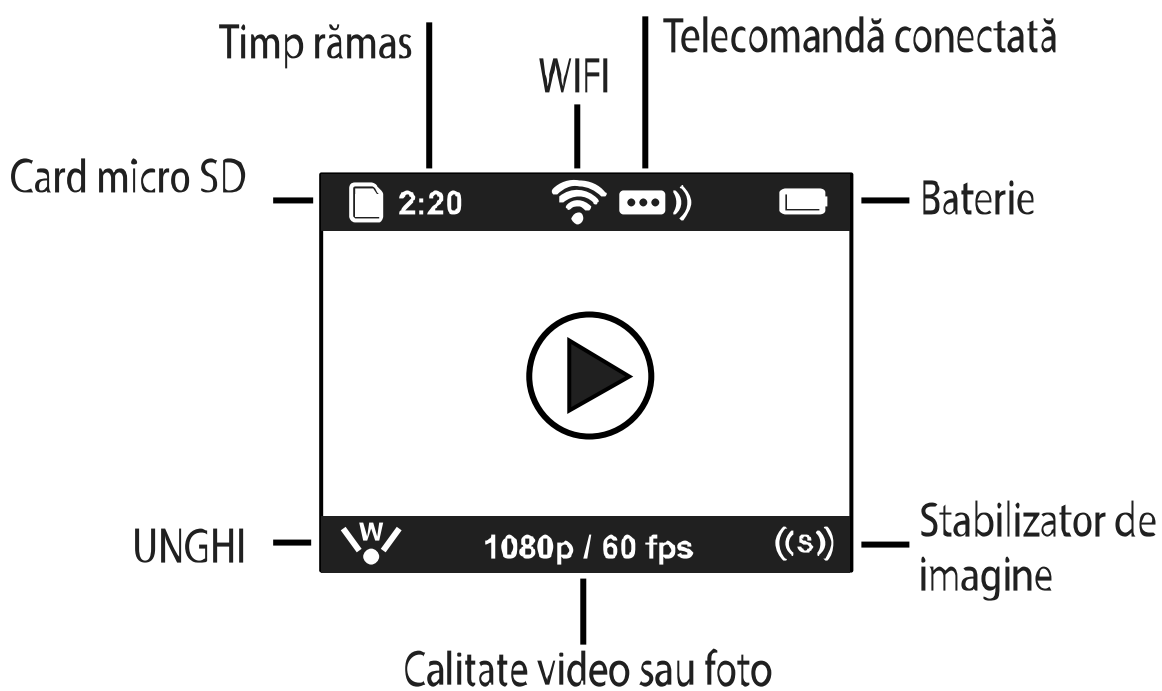

MENIU

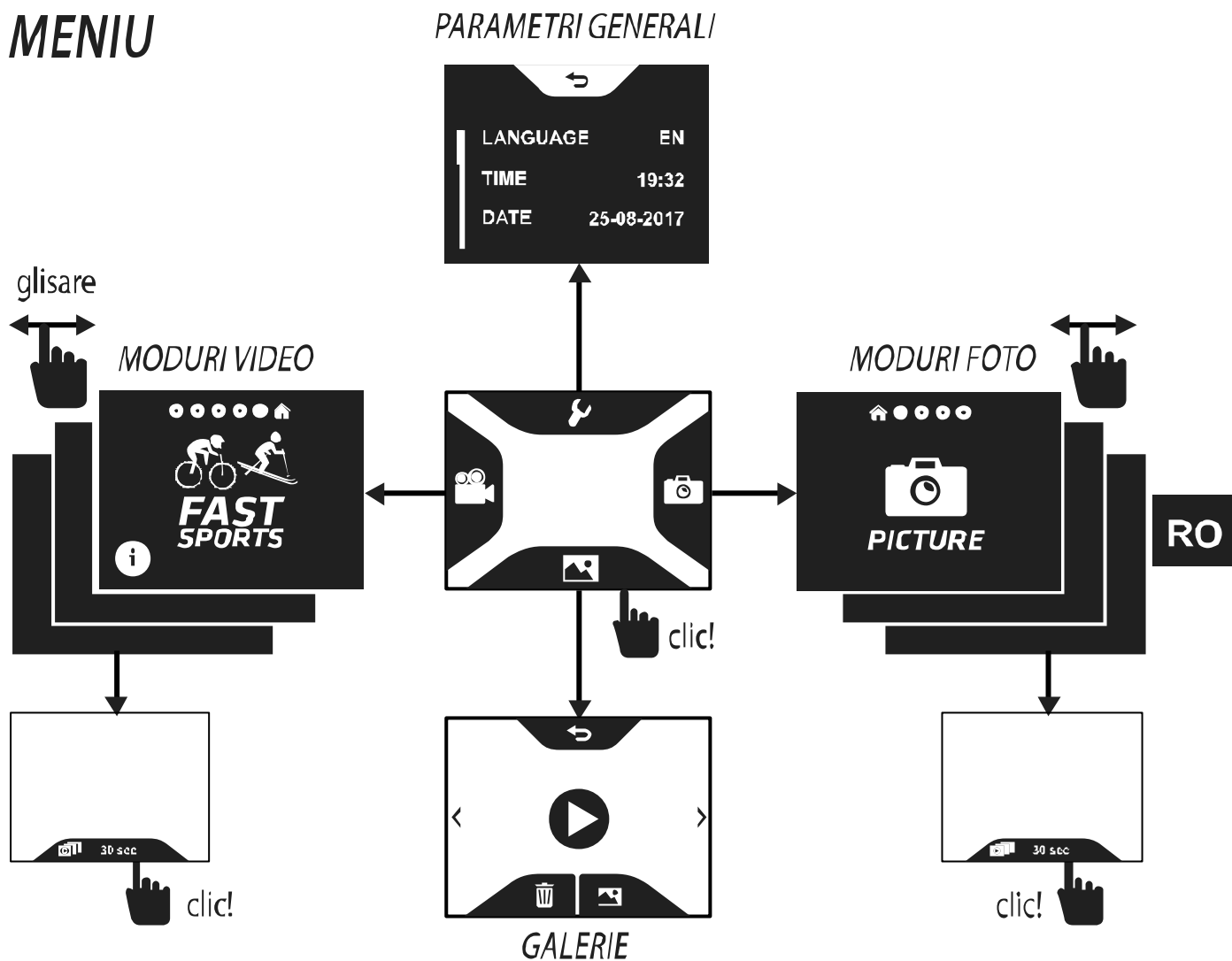

MODURI VIDEO



Reglaje optimizate pentru sporturi dinamice
1080 p (Full HD)
60 fps
unghi larg și stabilizator



Reglaje optimizate pentru sporturi lente
1080 p (Full HD)
30 fps
unghi larg

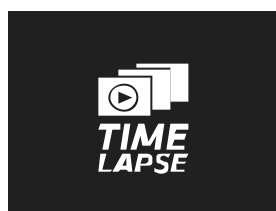

Funcție video timelapse
1 fotografie / 2 sec., 5 sec., 10 sec., 30 sec., 60 sec., 300 sec.



Filmare cu încetinitorul
720 p / 120 fps

	REZOLUȚIE	NTSC (fps)	PAL (fps)	Câmp vizual
 CUSTOM	4K	15	12.5	W : Larg
	2.7K	24/30	24/25	W/M : Larg/Mediu
	2.7K (4:3)	30	25	W : Larg
	1440P	24/30	24/25	W : Larg
	1080P	24/30/60	24/25/50	W/M/N : Larg/Mediu/Îngust
	960P	60	50	W : Larg
	720P	30/60/120	25/50/120	W/M/N : Larg/Mediu/Îngust

MODURI FOTO

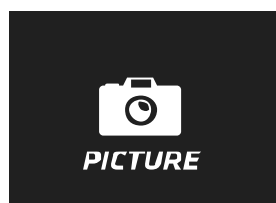
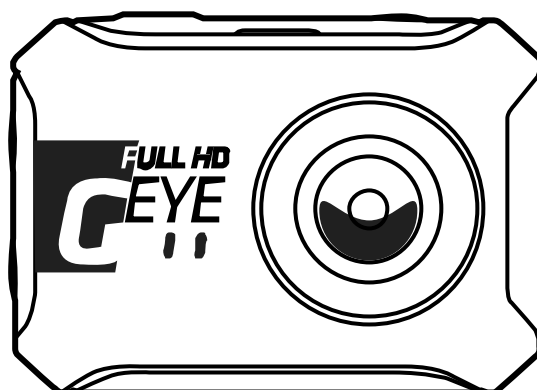

Fotografie clasică
**16 MP, 12 MP, 8 MP,
 5 MP**

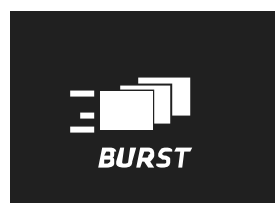

Fotografii în rafală
**x 30 de imagini / 1
 sec., 2 sec., 3 sec.,
 6 sec.**
**x 10 imagini / 1 sec.,
 2 sec., 3 sec.**
x 5 imagini/sec.
x 3 imagini/sec.

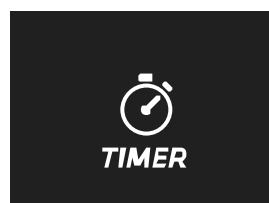

Temporizator
**1 sec., 3 sec., 5 sec.,
 10 sec., 30 sec.**

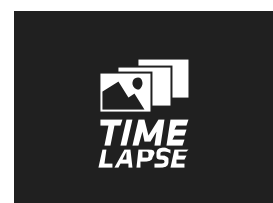

Funcție foto timelapse
**1 fotografie / 2 sec., 5
 sec., 10 sec., 30 sec.,
 60 sec., 300 sec.**

PARAMETRI GENERALI (1/3)

SUNET

On
Off

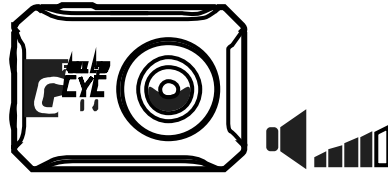

LED-URI

On
Off

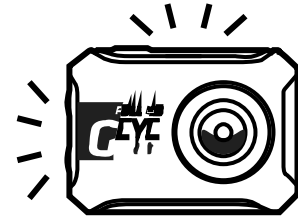

ROTIRE

SUS
JOS
AUTO

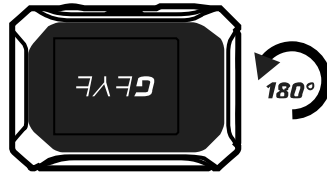

VEGHE LCD

On
Off

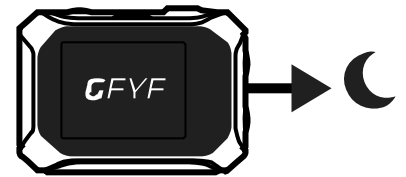

2 min. în
modul
automat

AUTO On/Off

On
Off

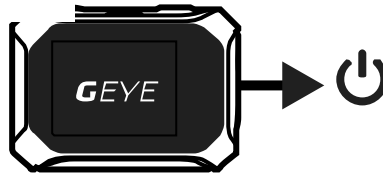

10 min.
în modul
automat

CONSULTARE

On
Off

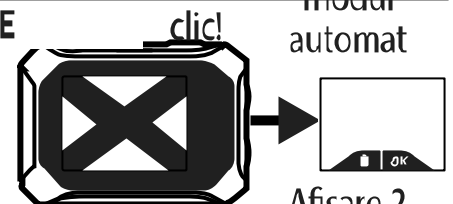

Afișare 2
secunde

RO

PARAMETRI GENERALI (2/3)

ULTIMUL

MOD

On
Off

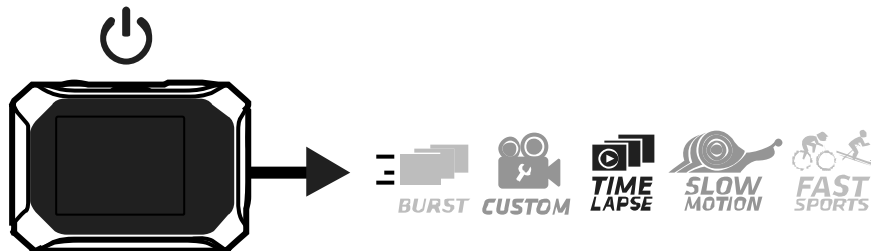

Activează aparatul foto în ultimul mod video/foto

FAST REC:

On
Off

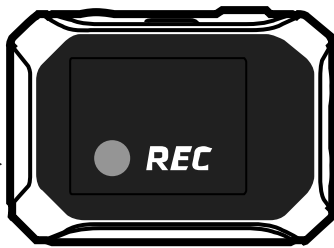

Activează aparatul foto și pornește funcția video/foto

PAUZĂ

On
Off

clic!

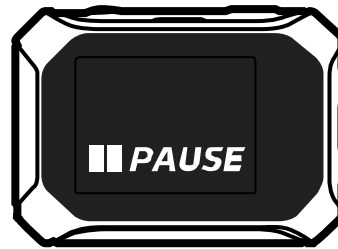

Activează funcția de întrerupere a înregistrării

PARAMETRI GENERALI (3/3)

DEFORMARE:

On
Off

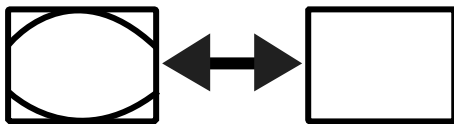

VIDEO ÎN BUCLĂ

On
Off

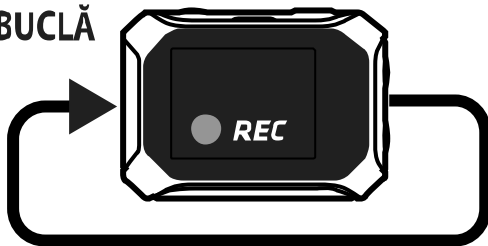

IEȘIRE

PAL
NTSC

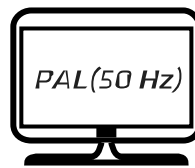

25/ 50/ 100 fps



30/ 60/ 120 fps

RESETARE GLOBALĂ

fabrică



FORMATARE SD



OK!

AFIȘARE/OPERARE

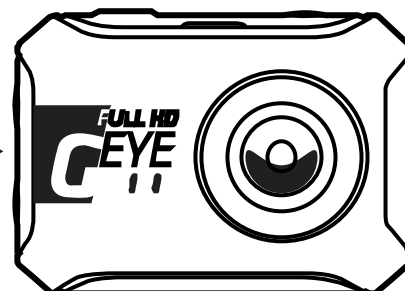

RO

Afișați, configurați și operați aparatul foto prin conexiunea wifi a smartphone-ului.

Activați conexiunea wifi a aparatului foto și a smartphone-ului, apoi urmați instrucțiunile din aplicație.

TELECOMANDĂ (OPȚIONALĂ)

Împerecheați telecomanda, urmând procedura, după ce ați activat funcția REMOTE (TELECOMANDĂ) în parametrii generali ai aparatului foto.

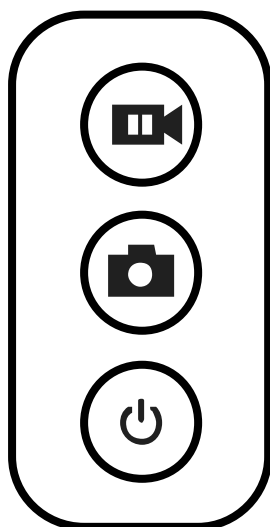

AFIȘARE TV

Cu ajutorul unui cablu mini-HDMI (opțional), puteți difuza conținutul foto/video pe un televizor HD.

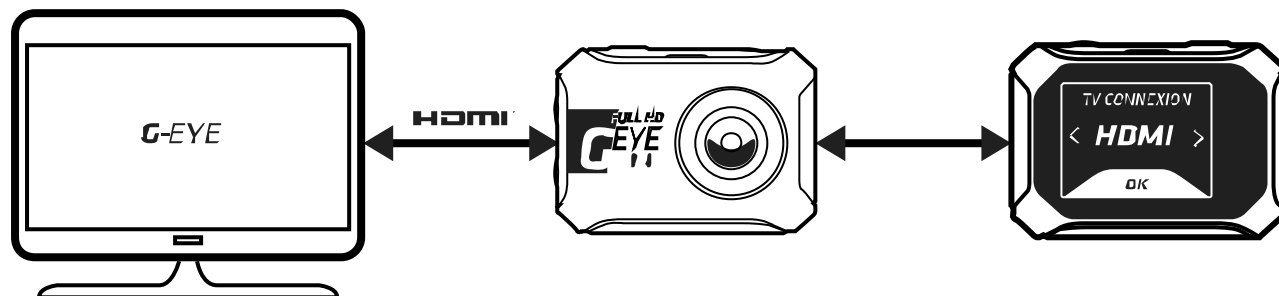

FIXAREA APARATULUI FOTO

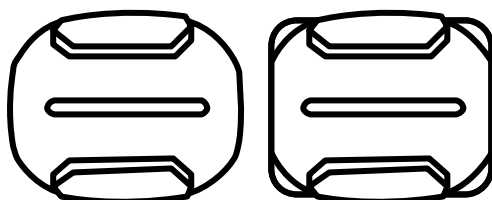

Fixați suporturile adezive pe suprafețe curate și netede, doar la temperatura camerei. Așteptați 24 de ore înainte de utilizare.

SPECIFICAȚII TEHNICE

Greutatea și dimensiunile aparatului GEYE900: Tipul bateriei GEYE900:

Greutate: 106 g/207 g cu carcasa

Baterie cu li-ion , 1.480 mAh

Înălțime: 50 mm

Material principal: ABS

Lățime: 68 mm

Adâncime: 27 mm/36 mm cu obiectivul

SIGURANȚA GENERALĂ A PRODUSULUI



Manipulați dispozitivul cu grijă, nu îl scăpați pe jos și nu îl expuneți la impacturi violente. Atenție! Acest produs nu este rezistent la apă fără carcasa rezistentă la apă. Nu îl expuneți la