

ONCOACH900/900HR

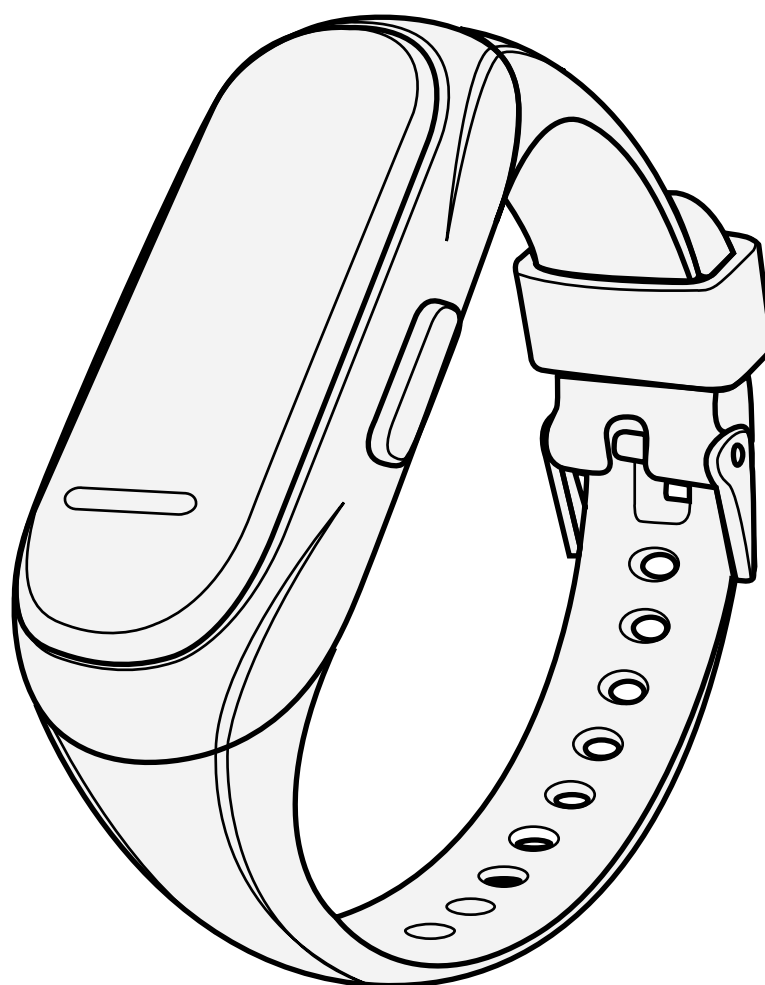

Kalenji - *newfeel*

- EN
- FR
- ES
- DE
- IT
- NL
- PT
- PL
- HU
- RO
- SK
- CS
- SV
- BG
- HR
- SL
- EL
- TR
- UK
- LT
- SR
- RU
- AR
- FA

CONTENTS

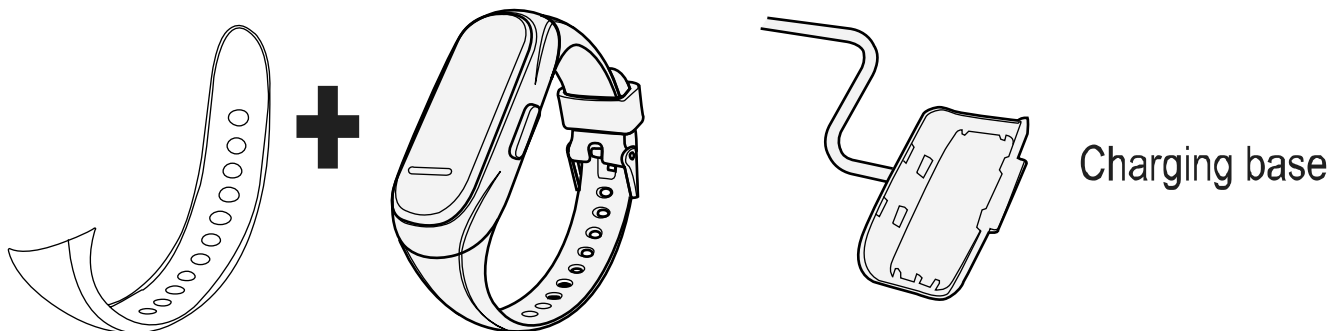

FIRST USE

• INTUITIVE HELP

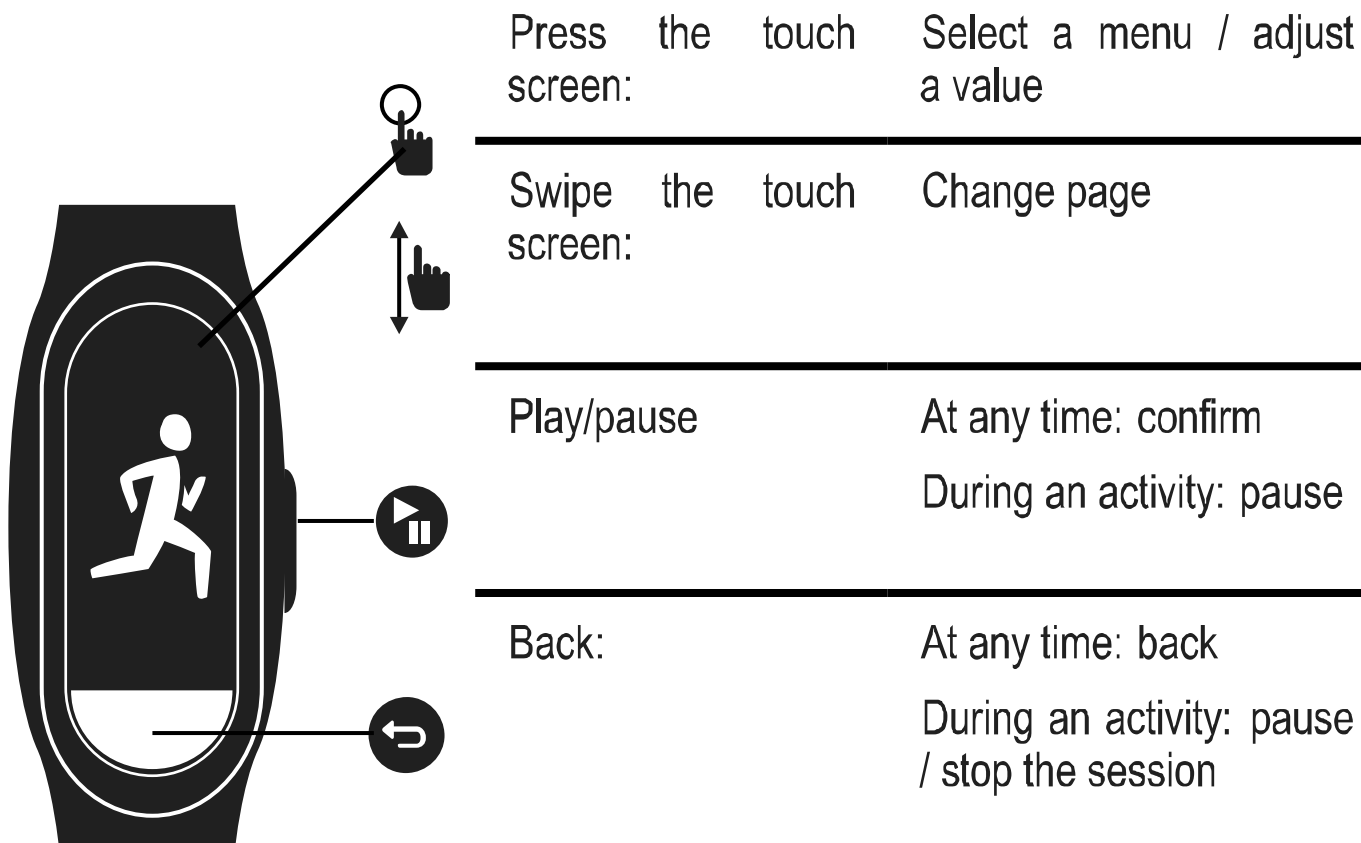

• CHARGING YOUR ONCOACH900/900 HR



Before first use, we recommend you fully charge your product:

- Attach the charger to your Oncoach900/900 HR
- Fully charge the watch by connecting it to a USB port on your computer or a 5V - 1A USB adapter

• INITIAL SET-UP

Press and hold the  button for 3 seconds. Choose between manual (MANUAL) or smartphone settings (CONNECT). If you select the manual mode, you will always be able to connect your watch later from the main menu ► **SETTINGS** ► **CONNECT**

• MANUAL SETTINGS

Adjust the settings for language, date, gender, size, weight and age by increasing/decreasing the values by pressing the touch screen in the corresponding areas  / . Confirm the settings by pressing the  button

• SMARTPHONE SETTINGS

Download and launch the DECATHLON CONNECT app on Google Play (Android) or the App Store (iOS) or on supportdecathlon.com Create an account or connect to the app Follow the instructions on your phone to connect your ONcoach900/900 HR to the app. Once connected, your ONcoach900/900 HR adjusts automatically. Be sure to turn on the Bluetooth on your phone to make the connection.

WRIST HEART RATE MEASUREMENT (Oncoach900HR only)

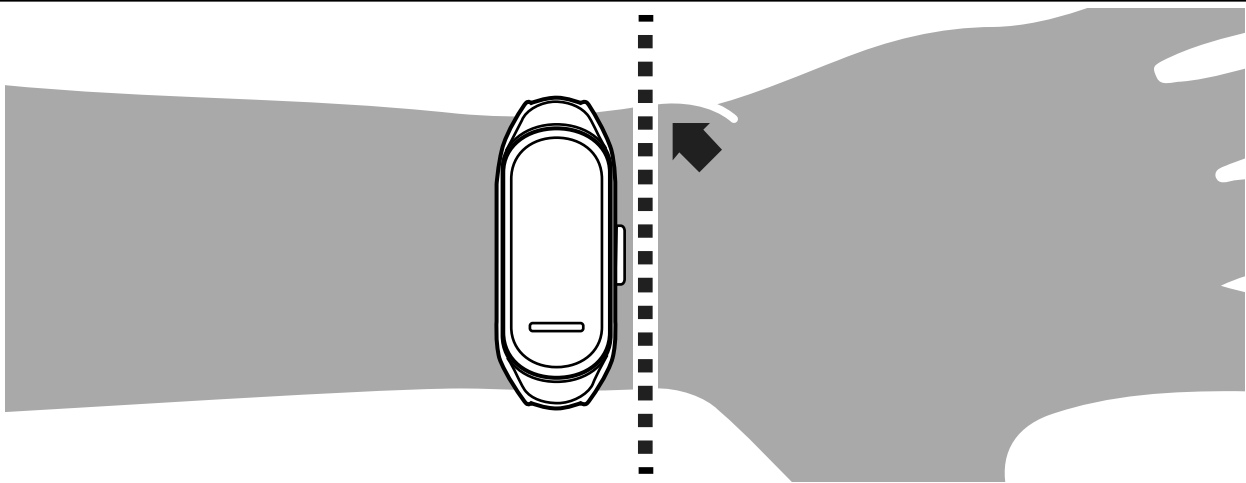







To ensure accurate measurement of your heart rate:



- Wear the watch with the dial on top of your wrist.
- The watch must be positioned away from the bone, in contact with your skin.
- Adjust the strap so that it is tight but does not bother you.
- The watch should not rotate or move on your wrist.



Note: measuring your heart rate with a wrist heart rate monitor (optical sensor) is optimum when practising sports with repetitive movements such as running or walking. It is advisable to use a heart rate belt for fitness sports (strength training)

START AND FOLLOW AN ACTIVITY

• START AN ACTIVITY

- Press  to access the main menu
- Access the ACTIVITY mode by swiping the  screen
- Select the ACTIVITY mode by pressing 
- Identify the sport that you want to practise by swiping the  screen
- Select the sport that you want to practise by pressing 
- Press  to start the activity

For a running activity, the ONcoach900/900HR will offer you the chance to set yourself a time goal. This goal is automatically increased by 5 minutes each time you reach it. Adjust the goal by touching the / buttons on the screen and confirm with 

- **CHANGE SCREEN DURING AN ACTIVITY** : Swipe the  screen
- **PAUSE** : Press 
- **STOP THE ACTIVITY** :

When paused, press . Confirm that you want to stop the session, by pressing on the screen. Choose if you want to save the session, by selecting the option on the screen.

MEASURE AND VIEW YOUR DAILY ACTIVITY

The ONcoach900/900HR continuously and automatically measures your daily walking activity as well as your heart rate and your resting heart rate. (Oncoach900HR only) You can view this information throughout the current day by selecting the MY DAY menu from the main menu.



TRANSFER YOUR DATA TO YOUR SMARTPHONE

The transfer of data from your ONcoach900/900HR is done automatically when the DECATHLON CONNECT app is opened. For this, you must ensure that:







- Bluetooth is activated on your phone
- your ONcoach900/900HR is already connected to the app

SETTINGS

To access the settings:

- Press  to access the main menu
- Access the SETTINGS mode by swiping the  screen
- Select the SETTINGS mode by pressing 

• ALARM









- Touch the Alarm screen to activate the alarm
- Adjust the alarm hour by touching the / buttons on the screen and confirm with 
- Adjust the alarm minutes by touching the / buttons on the screen
- Confirm the alarm minutes with 
- To deactivate the alarm, touch the ALARM screen

• SILENT MODE







When it is deactivated, touch the  screen to activate the silent mode.

When it is activated, touch the  screen to deactivate the silent mode.

• Time



- From the SETTINGS menu, press  to access the Time menu.
- Adjust the hour by touching the / buttons on the screen and confirm with 
- Adjust the minutes by touching the / buttons on the screen and confirm with 
- Adjust the format by touching the screen and confirm with 

• DATE

- From the SETTINGS menu, swipe the screen to go to the DATE menu. Press  to access the DATE menu
- Adjust the year by touching the / buttons on the screen and confirm with 
- Adjust the month by touching the / buttons on the screen and

confirm with 

• USER



- From the SETTINGS menu , swipe the screen to go to the User menu. Press  to access the User menu.
- Adjust the size by touching the  buttons on the screen and confirm with 
- Adjust the weight by touching the

• Connect

- The CONNECT mode allows you to connect your product to a smartphone.
- Download and launch the DECATHLON CONNECT app on Google Play (Android) or the App Store (iOS) or on supportdecathlon.com
- Create an account or connect to the app
- Follow the instructions on your phone to connect your ONcoach900/900HR to the app.
- Once connected, your ONcoach900/900HR adjusts automatically.
- Be sure to turn on the Bluetooth on your phone to make the connection.

- Adjust the format by touching the screen and confirm with 

 buttons on the screen and confirm with 

- Adjust the gender by touching the screen and confirm with 
- Adjust the language by touching the  buttons on the screen and confirm with 

CHANGE THE BRACELET

EN

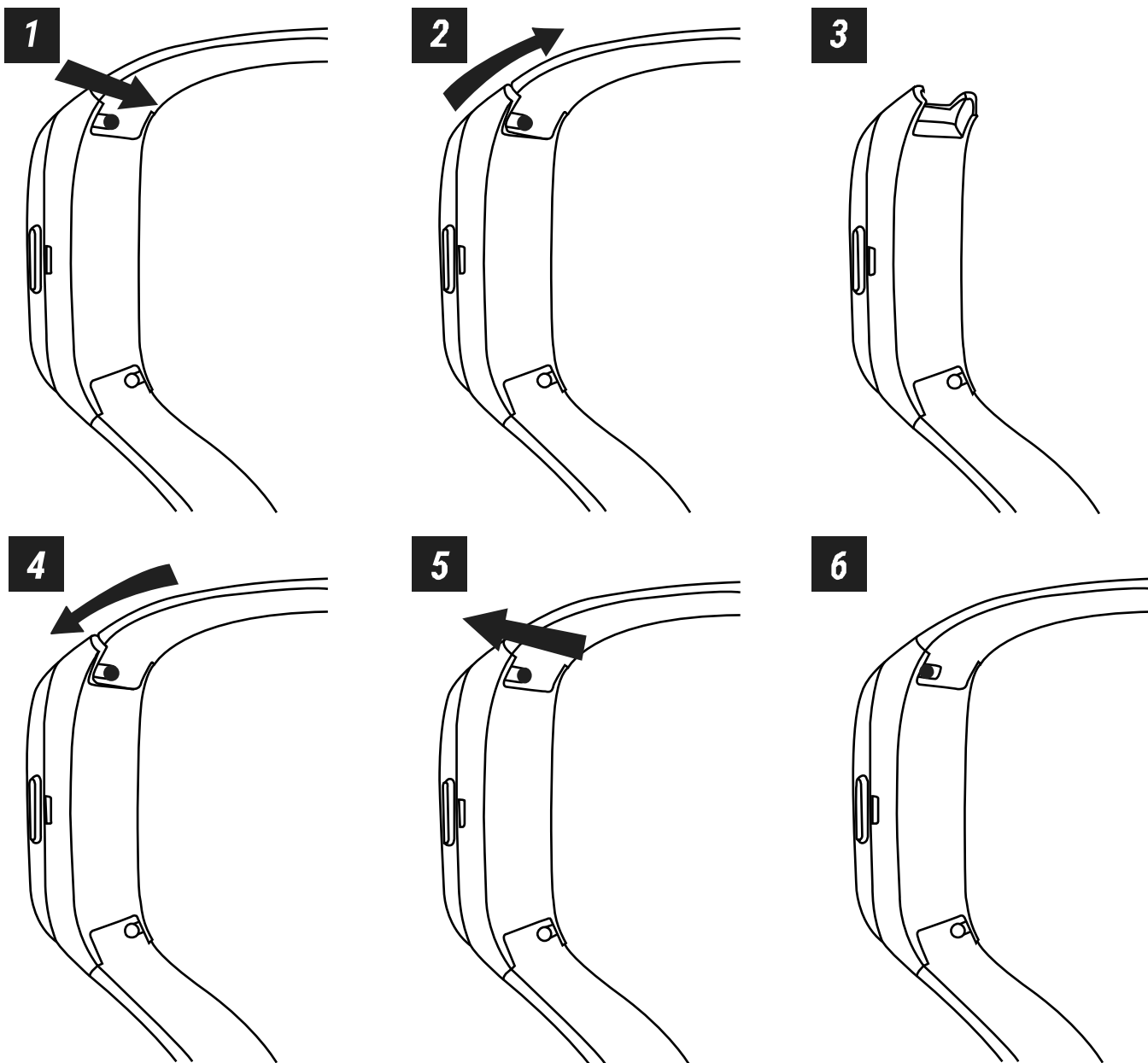

TECHNICAL SPECIFICATIONS

Weight: 24 g / 0.052 lb / 0.84 oz

Battery: Rechargeable lithium-ion

Waterproof design: 5 ATM, swimming resistant

Battery life: ONCOACH 900 : 12 days

ONCOACH 900HR : 4 days

Charging time: ONCOACH900/900HR : 2h30

FR

Strap: repairable, available in store

PRECAUTIONS FOR USE

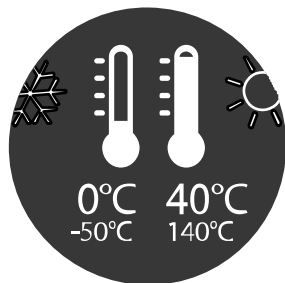

LEGAL NOTICES

This appliance contains batteries that are non-replaceable. DECATHLON hereby declares that the Oncoach900 and Oncoach900HR device complies with essential requirements and with other relevant stipulations of the 2014/53/EU directive. The EC compliance declaration is available at the following web link: ONCOACH 900 : https://support.decathlon.fr/oncoach900_doc / ONCOACH 900HR : https://support.decathlon.fr/oncoach900hr_doc

CONNECT

We would like your feedback on the quality, functionality and use of our products: supportdecathlon.com. We will reply as soon as possible.

FR

CONTENU

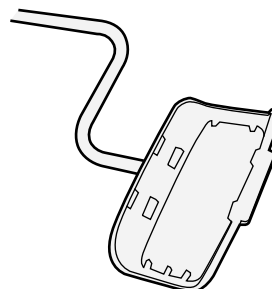
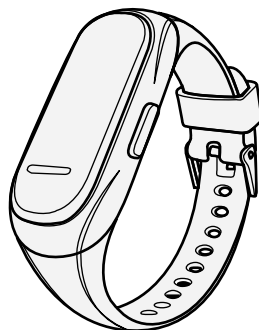
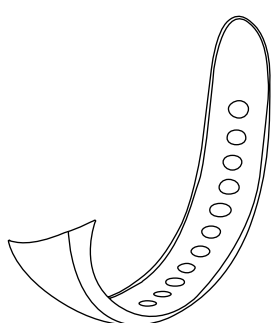

Base de
chargement

PREMIÈRE UTILISATION

• AIDE INTUITIVE

FR

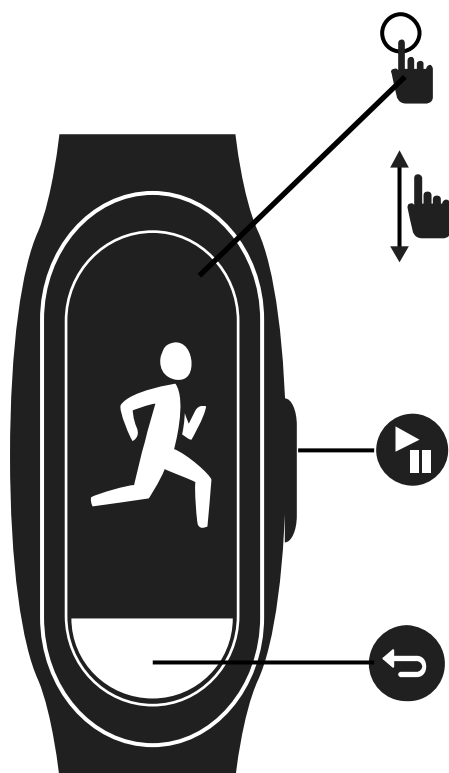

Appui écran tactile : Sélectionner un menu / régler une valeur

Balayer l'écran tactile : Changer de page

Play/pause A tout moment : valider
En activité : mettre en pause

Retour : A tout moment : retour
En activité : mettre en pause / arrêter la séance

• CHARGEMENT DE VOTRE ONCOACH900/900 HR

Avant la première utilisation, nous vous conseillons de charger complètement votre produit :

- Clipsez le chargeur à votre Oncoach900/900 HR en connectant au port USB de votre ordinateur ou sur un adaptateur USB 5V - 1A
- Chargez la montre complètement

• PREMIERS RÉGLAGES

Appuyez pendant 3 secondes sur le bouton . Choisissez entre les réglages manuels (MANUEL) ou par smartphone (CONNECT). Si vous sélectionnez le mode manuel, il vous sera toujours possible de connecter votre montre ultérieurement depuis le menu principal ► **REGLAGES** ► **CONNECT**

• RÉGLAGES MANUELS

FR

Réglez les paramètres de langue, date, genre, taille, poids, âge en incrémentant/décrémentant les valeurs par appui sur l'écran tactile sur les zones (+)/(-). Validez les réglages en appuyant sur le bouton 

• RÉGLAGES PAR SMARTPHONE

Téléchargez et lancez l'application DECATHLON CONNECT sur Google Play (Android) ou l'App Store (iOS) ou sur supportdecathlon.com Créez un compte ou connectez vous à l'application Suivez les instructions sur votre téléphone pour connecter votre ONcoach900/900 HR à l'application. Une fois connecté, votre ONcoach900/900 HR se règle automatiquement. Veillez à bien activer le bluetooth de votre téléphone pour effectuer la connexion.

MESURE DE LA FREQUENCE CARDIAQUE AU POIGNET (Oncoach900HR uniquement)

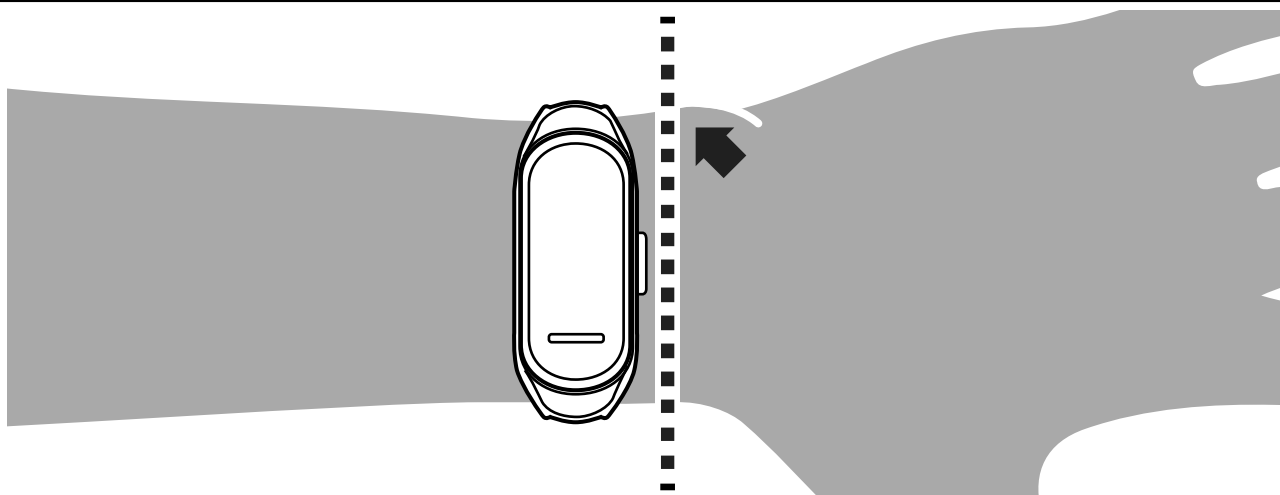

Pour garantir une mesure précise de votre rythme cardiaque :







- Portez la montre avec le cadran sur le dessus de votre poignet.
- La montre doit être positionnée après l'os, en contact avec votre peau.
- Réglez le bracelet de façon à ce qu'il soit serré mais ne vous gêne pas.
- La montre ne doit pas tourner ou bouger sur votre poignet.



Remarque : la mesure de la fréquence cardiaque avec un capteur cardiofréquence-mètre au poignet (capteur optique) est optimum lors d'une pratique sportive à mouvements répétitifs comme la course à pied, ou la marche. Il est conseillé d'utiliser une ceinture cardiaque pour les sports de fitness (musculature)

DÉMARRER ET SUIVRE UNE ACTIVITÉ

FR

• DÉMARRER UNE ACTIVITÉ

- Appuyez sur  pour ouvrir le menu principal
- Accédez au mode ACTIVITE en balayant l'écran 
- Sélectionnez le mode ACTIVITE en appuyant sur 
- Identifiez le sport que vous souhaitez pratiquer en balayant l'écran 
- Sélectionnez le sport que vous souhaitez pratiquer en appuyant sur 
- Appuyez sur  pour démarrer l'activité

Pour une activité de course à pied, le ONcoach900/900HR vous proposera de vous donner un objectif de temps. Cet objectif s'incrémente automatiquement de 5 minutes à chaque fois que vous l'atteignez. Réglez l'objectif en touchant les boutons / sur l'écran et validez avec 

- **CHANGER D'ÉCRAN PENDANT UNE ACTIVITÉ** : Balayez l'écran 
- **METTRE EN PAUSE** : Appuyez sur 
- **ARRÊTER L'ACTIVITÉ** :

Depuis la pause, appuyez sur . Validez l'arrêt de la séance en appuyant sur l'écran. Choisissez si vous souhaitez sauvegarder la séance en sélectionnant l'option sur l'écran.

MESURER ET VISUALISER VOTRE ACTIVITÉ QUOTIDIENNE

Les ONcoach900/900HR mesurent en permanence et de manière automatique votre activité quotidienne de marche ainsi que votre fréquence cardiaque et votre fréquence cardiaque au repos. (Oncoach900HR uniquement) Vous pouvez visualiser ces informations sur la journée en cours en sélectionnant le menu MA JOURNEE depuis le menu principal.



TRANSFÉRER VOS DONNÉES À VOTRE SMARTPHONE

Le transfert des données de votre ONcoach900/900HR se fait automatiquement à l'ouverture de l'application DECATHLON CONNECT. Pour cela vous devez vous assurer que :





REGLAGES

- le bluetooth est bien activé sur votre téléphone
- votre ONcoach900/900HR est déjà connecté à l'application

Pour accéder aux réglages :

- Appuyez sur  pour ouvrir le menu principal
- Accédez au mode REGLAGES en balayant l'écran  ↑
- Sélectionnez le mode REGLAGES en appuyant sur 

ALARME









- Touchez l'écran ALARME pour activer l'alarme
- Réglez l'heure de l'alarme en touchant les boutons   sur l'écran et validez avec 
- Réglez les minutes de l'alarme en touchant les boutons   sur l'écran
- Validez les minutes de l'alarme avec 
- Pour désactiver l'alarme touchez l'écran ALARME

MODE SILENCE









Lorsque celui-ci est désactivé, touchez l'écran  pour activer le mode silence.

Lorsque celui-ci est activé, touchez l'écran  pour désactiver le mode silence.











Heure

- Depuis le menu REGLAGES, appuyez sur  pour ouvrir le menu HEURE.
- Réglez l'heure en touchant les boutons   sur l'écran et validez avec 
- Réglez les minutes en touchant les boutons   sur l'écran et validez avec 
- Réglez le format en touchant l'écran et validez avec 

DATE

- Depuis le menu REGLAGES, balayez l'écran pour vous rendre sur le menu DATE. Appuyez sur  pour ouvrir le menu DATE
- Réglez l'année en touchant les boutons   sur l'écran et validez avec 
- Réglez le mois en touchant les boutons   sur l'écran et validez avec 
- Réglez le format en touchant l'écran et validez avec 

• UTILISATEUR

- Depuis le menu REGLAGES , balayez l'écran pour vous rendre sur le menu UTILISATEUR. Appuyez sur  pour ouvrir le menu UTILISATEUR.
- Réglez la taille en touchant les boutons / sur l'écran et validez avec 
- Réglez le poids en touchant les boutons / sur l'écran et validez avec 
- Réglez le genre en touchant l'écran et validez avec 
- Réglez la langue en touchant les boutons / sur l'écran et validez avec 

• Connect

- Le mode CONNECT vous permet de connecter votre produit à un smartphone.
- Téléchargez et lancez l'application DECATHLON CONNECT sur Google Play (Android) ou l'App Store (iOS) ou sur supportdecathlon.com
- Créez un compte ou connectez vous à l'application
- Suivez les instructions sur votre téléphone pour connecter votre ONcoach900/900HR à l'application.
- Une fois connecté, votre ONcoach900/900HR se règle automatiquement.
- Veillez à bien activer le bluetooth de votre téléphone pour effectuer la connexion.

CHANGER LE BRACELET

FR

1

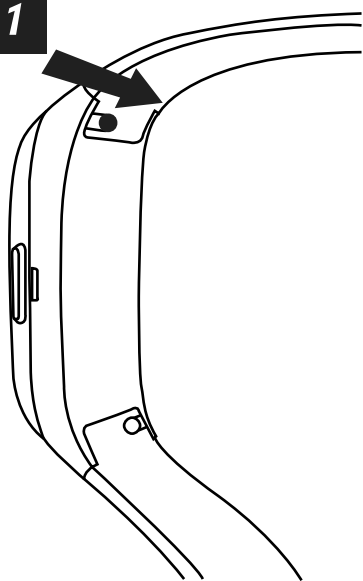

2

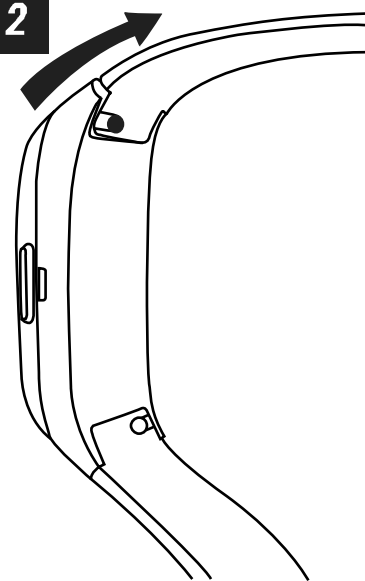

3

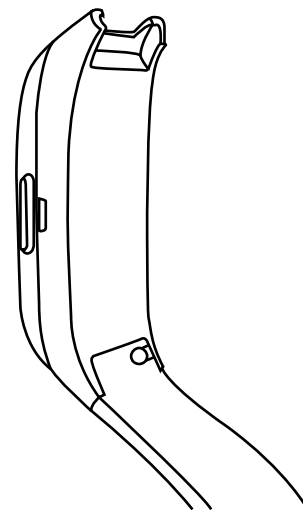

4

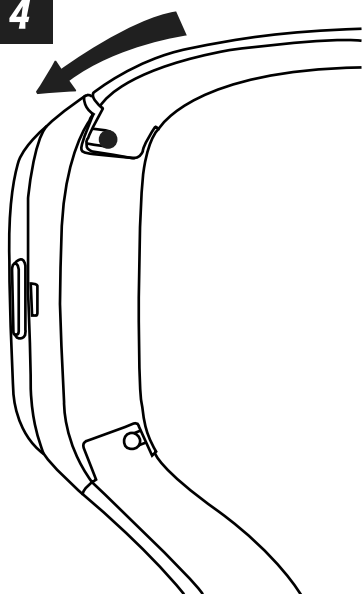

5

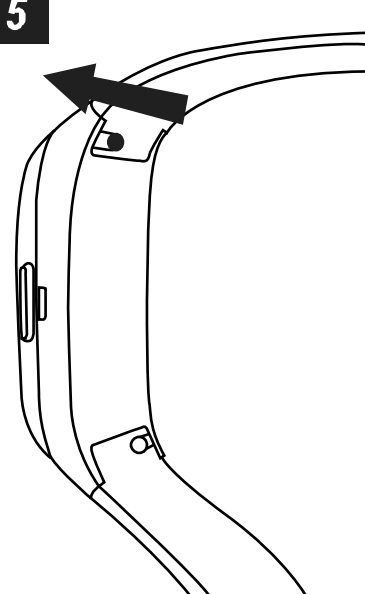

6

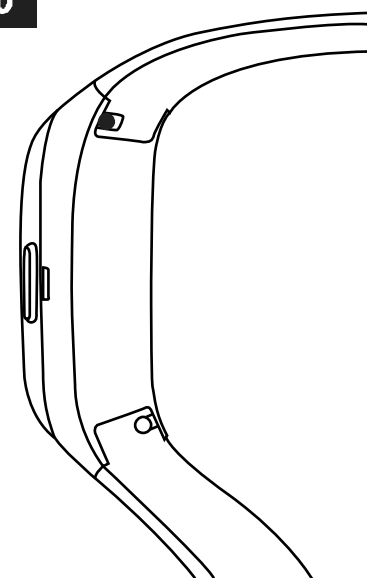

CARACTÉRISTIQUES TECHNIQUES

Poids : 24 g / 0,052 lb / 0,84 oz

Batterie : Rechargeable au lithium-ion

Étanchéité : 5 ATM, résistant à la nage

Autonomie : ONCOACH 900 : 12 jours

ONCOACH 900HR : 4 jours

Temps de charge : ONCOACH900/900HR : 2h30

Bracelet : réparable, disponible en magasin

PRÉCAUTIONS D'EMPLOI

ES

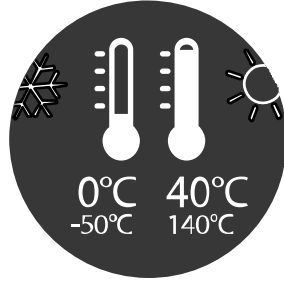

MENTIONS LÉGALES

Cet appareil contient des batteries qui ne peuvent pas être remplacées. Par la présente DECATHLON déclare que l'appareil Oncoach900 et Oncoach900HR est conforme aux exigences essentielles et autres dispositions pertinentes de la directive 2014/53/EU. La déclaration de conformité CE est disponible au lien internet suivant: ONCOACH 900 : https://support.decathlon.fr/oncoach900_doc / ONCOACH 900HR : https://support.decathlon.fr/oncoach900hr_doc

CONNECT

Nous sommes à l'écoute de vos remontées d'informations, quant à la qualité, la fonctionnalité ou l'usage de nos produits : supportdecathlon.com. Nous nous engageons à vous répondre dans les plus brefs délais.

ES

CONTENIDO

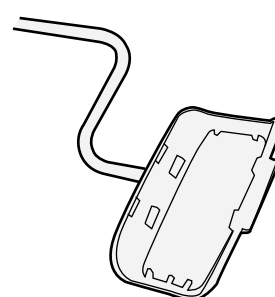
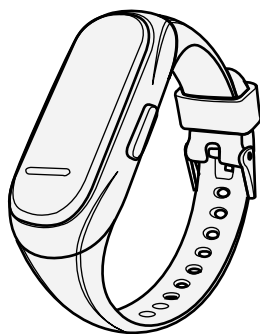
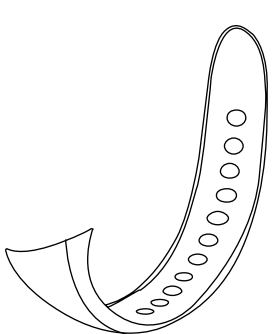

Base de carga

PRIMER USO

• AYUDA INTUITIVA

ES

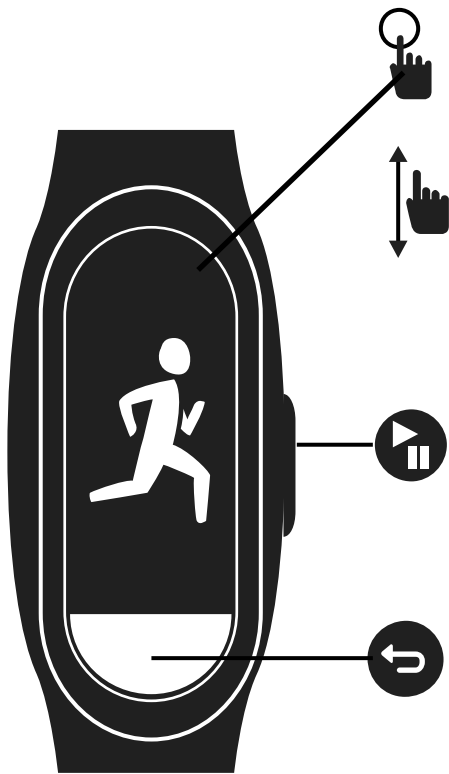

Soporte de pantalla táctil:

Seleccionar un menú/
establecer un valor

Deslizar el dedo sobre la pantalla táctil:

Cambiar de página

Reproducción/pausa

En todo momento: validar

Durante la actividad: poner en pausa

Volver:

En todo momento: retorno

Durante la actividad: poner en pausa/detener la sesión

• CARGA DE SU ONCOACH900/900 HR

Antes del primer uso, le aconsejamos cargar completamente su producto:

- Conecte el cargador a su Oncoach900/900 HR conectándolo al puerto USB de su ordenador o a un adaptador USB 5V - 1A
- Cargue el reloj completamente

• CONFIGURACIÓN INICIAL

Pulse el botón  durante 3 segundos. Elija entre la configuración manual (MANUAL) o a través del teléfono inteligente (CONECTAR). Si selecciona el modo manual, siempre podrá conectar su reloj más tarde desde el menú principal

► **CONFIGURACIÓN** ► **Conectar**

• CONFIGURACIÓN MANUAL

Ajuste los parámetros del idioma, la fecha, el sexo, la altura, el peso y la edad, incrementando/disminuyendo los valores tocando la pantalla táctil en las zonas \oplus/\ominus . Confirme la configuración pulsando el botón 

• CONFIGURACIÓN MEDIANTE TELÉFONO INTELIGENTE

Descargar e iniciar la aplicación DECATHLON CONNECT en Google Play (Android) o en la App Store (iOS) o en supportdecathlon.com Crear una cuenta o iniciar sesión en la aplicación. Siga las instrucciones de su teléfono para conectar su ONcoach900/900 HR a la aplicación. Una vez conectado, su ONcoach900/900 HR se ajusta automáticamente. Asegúrese de activar el bluetooth de su teléfono para realizar la conexión.

MEDICIÓN DE LA FRECUENCIA CARDÍACA EN LA PULSERA (Solo Oncoach900HR)

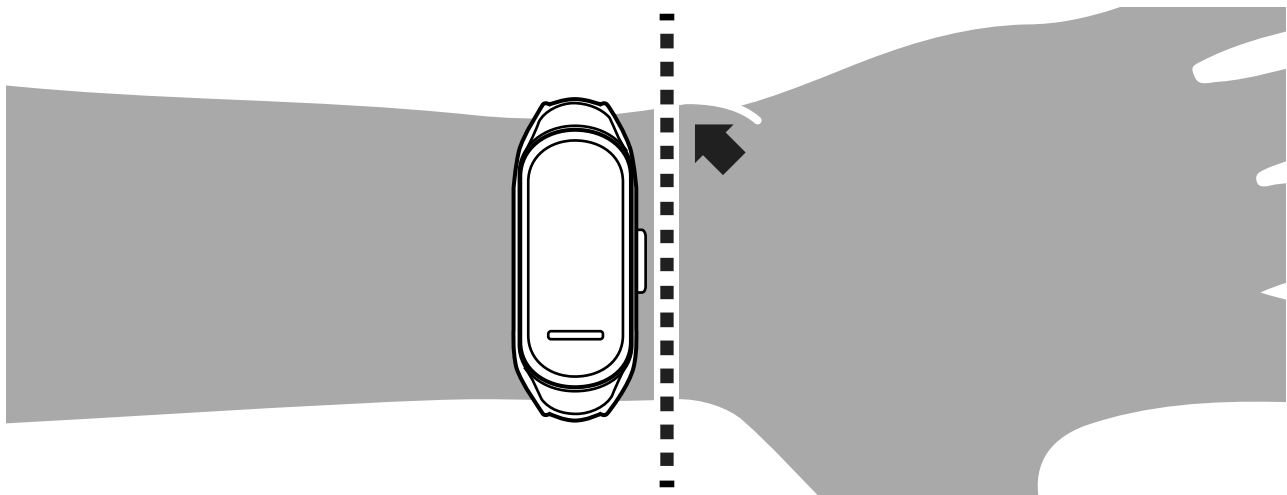

Para garantizar una medición precisa de la frecuencia cardíaca:







- Use el reloj con el dial en la parte superior de su muñeca.
- El reloj debe colocarse cerca del hueso, en contacto con la piel.
- Ajuste la correa para que esté apretada pero sin que moleste.
- El reloj no debe girar o moverse en la muñeca.



Nota: la medición de la frecuencia cardíaca con un monitor de ritmo cardíaco en la muñeca (sensor óptico) es óptima para la práctica de deportes repetitivos como correr o caminar. Es aconsejable utilizar un cinturón cardíaco para los deportes de fitness (culturismo)



COMENZAR Y SEGUIR UNA ACTIVIDAD

• INICIAR UNA ACTIVIDAD

ES

- Pulse  para abrir el menú principal
- Acceda al modo ACTIVIDAD deslizando la pantalla 
- Seleccione el modo ACTIVIDAD pulsando 
- Identifique el deporte que desea practicar deslizando la pantalla 
- Seleccione el deporte que desea practicar pulsando 
- Pulse  para iniciar la actividad

Para un evento de caminata, el ONcoach900/900HR le propondrá establecer un objetivo de tiempo. Este objetivo se incrementa automáticamente 5 minutos cada vez que lo alcanza. Ajuste el objetivo tocando los botones / en la pantalla y confirme con 

- **CAMBIAR PANTALLA DURANTE UNA ACTIVIDAD** : Deslice la pantalla 
- **PONER EN PAUSA** : Pulse 
- **DETENER LA ACTIVIDAD** :

Desde el modo de pausa, pulse . Confirme la detención pulsando en la pantalla. Elija si desea guardar la sesión seleccionando la opción en la pantalla.

MEDIR Y VISUALIZAR SU ACTIVIDAD DIARIA

El ONcoach900/900HR mide de forma continua y automática su actividad diaria cuando camina, así como su ritmo cardíaco y el ritmo cardíaco en reposo. (Solo Oncoach900HR) Puede ver esta información sobre el día actual seleccionando el menú MI DÍA desde el menú principal.

TRANSFERIR LOS DATOS A SU SMARTPHONE

La transferencia de datos desde su ONcoach900/900HR se realiza automáticamente cuando se abre la aplicación DECATHLON CONNECT. Para ello debe asegurarse de que:



- la conexión bluetooth esté habilitada en su teléfono conectado a la aplicación
- su ONcoach900 / 900HR ya está

CONFIGURACIÓN

Para acceder a la configuración:

- Pulse  para abrir el menú principal
- Acceda al modo CONFIGURACIÓN

• ALARMA





- Toque la pantalla Alarma para activar la alarma
- Ajuste la hora de la alarma tocando los botones / en la pantalla y confirme con 
- Ajuste los minutos de la alarma

• MODO SILENCIOSO





Cuando esté desactivado, toque la pantalla  para activar el modo silencioso.

Cuando esto esté activado, toque la pantalla  para desactivar el modo silencioso.

• Hora



- Desde el menú CONFIGURACIÓN, pulse  para abrir el menú Hora.
- Ajuste la hora tocando los botones / en la pantalla y confirme con 

• FECHA

- Desde el menú CONFIGURACIÓN, deslice la pantalla para ir al menú Fecha. Pulse  para abrir el menú Fecha, pulse
- Ajuste el año tocando los botones / y 

deslizando la pantalla 

- Seleccione el modo CONFIGURACIÓN pulsando 



tocando los botones / en la pantalla

- Valide los minutos de la alarma con 
- Para desactivar la alarma toque la pantalla Alarma

ES

• USUARIO

- Desde el menú CONFIGURACIÓN, deslice la pantalla para ir al menú Usuario. Pulse  para abrir el menú Usuario.

- Ajuste la altura tocando los botones / en la pantalla y confirme con 

- Ajuste el peso tocando los botones

• Conectar

- El modo Conectar le permite conectar su producto a un teléfono inteligente.

- Descargar e iniciar la aplicación DECATHLON CONNECT en Google Play (Android) o en la App Store (iOS) o en supportdecathlon.com

- Crear una cuenta o iniciar sesión en la aplicación



- Siga las instrucciones de su teléfono para conectar su ONcoach900/900HR a la aplicación.

- Una vez conectado, su ONcoach900/900HR se ajusta automáticamente.

- Asegúrese de activar el bluetooth de su teléfono para realizar la conexión.

/ en la pantalla y confirme con 

- Ajuste el sexo tocando la pantalla y confirme con 

- Ajuste el idioma tocando los botones / en la pantalla y confirme con 

CAMBIAR LA PULSERA

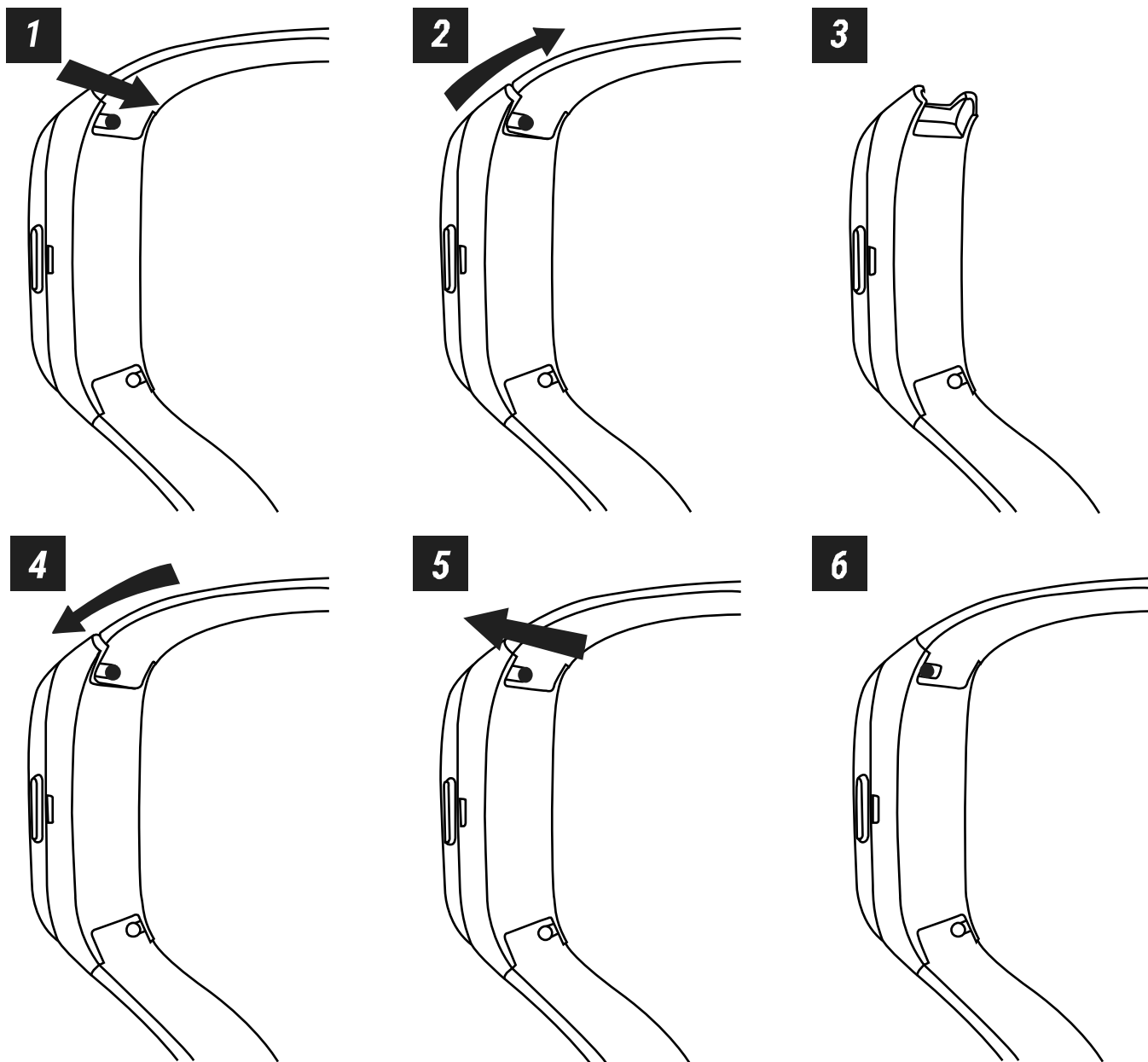

ES

CARACTERÍSTICAS TÉCNICAS

Peso: 24 g / 0,052 lb / 0,84 oz

Batería: Recargable de litio-ion

Impermeabilidad: 5 ATM, resistente al agua

Autonomía: ONCOACH 900 : 12 días

ONCOACH 900HR : 4 días

Tiempo de carga: ONCOACH900/900HR : 2h30

Correa: reparable, disponible en tiendas

PRECAUCIONES DE USO

DE

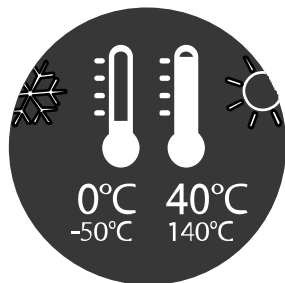

NOTAS LEGALES

Este aparato contiene baterías que no pueden ser reemplazadas. Por el presente, DECATHLON declara que el aparato Oncoach900 y el Oncoach900HR cumplen los requisitos esenciales y otras disposiciones pertinentes de la Directiva 2014/53/UE. La declaración de conformidad CE está disponible en el siguiente enlace web: ONCOACH 900 : https://support.decathlon.fr/oncoach900_doc / ONCOACH 900HR : https://support.decathlon.fr/oncoach900hr_doc

CONECTAR

Apreciamos sus comentarios sobre la calidad, funcionalidad o uso de nuestros productos: supportdecathlon.com. Le contestaremos lo antes posible.

DE

INHALT

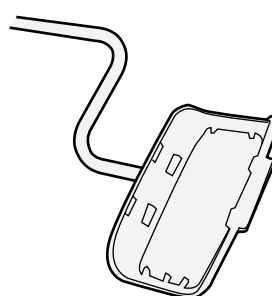
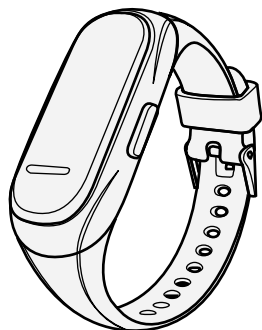
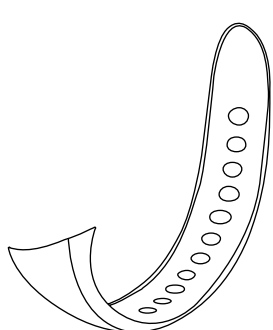

Ladestation

ERSTER GEBRAUCH

• INTUITIVE HILFE

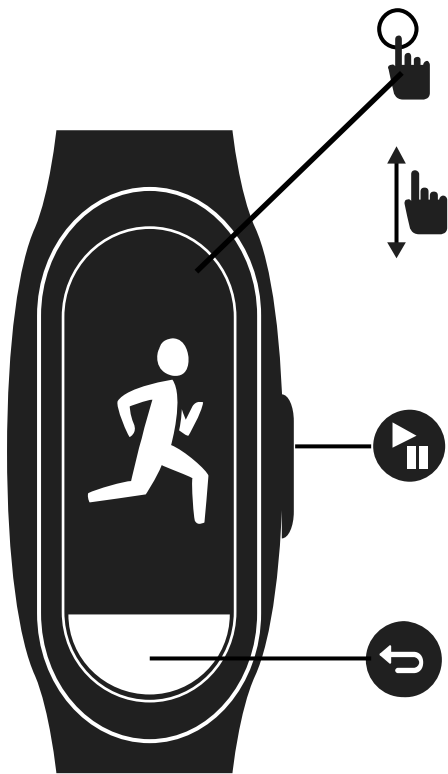

Touchscreen berühren:

Menü wählen / Wert einstellen

Über Touchscreen Wischen:

Seite wechseln

Wiedergabe/Unterbrechung

Jederzeit: Bestätigen
Aktiv: Unterbrechen

Zurück:

Jederzeit: Zurück

Aktiv: Unterbrechen /
Trainingseinheit anhalten

DE

• ONCOACH900/900 HR AUFLADEN

Wir empfehlen Ihnen, das Produkt vor dem ersten Gebrauch vollständig aufzuladen:

- Klipsen Sie das Ladegerät an Ihre Oncoach900/900 HR-Uhr
- Schließen Sie die Uhr an den USB-Port eines Computers oder an einen USB-Adapter 5V - 1A an, um sie vollständig aufzuladen

• ERSTE EINSTELLUNGEN

Drücken Sie 3 Sekunden lang die Schaltfläche . Wählen Sie zwischen einer manuellen Einstellung (MANUELL) oder einer Einstellung per Smartphone (VERBINDEN). Wenn Sie den manuellen Modus wählen, können Sie ihre Uhr immer noch zu einem späteren Zeitpunkt über das Hauptmenü anschließen ► **EINSTELLUNGEN** ► **Verbinden**

23

• MANUELLE EINSTELLUNGEN

Stellen Sie die Parameter ein (Sprache, Datum, Geschlecht, Größe, Gewicht, Alter) und inkrementieren/dekrementieren Sie die Werte durch Berühren der taktilen Bereiche auf dem Touchscreen ⊕/⊖. Bestätigen Sie die Einstellungen durch Drücken von 

DE

• EINSTELLUNGEN PER SMARTPHONE

Laden und starten Sie die Applikation DECATHLON CONNECT über Google Play (Android) oder im App Store (iOS) oder über supportdecathlon.com Erstellen Sie ein Konto oder stellen Sie eine Verbindung zu der Applikation her. Folgen Sie den Anweisungen auf Ihrem Telefon, um Ihre ONcoach900/900 HR-Uhr mit der Applikation zu verbinden. Sobald die Verbindung hergestellt ist, wird die ONcoach900/900 HR-Uhr automatisch eingestellt. Achten Sie darauf, dass die Bluetooth-Funktion auf Ihrem Telefon beim Herstellen der Verbindung aktiviert ist.

HERZFREQUENZ AM HANDGELENK MESSEN (nur Oncoach900HR)

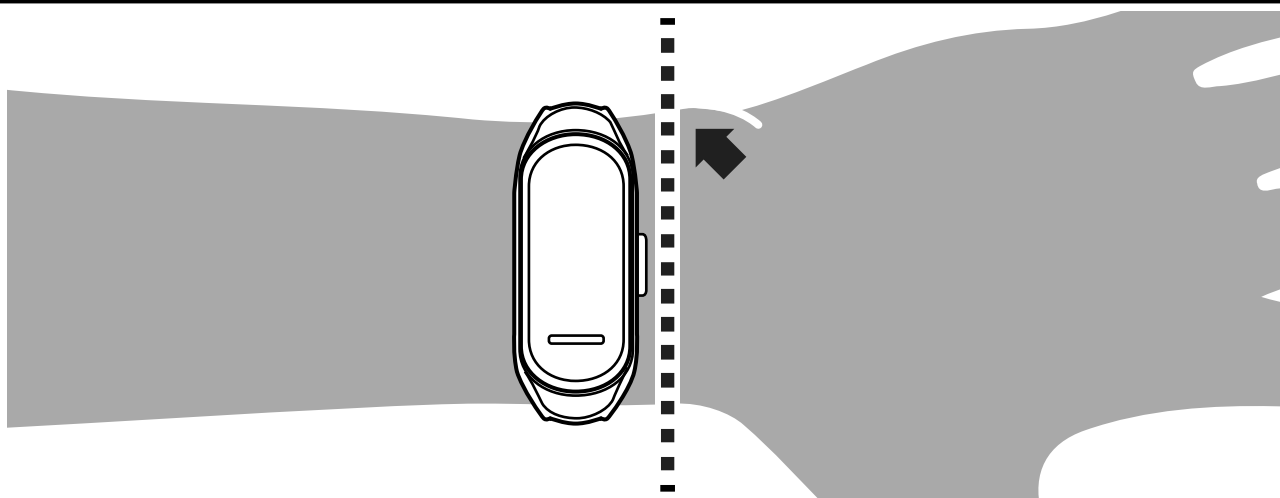

Um eine genaue Messung Ihrer Herzfrequenz zu gewährleisten,:







- müssen Sie die Uhr mit dem Display nach oben zeigend auf Ihrem Handgelenk tragen.
- Die Uhr muss oberhalb des Knochens positioniert werden und auf der Haut aufliegen.
- Stellen Sie das Armband so ein, dass es fest sitzt, sich aber bequem anfühlt.
- Die Uhr sollte sich weder drehen noch verrutschen.



Hinweis: Das Messen der Herzfrequenz mit einem Herzfrequenzmesser (optischer Sensor) am Handgelenk eignet sich optimal für eine sportliche

Betätigung mit repetitiven Bewegungsabläufen, wie z. B. das Laufen oder Walken. Bei einem Fitness-Sport (Muskelaufbautraining) empfiehlt sich die Verwendung eines Brustgurts zum Messen der Herzfrequenz

AKTIVITÄT STARTEN UND VERFOLGEN

• AKTIVITÄT STARTEN

- Drücken Sie auf , um das Hauptmenü zu öffnen
- Gehen Sie zum Modus AKTIVITÄT Durch Wischen über den Touchscreen 
- Wählen Sie den Modus AKTIVITÄT durch Drücken von 
- Wählen Sie Ihre Sportart durch Wischen über den Touchscreen 
- Wählen Sie Ihre Sportart durch Drücken auf 
- Drücken Sie auf , um die Aktivität zu starten

Wenn Sie einen Laufsport wählen, schlägt Ihnen die ONcoach900/900HR-Uhr ein Zeitziel vor. Dieses Ziel wird jedes Mal, wenn Sie es erreichen, automatisch um 5 Minuten inkrementiert. Definieren Sie das Ziel durch Antippen der Schaltflächen / auf dem Touchscreen und validieren Sie mit 

• **ANZEIGE WÄHREND EINER AKTIVITÄT WECHSELN** : Wischen Sie über den Touchscreen 

• **UNTERBRECHEN** : Drücken Sie auf 

• **AKTIVITÄT ANHALTEN** :

Drücken Sie während der Unterbrechung auf . Bestätigen Sie die Unterbrechung der Trainingseinheit durch Antippen des Touchscreens. Wenn Sie die Trainingseinheit speichern möchten, wählen Sie die entsprechende Option auf dem Touchscreen.

TÄGLICHE AKTIVITÄT MESSEN UND VISUALISIEREN

ONcoach900/900HR-Uhren gewährleisten das ununterbrochene und automatische Messen beim täglichen Gehen und registrieren zusätzlich Ihre Herzfrequenz beim Gehen und beim Ruhen. (nur Oncoach900HR) Sie können diese Informationen für den aktuellen Tag anzeigen; wählen Sie dazu das Menü MEIN TAG über das Hauptmenü.

DATUMN AUF IHR SMARTPHONE ÜBERTRAGEN



Die Datumn Ihrer ONcoach900/900HR-Uhr werden automatisch beim Öffnen der Applikation DECATHLON CONNECT übertragen. Dazu müssen Sie sich vergewissern, dass:

DE





- Bluetooth auf Ihrem Telefon aktiviert ist
- Die ONcoach900/900HR-Uhr bereits mit der Applikation verbunden ist

EINSTELLUNGEN

So greifen Sie auf die Einstellungen zu:

- Drücken Sie auf , um das Hauptmenü zu öffnen
- Gehen Sie zum Modus EINSTELLUNGEN Durch Wischen über den Touchscreen 
- Wählen Sie den Modus EINSTELLUNGEN durch Drücken auf 

• ALARM



- Berühren Sie den Touchscreen Alarm um den Alarm zu aktivieren
- Stellen Sie die Stunden für den Alarm durch Antippen der Schaltflächen  ein und bestätigen Sie mit 
- Validieren Sie die Minuten für den Alarm mit 
- Zum Deaktivieren des Alarms tippen Sie auf den Touchscreen Alarm durch Antippen der Schaltflächen  ein
- Stellen Sie die Minuten für den Alarm

• RUHEMODUS

Wenn der Ruhemodus deaktiviert ist, tippen Sie auf den Touchscreen , um ihn zu aktivieren.

Wenn der Ruhemodus aktiviert ist, tippen Sie auf den Touchscreen , um ihn zu deaktivieren.

• Uhrzeit

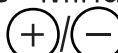

- Über das Menü EINSTELLUNGEN, tippen Sie auf , um das Menü Uhrzeit zu öffnen.
- Stellen Sie die Stunden mit den Schaltflächen  auf dem Touchscreen ein und validieren Sie mit 
- Stellen Sie die Minuten mit den Schaltflächen  auf dem Touchscreen ein und validieren Sie

mit 

- Stellen Sie das Format durch



• DATUM

- Über das Menü EINSTELLUNGEN , wischen Sie über den Touchscreen, um das Menü Datum zu öffnen . Tippen Sie auf  , um das Menü Datum zu öffnen

- Stellen Sie das Jahr mit den Schaltflächen / auf dem Touchscreen ein und validieren Sie

• BENUTZER

- Über das Menü EINSTELLUNGEN , wischen Sie über den Touchscreen, um das Menü Benutzer zu öffnen. Tippen Sie auf  , um das Menü Benutzer zu öffnen.

- Stellen Sie die Größe mit den Schaltflächen / auf dem Touchscreen ein und validieren Sie mit 

- Stellen Sie das Gewicht mit den

• Verbinden



- Der Modus Verbinden ermöglicht das Anschließen Ihres Produkts an ein Smartphone.

- Laden und starten Sie die Applikation DECATHLON CONNECT über Google Play (Android) oder im App Store (iOS) oder über supportdecathlon.com



- Erstellen Sie ein Konto oder stellen Sie eine Verbindung zu der Applikation her

Antippen des Touchscreens ein und validieren Sie mit 



mit 

- Stellen Sie den Monat mit den Schaltflächen / auf dem Touchscreen ein und validieren Sie mit 

- Stellen Sie das Format durch Antippen des Touchscreens ein und validieren Sie mit 

Schaltflächen / auf dem Touchscreen ein und validieren Sie mit 

- Stellen Sie das Format durch Antippen des Touchscreens ein und validieren Sie mit 

- Stellen Sie das Gewicht mit den Schaltflächen / auf dem Touchscreen ein und validieren Sie mit 

- Folgen Sie den Anweisungen auf Ihrem Telefon, um Ihre ONcoach900/900 HR-Uhr mit der Applikation zu verbinden.

- Sobald die Verbindung hergestellt ist, wird die ONcoach900/900 HR-Uhr automatisch eingestellt.

- Achten Sie darauf, dass die Bluetooth-Funktion auf Ihrem Telefon beim Herstellen der Verbindung aktiviert ist.

ÄNDERE DAS ARMBAND

DE

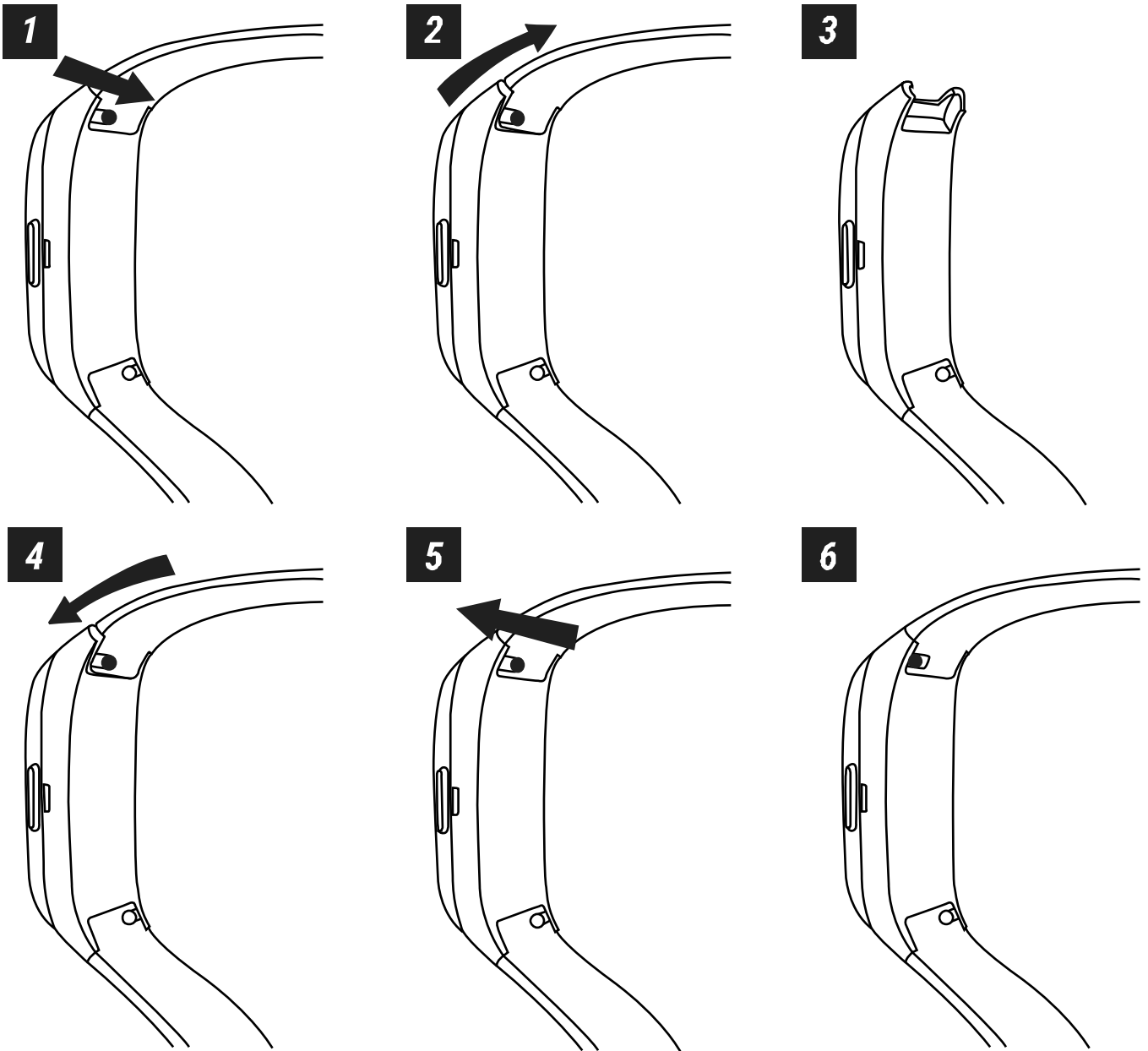

TECHNISCHE EIGENSCHAFTEN

Gewicht: 24 g / 0,052 lb / 0,84 oz

Batterie: Wiederaufladbarer Lithium-Ionen-Akku

Wasserdichtheit: 5 ATM, schwimmbeständig

Autonomie: ONCOACH 900 : 12 Tage

ONCOACH 900HR : 4 Tage

Ladezeit: ONCOACH900/900HR : 2,5 Std

Armband: Reparabel, im Geschäft erhältlich

VORSICHTSMASSNAHMEN

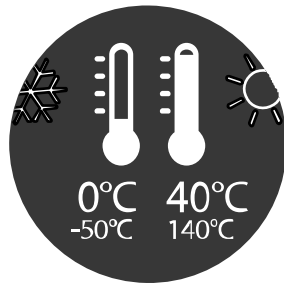

IT

Impressum

Dieses Gerät enthält nicht austauschbare Batterien. Hiermit erklärt DECATHLON, dass die Geräte Oncoach900 und Oncoach900HR die wesentlichen Anforderungen und alle sonstigen einschlägigen Bestimmungen der Richtlinie 2014/53/EU erfüllen. Die EG-Konformitätserklärung ist unter folgendem Link erhältlich: ONCOACH 900 : https://support.decathlon.fr/oncoach900_doc / ONCOACH 900HR : https://support.decathlon.fr/oncoach900hr_doc

VERBINDEN

Gerne können Sie uns Ihre Kommentare und Anmerkungen in Bezug auf die Qualität, die Funktionalität oder die Verwendung unserer Produkte mitteilen: supportdecathlon.com. Wir bemühen uns, Ihnen so schnell wie möglich zu antworten.

IT

CONTENUTO

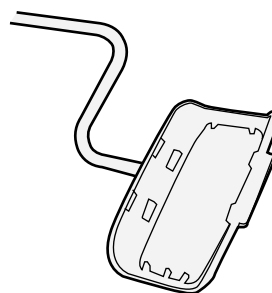
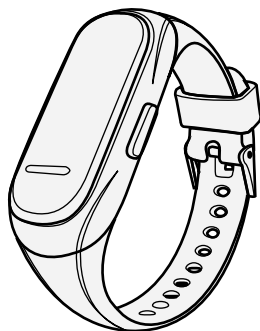
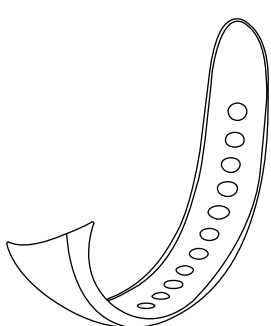

Base di ricarica

PRIMO UTILIZZO

• AIUTO INTUITIVO

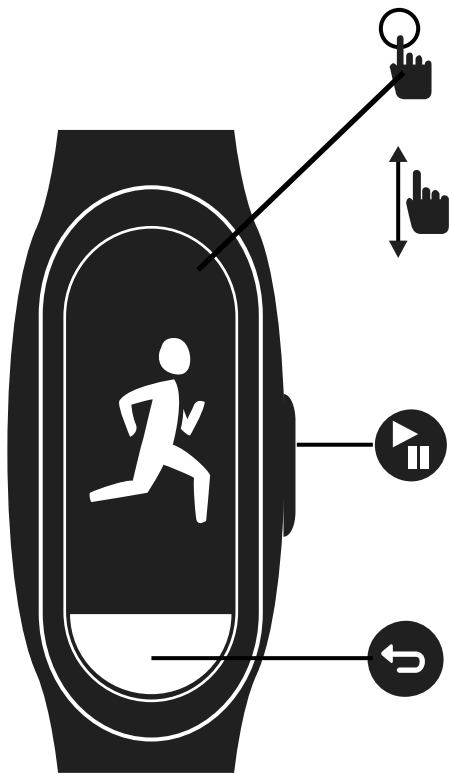

Pressione su touchscreen: Selezionare un menu / impostare un valore

Scorrimento touchscreen: Cambiamento pagina

Play/pausa In qualsiasi momento: conferma

In attività: messa in pausa

Indietro: In qualsiasi momento: indietro

In attività: messa in pausa / arresto sessione

• RICARICA DELL'ONCOACH900/900 HR

Consigliamo di ricaricare completamente il prodotto prima del primo utilizzo:

- Connettere il caricabatteria all'ONcoach900/900 HR connettendolo alla porta USB del computer o a un adattatore USB
- Ricaricare completamente l'orologio 5V - 1A

• PRIME REGOLAZIONI

Premere il pulsante  per 3 secondi. Scegliere tra le regolazioni manuale (MANUALE) o via smartphone (CONNESSIONE). Selezionando la modalità manuale, si potrà sempre connettere l'orologio in seguito dal menu principale ►

REGOLAZIONI ► Connessione

• REGOLAZIONI MANUALI

I parametri di lingua, data, genere, statura, peso, età si impostano premendo il touchscreen nelle zone (+)/(-). Confermare le impostazioni premendo il pulsante



• REGOLAZIONI VIA SMARTPHONE

Scaricare e aprire l'applicazione DECATHLON CONNECT in Google Play (Android) o App Store (iOS) o in supportdecathlon.com. Creare un account o connettersi all'applicazione. Per connettere l'ONcoach900/900 HR all'applicazione. Una volta connesso, l'ONcoach900/900 HR si imposta automaticamente. Per effettuare la connessione, ricordarsi di attivare il bluetooth del telefono.

IT

MISURA DELLA FREQUENZA CARDIACA AL POLSO (solo ONcoach900HR)

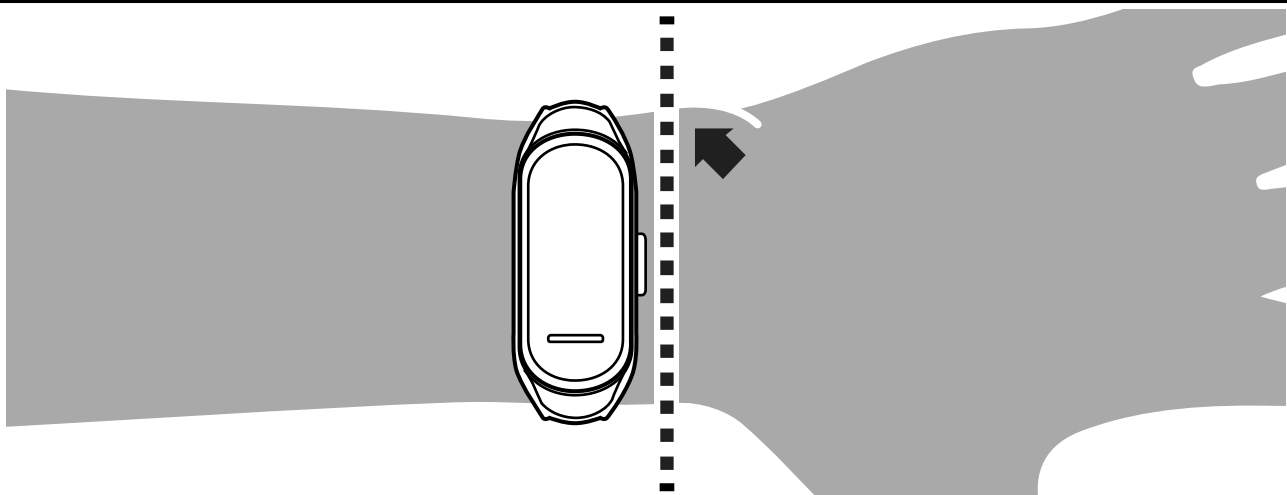







Per garantire una misurazione precisa del ritmo cardiaco:



- Tenere l'orologio con il quadrante sopra la parte superiore del polso.
- L'orologio deve essere posto dietro l'osso, a contatto con la pelle.
- Regolare il cinturino in modo che sia stretto senza infastidire.
- L'orologio non deve ruotare o spostarsi sul polso.

Nota: la misura della frequenza cardiaca con un sensore cardiografico al polso (sensore ottico) è ottimale durante le pratiche sportive con movimenti ripetitivi, come la corsa o la marcia. Si consiglia l'uso di un cardiografico toracico per gli sport di fitness (rafforzamento dei muscoli)

AVVIARE E SEGUIRE UN'ATTIVITÀ

• AVVIARE UN'ATTIVITÀ

- Premere  per aprire il menu principale
- Accedere alla modalità ATTIVITÀ facendo scorrere lo schermo 
- Selezionare la modalità ATTIVITÀ premendo 
- Trovare lo sport che si intende praticare facendo scorrere la schermata 
- Selezionare lo sport che si intende praticare premendo 
- Per iniziare l'attività, premere 

Nelle attività di corsa, ONcoach900/900HR propone di porsi un obiettivo di tempo. Tale obiettivo aumenta automaticamente di 5 minuti ogni volta che viene raggiunto. Impostare l'obiettivo toccando i pulsanti / sullo schermo e confermare con 

• **CAMBIAMENTO DI SCHERMATA DURANTE UN'ATTIVITÀ** : Fare scorrere la schermata 

• **METTERE IN PAUSA** : Premere 

• **ARRESTARE L'ATTIVITÀ** :

Dopo la pausa, premere . Confermare l'arresto della sessione premendo lo schermo. Scegliere se salvare la sessione selezionando l'opzione a schermo.

MISURARE E VISUALIZZARE L'ATTIVITÀ QUOTIDIANA

Gli ONcoach900/900HR misurano costantemente e automaticamente l'attività quotidiana di marcia, la frequenza cardiaca e la frequenza cardiaca a riposo. (solo ONcoach900HR) Queste informazioni sono visualizzabili per la giornata in corso selezionando il menu MIO GIORNO dal menu principale.

TRASFERIRE I DATI ALLO SMARTPHONE

Il trasferimento dei dati dell'ONcoach900/900HR avviene automaticamente all'apertura dell'applicazione DECATHLON CONNECT. A questo scopo, assicurarsi che:

- il bluetooth sia attivato sul telefono
- l'ONcoach900/900HR sia già connesso all'applicazione

REGOLAZIONI



Per accedere alle regolazioni:



- Premere  per aprire il menu principale
- Accedere alla modalità REGOLAZIONI facendo scorrere la

schermata 

- Selezionare la modalità REGOLAZIONI premendo 

• ALLARME

- Toccare lo schermo Allarme per attivare l'allarme
- Impostare l'ora dell'allarme toccando i pulsanti / sullo schermo e confermare con 
- Impostare i minuti dell'allarme

toccando i pulsanti / sullo schermo





- Confermare i minuti dell'allarme con 
- Per disattivare l'allarme, toccare la schermata Allarme





• MODALITÀ SILENZIOSA

Quando è disattivata, toccare la schermata  per attivare la modalità silenziosa.

Quando è attivata, toccare la schermata  per disattivare la modalità silenziosa.





• Ora

- Dal menu REGOLAZIONI, premere  per aprire il menu Ora.
- Impostare l'ora toccando i pulsanti / sulla schermata e confermare con 

- Impostare i minuti toccando i pulsanti / sulla schermata e confermare con 
- Impostare il formato toccando la schermata e confermare con 

• DATA

- Dal menu REGOLAZIONI, fare scorrere la schermata per andare nel menu Data. Premere  per aprire il menu Data
- Impostare l'anno toccando i pulsanti / sulla schermata e confermare con 



- Impostare il mese toccando i pulsanti / sulla schermata e confermare con 
- Impostare il formato toccando la schermata e confermare con 





• UTILIZZATORE

- Dal menu **REGOLAZIONI** , fare scorrere la schermata per andare nel menu **Utilizzatore**. Premere  per aprire il menu **Utilizzatore**.
- Impostare la statura toccando i pulsanti / sulla schermata e confermare con .
- Impostare il peso toccando i

• Connessione

- La modalità **Connessione** permette di connettere il prodotto a uno smartphone.
- Scaricare e lanciare l'applicazione **DECATHLON CONNECT** in **Google Play** (Android) o **App Store** (iOS) o in supportdecathlon.com
- Creare un account o connettersi all'applicazione
- Seguire le istruzioni sul telefono per connettere l'**ONcoach900/900HR** alla applicazione.
- Una volta connesso, l'**ONcoach900/900HR** si imposta automaticamente.
- Per effettuare la connessione, ricordarsi di attivare il **bluetooth** del telefono.

pulsanti / sulla schermata e confermare con .

- Impostare il genere toccando la schermata e confermare con .
- Impostare la lingua toccando i pulsanti / sulla schermata e confermare con .

CAMBIA IL BRACCIALETTO

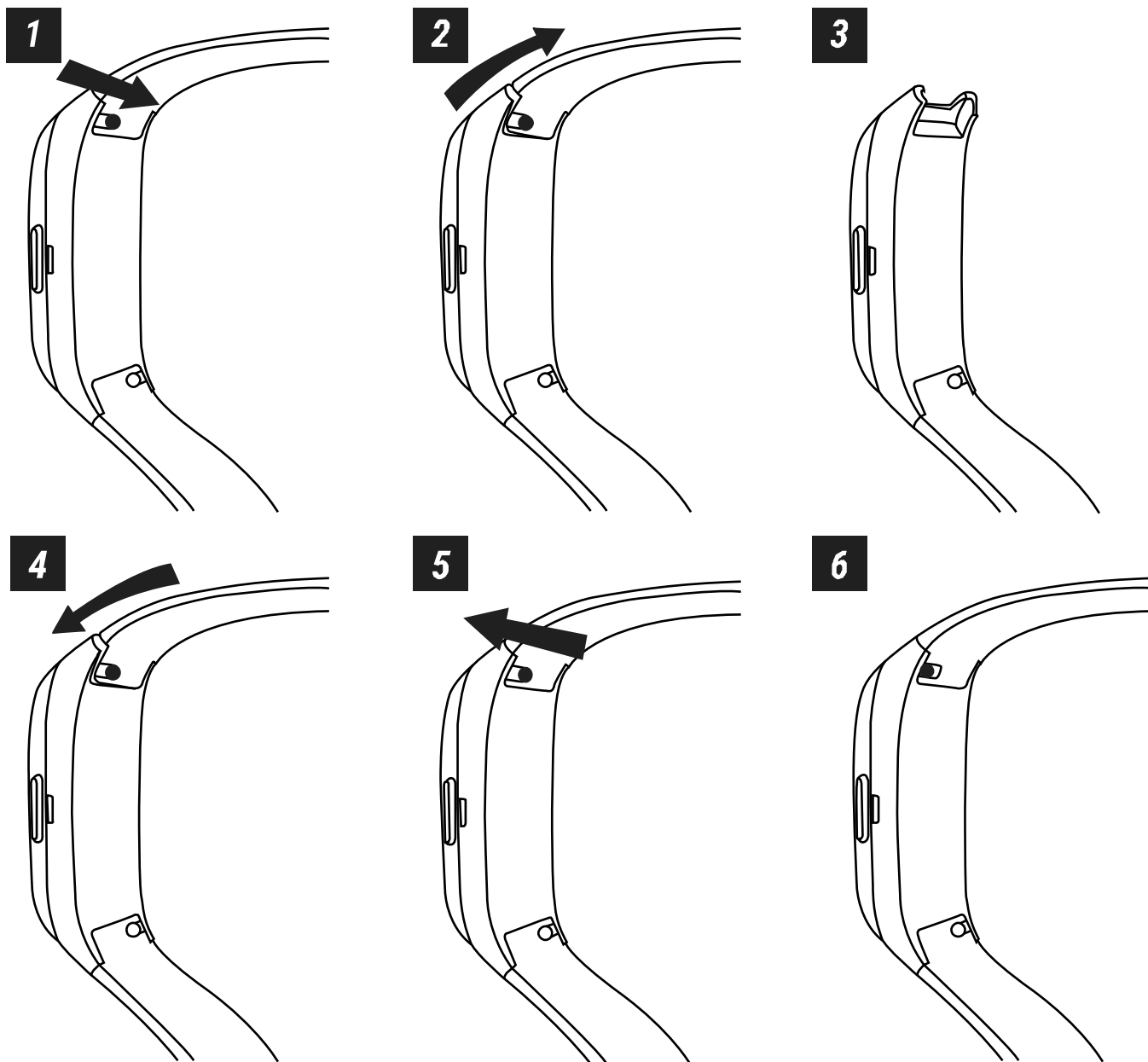

IT

CARATTERISTICHE TECNICHE

Peso: 24 g / 0,052 lb / 0,84 oz

Batteria: Ricaricabile agli ioni di litio

Impermeabilità: 5 ATM, resistente al nuoto

Autonomia: ONCOACH 900 : 12 giorni

ONCOACH 900HR : 4 giorni

Tempo di ricarica: ONCOACH900/900HR : 2h30

Bracciale: riparabile, disponibile in negozio

PRECAUZIONI PER L'USO

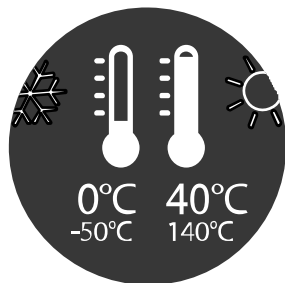

NL

NOTE LEGALI

Questo apparecchio contiene batterie non sostituibili. Con la presente DECATHLON dichiara che l'apparecchio Oncoach900 e Oncoach900HR è conforme ai requisiti essenziali e alle altre disposizioni pertinenti della direttiva 2014/53/EU. La dichiarazione di conformità CE è disponibile al seguente link Internet: ONCOACH 900 : https://support.decathlon.fr/oncoach900_doc / ONCOACH 900HR : https://support.decathlon.fr/oncoach900hr_doc

CONNESSIONE

Siamo a disposizione dei vostri feedback informativi riguardanti la qualità, la funzionalità e l'uso dei nostri prodotti: supportdecathlon.com. Ci impegniamo a rispondervi al più presto.

NL

INHOUD

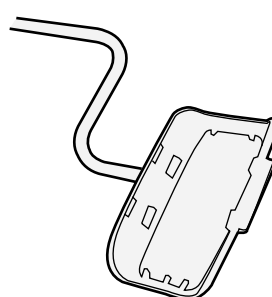
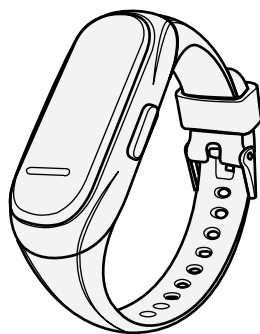
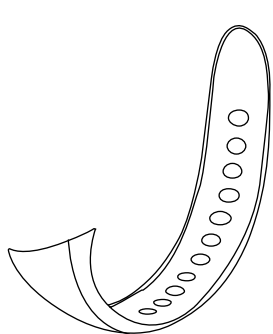

Oplaadbasis

EERSTE INGEBRUIKNEMING

• INTUÏTIEVE HELP

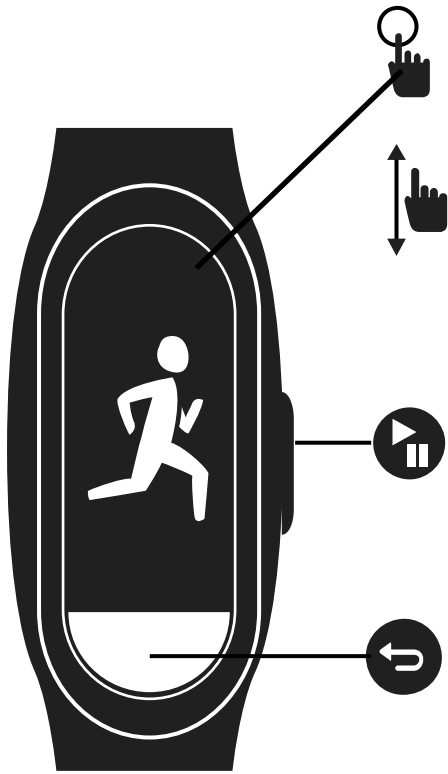

Toets scherm aan-
tikken: Een menu kiezen / een
waarde en stellen

Het toets scherm
scannen: Van pagina veranderen

Play/pause Op elk moment: beves-
tigen

In ACTIVITEITit: op
pauze zetten

Terug: Op elk moment: terug

In ACTIVITEITit: op
pauze zetten / de sessie
beëindigen

• UW ONCOACH900/900 HR LADEN

Voordat u het apparaat voor het eerst in gebruik neemt, raden wij u aan het volledig te laden:

- Klem uw lader vast op de Oncoach900/900 HR
 - Uw horloge volledig geladen door
- het aan te sluiten op een USB-poort van uw computer of op een USB 5V - 1A adapter

• DE EERSTE INSTELLINGEN

De knop  3 seconden indrukken. Maak een keuze tussen de handmatige instellingen (HANDMATIG) of de smartphone (INLOGGEN). Als u de handbediening kiest, kunt u uw horloge altijd later verbinden met het hoofdmenu ► **INSTELLINGEN** ► **Inloggen**

• HANDMATIGE INSTELLINGEN

Stel de taal, datum, geslacht, lichaamslengte, gewicht, leeftijd in door de waarden te verhogen/verlagen door het toets scherm aan te tikken op de desbetreffende gebieden ⊕/⊖. Bevestig de instellingen door het indrukken van de knop 

• INSTELLEN MET DE SMARTPHONE

De applicatie DECATHLON CONNECT downloaden en opstarten van Google Play (Android) of App Store (iOS) of op supportdecathlon.com Een account aanmaken of inloggen op de applicatie Volg de instructies van uw telefoon om uw ONcoach900/900 HR te koppelen met uw applicatie. Na het koppelen, zal uw ONcoach900/900 HR automatisch worden geregeld. Let op dat de Bluetooth is geactiveerd op uw telefoon om het koppelen mogelijk te maken.

METEN VAN DE HARTSLAG OP DE POLS (alleen Oncoach900HR)

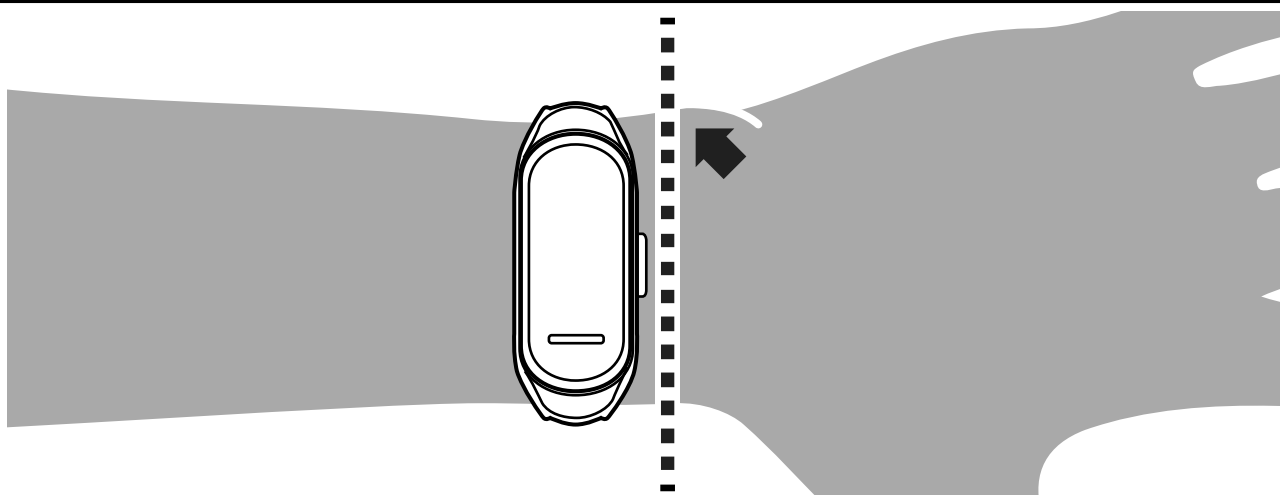

Om nauwkeurige metingen te garanderen van uw hartslag:

- Draag het horloge met de wijzer aan de bovenkant van uw pols.
- Het horloge moet na het bot van de pols worden geplaatst en in aanraking zijn met uw huid.
- Regel het bandje zodanig dat het strak zit maar zonder hinderlijk te zijn.
- Het horloge mag niet om uw pols draaien of bewegen.



Opmerking: het meten van de hartslag met een hartslagmeter om de pols (optische sensor) is optimaal tijdens het beoefenen van een sport met steeds terugkerende bewegingen zoals hardlopen of wandelen. Het wordt aanbevolen om gebruik te maken van een hartslagmeterband voor fitness (spiertraining)

STARTEN EN EEN ACTIVITEIT UITVOEREN

• EEN ACTIVITEIT STARTEN

- Druk op  om het hoofdmenu te openen
- Activeer de functie ACTIVITEIT door het scherm te scannen 
- Kies de functie ACTIVITEIT door  in te drukken
- Kies de sport die u wilt beoefenen door het toets scherm te scannen 
- Kies de sport die u wilt beoefenen door  in te drukken
- Druk op  om de ACTIVITEIT te starten

NL

Indien u wilt hardlopen, zal de ONcoach900/900HR een streeftijd voorstellen. Deze streeftijd zal automatisch 5 minuten worden verlengd wanneer u deze hebt bereikt. Stel de streeftijd een met behulp van de toetsen / op het scherm en bevestig met 

• **HET SCHERM VERANDEREN TIJDENS EEN ACTIVITEIT** : Scan het scherm 

• **OP PAUZE ZETTEN** : Druk op 

• **DE ACTIVITEIT STOPPEN** :

In de pauzefunctie drukt u op . Het beëindigen van de sessie bevestigen door het scherm aan te tikken. Besluit of u de sessie wil bewaren door de overeenkomstige optie op het scherm te kiezen.

UW DAGELIJKSE ACTIVITEIT METEN EN WEERGEVEN

Met de ONcoach900/900HR wordt uw dagelijkse loopACTIVITEIT voortdurend en automatisch gemeten, evenals uw hartslag en uw hartfrequentie wanneer u rust. (alleen Oncoach900HR) U kunt deze informatie weergeven voor de huidige dag door het menu MIJN DAG te kiezen vanuit het hoofdmenu.

UW DATA OVERDRAGEN NAAR UW SMARTPHONE

Het overdragen van data naar uw ONcoach900/900HR gebeurt automatisch bij het openen van de applicatie DECATHLON CONNECT. Hiervoor dient u te controleren of:



- de Bluetooth actief is op uw telefoon gekoppeld met de applicatie
- of uw ONcoach900/900HR al is

INSTELLINGEN

Voor het instellen van de parameters:

- Druk op  om het hoofdmenu te openen
- Activeer de functie **INSTELLINGEN**

• **ALARM**

- Tik op het scherm Alarm om het alarm te activeren
- Stel het tijdstip van het alarm in met behulp van de toetsen / op het scherm en bevestig met 
- Stel de minuten van het alarmtijdstip

• **MUTE-FUNCTIE**

Wanneer deze is uitgeschakeld, tikt u  aan op het scherm om de mute-functie te activeren.

Wanneer deze actief is, tikt u  aan op het scherm om de mute-functie uit te schakelen.

• **Uur**



- Vanaf het menu **INSTELLINGEN**, Drukt u op  om het menu Uur te openen.
- Stel de tijd in met behulp van de toetsen / op het scherm en bevestig met 

• **DATUM**

- Vanaf het menu **INSTELLINGEN**, Het scherm scannen om naar het menu Datum te gaan. Druk op  om het menu Datum te openen
- Stel het jaar in met behulp van de toetsen / op het scherm en bevestig met

door het scherm te scannen 

- Kies de functie **INSTELLINGEN** door  in te drukken

in met behulp van de toetsen / op het scherm

- Bevestig de minuten van het alarm met 
- Om het alarm uit te schakelen, tikt u Alarm aan op het scherm







- Stel de minuten in met behulp van de toetsen / op het scherm en bevestig met 

- Regel het tijdformaat door het scherm aan te tikken en bevestig met 

-  Stel de maand in met behulp van de toetsen / op het scherm en bevestig met 

- Regel het datumformaat door het scherm aan te tikken en bevestig met 

• GEBRUIKER

- Vanaf het menu **INSTELLINGEN**, het scherm scannen om naar het menu **Gebruiker** te gaan. Druk op  om het menu **Gebruiker** te openen.
- Stel de lichaamslengte in met behulp van de toetsen / op het scherm en bevestig met 
- Stel het gewicht in met behulp van de toetsen / op het scherm en bevestig met 
- Stel het geslacht in door het scherm aan te tikken en bevestig met 
- Stel de taal in met behulp van de toetsen / op het scherm en bevestig met 

• Inloggen

- Met de functie **Inloggen** kunt u uw product koppelen aan een smartphone.
- De applicatie **DECATHLON CONNECT** downloaden en opstarten van **Google Play** (Android) of **App Store** (iOS) of op supportdecathlon.com
- Een account aanmaken of inloggen op de applicatie
- Volg de instructies van uw telefoon om uw **ONcoach900/900HR** te koppelen met uw applicatie.
- Na het koppelen, zal uw **ONcoach900/900 HR** automatisch worden geregeld.
- Let op dat de **Bluetooth** is geactiveerd op uw telefoon om het koppelen mogelijk te maken.

VERANDER DE ARMBAND

NL

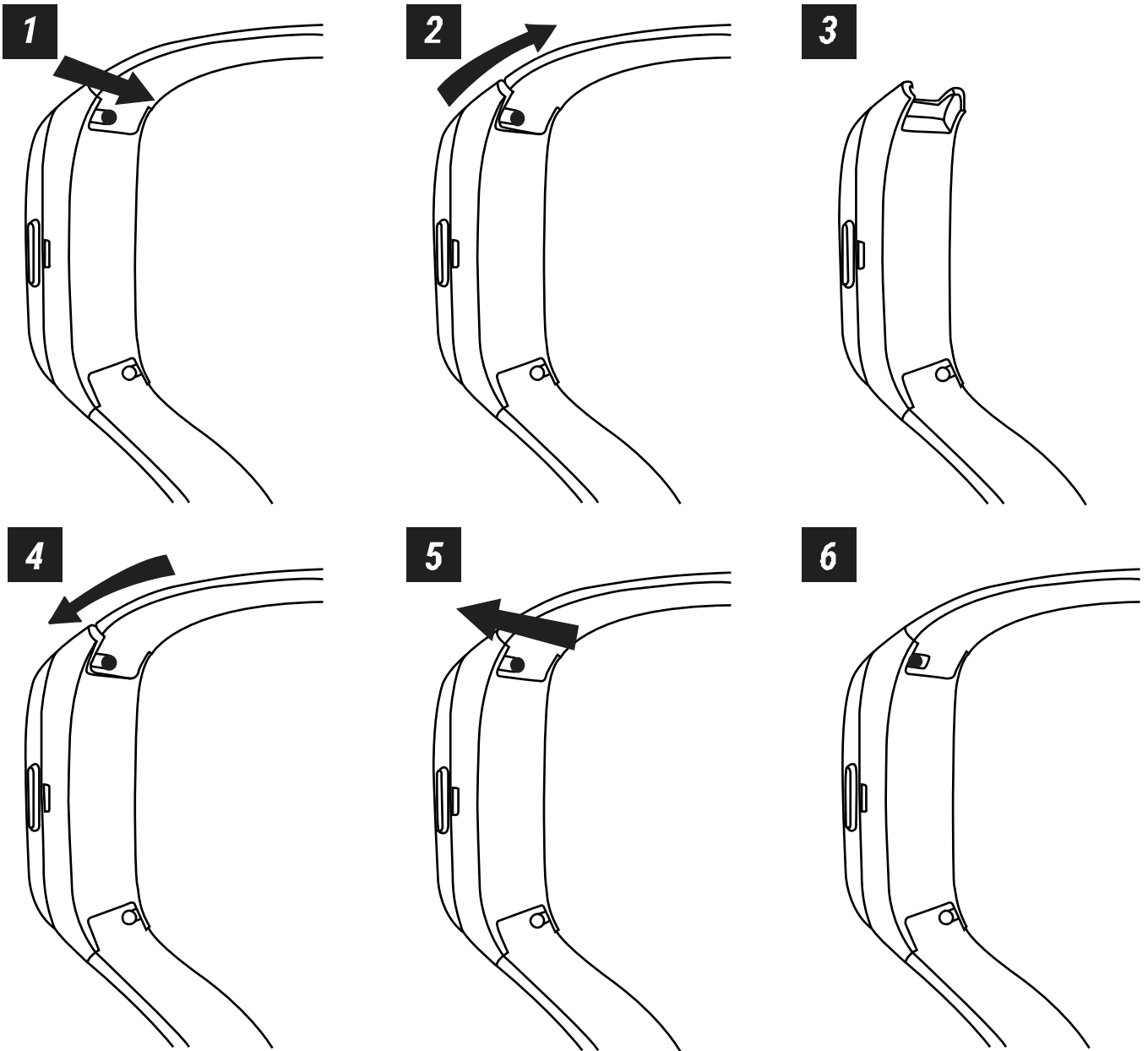

TECHNISCHE GEGEVENS

Gewicht: 24 g / 0,052 lb / 0,84 oz

Accu: Oplaadbare lithium-ion batterij

Dichtheid: 5 ATM, bestand tegen zwemmen

Autonomie: ONCOACH 900 : 12 dagen

ONCOACH 900HR : 4 dagen

Oplaadtijd: ONCOACH900/900HR : 2 uur 30

Armband: repareerbaar, verkrijgbaar in de winkel

VOORZORGSMAATREGELEN BIJ GEBRUIK

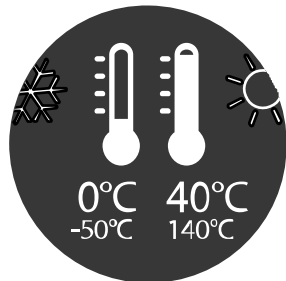

PT

WETTELIJKE VERMELDINGEN

Dit apparaat bevat batterijen die niet kunnen worden vervangen. Hierbij verklaart DECATHLON dat het apparaat Oncoach900 en Oncoach900HR in overeenstemming zijn met de essentiële eisen en de andere relevante bepalingen van richtlijn 2014/53/EG. Een conformiteitsverklaring staat ter beschikking op het internetadres: ONCOACH 900 : https://support.decathlon.fr/oncoach900_doc/ / ONCOACH 900HR : https://support.decathlon.fr/oncoach900hr_doc/

INLOGGEN

Wij staan open voor feedback over kwaliteit, functies of gebruiksbestemmingen van onze producten: supportdecathlon.com. Wij zullen u zo spoedig mogelijk antwoorden.

PT

CONTEÚDO

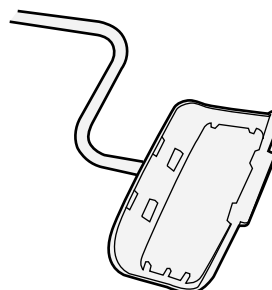
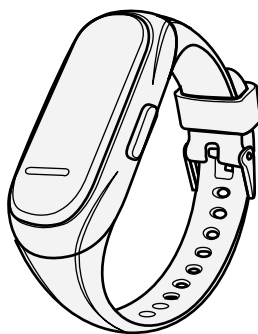
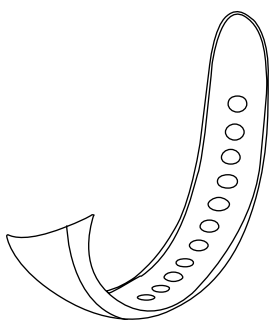

Base de

carregamento

PRIMEIRA UTILIZAÇÃO

• AJUDA INTUITIVA

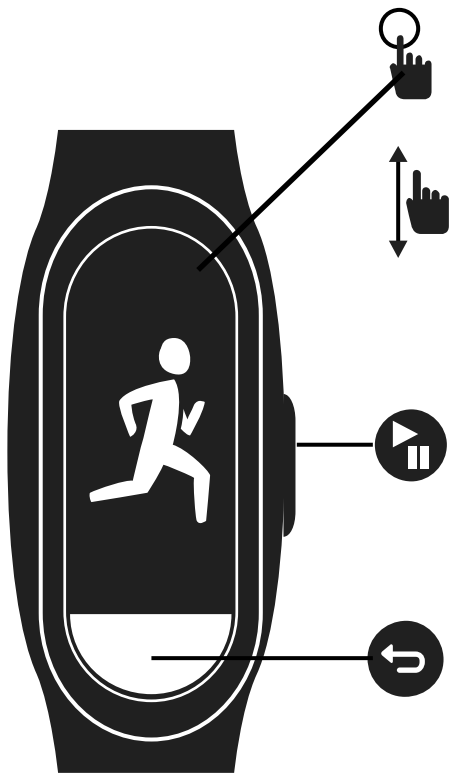

Premir ecrã tátil: Selecionar um menu/ajus-
tar um valor

Deslizar no ecrã tátil: Mudar de página

Reproduzir/pausar A qualquer momento:
confirmar
Em atividade: colocar em
pausa

Retroceder: A qualquer momento:
retroceder
Em atividade: colocar em
pausa/parar a sessão

• CARREGAMENTO DO SEU ONCOACH 900/900HR

Antes da primeira utilização, é recomendável carregar completamente o seu produto:

- Encaixe o carregador no seu Oncoach 900/900HR ligando-o a uma porta USB no seu computador ou a um adaptador USB de 5V -1 A
- Carregue totalmente o relógio

• DEFINIÇÕES INICIAIS

Prima durante 3 segundos o botão . Selecione a forma de definição manual (MANUAL) ou por smartphone (CONNECTAR). Se selecionar o modo manual, será sempre possível ligar o seu relógio posteriormente a partir do menu principal ►DEFINIÇÕES►CONNECTAR

• DEFINIÇÕES MANUAIS

Defina os parâmetros de idioma, data, género, tamanho, peso e idade, aumentando/diminuindo os valores ao premir o ecrã tátil nas zonas (+)/(-). Confirme as definições premindo o botão 

• DEFINIÇÕES POR SMARTPHONE

Descarregue e inicie a aplicação DECATHLON CONNECT a partir da Google Play (Android) ou da App Store (iOS), ou em supportdecathlon.com. Crie uma conta ou ligue-se à aplicação. Siga as instruções no seu telemóvel para ligar o seu ONcoach 900/900HR à aplicação. Após a ligação, o seu ONcoach 900/900HR ajusta-se automaticamente. Não se esqueça de ativar o bluetooth do seu telemóvel para fazer a ligação.

PT

MEDIÇÃO DA FREQUÊNCIA CARDÍACA NO PULSO (apenas no Oncoach 900HR)

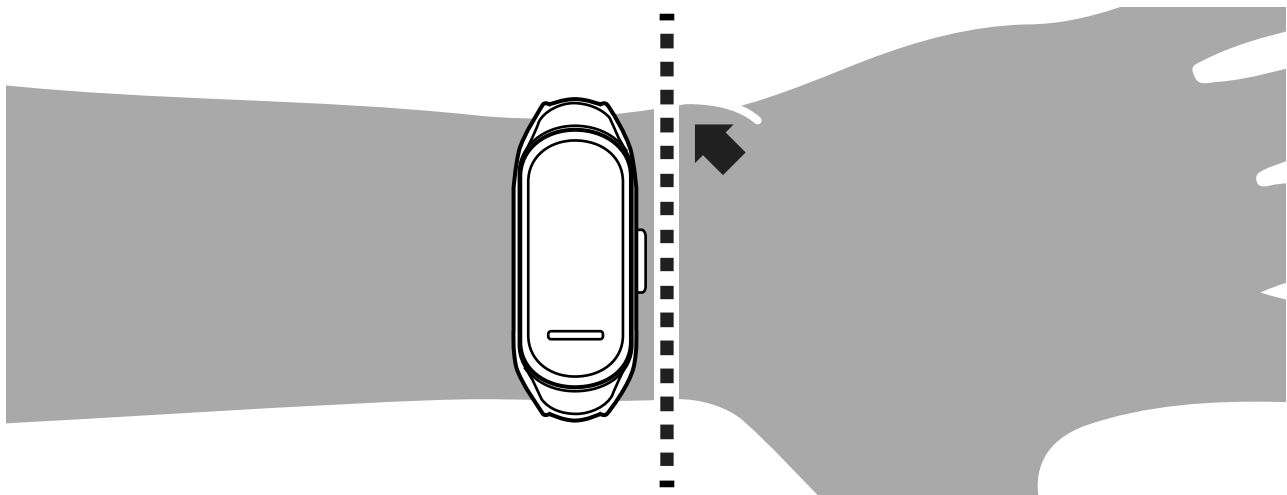







Para garantir uma medição precisa do seu ritmo cardíaco:

- Utilize o relógio com o mostrador na parte superior do pulso.
- O relógio tem de estar posicionado após o osso, em contacto com a sua pele.
- Ajuste a correia para que esta fique justa, mas sem apertar em demasia.
- O relógio não deve rodar nem mover-se livremente no pulso.

Nota: a medição da frequência cardíaca com um cardio-frequencímetro de pulso (sensor ótico) é ideal para a prática de desportos com movimentos repetitivos, como a corrida ou a caminhada. É aconselhável utilizar um cinto cardio-frequencímetro para desportos de fitness (halterofilismo)



INICIAR E CONTINUAR UMA ATIVIDADE

• INICIAR UMA ATIVIDADE

- Prima  para abrir o menu principal
- Aceda ao modo ATIVIDADE deslizando sobre o ecrã 
- Selecione o modo ATIVIDADE premindo 
- Identifique o desporto que pretende praticar, deslizando sobre o ecrã 
- Selecione o desporto que pretende praticar, premindo 
- Prima  para iniciar a atividade

PT

Para uma atividade de corrida, o ONcoach 900/900HR propõe-lhe a criação de um objetivo de tempo. Este objetivo aumenta automaticamente 5 minutos em cada vez que o alcançar. Defina o objetivo premindo os botões (+)/(-) do ecrã e confirme com 

- **MUDAR O ECRÃ DURANTE UMA ATIVIDADE** : Deslize sobre o ecrã 
- **COLOCAR EM PAUSA** : Prima 
- **PARAR A ATIVIDADE** :

Durante a pausa, prima . Confirme a paragem da sessão premindo o ecrã. Escolha se pretende guardar a sessão, selecionando a opção no ecrã.

MEDIR E VISUALIZAR A SUA ATIVIDADE DIÁRIA

Os ONcoach 900/900HR medem de forma contínua e automática a sua atividade diária de caminhada, bem como a sua frequência cardíaca em descanso. (apenas no Oncoach 900HR) Pode visualizar estas informações durante o dia em curso, selecionando o menu MEU DIA a partir do menu principal.

TRANSFERIR OS SEUS DADOS PARA O SEU SMARTPHONE

A transferência dos dados do seu ONcoach 900/900HR é feita automaticamente no início da aplicação DECATHLON CONNECT. Para tal, deve certificar-se de que:



- o bluetooth está ativado no seu telemóvel
- o seu ONcoach 900/900HR já está ligado à aplicação

DEFINIÇÕES

Para aceder às definições:

- Prima  para abrir o menu principal
- Aceda ao modo DEFINIÇÕES

• ALARME





- Toque no ecrã Alarme para ativar o Alarme
- Defina a hora do Alarme premindo os botões / do ecrã e confirme com 
- Defina os minutos do Alarme

• MODO SILENCIOSO



Quando estiver desativado, toque no ecrã  para ativar o modo silencioso.

Quando estiver ativado, toque no ecrã  para desativar o modo silencioso.

• Hora

- A partir do menu DEFINIÇÕES , prima  para abrir o menu Hora.
- Acerte a hora premindo os botões / do ecrã e confirme com 

• DATA

- A partir do menu DEFINIÇÕES , deslize pelo ecrã para aceder ao menu Data . Prima  para abrir o menu Data
- Defina o ano premindo os botões 





deslizando sobre o ecrã 

- Selecione o modo DEFINIÇÕES premindo 





premiendo os botões / do ecrã

- Confirme os minutos do Alarme com 
- Para desativar o Alarme toque no ecrã Alarme











PT

- Acerte os minutos premindo os botões / do ecrã e confirme com 
- Defina o formato tocando no ecrã e confirme com 

/ do ecrã e confirme com 

- Defina o mês premindo os botões / do ecrã e confirme com 
- Defina o formato tocando no ecrã e confirme com 

• UTILIZADOR

- A partir do menu DEFINIÇÕES , deslize pelo ecrã para aceder ao menu Utilizador. Prima  para abrir o menu Utilizador.
- Defina o tamanho premindo os botões / do ecrã e confirme com 
- Defina o peso premindo os botões / do ecrã e confirme com 
- Defina o género tocando no ecrã e confirme com 
- Defina o idioma premindo os botões / do ecrã e confirme com 

PT

• CONECTAR

- O modo CONECTAR permite-lhe ligar o seu produto a um smartphone.
- Descarregue e inicie a aplicação DECATHLON CONNECT a partir da Google Play (Android) ou da App Store (iOS), ou em supportdecathlon.com
- Crie uma conta ou ligue-se à aplicação
- Siga as instruções no seu telemóvel para ligar o seu ONcoach 900/900HR à aplicação.
- Após a ligação, o seu ONcoach 900/900HR ajusta-se automaticamente.
- Não se esqueça de ativar o bluetooth do seu telemóvel para fazer a ligação.

MUDE A PULSEIRA

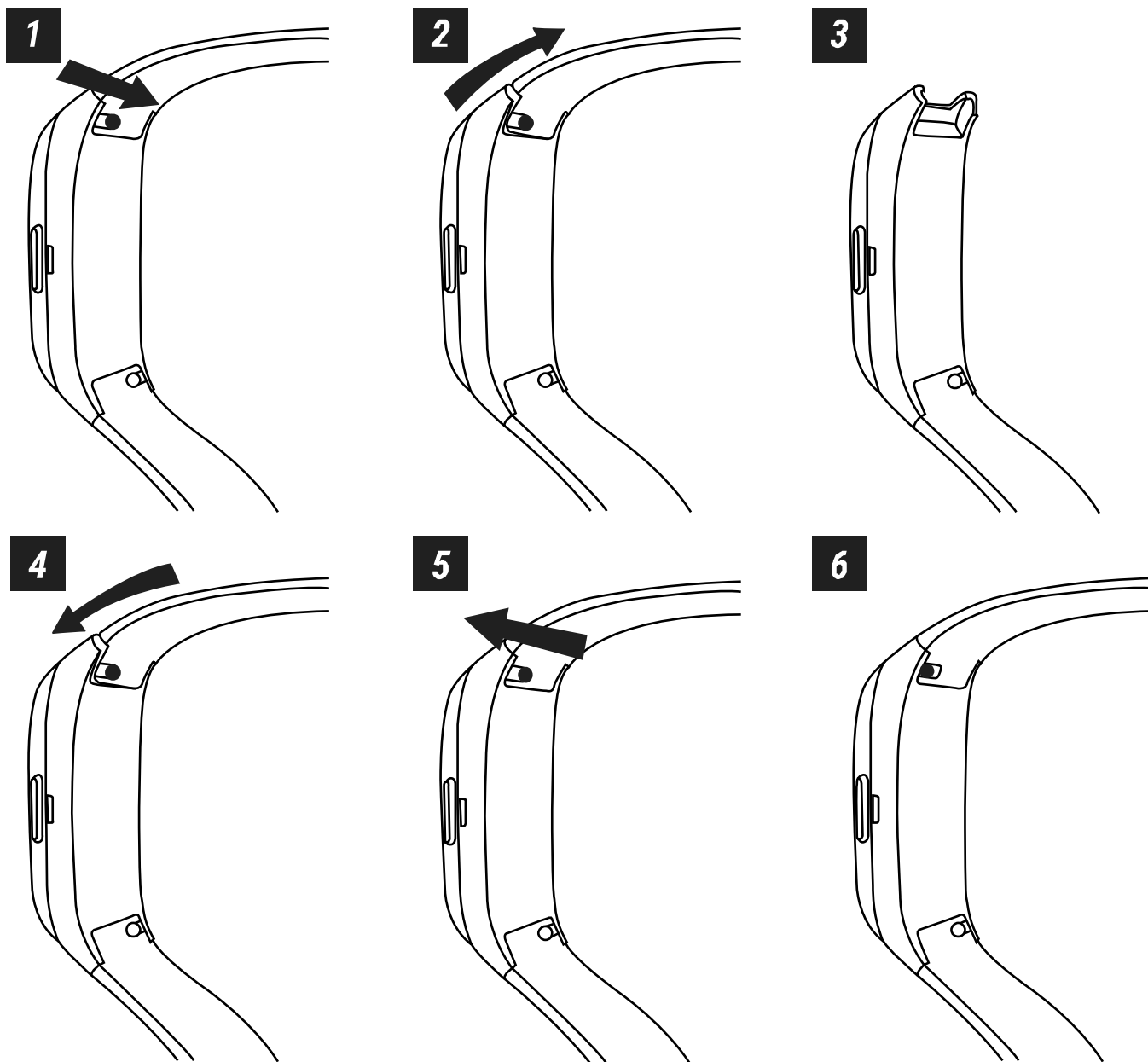

PT

CARACTERÍSTICAS TÉCNICAS

Peso: 24 g/0,052 lb/0,84 oz

Bateria: Recarregável de iões de lítio

Estanquicidade: 5 ATM, resistente ao nado

Autonomia: ONCOACH 900 : 12 dias

ONCOACH 900HR : 4 dias

Tempo de carga: ONCOACH900/900HR : 2h30

Bracelete: reparável, disponível em loja

PRECAUÇÕES DE UTILIZAÇÃO

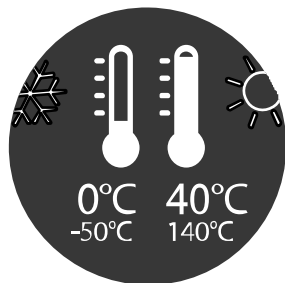

AVISO LEGAL

PL

Este aparelho contém pilhas não substituíveis. A DECATHLON declara que o aparelho Oncoach 900 e Oncoach 900HR cumpre os requisitos essenciais e outras provisões relevantes da norma 2014/53/UE. A declaração de conformidade CE está disponível para consulta na seguinte ligação da Web: ONCOACH 900 : https://support.decathlon.fr/oncoach900_doc / ONCOACH 900HR : https://support.decathlon.fr/oncoach900hr_doc

CONECTAR

Gostaríamos de conhecer a sua opinião sobre a qualidade, a funcionalidade e a utilização dos nossos produtos: supportdecathlon.com. Responderemos ao seu contacto logo que possível.

PL

ZAWARTOŚĆ

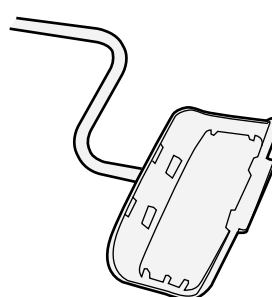
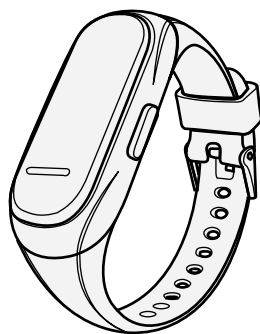
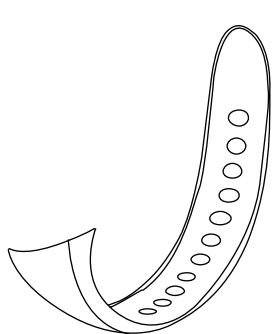

Ładowarka

PIERWSZE UŻYCIE

• INTUICYJNA POMOC

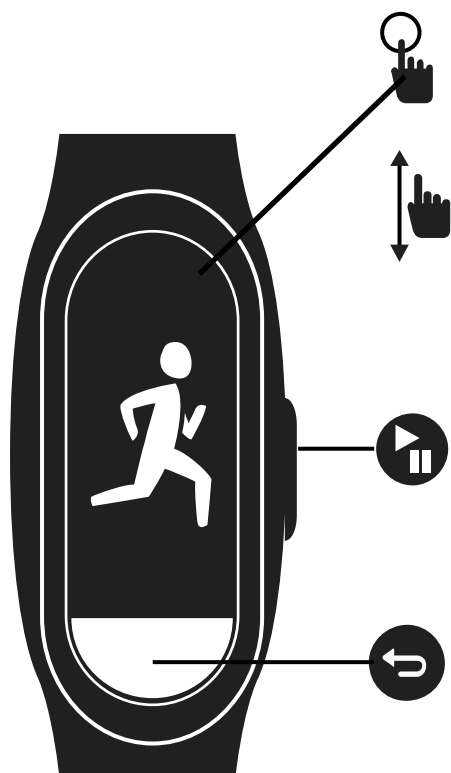

Dotknięcie ekranu dotykowego: wybór menu / ustawienie wartości

Przesuwanie po ekranie dotykowym: zmiana strony

Start/Pauza W dowolnym momencie: zatwierdzenie

W czasie aktywności: pauza

Powrót: W dowolnym momencie: powrót

W czasie aktywności: pauza / zakończenie sesji

PL

• ŁADOWANIE ONCOACH900/900 HR

Przed pierwszym użyciem zalecamy całkowicie naładować produkt:

- Podłączyć ładowarkę do Oncoach900/900 HR
- Naładować zegarek po podłączeniu do portu USB w komputerze lub za pomocą zasilacza USB 5 V-1 A

• PIERWSZE USTAWIENIA

Naciskać przez 3 sekundy przycisk . Wybrać ustawienia ręczne (ręczny) lub ustawienia przez smartfona (Łączenie). Jeżeli wybrano tryb ręczny, w późniejszym czasie zawsze można połączyć się z zegarkiem ze smartfona ►

USTAWIENIA ► Łączenie

• USTAWIENIA RĘCZNE

Ustawić parametry języka, datę, płeć, wzrost, masę ciała, wiek poprzez zwiększanie lub zmniejszanie wartości, naciskając ekran dotykowy w strefach (+) / (-). Zatwierdzić, naciskając przycisk (↵)

• USTAWIENIA PRZEZ SMARTFONA

Pobrać i uruchomić aplikację DECATHLON CONNECT z Google Play (Android) lub App Store (iOS) lub na supportdecathlon.com. Utworzyć konto lub zalogować się w aplikacji. Postępować zgodnie z instrukcjami w telefonie, aby połączyć ONcoach900/900 HR z aplikacją. Po podłączeniu, ustawienia w ONcoach900/900 HR odbywają się automatycznie. Włączyć Bluetooth w telefonie, aby nawiązać połączenie.

PL

POMIAR TĘTNA NA NADGARSTKU (tylko Oncoach900HR)

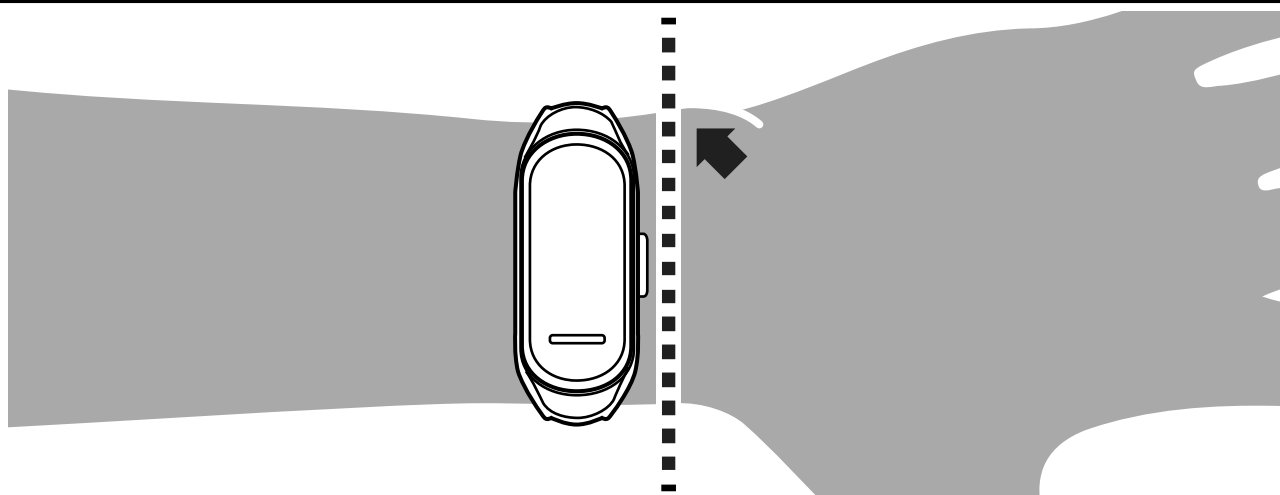







Aby zapewnić dokładność pomiaru pulsu:



- Należy nosić zegarek z tarczą umieszczoną na górnej części nadgarstka.
- Zegarek należy umieścić za kostką i musi stykać się ze skórą.
- Wyregulować bransoletę w taki sposób, aby była zaciśnięta, ale nie powodowała dyskomfortu.
- Zegarek nie może obracać się lub przemieszczać na nadgarstku.

Informacja: pomiar tętna za pomocą czujnika pulsometru na nadgarstku (czujnik optyczny) jest optymalnym rozwiązaniem w przypadku uprawiania sportów, w których wykonuje się powtarzające się ruchy takie, jak bieganie lub jazda na rowerze. Zalecamy używanie paska z pulsometrem w przypadku sportów fitness (siłownia itp)

URUCHOMIENIE I MONITOROWANIE AKTYWNOŚCI

• URUCHOMIENIE AKTYWNOŚCI

- Nacisnąć  , aby otworzyć menu główne
- Wybrać uprawiany sport, przesuważąc palec po ekranie 
- Przejść do trybu CZYNNOŚĆ przesuważąc palec po ekranie 
- Wybrać uprawiany sport, naciskając 
- Wybrać tryb CZYNNOŚĆ naciskając 
- Nacisnąć  , aby rozpocząć uruchomić aktywność

W przypadku biegów, ONcoach900/900HR proponuje ustawienie celu czasowego. Cel zwiększa się automatycznie o 5 minut za każdym razem, gdy zostanie osiągnięty. Ustawić cel, dotykając przycisków / na ekranie i zatwierdzić 

• **ZMIANA EKRANU W TRAKCIE AKTYWNOŚCI** : Przesunąć palcem po ekranie 

• **PAUZA** : Nacisnąć 

• **ZATRZYMANIE AKTYWNOŚCI** :

W trybie pauzy, nacisnąć . Zatwierdzić zatrzymanie sesji, naciskając ekran. Wybrać, aby zapisać sesję poprzez wybranie opcji na ekranie.

POMIAR I WYŚWIETLANIE CODZIENNEJ AKTYWNOŚCI

ONcoach900/900HR mierzy stale i automatycznie codzienną aktywność w postaci liczby kroków i tętno oraz tętno w spoczynku. (tylko Oncoach900HR) Te informacje można wyświetlać dla bieżącego dnia po wybraniu menu MÓJ DZIEŃ w menu głównym.









PRZESYŁANIE DANYCH DO SMARTFONA

Transfer danych ONcoach900/900HR odbywa się automatycznie po uruchomieniu aplikacji DECATHLON CONNECT. W tym celu należy upewnić się, że:

- włączono funkcję Bluetooth w telefonie
- ONcoach900/900HR podłączono do aplikacji

USTAWIENIA

Dostęp do innych ustawień:









- Nacisnąć  , aby otworzyć menu główne
- Przejść do trybu USTAWIENIA
- **ALARM**
- Dotknąć ekranu Alarm aby włączyć alarm
- Ustawić godzinę alarmu, dotykając przycisków / na ekranie i zatwierdzić 
- przesuwając palec po ekranie 
- Wybrać tryb USTAWIENIA naciskając 
- Ustawić minuty alarmu, dotykając przycisków / na ekranie
- Zatwierdzić minuty alarmu 
- Aby wyłączyć alarm, dotknąć ekranu Alarm

PL • TRYB CICHY









Po wyłączeniu, dotknąć ekranu  , aby włączyć tryb cichy.

Po włączeniu, dotknąć ekranu  , aby wyłączyć tryb cichy.







• Czas





- W menu USTAWIENIA nacisnąć  , aby otworzyć menu Godzina.
- Ustawić godzinę, dotykając przycisków / na ekranie i zatwierdzić 
- Ustawić minuty, dotykając przycisków / na ekranie i zatwierdzić 
- Ustawić format, dotykając ekranu i zatwierdzić 

• DATA

- W menu USTAWIENIA przesunąć palcem po ekranie, aby przejść do menu Data Nacisnąć  , aby otworzyć menu Data
- Ustawić rok, dotykając przycisków / na ekranie i zatwierdzić 
- Ustawić miesiąc, dotykając przycisków / na ekranie i zatwierdzić 
- Ustawić format, dotykając ekranu i zatwierdzić 

• UŻYTKOWNIK

- W menu USTAWIENIA przesunąć palcem po ekranie, aby przejść do menu Użytkownik. Nacisnąć  , aby otworzyć menu Użytkownik.
- Ustawić wzrost, dotykając przycisków / na ekranie i zatwierdzić 
- Ustawić masę ciała, dotykając przycisków / na ekranie i zatwierdzić 

- Ustawić płec, dotykając ekranu i zatwierdzić 
- Ustawić język, dotykając przycisków / na ekranie i zatwierdzić 
- **Łączenie**
 - Tryb Łączenie umożliwia podłączenie produktu do smartfona.
 - Pobrać i uruchomić aplikację DECATHLON CONNECT z Google Play (Android) lub App Store (iOS) lub na supportdecathlon.com
 - Utworzyć konto lub zalogować się w aplikacji
 - Postępować zgodnie z instrukcjami w telefonie, aby połączyć ONcoach900/900HR z aplikacją.
 - Po podłączeniu, ustawienia ONcoach900/900 HR odbywają się automatycznie.
 - Włączyć Bluetooth w telefonie, aby nawiązać połączenie.