

DENON

SERVICE MANUAL MODEL DN-600F STEREO CD PLAYER

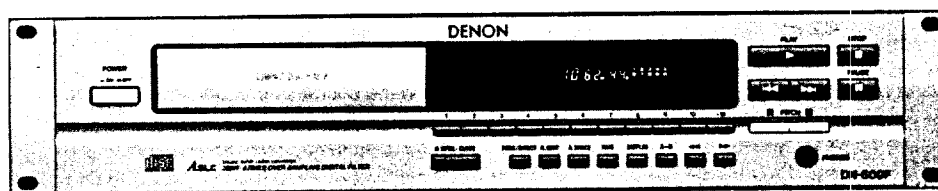

— TABLE OF CONTENTS —

SPECIFICATIONS	2
NOTE FOR HANDLING OF LASER PICK-UP	3, 4
DISASSEMBLY	5
ADJUSTMENT	6 ~ 9
HEAT RUN MODE FUNCTION	10
IC TERMINAL FUNCTION	11 ~ 14
NOTE FOR PARTS LIST	14
PARTS LIST OF P.W.BOARD	15
PACKING & ACCESSORIES	16
PARTS LIST OF PACKING & ACCESSORIES	16
PARTS LIST OF EXPLODED VIEW	16
EXPLODED VIEW	17
PARTS LIST OF FG-70 MECHANISM UNIT	18
EXPLODED VIEW OF FG-70 MECHANISM UNIT	18
P.W.BOARD	19
WIRING DIAGRAM	20
SCHEMATIC DIAGRAM	21
SEMICONDUCTORS	22

NIPPON COLUMBIA CO., LTD.

SPECIFICATIONS

AUDIO

No. of Channels:	2 channels
Frequency Response:	2 - 20,000 Hz
Dynamic Range:	98 dB
Signal-to-noise Ratio:	107 dB
Harmonic Distortion:	0.003 % (1 kHz)
Separation:	103 dB (1 kHz)
Wow & Flutter:	Below measurable limit: (± 0.001 % W.peak)
Output Voltage:	2 V

FUNCTIONS AND DISPLAY

Functions:	Automatic search, programmed playback, repeat playback, manual search, auto space, time mode, auto edit.
Display:	Track number, time, music calendar, emphasis feature and engaged modes.
Others:	Headphones jack

DISCS Compact Disc format

SUPPLIED ACCESSORIES Pin-plug connection cord

GENERAL CHARACTERISTICS

Power Supply:	Voltage is shown on rating label
Power Consumption:	10W
Dimensions:	482 (19") W × 88 (3-15/32") H × 280 (11-1/32") D mm
Weight:	4.2 kg

* Design and specifications are subject to change without notice in the course of product improvement.

NOTE FOR HANDLING OF LASER PICK-UP

Caution for Handling the Laser Pick-up

The laser pick-up KSS-240A is assembled and precisely adjusted using a sophisticated manufacturing process in our plant. Do not disassemble or attempt to readjust it. Please keep the following instructions carefully in handling pick-up.

1. Handle with Care

- (1) Storage
Do not store the pick-up in dusty, high-temperature or high-humidity environments.
- (2) Please take care for preventing from shock by falling down or careless handling.

2. Laser Diode (LD)

- (1) Protect your eyes
The laser beam may damage the human eye, since the intensity of the focused spot may reach $7 \times 10^3 \text{ W/cm}^2$ even if the intensity at the objective lens is 400 μW maximum. As the light beam spreads after focused through the objective lens, it does not effect you in the place as far as more than 30 cms. However, do not look at the laser light beam either through the objective lens directly nor another lens or a mirror.
- (2) Poison of As
Since the LD chip contains As (Arsenic), as GaAs + GaAlAs, as known as the poison, although the poison is relatively weak, in comparing with others, e.g. As₂O₃, AsCl₃ etc., and the amount is small, avoid putting the chip in acid or an alkali solution, heating it over 200°C or putting it into your mouth.
- (3) Avoid surge current or electrostatic discharge
The LD may be damaged or deteriorated by its own strong light if a large current is supplied to it, even if only a short pulse. Make sure that there is no surge current in the LD driving circuit by switches or else. Be careful to handle pick-up as it may be damaged in a moment by human electrostatic discharge. The pins of the LD are short-circuited by solder for protection during shipment.
For safety handling of an LD, grounding the human body, measuring equipments and jig is strongly recommended. And still it is further desirable to make use of mat on the platform and floor for handling the LD.
To open the short-circuit, remove the soldering quickly with a soldering iron whose metal part is grounded.
The temperature of the soldering iron should be less than 320°C (30W).

3. Actuator

- (1) The performance of the actuator may be effected if magnetic material is located nearby, since the actuator has a strong magnetic circuit. Do not permit dust to enter through the clearance of the cover.
- (2) Cleaning the lens
It may change the specifications by attaching dust or ash on the objective lens. Clean the lens with a cleaning paper dampened with a little water, not pressing lens with so much strength by the cleaning paper.

4. Metal Bearing

As the metal bearing of Cu-compound sintered alloy is impregnated with FROIL946P (*Part No. 529 0054 007), never fail to supply the bushing with the same lubricant at the time of replacing the pick-up.

5. Handling

Please handle the laser pick-up with holding the side base (rosin molded part).

When either a part of human body or some other things may happen to touch directly with the circuit part of P.W.Board, it may cause deterioration, take careful attention in handling this base.

6. Deterioration

As KSS-240 comprises built-in RF Amp and APC circuit, it resists stronger against external electrostatic damages than the former typed pickup. However, there is possibility of pickup deterioration in the following cases.

- (1) Low HF level, or with great numbers of jitters.
- (2) Tracking offset (EF Balance) is cut of order (Refer to "Confirmation Method of Adjustment " for confirmation on (1) and (2)).

NOTE FOR HANDLING OF LASER PICK-UP

DESCRIPTION OF THE COMPONENTS

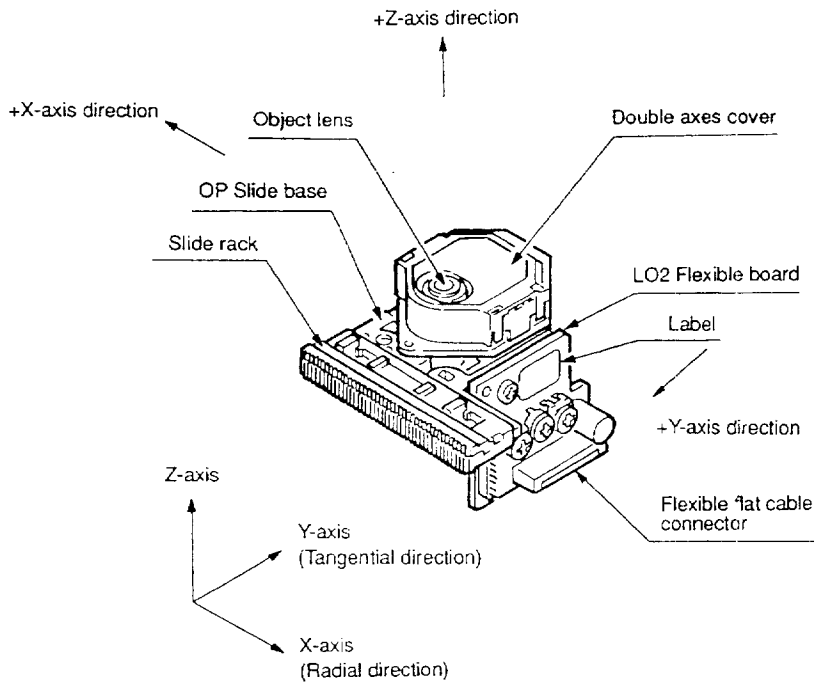

LABEL

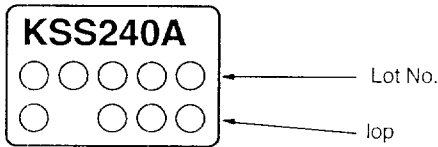

year
(last figure)
day month quality control No.
○ ○ ○ ○ ○ ○ ○ ○ ○ ○
but Oct. Nov. and Dec. are expressed by alphabetical letters of X, Y and Z.

quality control 10 1 10¹
○ ○ ○ ○
LD drive current

PIN CONNECTOR

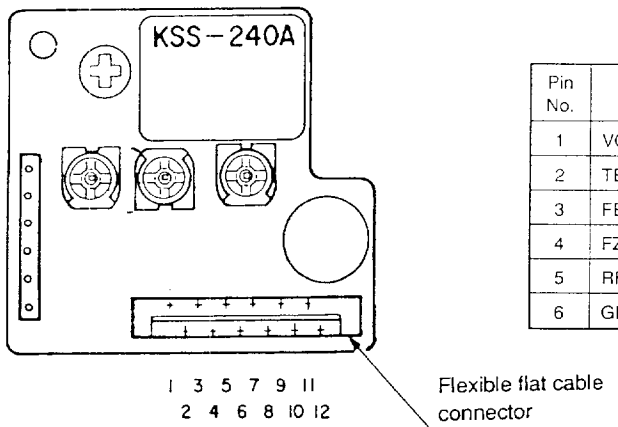

Pin No.	Description	Input/ Output	Pin No.	Description	Input/ Output
1	VC (+2.5V)	OUT	7	Vcc (-5V)	IN
2	TE (TRK ER signal)	OUT	8	LDC (LD Control)	IN
3	FE (FCS ER signal)	OUT	9	FCS+ (Double axes)	IN
4	FZC (FZC signal)	OUT	10	TFK+ (Double axes)	IN
5	RF (RF signal)	OUT	11	TRK- (Double axes)	IN
6	GND	IN	12	FCS- (Double axes)	IN

The expressed unit is by mA, with omission of the decimal point as for example, 56.5mA will be expressed as 565, but the head of English letter means the control in the manufacturing plant.

DISASSEMBLY

● TOP COVER

Remove 4 screws from both sides and 1 screw from Back Panel.

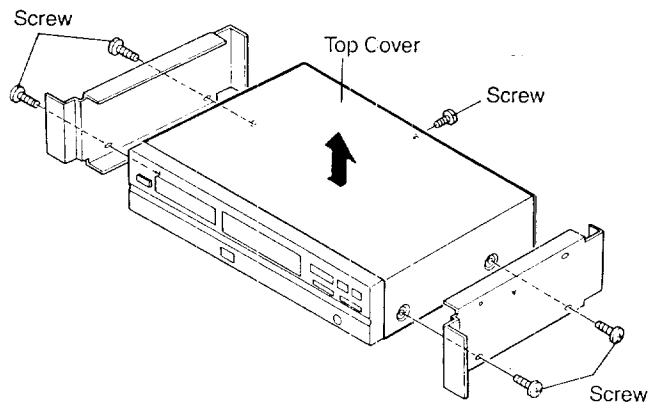

● FRONT PANEL

1. Pull Loader frame frontward, and remove loader panel.
2. Remove 2 front panel upper screws.
3. Undo 2 front panel upper hooks.
4. Pull front panel and undo 3 lower hooks.

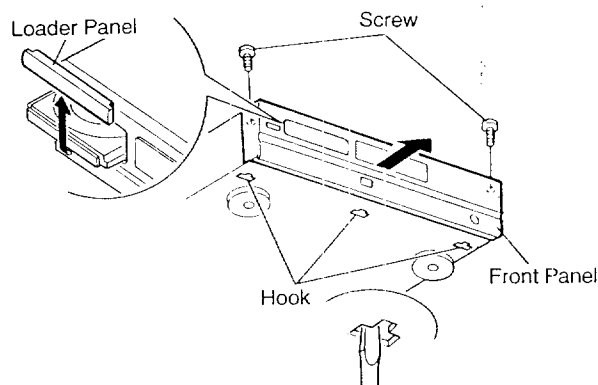

● MECHANISM UNIT

Remove 4 screws.

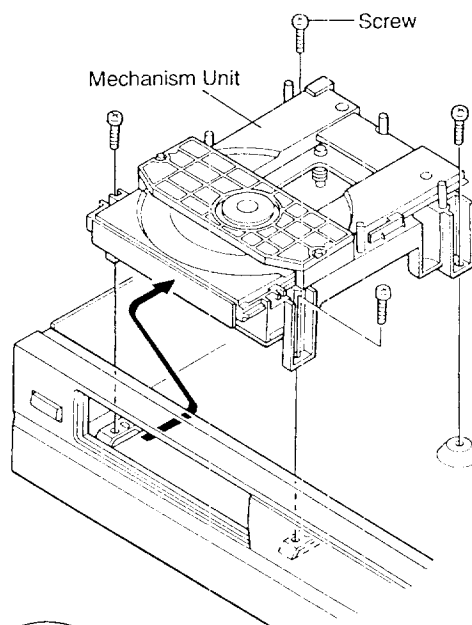

● CLAMPER

Remove 2 screws.
Pull clumper and undo 4 hooks.

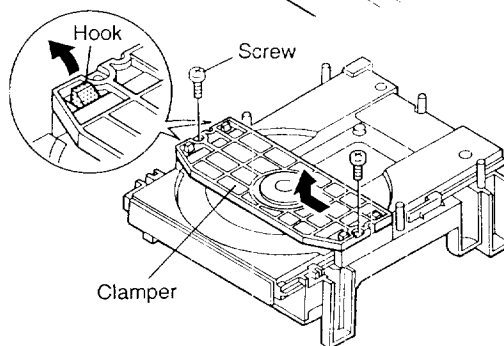

ADJUSTMENT

Microcomputer built in the unit, comprises service program to facilitate servo adjustment by pushing operation button.

1. Start service-program

- (1) Turn power switch OFF.
- (2) Shortcircuit pin ③ (SWCL) and ④ pin (SWOP) of connector (TP102) on P.W.B. (Main Unit)
(Caution) Do not touch other pins.
- (3) Turn power switch ON.
(Service program starts, and displays track number 01)

(Caution)

- When service program started normal operation of buttons will be defeated.

2. Service program function

Button	Function	Description
▲ OPEN/CLOSE	Opens or closes the disc holder.	<ul style="list-style-type: none"> ● Opens or closes only when disc is stopped. ● Operate other keys after open or close.
■ STOP	Stops system function.	<ul style="list-style-type: none"> ● Displays track number 01. ● Push when adjustment completed, or do it again.
▶ PLAY	Starts focus servo and disc turns.	<ul style="list-style-type: none"> ● Push when adjust tracking offset. ● When completed, displays track number 02
PAUSE	Starts focus servo, tracking servo, slide servo, spindle servo.	<ul style="list-style-type: none"> ● When PAUSE button is pushed, starts tracking servo and slide servo. ● When completed, track number 03.
Other button	No normal operation.	<ul style="list-style-type: none"> ● Do not operate buttons other than above. ● If misoperated, immediately turn power switch OFF.

(Caution)

- Do not use remote control during service program mode.

3. Adjustment

- (1) Location

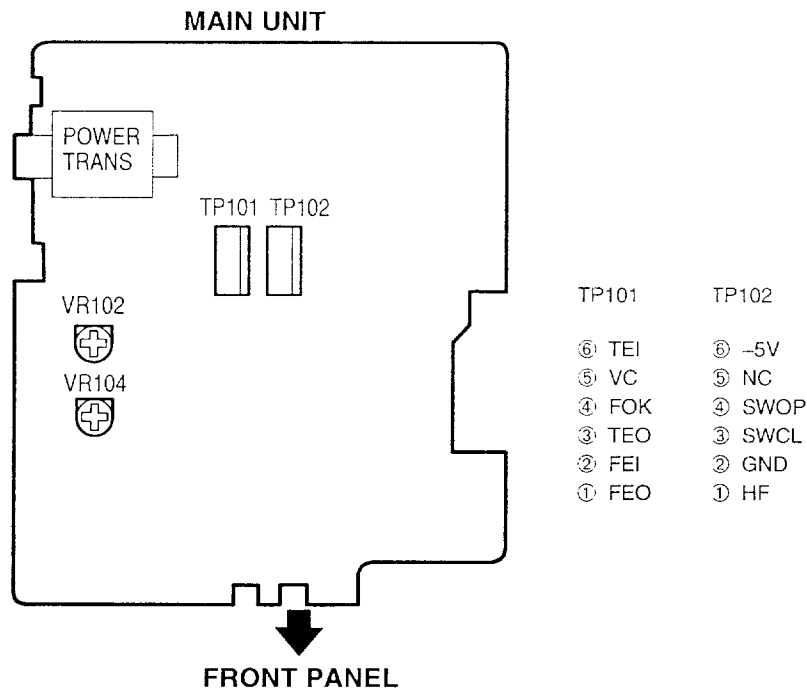

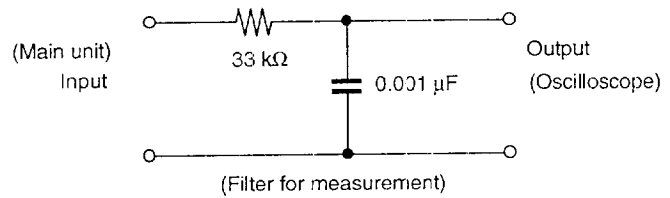

(2) Necessary equipment for adjustment

1. Dual trace oscilloscope
2. Reference disc (CA-1094)
3. Oscillator (10 Hz~ 10 kHz, 0 ~ 3 Vp-p)
4. Frequency counter (readable no less than 5 KHz)
5. Filter for measurement



(3) Preset

1.	Start service program.	
2.	Preset VR101, 102 as per right figure.	<p>VR102 (F-GAIN)  12 O'clock</p> <p>VR104 (F-GAIN)  12 O'clock</p>
3.	Step.-	<p>1. Focus gain (VR102)</p> <p>2. Tracking gain (VR104)</p>

4. Focus gain

Connection

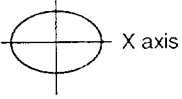
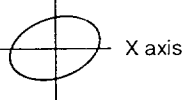
Oscillator	Counter	Oscilloscope		Adjust	Check	Step
		V	H			
1.1 kHz 2 Vp-p (±0.1 V)	1.1 kHz			VR102	<p>(Oscilloscope)</p> <p>Y axis</p>  <p>X axis</p> <p>Phase 90° Waveform not right</p> <p>Y axis</p>  <p>X axis</p>	<ol style="list-style-type: none"> 1. Push PAUSE. (Displays track number 03) 2. Connect oscillator. 3. Set oscillator to 1.1 kHz/2 Vp-p. 4. Switch oscilloscope input to X-Y mode. 5. Adjust VR101 [F-GAIN] to symmetrize Lissajous figures to X-Y axes.

5. Tracking gain

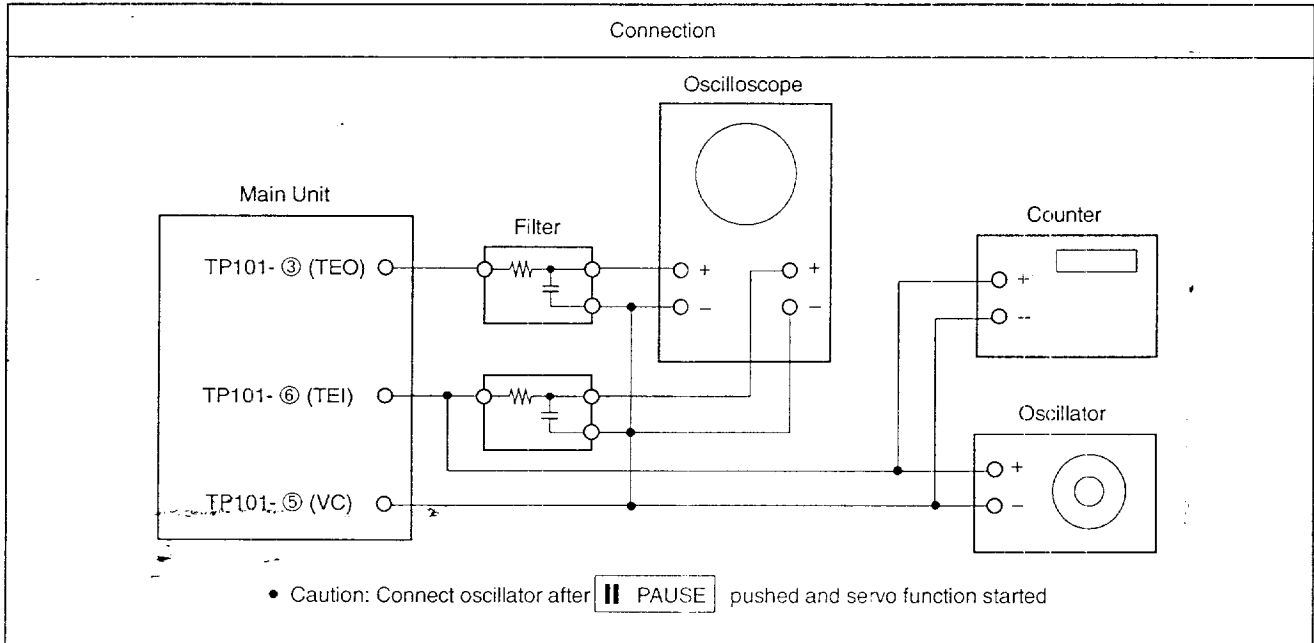

Oscillator	Counter	Oscilloscope		Adjust (Volume)	Check (Oscilloscope)	Step
		V	H			
<ul style="list-style-type: none"> ● 3.3 kHz (±120 Hz) ● 0.8 Vp-p (±0.1V) 	3.3 kHz (±120 Hz)	<ul style="list-style-type: none"> ● DC range ● X-Y mode 	VR104	(Oscilloscope) Y axis X axis Phase 90° Waveform not right Y axis X axis	<ol style="list-style-type: none"> 1. Push PAUSE. (Displays track number 03) 2. Connect oscillator. 3. Set oscillator to 3.3 kHz/0.8 Vp-p. 4. Switch oscilloscope input to X-Y mode. 5. Adjust VR104 [T-GAIN] to symmetrize Lissajous figures to X-Y axes. 	

6. Tracking offset (E/F Balance)

Connection			
Oscilloscope		Check	Step
V	H	(Oscilloscope)	
0.1v/div	1-2 ms/div	$\frac{A - B}{A + B} < 20\%$	<ol style="list-style-type: none"> 1. Push ▲ OPEN/CLOSE and load disc holder reference disk. 2. Push ▲ OPEN/CLOSE and close disc holder. 3. Push ▶ PLAY to turn disc. (Displays track number 02) 4. Short (+)(-) of oscilloscope and check the base line. 5. Confirm that upper and lower amplitude of the waveform is symmetric against 0V.

7. HF level

Connection			
Oscilloscope		Check	Step
V	H	(Oscilloscope)	
50mV/div or 20mV/div	0.2μ/div or 0.5μ/div	<p style="text-align: center;">A=1.2±0.3Vp-p</p>	<ol style="list-style-type: none"> 1. Push PAUSE. (Displays track number 03) 2. Check HF level of oscilloscope. 3. Confirm that the waveform is in good shape. (ϕ pattern in center must be able to discriminate clearly.)
<ul style="list-style-type: none"> • Set input mode to ALTERNATE or CHOPPER. 			

HEAT RUN MODE FUNCTION

Heat Run Mode

1) To activate

While hold pushing ►►, ◀◀, ►► and ◀◀ keys simultaneously, turn the unit power on. The remote control sensor indicator will light to show that the unit is shifted in Heat Run mode.

Be sure to load the disc previously.

Press the disc holder open/close button (▲ OPEN/CLOSE) to cancel Heat Run mode.

★ This mode functions only for a disc with 21 pieces of music or more. For a disc with 20 pieces of music or lesser, please do not use.

2) Operation

During the Heat Run mode to shift the unit in Play mode makes the unit replays from the first music after opens the loader once and re-closes it when finish playing the last track (comes into lead out).

Hereafter, operates open/close of loader, servo on, reading of TOC, and playing repeatedly, and repeats playing the two tracks; the first and the last ones.

3) Error Message

When the system error occurs while in Heat Run mode, the following error message will display on the Track No. indicator and stops operation.

1. E1

At the time of Focus Servo does not activate.

2. E2

When unable to detect synchronous pattern however the disc is in rotating. (GFS does not drive.)

3. E3

No synchronous pattern can be detected while in Play mode. (No GFS drives.)

4. E4

When TOC is unreadable in despite of servo is activated.

5. E5

In case of loader malfunctions. (Unable to turn on the switch.)

6. E6

The inner circle switch of Pick-up does not turn off.

7. E7

The inner circle switch of Pick-up does not turn on.

★ The number of operation up to the stop will be displayed on the minute and second portion of the indicator.

IC TERMINAL FUNCTION LIST

CXD2500BQ Terminal Function

Terminal No.	Symbol	I/O	Terminal Function
1	FOK	I	Input terminal for OK focussing. Use for Servo-autosequencer.
2	FSW	O	Output to shift time constant of output filter for spindle motor.
3	MON	O	ON/OFF control output for spindle motor.
4	MDP	O	Servo control for spindle motor.
5	MDS	O	Servo control for spindle motor.
6	LOCK	O	Sampling GFS by 460 Hz and if it is "H", delivers "H" ; if it is continuously "L" 8 times, delivers "L".
7	NC	—	
8	VCOO	O	Oscillation current output for analog EFM PLL.
9	VCOI	I	Oscillation current output for analog EFM PLL. f LOCK=8.6436MHz.
10	TEST	I	TEST output. Normally GND.
11	PDO	O	Charge pump output for analog EFM PLL.
12	Vss		GND.
13	NC	—	
14	NC	—	
15	NC	—	
16	VPCO	O	Charge pump output for variable pitch PLL.
17	VCKI	O	Clock input from external VCO for variable pitch. fc center=16.9344MHz.
18	FILO	O	Filter output for master PLL. (slave=digital PLL)
19	FILI	I	Filter input for master PLL.
20	PCO	O	Charge pump output for master PLL.
21	AVss		Analog GND.
22	CLTV	I	Control voltage output for master VCO.
23	AVDD		Analog power supply (+5V).
24	RF	I	EFM signal input.
25	TEST2	I	Put to GND.
26	TEST3	I	Put to GND.
27	ASYO	O	Full swing output for EFM. (L=Vss, H=VDD).
28	TEST4	I	Put to GND.
29	NC	—	
30	PSSL	I	Input to shift output mode of audio data. Serial output at L; parallel output at H.
31	WDCK	O	D/A Interface for 48 bit slot. Word-clock f=2 Fs.
32	LRCK	O	D/A Interface for 48 bit slot. LR-clock f= Fs.
33	VDD		Power supply (+5V).
34	DA16	O	At PSSL=1 for DA16 (MBS) output; PSSL=0 for serial data of 48 bit slot. (2s'COMP, MSB first).
35	DA15	O	At PSSL=1 for DA15 output; PSSL=0 for bit clock of 48 bit slot.
36	DA14	O	At PSSL=1 for DA14 output; PSSL=0 for serial data of 64 bit slot. (2s'COMP, LSB first).
37	DA13	O	At PSSL=1 for DA13 output; PSSL=0 for bit clock of 64 bit slot.
38	DA12	O	At PSSL=1 for DA12 output; PSSL=0 for LR clock of 64 bit slot.
39	DA11	O	At PSSL=1 for DA11 output; PSSL=0 for GTOP output.
40	DA10	O	At PSSL=1 for DA10 output; PSSL=0 for XUGF output.
41	DA09	O	At PSSL=1 for DA09 output; PSSL=0 for XPLCK output.
42	DA08	O	At PSSL=1 for DA08 output; PSSL=0 for GFS output.
43	DA07	O	At PSSL=1 for DA07 output; PSSL=0 for RFCK output.
44	DA06	O	At PSSL=1 for DA06 output; PSSL=0 for C2PO output.
45	DA05	O	At PSSL=1 for DA05 output; PSSL=0 for XRAOF output.
46	DA04	O	At PSSL=1 for DA04 output; PSSL=0 for MNT3 output.
47	DA03	O	At PSSL=1 for DA03 output; PSSL=0 for MNT2 output.
48	DA02	O	At PSSL=1 for DA02 output; PSSL=0 for MNT1 output.
49	DA01	O	At PSSL=1 for DA01 output; PSSL=0 for MNT0 output.
50	APTR	O	Control output for aperture compensation. In H for R-ch.
51	APTL	O	Control output for aperture compensation. In H for L-ch.

Terminal No.	Symbol	I/O	Terminal Function
52	Vss		GND.
53	XTAI	I	X'tal oscillation circuit input. By selecting of mode, f=16.9344MHz or 33.8688MHz.
54	XTAO	O	X'tal oscillation circuit input. f=16.9344MHz.
55	XTSL	I	Selection input terminal of X'tal. "L" for X'tal 16.9344MHz; H for 33.8688MHz.
56	FSTT	O	2/3 Dividing output of 53 and 54 terminal. No change by variable pitch.
57	C4M	O	4.2336MHz output. When variable pitched, simultaneously changes.
58	C16M	O	16.9344MHz output. When variable pitched, simultaneously changes.
59	MD2	I	Digital-out ON/OFF control. ON at H; OFF at L.
60	DOUT	O	Digital-out output terminal.
61	EMPH	O	When playback disc emphasized, outputs H; otherwise outputs L.
62	WFCK	O	WFCK (Write Flame Clock) output.
63	SCOR	O	Output of subcode sync. S0+S1. H output when either one detected.
64	SBSO	O	Serial output of Sub P-W.
65	EXCK	I	Clock input for SBSO read-out.
66	SQSO	O	Output for Sub Q 80 bits and PCM peak level 16 bits.
67	SQCK	I	Clock input for SQSO read-out.
68	MUTE	I	Mute at H; remove mute at L.
69	SENS	O	SENS output. Outputs to CPU.
70	XRST	I	System reset input. Resets at "L".
71	DATA	I	Input of serial data from CPU.
72	XLAT	I	Input for latch from CPU. Latches serial data at release.
73	Vdd		Power supply (+5V).
74	CLOCK	I	Serial data transfer clock input from CPU.
75	SEIN	I	SENS input from SSP.
76	CNIN	I	Input of tracking pulse.
77	DATO	O	Serial data output to SSP.
78	XLTO	O	Serial data latch output to SSP.
79	CLKO	O	Serial data transfer clock output to SSP.
80	MIRR	I	Mirror signal input. Use for track jump for over 128 tracks, using autosequencer.

CXD2500BQ

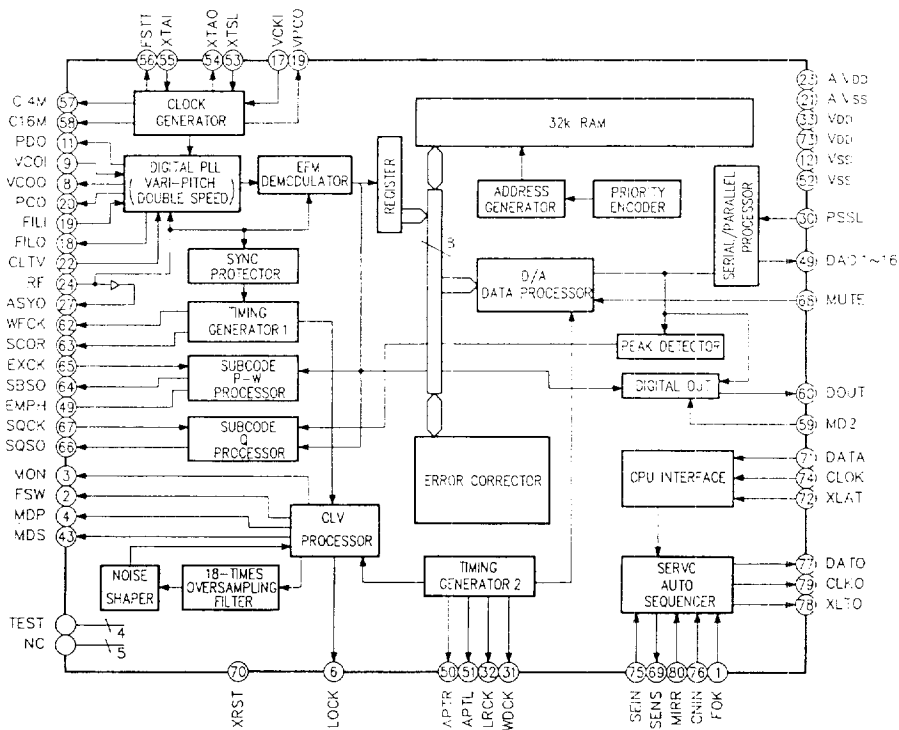

CXA1372S Terminal Function

Terminal No.	Symbol	I/O	Terminal Function
1	TE	I	Tracking error signal input terminal.
2	TDFCT	I	Capacitor connecting terminal for time constant at the time of defect.
3	ATSC	I	Input terminal of ATSC detecting window comparator.
4	FZC	I	Input terminal of focus zero-cross comparator.
5	FE	I	Focus error signal input terminal.
6	FDFCT	I	Capacitor connecting terminal for time constant at the time of defect.
7	Vc	I	Mid-point voltage input terminal.
8	FGD	I	In case of reducing higher range gain of focus servo, connect a capacitor between this terminal and terminal number (9).
9	FS3	I	Shifts higher range gain of focus servo by FS3 ON/OFF.
10	FLB	I	Terminal for external time constant to increase lower range of focus servo.
11	FEO	O	Focus drive output.
12	FE-	I	Reverse input terminal for focus amplifier.
13	SRCH	I	Terminal for external time constant to make focus search waveform.
14	TGU	I	Terminal for external time constant to shift higher range gain of tracking.
15	TG2	I	Terminal for external time constant to shift higher range gain of tracking.
17	TAO	O	Tracking drive output.
18	TA-	I	Reverse input terminal for tracking amplifier.
19	SL+	I	Non-reverse input terminal for sled amplifier.
20	SLO	O	Sled drive output.
21	SL-	I	Reverse input terminal for sled amplifier.
22	FSET	I	Terminal to compensate peak in focus/tracking phase.
23	ISET	I	Delivers a current to set the height of focus search, track jump, and sled kick.
24	SSTOP	I	Terminal for limit switch ON/OFF to detect disc innermost circle.
26	DIRC	I	Terminal is used at the time of 1 track jump. A 47 kohm pull up resistor is included.
27	LOCK	I	Reckless drive protection circuit of sled; activates at "L". A 47k ohm pull up resistor is included.
28	CLK	I	Serial data transfer clock input from CPU.
29	XLT	I	Latch input from CPU.
30	DATA	I	Serial data input from CPU.
31	XRST	I	Reset input terminal. Resets at "L".
32	C.OUT	O	Terminal to output signal for track number count.
33	SENS	O	Terminal to output FZC, AS, TZC, SSTOP by command from CPU.
35	MIRR	O	Output terminal for MIRR comparator.
36	DFCT	O	Output terminal for DEFECT comparator.
37	ASY	I	Input terminal for auto-symmetric control.
38	EFM	O	Output terminal for EFM comparator.
39	FOK	O	Output terminal for focus OK (FOK) comparator.
40	CC1	O	DEFECT bottom hold output terminal.
41	CC2	I	Input terminal to input DEFECT bottom hold output by capacitance combination.
43	CB	I	Capacitor connecting terminal for DEFECT bottom hold.
44	CP	I	MIRR hold capacitor connecting terminal. A non-reverse input terminal for MIRR comparator.
45	RFI	I	Input terminal to input RF summing amplifier output by capacitance combination.
46	RFO	O	Output terminal for RF summing amplifier. Check point for eye pattern.
48	TZC	I	Tracking zero-cross comparator input terminal.

CXA1372S

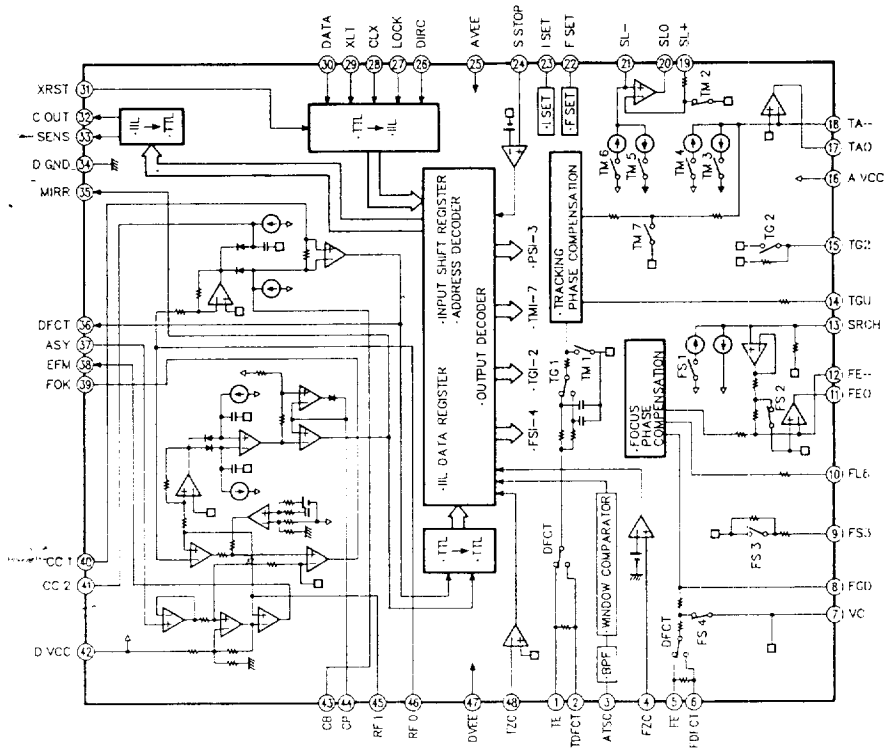

NOTE FOR PARTS LIST

- Part indicated with the mark "●" are not always in stock and possibly to take a long period of time for supplying, or in some case supplying of part may be refused.
- When ordering of part, clearly indicate "1" and "I" (i) to avoid mis-supplying.
- Ordering part without stating its part number can not be supplied.
- Part indicated with the mark "★" is not illustrated in the exploded view.
- Not including Carbon Film ±5%, 1/4W Type in the P.W.Board parts list. (Refer to the Schematic Diagram for those parts.)

WARNING:

Parts marked with this symbol have critical characteristics. Use ONLY replacement parts recommended by the manufacturer.

● Resistors

Ex.: RN 14K 2E 182 G FR
 Type Shape Power Resist- Allowable Others
 and- ance error
 performance

RD : Carbon	2B : 1/8W	F : ±1%	P : Pulse-resistant type
RC : Composition	2E : 1/4W	G : ±2%	NL : Low noise type
RS : Metal oxide film	2H : 1/2W	J : ±5%	NB : Non-burning type
RW : Winding	3A : 1W	K : ±10%	FR : Fuse-resistor
RN : Metal film	3D : 2W	M : ±20%	F : Lead wire forming
RK : Metal mixture	3F : 3W		
	3H : 5W		

• Resistance

1 8 2 ⇒ 1800 ohm = 1.8 kohm
 Indicates number of zeros after effective number.
 2-digit effective number.

• Units: ohm

1 R 2 ⇒ 1.2 ohm
 1-digit effective number.
 2-digit effective number, decimal point indicated by R.

• Units: ohm

• Capacity (electrolyte only)

2 2 2 ⇒ 2200µF
 Indicates number of zeros after effective number.
 2-digit effective number.

• Units: µF.

2 R 2 ⇒ 2.2µF
 1-digit effective number.
 2-digit effective number, decimal point indicated by R.

• Units: µF.

● Capacitors

Ex.: CE 04W 1H 2R2 M BP
 Type Shape Dielectric Capacity A lowable Others
 and- strength error
 performance

CE : Aluminum foil electrolytic	0J : 6.3V	F : ±1%	HS : High stability type
CA : Aluminum solid electrolytic	1A : 10V	G : ±2%	BP : Non-polar type
CS : Tantalum electrolytic	1C : 15V	J : ±5%	HR : Ripple-resistant type
CO : Film	1E : 25V	K : ±10%	DL : For charge and discharge
CK : Ceramic	1V : 35V	M : ±20%	HF : For assuring high frequency
CC : Ceramic	1H : 50V	Z : +8%	U : UL part
CP : Oil	2A : 100V	-20%	C : CSA part
CM : Mica	2B : 125V	P : +10%	W : UL-CSA type
CF : Metallized	2C : 160V	-0%	F : Lead wire forming
CH : Metallized	2D : 200V	C : ±0.25pF	
	2E : 250V	D : ±0.5pF	
	2H : 500V	= Others	
	2J : 630V		

• Capacity (except electrolyte)

2 2 2 ⇒ 2200pF = 0.0022µF
 (More than 2) — Indicates number of zeros after effective number.
 2-digit effective number.

• Units: µF.

2 2 1 ⇒ 220pF
 (0 or 1) — Indicates number of zeros after effective number.
 2-digit effective number.

• Units: pF.

• When the dielectric strength is indicated in AC, "AC" is included after the dielectric strength value.

PARTS LIST OF P.W.BOARD
3U-2599 MAIN UNIT

Ref. No.	Part No.	Part Name	Remarks
SEMICONDUCTOR GROUP			
IC102	262 1305 001	IC CXA1372S	
IC103	263 0223 006	IC TL4558P-B	
IC105,106	263 0223 006	IC TL4558P-B	
IC201	262 1846 007	IC M38173M6-161FP	
IC202	262 1819 005	IC CXD2500BQ	
IC203	262 0824 004	IC SN74LS624N	
IC204	262 1352 009	IC TC74HCT04AP	
IC300	262 1761 001	IC SM5841BP	
IC302,303	262 1409 004	IC PCM61P-L	
IC501	263 0693 005	IC M5290P	
IC502,503	268 0073 905	IC Protector ICP-N15T	
IC701	262 0591 007	IC HD74HC00P	
IC705	263 0223 006	IC TL4558P-B	
TR109	274 0036 905	Transistor 2SD468(C)TF	
TR110	272 0025 907	Transistor 2SB562(C)TF	
TR111	274 0036 905	Transistor 2SD468(C)TF	
TR112	272 0025 907	Transistor 2SB562(C)TF	
TR113	274 0036 905	Transistor 2SD468(C)TF	
TR114	272 0025 907	Transistor 2SB562(C)TF	
TR115	274 0136 009	Transistor 2SD1913	
TR116	272 0025 907	Transistor 2SB562(C)TF	
TR117	274 0036 905	Transistor 2SD468(C)TF	
TR118	272 0025 907	Transistor 2SB562(C)TF	
TR501	274 0136 009	Transistor 2SD1913	
TR502	272 0093 007	Transistor 2SB1274	
TR503	271 0192 905	Transistor 2SA933(S)TP	
TR600,601	274 0160 907	Transistor 2SD2144STPU	
TR702	269 0014 909	Transistor DTA124XS(22K-47K)T	Built in Resistor
TR703	269 0020 906	Transistor DTC114ES(10K-10K)T	Built in Resistor
TR704	271 0192 905	Transistor 2SA933(S)TP	
TR706,707	274 0160 907	Transistor 2SD2144STPU	
D207	276 0503 900	Diode 1SS198TE	
D501-506	276 0613 900	Diode 1A3-I	
D507	276 0483 907	Zener Diode HZS30-1TD	
D508	276 0464 900	Zener Diode HZS7A-1TD	
D601-608	276 0432 903	Diode 1SS270A TE	
D701	276 0432 903	Diode 1SS270A TE	
RESISTORS GROUP (Not included Carbon film ±5%, 1/4W Type)			
VR102,104	211 6093 954	Adjust 22kohm	V06PB223(IM)
VR300,301	211 6093 970	Adjust 100kohm	V06PB104(IM)
CAPACITORS GROUP			
C106	253 9030 934	Ceramic 0.0033μF/25V	CK45=1E332KT
C107	253 9035 926	Ceramic 0.027μF/25V	CK45=1E273KT
C108	253 9030 921	Ceramic 0.0022μF/25V	CK45=1E222KT
C109-112	256 1034 979	Metallized 0.1μF/50V	CF93A1H104JT
C113	254 4337 910	Electrolytic 6.8μF/50V	CE04W1H6R8MT
C114	256 1035 910	Metallized 0.22μF/50V	CF93A1H224JT
C116	253 9030 963	Ceramic 0.01μF/25V	CK45=1E103KT

Ref. No.	Part No.	Part Name	Remarks
C117	253 9039 906	Ceramic 0.1μF/25V	CK45=1E104ZT
C118,119	253 1180 921	Ceramic 0.001μF/50V	CK45B1H102KT
C120	253 9039 906	Ceramic 0.1μF/25V	CK45=1E104ZT
C121	253 1181 904	Ceramic 0.01μF/50V	CK45F1H103ZT
C122,123	254 4260 919	Electrolytic 0.22μF/50V	CE04W1HR22MT
C124	253 9030 963	Ceramic 0.01μF/25V	CK45=1E103KT
C125	253 9030 992	Ceramic 0.033μF/25V	CK45=1E333KT
C126	253 9030 963	Ceramic 0.01μF/25V	CK45=1E103KT
C127	253 9030 934	Ceramic 0.0033μF/25V	CK45=1E332KT
C128	253 9031 962	Ceramic 0.0027μF/25V	CK45=1E272KT
C129	253 9039 906	Ceramic 0.1μF/25V	CK45=1E104ZT
C130	253 1179 990	Ceramic 560pF/50V	CK45B1H561KT
C131	253 9031 988	Ceramic 0.0056μF/25V	CK45=1E562KT
C132	253 4538 910	Ceramic 75pF/50V	CK45SL1H750JT
C133	253 4536 909	Ceramic 10pF/50V	CC45SL1H100DT
C134	256 1034 979	Metallized 0.1μF/50V	CF93A1H104JT
C135	254 3055 918	Electrolytic 10μF/35V Bipolar	CE04D1V100MBPT
C136	253 4538 949	Ceramic 100pF/50V	CC45SL1H101JT
C140	253 4538 910	Ceramic 75pF/50V	CC45SL1H750JT
C141	253 9030 934	Ceramic 0.0033μF/25V	CK45=1E332KT
C142	253 9039 906	Ceramic 0.1μF/25V	CK45=1E104ZT
C164	253 4536 941	Ceramic 15pF/50V	CC45SL1H150JT
C166	253 4536 941	Ceramic 15pF/50V	CC45SL1H150JT
C168	253 4538 910	Ceramic 75pF/50V	CC45SL1H750JT
C170,171,173	254 4254 938	Electrolytic 47μF/16V	CE04W1C470MT
C174	253 9039 906	Ceramic 0.1μF/25V	CK45=1E104ZT
C202-204	253 1181 904	Ceramic 0.01mF/50V	CK45F1H103ZT
C205	253 9039 906	Ceramic 0.1μF/25V	CK45=1E104ZT
C210	253 9031 904	Ceramic 0.047μF/25V	CK45=1E473KT
C211	253 1180 947	Ceramic 0.0015μF/50V	CK45B1H152KT
C212,213	253 9039 906	Ceramic 0.1μF/25V	CK45=1E104ZT
C214	254 4250 932	Electrolytic 220μF/6.3V	CE04W0J221MT
C215,216	253 9039 906	Ceramic 0.1μF/25V	CK45=1E104ZT
C217	254 4254 941	Electrolytic 100μF/16V	CE04W1C101MT
C220	254 4260 922	Electrolytic 0.33μF/50V	CE04W1HR33MT
C222	253 4537 937	Ceramic 36pF/50V	CC45SL1H360JT
C223,224	253 4536 941	Ceramic 15pF/50V	CC45SL1H150JT
C227	253 1181 904	Ceramic 0.01μF/50V	CK45F1H103ZT
C256	253 1180 921	Ceramic 0.01μF/50V	CK45B1H102KT
C257,258	253 1180 921	Ceramic 0.001μF/50V	CK45B1H102KT
C259	253 1181 904	Ceramic 0.01μF/50V	CK45F1H103ZT
C300,301	254 4254 954	Electrolytic 220μF/16V	CE04W1C221MT
C302	253 9039 906	Ceramic 0.1μF/25V	CK45=1E104ZT
C304	253 9039 906	Ceramic 0.1μF/25V	CK45=1E104ZT
C306,307	253 1180 905	Ceramic 680pF/50V	CK45B1H681KT
C308,309	253 1121 906	Ceramic 0.0056μF/50V	CK45B1H562KT
C311	254 4254 941	Electrolytic 100μF/16V	CE04W1C101MT
C327	253 9039 906	Ceramic 0.1μF/25V	CK45=1E104ZT
C328	254 4254 925	Electrolytic 33μF/16V	CE04W1C330MT
C350	253 9039 906	Ceramic 0.1μF/25V	CK45=1E104ZT
C353	253 9039 906	Ceramic 0.1μF/25V	CK45=1E104ZT
C501	254 4254 792	Electrolytic 2200μF/16V	CE04W1C222MC
C502	254 4255 717	Electrolytic 4700μF/16V	CE04W1C472MC
C503	254 4254 954	Electrolytic 220μF/16V	CE04W1C221MT
C505	254 4260 948	Electrolytic 1μF/50V	CE04W1H010MT
C507	254 4262 946	Electrolytic 47μF/63V	CE04W1J470MT
C508	254 4261 921	Electrolytic 100μF/50V	CE04W1H101MT

Ref. No.	Part No.	Part Name	Remarks
C509,510	254 4258 934	Electrolytic 33μF/35V	CE04W1V330MT
C511	254 4260 964	Electrolytic 3.3μF/50V	CE04W1H3R3MT
C512	253 1122 905	Ceramic 0.0068μF/50V	CK45B1H682KT
C600,601	253 1181 904	Ceramic 0.01μF/50V	CK45F1H103ZT
C704	254 4254 954	Electrolytic 220μF/16V	CE04W1C221MT
C710,711	254 4368 934	Electrolytic 100μF/25V	CE04W1E101MT
C716,717	253 4537 982	Ceramic 56pF/50V	CC45SL1H560JT
C718,719	254 4250 929	Electrolytic 100μF/6.3V	CE04W0J101MT
C720,721	254 4254 941	Electrolytic 100μF/16V	CE04W1C101MT
C730	253 1181 904	Ceramic 0.01μF/50V	CK45F1H103ZT
C731	253 4538 949	Ceramic 100pF/50V	CC45SL1H101JT
C732	253 9039 906	Ceramic 0.1μF/25V	CK45=1E104ZT
C733	253 9039 906	Ceramic 0.1μF/25V	CK45=1E104ZT
C800	253 9039 906	Ceramic 0.1μF/25V	CK45=1E104ZT
OTHER PARTS			
X200	399 0165 007	X'Tal (16.9344MHz)	
X201	399 0111 006	CST4.23MGW040	
RM601	499 0264 004	Remote Sensor (GP1U571)	
	412 3951 016	Reflector	
PT300	231 8063 009	Pulse Trans	
HJ601	204 8364 007	Head Phone jack	
JK701	204 8262 002	1P Pin Jack (Digital out)	
JK702	204 8311 021	2P Pin Jack(FIX out)	
SW600	212 1039 000	1P Push Switch (Power ON-OFF)	
LCD601	393 4110 005	FL Tube (FIP8NM6A)	
CB101	205 0321 054	5P Connector Base(Red)	
CB102	205 0343 058	5P Connector Base (KR-PH)	
CB103	205 0683 006	FFC Connector Base(12P)	
CB203	205 0736 021	31P FFC Connector Base	
CB500	205 0581 001	2P VH Connector Base	
CB601	205 0535 060	4P Connector Base	
CB602	205 0736 021	31P FFC Connector Base	
CS601	205 0637 007	4P Connector Socket	
TP101,102	205 0190 065	6P NH Connector Base	
△	233 5907 012	Power Transformer (E3)	U.S.A. Canada
△	233 6145 006	Power Transformer (E2)	Europe U.K
△	233 5822 003	Power Transformer (E1)	Multi-Voltage
△	212 4698 008	Voltage Selector (D)	Multi-Voltage Models Only

PACKING & ACCESSORIES

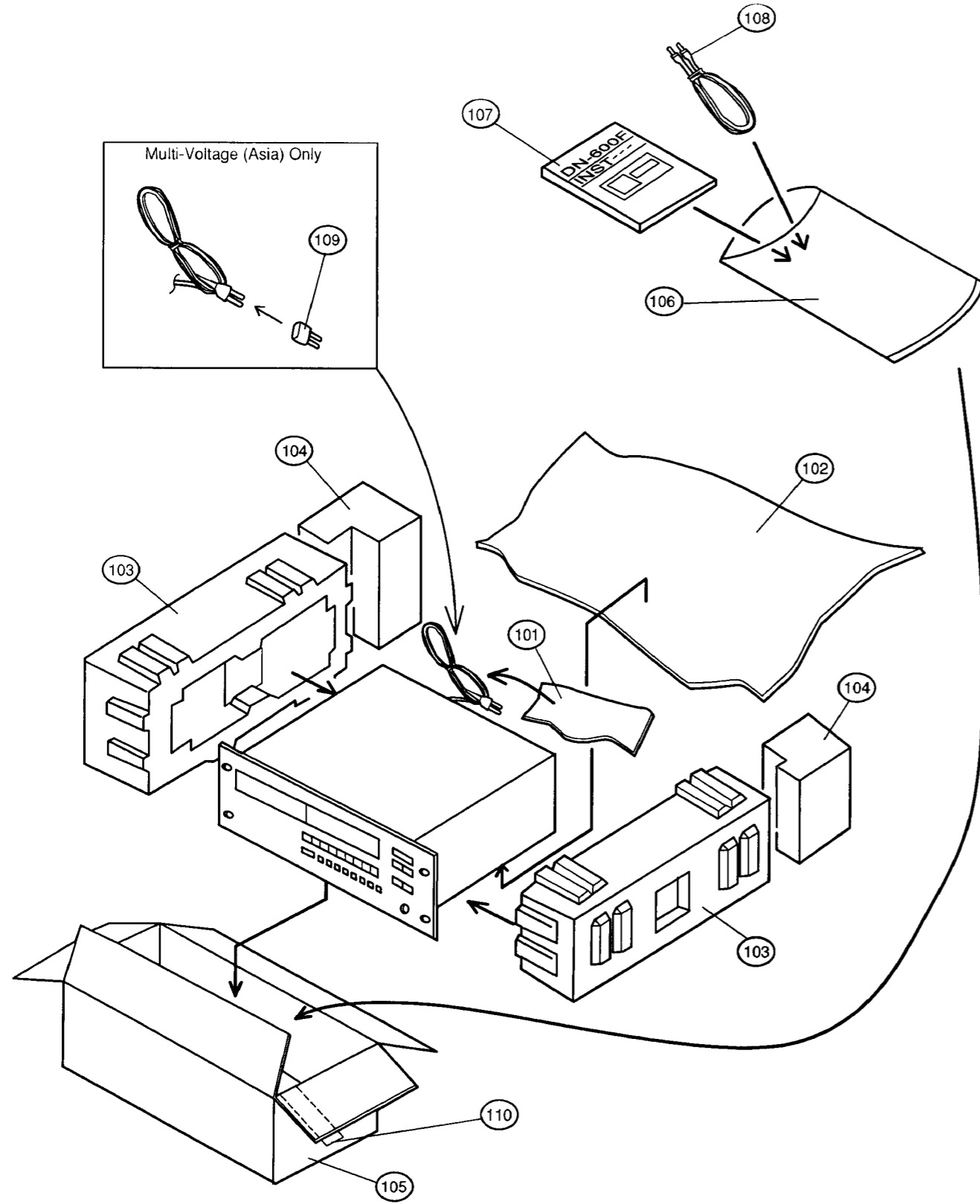

501 1739 174: (U.S.A., Canada, Europe and Multi-Voltage Model)
 501 1739 187: (U.K. Model)

PARTS LIST OF PACKING & ACCESSORIES

Ref. No.	Part No.	Part Name	Remarks	Q'ty
101	504 0092 060	STYRENE PAPER	For AC Cord	1
101	504 0170 005	PROTECTOR SHEET	U.K. only	1
102	505 0102 092	STYRENE PAPER		1
103	503 1130 009	CUSHION		2
104	503 1152 003	SUB CUSHION	U.K. only	2
105	501 1739 174	CARTON CASE	U.S.A., Canada, Europe, Multi-Voltage (Asia)	1
105	501 1739 187	CARTON CASE	U.K. only	1
106	505 0038 030	POLY COVER	For Accessories	1
107	511 2683 006	INST. MANUAL		1
108	203 2360 004	2P PIN CORD		1
△ 109	203 0044 002	PLUG ADAPTER	Multi-Voltage (Asia) only	1
110	515 0692 004	DEL WARRANTY COM	U.S.A. only	1

PARTS LIST OF EXPLODED VIEW

Ref. No.	Part No.	Part Name	Remarks
● 1	3U-2599	MAIN UNIT ASS'Y	
└ 1-1	—	MAIN UNIT	
└ 1-2	—	DISPLAY / KEY UNIT	
└ 1-3	—	HEAD PHONE UNIT	
└ 1-4	—	POWER SWITCH UNIT	
2	204 8364 007	HEAD PHONE JACK	HJ601
3	393 4110 005	FL TUBE (FIP8NM6A)	
4	212 1039 000	1P PUSH SWITCH	SW600
6	337 0028 007	CD MECHA. UNIT (FG-70)	
● 7	122 0187 113	TOP COVER SPACER	
● 9	144 2411 104	FRONT PANEL	
● 10	146 1392 408	SUB PANEL Ass'y	
11	113 1540 195	SERIES KNOB	
12	113 9245 285	TENKEY	
13	113 1541 055	FUNCTION KNOB	
14	113 1561 051	MANUAL SEARCH KNOB	
15	009 0011 012	31P FFC CORD	
17	113 1357 281	POWER SWITCH KNOB	
18	146 1394 147	LOADER PANEL	
21	473 7508 017	3×10 CBTS(P)-B	
22	473 7002 021	3×8 CBTS(S)-B	
24	473 7002 005	3×6 CBTS(S)-Z	
25	473 7007 071	4×12 CBTS(S)-ZNB	
27	204 8262 002	1P PIN JACK	JK701
● 28	461 0740 002	SHEET	
29	461 0706 114	FOOT SHEET	
● 30	411 0962 801	CHASSIS	
● 31	105 1139 039	REAR PANEL (E3)	U.S.A., Canada
●	105 1139 042	REAR PANEL (E2, EK)	Europe, U.K.
●	105 0993 111	REAR PANEL (E1)	Multi-Voltage (Asia)
● 33	441 1132 204	BOTTOM PLATE	
● 34	443 0518 003	P.C.B. HOLDER	
37	204 8311 021	2P PIN JACK	JK 702
△ 38	233 5807 012	POWER TRANSFORMER (E3)	U.S.A. Canada
△	233 6145 006	POWER TRANSFORMER (E2)	Europe, U.K.
△	233 5822 003	POWER TRANSFORMER (E1)	Multi-Voltage (Asia) only
△ 40	206 2110 004	AC CORD WITH CONNECTOR(E3)	U.S.A., Canada
△	206 2089 106	AC CORD WITH CONNECTOR(E2)	Europe only
△	206 2128 009	AC CORD WITH CONNECTOR(EK)	U.K. only
△	206 2088 000	AC CORD WITH CONNECTOR(E1)	Multi-Voltage(Asia) only
△ 41	445 0056 008	CORD BUSH	
● 43	102 0425 224	TOP COVER	
● 44	412 3901 008	MOUNT BRACKET	
45	411 1143 001	SELECTOR BRACKET	Multi-Voltage(Asia) only

WARNING:

- Parts marked with " △ " and/or shading have special characteristics important to safety.
- Part indicated with the mark " ● " are not always in stock and possibly to take a long period of time for supplying, or in some case supplying of part may be refused.

EXPLODED VIEW

1 2 3 4 5 6 7 8

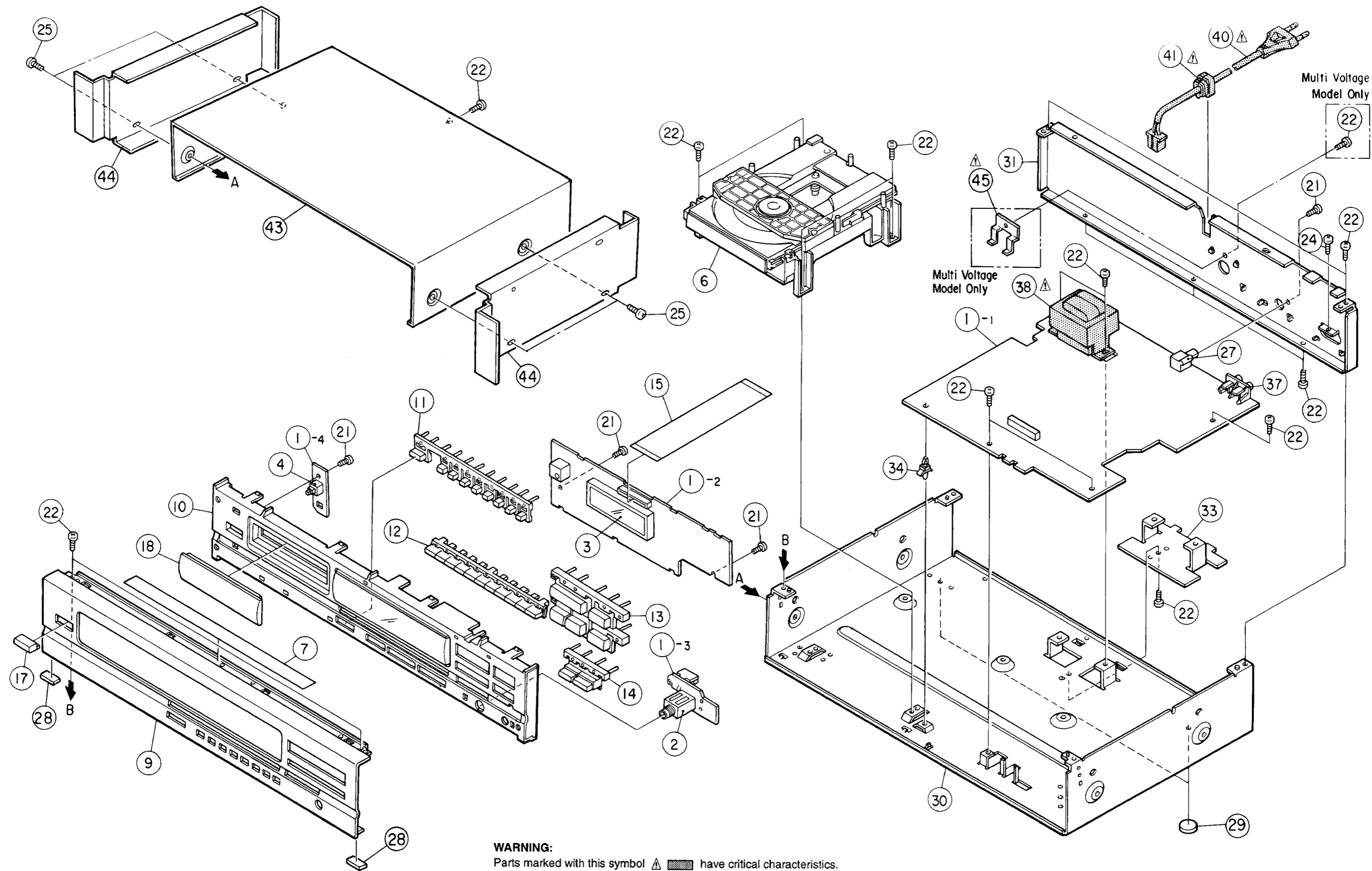

WARNING:
 Parts marked with this symbol  have critical characteristics.
 Use ONLY replacement parts recommended by the manufacturer.

EXPLODED VIEW OF FG-70 MECHANISM UNIT

PARTS LIST OF FG-70 MECHANISM UNIT

Ref. No.	Part .No	Part Name	Remarks
2	9KA 90H0 06	FS FIXING SCREW	
3	9KA 90H0 05	FEED SHAFT	
7	9KA 80G0 17	DRIVE GEAR (A)	
8	9KA 80G0 18	DRIVE GEAR (B)	
9	499 0191 009	LASER P.U	KSS-240A
12	9KS 01W1 47	LEAF SWITCH	
13	9KA 85P0 09	MOTOR P.W.B.	
15	009 0051 001	12P FFC CABLE	
16	443 1093 006	FFC BUSH	
17	9KA 82G2 53	S5B-PH CONNECTOR BASE	
18	9KM 20S0 04	2x4 SCREW	
19	9KA 85G0 26	MECHA.PLATE(FG70)	
20	9KA 85G0 20	MECHA.FRAME(FG70)	
21	9KA 85G0 21	CD TRAY(FG70)	
22	9KA 85G0 04	CLAMPER FRAME	
23	9KA 85G0 22	UD PLATE GEAR(FG70)	
24	9KA 85G0 06	CLAMPER (F)	
25	9KA 85G0 07	RELAY GEAR(A)	
26	9KA 85G0 08	RELAY GEAR(B)	
27	9KA 85G0 09	RELAY GEAR(C)	
28	9KA 85G0 10	GEAR BELT(F)	
29	9KA 85G0 30	DAMPER(FG40)	
30	9KA 85P0 01	CLAMPER PLATE (F)	
31	9KA 85H0 01	SCREW(F)	
34	9KA 82G0 57	MAGNET	
35	9KA 91H0 02	3x8 (W-10)SCREW	
36	9KB 30B0 08	3x8 BAIND SCREW	
37	9KM 26B0 04	2.6x4 BAIND SCREW	
39	9KA 82G3 08	S5B-PH(REL)	
40	9KA 85G0 27	CNW2(FG70)	
41	9KS 01W1 48	OP/CL SWITCH(SSS12)	
42	9KA 85S0 01	SPRING (A)	
43	9KA 85S0 02	SPRING (B)	
44	9KA 85S0 03	SPRING (C)	
45	9KA 85G0 33	GEAR GUIDE	
46	9KA 85G0 36	TRAY STOPPER	
47	9KB 20B0 05	2x5 BAIND (B)	
48	9KS 21W6 04	STW2.1x6x0.4	
50	9KA 85S0 05	HOLD SPRING	
60	9KA 85A0 07	SPINDLE MOTOR ASS'y	
61	9KA 85A0 08	FEED MOTOR ASS'y	
62	9KA 85A0 06	LOADING MOTOR ASS'y	
62-1		MOTOR P.W.B.	

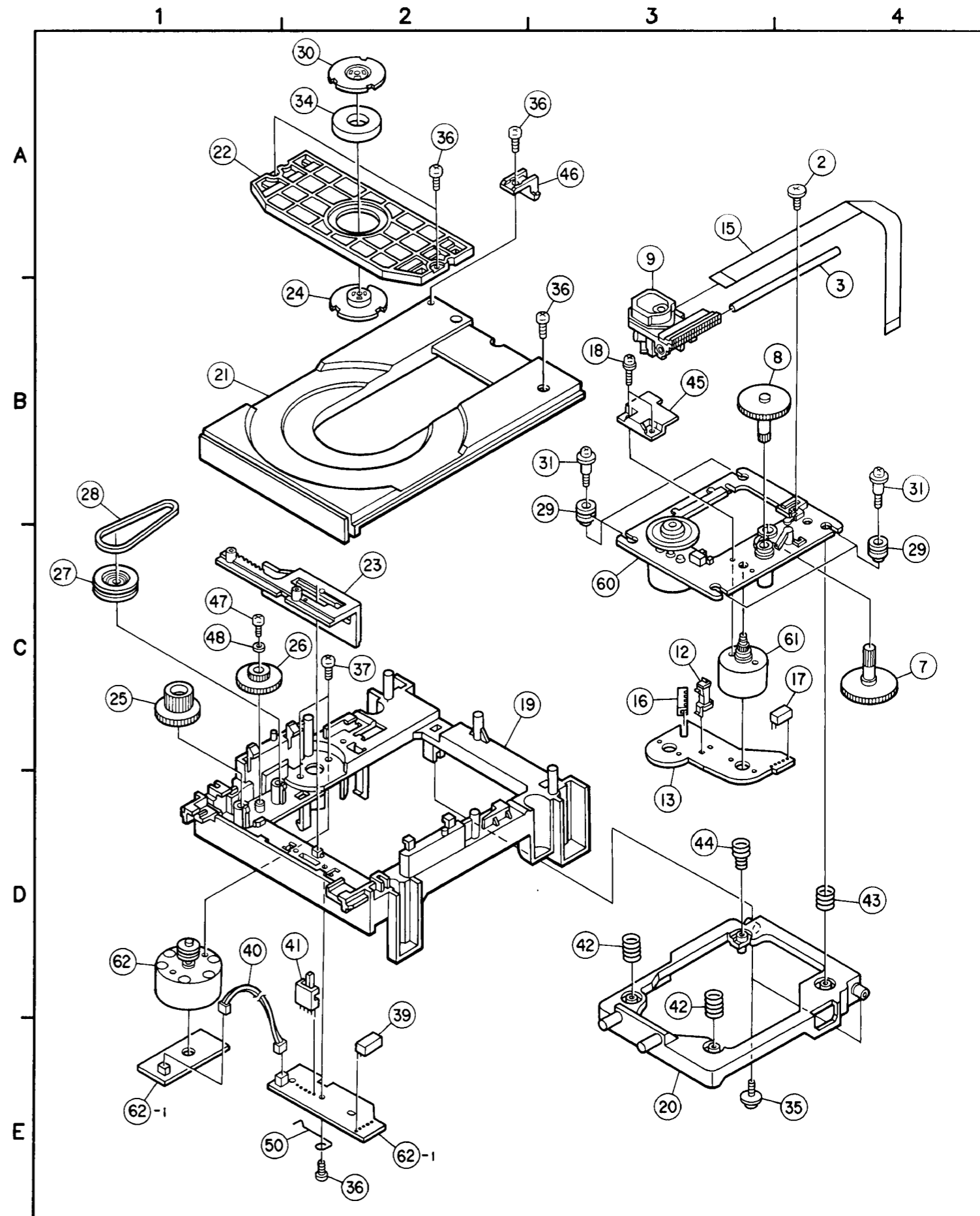

P.W.BOARD

1 2 3 4 5 6 7 8

3U-2599 MAIN UNIT

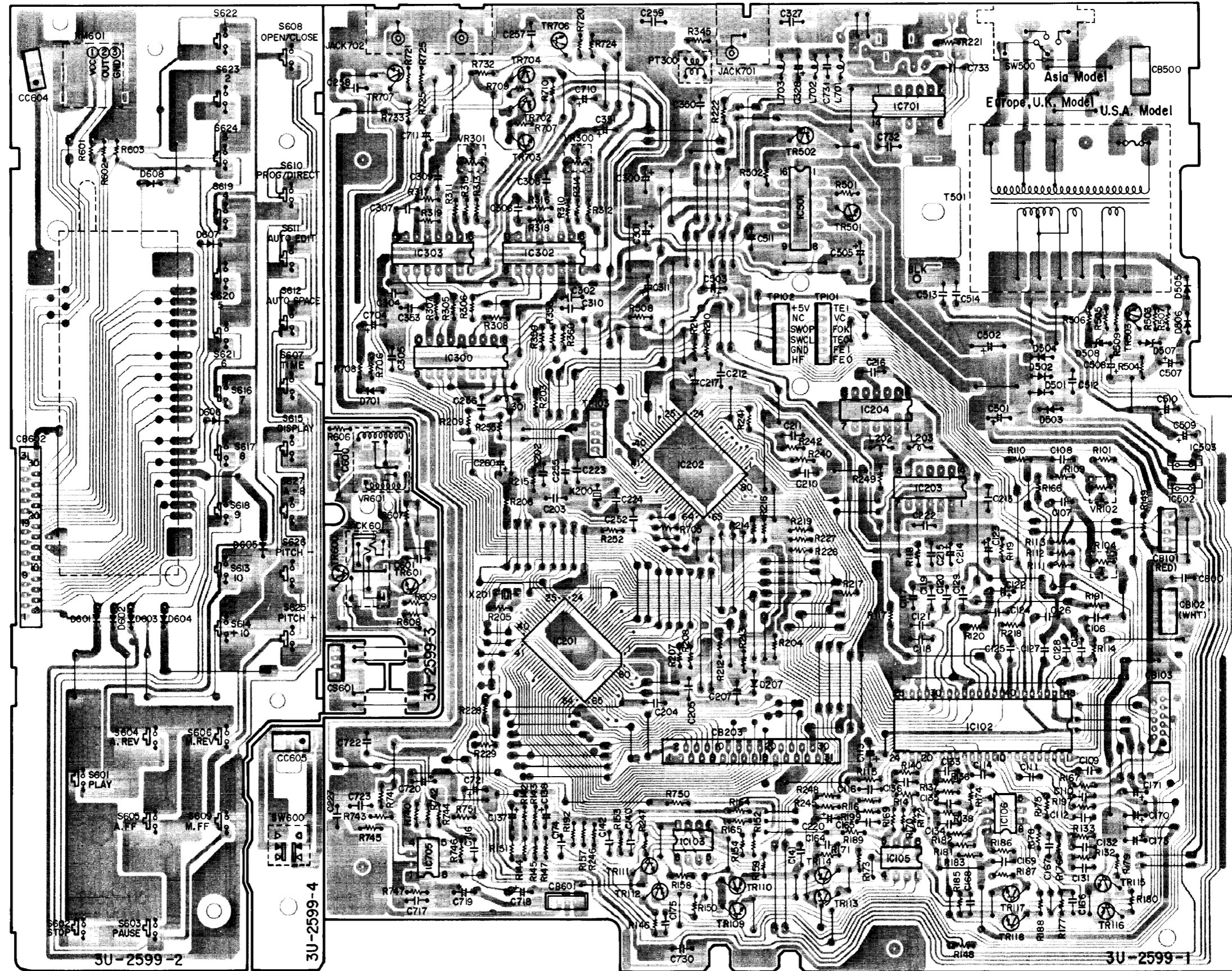

A
B
C
D
E

WIRING DIAGRAM

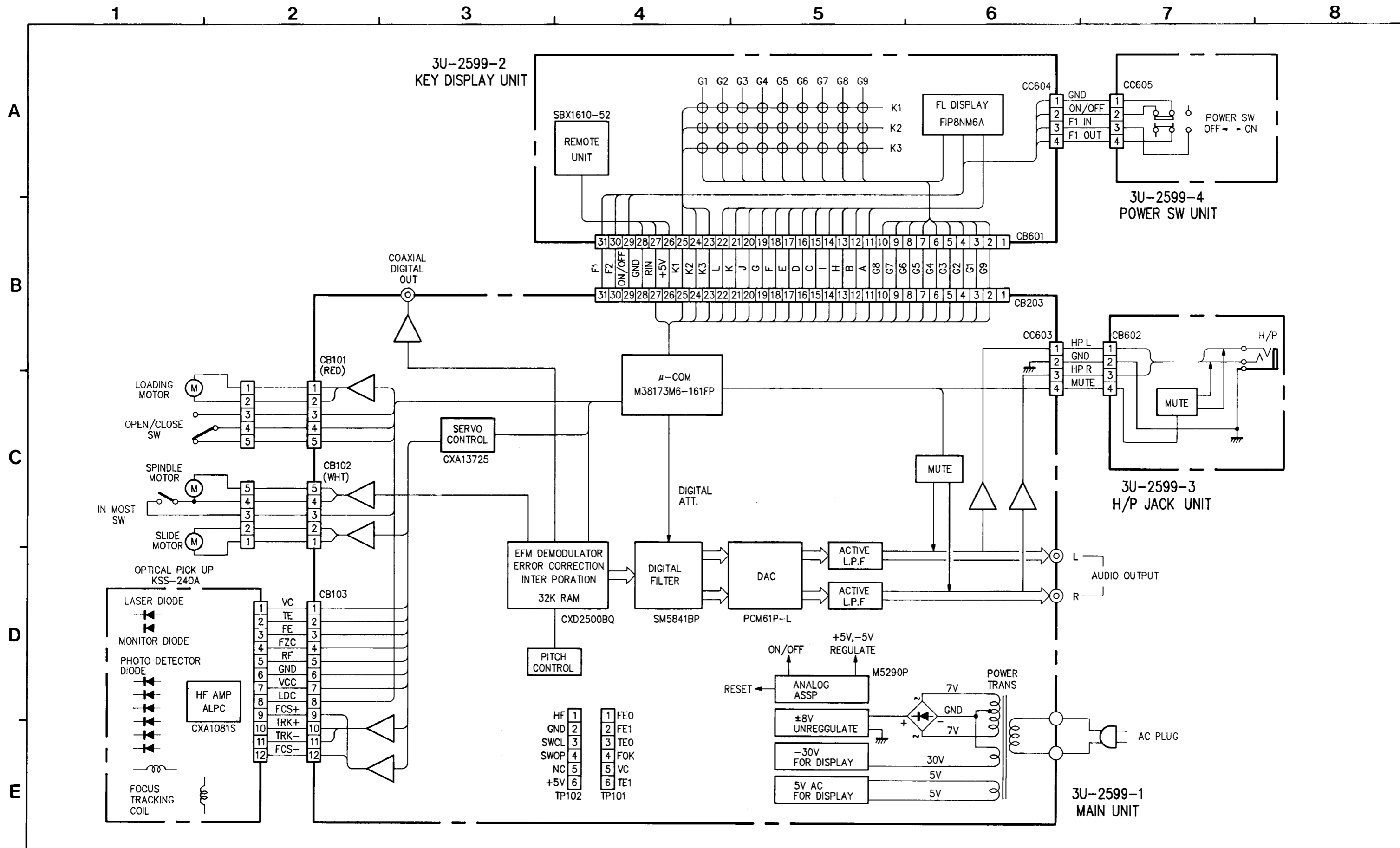

SCHEMATIC DIAGRAM

11 10 9 8 7 6 5 4 3 2 1

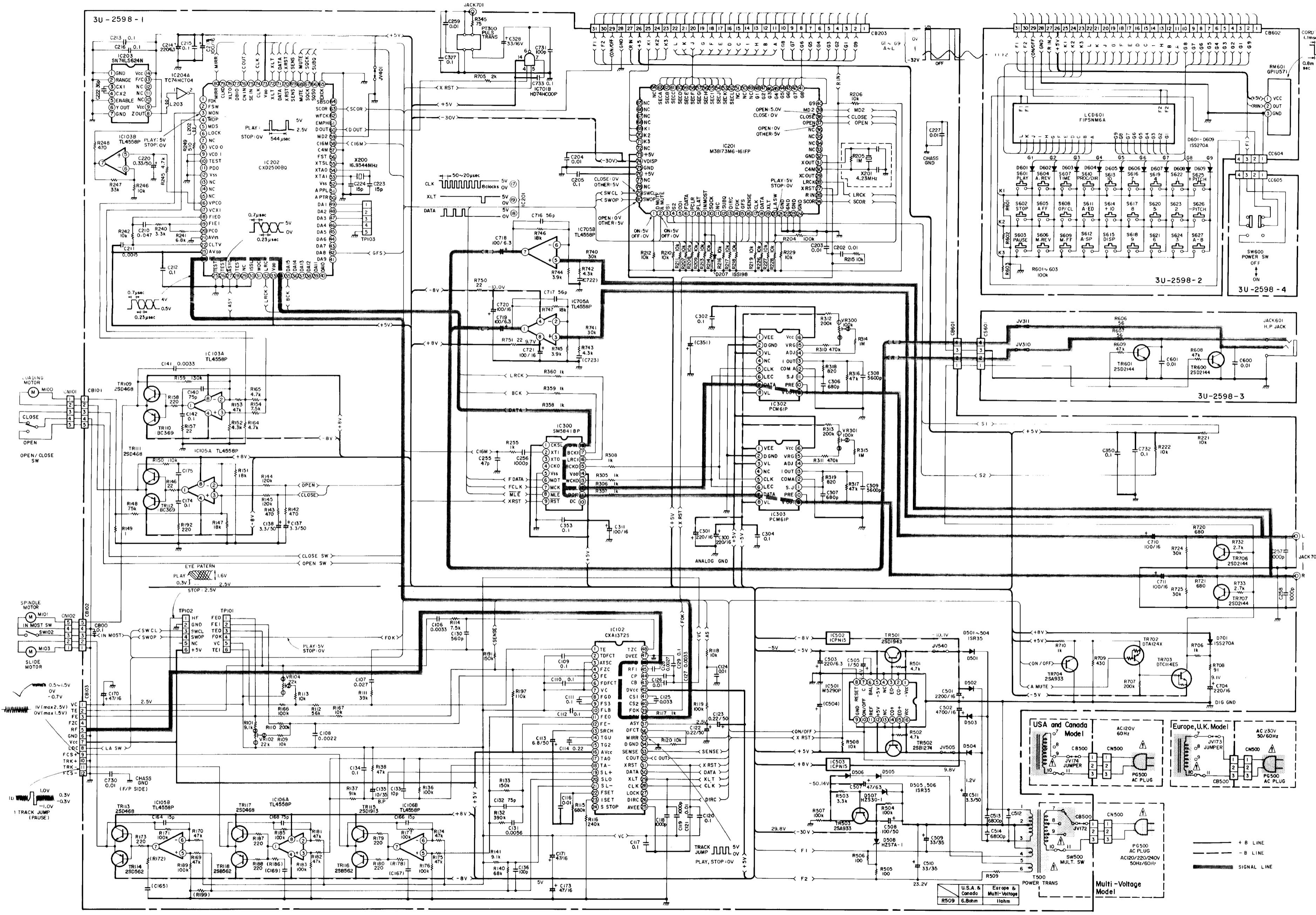

WARNING:
Parts marked with this symbol have critical characteristics.
Use ONLY replacement parts recommended by the manufacturer.

CAUTION:
Before returning the unit to the customer, make sure you make either (1) a leakage current check or (2) a line to chassis resistance check. If the leakage current exceeds 0.5 milliamperes, or if the resistance from chassis to either side of the power cord is less than 240 kohms, the unit is defective.

WARNING:
DO NOT return the unit to the customer until the problem is located and corrected.

NOTES
ALL RESISTANCE VALUES IN OHM. K=1,000 OHM, M=1,000,000 OHM
ALL CAPACITANCE VALUES IN MICRO FARAD. P-MICRO-MICRO FARAD
EACH VOLTAGE AND CURRENT ARE MEASURED AT NO SIGNAL INPUT CONDITION.
CIRCUIT AND PARTS ARE SUBJECT TO CHANGE WITHOUT PRIOR NOTICE.

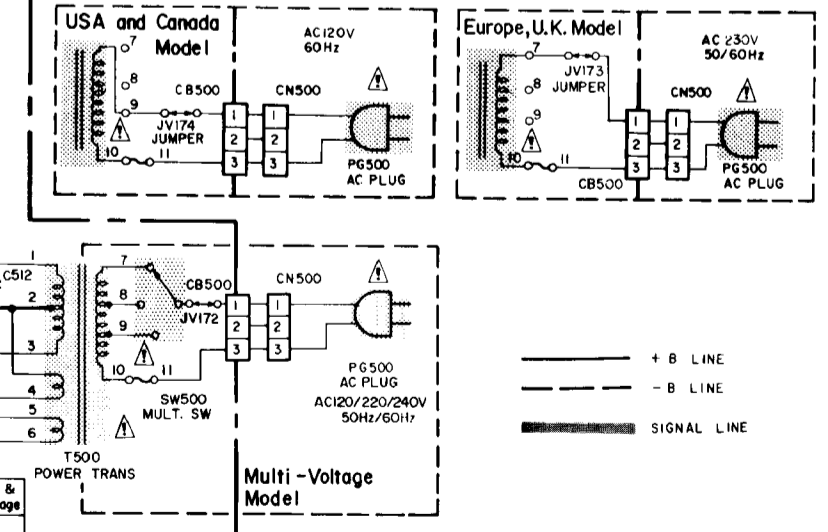

A
B
C
D
E
F
G
H

SEMICONDUCTORS

● IC's

TL4558P
:RC4558P

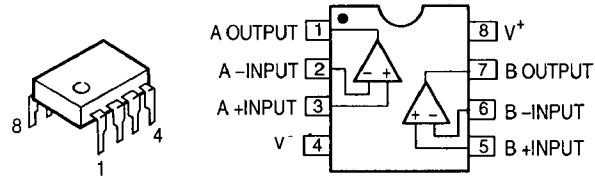

SM5841BP

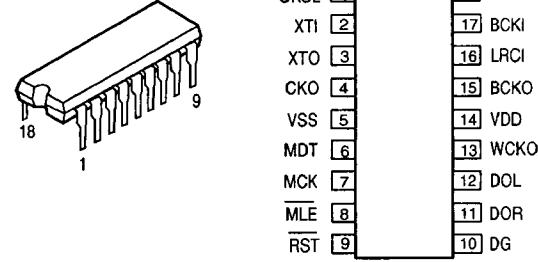

M5290P
PCM61P-L

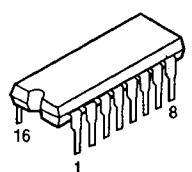

M5290P

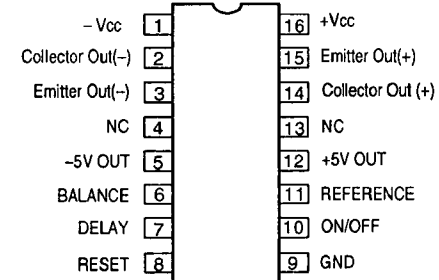

PCM61P-L

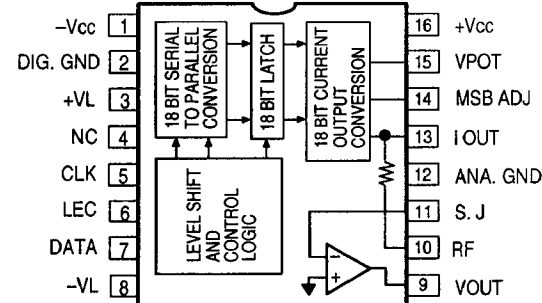

CXA1372S

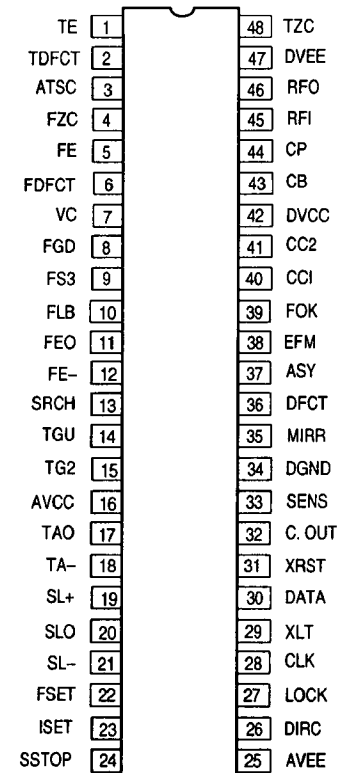
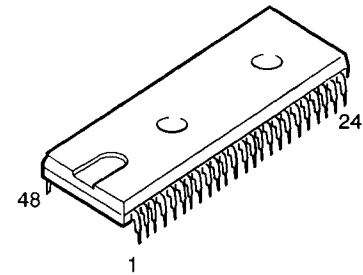

CXD2500BQ
M38173M6-161FP

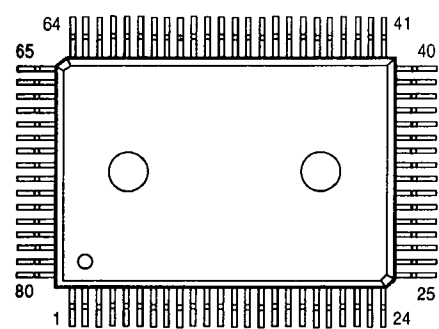

● IC PROTECTOR

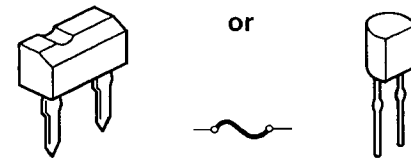

● IC DIODE

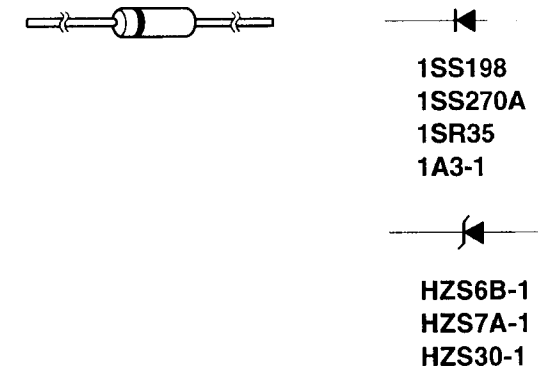

● TRANSISTOR

2SD1913
2SB1274
2SD1762
2SB1185

2SA933(Q)
2SD2144
:C557A/B

2SB562
2SD468(C)
:BC369
:BC368

DTC114ES(10K)
DTA124XS(22K-47K)

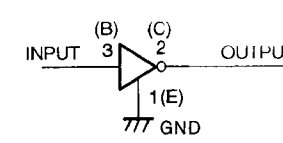
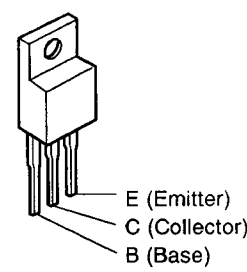

DENON

NIPPON COLUMBIA CO., LTD.

14-14, AKASAKA 4-CHOME, MINATO-KU, TOKYO 107-11, JAPAN

Telephone: 03 (3584) 8111

Cable: NIPPON COLUMBIA TOKYO Telex: JAPANOLA J22591