

3. Outline of the system

Directly and indirectly controls various Indicator, Side mirror and Relay control related to existing BCM function, controls start of vehicle when authentication of RKE key is successful, and performs warning and notation processing of data received from TPS sensor.

3.1. IBU NSMK

BCM function is a function for user convenience / warning, and it can directly or indirectly control various indicators, sensor power, hot wire and relay control through communication or switch input. It also performs Immobilizer function.

- Terminal control function: IGN1, IGN2, ACC power control
- Immobilizer function: Perform function for RKE Key authentication
- Head lamp washer relay control function - Optional function
- Indicator control function
- Auto light control function
- Puddle & Pocket Lamp control function
- Solenoid control function (ATM)
- PAS power control function
- LIN communication
- Chassis CAN communication (500kbps)
- Body CAN communication (500kbps)

3.2 Transponder Antenna:

Built in the Start Stop Button to communicate with the transponder by a base station and using wireless communication :(134.2kHz)

3.3 Installation in vehicle

The NSMK ECU is installed inside the vehicle.

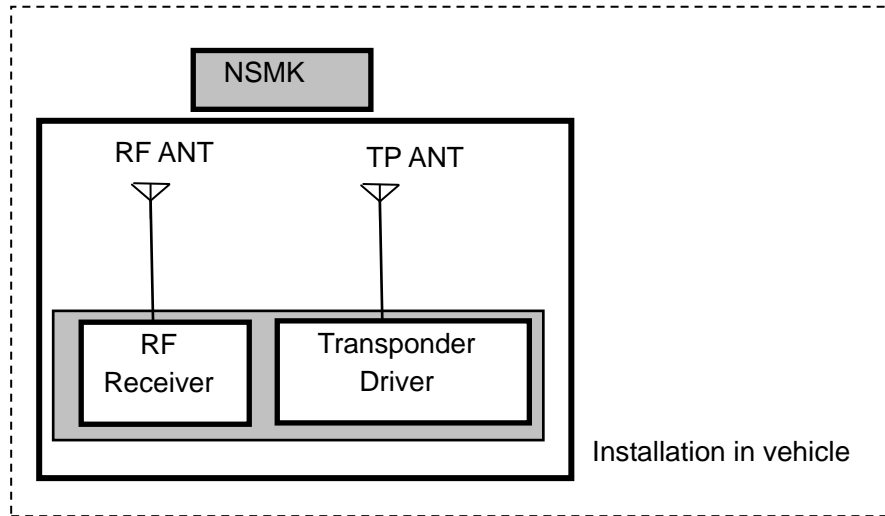

Fig. Outline of the System

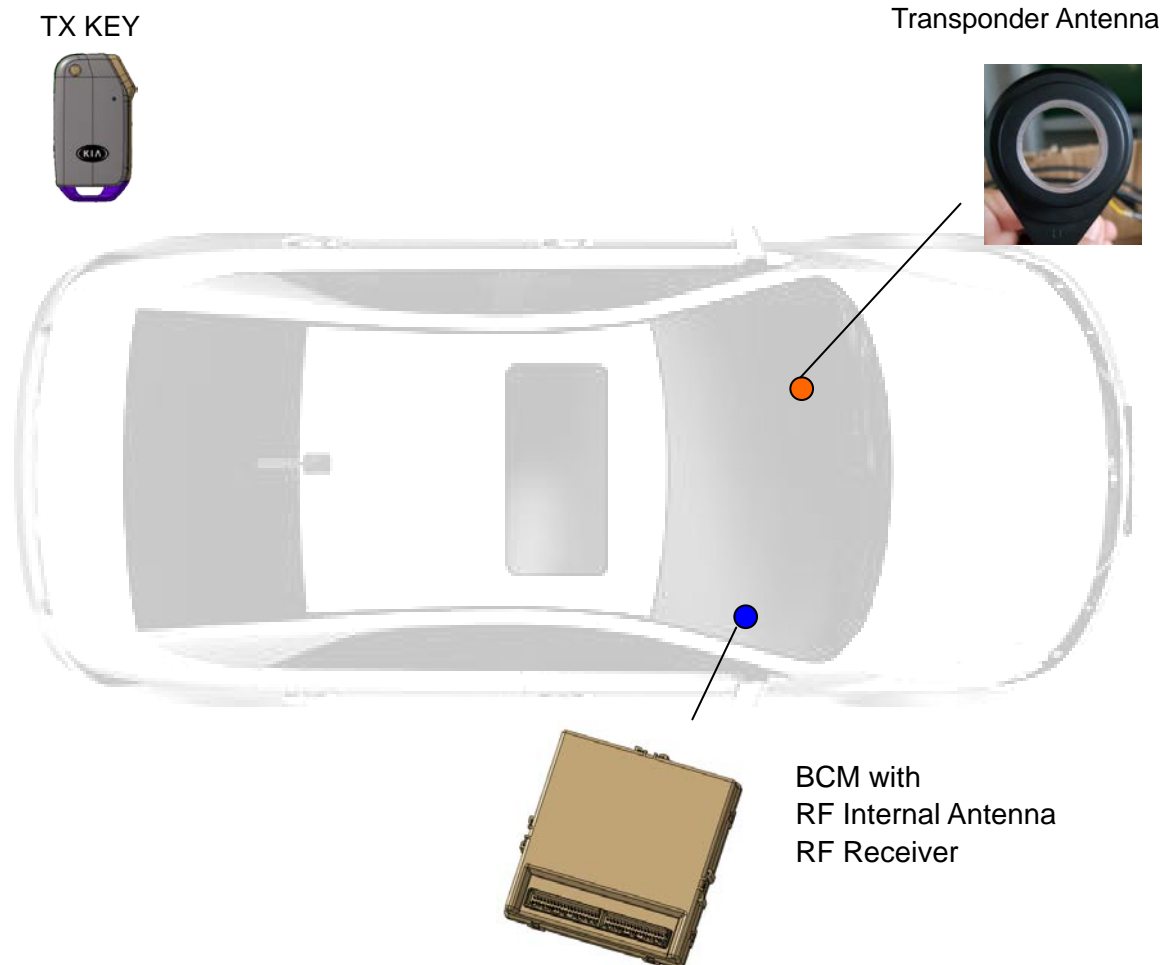

Fig. Installation of the System

FCC Warning

This equipment has been tested and found to comply with the limits for a Class B digital device, pursuant to part 15 of the FCC Rules. These limits are designed to provide reasonable protection against harmful interference in a residential installation. This equipment generates, uses and can radiate radio frequency energy and, if not installed and used in accordance with the instructions, may cause harmful interference to radio communications. However, there is no guarantee that interference will not occur in a particular installation. If this equipment does cause harmful interference to radio or television reception, which can be determined by turning the equipment off and on, the user is encouraged to try to correct the interference by one or more of the following measures:

- Reorient or relocate the receiving antenna.
- Increase the separation between the equipment and receiver.
- Connect the equipment into an outlet on a circuit different from that to which the receiver is connected.
- Consult the dealer or an experienced radio/TV technician for help.

Caution: Any changes or modifications to this device not explicitly approved by manufacturer could void your authority to operate this equipment.

This device complies with part 15 of the FCC Rules. Operation is subject to the following two conditions:

(1) This device may not cause harmful interference, and (2) this device must accept any interference received, including interference that may cause undesired operation.

IC Warning

"This device complies with Industry Canada licence-exempt RSS standard(s)."

Operation is subject to the following conditions: (1) this device may not cause interference, and (2) this device must accept any interference, including interference that may cause undesired operation of the device.

Le présent appareil est conforme aux CNR d'Industrie Canada applicables aux appareils radio exempts de licence. L'exploitation est autorisée aux deux conditions suivantes : (1) l'appareil ne doit pas provoquer de brouillage, et (2) l'appareil doit accepter tout brouillage radioélectrique subi, même si le brouillage est susceptible d'en compromettre le fonctionnement.