Technical Specification

DESKO PENTA Scanner®



PENTA Scanner®

DESKO GmbH
Gottlieb-Keim-Str. 56
95448 Bayreuth
GERMANY

Phone: +49 (0)921/79279-0
Fax: +49 (0)921/79279-14
E-mail: info@desko.com
Web: www.desko.com

Technical Support:
E-mail: support@desko.com | Online: www.desko.com/support | Phone: +49 (0) 921 79279-69

Table of Contents

DESKO Official Explanation of Abbreviations	3
1 Security Advice, Handling Rules & Package Content	4
1.1 Security Advice	4
1.2 Handling the DESKO PENTA Scanner	4
1.3 Package Content	4
2 Introduction	5
3 Features	6
3.1 Key Features of the DESKO PENTA Scanner	6
3.1.1 OCR Recognition	6
3.1.2 ID Document Image Scanning	6
3.1.3 Status LEDs	7
3.1.4 Buzzer	7
3.1.5 PERLUCOR® Security Glass	7
3.1.6 SDK Features	7
3.2 Optional Features	7
3.2.1 Barcode Recognition	7
3.2.2 RFID & NFC Reading	8
3.2.3 MSR Reading	8
3.2.4 Integrated Chip Card Reader	8
4 Hardware Integration and Setup	9
4.1 Hardware Integration	9
4.2 Hardware Setup	10
5 Software Integration	11
5.1 Connecting via Page Scan API	11
5.2 Virtual Serial Connection	11
5.3 Version Control	11
6 Usage of the DESKO PENTA Scanner	11
7 Service	14
7.1 Clean Glass Window	14
7.2 Clean Housing	14
8 Service and Maintenance	14
9 Warranty	14
10 Support	15
11 Technical Overview	16
11.1 Technical Data	16
11.2 Dimensions	16
11.3 Features of the DESKO PENTA Scanner Family	17
11.4 Regulation Information	18
12 Appendix A – Device Mounting Options	19
12.1 Pole Mount	19
12.2 Base Mount	20
12.3 Wall Mount	20
13 Appendix B – Supplier's Declaration of Conformity	21

DESKO Official Explanation of Abbreviations

1D Code	Linear or one-dimensional Barcode
2D Code	Two-dimensional Barcode
API	Application Programming Interface
BAC	Basic Access Control
BC	Barcode
BCR	Barcode Reader
DLL	Dynamic Link Library
DPI	Dots Per Inch
DUKPT	Derived Unique Key per Transaction
ICAO	International Civil Aviation Organization
IP	Ingress Protection
IR	Infrared
ISO	International Organization for Standardization
LED	Light Emitting Diode
MRZ	Machine-Readable Zone
MSR	Magnetic Stripe Reader
NFC	Near Field Communication
OCR	Optical Character Recognition
OS	Operating System
PCB	Printed Circuit Board
QIG	Quick Installation Guide
RFID	Radio Frequency Identification
RS232	Serial Interface
RTC	Real-Time Clock
USB	Universal Serial Bus
SDK	Software Development Kit
UV	Ultraviolet Light
VCOM	Virtual COM Interface
VIS	Visible Light
VIZ	Visual Inspection Zone
WLAN	Wireless Local Area Network

1 Security Advice, Handling Rules & Package Content

1.1 Security Advice

- The DESKO PENTA Scanner family contains UV-A and IR light sources which are classified as CLASS 1M LED PRODUCT according to IEC 60825-1.



That means that the light sources radiate intense invisible UV-A from IR light during the scan process. Consequently, precautions must be taken to prevent looking directly at the UV-A and IR light. Note that UV-A is an optional light source and might not be installed in every unit.

- Make sure that there is an easily-accessible outlet in the vicinity, where the device is to be installed
- Do not open the housing of the device and do not modify the device in any way.
- The device contains a backup battery for a Real-Time Clock (RTC), which is not accessible without opening the housing. Battery replacement must only be undertaken by trained service staff.

Caution: Risk of explosion if battery is replaced by an incorrect type. Dispose of used batteries according to the instructions.

-  The crossed-out rubbish bin logo means that used electrical and electronic products shall not be mixed with unsorted municipal waste. For more information about recycling of this product, refer to the instructions of your country for the disposal of these products.

1.2 Handling the DESKO PENTA Scanner

The PENTA Scanner is designed to work in a rough environment and withstand light shocks. Nevertheless, the device contains a precision opto-mechanical part.

DESKO recommends to follow certain handling rules such as:

- Do not drop the device.
- Prevent the device from heavy vibrations.
- The device is not waterproof, prevent the device from getting wet.
- Prevent the device from heavy dust.
- Do not lift the PENTA Scanner by pulling on its cover or display.
- To avoid scratches prevent the glass surface from sharp objects.

1.3 Package Content

- PENTA Scanner
- Power supply (5 V DC), different country versions
- USB 2.0 cable
- Quick Installation Guide with the link and log-in data for the PENTA Scanner download area. Within the download area you will find all relevant documents for the PENTA Scanner and necessary tools and drivers.

2 Introduction

This guide describes the standard use of the PENTA Scanner. Detailed information on the respective configuration can be found in the Quick Installation Guide, which is shipped with the device.

Please contact support@desko.com or visit us online at www.desko.com/support should you have not received a Quick Installation Guide or need access to our download area.

The PENTA Scanner is a full-page scanner designed to be used in self-service and agent operated environments. As an intelligent device, it supports OCR, barcode and magnetic stripe reading (depending on hardware configuration) within the device itself. It therefore reduces the required performance on the host system itself.

Depending on the hardware configuration, the device supports reading of:

- Machine-readable zone of OCR documents according to ISO/IEC 7501-1, ICAO 9303 and ISO 18013 (e.g. ID cards, passports, visas and driver licenses)
- 1D and 2D barcode documents printed on paper or presented on displays e.g. smartphone
- RFID documents according to ISO 14443 (A/B), ISO 7816 (incl. US passport), ICAO 9303 as well as full NFC support
- Magnetic stripe documents according to ISO 7811/2-5
- Chip card documents according to ISO 7816 and EMV² 2000 level 1



Picture 2.1: Front view of PENTA Scanner



Picture 2.2: Back view of PENTA Scanner

Immediately after a valid document has been scanned, the data will be sent to the host via the USB or the RS232 interface. Standard configuration is USB host addressed by the DESKO Page Scan API. USB virtual COM is available upon request.

Should you not know the exact configuration of your device or should you need further information on the PENTA Scanner, please contact our sales team at sales@desko.com. Please always state the serial number of the device in your email.

3 Features

3.1 Key Features of the DESKO PENTA Scanner

The PENTA Scanner is a multi-document reader. It supports various document types like passport or boarding passes. The actual features are depending on the hardware configuration.

3.1.1 OCR Recognition

The integrated ICAO document reader is capable of reading and decoding OCR data with a read rate of at least 99% from the following documents:

- Passport data from machine readable passports and ID cards according to ISO/IEC 7501-1 and ICAO 9303
- Personal OCR encoded travel documents e.g. Visa, Crew Member Cards according to ICAO 9303

(Additional document types can be supported upon request.)

3.1.2 ID Document Image Scanning

The PENTA Scanner scans documents with three different light sources (VIS, IR, UV-A) and provides the images via API in jpeg, png and bmp format.

Description of the used light sources (all light sources are LED light sources):

Light source	Description	Color temp./ Wavelength
VIS	Visible light	6000 K
IR	Near infrared light	850 nm
UV-A (optional feature)	Near ultraviolet light	365 nm

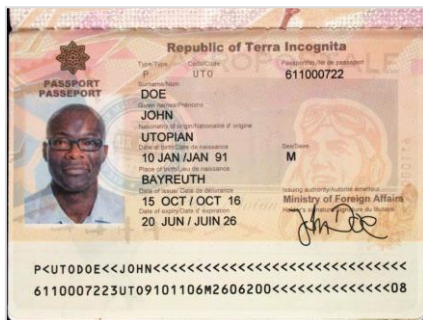

Visible Light

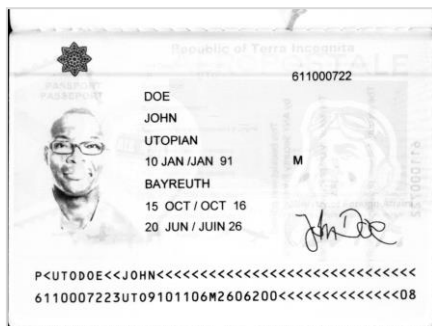

Near Infrared Light

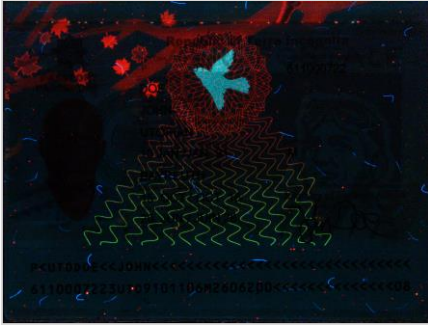

Near Ultra Violet Light
(optional feature)

3.1.3 Status LEDs

The PENTA Scanner has two integrated multicolor LEDs on the front. The right LED shows the power connection status of the device. The left LED is for custom use and can be controlled by the application using the device API. If configured for autonomous operation (BGR, CKI), the device can report the status of any read operation by controlling the LEDs itself. The respective behavior can be configured in the device.

3.1.4 Buzzer

An internal buzzer is available for audible user feedback. The buzzer volume and duration can be adjusted by the application using the device API. If configured for autonomous operation (BGR, CKI), the device can report the status of any read operation by controlling the buzzer itself. The respective behavior can be configured in the device.

3.1.5 PERLUCOR® Security Glass

All PENTA Scanners are by default equipped with PERLUCOR® security glass covering the scan area. Please refer to chapter 11.3 for more information.

3.1.6 SDK Features

When integrating the PENTA Scanner to your software via Page Scan API (please refer to chapter 5.1 for further information), you have access to all features of the PENTA Scanner.

Features include among others:

- ✓ Document cropping and rotating
- ✓ Thumbnail streaming
- ✓ Movement detection
- ✓ Document shape detection (ID1/ID2/ID3)
- ✓ B900 ink check
- ✓ UV dullness check

3.2 Optional Features

3.2.1 Barcode Recognition

The PENTA Scanner reads 1D and 2D barcode documents printed on paper or presented on displays e.g. mobile phone. Following barcode types are supported:

Linear barcodes (1D)	2D Barcodes
- Code 39	- Aztec
- Code 128	- DataMatrix
- GS1 128	- QR-Code
- EAN13 / JAN13	- PDF417
- Code Interleaved 2/5	
- Code Industrial 2/5	
- IATA 2/5	
- NEC 2/5	
- Code 2/5	

3.2.2 RFID & NFC Reading

The integrated RFID Module is a dual antenna design especially designed for passport reading. The RFID Module is able to read RFID documents according to ISO 14443 (A/B), ISO 7816 (incl. US passport), and ICAO 9303.

Note: RFID ePassport reading for BAC takes approx. 1.5 seconds, depending on the PC system and application. Generally, the type of ePassport/e-ID can also influence RFID reading performance. This is due to different chip sets and chip OS in various ePassport/e-ID document types. RFID ePassport reading speed may therefore vary from document to document.

3.2.3 MSR Reading

The integrated up to 3-track bidirectional magnetic stripe reader is able to read all magnetic stripe data encoded in equivalence to ISO 7811/2-5.

3.2.4 Integrated Chip Card Reader

The PENTA Scanner Chip Card Reader is compliant to ISO 7816 and EMV² 2000 level 1 and designed for reading synchronous and asynchronous chip cards with the following standards:

Standards	Protocols
ISO 7816 & EMV ² 2000 Level 1	T=0, T=1 2-wire: SLE 4432/42 (S=10), 3-wire: SLE 4418/28 (S=9), I ² C (S=8)

4 Hardware Integration and Setup

To use the PENTA Scanner, it needs to be connected to the power supply and the according host interface which is usually the USB port driven by the DESKO Page Scan API (see chapter 5.1 Connecting via Page Scan API).

4.1 Hardware Integration

The DESKO PENTA Scanner has the following connectors, indicated in the picture below:



1	Power Switch	ON / OFF
2	Power Connector	+ 5 V DC
3	USB Connector	USB 2.0 Full-Speed
4	Kensington Lock	optional (not used)

4.2 Hardware Setup

Step 1 – Power Connection

Connect the PENTA Scanner to the power plug (orange box). Only use the provided power supply!



Step 2 – Signal Connection

Connect the PENTA Scanner via the provided USB cable with your PC (green box).



Step 3 – Turning on the PENTA Scanner

After connecting the PENTA Scanner, turn the device on by switching the power switch (green box).



5 Software Integration

Software integration of the PENTA Scanner is done via a host connection. Usually, this is established by the DESKO Page Scan API connected via the USB host port.

All information about software, driver and SDK can be found in the DESKO download area. The link and login data for the download area can be found in the Quick Installation Guide, which was shipped with the device. Should you have any questions, please do not hesitate to contact support@desko.com or visit us online at www.desko.com/support.

5.1 Connecting via Page Scan API

To get access to all features of the PENTA Scanner, it needs to be connected via the USB host interface and addressed via the DESKO Page Scan API. This API is included in the device SDK which provides drivers for Windows 7, 8, 8.1 and 10, 32 bit and 64 bit as well as libraries and sample applications for C/C++, Java and .Net.

5.2 Virtual Serial Connection

For using the PENTA Scanner connected via a virtual serial COM port, it is necessary to install the DESKO VCOM software package and connect the device via USB. For detailed information please refer to the “DESKO Virtual COM Software Installation Guide”. The file can be found after installation of the package in the Windows Menu via Start → Program → DESKO PENTA Scanner.

This software generates a virtual COM port on the system, which can be used as a standard COM port. As soon as the generated virtual COM port is used by an application, the PENTA Scanner is ready for operation. In this mode of operation, the OCR and BCR data will be sent to the generated virtual COM port. The protocol description is available upon request.

5.3 Version Control

For maintenance reasons, e.g. firmware updates, the device must be connected to USB. All required features are available via the DESKO PageScan API to integrate in the customer application or via a dedicated software package. This can be found on in the DESKO download area and contains all necessary drivers, tools and documentation to perform the following actions:

- Read out detailed information about firmware version and device configuration.
- Update firmware.
- Update device configuration.

NOTE: for further information please contact support@desko.com or visit us online at www.desko.com/support.

6 Usage of the DESKO PENTA Scanner

This section explains how to scan different kinds of documents with the PENTA Scanner. All possible features of the PENTA Scanner are explained below.

More detailed information can be found on the DESKO YouTube channel <https://www.youtube.com/user/Deskovideo>.



Scanning an ID3 size document (e.g. passport):

To scan an ID3 passport document, you have to place the passport flat on the scan window with the MRZ (machine-readable zone) facing downwards, and push it against the stop.

Scanning an ID1 document (e.g. ID card with three-line MRZ):

To scan an ID1 document, you have to place the document flat on the scan window with the MRZ (machine-readable zone) facing downwards. The card should be positioned in the middle of the scan window and be pushed against the stop.

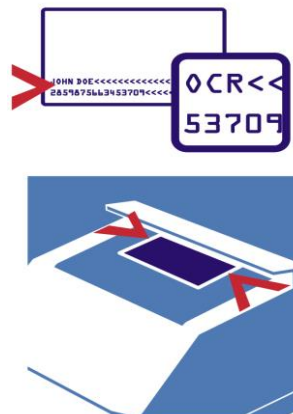

Scanning a barcode document (e.g. ticket):

To scan a barcode document, you have to place the document flat on the scan window with the barcode facing downwards. To obtain optimal read results, the barcode should be placed in the middle of the scan window.

Reading an RFID document (e.g. ePassport):

The PENTA Scanner is equipped with two RFID antennas. The two antennas are hidden mounted around the scan window and the sloped part of the housing. Therefore, it doesn't matter whether the RFID chip is integrated inside the front or rear cover of the passport.



Reading an NFC document (e.g. mobile ticket):

NFC devices such as smartphones with integrated NFC chip, can be placed near each of the two antennas in order to start a NFC read.

Reading an MSR document (e.g. frequent traveler card):

To read a magnetic stripe document, you have to pull it through the bidirectional swipe slot of the PENTA.

Please note that the magnetic stripe of the document has to face towards the user.

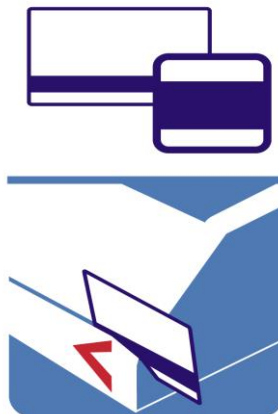

7 Service

If the scan window is dirty from fingerprints, stain or dust, it can slow down the scanning performance and affect the accuracy of scanning. We therefore recommend cleaning the scan window on a regular basis.

7.1 Clean Glass Window

1. Turn off the PENTA Scanner.
2. Clean the glass with a soft cloth or sponge slightly moistened with a nonabrasive glass cleaner.
3. Dry the glass with a chamois or cellulose sponge to prevent spotting.

7.2 Clean Housing

1. Turn off the PENTA Scanner.
2. Clean the housing with a soft cloth or sponge slightly moistened with a nonabrasive, solvent free cleaner.
3. Dry the housing with a chamois or cellulose sponge to prevent spotting.

8 Service and Maintenance

In general, DESKO products are maintenance free. However, should you require any technical assistance, contact our support team at support@desko.com or visit us online at www.desko.com/support.

For maintenance regarding firmware upgrade, it is required to install a dedicated DESKO software package. This can be obtained upon request and contains all necessary drivers, tools and documentation to perform the following actions:

- Display detailed information about firmware version and device configuration.
- Update firmware and device configuration.

Please contact our support team, should you require this specific DESKO software package.

9 Warranty

Please note that due to improper usage (see chapter 1.2 Handling the DESKO PENTA Scanner) or after opening the device, warranty cannot be claimed anymore. Warranty also excludes normal wear and tear.

10 Support

Please check if the PENTA Scanner is connected and, if needed, the software is installed properly. If this is the case and the device still does not work, please contact our DESKO support team:

Technical Support

E-mail: support@desko.com
Web: www.desko.com/support

Phone: +49 (0) 921 79279-69
(available during German office hours)

In order to give you an immediate and reliable support please always include the following information within your support inquiry:

- ✓ Name of the product
- ✓ Serial number of the product (*The serial number can be found on the back of the device. It is an eleven-digit number, always starting with 20, Example: 201546 00589*)
- ✓ Used firmware, configuration and software version
- ✓ Detailed issue description
- ✓ Corresponding logfiles (VCOM with log level 4: C:\hid2ser.log and C:\Windows\hid2ser.ini (see also VCOM manual). Device updater: C:\%userprofile%\AppData\Roaming\DESKO GmbH\DeviceUpdater)
- ✓ Contact details of the person responsible at your company

11 Technical Overview

11.1 Technical Data

Input Voltage:	5 V DC (max. tolerance ± 5 %)
Max. tolerance voltage:	5 V DC ± 5 %
Requirement for the external Power supply unit:	according to IEC60950 – 1 or PS2 classified IEC62368-1
Input Current:	2,5 A max
Storage Temperature:	-10 °C to +50 °C
Operating Temperature:	0 °C to +40 °C
Humidity:	20 % to 80 % (R.H. non-condensing)
Special conditions:	No direct sunlight on scan window
Reliability:	MTBF = 180.000 hours
RF / EMI Compliance: <i>Test report available upon request.</i>	CE and FCC

11.2 Dimensions

PENTA Scanner

Footprint: <i>Detailed dimensional drawing is available upon request.</i>	219.9 mm (8.7 inches) x 150 mm (5.9 inches) x 144.7 mm (5.7 inches) // 191.2 mm (7.5 inches) with touch display
Scan Window Size:	94 mm (3.7 inches) x 131 mm (5.2 inches)
Weight:	Approx. 1150 g (2.5 lb)

11.3 Features of the DESKO PENTA Scanner Family

OCR Recognition:	OCR reader according to ISO/IEC 7501-1, ISO 18013 and ICAO 9303
ID Document Image Scanning:	Scan documents with three different light sources (VIS = 5600 K, IR = 850 nm, UV-A = 365 nm) up to 500 dpi
Status LEDs:	1x power LED, 1x status multicolor LED
Buzzer:	Integrated buzzer, volume adjustable
PERLUCOR® Security Glass:	Scratch resistant to natural materials, optical grade bigger than 92% of relative transparency
Barcode Scanner:	1D and 2D barcode documents printed on paper or presented on displays e. g. smartphone
RFID & NFC:	RFID documents according to ISO 14443 (A/B), ISO 7816 (incl. US passport), ICAO 9303 as well as full NFC support
Data Output / Connectors:	1 x USB Host 2.0

11.4 Regulation Information

This device complies with FCC §15.105 (b):

NOTE: This equipment has been tested and found to comply with the limits for a Class A digital device, pursuant to part 15 of the FCC Rules. These limits are designed to provide reasonable protection against harmful interference when the equipment is operated in a commercial environment. This equipment generates, uses, and can radiate radio frequency energy and, if not installed and used in accordance with the instruction manual, may cause harmful interference to radio communications. Operation of this equipment in a residential area is likely to cause harmful interference in which case the user will be required to correct the interference at his own expense.

This device complies with Industry Canada license-exempt RSS standard(s). Operation is subject to the following two conditions:

(1) This device may not cause harmful interference, and (2) this device must accept any interference received, including interference that may cause undesired operation.

Le présent appareil est conforme aux CNR d'Industrie Canada applicables aux appareils radio exempts de licence. L'exploitation est autorisée aux deux conditions suivantes :

(1) l'appareil ne doit pas produire de brouillage, et (2) l'utilisateur de l'appareil doit accepter tout brouillage radioélectrique subi, même si le brouillage est susceptible d'en compromettre le fonctionnement.

CAUTION: Any changes or modifications not expressly approved by DESKO GmbH could void the user's authority to operate the equipment.

12 Appendix A – Device Mounting Options

The PENTA Scanner provides the option to be mounted in different ways. Therefore, the PENTA Scanner is equipped with four thread inserts M3 – depth 4 mm at the bottom side of the device, as indicated in the picture below:

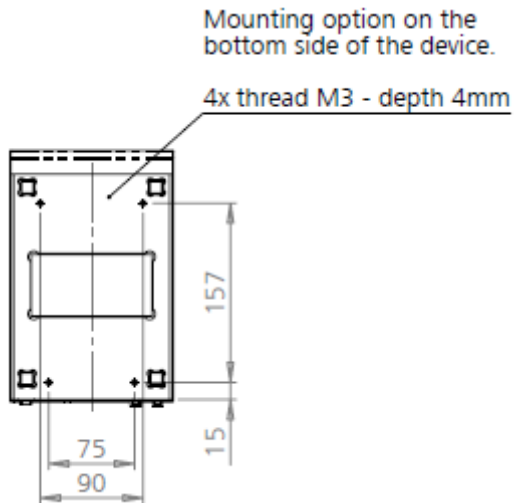

You can also purchase the following mounting kits. Each mounting kit also works with the optional available Battery adapter and Battery Pack. A detailed description for assembly is included in each mounting kit.

12.1 Pole Mount

Equipped with a battery adapter and battery pack, the Pole Mount is the best way to use the PENTA Scanner as a stand-alone device e.g. for boarding pass validation.



12.2 Base Mount

The Base Mount is designed to secure the PENTA Scanner on a flat surface like a table, counter or a podium.



12.3 Wall Mount

Without compromise, the Wall Mount is the best way to install the PENTA Scanner where space is rare.

Fastening the Wall Mount to a wall and fitting the PENTA Scanner on top will bring you the features of the scanner to every corner.



For further information concerning the mounting options, please contact our DESKO support team at support@desko.com or visit our website at www.desko.com/support.

13 Appendix B – Supplier's Declaration of Conformity

Unique Identifier: PENTA Scanner®

Party issuing Supplier's Declaration of Conformity

DESKO GmbH
Gottlieb-Keim-Str. 56
95448 Bayreuth
GERMANY

Phone: +49 (0)921/79279-0

Web: www.desko.com

Responsible Party – U.S. Contact Information

DESKO LC
1800 Pembroke Drive
Suite 300
Orlando FL 32810
United States

FCC Compliance Statement

This device complies with Part 15 of the FCC Rules. Operation is subject to the following two conditions: (1) This device may not cause harmful interference, and (2) this device must accept any interference received, including interference that may cause undesired operation.