

Szie: 105 x 148mm
125g铜版纸, 风琴折叠

105mm

RETRO SPEAKER



LE-PSPE

Safety information

Please read the safety instructions carefully before using the product for the first time and keep the instructions for future reference.

1. This product is not a toy. Keep it out of reach of children.
2. Warning: This product includes lithium ion batteries.
3. Keep product out of the reach of children and pets to avoid chewing and swallowing.
4. Product operating and storage temperature is from 32°F Celsius to 104°F. Under and over this temperature might affect the function.
5. Never open the product. Touching the inside electrics can cause electric shock. Repairs or service should only be performed by qualified personnel.
6. Do not expose to heat, water, moisture, direct sunlight!
7. Please protect your ears against loud volume. Loud volume can damage your ears and risk in hearing loss.
8. Bluetooth wireless technology operates within a range of about 10 m (30 feet). The maximum communication distance may vary depending on the presence of obstacles (people, metal objects, walls, etc.) or the electromagnetic environment.
9. Microwaves emitting from a Bluetooth device may affect the operation of electronic medical devices.
10. The unit is not waterproof. If water or foreign objects enter the unit, it may result in fire or electric shock. If water or a foreign object enters the unit, stop use immediately.
11. Only charge with supplied USB cable.
12. Do not use non original accessories together with the product as this can make the product functionality abnormal.

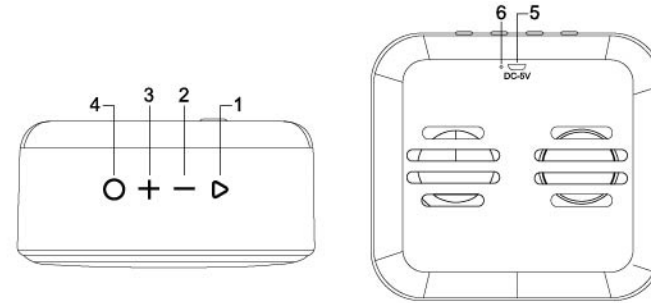

1. Play/Pause button/Power display/TWS mode
2. VOL - button/Backward button
3. VOL + button/Forward button
4. On/Off button/Switch animation mode button
5. Charging port

Power supply

1. Check that the unit is switched off.
2. Insert the small end of the micro USB cable (included) into the micro USB charging port (5) on the back of the unit.
3. Connect the other end of the micro USB cable into the USB port of your powered computer or USB type power adapter and connect it to a wall socket. The LED near the micro USB charging port lights up in red when the device is charging.
4. Once charging is completed, the LED light will turn off.
Note: Please note that the micro USB cable can only be used for battery charging and not for data transfer.
5. To turn the speaker on/off, Press and hold down button 4 on the top of the speaker. A signal will sound. To adjust the volume, press button 2 to decrease the volume and press button 3 to increase the volume.

MODES

- To switch mode, double-click on button 4.

NAVIGATE BETWEEN AUDIO TRACKS

- To pause playback, press button 1. To resume playback, press button 1 once again.
- To play the next track, press and hold down button 3.
- To play the previous track, press and hold down button 2.

BLUETOOTH PAIRING

1. Activate the Bluetooth function on the speaker and your audio player (smartphone, tablet...) and make sure it is in discoverable mode.
2. Confirm pairing or select the Bluetooth name "LE-PSPE" to connect your player to the speaker.
3. You can play an audio or video files. the speaker will emit a sound after it has connected successfully.
4. To stop connection with the speaker, press another mode on the top panel or a button on your audio player, one the connection has been stopped the LED indicator will flash.

CONNECT 2 SPEAKERS IN STEREO:

You can connect two A and B "LE-PSPE" speakers together to enjoy stereo sound (available only in Bluetooth mode):

1. Delete "LE-PSPE" from your audio player's Bluetooth history to connect your player to the speaker.
2. Enter Bluetooth mode on the 2 speakers simultaneously. Press button 1 on one of the speakers twice in a row to enter stereo mode.
3. Once the pairing is successful between the two speakers, an audible signal will sound.
4. Then connect your audio player (smartphone, tablet, etc.) to one of the two speakers.

LIGHT EFFECTS

Press and hold down button 1 for 5 seconds to turn the light effects on/off. To switch animation, press button 4.

CAUTION: Too high volume can damage your hearing. For this reason, please turn the volume down.

SPECIFICATIONS:

Input Power	USB DC 5V 1A
Bluetooth Version	V5.1
Transmission Distance	10M
Battery Lithium Battery	3.7V, 2000mAh
Play Time	2-3 Hours
Speaker Output	5W ϕ 52mm
Bluetooth Frequency Rang	2402-2480MHz
Transmission Power	2.721dBm
Material	ABS
Size	128*128*63MM
FCC ID	2AANZPSPE
BT ID	D059694

FCC STATEMENT

This device complies with part 15 of the FCC Rules. Operation is subject to the following two conditions: (1) This device may not cause harmful interference, and (2) this device must accept any interference received, including interference that may cause undesired operation.

FCC INSTRUCTIONS FOR A CLASS B DIGITAL DEVICE OR PERIPHERAL

Note: This equipment has been tested and found to comply with the limits for a Class B digital device, pursuant to part 15 of the FCC Rules. These limits are designed to provide reasonable protection against harmful interference in a residential installation. This equipment generates, uses and can radiate radio frequency energy and, if not installed and used in accordance with the instructions, may cause harmful interference to radio communications. However, there is no guarantee that interference will not occur in a particular installation. If this equipment does cause harmful interference to radio or television reception, which can be determined by turning the equipment off and on, the user is

encouraged to try to correct the interference by one or more of the following measures:

- Reorient or relocate the receiving antenna.
- Increase the separation between the equipment and receiver.
- Connect the equipment into an outlet on a circuit different from that to which the receiver is connected.
- Consult the dealer or an experienced radio/TV technician for help.

Changes or modifications not expressly approved by the party responsible for compliance could void the user's authority to operate the equipment.

DGL Group, Ltd.
2045 Lincoln Highway, 3rd Floor, Edison, NJ, 08817, USA

www.dglusa.com