

DRTECH EVS 3643 System
Safety and Regulatory Information
with User's Manual



DRTECH
(주)디알텍

Thank you for purchasing the DRTECH Radiography EVS 3643 (hereinafter this Product). This User's Manual explains how to use the detector, x-ray interface unit, and other peripheral equipment. Before using this product, be sure to read this manual thoroughly in order to utilize it more effectively. Also, read the Operation Manual for EVS Calibration and configuration Software (hereinafter ECal1).

Important information on usage and management of equipment

1. Only a physician or legally certified operator should use this product.
2. The equipment should be maintained in a safe and operable condition by maintenance personal.
3. Use only computers and image display monitors complying with IEC 60601-1 or IEC 60950-1 and under asystem configuration complying with IEC 60601-1-1. For details, consult your sales representative or local DRTECH dealer.
4. Use only the dedicated cables. Do not use any cables other than those supplied with this product.

Disclaimer

1. In no event shall DRTECH be liable for any damage or loss arising from fire, earthquake, any action or accident by a third party, any intentional negligent action by users, any trial usage, or other usage under abnormal conditions.
2. Roentgenography, image processing, image reading, and image data storage must be performed in accordance with the laws of the country or region in which the product is being used. The user is responsible for manufacturing the privacy of image data.
3. In no event shall DRTECH be liable for personal physical harm or property damage that is sustained when the instructions are not followed or the product is misused.
4. It is the responsibility of the attending physicians to provide medical care services. DRTECH will not be liable for faulty diagnoses.
5. In no event shall DRTECH be liable for direct or indirect consequential damages arising from the use or unavailability of this product. DRTECH shall not be liable for loss of image data for any reason.
6. In no event shall DRTECH be liable for any damage arising from moving, alteration, inspection or repair by a person other than authorized service engineers.
7. Specifications, composition, and appearance of this product may change without prior notice.

To Customers..... 2

Contents..... 3

Conventions..... 5

1. Safety information.....**6**

 1-1. Safety precautions.....6

 1-2. Notes for using the equipment.....10

2. Introduction.....**12**

 2-1. Features.....12

 2-2. Intended use.....12

 2-3. System configuration.....13

3. Product description.....**14**

 3-1. Product components.....15

 3-2. X-ray imaging condition.....16

4. Parts name and functions.....**17**

 4-1. Detector specification.....17

 4-2. Detector component.....18

 4-3. Detector dimension.....19

 4-4. SSU (System synchronization unit).....20

 4-5. Wireless access point.....20

5. Operating procedure.....**22**

 5-1. Preparing to use the detector.....23

 5-2. Operating the detector.....23

 5-3. Ending use of the detector.....27

 5-4. Detector status list.....27

6. Extension facility.....	28
6-1. Using the wireless detector with other EXPRIMER series detectors in a same system ...	28
6-2. Sharing the wireless detector among different systems.....	29
6-3. AED mode.....	30
6-4. Wiring connections.....	31
7. How to Install.....	32
8. Troubleshooting.....	89
9. Maintenance	90
10. Specification.....	91
10-1. Main specifications.....	91
EVS 3643 Detector.....	91
SSU(system synchronization unit).....	92
10-2. Characteristics.....	93
11. Regulatory information.....	94
11-1. Medical equipment safety standards.....	94
■ Medical equipment classification.....	94
■ Product safety standards.....	94
11-2. Radio frequency (RF) compliance information.....	95
Declaration conformity.....	95
11-3. Labels and markings on the equipment.....	99
■ Detector.....	99
■ Other components of the EVS 3643 system.....	101
11-4. Guidance and manufacturer's declaration for EMC.....	103
Electromagnetic emissions.....	103
Electromagnetic immunity.....	103
Electromagnetic separation distances.....	103
12. Warranty	106

Safety notices

The following safety notices are used to emphasize certain safety instructions. Follow the safety instructions in this user's manual along with warning and cautions symbols. Ignoring such warnings or cautions while handling the product may result in serious injury or accident. It is important for you to read and understand the contents of this user's manual before attempting to use the product.



This notice is used to identify conditions under which improper use of the product may cause death or serious personal injury.

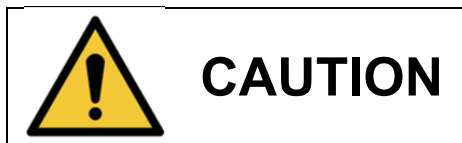

This notice is used to identify conditions under which improper use of the product may cause minor personal injury.



This notice is used to identify conditions under which improper use of the product may cause property damage.



This is used to indicate a prohibited operation.



This is used to indicate an action that must be performed.



This is used to indicate important operations and restrictions. Be sure to read this notice to prevent property damage or malfunction.

This is used to indicate operations for reference and complementary information. Users are recommended to read this notice.

1-1. Safety precautions

Follow these safeguards and properly use the equipment to prevent injury and damage to any equipment/data.



WARNING

Installation and environment of use



Prohibited

- **Do not use or store the equipment near flammable chemical such as alcohol, thinner, benzene, etc.**
If chemicals are spilled or evaporate, it may result in fire or electric shock through contact with electric parts inside the equipment. Also, some disinfectants are flammable. Be sure to take care when using them.
- **Do not connect the equipment with anything other than specified.**
Doing so may result in fire or electric shock.

Power supply



Prohibited

- **Do not use operate the equipment using any type of power supply other than the one indicated on the rating label.**
Otherwise, it may result in fire or electric shock.
- **Do not handle the equipment with wet hands.**
You may experience an electric shock that could result in death or serious injury.
- **Do not place heavy object such as medical equipment on cables and cords, or do not pull, bend, bundle, or step on them to prevent their sheath from being damaged, and do not alter them neither.**
Doing so may damage the cords which could result in fire or electric shock.
- **Do not supply power to more than one of equipment using the same AC outlet.**
Doing so may result in fire or electric shock.
- **Do not turn on the system power when condensation has formed on the equipment.**
Doing so may result in fire or electric shock.
- **Do not connect a multiple portable socket-outlet or extension cord to the system.**
Doing so may result in fire or electric shock.



- **Securely plug the power cord into the AC outlet.**
If contact failure occurs, or if dust or metal objects come into contact with the exposed metal prong of the plug, fire or electric shock may result.
- **Be sure to turn OFF the power to each of equipment before connecting or disconnecting the cords.**
Otherwise, you may get an electric sock that could result in death or serious injury.
- **Be sure to hold the plug or connector to disconnect the cord.**
If you pull the cord, the core wire may be damaged, resulting in fire or electric shock.



WARNING

Handling

The system, in whole or in part, cannot be modified in any way without written approval from DRTECH.



Prohibited

- **No modification of this equipment is allowed**
- **Never disassemble or modify the equipment.**
Doing so may result in fire or electric shock. Also, since the equipment incorporates parts that may cause electric shock as well as other hazardous parts, touching them may cause death or serious injury.
- **Do not place anything on top of the equipment.**
The object may fall and cause an injury. Also if metal objects such as needles or clips fall into the equipment, or if liquid is spilled, it may result in fire or electric shock.
- **Do not hit or drop the equipment.**
The equipment may be damaged if it receives a strong jolt, which may result in fire or electric shock if the equipment is used without being repaired.



- **Have the patient take a fixed posture and do not let patient touch parts unnecessarily.**
If the patient touched connectors or switches, it may result in electric shock or malfunction of the equipment.

When a problem occurs



- **Should any of the following occur, immediately turn OFF the power to each piece of equipment, unplug the power cord from the AC outlet, and contact your sales representative or local DRTECH dealer:**
When there is smoke, an odd smell or abnormal sound
When liquid has been spilled into equipment or metal object has entered through an opening.
When the equipment has been dropped and is damaged.

Maintenance and inspection



Prohibited

- **When the equipment is going to be cleaned, be sure to turn OFF the power of each equipment, and unplug the power cord from the AC outlet. Never use alcohol, benzene, thinner or any other flammable cleaning agent.**
Otherwise, it may result in fire or electric shock



- **Clean the plug of the power cord periodically by unplugging it from the AC outlet and removing dust or dirt from the plug, its periphery and AC outlet with a dry cloth.**
If the cord is kept plugged in for a long time in a dusty, humid or sooty place, dust around the plug will attract moisture, and this could cause insulation failure that could result in a fire.
- **For safety reasons, be sure to turn OFF the power to each piece of equipment when the inspections indicated in this manual are going to be performed..**
Otherwise, electric shocks may occur.



WARNING

Installation and environment of use



- **Do not install the equipment in any of the locations listed below. Doing so may result in failure or malfunction, equipment failing, or fire or injury.**
 - Close to facilities where water is used
 - where it may be exposed to direct sunlight
 - Close to the air outlet of an air-conditioner or ventilation equipment
 - Close to a heat source such as a heater
 - where the power supply is unstable
 - In a saline or sulfurous environment
 - where temperature or humidity is high
 - where there is freezing or condensation
 - In area prone to vibration
 - On an incline or in an unstable area
- **Because the equipment cable is long, take care that cables do not become tangled during use. Also, be careful not to get your feet caught in the cable.**
Otherwise, it may cause a malfunction of the equipment or the injury of the user due to tripping over the cable.
- **Non-medical equipment such as the battery charger, and access point unit cannot be used in patient's vicinity.**

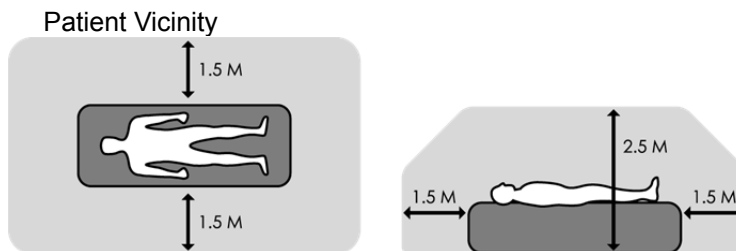

Power supply



- **Always connect the three-core power cord plug to a grounded AC power outlet.**
- **To avoid the risk of electric shock, this equipment must only be connected to a supply mains with protective earth™.**
- **To make it easy to disconnect the plug at any time, avoid putting any obstacles near the outlet. Otherwise, it may not be possible to disconnect the plug in an emergency.**
- **Be sure to ground the equipment to an indoor grounded connector. Also, be sure to connect all the grounded for the system to a common ground.**
- **Do not use any power source other than the one provided with this equipment.**
Otherwise, fire or electric shock may be caused due to leakage

Handling



- **Do not spill liquid or chemicals onto the equipment or, in cases where the patient is injured, allow it to come in contact with blood or body fluids.**
Doing so may result in fire or electric shock.
In such a situation, protect the equipment with a disposable covering as necessary.
- **Turn OFF the power to each piece of equipment for safety when not belong used.**

CAUTION

Handling the equipment

The Equipment must be handled with care to avoid personal injury or damage to the internal image sensor.



- Handle the equipment carefully.
- Do not submerge the equipment in water
- The internal image sensor may be damaged if something hits against it, or if it is dropped, or receives a strong jolt.

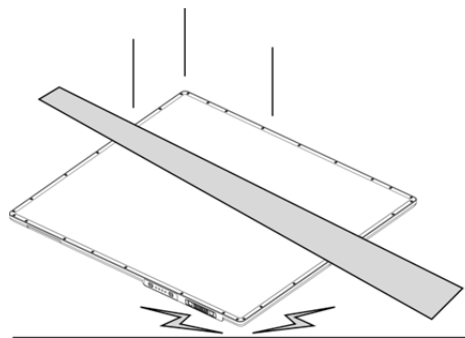

- Do not place excessive weight on the detector. Otherwise, the internal image sensor may be damaged.

<Load Limit>

Uniform load: 150 kg over the whole area of the detector

Local load: 100 kg on an area 40 mm in diameter

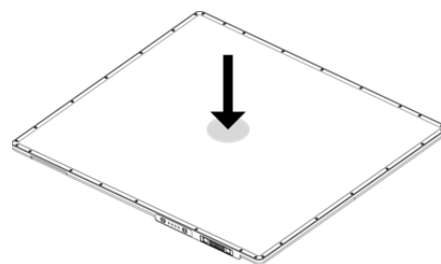
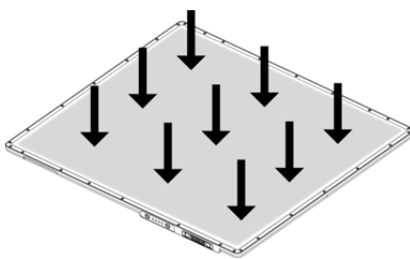

- Be sure to use the detector on a flat surface do it will not bend. Otherwise, the internal image sensor may be damaged. Be sure to securely hold the detector while using it in upright positions. Otherwise, the detector may fall over, resulting in injury to the user or patient, or may flip over, resulting in damage to the inner device.

1-2. Notes for using the equipment

When using the equipment, take the following precautions. Otherwise, problems may occur and the equipment may not function correctly

System Diagnostic

The Ecali1 software runs a system diagnostic.

Run Ecali1 software after installing the system and at least once a year. If an error occurs, report the detailed error information to DRTECH local dealer or distributor



CAUTION

The owner is responsible for ensuring that the system diagnostic is performed every year.
Do not try to use the system if the system diagnostic is failed.

Calibration

To ensure optimal performance of the system, it is important to verify that the system is calibrated.



CAUTION

The owner is responsible for ensuring that the system calibration is performed after the system installation is completed or the system is repaired. Do not try to use the system if system calibration is not performed.

Before exposure

- Be sure to check the equipment daily and confirm that it works properly.
- Sudden heating the room in clod area will cause condensation to form on the equipment. In this case, wait until the condensation evaproates before performing an exposure. If the equipment is used while the condensation formed on it, problems may occur in the quality of captureed image. When an air-conditioner is used, be sure to raise/lower the temperature gradually so that a difference in temperature in the room and in the equipment does not occur, to prevent condensation.

During exposure

- Do not use the selected frequency chanel for other wireless device. Mutual interference may affect the image data transmission rate.
- Do not use the detector near devices generating a strong magnetic field. Doing so may produce image noise or artifacts.

Electric Shock Hazards

- To reduce the electric shock hazard, the system must be connected to an electrical ground.
- A three conductor AC power cable is supplied with this system to provide the proper electrical grounding. The power cable must be plugged into an UL-approved three-contact electrical outlet.
- Do not disassemble or modify the product as it may result in fire or electric shock. There are no operator serviceable parts or adjustments inside the systems. Only trained and qualified personnel should be permitted access to the internal parts of the system.
- If an APPLIANCE COUPLER or Mains Plug or other separable plug is used as the isolation means to safety

Disinfection and cleaning

- Wipe it with a dry cloth slightly damped with a neutral detergent.
- Do not use solvents such as alcohol, thinner or benzene. Doing so may damage the surface of the equipment
- Do not clean the system with turning the power on.

Operating/storage environment

- Be sure to use and store this equipment under the conditions described below:.

	Temperature	Humidity	Atmospheric pressure
Operating environment	10 to 35 °C	30 to 85 % RH	700 to 1060 hPa
Transport & Storage environment	-15 to 55 °C	10 to 90 % RH	500 to 1060 hPa

- Do not expose this equipment to high temperatures and/or high humidity. Malfunction is occur.
- When not in use, keep the detector, handle unit, and grid in a designated location or in a location where they are safe and cannot fall down.

Notes on disposal

- Disposal of this product in an unlawful manner may have a negative impact on health and on the environment. When disposing of this product, therefore, be absolutely sure to follow the procedure which is in conformity with the laws and regulations applicable in your area.
- The expected life span of EVS 3643 system is about 3 years

Handling the equipment

- The equipment must be handle with care to avoid personel injury or damage to the internal image sensor.

The EVS 3643 Wireless is advanced wireless digital radiographic equipment in the DRTECH Exprimer series. This equipment is designed to provide the highest resolution and sensitivity in the series. In addition, the wireless LAN (IEEE 802.11n*) communication feature improves the operability, and high-speed processing.

2-1. Features

- Wireless LAN communication (IEEE 802.11n*) includes a lightweight and thin detector that is easy to handle.
- The shape of the detector, which is identical to that of a conventional film cassette complying with ISO4090, enables digital radiography in the existing analog radiography configuration
- The new sensor with 140 μm of pixel pitch and CsI (Cesium Iodide) used for the scintillator produces high resolution (approx. 7.86 Mega pixels) digital images within the effective imaging area (358 x 430 mm) with low doses of X-rays
- Depending on the operating conditions at each site, the wiring unit (optional) enables the equipment to be used through expansion to a wired connection
- At the time of installation, set a specific channel in the frequency band of 5.0 GHz before using the LAN. Note that the available frequency band for this standard varies, depending on the local radio laws, regulations and system requirements.

2-2. Intended use

- The EVS 3643 Digital X-ray detector is indicated for digital imaging solution designed for providing general radiographic diagnosis of human anatomy. This device is intended to replace film or screen based radiographic systems in all general purpose diagnostic procedures. This device is not intended for mammography applications

2-3. System Configuration

Generally, the EVS 3643 detector is used in system configuration as illustrated below:

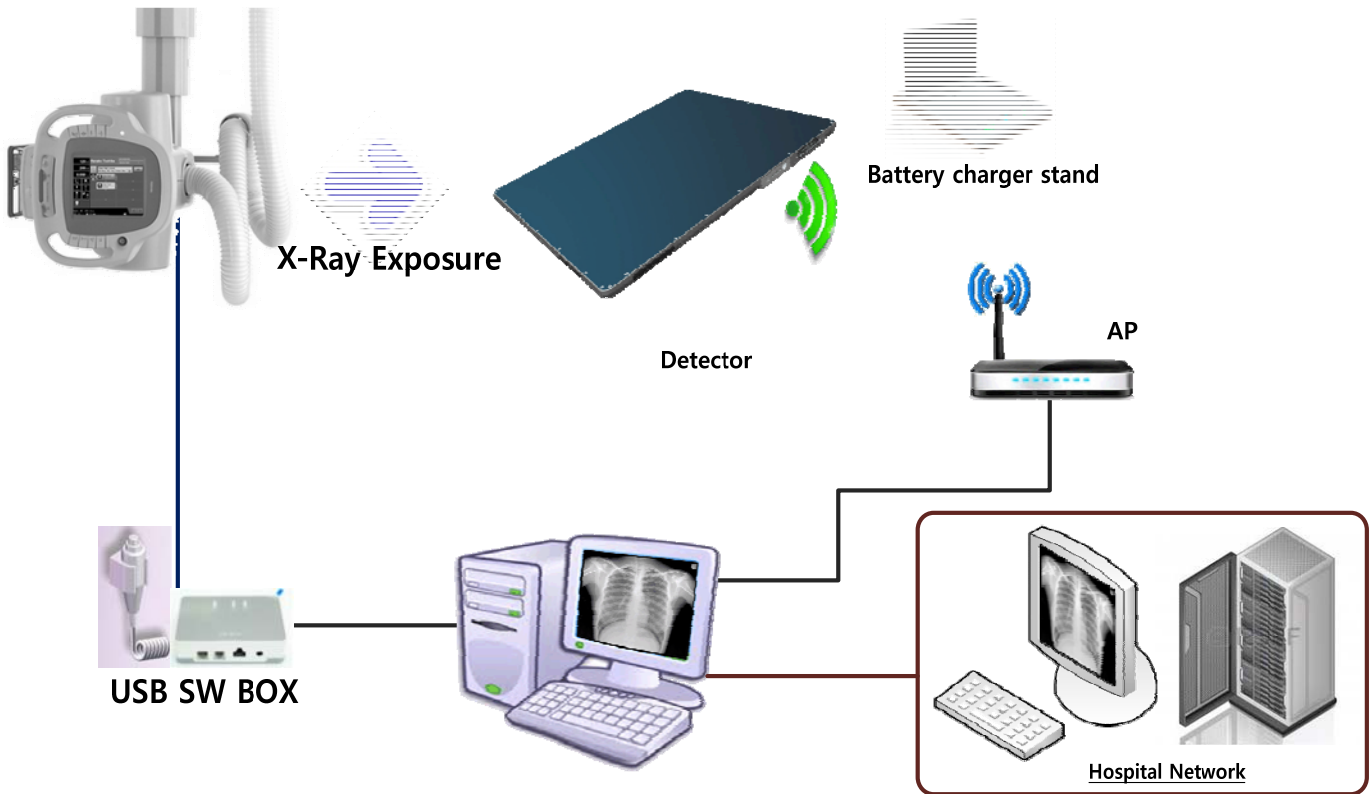

Figure 2.1 EVS 3643 system configuration

Wireless communication is established between the EVS 3643 Wireless detector and System Control Unit. The EVS-3643 system is compliant with IEEE 802.11a/b/g/n (2.4 GHz / 5 GHz). The available frequency band may vary depending on local radio laws and system requirements. Consult your local dealer for the frequency available in your area.



- Use of multiple WLAN devices within the same frequency band may interfere with each wireless communication and cause a decline in transmission speed
- Do not cover or block the wireless module of the detector. Otherwise, the transmission speed or operable distance may be reduced.
- Recommended maximum operating distance of wireless communication between the detector and system synchronization unit is 8 meters.

3. Product description

EVS 3643 Wireless system consists of detector, system synchronization unit (SSU), CDs and relevant accessories. (Refer to chapter 3-1 "Product Components" for CD information)

<p>X-ray Detector (EVS 3643)</p>	<p>System Synchronize Unit (EVS-SSU01) Option</p>	<p>Access Point (D-Link DIR-850L)</p>
		
<p>USB Switch Box</p>	<p>Hand Switch</p>	<p>Generator Interface Cable (15m) Option</p>
		
<p>LAN Cable (Gigabit LAN 10 m)</p>	<p>AC Power Cable (2m) Option</p>	<p>Tether Interface (3 m)</p>
		
<p>Interface Cable(7 m), Option</p>	<p>Power adaptor (12V, 7.08A)</p>	<p>Adaptor cable (3 m) Option</p>
	 <p><small>©Premier Farnell Copying of image is prohibited.</small></p>	





Functional cable (0.5 m)	Battery charger (EVS-BCS)	Battery pack (EVS-MBP)
		
	<p>CD(Software / Calibration)</p>	<p>Maual (Hard Copy)</p>
		<p>DRTECH EVS 3643 System. Safety and Regulatory Information. with User's Maual.</p>  <p>DRTECH OPTICUM</p>

Table 3.1 EVS 3643 packaging

3-1. Product component

Item	Product name
Flat panel detector	EVS 3643(Scintillator: CsI : TI) 2.98 kg
System synchronization unit (SSU)	EVS-SSU01 : 2.2 kg Optional
Battery charger and Battery pack	EVS-BCS (charger): 0.5 kg EVS-MBP (battery pack): 0.24 kg
CD (Software / Calibration)	Document: User 's Manual (PDF) Calibration Data: Defect Map, Gain, Post Offset, Pre Offset Calibration & Configuration S/W: ECali1
User's Manual	Hard Copy
Accessories	AC Power Cable (2m) Generator Interface Cable (15m, Optional) USB Switch Box Hand switch LAN Cable (10m, Direct, 1000BASE-T) Tether Cable (3m, Optional) Adaptor cable (3m, Optional) Functional cable (0.5 m) Power adapter Interface Cable (7m, Optional) License Dongle Key (USB)

Table 3.2 Product componets

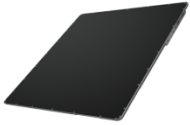

WARNING

The use of accessories and cables other than those specified, with the exception of **EVS 3643 Wireless** accessories and cables sold by DRTECH Co., LTD. as replacement parts for internal components, may result in increased emissions or decreased immunity of the equipment. Accessory equipment connected to the analog and digital interfaces must be certified according to the respective IEC standards. All combinations of equipment must be in compliance with IEC 60601-1-1 system requirements. Any person who connects additional equipment to the signal input or signal output ports configures a medical system, and is therefore responsible for ensuring that the system complies with the requirements of the system standard IEC 60601-1. If in doubt, consult DRTECH technical support representative.

Workstation (Recommended and minimum but NOT included)

Item	Specification
Operating system	Windows 7 64 bit SP1 (Professional Edition or higher)
CPU	Intel Core i5 2600 or higher (or compatible CPU)
Memory	4GB or higher
Hard disk	1TB or higher
LAN card	Gigabit (Detector only) Intel® PRO 1000 Series (Gigabit LAN Card for network interface) Min. Requirements: 1Gbps, Jumbo Frames: 9K Receive Descriptors: 2K (higher than 1024) This is not dedicated to DICOM
Monitor	1024 x 768 or higher
Optional disc drive	CD or DVD R/W

Table 3.3 Workstation**Grid (Recommended but Not included)**

Item	Description
SID	100 / 130 / 150 / 180 cm
Ratio	8 : 1
Frequency	215 Line/inch
Inter spacer	Al

Table 3.4 Grid specifications**3-2. X-ray Imaging condition****X-ray Energy Range**

40kVp ~ 150kVp

Reliability (Lifetime Dose)

More than 74Gy (35uGy x 365days x 24hours x 60minutes x 60seconds/15sec)

4-1. Detector specification

Item	Description
Model	EVS 3643
Purpose	General Radiography
Pixel Pitch	140 um
Scintillator	CsI (Cesium Iodide)
Image Matrix Size	2560 × 3072 pixels
Effective Imaging Area (H x V)	358 x 430 mm
Image Acquisition and Transfer Time	< 3 sec.
Spatial Resolution	Min. 3.5 line pair/mm
Rated Power Supply	DC +12V 2 A
Wireless	Powered by the battery pack (4,000 mA h)
Wired	Powered by SSU using tether interface Powered by Power adopter using tether interface
Power Consumption	Max. 24 W
Network Interface	14 bit Digital Output Ethernet (1000BASE-T)
Dimensions (mm)	386 (H) × 460 (V) × 14 (D)
Weight	2.98 kg
Environmental Requirements	
Operation	Temperature: +10 ~ +35°C Humidity: 30 ~ 85% RH(Without Condensing) Atmospheric pressure: 700 ~ 1060 hPa
Storage and Transportation(unpacked)	Temperature: -15 ~ +55°C Humidity: 10 ~ 90% (Without Condensing) Atmospheric pressure: 500 ~ 1060 hPa

Table 4.1 Detector specifications

†**Tether Interface:** Allows the detector to communicate with SSU via Ethernet cabling when wireless communications is not available or higher speed data transfer is necessary

4-2. Detector component

The detector is designed to capture radiographic images.

Captured images are transmitted to the EVS 3643 image-capture computer using the wireless/wired data transfer

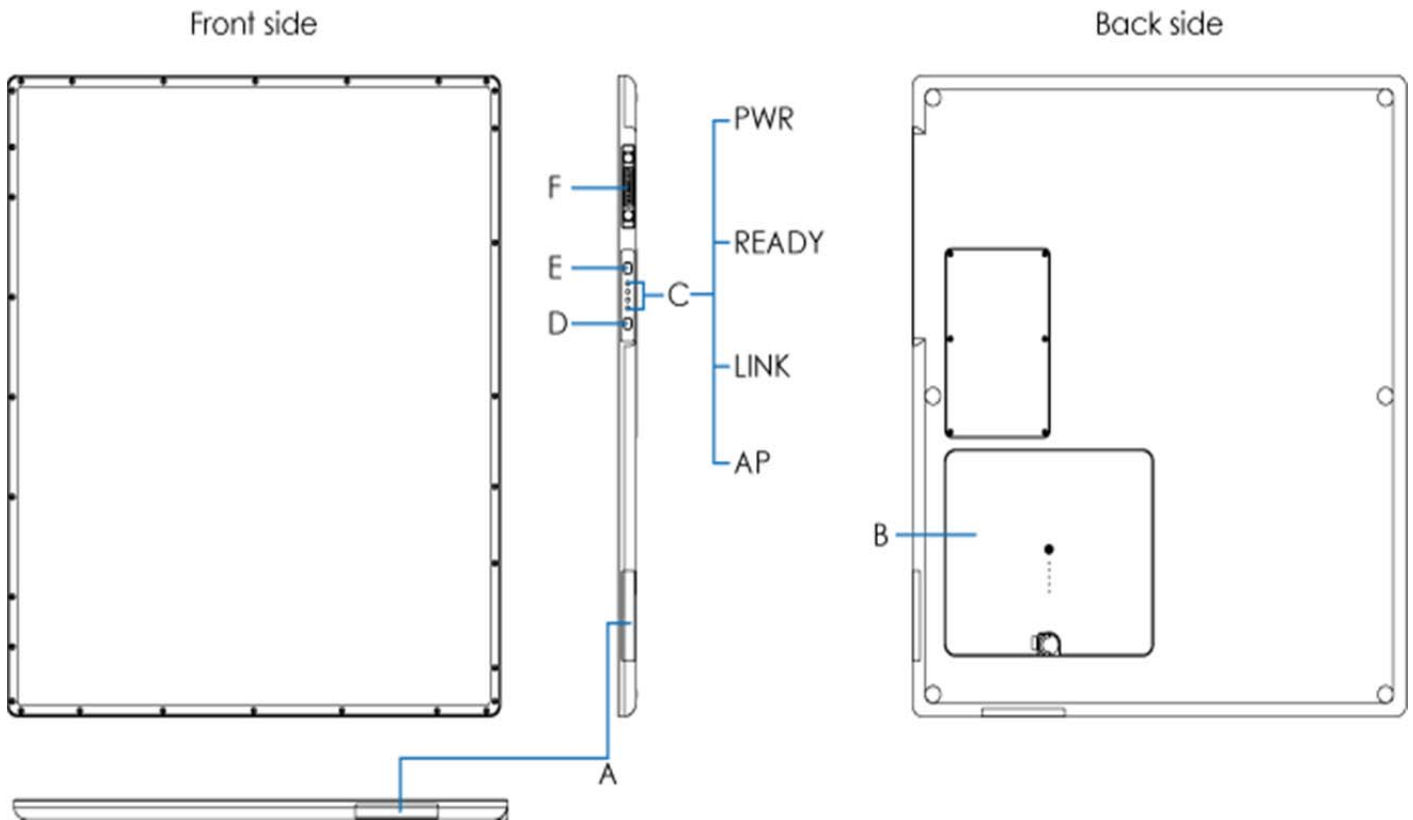

Figure 4.1 Detector components

- A. Wireless antenna :Transmits image data with wireless communication (IEEE802.11n).
- B. Battery Pack : Supplies electric power to the detector while communication wirelessly
- C. Status indicators
 - AP: Alter button for Wired/Wireless(2.4 GHz / 5 Hz)
 - Link: Shows detector registration and connection status.
 - Ready:shows data communication status
 - Power: Shows power on/off status of the detector.
- i** Simultaneous blinking of two or more LED lamps indicates a system error.
- D. AP Button: registration detector.
- E. Power Button: Detector power on / off
- F. Connector: Data communication and power supplying through tether cable

4-3. Detector dimension

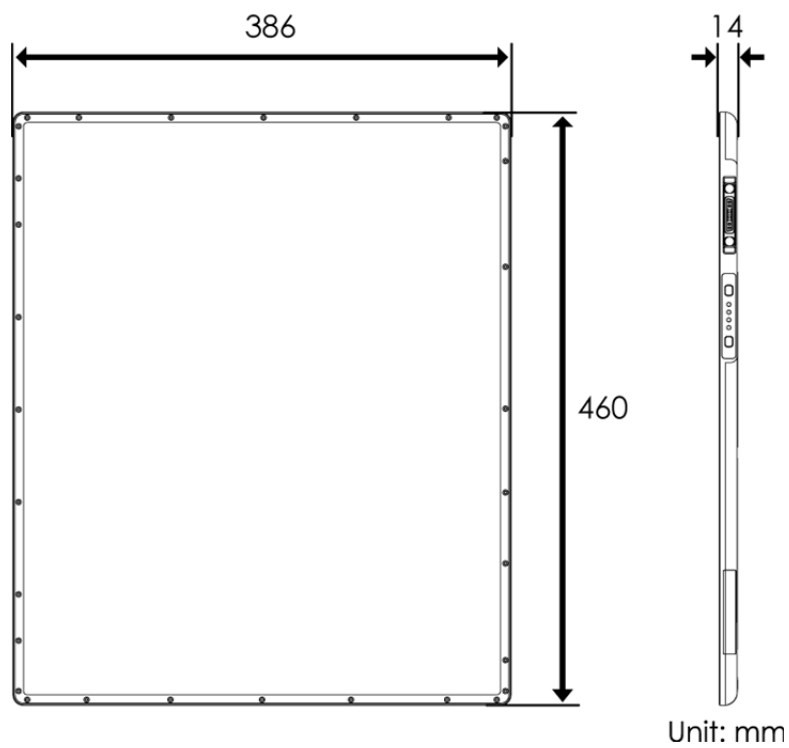
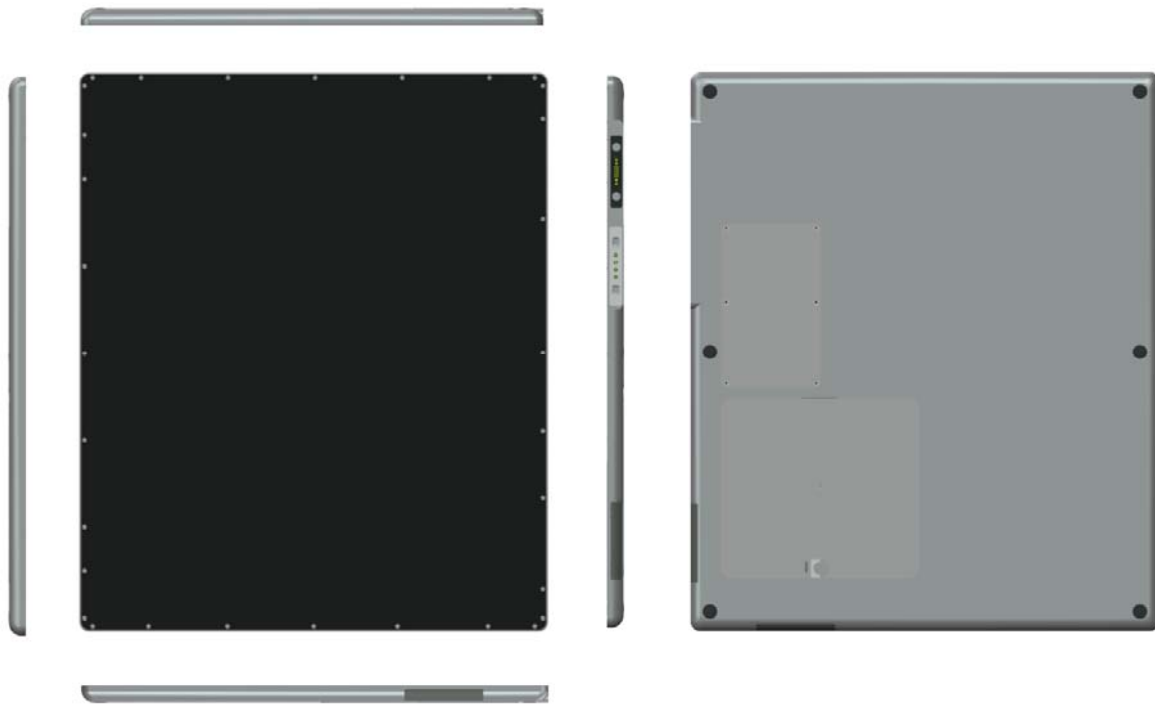

Figure 4.2 Detector dimension

4-4. Power supply and SSU (System synchronization unit)

4-4-1 SSU Specifications

Item	Description
Model	EVS-SSU01
Power Supply	Input: AC100 to 240V, 50/60Hz Output: DC +12V 8.3A, 75W
Dimensions (W x H x D)	260 mm x 248 mm x 49 mm
Weight	2.2 kg
Environmental Requirements	
Operation	Temperature: +10 ~ +35°C Humidity: 30 ~ 85% RH(Without Condensing) Atmospheric pressure: 700 ~ 1060 hPa Altitude: Max. 2 km
Storage and Transportation(unpacked)	Temperature: -15 ~ +55°C Humidity: 10 ~ 90% (Without Condensing) Atmospheric pressure: 500 ~ 1060 hPa Altitude: Max. 2 km

Table 4.2 System synchronization unit specifications

4-5. Battery Charger and Battery Pack

4-5-1 Battery Charger

Item	Description
Model	EVS-BCS
Simultaneous Charging	Battery Pack 2 EA
Charging Time	3 hours
Rated Power Supply	DC +12 V, 6 A Max.
Dimensions (W x H x D)	180 mm x 255 mm x 35 mm
Weight	0.5 kg

Table 4.3 Battery charger specifications

4-5-1-1 Battery charger components

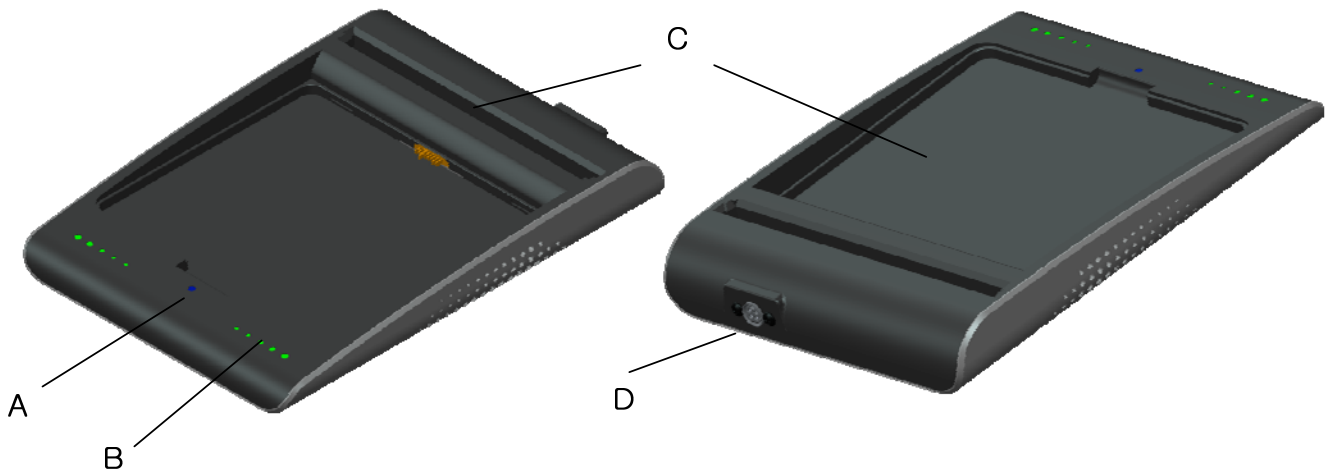

Figure 4.4 Battery charger

- A. Power indicator : indicates the power on/off status..
- B. Charging indicator : Indicates the charging status.
- C. Battery compartment: Insert the battery pack to charge.
- D. DC Input : Connect the DC adapter to supply electrical power to the battery charger

4-5-1-2 Battery charger dimension

Unit : mm

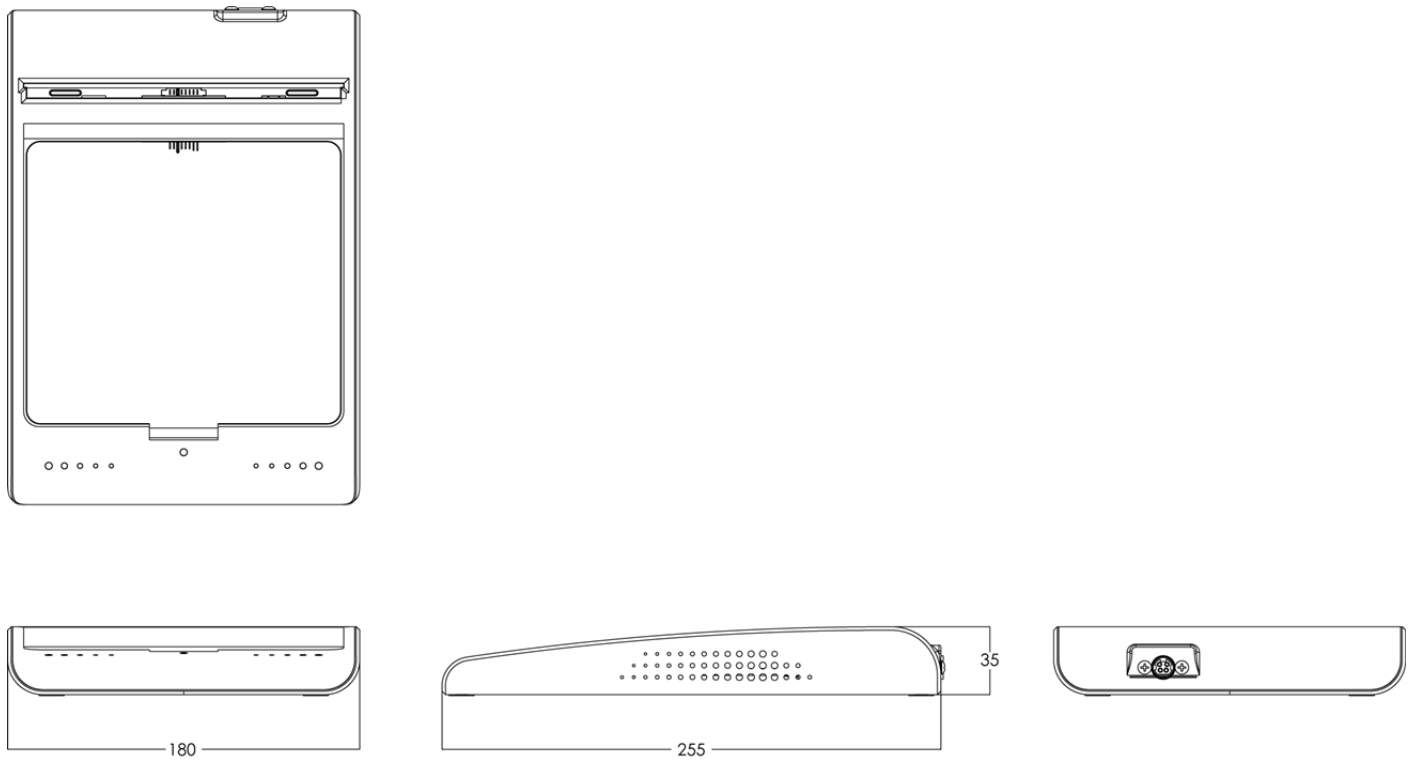

Figure 4.4 Battery charger system

4-5-2 Battery Pack specification

Item	Description
Model	EVS-MBP
Cell Type	Lithium Polymer
Number of Cell	2S1P (2series 1 Parallel)
Rated Power Supply	Output : DC +7.4 V
Life	Approx. 500 times (charge / discharge 1 cycle)
Dimensions (W x H x D)	163 mm x 148 mm x 7 mm
Weight	0.24 kg

Table 4.5 Battery charger specifications

4-5-2-1 Battery charger components

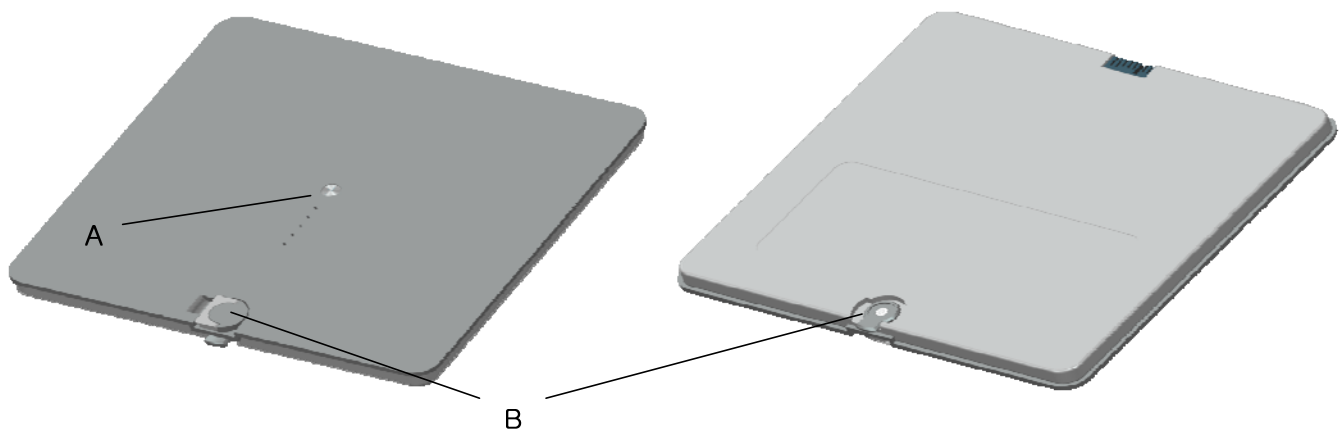

Figure 4.5 Battery pack

- A. Charging indicator : Indicates the charging status
- B. Latch knob : rotating on /off for battery swap

4-5-1-2 Battery pack dimension

Unit : mm

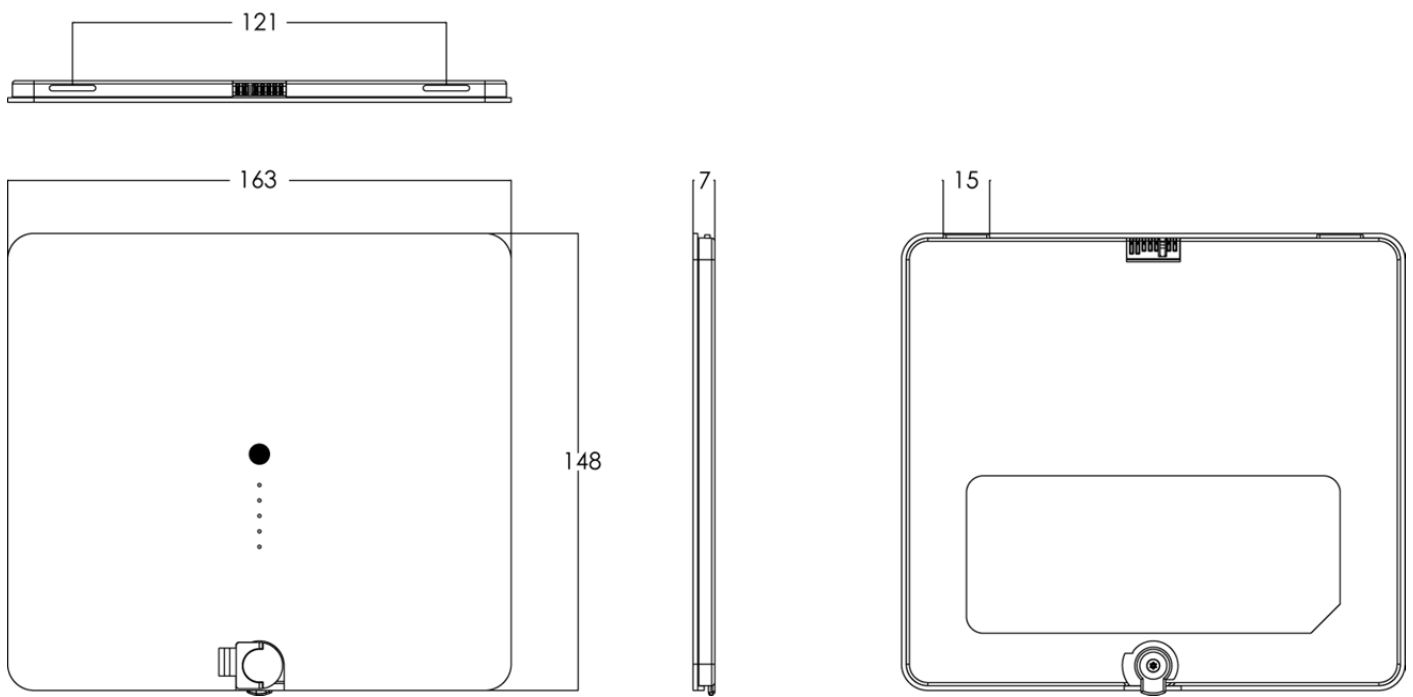





Figure 4.6 Battery pack dimension

4-5-3 Charging Battery Pack

The battery pack supplies power to the detector during wireless connection.

Be sure to use only the dedicated battery pack and fully charge it before use.

- Connect the power adapter to the DC Input port of the battery charger. the power LED lights in blue indicating the presence of direct current (DC) power.
- Insert the battery pack into the battery charger. Charging starts automatically. The charge LED lights green when the battery pack is being charged. After the battery pack is charged completely, all level of the charge LED will going to luminance
- Gently pull the charged battery pack to remove from the battery charger

	WARNING	Securely plug the power cord into the power source. If contact failure occurs, or if dust or metal objects come into contact with the exposed metal prongs of the plug, fire or electrical shock may occur
	CAUTION	Be sure to stop charging the battery pack when the charge LED lights in green beyond the specified charging time. Not doing so may result in battery pack overheating or smoking or in explosion or fire.
	CAUTION	You must use the power adaptor that is certified with IEC 60950 or IEC 60601-1.
	Two batteries can be charged at the same time.	
	It takes approximately two hours to fully charge a battery pack. The required charging time may vary depending on the temperature and remaining battery level.	

4-6 Wireless access point(Optional)

This antenna equipment relays captured images from the detector to the control system. No operation is required for this equipment while using the EVS Digital Radiography system.

4-5-1 Access point Specifications

Item	Description
Model	Access Point (AP)
Power	D-Link DIR-850L
Communications	DC 12V/2A
Dimensions (W x H x D)	IEEE 802. 11n/g(2.4 GHz), IEEE 802.11ac/n/a (5GHz)
Weight	85.73 x 111.13 x 145.28 mm
	0.28 kg
Environmental Requirements	
Operation	Temperature: 0 ~ +40 °C Humidity: 10 ~ 90% RH(Without Condensing)



CAUTION

Do not use the wireless access point within the patient's vicinity

The EVS 3643 Detector is properly adjusted at installation by the service engineer. If you encounter any problems during normal operation or daily inspections, consult your sales representative or local DRTECH dealer.

General workflow

The following workflow indicates the procedures after startup of the EConsole1 and other system equipment

5-1. Preparing to use the detector

Attach a fully-charged battery pack to the detector.

¹⁾ : A procedure in order to register the detector to a specific digital radiography system

5-2. Operating the detector

1. Turn on the detector

²⁾ : Network connection between the EVS 3643 wireless detector and the EConsole1

2. Resister¹⁾ the detector and make connection²⁾ to the EConsole1 power supply to the detector

³⁾ :
 • Selection of EVS 3643 wireless from the Exprimer series detector
 • Selection of wireless/wired data transfer

3. Conduct Examination

• Select or resister the patient information

Loop back procedure for each patient

• Select the protocol (selection³⁾ of the detector)

- Arrange the patient in the correct posture
 - Position the X-ray generator to adjust the exposure field
 - Check all the conditions

Loop back procedure for each body part

Check the captured images
 • List the images
 • Transmit the images

Sterilize the portion of the detector that has been in contact with a patient

• Conduct the next examination

5-3. Ending use of the detector

1. Turn off the detector

2. Remove the battery pack

For details, refer to the operation manual or setup guide of the EConsole1

5-1. Preparing to use the detector



CAUTION

Be sure to use only the dedicated power supply for the EVS-3643 detector

Standard Configuration

Configuring with SSU (power supply) to the detector

- i** Make sure that the cable is placed to the connector (detector side)

Figure 5.1 EVS 3643 System Configuration

5-2. Operating detector

1 Turn on the detector

- i** Before operating the detector, start up the EConsole1

Press and hold the POWER button
(approx. 1 second)

Power lamp(Blue) light up

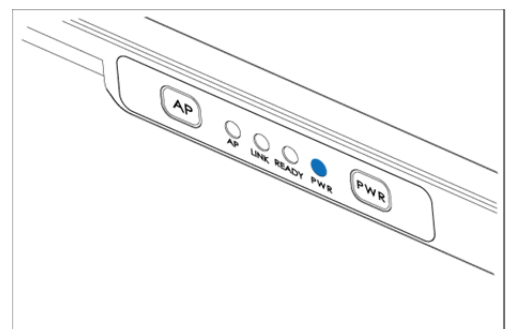

2 Register the detector and make connection to the EVS control system

Registration

Press and release the AP button

Link lamp flashes.

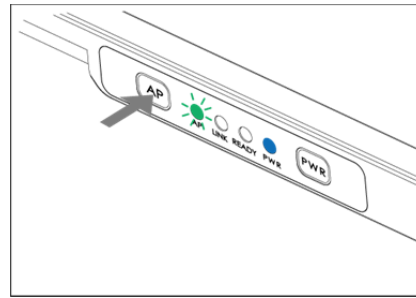

- i** When the AP Lamp flashes 1 time in 2sec, wired mode status has showing.
- i** When the AP Lamp flashes 2 times in 2sec, wireless (2.4 GHz) mode status has showing.
- i** When the AP Lamp flashes 3 times in 2sec, wireless (5 GHz) mode status has showing.

Connection

Network connection between the internal wireless module of the detector and the wireless access point/EVS control system is secured automatically

The link lamp lights up when the detector is registered and the communication connection is established

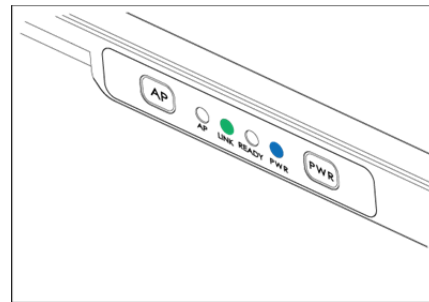

- i** The LINK lamp does not light up when the detector is not registered or the communication connection is not established.
- i** When the Ready and LINK Lamp flash, a communication error has occurred.
See Troubleshooting.

3 Conduct examination

For details about operation, refer to the **Operation Manual for the ECali1**.

- i) Select the patient information or protocols on the screen and start the examination.



The READY lamp flashes during preparation for examinations.

The READY lamp lights up when the detector and EConsole1 change to exposure ready status.

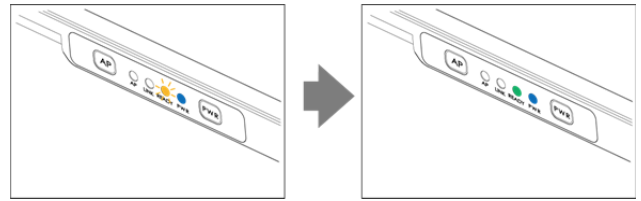

- Arrange the patient in the correct posture and position the detector aligning it with the target body part.
- Position the X-ray generator to adjust the exposure field.
- Check all conditions before exposure.
Make sure that four LED lamps (POWER, READY, LINK, AP) are lit. This means that the system is ready to start an examination

i A communication error has occurred when two or more lamps flash.

i When the READY lamp (green color) flashes slowly, the detector is in detector selection status (Sleep).

The detector enters detector selection status automatically when it has not been used for a certain period of time.

ii) Press the exposure switch of the X-ray generator.
Images captured with the detector are transmitted to the EConsole1 and appear on the monitor.

- Check the images on the monitor.
- If any uncompleted protocols remain, repeat the procedure ii).

ii) Click the button for ending the examination
images are stored automatically

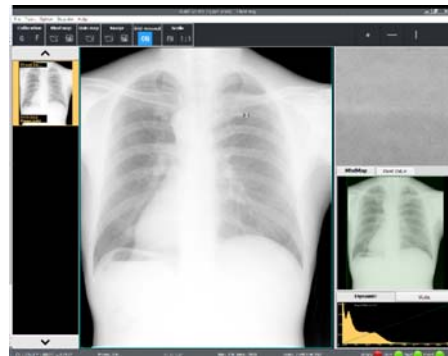





- To conduct examination for another patient, repeat the step 3.

	<p>IMPORTANT</p>	<p>Sterilize the portion of the detector that has been in contact with a patient to prevent infection</p>
---	-------------------------	---

 A signal strength indicator appears on the screen of the ECal1 computer. It shows the wireless communication level between the detector and the ECal1.

Keep the wireless communication level stable on capturing or transmitting images.

Display	Signal strengt (communication stability)	Status	Required actions
	Very high (Stable)	Normal	-
	High (Stable)	Normal	-
	Low (Unstable)	Unstable communication. Communication speed is lowered	Check whether there is any obtacle (e.q., your hands)between the wireless module and the wireless aces point. If there is any obtacle, remove it. If the problem cannot be resolved. Consult your sales representative or local DRTECH dealer
	No signal (Communication failed)	Cannot comuncations	Confirm that detector and the access point are turned on. If the problem cannot be resolved. Conult your sales representative or local DRTECH dealer

5-3. Ending use of the detector

Turn off the detector

Press the SSU POWER button.
All the LED lamps are off.

Detector status list

Lamp type	Power Lamp	Ready Lamp		Link Lamp	AP Lamp
Color	 Blue	 Green	 Orange	 Green	 Green
Power ON	○	x	x	x	x
During detector registration	○	x	☆	☆	☆
Detector registration completed (1 Sec,)	○	○	☆	○	☆
Communication established	○	x		○	☆
During exposure preparation	○	x	☆	○	☆
Ready status or performing an examination (Ready)	○	○	-	○	☆
Detector selection status (Sleep)	○	★	-	○	-
During image data transmission	○	○ / ★	-	★	-
Power OFF	x	x	-	x	-

- : Light on ☆ : Flashes (On/Off status changes every second)
 x : Lights off ★ : Flashes slowly (On/Off status changes every 2 seconds)
 - : Unspecified status

6-1. Using the wireless detector with other EVS series detectors in a same system

The ECali1 with the EVS 3643 detector enables connection with EXPRIMER series detectors other than that EVS 3643 detector, according to preset settings. Select a detector when conducting an examination. For details, consult your sales representative or local DRTECH dealer.

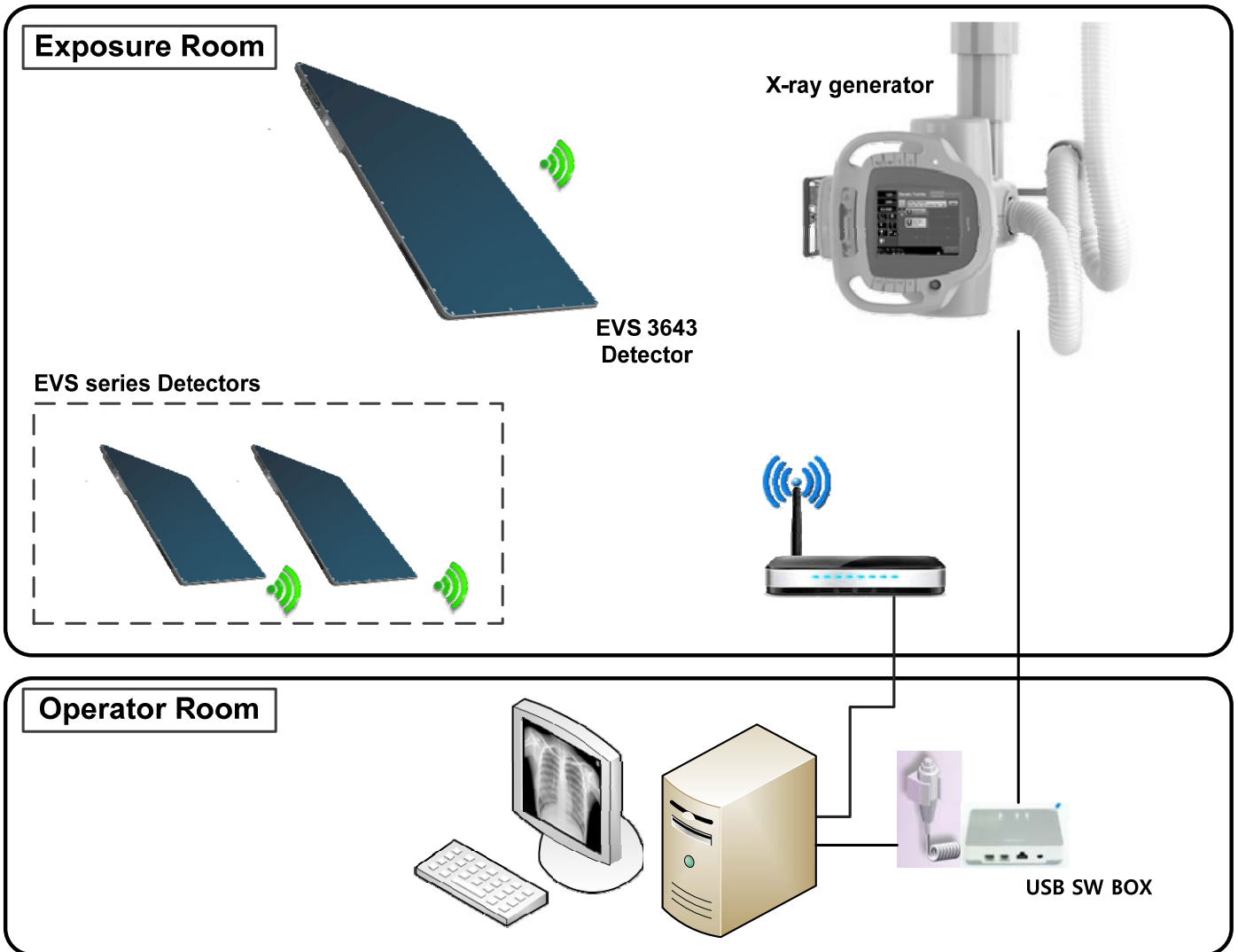

Figure 6.1 Detector dimension

6-2. Sharing the detector among different systems

The EVS 3643 detector can be used in two or more systems in which protocols for the detector have already been preset. For details, consult your sales representative or local DRTECH dealer

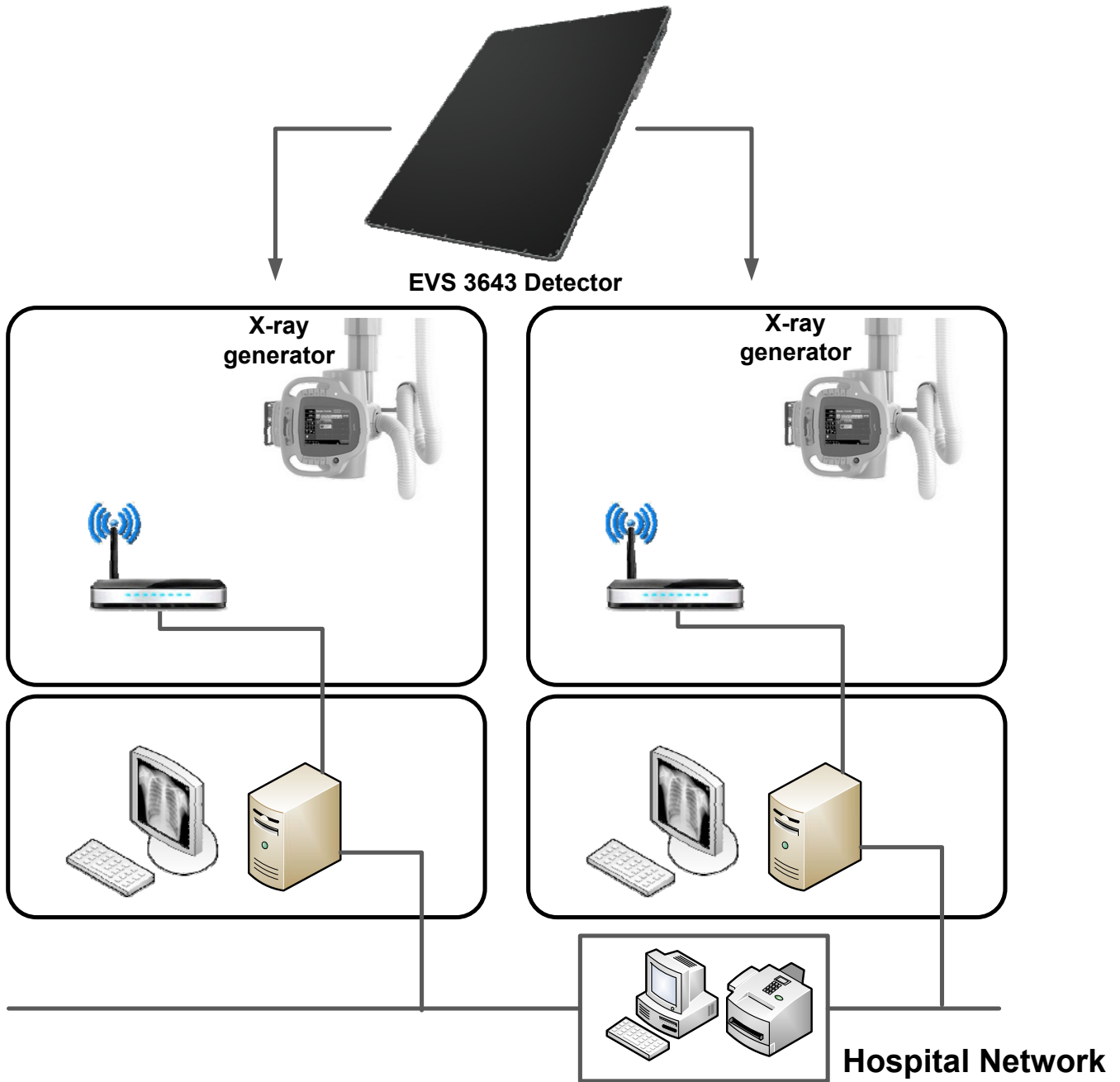

Figure 6.2 Sharing the detector among different systems

6-3. AED mode

- AED mode can make exposure as using internal storage in the detector with out a wireless connection
- The images can be transmitted to a PC and used by connecting the detector to Viewer. The transmitting images in the detector are removed automatically.
- Image processing and correction are available after connecting the detector to Viewer

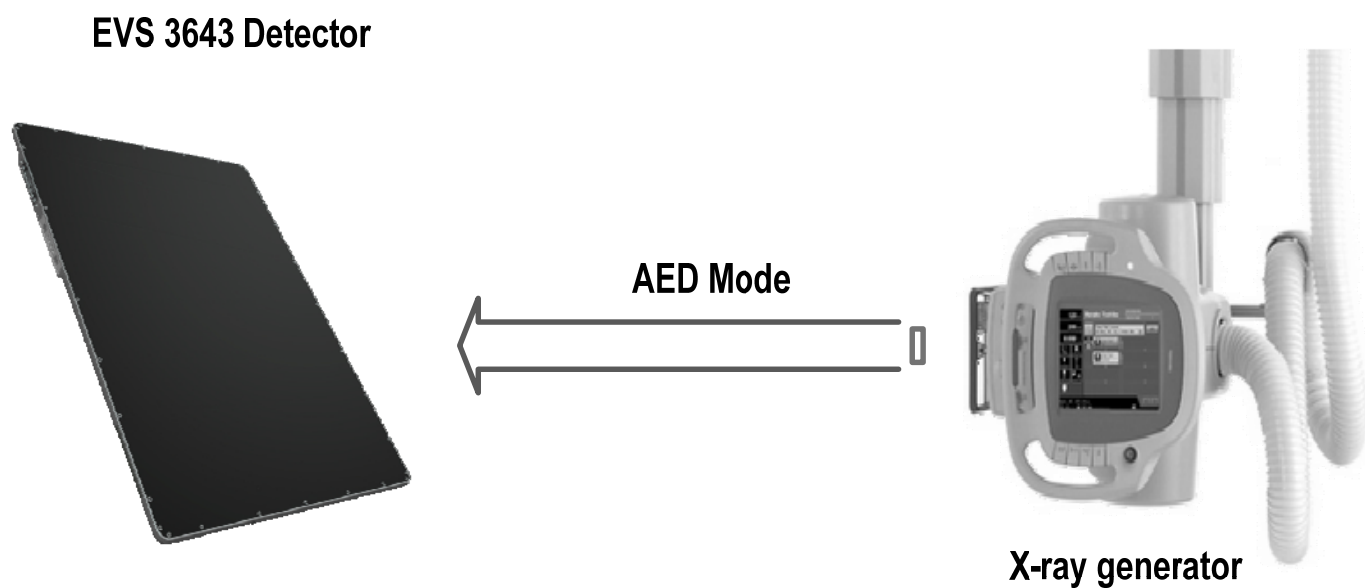

Figure 6.3 AED mode

6-4. Wiring connections

The EVS 3643 detector has a cable connector. With the wiring unit (optional), it is possible to expand from a wireless configuration to a wired configuration (see the figure below). Wired configuration is suitable for use where the detector is set in a Bucky stand and table in place of a film cassette. In this configuration, for the reason that data communication and power supply are made via a cable, users do not have to be concerned about power and wireless communication failure. This reduces the time and labor involved in charging and replacing.

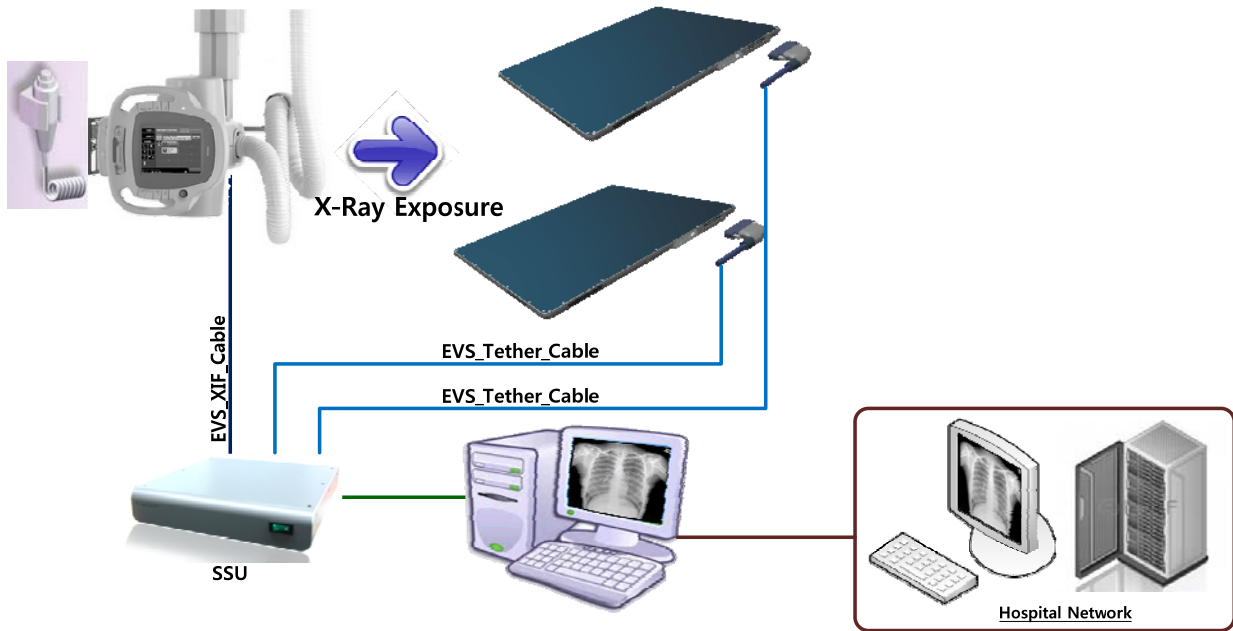

Figure 6.4 Wiring connection with SSU

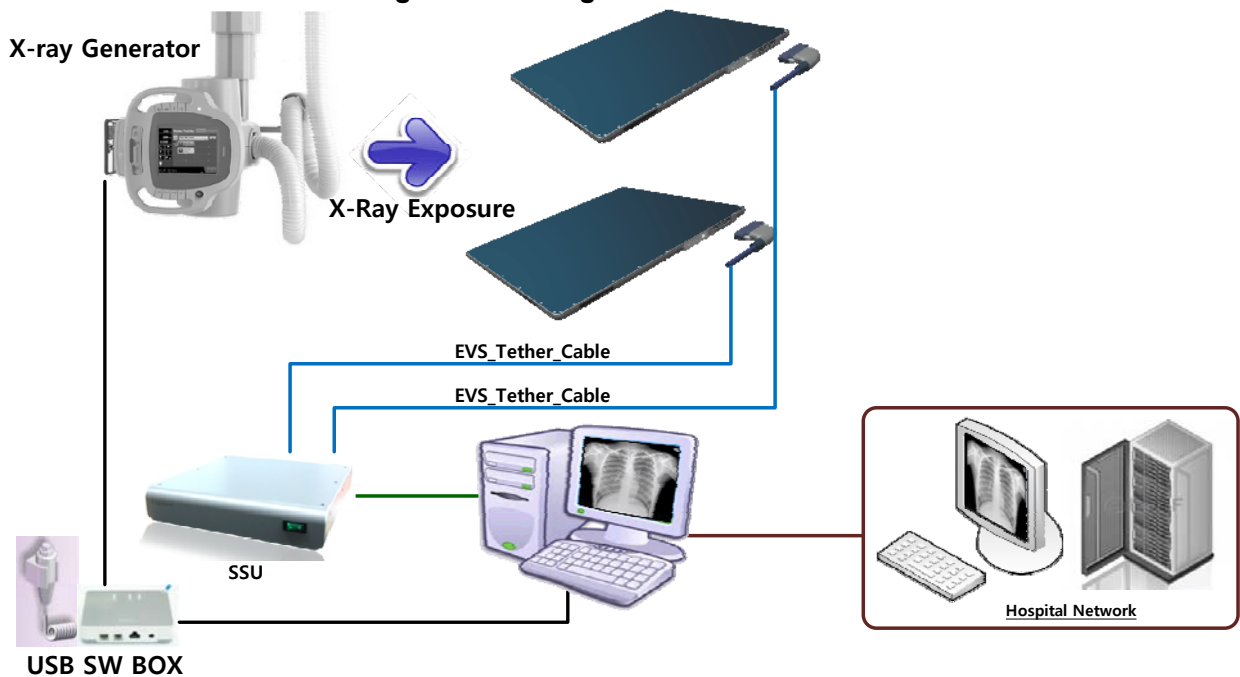

Figure 6.5 Wiring connection with USB S/W BOX

For details about wired configuration, consult your sales representative or local DRTECH dealer.

7-1. Hardware Installation

This section describes how to connect the EVS 3643 system (Detector)



CAUTION

Installation of this equipment should be made by licensed and authorized personnel.

7-1-1 EVS 3643

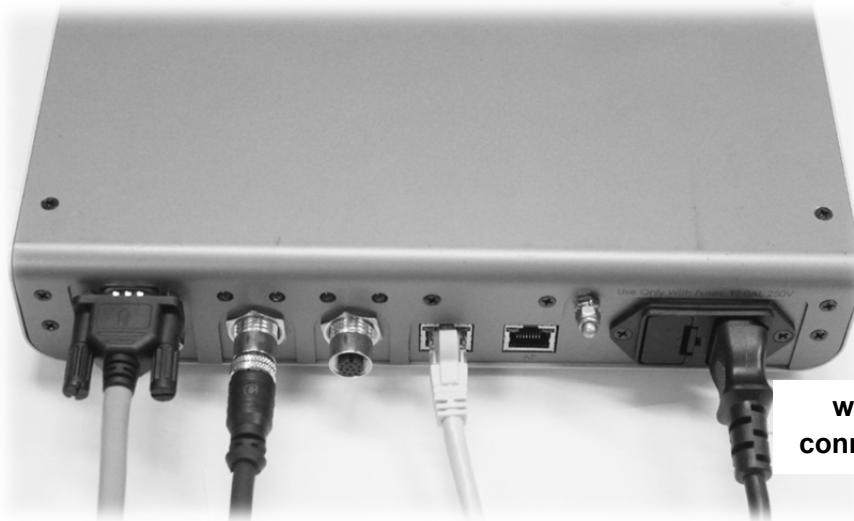

wiring
connection

- 1 Connect the one end of the generator interface cable to the X-ray port of SSU, and the other to the port of the x-ray generator.



- 2 Connect the LAN cable to PC port of SSU, and the other to the LAN Card connector of workstation assigned for the data transfer

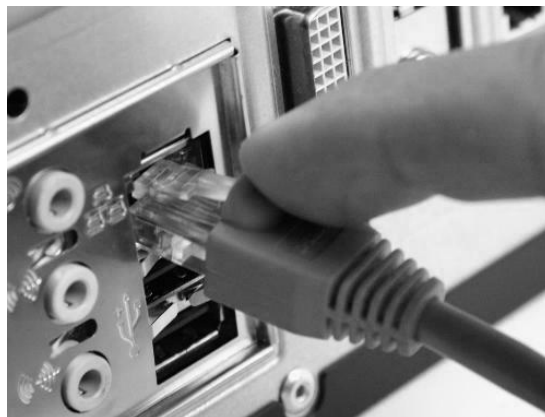

- 3 To transmit image data and connect power with Tether Interface, connect the Tether interface cable to FPD 1 or FPD 2 of SSU

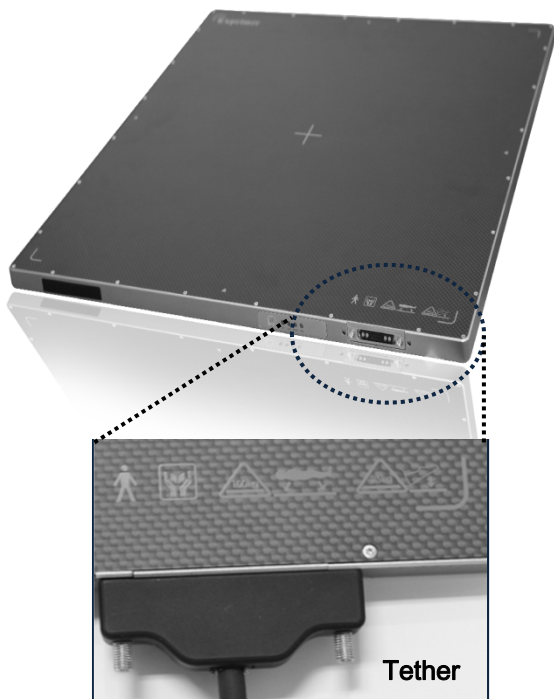

4 Connect the power cable to the AC pport of the SSU to supply power



CAUTION

This equipment must only be connected to a main power with protective earth



5 Turn on the power switch in the front of the SSU



7-2. ECali1 Installation

7-2-1 System Requirements

Table 7.1. System requirement

Items	Minimum	Recommended
CPU	Intel i3-2100	Intel i5-3470
RAM	2 GB	4 GB
HDD	100 GB	500 GB
VGA	Intel HD GRAPHIC 2000	NVIDIA GeForce GT630 1GB
ODD	CD-ROM	DVD Recorder
OS	Windows XP Pro SP2	Windows 7 Pro 32 / 64bit
Display Size	17 inch	23 inch
Display Resolution	1024 x 768	1920 x 1080

√ Efficient operation is not guaranteed for PCs that do not comply with the recommended specification.

7-2-2 Installation & Removal

Installation prerequisites

✓ Windows 7

Windows 7 users must set the User Account Control (herein after 'UAC') permission and disable the firewall.

1) UAC Setting

- ① Click the start icon 
- ② Click 'Control Panel'
- ③ Select 'User Accounts'
- ④ In the User Accounts window, click 'User Accounts'
- ⑤ In the User Accounts task window, click 'Change User Account Control Setting'
- ⑥ Adjust the slider to the 'Never notify,' and then click 'OK'.

2) Disabling the Firewall

- ① Click the Start icon 
- ② Click 'Control Panel'
- ③ Click 'Security'
- ④ Click 'Windows Firewall'
- ⑤ Click 'Turns Windows Firewall on or off' on the left
- ⑥ Click 'Off (not recommended),' and then click 'OK'

✓ Windows 8

Windows 8 users must set the User Account Control (herein after 'UAC') permission, Disable the firewall and run the program as the system administrator.

3) UAC Setting

- ① Click 'Setting' on the right hand menu
- ② Click 'Control Panel'
- ③ Select 'User Accounts'
- ④ In the User Accounts window, click 'User Accounts'
- ⑤ In the User Accounts task window, click 'Change User Account Control Setting'
- ⑥ Adjust the slider to the 'Never notify,' and then click 'OK'

4) Disabling the Firewall

- ① Click 'Setting' on the right hand menu
- ② Click 'Control Panel'
- ③ Click 'Security'
- ④ Click 'Windows Firewall'
- ⑤ Click 'Turns Windows Firewall on or off' on the left
- ⑥ Click 'Off (not recommended),' and then click 'OK'

5) Run as Administrator

Windows 8 users must run the Installation File and Program as the Administrator

Install the program by right clicking (press and hold, if touch screen) and selecting 'Run as Administrator'

After completing the installation, set the icon, so that it always runs as administrator

- ① Right click (press and hold, if touch screen) the shortcut icon
- ② Click 'Properties'
- ③ Click the 'Advanced' icon in the 'Shortcut' tab'
- ④ Check the 'Run as administrator' box, click on 'OK'

7-1-3. Installation

Run the provided setup file.

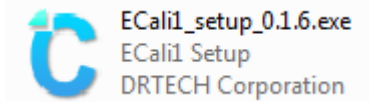

Figure 7.1. ECal11 Setup File

- ✓ At least 2GB of available HDD space is required for the proper installation of ECal11!
- ✓ Windows 8 users must run the file as 'administrator'.
 - Right-click the file, select 'Run as administrator' in the menu.

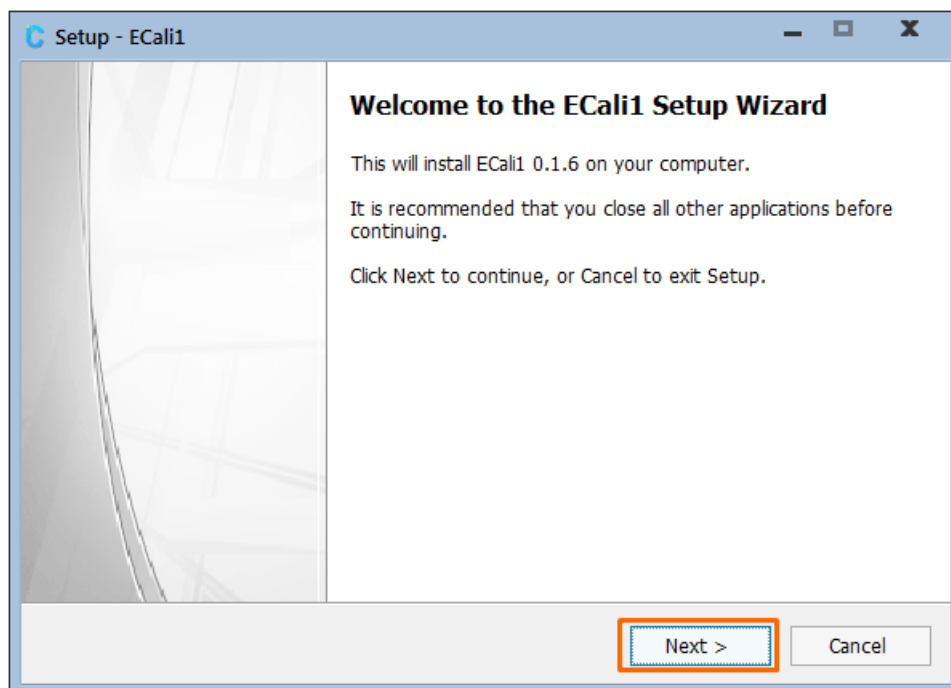

Figure 7.2. Setup Wizard Window

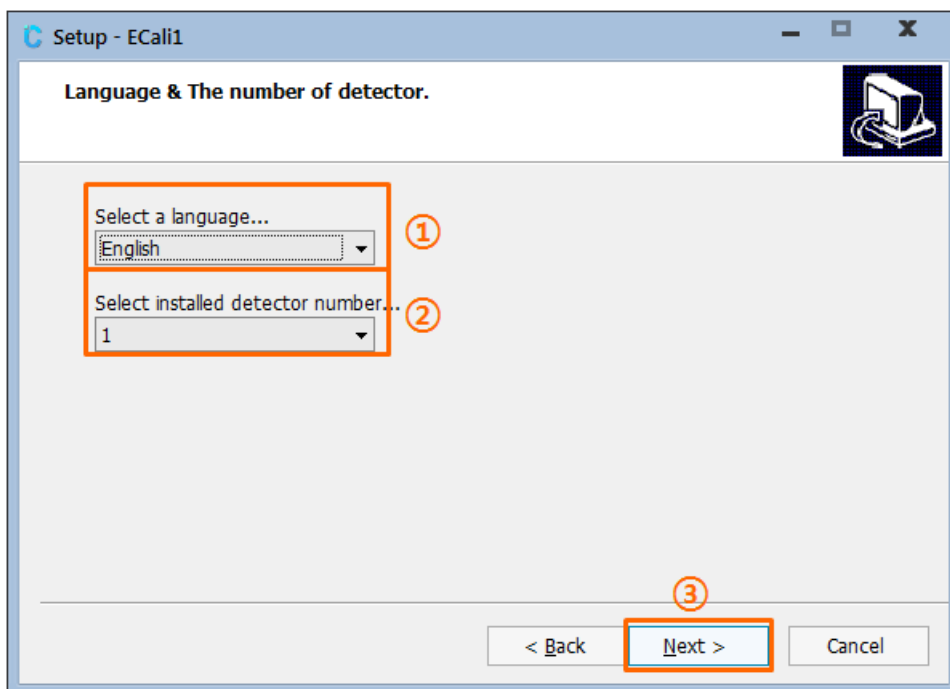

Figure7.3. ① Language & ② Number of Detector Setting

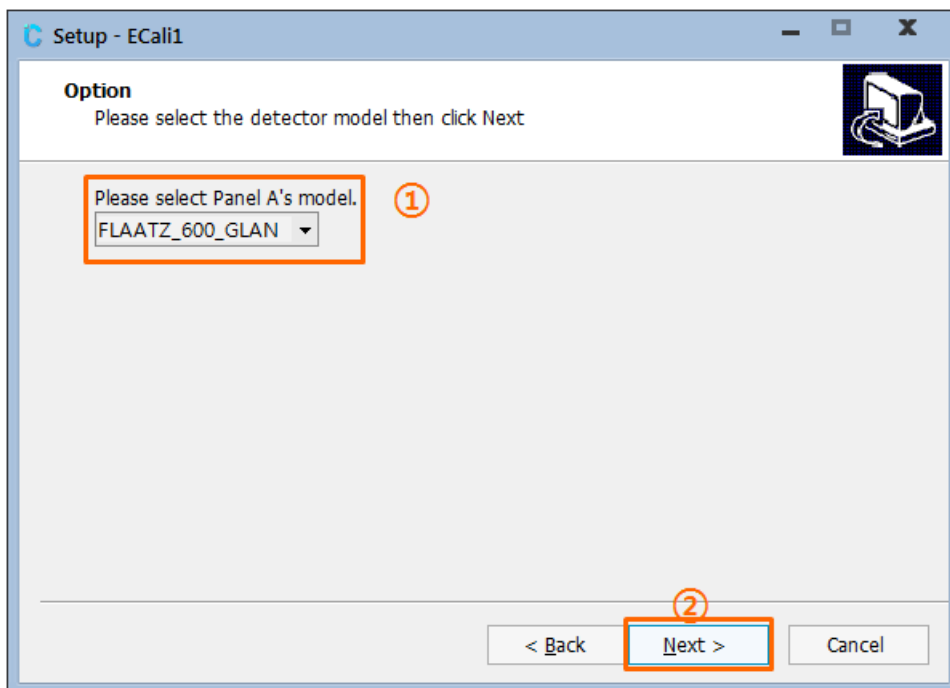

Figure7.4. Setting of the Model of the First Detector

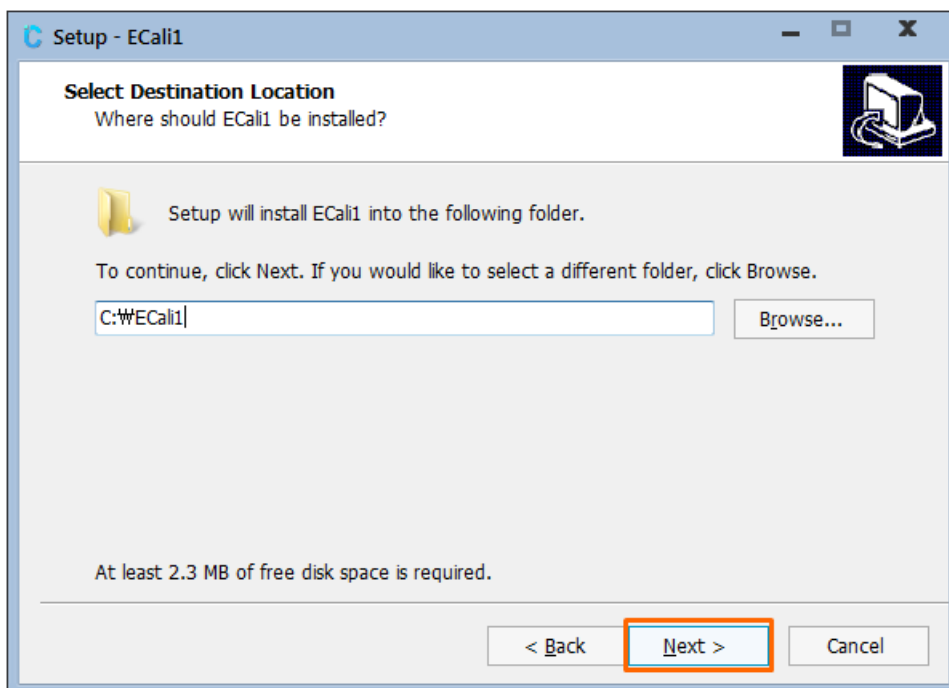

Figure7.5. Installation Path Setting

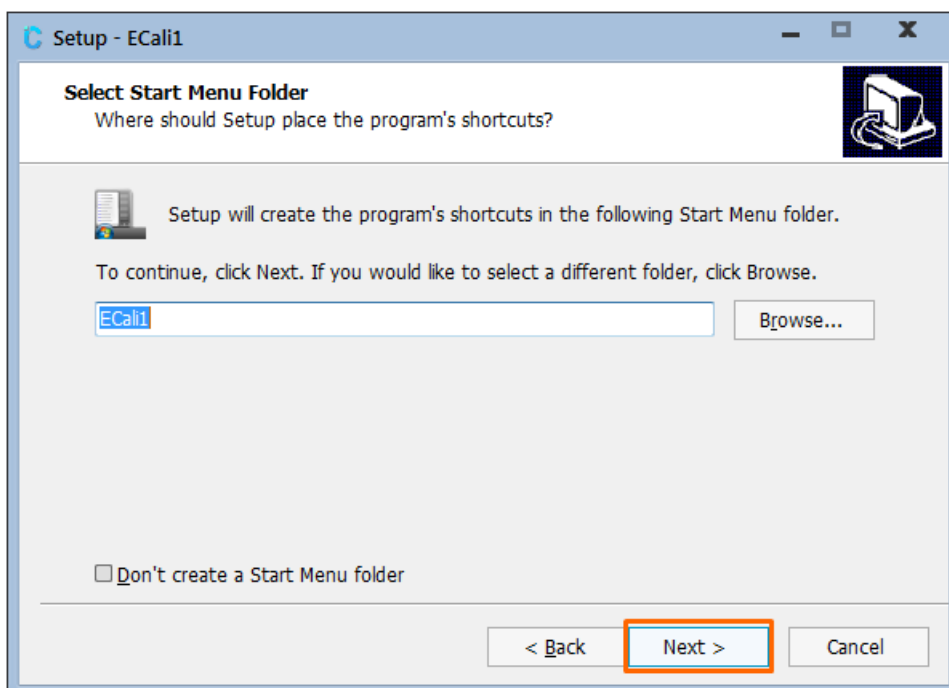

Figure 7.6. Start Menu Folder Selection

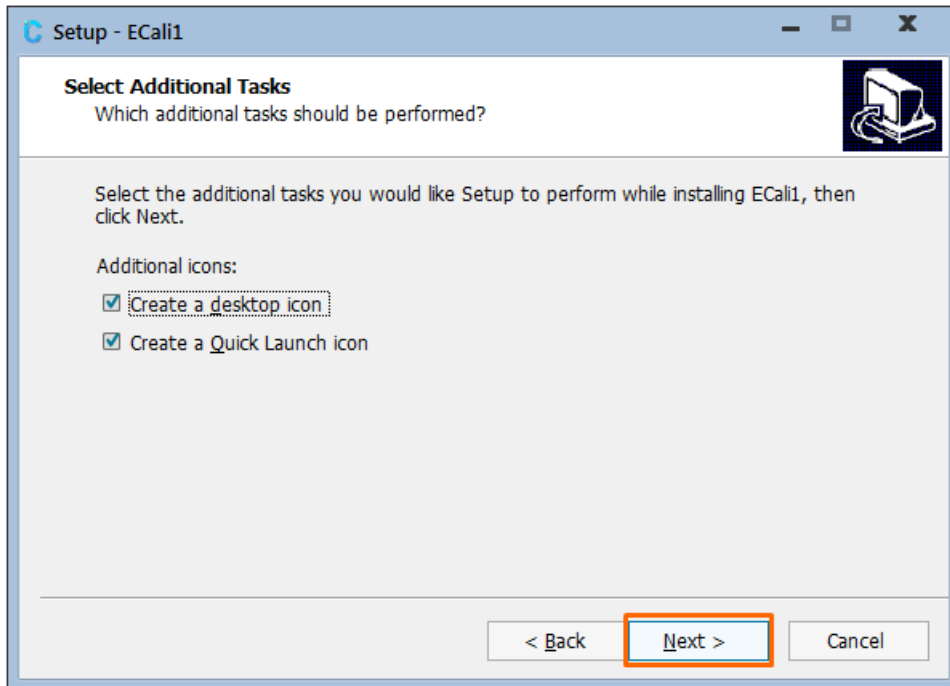

Figure 7.7. Additional Task Setting

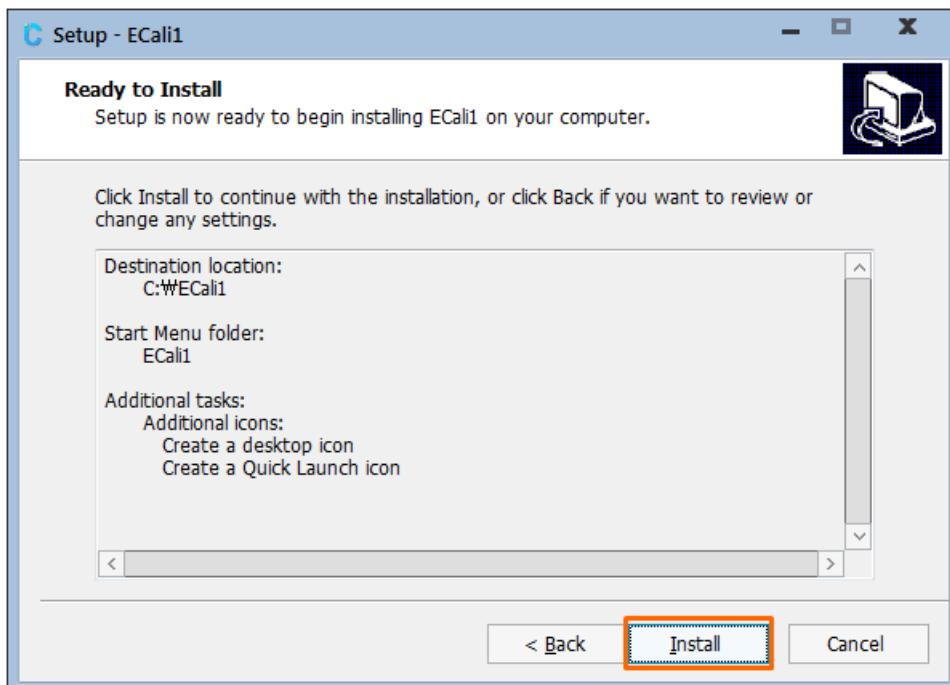

Figure 7.8. Verification of Settings

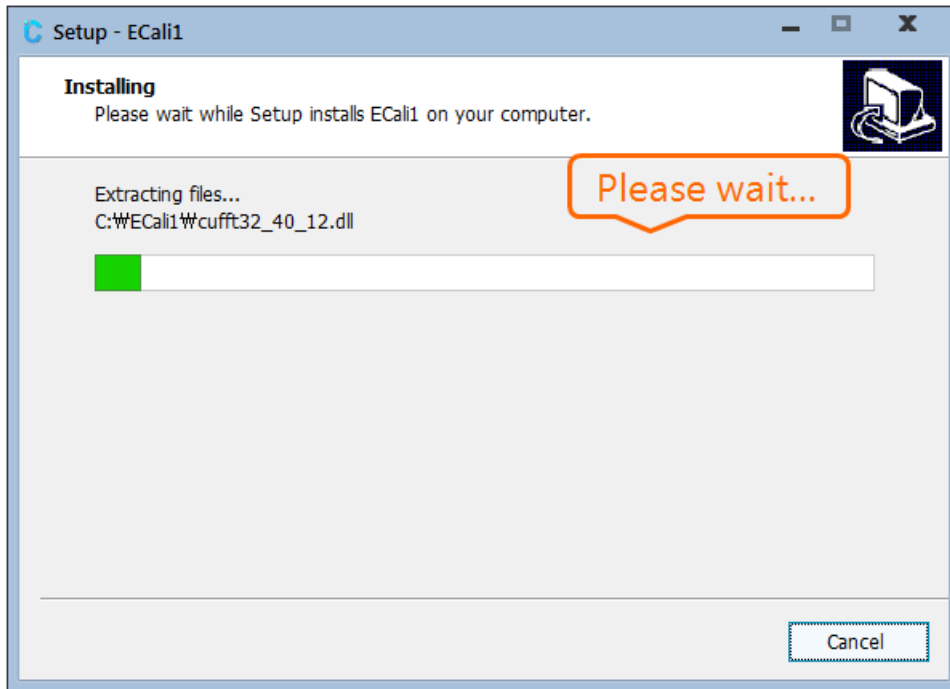

Figure 7.9. Installation Window

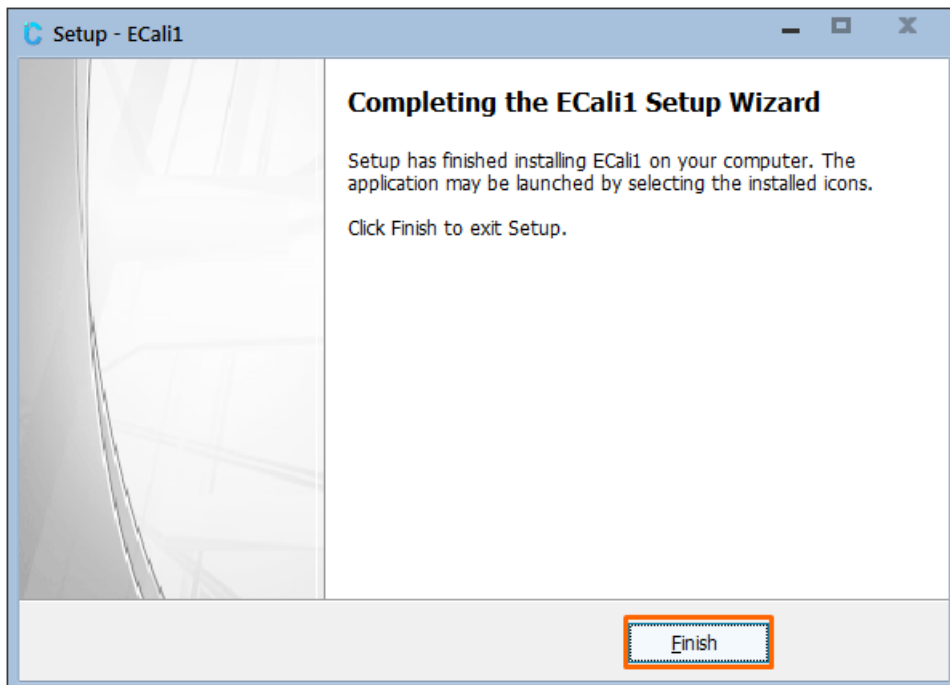

Figure 7.10. Installation Window

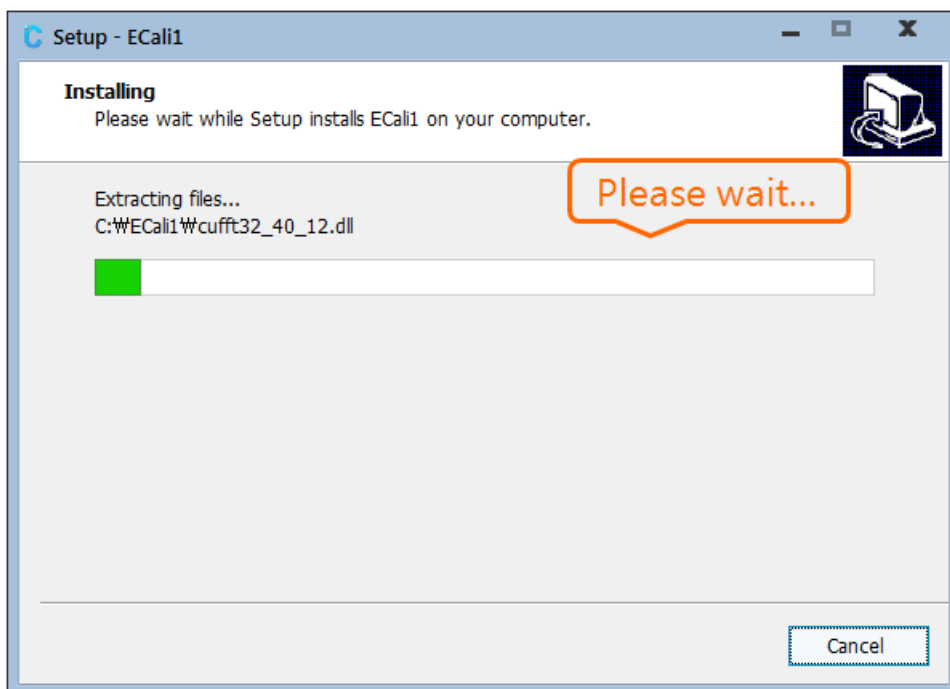

Figure 7.11. Installation Window

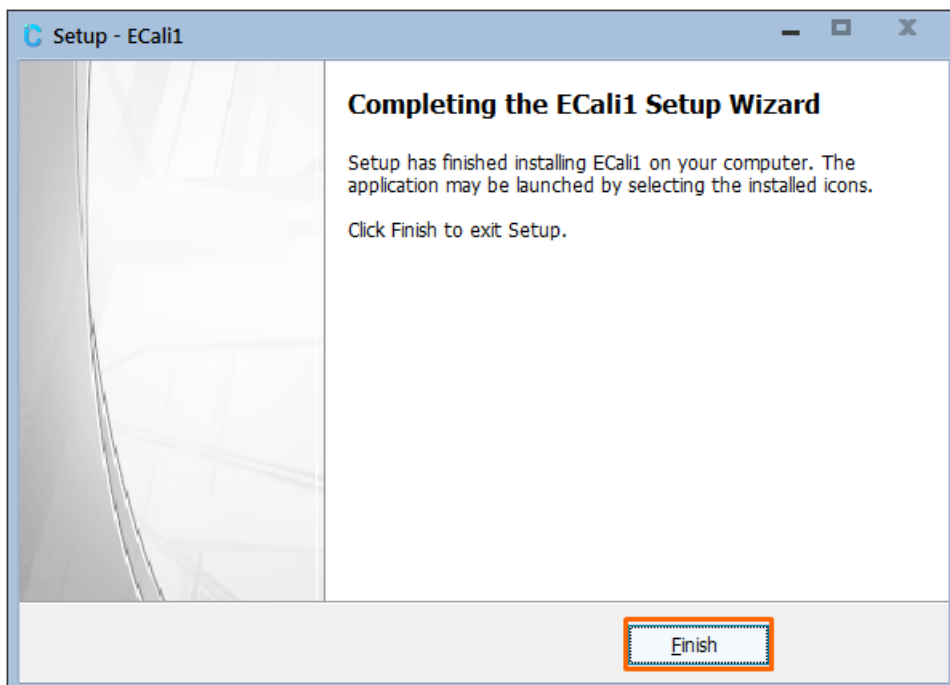

Figure 7.12. Installation Window

7-1-4 Settings Post Installation

1) Windows 8 users must set ECal1 so that it runs as administrator.

- ① Right click (press and hold) the 'ECal1.exe' in the installation destination (in C:\Cali1 by default).
- ② Click 'Properties'.
- ③ Select 'Advanced' in the 'Shortcut' tab.
- ④ Check the 'Run as administrator' box, then click 'OK'

7-1-5 IP Address Configuration

It is required when using a EVS 3643 detector using an Ethernet Interface.

The IP Address of the Network Adapter connected with the EVS 3643 Detector System installed on the PC should be configured.

For Windows 7, Control Panel – Network Connections – Network and Sharing Center – Manage Network Connections on the left menu bar – Right click on the network connected to the Detector – Properties – Double click Internet Protocol Version 4 (TCP/IPv4)

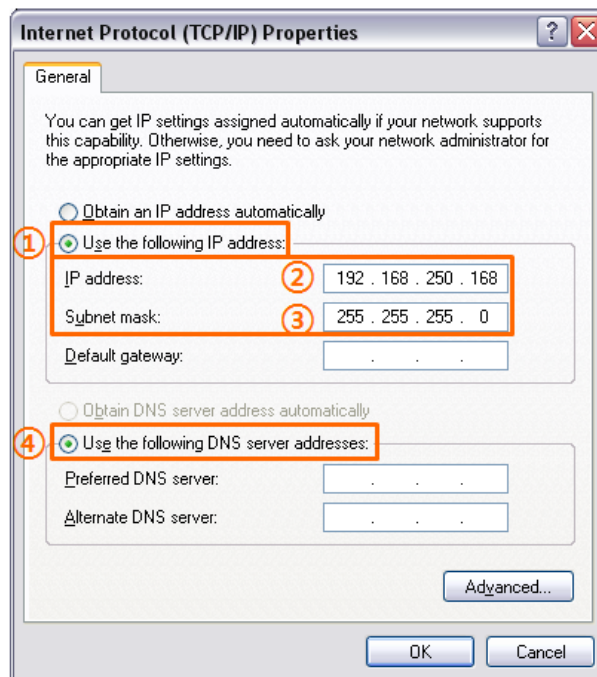

Figure7.13. IP Address Configuration

- ✓ ② IP Address: 192.168.250.XXX
 - For F600: 192.168.250.100
 - Others: 1 ≤ XXX ≤ 254 (Excluding 150 and 200)
- ✓ ③ Subnet mask: 255.255.255.0

7-1-6 Uninstall ECali1

- 1) Click 'Uninstall ECali1' in Windows start menu – All Programs - ECali1

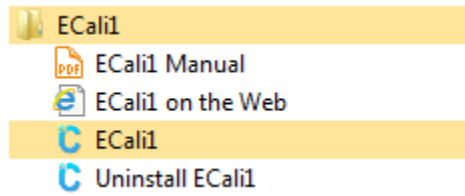

Figure 7.14. Uninstall ECali1

- 2) Click 'Yes' and proceed with uninstall when a window appears verifying the removal of the program.

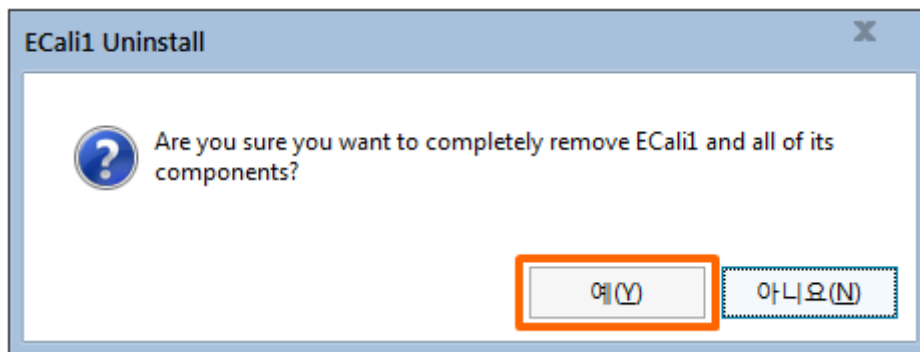

Figure 7.15. Uninstall ECali1

7-2 ECal1 Operation & Detector Integration

7-2-1 Program Start-up

In order to run the program, you can select ECal1 in Windows Menu – All Programs – ECal1 Folder, or by double clicking ECal1.exe in C:\ECali1 (or the customized installation path)

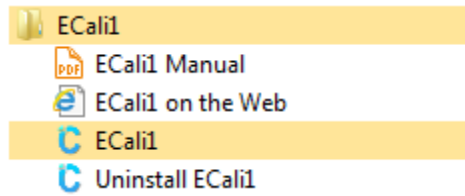

Figure 7.16. ECal1 Start-up

Note

- An error notification as in Figure 7.17. Pixel / Gain map File Notification) will be presented during the initial start-up of the program.
- It is a normal notification informing the absence of Pixel map file and Gain map file, so proceed by clicking 'OK'.



Figure 7.17. Pixel / Gain map File Notification

Note

Please install the additional software in accordance with the specification of your OS if the program does not operate after proper installation

For Windows XP SP3, Windows 7, and Windows 8:

- ✓ VC2008SP1 Runtime (vcredist_x86.exe)
- <http://www.microsoft.com/en-us/download/details.aspx?id=5582>

For Windows XP SP2:

- ✓ Wireless LAN API package
- <http://www.microsoft.com/en-us/download/details.aspx?id=2098>
- ✓ Microsoft Core XML Service (MSXML) 6.0
- <http://www.microsoft.com/en-us/download/details.aspx?id=3988>
- ✓ VC2008SP1 Runtime (vcredist_x86.exe)
- <http://www.microsoft.com/en-us/download/details.aspx?id=5582>

For Windows XP SP1 or earlier OS:

- ✓ ECali1 will only operate in Windows XP SP2 and later environments. Please install Service Pack 2 or 3 if you are using Windows XP.
- ✓ We do not guarantee proper operation of ECali1 in OS earlier than Windows XP

7-2-2 Detector Connection

- 1) The Detector which will be utilized should be registered prior to operating the program.
- 2) A Registration and Configuration window for the Detector will appear during the initial start-up of the program.
- 3) This configuration window is available through Configuration in the Option menu, and please refers to 1) Detector Configuration for detailed information.

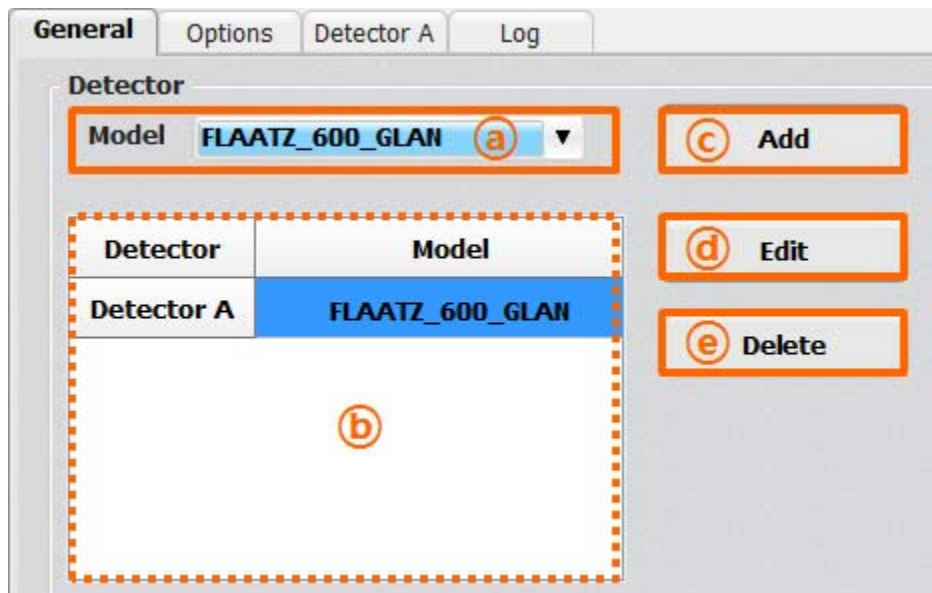
**Figure7.18. Detector Registration**

- ✓ ⑥ displays the registered Detector.
- ✓ If a specific item requires editing, select the Model to be edited in ① and click ④ Edit.
- ✓ Select a Model in ① and click ③ Add in order to add a Detector.
- ✓ The most recently registered model will be deleted if ⑤ Delete is selected.

- ✓ Changes in configurations must be saved.
- ✓ Save the changes in configuration by selecting the save icon below

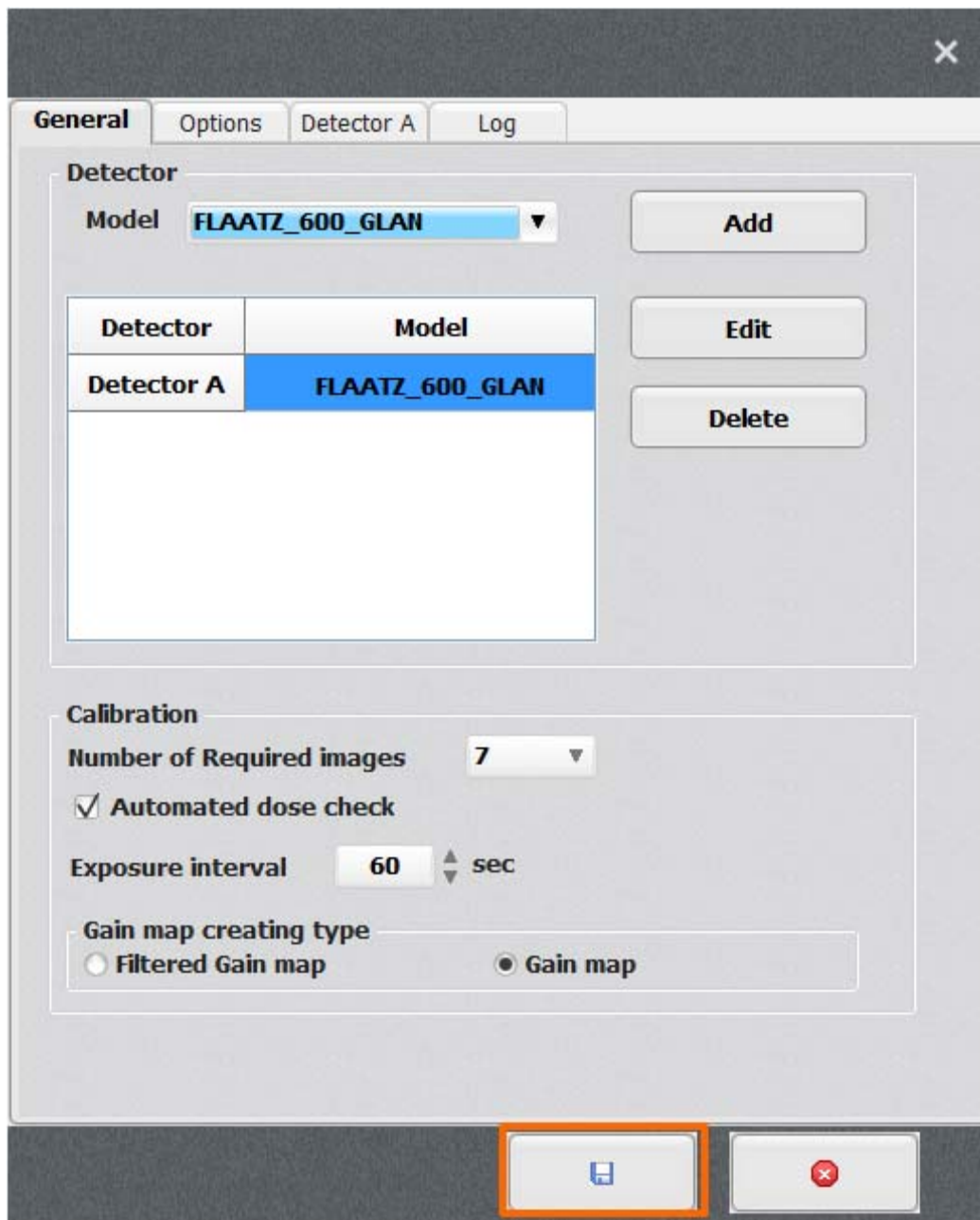

Figure 7.19. Configuration Save icon

- ✓ When the save button is selected, a program restart message will appear.
Restart the program by selecting 'OK'.

- ✓ Verify Detector Connection after restarting the program.
- ✓ Open the 'Log' tab after connecting and powering on all necessary devices including the Detector.

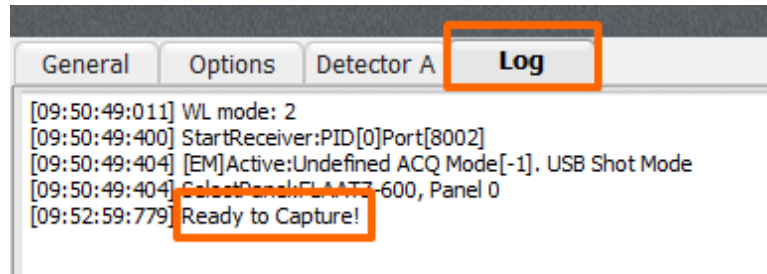

Figure7.20. Detector Connection Log

- ✓ The Detector has been successfully integrated if a 'Ready to Capture!' appears in the window as seen in the figure.

7-3 Grid Configuration

- 1) Grid type must be configured for each registered Detector..
- 2) The Grid type is set as 'None' by default, so this step may be skipped if a Grid isn't used.
- 3) Grid configuration may be completed in the 'Detector #' tab.
 # will be designated with alphabets of A, B, C,

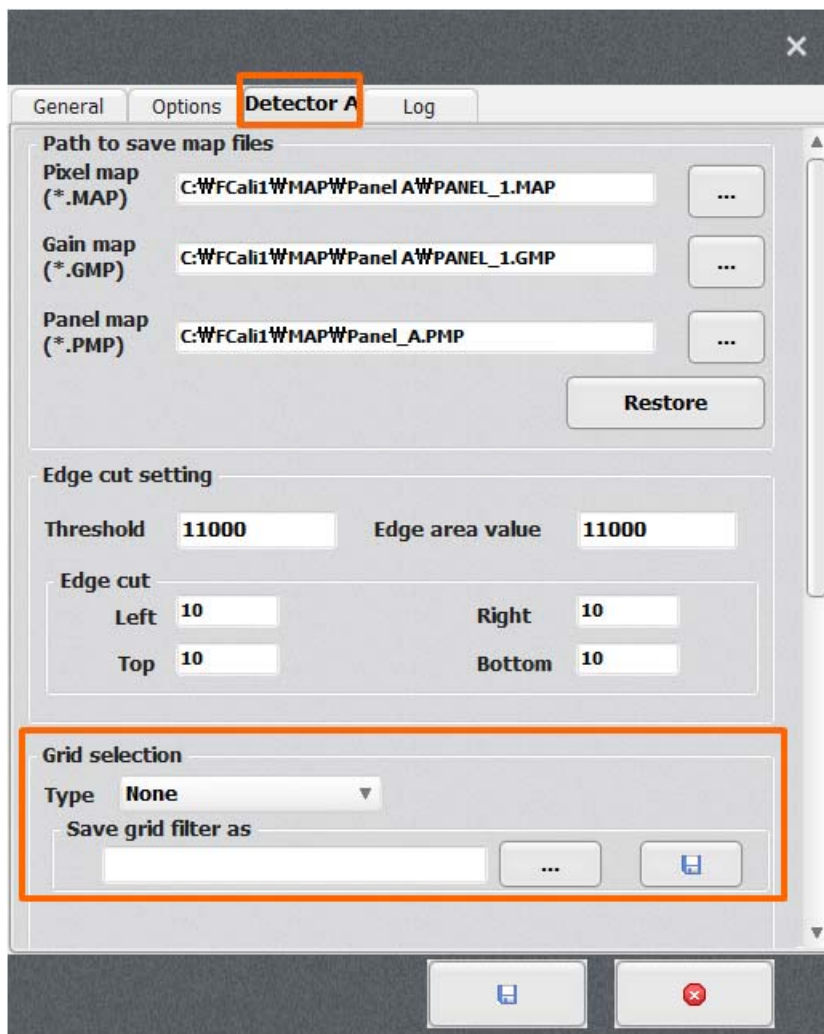

Figure 7.21. Grid Configuration

- 4) Please verify the Model and Grid of the registered Panel since a limited number of Detectors may use the Grid with the use of multiple Detectors.

5) Filter file must be registered after the configuration of Type.



Figure7.22. Registering Grid Filter File

- ① Select the Filter file by selecting ‘...’ as in the figure.
- ② A file compatible with the configured Grid Type must be selected.
- ③ Filter file is located in the [ECali1 Installation Folder]\Filter Folder.
- ④ It is in the C:\ECali1\FILTER folder by default.

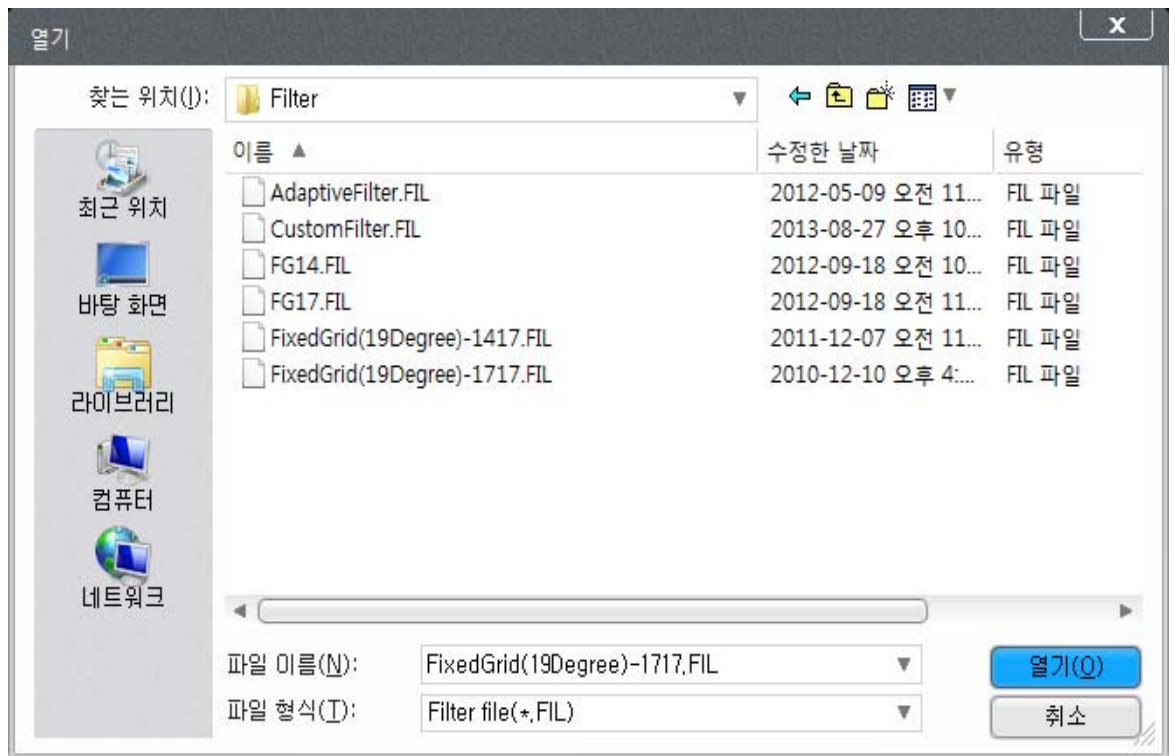

Figure 7.23. Filter File

6) Input the ㉠ Lines/Inch and ㉡ Angle in accordance with the Grid Type. The ㉢ cm to Inch button may be utilized to alter the units when entering the Lines/Inch, if the cm unit is known.

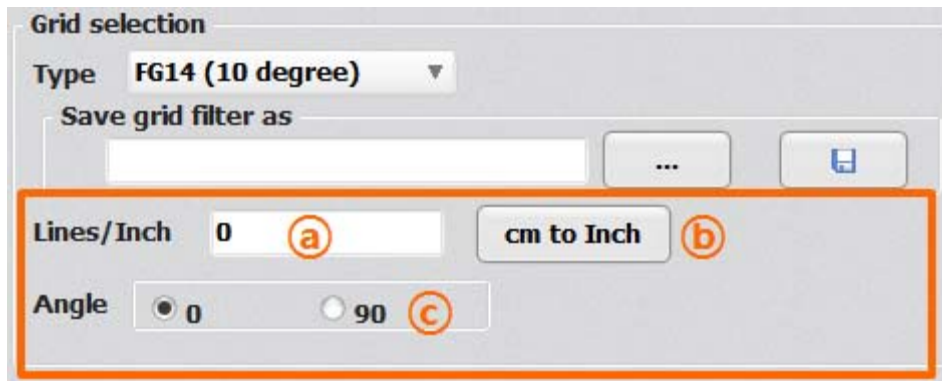

Figure7.24. Additional Grid Configuration

7) Save and restart the program after completing the configuration.

7-4 Map File Registration

Open the configuration tab for each registered Detector through Option Menu – configuration and opening the Configuration window.

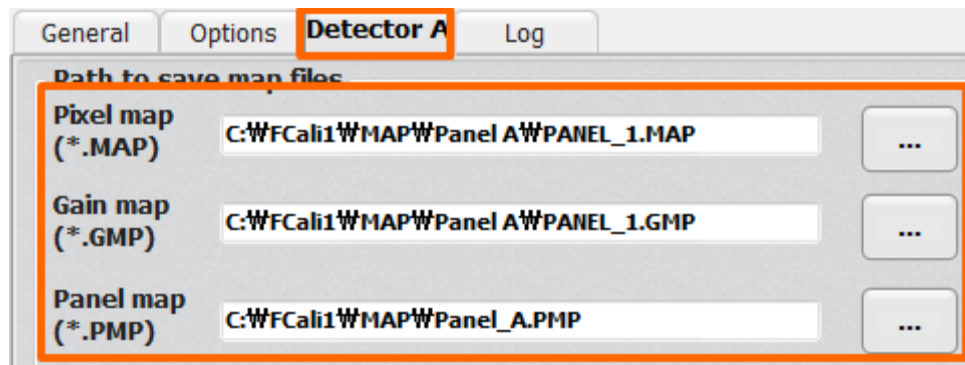

Figure7.25. MAP File Destination Configuration

Use the '...' on the right or manually enter in a new directory to change the destination name. **Please set it as a file used or provided by the X-ray acquisition software.**

Save the changes in configuration using the save button below after designating a destination for all registered Panels.



Figure7.26. Save Button

ECali1 will automatically restart when the changes in configuration has been saved.

7-5 ECali1 UI Overview

7-5-1 Main Screen of the Program

The main screen of ECali1 is as illustrated in [7.27].

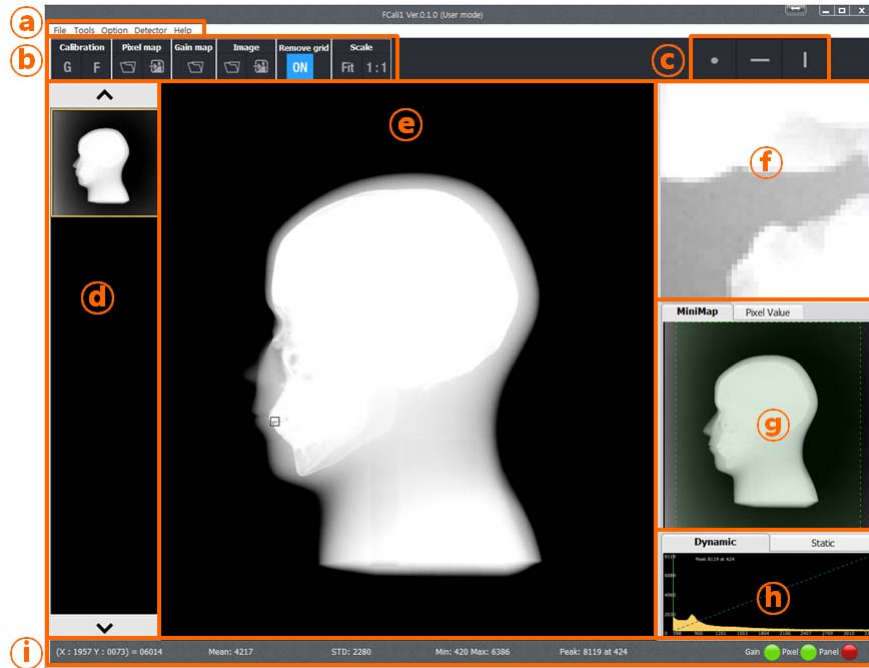

Figure 7.27. Main Screen of ECali1

Category	Title	Reference
(a)	Menu	Menu (p. 49)
(b)	Toolbar	Toolbar (p. 53)
(c)	Pixel Map Toolbar	Pixel Map Toolbar and Pixel Viewer (p. 66)
(d)	Thumbnail	Thumbnail (p. 67)
(e)	Image Viewer	Image Viewer (p. 68)
(f)	Pixel Viewer	Pixel Map Toolbar and Pixel Viewer (p. 66)
(g)	Mini Map / Pixel Value	7-7 Mini Map and Pixel Value (p. 70)
(h)	Histogram	Histogram (p. 71)
(i)	Status Bar	Status Bar (p. 72)

1) Menu

Corresponds to @ in [Figure 7.27] and comprised of 5 menus, which are File, Tools, Option, Detector and Help.

A. File Menu

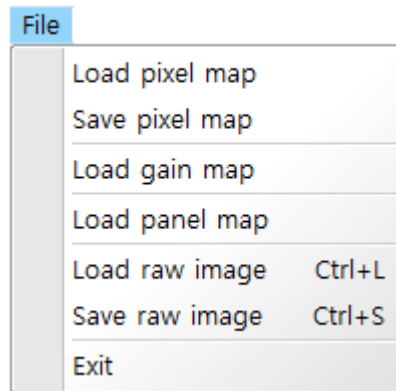

Figure 7.28. File Menu

Table 7.1. File Menu Descriptions

Menu	Descriptions
Load pixel map	Loads the Pixel map file.
Save pixel map	Saves the Pixel map file.
Load gain map	Loads the Gain map file.
Load panel map	Loads the Panel map file.
Load raw image	Loads the RAW image file in .IMG ¹ format.
Save raw image	Saves the currently selected image as a RAW image file in .IMG format.
Exit	Exits ECali1.

¹ .IMG file: Image Data file that has 16 bit gray-level pixel value
10-EVS1MADB001

B.Tools Menu

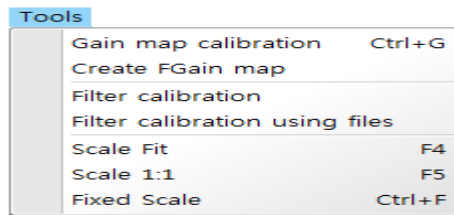

Figure 7.29. Tools Menu

Table 7.2. Tools Menu Descriptions

Menu	Descriptions
Gain map calibration	Initiates the Gain Map Calibration. Please refer to 7-10 Gain Calibration for more details.
Create FGain map	Generates a Filtered Gain Map ² using the currently loaded Gain Map. Will not operate if the loaded Gain Map is a Filtered Gain Map. The generated Filtered Gain Map is saved in the configured Gain Map destination of the Detector (Panel) set in Configuration.
Filter calibration	Run the Grid Filter Calibration task. Please refer to 오류! 참조 원본을 찾을 수 없습니다.. 오류! 참조 원본을 찾을 수 없습니다. for more details.
Filter calibration using files	Run the Grid Filter Calibration using raw files. Please refer to 오류! 참조 원본을 찾을 수 없습니다.. 오류! 참조 원본을 찾을 수 없습니다. for more details.
Scale Fit	Adjusts the magnifying ratio of the image displayed in the Image Viewer domain.
Scale 1:1	Adjusts the magnifying ratio of the image displayed in the Image Viewer domain to set the size of the image corresponding to its actual size. The Pixel displayed on the screen will be identical to the actual Pixel of the Detector.
Fixed Scale	Saves the configured scale ratio in the current Image Viewer and applies it to the subsequent images.

² Filtered Gain Map: Gain Map maintaining the uniformity of the image even if the uniformity of the X-ray source is different, by applying filtering to the Gain Map

C. Option Menu

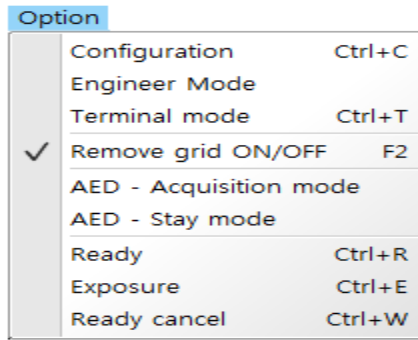

Figure 7.30. Option Menu

Table 7.3. Option Menu Descriptions

Menu	Descriptions
Configuration	Opens the Configuration window. Please refer to. 7-12 Configuration for more details regarding Configuration.
Engineer Mode	Initiates Engineer Mode of ECal1 for Advanced Configuration. Requires the input of a password.
Terminal Mode	Initiates the Terminal Emulator which allows the internal configuration of the Detector.
Remove grid ON/OFF	Sets the Grid Pattern Algorithm application. If a check mark (✓) is available as noted in the figure, the algorithm is applied (ON). This category must be ON if Grid is utilized.
AED – Acq mode	Activates AED mode to allow image acquisition.
AED – Stay mode	Inactivates AED mode and reverts to Standby.
Ready	Converts the status of the Detector to Ready.
Exposure	The Detector performs Exposure.
Ready cancel	Cancels the Ready status of the Detector and reverts to Standby.

D. Detector Menu

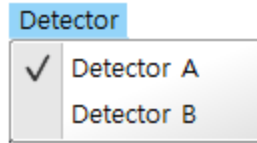

Figure 7.31. Detector Menu

- ① Select the active Detector from the registered Detector (Panel).
- ② Number of Menus reflecting the number of registered Detectors through Option – Configuration - General will be generated. Only one Detector may be selected

E. Help Menu

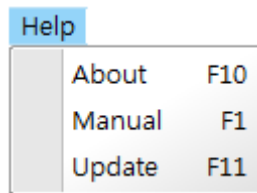

Figure7.32. Help Menu

Table 7.5. Help Menu Descriptions

Menu	Descriptions
Manual	Displays the ECali1 manual. The manual is in PDF format, thus Adobe Reader program will be required. http://get.adobe.com/kr/reader/
About	Will display the version information of ECali1.
Check update	* Requires internet connection. Checks and installs updates for ECali1.

7-5-2 Toolbar

Corresponds to ⑥ in [7.27] and provides most used menus as Toolbar icons.

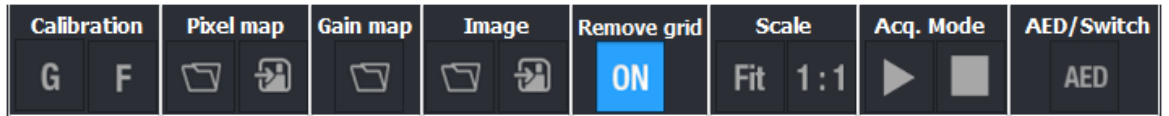
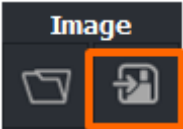
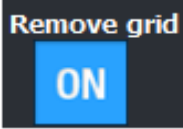
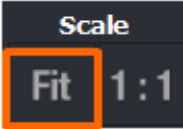

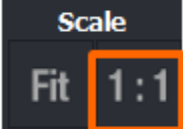

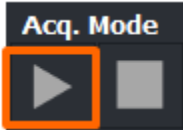
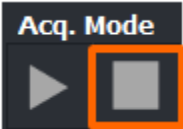



Figure 7.33. Toolbar

Table 7.6. Toolbar Icon Descriptions

Icon	Descriptions
	<p>Performs Gain map calibration. Corresponds to the Gain map calibration in the Tools Menu.</p>
	<p>Performs Grid Calibration. Corresponds to the Grid map calibration in the Tools Menu.</p>
	<p>Loads and applies the Pixel map file. Corresponds to the Load pixel map in the File Menu.</p>
	<p>Stores the currently applied Pixel map as a file. Corresponds to the Save pixel map in the File Menu.</p>
	<p>Loads and applies the Gain map file. Corresponds to the Load Gain map in the File Menu.</p>
	<p>Loads and displays the projected image from the file. Corresponds to the Load raw image in the File Menu.</p>

	<p>Stores the currently projected image as a file. Corresponds to the Save raw image in the File Menu.</p>
	<p>This category must be ON when using the Grid. Corresponds to the Remove grid ON/OFF in the Tools Menu.</p>
	<p>Adjusts the magnifying ratio of the image in  to fit on screen. Corresponds to the Scale Fit in the Tools Menu.</p>
	<p>Adjusts the magnifying ratio of the image in  to actual size of the image. Corresponds to the Scale 1:1 in the Tools Menu.</p>
	<p><i>* Only available when the selected Detector (Panel) supports AED mode.</i> * Only available when AED mode is active. Changes the status of the Detector to acquire images. Corresponds to the AED - Acq mode in the Options Menu.</p>
	<p><i>* Only available when the selected Detector (Panel) supports AED mode.</i> * Only available when AED mode is active. Converts the Detector to Standby mode. Corresponds to the AED - Stay mode in the Options Menu.</p>
	<p><i>* Only available when the selected Detector (Panel) supports AED mode.</i> This category must be activated when using AED mode.</p>

7-5-3 Pixel Map Toolbar and Pixel Viewer

Corresponds to © and ƒ in [Figure 7.27], and utilized when creating a Pixel Map.

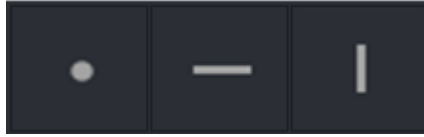

Figure7.34. Pixel Map Toolbar



Figure 7.35. Pixel Viewer

The selected area from the Image Viewer will be magnified and displayed in the Pixel Viewer. Please refer to 7-11 Pixel Correction for more details and methods of generating Pixel Maps.

7-5-4 Thumbnail

Corresponds to ④ in [Figure 7.27].



Figure 1.36. Thumbnail

Displays the Thumbnail of the projected image, and allows the user to select a specific image between multiple images.

If there are a significant number of projected images, a scroll button on the top and bottom allows the user to select a specific image.

Select the Thumbnail to be deleted and select 'Delete' if a re-projection is required during the calibration. The selected image will be deleted and a re-projection may be performed.

The following information will be displayed if an image is loaded from a file.

- ◆ The file name will be displayed on the top left.
- ◆ STD: Standard Deviation Value of the Pixel value of the image.
- ◆ Mean: Mean value of the pixel value of the image.



Figure 7.37. Thumbnail Information

7-6 Image Viewer

Corresponds to © in [Figure 7.27].

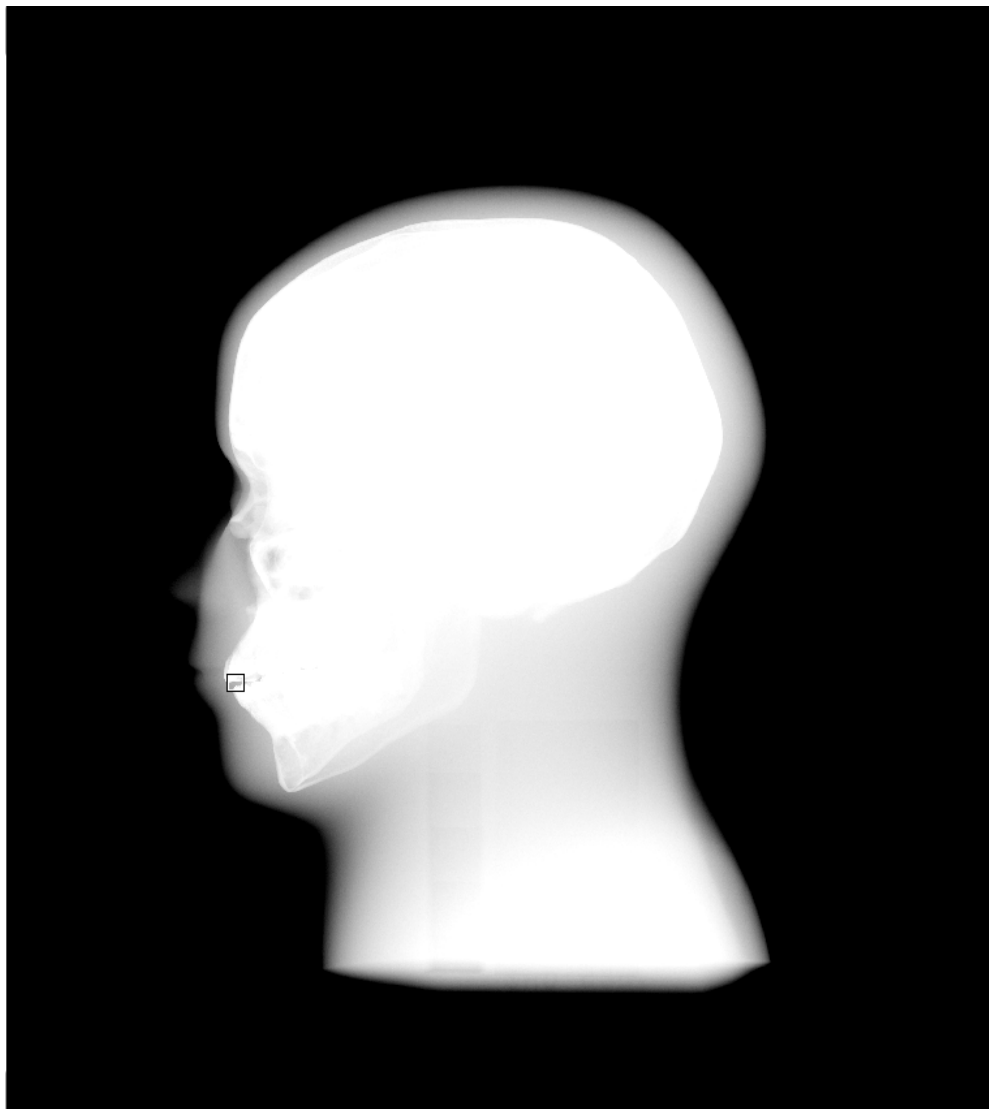

Figure 7.38. Image Viewer

Displays the projected image and supports the following functions.

Table 7.7. Image Viewer Function & Control Method

Function	Control Method
Magnify	Roll the mouse wheel forward in the Image Viewer.
Reduce	Roll the mouse wheel backwards in the Image Viewer.
Move Image	Left click, drag and drop the image in the Image Viewer.
W/L ³ Width Increase	Drag the right mouse button down.
W/L Width Reduction	Drag the right mouse button up.
W/L Left Shift	Drag the right mouse button left.
W/L Right Shift	Drag the right mouse button right.
Magnify Pixel	Double click the left mouse button in the area within the Image Viewer in order to magnify the selected are in the Pixel Viewer screen.

³ W/L: Window Leveling

7-7 Mini Map and Pixel Value

Corresponds to @ in [Figure 7.27]

7-7-1 Mini Map

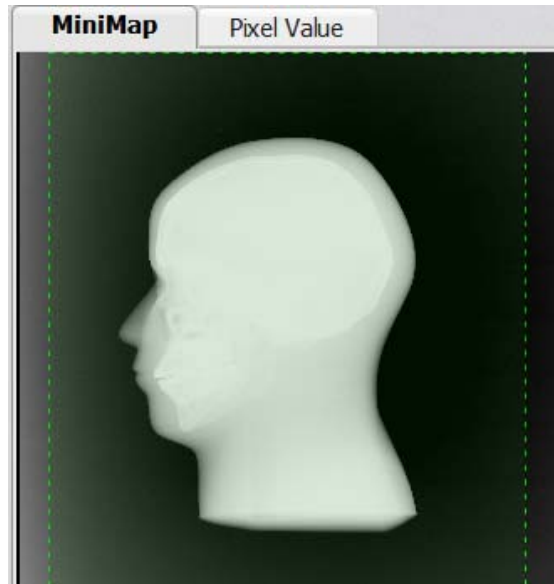

Figure 7.39. Mini Map

Allows the users to verify the area currently being viewed in the Image Viewer. The area within the green dotted boarder is the area currently displayed in the Image Viewer.

7-7-2 Pixel Value



Figure 7.40. Pixel Value

Displays the pixel value of the location the mouse cursor is hovering in the Image Viewer or the Pixel Viewer.

7-8 Histogram

Corresponds to  in [Figure 7.24]

Displays the Histogram of the selected image

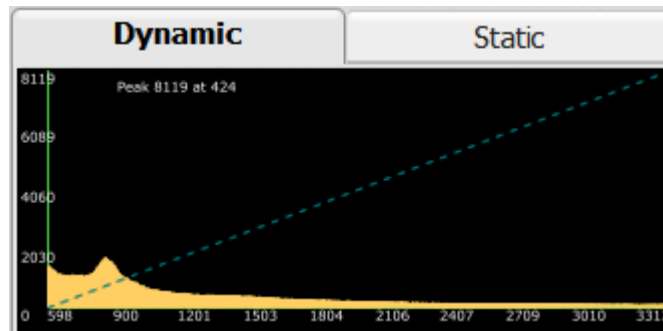

Figure7.41. Histogram

Supports Dynamic or Static mode subsequent to the Windows Leveling conditions

7-8-1 Dynamic

The minimum and maximum values will be fixed while the Histogram values may be adjusted if Window Leveling is attempted in the Image Viewer while in Dynamic mode.

7-8-2 Static

The Histogram values will be fixed while the minimum and maximum values may be adjusted if Window Leveling is attempted in the Image Viewer while in Static mode.

7-9 Status Bar

Corresponds to ① in [Figure 7.27]



Figure7.42. Status Bar

7-9-1 Image Information Display



Displays various information of the image

- ① Current axis and Pixel value of the mouse cursor
 - Displayed as (X : [X Axis] Y : [Y Axis]) = [Pixel Value]
- ② Mean: Mean Pixel Value of the image
- ③ STD: Standard Deviation of the Pixel value of the image
- ④ Min: Minimum value of the image Histogram
- ⑤ Max: Maximum value of the image Histogram
- ⑥ Peak: The Peak value and its Position of the image Histogram
 - Displayed as [Peak Value] at [Position]

7-9-2 Detector Status Display

*** Supports only Ethernet Type and F600.**



A green light will be displayed if the Detector is able to take a projection and a red light will be displayed if the Detector is unable to take a projection.

7-9-3 Wireless Information Display

* Support only Wireless Detector.



Information displayed when using a Wireless data communication.

7-9-4. Map File Loading Display



Green light will be displayed if a Map file required for Calibration has been loaded and the red light will be displayed if it has not been loaded.

- ✓ Gain: Gain Map Loading
- ✓ Pixel: Pixel Map Loading
- ✓ Panel: Panel Map Loading

If a Filtered Gain Map has been loaded in place of a Gain Map, the following FGain will be displayed.

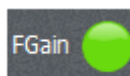

7-10 Gain Calibration

Gain Calibration Procedure will update or modify the x-ray characteristics to be combined at the field to enhance the acquired image quality.

7-10-1 Gain Calibration Preparation

1)Detector and Grid Configuration

The Detector and Grid configuration must be completed prior to performing Gain Calibration. Please refer to for details pertaining to the configuration.

2)MAP Data Location Configuration

The provided Pixel Map (*.MAP) and Gain Map (*.GMP) should be Loaded prior to performing Gain Calibration. The destination location of the Map file provided by the X-ray image acquisition software (EConsole1 and etc.) should be registered in configuration.

Please refer to
7-4 Map File Registration for more details

7-10-2 Gain Calibration

Actual X-ray must be shot to project an image in order to perform Gain Calibration.

The Gain Calibration projection conditions are as follows. [Table 7-8]

Table 7.8. Gain Calibration Condition

Conditions	Descriptions
Grid application	Projection must be taken without the application of Grid. (Cautions) The Grid Type must be set 'None' in Configuration - Detector - Grid selection - Type before Gain Calibration, and must be restored after Gain Calibration.
Subject	Projection must be done without a subject
X-ray exposure	X-ray exposure is required
X-ray radiation dose	Adjust the mean pixel value of the projected image to be between 3,000 ~ 4,000 X-ray Condition example) 70kVp, 200mA, 2mAs
SID	Stand: 150 cm, Table: 100 cm
Number of projections	Default Value: 7 counts Configuration possible in Configuration - General - Calibration - Count.
Projection interval	Default Value: 60 Seconds Configuration possible in Configuration - General - Calibration - Interval.
Other things	Collimator should be open maximally X-ray should be set to be exposed in the whole Detector Detector should be aligned in the center

1) Detector Selection

Select the Detector to perform the Gain Calibration from the Detector Menu.

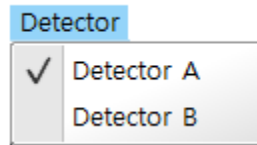

Figure 7.43. Detector Selection

2) Starting Gain Map Calibration

Next, select Gain map calibration from Tools Menu or select the shortcut icon.

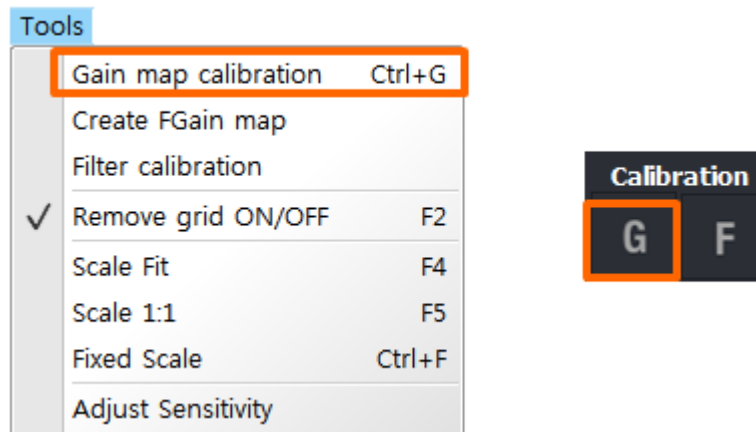

Figure7.44. Starting Gain Calibration

A notification message will appear. Select 'OK'.

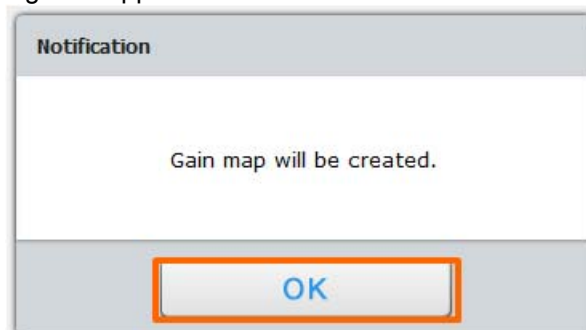

Figure 7.45.. Gain Calibration Start Notification

Next, ECal1 alerts whether the radiation dose is appropriate or whether it should be automatically calculated. Proceed by selecting 'OK'.

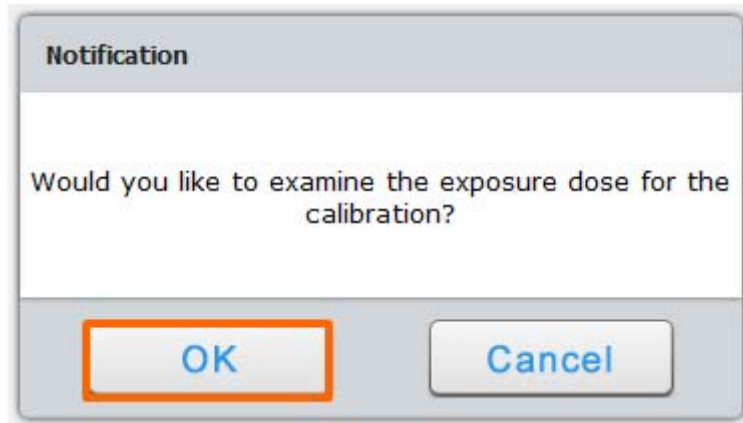

Figure 2. X-ray Radiation Dose Check Activation

Next, a main screen will appear. Proceed with the X-ray projection at this point in order to acquire an image.

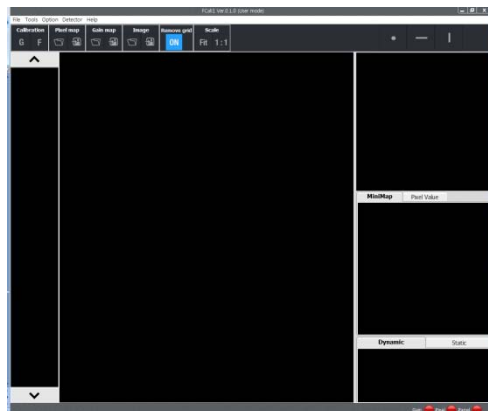

Figure 7.473. Projection Standby Main Screen

The program automatically determines the appropriateness of the X-ray radiation dose when the image is acquired.

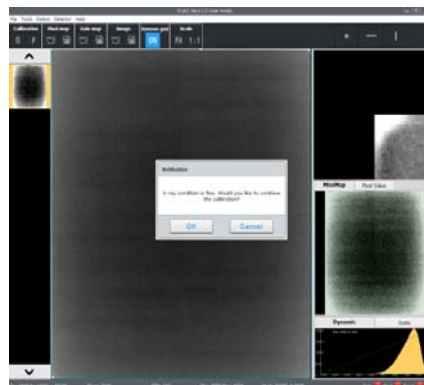

Figure7.48. X-ray Radiation Dose Verification Notification

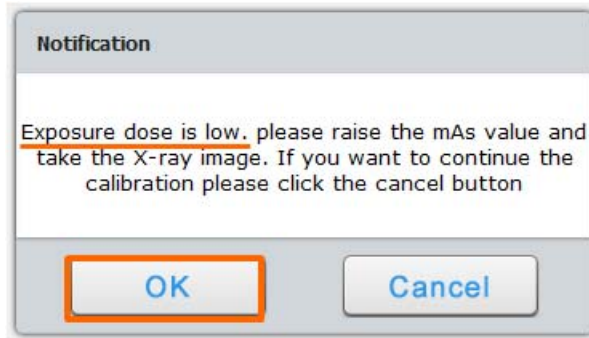

Figure7.49. Notification for Low X-ray Radiation Dose

If provided with a notification of low radiation dose, please select 'OK' then increase the X-ray radiation dose and re-project.

A notification will also appear if the X-ray radiation dose is high. Please select 'OK' then reduce the X ray radiation dose and re-project.

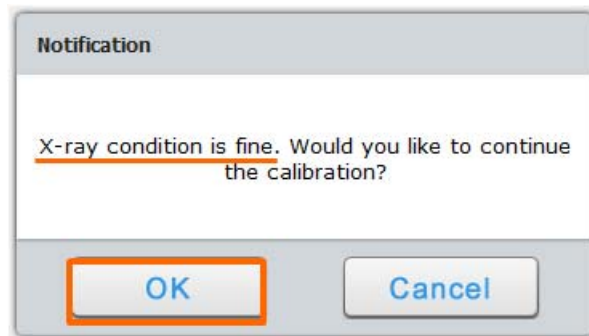

Figure 7.50. Notification for Appropriate X-ray Radiation Dose

If the X-ray radiation dose is appropriate, please select 'OK' and proceed with the projections.

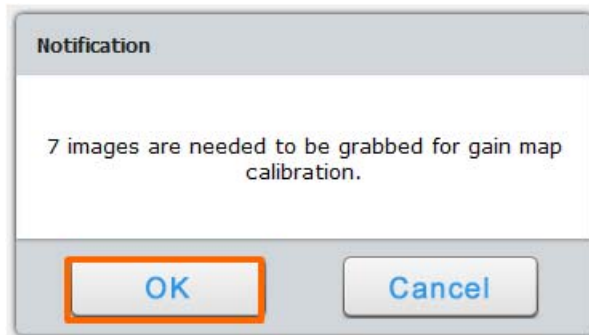

Figure 7.51. Notification Informing 7 Images Requirement

A notification informing the requirement of 7 images will appear. The required number of images may be set in Configuration.

Select 'OK' and proceed with the projections of 7 images.

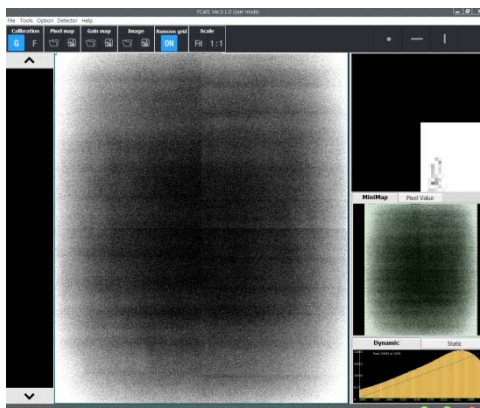

Figure 7.52. Starting the Gain Calibration Projection

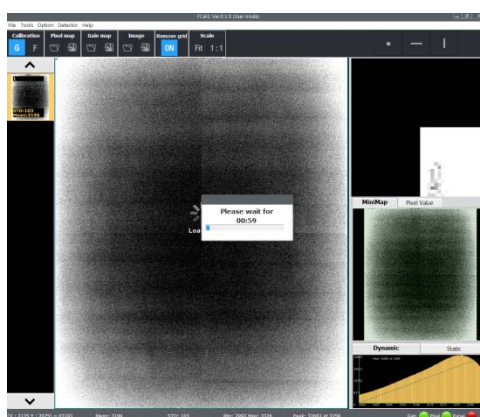

Figure 7.53. Standby post Projection of 1 Image

Stand by until the next designated projection after the initial projection.

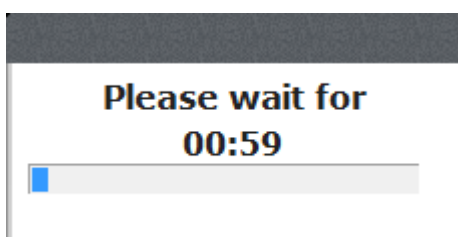

Figure 7.54. Projection Standby Timer

The next projection will take place after the projection standby timer disappears. The projection standby time may be set in configuration.

The Gain Calibration results are automatically saved as Gain Map (*.GMP) when all required images are projected and the existing files are backed-up.

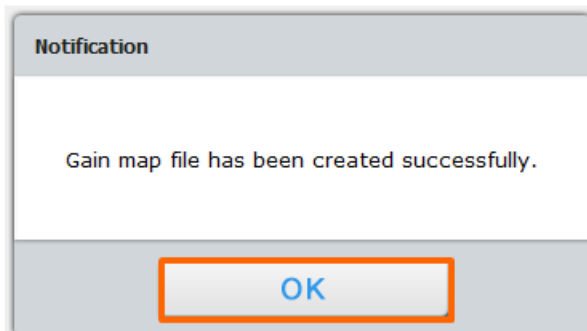

Figure7.55. Notification for Gain Calibration Completion

The existing GMP files are backed up in the [ECali1 Installation Folder]\MAP folder. The file name is as follows. [7-56]

 Panel APANEL_1_20130829140147.GMP

Figure7.56. Example of a Back-up File

7-11 Pixel Correction

If there are pixel defects or line defects needed to be calibrated, users can correct them manually.

7-11-1 Pixel Correction Preparation

1) Detector and Grid Configuration

The Detector and Grid configuration must be completed prior to performing Pixel correction

2)Map Data Location Configuration

The provided Pixel Map (*.MAP) should be Loaded prior to performing Pixel Correction.

The destination location of the Map file provided by the X-ray image acquisition

Software (EConsole1 and etc.) should be registered in Configuration.

7-11-2 Pixel Correction Performance

At least 1 count of RAW image acquired through X-ray Exposure is required to perform Pixel Correction.

Table 7.4. Pixel Correction Conditions

Condition	Descriptions
Grid application	Projection must be taken without the application of Grid
Subject	Projection must be done without a subject
X-ray exposure	X-ray exposure is required
Number of projection	More than 1 count. (One for check and correct defects, and others to verify correction)
Other things	Collimator should be open

1) Detector Selection

Select the Detector to perform the Pixel Correction from the Detector Menu.

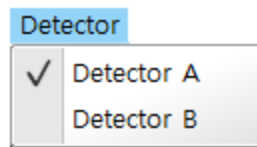

Figure 7.56. Panel Selection

2) Pixel Correction

Acquire the image by performing an X-ray projection from the main screen.

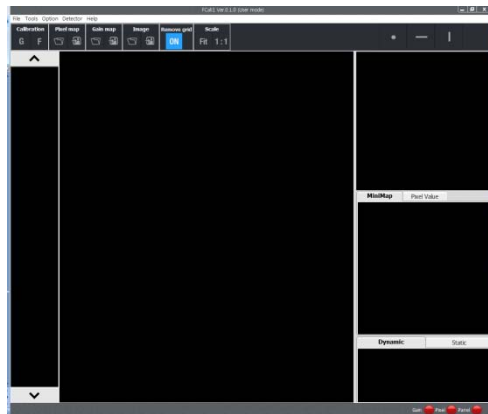

Figure 7.57. Projection Standby Screen

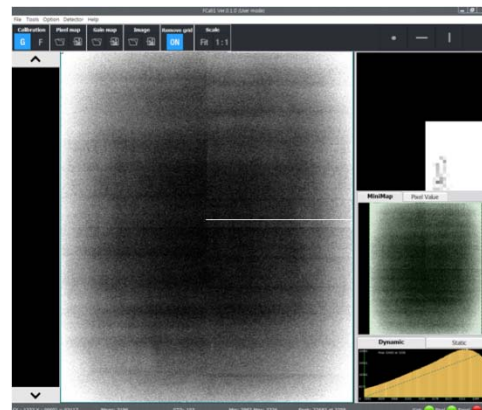

Figure 7.58. Image Acquisition Screen post Projection

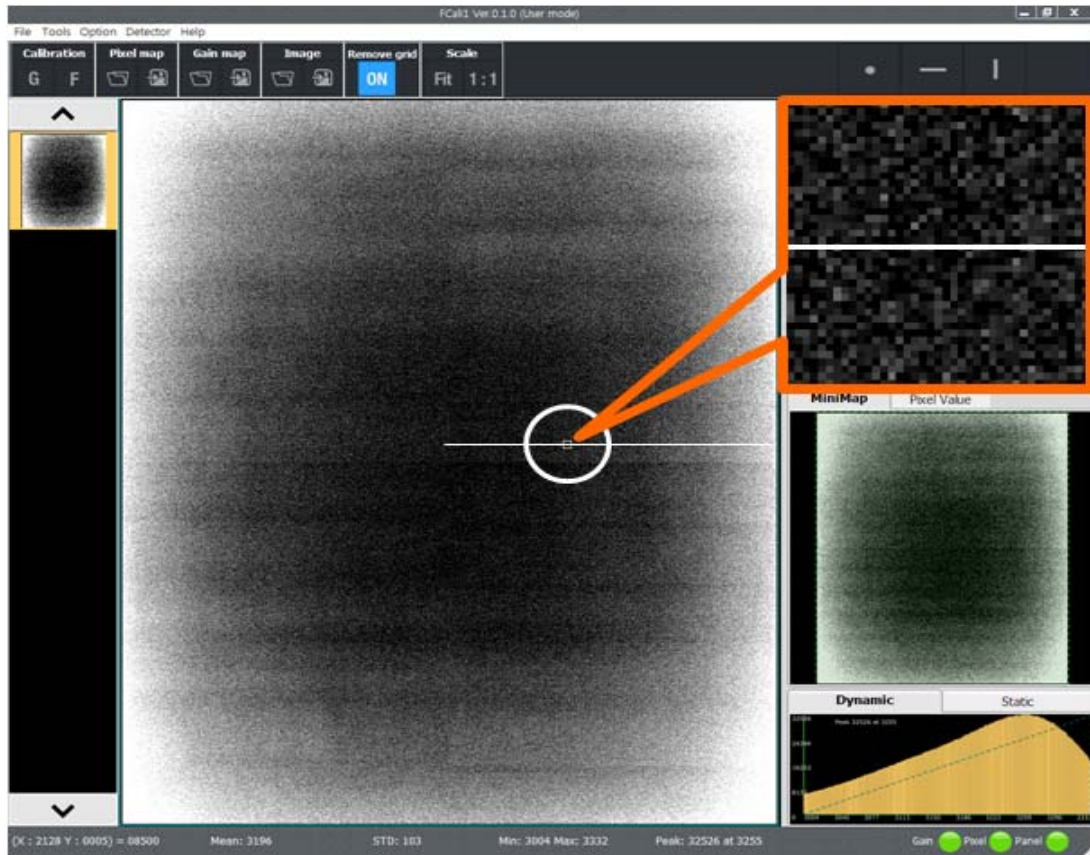

Figure 7.59. Display the Horizontal Line Defect Area in Pixel Viewer

A defect of a point or line may exist for each Detector. [7-59] illustrates a Horizontal Line Defect.

There are 3 types for Pixel Correction.

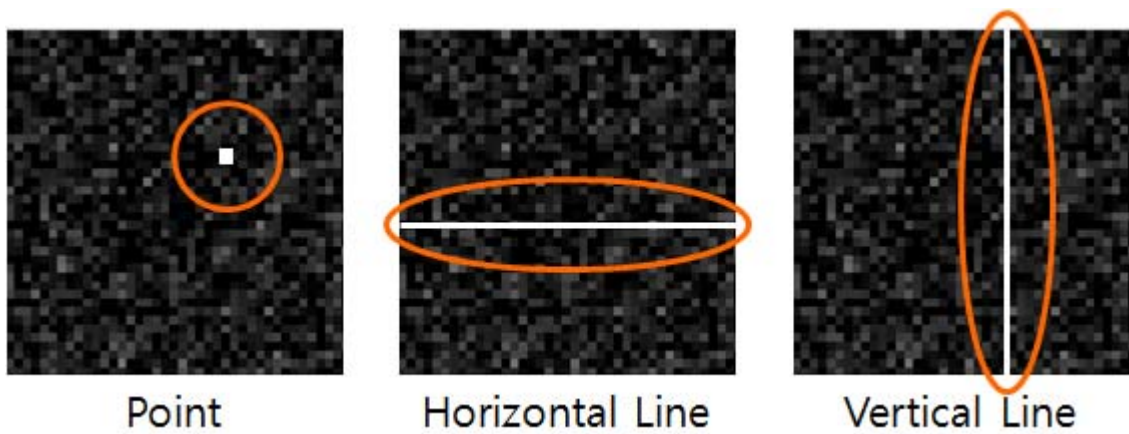

Figure 7.60. Pixel Defects

The following are utilized to perform Pixel Correction. [Figure7-61]



Figure 7.61. Pixel Correction Icon

Pixel Correction is performed in the following process.

- ① Display the Pixel Defect in the Pixel Viewer
- ② Select the appropriate shortcut icon
- ③ Ctrl+Left Click the area of Defect in the Pixel Viewer

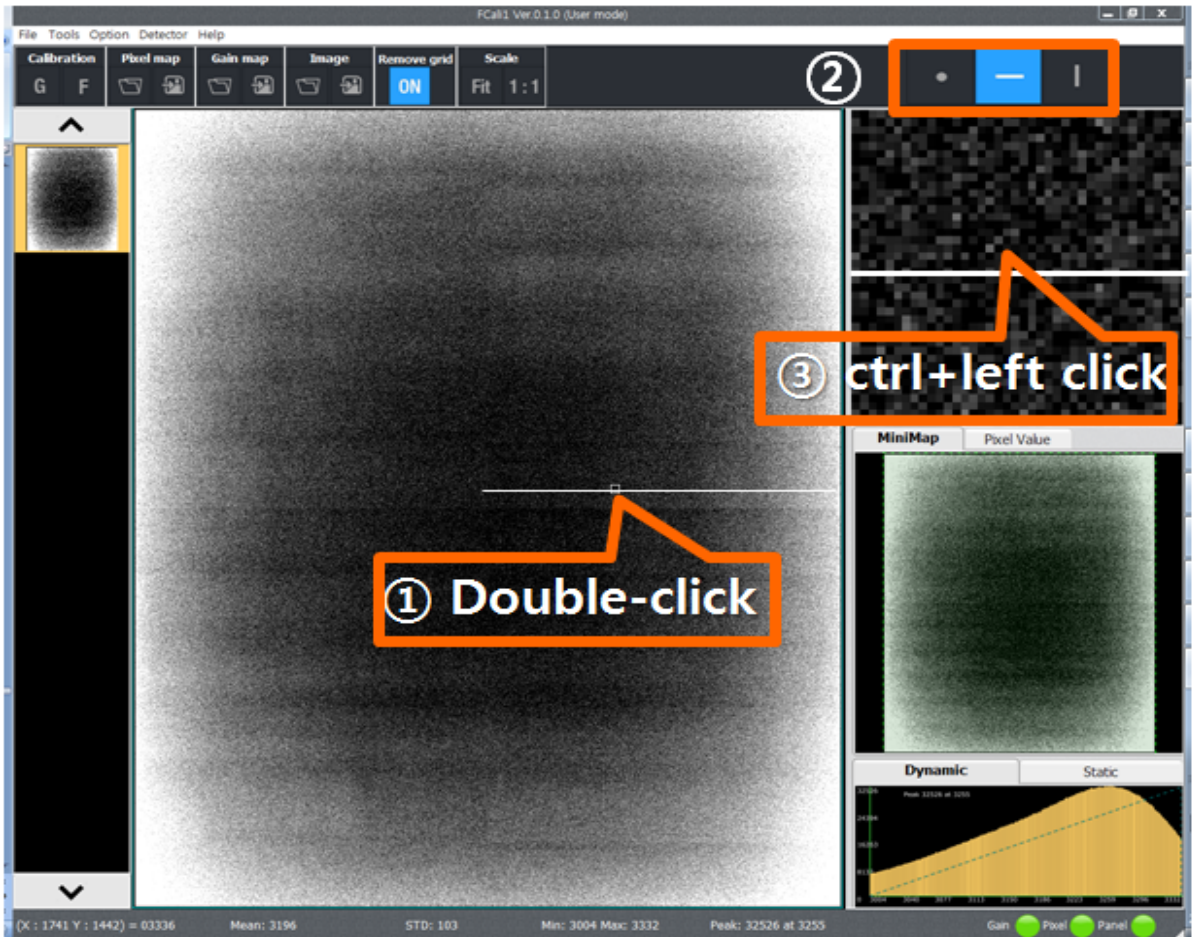

Figure 7.62. Pixel Correction (Horizontal Line Defect)

The selected Defect will be displayed in green.

The selected Defect will be displayed in blue if the Defect is already saved.

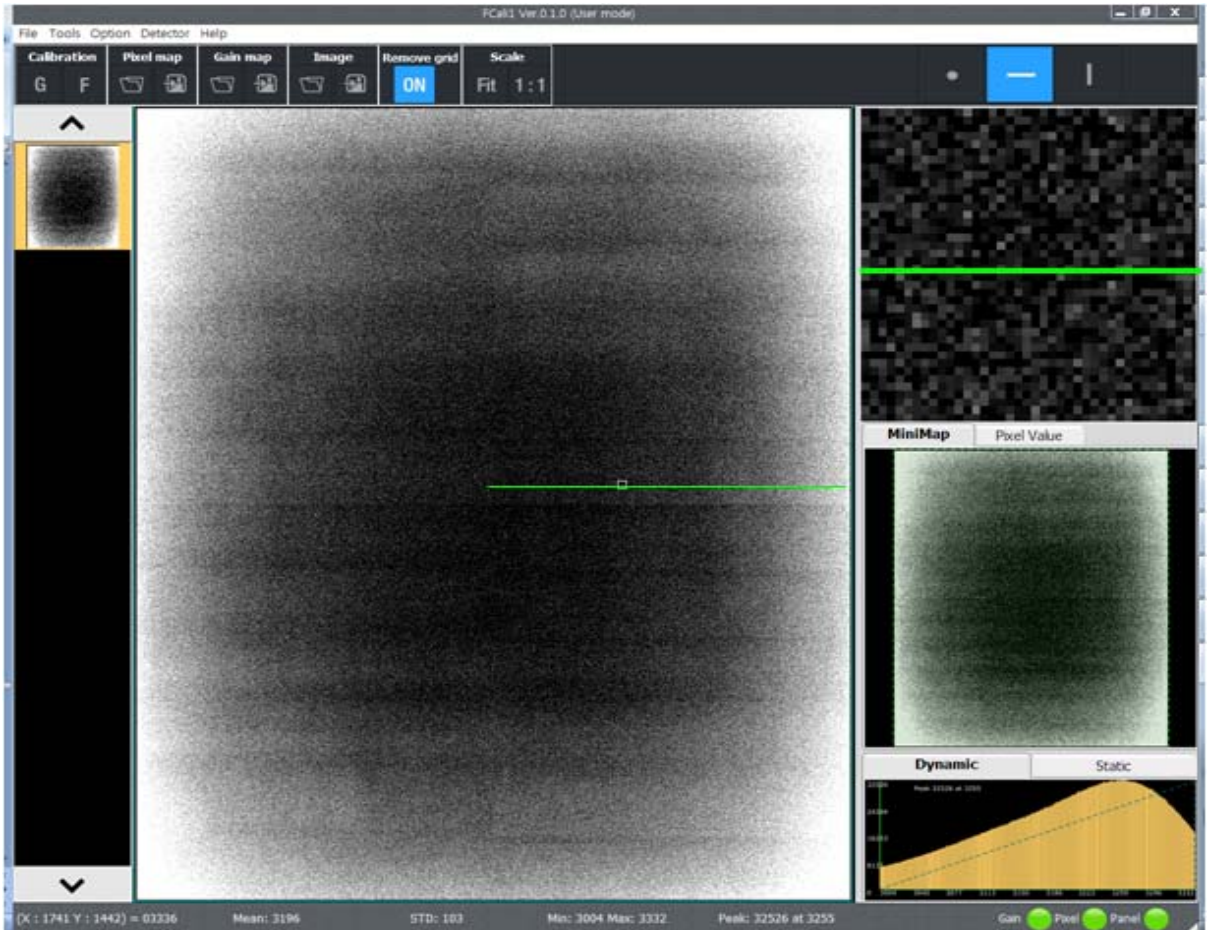

Figure 7.63. Example Post Performance of Pixel Correction

Perform Pixel Corrections for all existing Defect and save to complete the process.

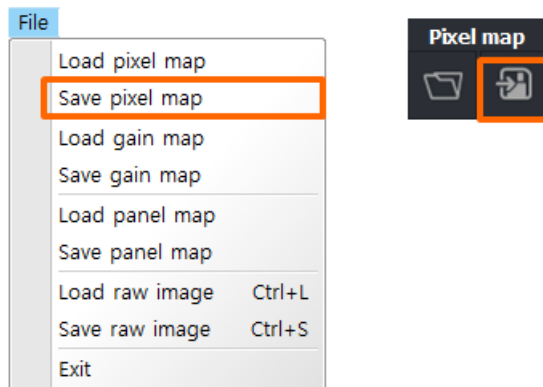

Figure 7.64. Save Pixel Map

7-12 Configuration

The Configuration will appear through Option Menu - Configuration.

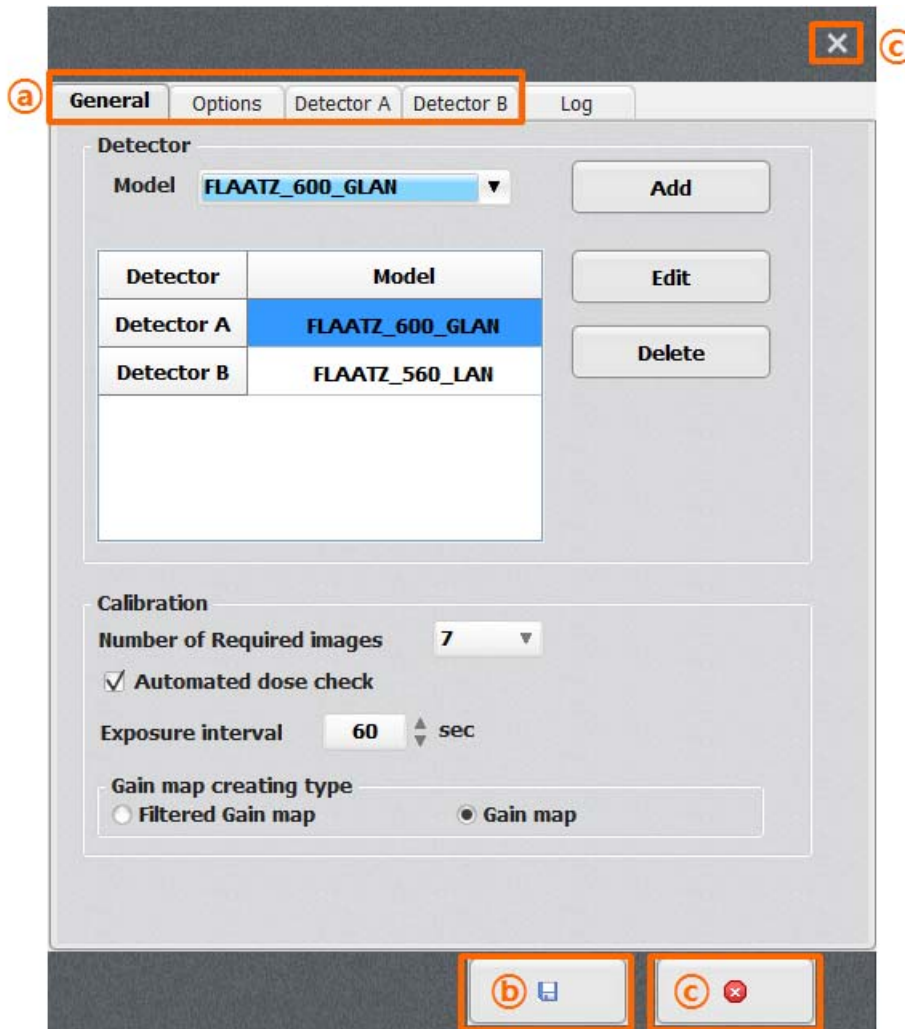

Figure 7.65. Configuration

- ✓ (a): Configuration detailed tab
- ✓ (b): Save the modified contents and close the window.
 - Automatically restart the program when necessary.
- ✓ (c): Close the window without saving the contents.

7-12-1 General

Configure the number and type of Detector being utilized.

In addition, Configuration matters required in the process of calibration may be modified.

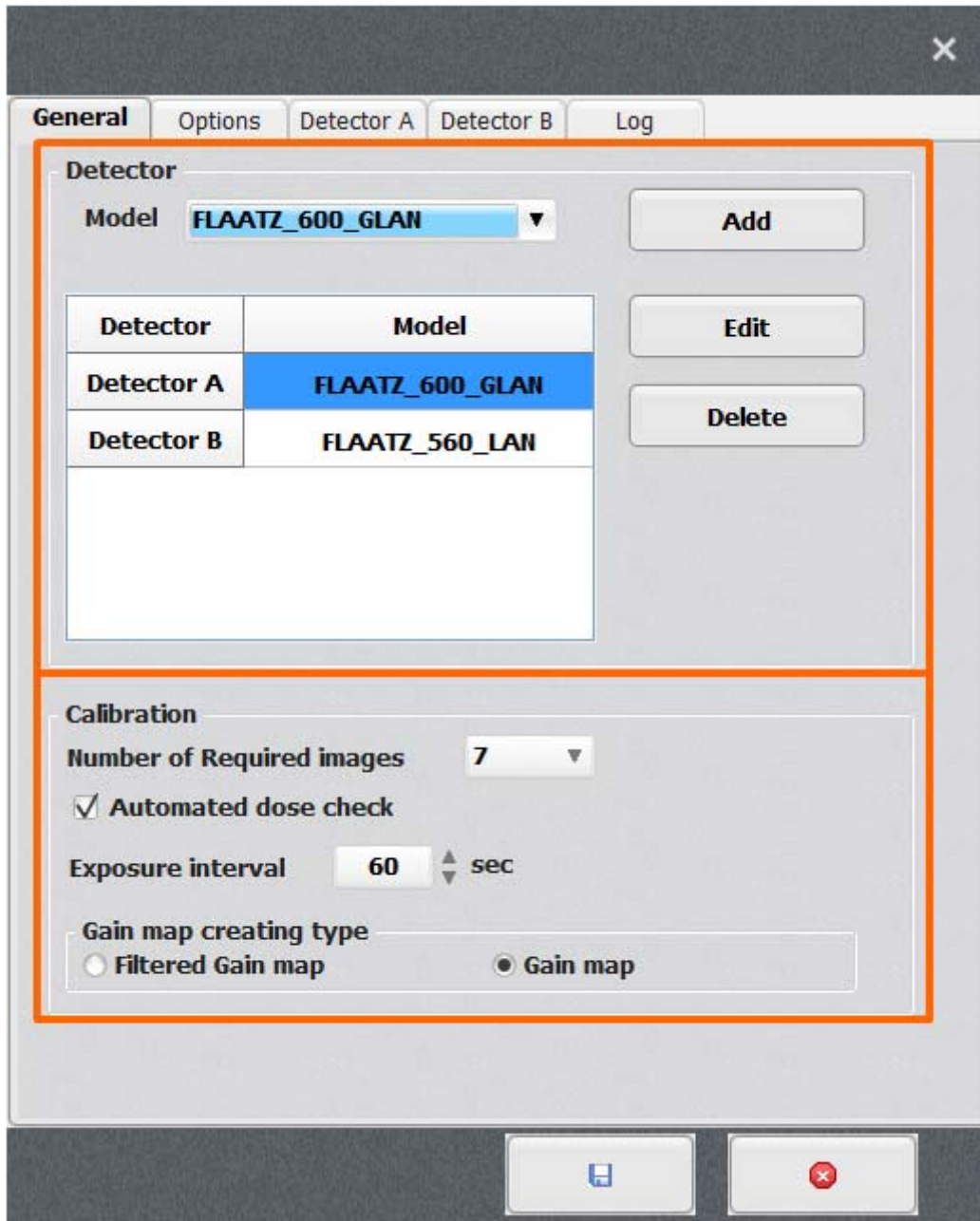

Figure 7.66. General

1) Detector Configuration

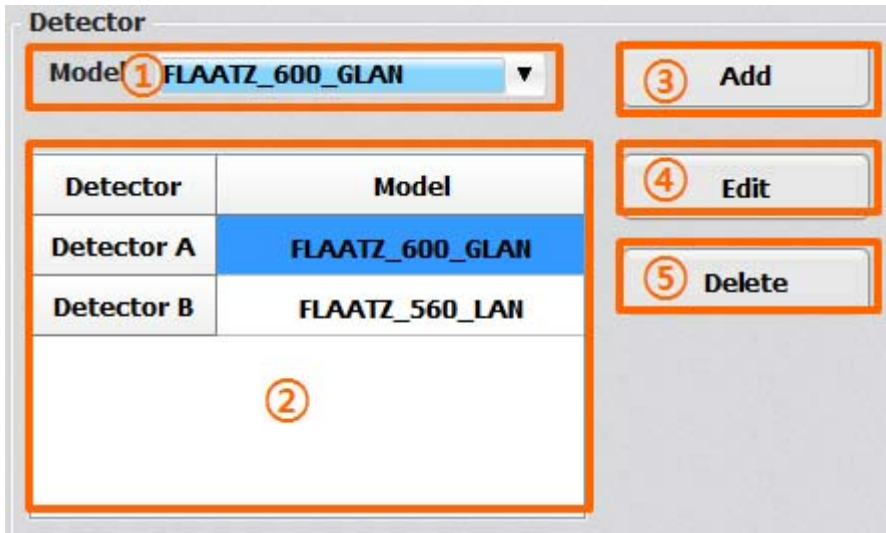

Figure 7.67. Detector Configuration

Table 7-10. Model Configuration Descriptions

Category	Descriptions
①	Type of Panel Model which will be added or modified
②	Type of Panel added (registered)
③	Adds the Panel Model selected in ①
④	Modifies the Model of the Panel selected in ② Here, the Model is replaced by the Model selected in ①
⑤	Deletes the most recently registered Panel. (With disregards to selection, the item at the bottom of the list will be deleted.)

2) Calibration Configuration

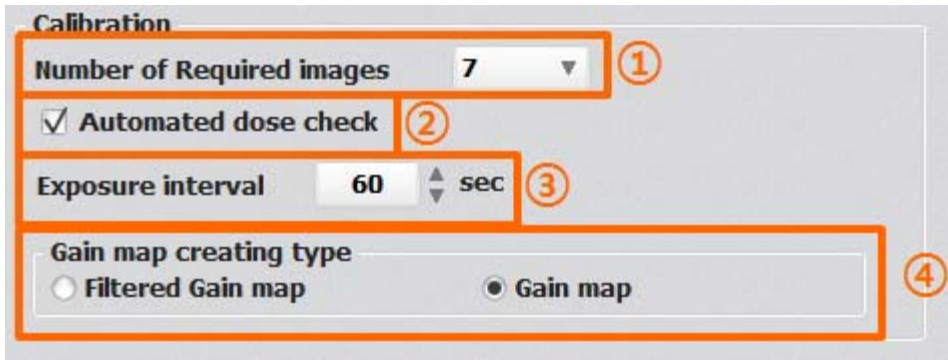

Figure7.68. Calibration Configuration

Table 7-5. Calibration Configuration Descriptions

Category	Descriptions
①	Configures the number of images to be project when performing Gain/Grid Calibration. The Default value is 7 counts.
②	Checks the X-ray radiation dose when performing Gain Calibration and provides an option for re-projection if the radiation dose is unfit. It is recommended for accurate Calibration.
③	Configures the interval between each image projections when performing Gain/Grid/Panel Calibration. The default value is 60 sec.
④	Select whether to set the Grain Map as Filtered Gain Map or Gain Map.

7-12-2 Options

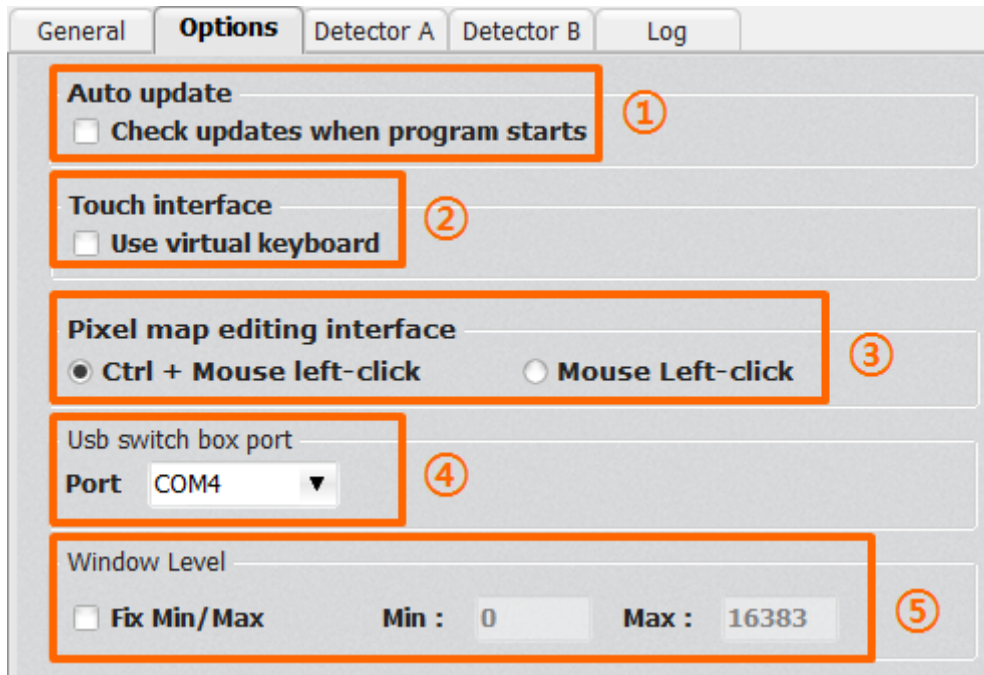

Figure 7.69. Options Configuration

Table 7-6. Options Descriptions

Category	Descriptions
①	Configures the use of Auto Update function.
②	Configures the use of the virtual keyboard for Touch environments.
③	Selects the editing method utilized during the Pixel Map Calibration process.
④	Selects the port connected with USB Switch Box.
⑤	Checks 'Fix Min / Max' and inputs Min and Max pixel value to use fixed window level.

7-13 Detector

Allows the modification of necessary configuration for each Detector. Number of tabs corresponding to the number of registered Panels through Configuration – General will be generated.

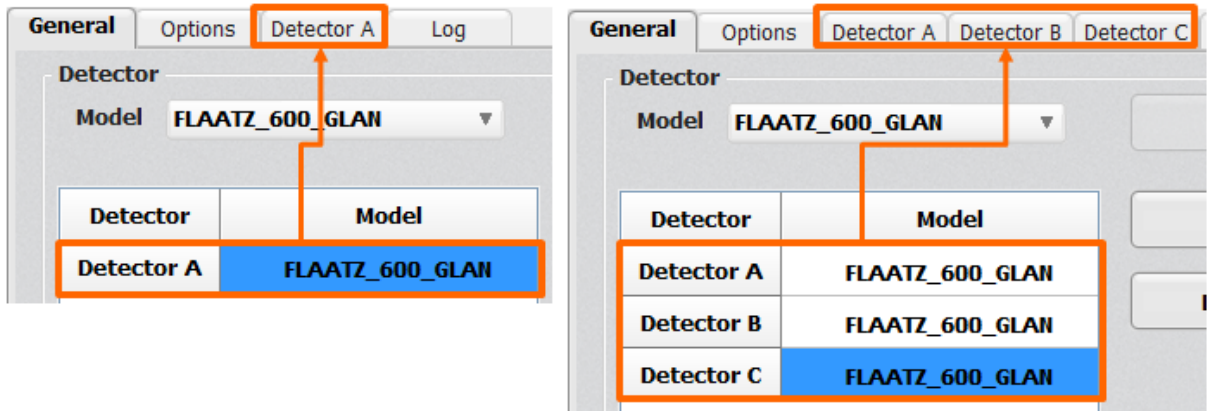

Figure 4. Configuration – Changes in the Number of Panel Tabs

The following may be configured through Panel Configurations

- ✓ Map files save path
 - Save path of the Map file required for Calibration
- ✓ Edge cut setting
 - The borders of the image
- ✓ Grid selection
 - Configurations relevant to the type of Grid and Filter Type being used
- ✓ F600 Model Configuration
 - Configurations only for F600

7-13-1 Map File Path

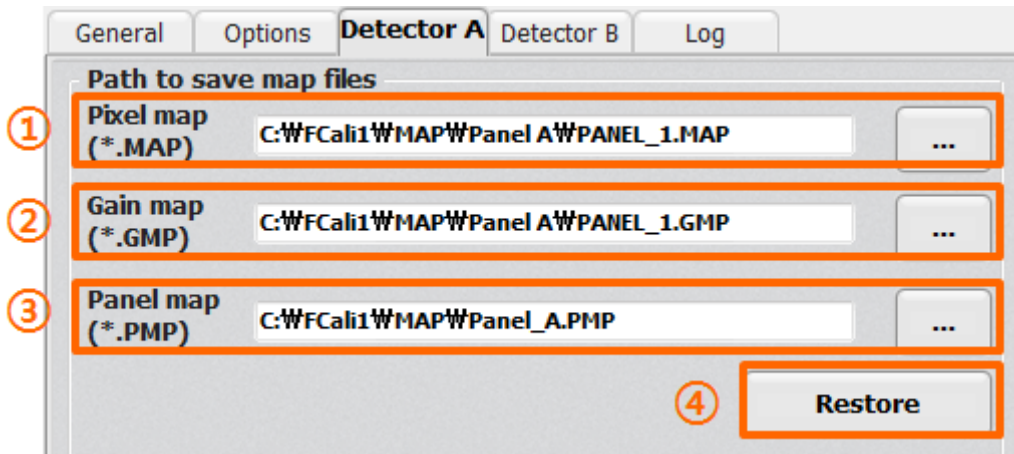

Figure 7.71. Map File Path

Table 7.7. Map File Path Descriptions

Category	Descriptions
①	Configures the save path of the Pixel Map file. The File Dialogue may be opened by selecting '...' on the right.
②	Configures the save path of the Gain Map file. The File Dialogue may be opened by selecting '...' on the right.
③	Configures the save path of the Panel Map file. The File Dialogue may be opened by selecting '...' on the right.
④	Previous Map files are backed-up when Map files are saved multiple times. Utilized when restoring the Map file with the previous file. However, restore cannot be processed if a backed-up Map file does not exist.

7-13-2 Edge Cut Setting

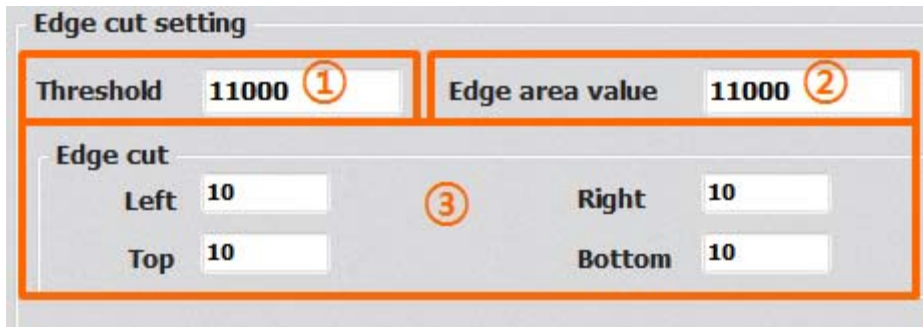

Figure 7.72. Edge Cut Setting

Fixed placement of a boarder on the image.

The Pixel value and width may be designated in this configuration.

Table 7.8. Edge Cut Setting Descriptions

Category	Descriptions
①	Configures the Threshold Value of the image. The default is determined by each model. If the Pixel Value of the image imported from the Detector exceeds 11000, the values will be automatically adjusted to 11000 if this value is set to 11000.
②	Configures the Pixel Value of the additional boarder which will be placed on the image. The default value is 11000.
③	Configures the width of the top, bottom, left and right boarder. Unit is in Pixel. The Default value is all 10.

When you encounter problems or error messages in the ECali1 while using this equipment, search the table below for the problem or error message and try the solutions.

If the problem persists, turn off the detector and consult your sales representative or local DRTECH dealer.

Please refer to the details of the problem or error messages.

Symptom	Cause/Error messages in the EVS Control Software	Remedy
Failed to turn on.	Power cable is not attached	Attach a power cable with SSU
LINK lamp does not light up	The communication circuit is not secured	Register the detector and make connection to the ECali1. In wireless configuration, confirm the following conditions: <ul style="list-style-type: none"> • There is no obstacle between the wireless module of the detector and the wireless access points. • The wireless access point is turned on. In wired configuration, confirm the following conditions: <ul style="list-style-type: none"> • The detector cable is firmly connected to the SSU(power box). • The SSU(power supply) and the AP are firmly connected via cable. • The AP is turned on and network communication is functioning properly.
While the POWER lamp lights, READY and LINK lamps flash.	Data transmission error has occurred.	In wireless configuration, confirm the following conditions: <ul style="list-style-type: none"> • The access point is turned on. • Wireless communication status is stable • The access point are firmly connected via cable. In wired configuration, confirm the following conditions: <ul style="list-style-type: none"> • The detector cable is firmly connected to the detector. • The SSU is turned on.
	Exposure preparation error has occurred. / Error Code: 21	Confirm that the cables with the X-ray interface unit are connected securely and the X-ray interface box is turned on.
All the LED lamps flash.	Hardware error has occurred /Error Code: other than 21	Turn off the detector and turn it on again.
Two LED lamps flash and Turn off the detector and turn it on again. the other flashes slowly.		

Maintenance and inspection

In order to ensure that the equipment is used safely and normally, be sure to inspect the equipment before use. If any problem is found during the inspection and cannot be corrected, please contact your sales representative or local DRTECH dealer.

Daily inspection



WARNING

For safety reasons, be sure to turn OFF the power to each piece of equipment before the following. Otherwise, an electric shock may result.

Cable

- 1) Ensure that cables are not damaged and cable jackets are not torn.
- 2) Ensure that the power cord plugs are securely connected to both the equipment AC inlet and the AC outlet.

Detector

- 1) Ensure that there are no loose screws or breaks.
- 2) Ensure that there is no dust or foreign matter on the external connector.
- 3) Ensure that there are no breaks or short-circuits in the power supply connector.

After turning on the power

Be sure to start the ECal1 before performing the following inspection.

- 1) Perform test exposure.

Monthly inspection

- 1) Conduct a Performance Test.
- 2) Regularly conduct a Self-diagnosis. For details, refer to the Setup Guide for the EVS Control Software.

Yearly inspection

- 1) Perform a Performance Test or Self-diagnosis using a phantom or resolution chart, etc.

Irregular inspection

Calibration

- 1) Perform Calibration when exposure conditions have changed significantly.
For details, refer to the Setup Guide for the ECal1.

10-1. Main specifications

EVS 3643 X-ray detector

[Dimensional diagram]

(unit mm)

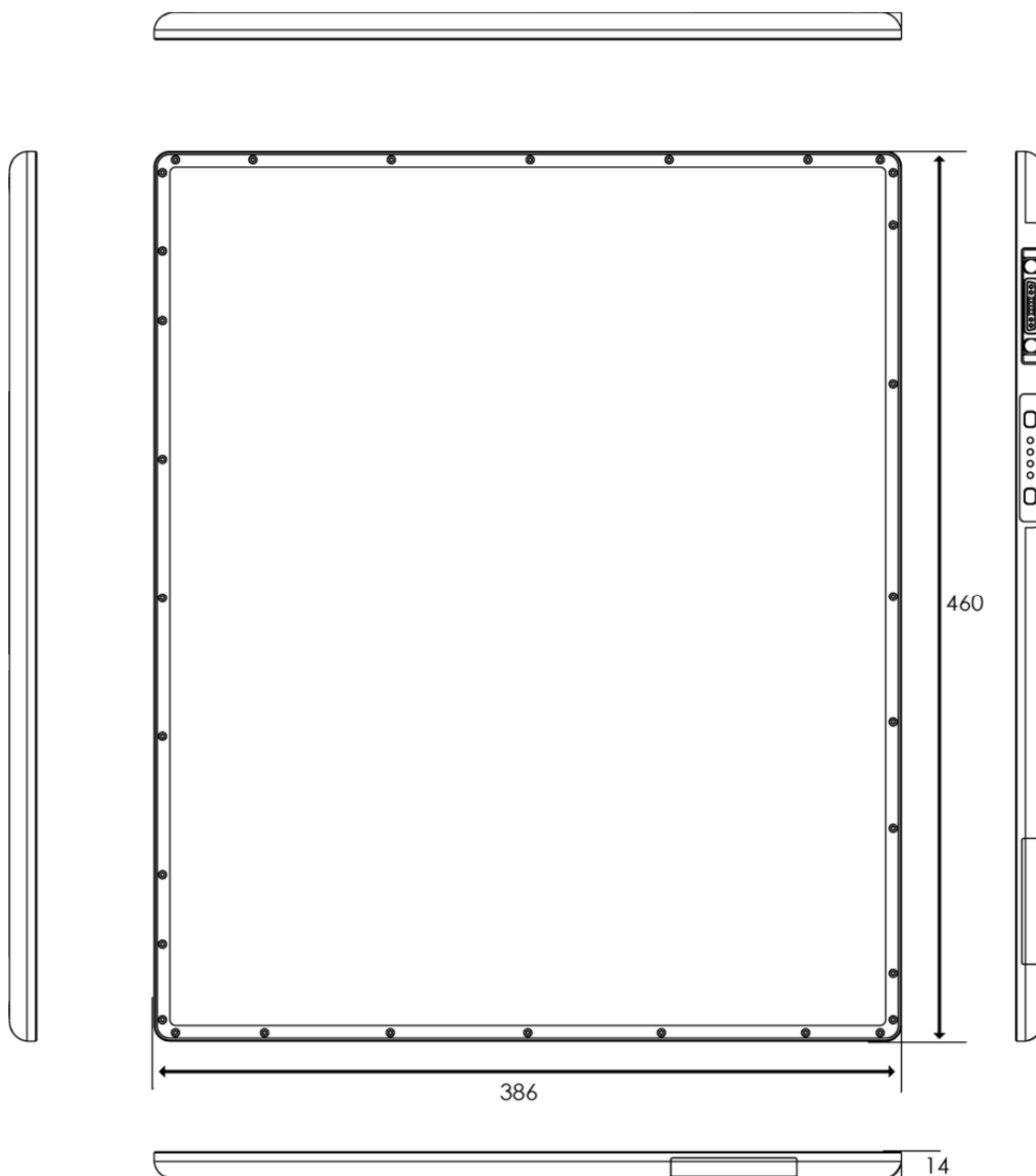

SSU (System Synchronization Unit)

[Dimensional diagram]

(unit mm)

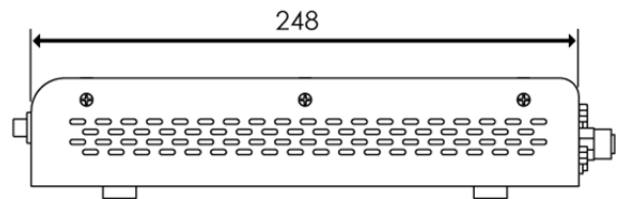
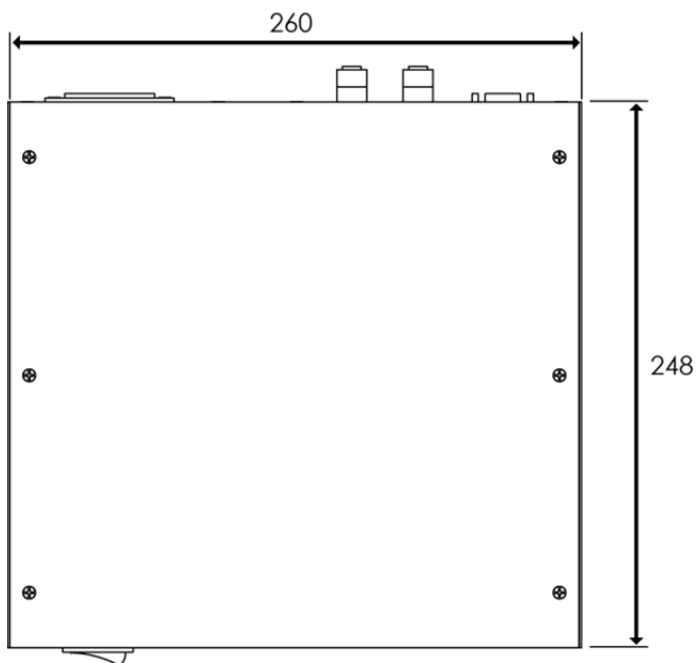

Rated power supply

Input: 100-240 VAC, 50/60Hz

Output: DC +12 V 8.3A, 75W

10-2. Characteristics

(1) Typical patient doses

Typical patient doses are equivalent to 500-1000 speed film/screen systems.

(2) Sensitometric characteristics and Dynamic range

EVS 3643 Wireless responds linearly against the exposure range for 500-1000 speed film/screen where it can depict the clinical information. It means that EVS 3643 fully covers a dynamic range of 0.2-20 μGy at least.

(3) Spatial resolution properties

A typical MTF value at 2 cycle/mm, RQA5 is 0.35.

The level of uncertainty is estimated as less than $\pm 10\%$.

(4) DQE

A typical DQE value at 2 μGy in 0 lp/mm is 0.6.

The level of uncertainty is estimated as less than $\pm 10\%$.

The product safety standards that apply to the EVS 3643, which includes the following equipment, are as followings.

- Detector
- SSU
- Wiring unit (sold separately, optional unit)

11-1. Medical equipment safety standards

□ Medical equipment classification

Type of protection against electrical shock	Class I ME Equipment
Degree of protection against electrical shock	Type B Applied Parts (Applied Part: Detector panel)
Degree of protection against ingress of water	IPX0
Mode of operation	Continuous Operation
Flammable anesthetics	Not suitable for use in the presence of a flammable anesthetic mixture with air or with oxygen or nitrous oxide

□ Product safety standards

USA and Canada

IEC 60601-1:1988 +A1:1991+A2:1995	Medical electrical equipment-Part 1:General requirements for safety
UL 60601-1 Ed.1.0:2003	
CAN/CSA C22.2 No.601.1	
IEC 60601-1-1 Ed.2.0:2000	Medical electrical equipment-Part 1-1:Collateral standard: Safety requirements for medical electrical systems
IEC 60601-1-2 Ed.2.1:2004	Medical electrical equipment-Part 1-2:Collateral standard: Electromagnetic compatibility-Requirements and tests
IEC 60601-1-3 Ed.1.0:1994	Medical electrical equipment-Part1:Collateral standard: General requirements for radiation protection in diagnostic X-ray equipment
IEC 60601-1-4 Ed.1.1:2000	Medical electrical equipment - Part 1-4:Collateral Standard: Programmable electrical medical systems
IEC 60601-2-32 Ed.1.0:1994	Medical electrical equipment - Part 2: Particular requirements for the safety of associated equipment of X-ray equipment
ISO 10993-1:2003/-5:1999/ 10993-10:2002+A1:2006	Biological evaluation of medical devices Part 1: Evaluation and testing within a risk management process Part 5: Tests for in vitro cytotoxicity Part 10: Tests for irritation and delayed-type hypersensitivity

European Union

MDD(93/42/EEC)	Medical Device Directive
EN ISO 13485:2003+AC:2007	Medical devices -- Quality management systems – Requirements for regulatory purposes
EN 60601-1:1990+ A1:1993+A2:1995+A13:1996	Medical electrical equipment - Part1:General requirements for safety
EN 60601-1-1:2001	Medical electrical equipment-Part 1-1:Collateral standard: Safety requirements for medical electrical systems
EN 60601-1-2:2001	Medical electrical equipment-Part 1-2:Collateral standard: Electromagnetic compatibility-Requirements and tests
EN 60601-1-3(29.203):1994	Medical electrical equipment-Part 1-3:Collateral standard: General requirements for radiation protection in diagnostic X-ray equipment
EN 60601-1-4:1996+A1:1999	Medical electrical equipment - Part 1-4:Collateral Standard: Programmable electrical medical systems
EN 60601-1-6:2004	Medical electrical equipment - Part 1-6:Collateral Standard: Usability
EN 60601-2-32:1994	Medical electrical equipment - Part 2: Particular requirements for the safety of associated equipment of X-ray equipment
EN 62304:2006	Medical device software-Software life cycle processes
EN 62366:2008	Medical device - Application of usability engineering to medical devices
EN ISO 14971:2007	Medical device - Application of risk management to medical devices
EN ISO 10993-1:2003/-5:1999/ 10993-10:2002+A1:2006	Biological evaluation of medical devices Part 1: Evaluation and testing within a risk management process

11-2. Medical equipment safety standards

Declaration of conformity

U.S.A.	FCC Part 15 Subpart B Class A and Part 15 Subpart C & E (RF Exposure)
Canada	RSS-210
European Union (and EEA)	ETSI EN300 328-1,-2 / 300 893-1,-2(Emission) ETSI EN301 489-1.-17 (Immunity)
Australia	AS4268
Singapore	IDA TS-14

For U.S.A. and Canada

• FCC/IC compliance

This device complies with Part 15 of the FCC Rules and RSS-Gen of IC Rules.

Operation is subject to the following two conditions:

1. This device may not cause harmful interference.

2. This device must accept any interference received, including interference that may cause undesired operation.

Note: This equipment has been tested and found to comply with the limits for a Class A digital device, pursuant to part 15 of the FCC Rules. These limits are designed to provide reasonable protection against harmful interference when the equipment is operated in a commercial environment. This equipment generates, uses, and can radiate radio frequency energy and, if not installed and used in accordance with the instruction manual, may cause harmful interference to radio communications. Operation of this equipment in a residential area is likely to cause harmful interference in which case the user will be required to correct the interference at his own expense.

FCC WARNING:

Changes or modifications not expressly approved by the party responsible for compliance could void the user's authority to operate the equipment.

This transmitter must not be co-located or operated in conjunction with any other antenna or transmitter

5150~5250 MHz band is restricted to indoor operations only. (for FCC and CE)

FCC ID: RNH-EVS3643

FCC ID: RNH-EVS3643 in the RF module do not use DFS band. *RF module FCC ID: RYK-WUBR508N.

Host device of the approved module shall be marked with the following item:

Contains Transmitter Module FCC ID: RYK-WUBR508N

Disposal

Disposal of this product in an unlawful manner may have negative effects on health and on the environment. When disposing of this product, therefore, be absolutely sure to follow the procedure which is in conformity with the laws and regulations applicable in your area.

 The expected life span of EVS 3643 system is about 3 years.

□ For European Union (and EEA)

English	Hereby, DRTECH Inc., declares that this EVS-3643 Wireless is in compliance with the essential requirements and other relevant provisions of Directive 1999/5/EC.
Česky	DRTECH Inc. tímto prohlašuje, že tento EVS 3643 Wireless je ve shodě se základními požadavky a dalšími příslušnými ustanoveními směrnice 1999/5/ES.
Dansk	Undertegnede DRTECH Inc. erklærer herved, at følgende udstyr EVS 3643 Wireless overholder de væsentlige krav og øvrige relevante krav i direktiv 1999/5/EF.
Deutsch	Hiermit erkläre DRTECH Inc., dass sich das Gerät EVS 3643 Wireless in Übereinstimmung mit den grundlegenden Anforderungen und den übrigen einschlägigen Bestimmungen der Richtlinie 1999/5/EG befindet.
Eesti	Käesolevaga kinnitab DRTECH Inc. seadme EVS 3643 Wireless vastavust direktiivi 1999/5/EÜ põhinõuetele ja nimetatud direktiivist tulenevatele teistele asjakohastele sätetele.
Español	Por medio de la presente DRTECH Inc. declara que el EVS 3643 Wireless cumple con los requisitos esenciales y cualesquiera otras disposiciones aplicables o exigibles de la Directiva 1999/5/CE.
Ελληνική	ΜΕ ΤΗΝ ΠΑΡΟΥΣΑ DRTECH Inc. ΔΗΛΩΝΕΙ ΤΙ ΕVS 3643 Wireless ΣΥΜΜΟΡΦΩΝΕΤΑΙ ΠΡΟΣ ΤΙΣ ΥΣΙΩΔΕΙΣ ΑΠΑΙΤΗΣΕΙΣ ΚΑΙ ΤΙΣ ΛΙΠΕΣ ΣΕΤΙΚΕΣ ΔΙΑΤΑΞΕΙΣ ΤΗΣ ΔΗΓΙΑΣ 1999/5/ΕΚ.
Français	Par la présente DRTECH Inc. déclare que l'appareil EVS 3643 Wireless est conforme aux exigences essentielles et aux autres dispositions pertinentes de la directive 1999/5/CE.
Italiano	Con la presente DRTECH Inc. dichiara che questo EVS 3643 Wireless è conforme ai requisiti essenziali ed alle altre disposizioni pertinenti stabilite dalla direttiva 1999/5/CE.
Latviski	Ar šo DRTECH Inc. deklare, ka EVS 3643 Wireless atbilst Direktivas 1999/5/EK butiskajam prasibam un citiem ar to saistitajiem noteikumiem.
Lietuviu	Šiuo DRTECH Inc. deklaruoja, kad šis EVS 3643 Wireless atitinka esminius reikalavimus ir kitas 1999/5/EB Direktyvos nuostatas.
Nederlands	Hierbij verklaart DRTECH Inc. dat het toestel EVS 3643 Wireless in overeenstemming is met de essentiële eisen en de andere relevante bepalingen van richtlijn 1999/5/EG.
Malti	Hawnhekk, DRTECH Inc., jiddikjara li dan EVS 3643 Wireless jikkonforma malhtigijiet essenzjali u ma provvedimenti ohrajn relevanti li hemm fid-Dirrettiva 1999/5/EC.
Magyar	Alulírott, DRTECH Inc. nyilatkozom, hogy a EVS 3643 Wireless megfelel a vonatkozó alapvető követelményeknek és az 1999/5/EC irányelv egyéb előírásainak.
Polski	Niniejszym DRTECH Inc. oświadcza, że EVS 3643 Wireless jest zgodny z zasadniczymi wymogami oraz pozostałymi stosownymi postanowieniami Dyrektywy 1999/5/EC.
Português	DRTECH Inc. declara que este EVS 3643 Wireless está conforme com os requisitos essenciais e outras disposições da Directiva 1999/5/CE.
Slovensko	DRTECH Inc. izjavlja, da je ta EVS 3643 Wireless v skladu z bistvenimi zahtevami in ostalimi relevantnimi določili direktive 1999/5/ES.
Slovensky	DRTECH Inc. týmto vyhlasuje, že [typ zariadenia] spĺna základné požiadavky a všetky príslušné ustanovenia Smernice 1999/5/ES.
Suomi	DRTECH Inc. vakuuttaa täten että EVS 3643 Wireless tyyppinen laite on direktiivin 1999/5/EY oleellisten vaatimusten ja sitä koskevien direktiivin muiden ehtojen mukainen.
Svenska	Härmed intygar DRTECH Inc. att denna EVS 3643 Wireless står i överensstämmelse med de väsentliga egenskapskrav och övriga relevant bestämmelser som framgår av direktiv 1999/5/EG.
Íslenska	Hér með lýsir DRTECH Inc. yfir því að EVS 3643 Wireless er í samræmi við grunnkröfur og aðrar kröfur, sem gerðar eru í tilskipun 1999/5/EC.
Norsk	DRTECH Inc. erklærer herved at utstyret EVS-3643 Wireless er i samsvar med de grunnleggende krav og øvrige relevante krav i direktiv 1999/5/EF.

AT	BE	BG	CY	CZ	DK	EE	FI
FR*	DE	GR	HU	IE	IT	LV	LT
LU	MT	NL	PL	PT	RO	SK	SI
ES	SE	GB	IS	LI	NO	CH	

* In France, outdoor use of this equipment is prohibited.

For Singapore

Complies with IDA Standards N1624-10

11-3. Medical equipment safety standards

The EVS 3643 detector and other components have labels and markings on them.

Their contents and locations are indicated below.

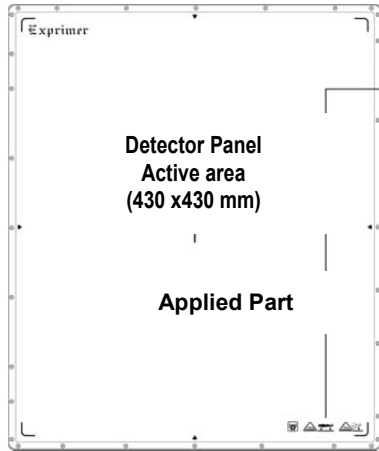

	This Mark indicates that this is Type B Applied Part according to UL 60601-1 and EN 60601-1 Applied Part
	This Mark indicates that this equipment must be handled with care
	Do not jolt or excessive load to the equipment
	Do not jolt or excessive load to the equipment

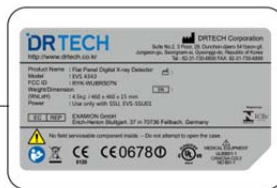
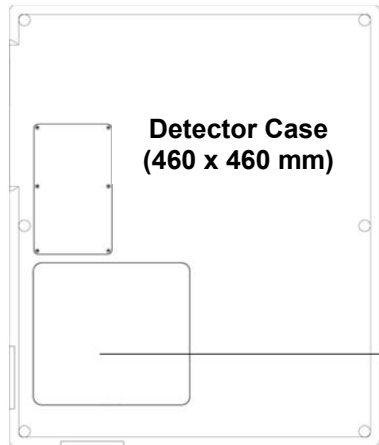

Caution:
Do not jolt or apply excessive load.



Non-ionized radiation



The Waste Electrical and Electronic Equipment Regulations indicates separate collection for electrical and electronic equipment.



MEDICAL EQUIPMENT/UL60601-1 CAN/CSA C22.2 No.601.1 41C4

Certification mark that indicates the product complies with UL 60601-1 and CAN/CSA C22.2 No.601.1, that specifies protection against fire, electric shock, and mechanical hazards.

For U.S.A

Rx Only

Caution:

Federal law restricts this device to sale by or on the order of a licensed practitioner.

For European Union (EEC Countries)

CE 0120

Hereby, DRTECH Inc., declares that this EVS-3643 Wireless is in compliance with the essential requirements and other relevant provisions of Directive 1999/5/EC and 93/42/EEC. "0120" shows the notified body number for MDD.

MANUFACTURED: (S/N)

Year and Month of production
Serial number in six digits

CE 1177

This mark shows compliance of the equipment with Directive 93/42/EEC



Protective Earth (Ground)



Direct Current



Alternating Current



Equipotentially.



Attention, Consult accompanying documents.



Power Off.



Power On



Read and understand all instructions and warning labels in the product documentation before using the equipment.
Keep manual for future reference



Protective Earth (Ground)



Direct Current



Alternating Current



Equipotentially.



Attention, Consult accompanying documents.



Power Off.



Power On



Read and understand all instructions and warning labels in the product documentation before using the equipment.
Keep manual for future reference

11-4. Guidance and manufacturer's declaration for EMC

Electromagnetic emissions

The EVS 3643 Wireless is intended for use in the electromagnetic environment specified below.

The user of the EVS 3643 Wireless should assure that it is used in such an environment.

Emission Test	Compliance	Electromagnetic Environment - Guidance
RF emissions CISPR11	GROUP 1	The EVS 3643 Wireless uses RF energy only for its internal function. Therefore, its RF emissions are very low and are not likely to cause any interference in nearby electromagnetic equipment.
RF emissions CISPR11	Class A	The EVS-3643 Wireless is suitable for use in all establishments other than domestic and those directly connected to the public low-voltage power supply network that supplies buildings used for domestic purposes.
Harmonic emissions IEC 61000-3-2	Class A	
Voltage fluctuations/ flicker emissions IEC 61000-3-3	*1	

1: Applies to regions where the rated voltage is 220 V or higher. Not applicable to regions where the rated voltage is less than 220 V.

Electromagnetic immunity

The EVS 3643 Wireless is intended for use in the electromagnetic environment specified below.

The user of the EVS 3643 Wireless should assure that it is used in such an environment.

Immunity Test	IEC 60601 Test Level	Compliance Level	Electromagnetic Environment – Guidance
Electrostatic discharge (ESD) IEC 61000-4-2	±(2, 4, 6) kV contact ±(2, 4, 8) kV air	±(2, 4, 6) kV contact ±(2, 4, 8) kV air	Floors should be wood, concrete or ceramic tile. If floors are covered with synthetic material, the relative humidity should be at least 30%.
Electrical fast transient/burst IEC 61000-4-4	±2 kV for power supply lines ±1 kV for input/output lines	±2 kV for power supply lines ±1 kV for input/output lines	Mains power quality should be that of a typical commercial or hospital environment.
Surge IEC 61000-4-5	±1 kV differential mode ±2 kV common mode	±1 kV differential mode ±2 kV common mode	Mains power quality should be that of a typical commercial or hospital environment

NOTE: UT is the a.c. mains voltage prior to application of the test level.

Immunity Test	IEC 60601 Test Level	Compliance Level	Electromagnetic Environment – Guidance
Voltage dips, short interruptions and voltage variations on power supply input lines IEC 61000-4-11	<5% UT (>95% dip in UT) for 0.5 cycle. 40% UT (60% dip in UT) for 5 cycles 70% UT (30% dip in UT) for 25 cycles <5% UT (>95% dip in UT) for 5 sec.	<5% UT (>95% dip in UT) for 0.5 cycle. 40% UT (60% dip in UT) for 5 cycles 70% UT (30% dip in UT) for 25 cycles <5% UT (>95% dip in UT) for 5 sec.	Mains power quality should be that of a typical commercial or hospital environment. If the user of the EVS 3643 Wireless requires continued operation during power mains interruptions, it is recommended that the EVS 3643 Wireless be powered from an uninterruptible power supply
Power frequency (50/60Hz) magnetic field IEC 61000-4-8	3 A/m	3 A/m	Power frequency magnetic fields should be at levels characteristic of a typical location in a typical commercial or hospital environment.
Conducted RF IEC 61000-4-6 Radiated RF IEC 61000-4-3	3 Vrms 150 kHz to 80 MHz 3 V/m 80 MHz to 2.5 GHz	3 Vrms 3 V/m	The RF communications equipment should be used no closer to any part of the EVS 3643 Wireless, including cables, than the recommended separation distance calculated from the equation applicable to the frequency of the transmitter. Recommended separations distance $d=1.2 \sqrt{P}$ $d=1.2 \sqrt{P}$ 80 MHz to 800 MHz $d=2.3 \sqrt{P}$ 800 MHz to 2.5 GHz where P is the maximum output power rating of the transmitter in watts (W) according to the transmitter manufacturer and d is the recommended separation distance in meters (m). Field strengths from fixed RF transmitters, as determined by an electromagnetic site survey a, should be less than the compliance level in each frequency range b. Interference may occur in the vicinity of equipment marked with the following symbol: 
NOTE 1: At 80 MHz and 800 MHz, the higher frequency range applies. NOTE 2: These guidelines may not apply in all situations. Electromagnetic propagation is affected by absorption and reflections from structures, object and people.			

- a Field strengths from fixed transmitters, such as base stations for radio (cellular/cordless) telephones and land mobile radios, amateur radio, AM and FM radio broadcast and TV broadcast cannot be predicted theoretically with accuracy. To assess the electromagnetic environment due to fixed RF transmitters, an electromagnetic site survey should be considered. If the measured field strength in the location in which the EVS 3643 Wireless is used exceeds the applicable RF compliance level above, the EVS 3643 Wireless should be observed to verify normal operation. If abnormal performance is observed, additional measures may be necessary, such as reorienting or relocating the EVS 3643 Wireless.
- b Over the frequency range 150 kHz to 80 MHz, field strengths should be less than 3 V/m.

DRTECH Inc. warrants that this product will be free from defects in materials and workmanship for a period of twelve (12) months from the date of delivery. If any such product proves defective during this warranty period, DRTECH Inc. at its option, either will repair the defective product without charge for parts and labor, or will provide a replacement in exchange for the defective product. In order to obtain service under this warranty, Customer must notify DRTECH Inc. of the defect before the expiration of the warranty period and make suitable arrangements for the performance of service. Customer shall be responsible for packaging and shipping the defective product to the service center designated by DRTECH Inc. with shipping charges prepaid. DRTECH Inc. shall pay for the return of the product to customer if the shipment is to a location within the country in which the DRTECH Inc. designated service center is located. Customer shall be responsible for paying all shipping charges, duties, taxes, and any other charges for products returned to any other locations.

This warranty shall not apply to any defect, failure, or damage caused by improper or inadequate maintenance and care. DRTECH Inc. shall not be obligated to furnish service under this warranty to repair damage resulting from attempts by personnel other than DRTECH Inc. or its representatives to install, repair, or service this product, to repair damage resulting from improper use or connection to incompatible equipment or power source; or to service a product that has been modified or integrated with other products when the effect of such modification or integration increases the time or difficulty of servicing the product.

THIS WARRANTY IS GIVEN BY DRTECH Inc. WITH RESPECT TO THIS PRODUCT IN LIEU OF ANY OTHER WARRANTIES, EXPRESS OR IMPLIED. DRTECH Inc. AND ITS VENDOR DISCLAIM ANY IMPLIED WARRANTIES OF MERCHANTABILITY OR FITNESS FOR A PARTICULAR PURPOSE. DRTECH Inc. RESPONSIBILITY TO REPAIR OR REPLACE DEFECTIVE PRODUCTS IS THE SOLE REMEDY PROVIDED TO THE CUSTOMER FOR BREACH OF THIS WARRANTY. DRTECH AND ITS VENDORS WILL NOT BE LIABLE FOR ANY INDIRECT, SPECIAL, INCIDENTAL, OR CONSEQUENTIAL DAMAGES IRRESPECTIVE OF WHETHER VIEWWORKS CO., LTD OR THE VENDOR HAS ADVANCE NOTICE OF THE POSSIBILITY OF SUCH DAMAGES.

There are no warranties which extend beyond the description mentioned in this document.

Revision History

Revision	Date	Descriptions
1.0	Feb. 11. 2014	Initial Release

DRTECH



DRTECH Inc.

Suite No.2 3 Floor, 29

Dunchon-daero541beon -gil,

Jungwon-gu, Seongnam-si, Gyeonggi-do, Republic of Korea

Web Site : <http://www.drtech.co.kr>

Customer Support Team

E-mail : drtech@drtech.co.kr

Tel : +82 31 730 6805 / Fax : +82 31 730 6899



European representative: