

Switch Selectable 5W - 2W Video Transmitter

VMS-5000 Frequency 2450-2500 MHz



DTC COMMUNICATIONS INCORPORATED

How to contact DTC

For operator and troubleshooting information, customers are encouraged to refer to the details in this manual. For additional clarification or instruction, or to order parts, contact DTC.

Customer Service is available Monday through Friday between the hours of 9:00 AM and 5:00 PM EST at:

Tel: 603-880-4411

Fax: 603-880-6965

Website: www.dtccom.com

Email: info@dtccom.com

486 Amherst Street
Nashua, New Hampshire 03063
USA

Copyright Notice

Copyright © 2003

DTC Communications, Inc. All rights reserved. No part of this document may be reproduced, transmitted, transcribed, stored in a retrieval system or translated into any language or computer language, in any form or by any means, including but not limited to electronic, magnetic, mechanical, optical, chemical, manual or otherwise, without the prior written permission of DTC Communications, Inc.

Disclaimer

The information in the document is subject to change without notice. DTC makes no representations or warranties with respect to the contents hereof, and specifically disclaims any implied warranties of merchantability or fitness for a particular purpose. DTC reserves the right to revise this publication and to make changes from time to time in the content hereof without obligation of DTC to notify any person of such revision or changes.

Trademarks

Trademarks of DTC Communications, Inc. include:

- DTC
- MiniPIX®
- DynaPIX®

Other product names used in this manual are the properties of their respective owners.

Warranty

DTC warrants its manufactured components against defects in material and workmanship for a period of two (2) years, commencing on the date of original purchase.

Products manufactured by others that are approved for use with DTC equipment are warranted for the manufacturer's warranty period, commencing from the date of shipment from DTC.

FCC information

Forms can be obtained from the FCC on their website at:

www.fcc.gov

You can also contact the FCC using their FAX back service at: (888) 418-3676

Additional instructions are available by telephone at: (888) 225-5322

The filing fee form is returned to:

Federal Communications Commission
1270 Fairfield Road
Gettysburg, PA 17325-7245

Manual Conventions

 **NOTE** Describes special issues you should be aware of while using a particular function.

 **WARNING** Calls out situations in which equipment could be damaged or a process could be incorrectly implemented, but in which operator safety is not a factor.

 **TIP** Describes application hints.

RF EXPOSURE STATEMENT

This product is NOT recommended for use in body-worn applications. Refer to Appendix A in this manual for instruction in the proper use of antennas with this device. When in use a separation distance of at least 20 cm must be maintained between the supplied antenna and the body of the user or nearby persons. At this distance the field density will be 1.61 mW/cm², well below the maximum permissible exposure level of 5. mW/cm².

 **Note:** This device is for occupational use only. Occupational users are those persons who are exposed as a consequence of their employment, provided these persons are fully aware of and exercise control over their exposure. See Appendix A. Antenna Safety.

FCC ID# H25VMS5000

Kit Contents	4
Quick Start	5
Encryption	6
Heat Considerations	7
Mounting Options	8
Reinstalling Heatsink	9
Connectors	10
Connections	11
Basic Video Transmitter	12
Single Power Source	13
Components	14-16
Programming	17-20
Specifications	21-23
Features	24
Warranty	25
Appendix A. Antenna Safety	26

TYPICAL KIT

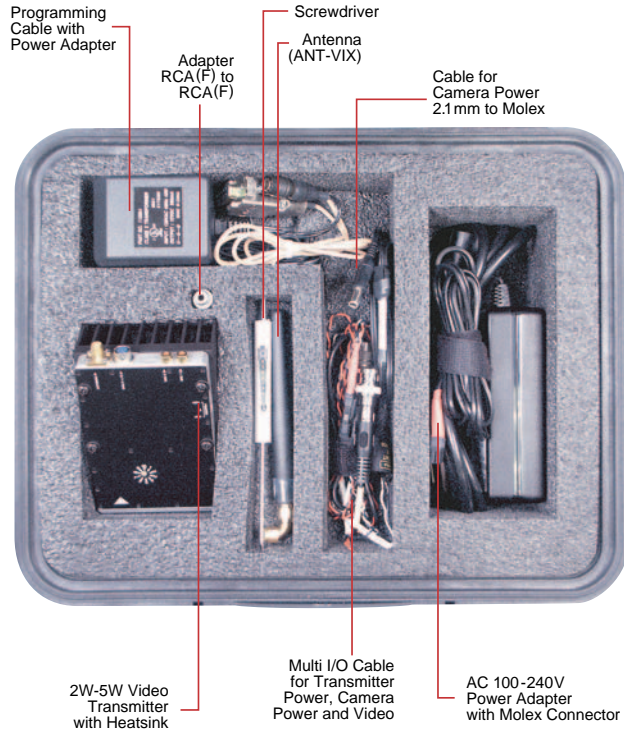

Included with your 5 Watt -2 Watt Transmitter:

- VMS-5000 Video Transmitter packaged in case with heatsink attached
- Accessories kit containing:
 - DTC programming software package
 - DTC programming cable
 - Camera Cable
 - Dipole antenna with right angle SMA connector
 - Video and Power In “Y” cable
 - Four captive mounting screws
 - Transmitter mounting bracket (optional)

✓ **NOTE:** DTC has provided you with a “Y” cable (power and video) terminated with an RCA connector and a BNC adapter for your convenience.

✓ **NOTE:** The dipole antenna included is not recommended for normal use! This antenna enables you to quickly set up your transmitter and ensure proper operation. DTC highly recommends the use of circularly polarized antennas for the best rejection of multi-path.

QUICK START

- 1 Make sure that the external power source to the transmitter is OFF.
- 2 Using a screwdriver, turn the channel selector to the correct channel number.
- 3 Connect an antenna to the ANTENNA connector on the module.
- 4 Select Hi or Lo Power using the recessed switch.
- 5 Connect the microphone or microphones to the MIC-1 and MIC-2 connectors on the module.
- 6 Connect a video source and external power (11 -16 VDC) to the Video/Multi-I/O connector.
- 7 If you are using an (optional) Encryption model, choose Encrypted (SCR) or Clear (CLR) as desired
- 8 Apply power to the transmitter.



Warning: Do not apply power to the transmitter until an antenna has been connected in step 3.

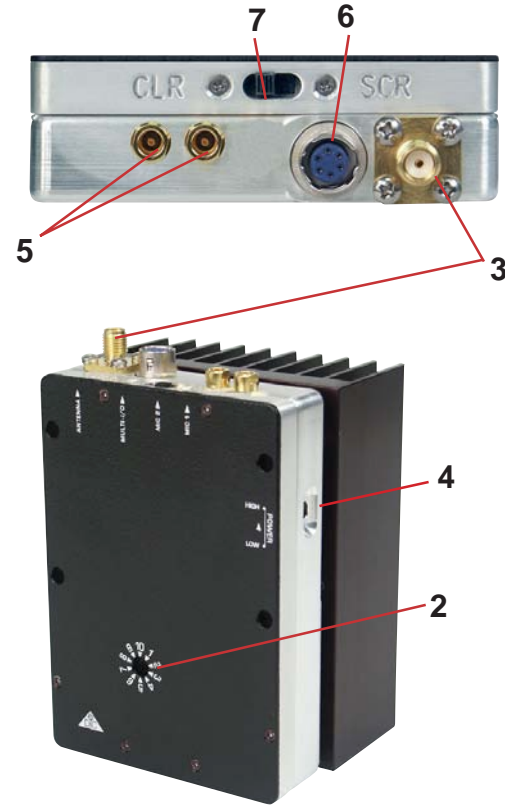

ENCRYPTION OPTION

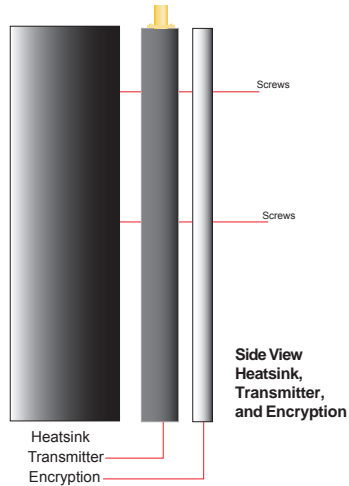
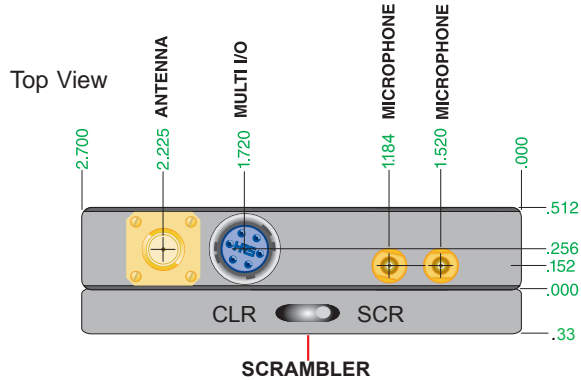

As an option, the transmitter can be equipped with an encryption module with a two position switch. In the CLR (clear) mode, clear analog microwave video is transmitted. In the SCR (scrambled) mode, the video will be scrambled and capable of being decoded by a compatible receiver only.

- ✓ Note: The scrambled transmission mode is recommended. Casual scanners will not be able to decode the signal and see what is being transmitted.
- ✓ SCR position = ON, CLR position is OFF

HEAT CONSIDERATIONS



NOTE: NEVER remove the heatsink.



NOTE: HOT SURFACE MAY CAUSE BURNS. Ensure that transmitter is properly ventilated and allow to cool before touching.

Heat is an enemy of electronic components so it is imperative that the transmitter is not allowed to exceed 80 degrees C. With the heatsink removed, the temperature would rise to 125 degrees C or more, which would be destructive to the internal components. At 125 degrees C, the unit would also deliver a serious burn if touched.

Much of the heat is given off by the final output transistor, which is the most critical component when it comes to heat considerations. The heatsink is shipped mounted to the transmitter with four 6-32 screws, and has two additional 4-40 screws attached from the fin side of the heatsink to the transmitter around the final output transistor. These screws are critical for thermal conduction from the transmitter to the heatsink. Removing these screws is not recommended.

If you plan to mount the transmitter, be sure to orient the heatsink fins vertically for effective heat dissipation. Use one of the recommended mounting procedures presented on the next page.

BEST: Fins Vertical
Away From Wall

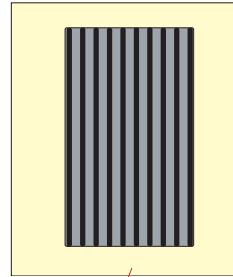

Fins Vertical
Away From Wall

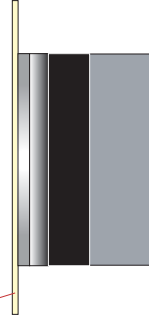

Fins Vertical
Against Wall

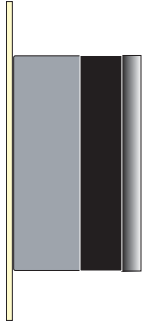

Wall

GOOD: Fins Up

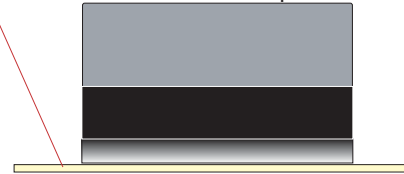

NEVER: Fins Horizontal

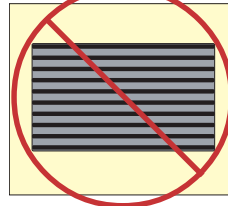

Fins Down

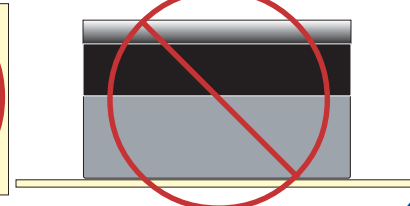

MOUNTING OPTIONS



NOTE: ALWAYS mount the transmitter with the heatsink fins oriented vertically for proper heat dissipation.



NOTE: Leave room for the antenna and/or connectors when selecting a mounting surface. The supplied antenna requires more than 5-inches of space.

Option One

The transmitter and heat sink can be mounted (with cooling fins vertical) against a heat-conductive metal surface. The transmitter ships with four additional 6-32 pan head Phillips mounting screws.

- Remove the four 6-32 Phillips screws from the front of the transmitter.
- Install the four long 6-32 Phillips screws supplied. The screws become captive.
- Pass the screws through the mounting surface and install nuts to secure the assembly.

Option Two

An optional wall-mount bracket is available from DTC Communications, which will allow simple mounting on a variety of surfaces and enclosures.

- Loosen the four 6-32 Phillips screws from the front of the transmitter.
- Install the bracket in the orientation shown. Retighten the four Phillips screws. Hang bracket on wall using #10 screws.

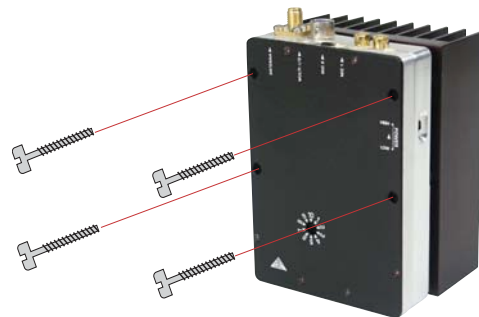

Option 1 Mounting Scheme

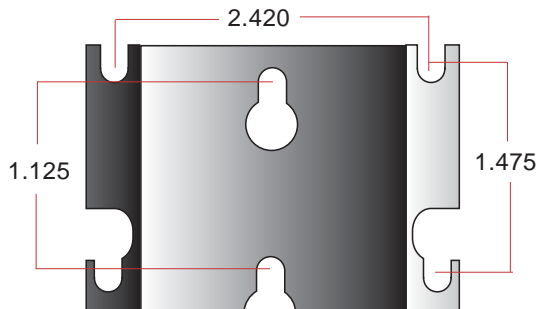

Option 2 Mounting Scheme



NOTE: The transmitter's baseplate operating temperature is -30° to $+80^{\circ}\text{C}$. The heatsink is always required. Removing the heatsink is not recommended as excessive heat can destroy the device

The transmitter is shipped with the heatsink attached. Removing the heatsink is not recommended. If, due to your particular situation, you find that you need to reinstall the heatsink, refer to the steps provided here.

To re-install the heatsink:

- 1 Ensure the chassis and heatsink surfaces are clean. If needed, use rubbing alcohol to clean, then dry.
- 2 Align the transmitter and heatsink, with the back of the transmitter mating with the front, flat surface of the heatsink.
- 3 Secure the heatsink with four (4) 6-32 x 1" screws (1-1/2" screws if using encryption model). Install the screws from the transmitter side.
- 4 Make sure there is good contact between the transmitter and the heat sink. They should be mounted flush to one another.
- 5 **IMPORTANT** Two 4-40 screws must be installed on the outside (fin side) of the heatsink to tighten the heat-conductive surfaces nearest the final output power transistor. These screws are essential for proper heat dissipation. Do not operate the transmitter with these screws removed. Screw must not exceed 0.125 depth into transmitter or it will bottom-out and not provide proper heat-conduction.



NOTE: Make sure to install all factory-provided hardware to secure heatsink to transmitter for optimal thermal conduction and heat dissipation. The temperature must never exceed 80 Deg. C.

REINSTALLING HEATSINK

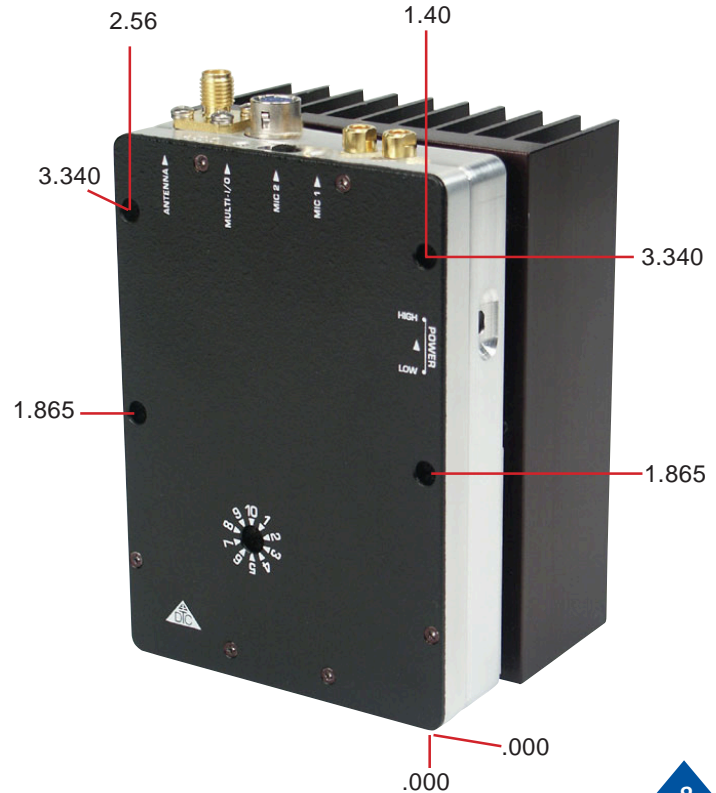

CONNECTORS



MATING CONNECTORS

Lemo Male Part # (FFS.01.250.DLAE31)
DTC Male Part # (8570003)

Hirose Part # HR10A-7P-6P (02)
DTC Part # 954020

Standard Male SMA Connector



Antenna Connector

Microphone Connectors

MICROPHONE CONNECTORS

Two connectors accommodate two microphone inputs. Each connector has two contacts and provides power to the microphone as well as connecting the audio signal into the transmitter. The audio sub-carriers are activated by the presence of the microphone. If a microphone is removed, that sub-carrier is removed from the transmit signal. Turning off the unused sub-carrier saves power and improves picture quality.

ANTENNAS

A standard SMA connector is used as the antenna connector on both the VMS-5000. Refer to a list of DTC antennas available on page 16.



WARNING: Refer to Appendix A of this manual for information on the proper use of antennas.



TIP: You may use the VMS series transmitters with other manufacturers antennas. Verify that they are suited for the band you are operating in.

CHANNEL SELECT SWITCH

Select a transmission channel by using the rotary switch located on the front surface of the transmitter. Use a screwdriver to rotate the switch to the desired channel number.

HI/LOW OUTPUT POWER SWITCH

Select Hi or Low power by using the recessed power switch. Switching to Hi power is equal to 5 Watt output power. Switching to Low power is equal to 2 Watt output power.

MULTI I/O CONNECTOR

The multi I/O (6-pin Multi I/O) connector is mainly used as the video and external power input connector. It also provides access to many transmitter functions, such as:

- Programming the device
- Video in
- Power in
- Remote on
- Camera power

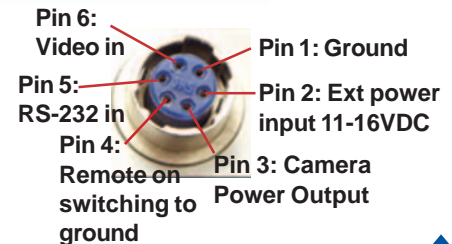
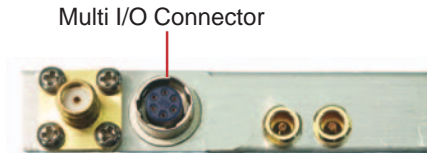
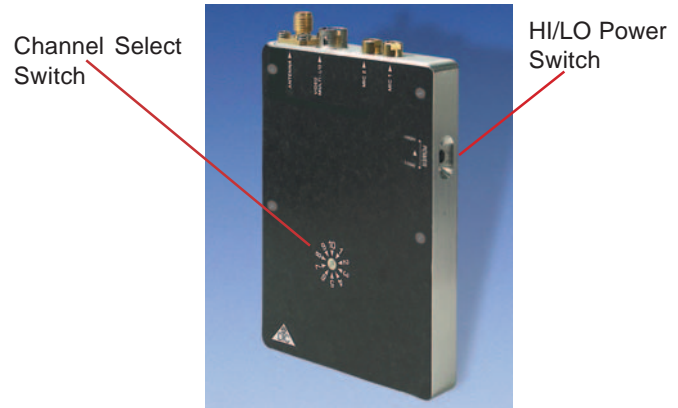

BASIC VIDEO TRANSMITTER

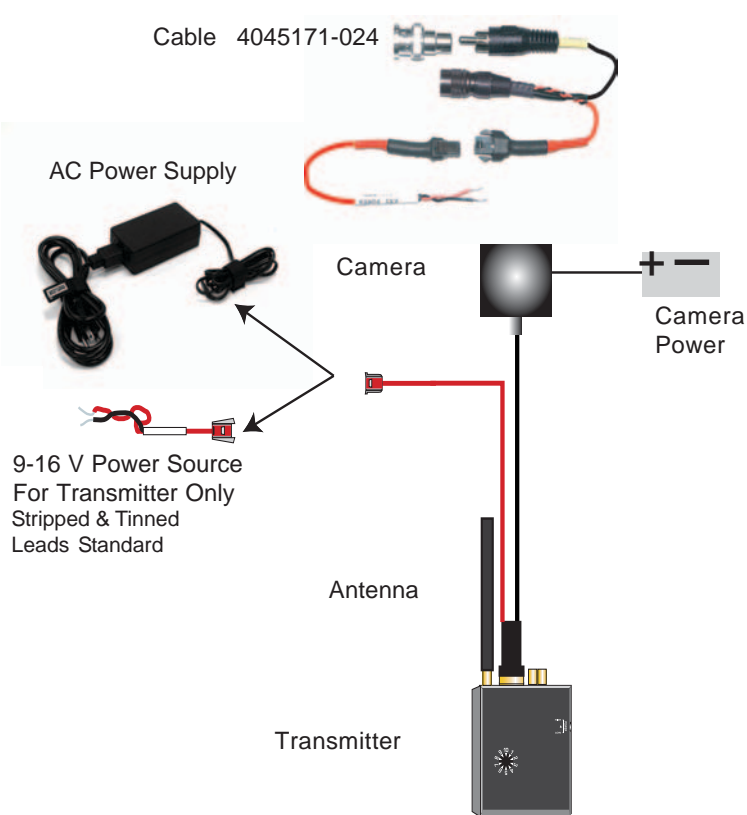

The basic VMS-5000 configuration consists of the video transmitter, dipole antenna, and DTC cable part number **4045171-024**. This cable is connected to the multi I/O port of the transmitter.

It is configured to supply:

- The video signal to the transmitter from the camera.
- Power to the transmitter through a molex connector that can easily be connected to DTC's battery pack. It also comes standard with stripped and tinned leads for a customer supplied power source. A recommended DTC battery pack is listed below and shown in the illustration:

- **4045177 (Optional D-Cell battery pack) Alkaline**

The cable does not supply power to the camera. The camera is powered separately with a customer-supplied power source. DTC offers other cables that will supply power to the camera as an option.

SINGLE POWER SOURCE

The VMS-5000 configuration, which uses the loop through power source for the camera, consists of the video transmitter, dipole antenna, and DTC cable part number **405189-024** . This cable is connected to the multi I/O port of the transmitter.

It is configured to supply:

- The video signal to the transmitter from the camera.
 - Power to the transmitter through a molex connector that can be easily connected to DTC's recommended battery pack.
 - Power to the camera through a molex connector that can easily be connected to DTC's optional cameras.
- **4045177 (Optional D-Cell battery pack) Alkaline**

☑ **NOTE:** You will need separate external camera power compatible with the camera you use unless:

- Voltage requirements are compatible with the 11-16 VDC requirements of the transmitter
- Camera current requirements do not exceed 200 mA
Your main external power supply provides adequate battery life

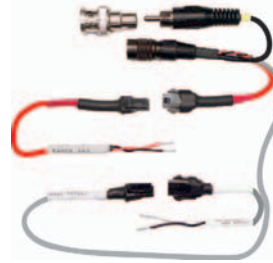

Cable 405189-024

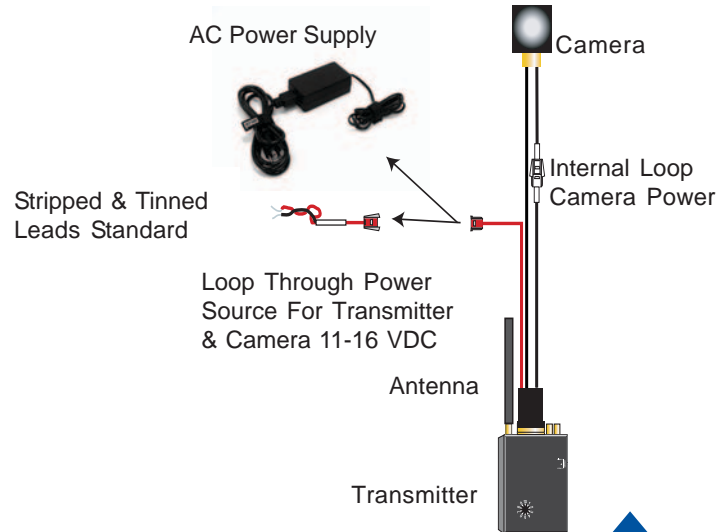

COMPONENTS



Part Number	Description
4045171-024	Video In/EXT Power/Cam. Power cable, 24"standard.

Specifications

Video In:	Multi I/O to RCA(M) with BNC adaptor (YELLOW)
Ext. Power:	24 AWG wire with a molex connector and stripped and tinned leads. (RED)

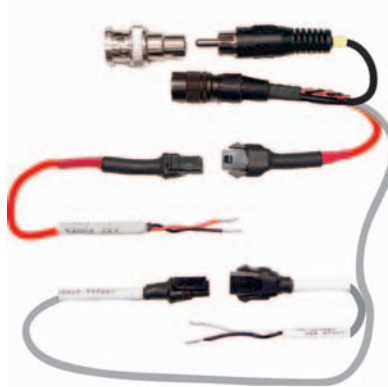

Part Number	Description
4045189-024	Video In/EXT Power/Cam. Power cable, 24"standard.

Specifications

Video In:	Multi I/O to RCA(M) with BNC adaptor (YELLOW)
Ext. Power:	24 AWG wire with a molex connector and stripped and tinned leads. (RED)
Camera Power:	24 AWG wire with a molex connector and stripped and tinned leads. (GRAY)



Part Number	Description
4045174-006	Antenna Cable 6" standard
4045174-012	Antenna Cable 12" Option

Specifications

Connectors	SMA to TNC
-------------------	------------



Part Number	Description
7011145-012	Microphone, 12" length
7011145-024	Microphone, 24" length
7011145-036	Microphone, 36" length
7011145-048	Microphone, 48" length
7011145-072	Microphone, 6' length
7011145-144	Microphone 12' length
7011145-360	Microphone 30' length



Part Number	Description
400023	12 Volt 2.5 Amp Power Supply 100-240 VAC input



Part Number	Description
4045173	Programming cable (Connects from the Multi I/O connector to the DB9 connector) This cable plugs into COM1 or COM2, serial ports of a PC. It allows for the programming of the Video transmitter with the DTC Programming software.

COMPONENTS

TO CLOSE:
PUSH CONNECTORS TOGETHER UNTIL THE MOLEX LOCKING MECHANISM CLICKS AND LOCKS

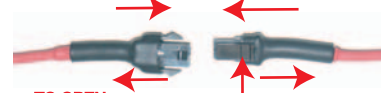

TO OPEN:
PUSH THIS TAB DOWN TO RELEASE THE MOLEX LOCKING MECHANISM, THEN PULL CONNECTORS APART.



Part Number	Description
8590138	Terminal, Crimp, Female, micro-fit (3.0) wire size 20-24 AWG plt gold. Molex Part# 43030-0009
8550104	Receptacle, 2 circuit, micro-fit (3.0) in line. Molex Part# 43645-0200
Part Number	Description
8590139	Terminal, Crimp, Male, Micro-fit (3.0) wire size 20-24 AWG plt. gold. Molex Part # 43031-0009
8550101	Plug, 2 circuit, Micro-fit (3.0) In line. Molex Part# 43640-0200

COMPONENTS



Part Number	Description
ANT-VIS	Dipole Antenna 2.4-2.5 GHz with right angle SMA adaptor
The ANT-VIS is a 1/2 wave coaxial dipole portable duck antenna. It can be mounted directly to the video transmitter, or at a right angle using the adaptor provided.	



Part Number	Description
VMS-5000-ENL	The 5Watt - 2Watt Transmitter with Encryption
VMS-5000	The 5Watt - 2Watt Transmitter

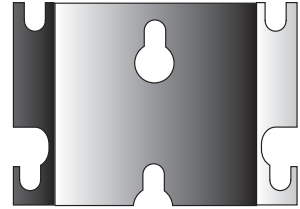

Part Number	Description
1088518	Optional Mounting Bracket
1087456	Captive Screw-No Encryption (4)
1087457	Captive Screw-With Encryption (4)



Part Number	Description
1088307	The 5Watt - 2Watt Heatsink



Introduction

DTC has built in a lot of flexibility in the programming options you have on the VMS series transmitters. You can choose to use some, all or none of this flexibility.

When you order a VMS transmitter, DTC will factory program your frequencies at no additional charge to you. You may want to place a sticker over the rotary switch on the chassis, so users in the field don't attempt to change frequencies. This is often the best path for state and local agencies with limited frequencies available to them.

DTC will also provide you with free software and a free programming cable, enabling you to change your video frequencies and their associated audio sub-carriers. This is ideal if you often work with other agencies, or anticipate the equipment being used by a multi-jurisdictional task force. You can program up to ten channel settings per unit. In general, this allows you to program most variations you might encounter in the field at the depot level.

As a practical matter, your VMS transmitter's video frequencies and audio sub-carriers will be dictated by the frequency and sub-carriers(s) of your receiver and/or repeater. In many cases, these devices are crystal controlled or have few channel options.

+ **TIP:** Make sure that you program your transmitter to match the frequencies and audio sub-carriers on your receiver, and test the components as a system prior to going into the field!

PROGRAMMING

Installing DTC Universal Programming Software on your PC

✓ **NOTE:** Uninstall any previous versions by going to Add/Remove Programs, clicking on DTC Universal Programming, and clicking on uninstall.

- 1 Click on Start, click on run.
- 2 Click on the Browse button.
- 3 Click on or find your CD drive.
- 4 Install the JAVA Runtime Environment Application first (CD provided).
- 5 Follow the install wizard screens.
- 6 Install the Universal Programming software next (floppy provided).
- 7 Click on Start, click on run.
- 8 Click on the Browse Button.
- 9 Click on your floppy drive.
- 10 Double click on the setup.
- 11 The Mask References dialog box displays. Select NO for normal installation. Select YES to hide references to DTC (for covert operations).
- 12 Follow the install wizard screens.

Your programming software is installed.

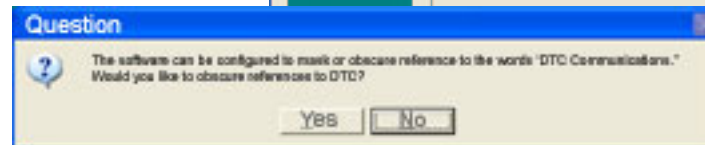
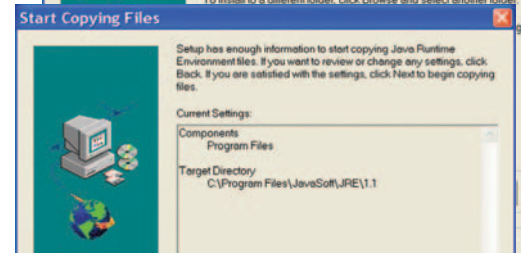
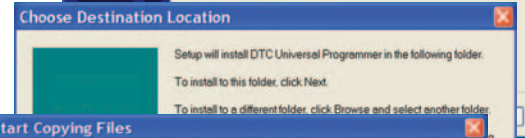
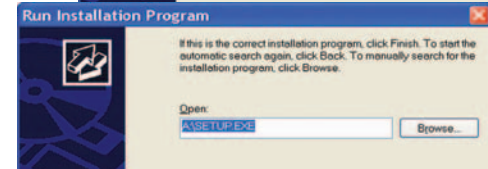

PROGRAMMING

- 1 Make sure that the power to the video transmitter is off.
- 2 Make sure the transmitter has an antenna installed into the antenna connector prior to programming.
- 3 Install the programming cable into the Multi I/O connector on the transmitter.
- 4 Plug the serial cable of the programming cable into the COM1 or COM2 port of your computer.
- 5 Connect the programming cable into a power source.
- 6 Select Start, programs, DTC communications on your computer.
- 7 The system allows you to select device COM1 or COM2, depending on which serial port you are connected to.
- 8 Follow the instructions on the DTC Universal Programming screens to begin the download process.

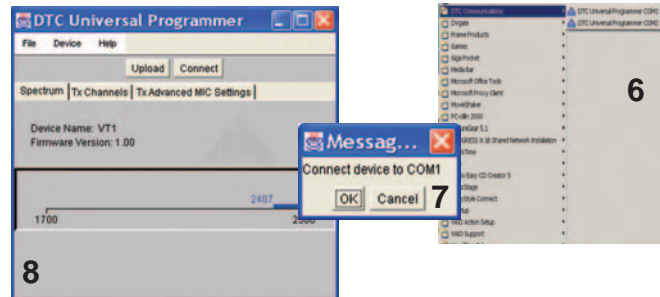
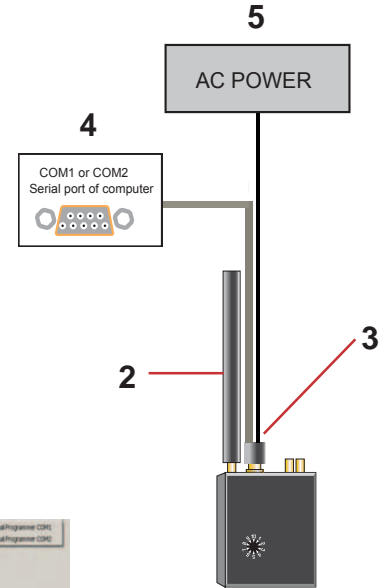

PROGRAMMING

- Click on the "Tx Channel" tab in the programmer screen.
- Select a channel and click on the Edit Channel button to change settings.
- Enter your new frequency and settings.
- To change any of the MIC-2 or MIC-1 settings, click on the settings provided, then click OK.
- Click on the Upload button to upload your new settings to the transmitter.

Your new settings have been installed.

The image displays three screenshots of the DTC Universal Programmer software interface, illustrating the steps to edit channel settings and upload them.

Top Screenshot (Step 9): Shows the main interface with the "Tx Channels" tab selected. A table lists channels with their frequencies and MIC settings. The "Upload" button is highlighted.

#	Frequency	MIC2_R	MIC1_L
1	1707.000	6.000000	6.500000
2	1775.000	6.000000	6.500000
3	1800.000	6.000000	6.500000
4	1825.000	6.000000	7.500000
5	1850.000	6.800000	6.800000
6	1750.000	7.500000	6.000000
7	1775.000	6.000000	7.500000
8	2500.000	6.800000	6.800000
9	2500.000	6.000000	6.000000

Middle Screenshot (Step 11): Shows the "Enter new Frequency" dialog box for Channel 1. The frequency is set to 1707.000 kHz. The dialog includes a grid for MIC settings and radio buttons for selection.

MIC2_R	MIC1_L
<input type="radio"/> 6.000000	<input type="radio"/> 6.000000
<input type="radio"/> 6.000000	<input type="radio"/> 6.000000
<input type="radio"/> 6.000000	<input type="radio"/> 6.000000
<input type="radio"/> 6.200000	<input type="radio"/> 6.200000
<input type="radio"/> 6.500000	<input checked="" type="radio"/> 6.500000
<input type="radio"/> 6.800000	<input type="radio"/> 6.800000
<input type="radio"/> 7.000000	<input type="radio"/> 7.000000
<input type="radio"/> 7.500000	<input type="radio"/> 7.500000
<input type="radio"/> 7.500000	<input type="radio"/> 7.500000
<input type="radio"/> 7.500000	<input type="radio"/> 7.500000

Bottom Screenshot (Step 12): Shows the "Tx Channels" tab with the "Edit MIC Frequency" button highlighted for channel 1.

The MIC frequencies on this screen can be changed to address mission requirements. Once these frequencies are changed, they become the topmost MIC frequencies seen when editing a channel in the Tx Channels tab. Edit these frequencies, only if the MIC frequencies you need are not available when editing a channel.

SPECIFICATIONS

General Specifications

Item	Specification
Power Input Voltage	External 11-16 Vdc
Power Consumption	18 Watts
Reverse Polarity Protection	YES
Chassis Dimensions	3.9 x 2.7 x 0.512"
Encryption Model	3.9 x 2.7 x 0.842"
HeatSink	2.88 x 1.825 x 4.375"
Available Camera Power	Dependent upon voltage supplied to the transmitter. Current limited to 200 mA.
Controls	10 channel select rotary switch Panel mounted, recessed slide power selection switch
Connectors	2 pin Lemo: Mic 1 2 pin Lemo: Mic 2 SMA: Antenna 6 pin Multi I/O: Video in, Data in, DC input 11-16 Vdc, camera power, Remote ON/OFF, Multiplexed Data out, Ground
Programmability	10 channels per selected band 250 KHz resolution steps Audio: User programmable from 6.0-7.5 MHz, in 10 kHz steps
Chassis notes	Machined, solid aluminum with rounded edges.
Environmental Factors	-30°C to +80°C Temperature 90% Humidity (non-condensing)

RF Specifications

Item	Specification
Operating Frequency	2450-2500 MHz, 250 KHz resolution steps
Power output	5.0 W max. @ nominal supply voltage, 25 Deg. C. -3db @ 7VDC ext. -2 dB over temp.
Output Impedance	50 Ohms
Spurs and Harmonics output	-50 dBc
Load Pull Stability	8:1 VSWR
Frequency Stability +/-	0.003%, -30 to +50°C
Modulation Sensitivity	8 MHz/V nom.
Modulation Sensitivity Variation	+/- 5% across the band
Peak Carrier Deviation	4 MHz nom.
Number of channels	10 max. (user programmable)
Sub-carrier sideband level	-28 dBc, +/- 2 dB

SPECIFICATIONS

Audio Specifications

Item	Specification
General	Mic level input (line level factory opt.) 50-3000 Hz Phased locked AGC on both inputs. Sub-carrier auto sensing, only active when microphone is attached.
Number of sub-carriers	2
Sub-carrier frequencies	6.0-7.5 MHz , user programmable
Sub-carrier ON/OFF Control	Subcarriers are activated when mic is connected.
Subcarrier Frequency Stability	+/- 0.003%, -30 to +70°C
Sub-Carrier Deviation	50 kHz peak
Audio S/N	45 dB min.
Frequency Response	BW1.5dB = 50-3000 Hz
Total Harmonic Distortion	<2%
Input Level	8 mVpp@400 Hz for 50 kHz peak dev.
Pre-Emphasis	75 μ S
Input Impedance	10k Ω

Video Specifications

Item	Specification
Video Frequency Response	BW1.5dB = 6 Hz - 5.0 MHz
Input Impedance	75 Ohms
Input Level	1Vp-p M
S/N	60 dB min.
Pre-Emphasis	Per CCIR 405 525 line curve
Differential Gain	5%

SPECIFICATIONS

Approximate VMS-5000 Current vs. External Supply Voltage
(Camera NOT included)

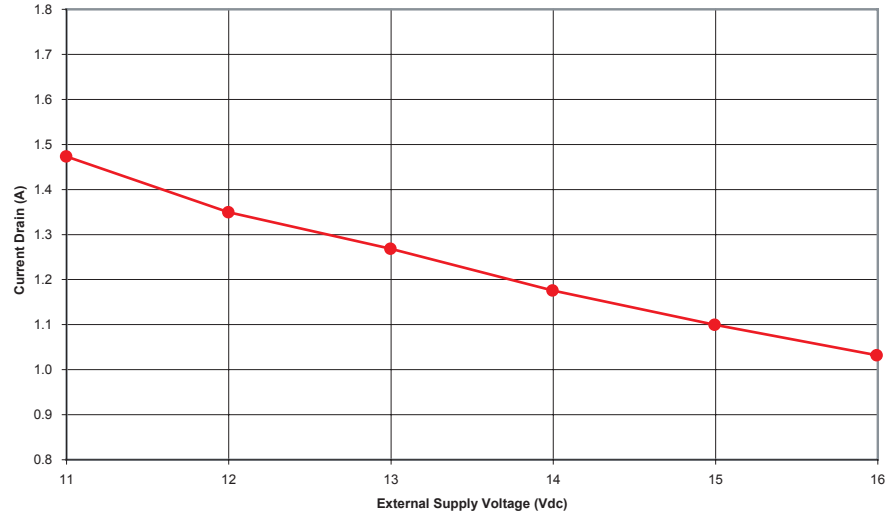

Battery Type	Part Number	Transmitter Only	Transmitter @ 5 W & Camera 12 V @ 180 mA
10 D Cell Alkaline Pack	4045177	7 hours	6 hours

FEATURES

The VMS transmitters are small module transmitters designed for off-body applications. They are part of a family of video transmitters from DTC that provide 250 mW, 2 Watts and 5 Watts output power.

Feature	Description
Programmable	User programmable video channels, selectable in 250 kHz steps. Two user programmable audio sub carriers, selectable in 10 kHz steps from 6 MHz to 7.5 MHz.
Audio Sub-Carriers	Audio sub carriers are OFF unless microphones are connected. The transmitter automatically senses when a microphone has been connected. The audio sub carriers are phase locked, and will not drift into the video signal. Automatic Gain Control is provided on each audio input, amplifying soft sounds.
Efficient Switching Power Supply	They generate far less heat than traditional video transmitters. They operate significantly longer than traditional video transmitters on the same power source.
External Power Loop Through	The power applied to the Multi I/O pin is automatically looped through the unit, and available on a second pin to power a remote device, such as a camera. If you apply 12 Volts in, you will get 12 Volts out, with a maximum current drain of 200mA
Encryption Options	The VMS series supports Ovation Micro ViewLock II™ encryption, which adds approximately 0.35" to the thickness of the unit.

Antenna Safety



Using Antennas with the VMS-5000 Video Transmitter

Use an antenna suitable for 5-Watt operation, however to ensure safe operation, it is imperative that proper spacing be maintained between the radiating surface of the antenna and any persons body. All RF category “Mobile” equipment must by law use a separation distance of 20 cm. The antenna supplied should not be placed closer than 20 cm (8in) to the body. To ensure that proper spacing is maintained, locate the transmitter or arrange physical barriers in such a way that people are prevented from approaching too closely. Limit your exposure to the antenna when the unit is in operation.



486 Amherst Street ■ Nashua, New Hampshire 03063 ■ 603-880-4411
www.dtccom.com