

## Integrated Transceiver Modules for WLAN 802.11 b/g/n, Bluetooth, Bluetooth Low Energy (BLE), and ANT

### FEATURES

- IEEE 802.11b,g,n,d,e,i compliant
- Typical WLAN Transmit Power:
  - 20.0dBm, 11 Mbps, CCK (b)
  - 14.5dBm, 54 Mbps, OFDM (g)
  - 12.5dBm, 65 Mbps, OFDM (n)
- Typical WLAN Sensitivity:
  - -89dBm, 8% PER, 11 Mbps
  - -76dBm, 10% PER, 54 Mbps
  - -73dBm, 10% PER, 65 Mbps
- Bluetooth 2.1+EDR, Power Class 1.5
- Full support for BLE 4.0 and ANT
- Miniature footprint: 18 mm x 13 mm
- Low height profile: 1.9 mm
- U.FL connector for external antenna
- Terminal for PCB/Chip antenna feeds
- Integrated band-pass filter
- Compact design based on Texas Instruments WL1271L Transceiver
- Seamless integration with TI OMAP™ application processors
- SDIO Host data path interfaces
- Bluetooth Advanced Audio Interfaces
- Low power operation mode
- RoHS compliant

### DESCRIPTION

The module is a high performance 2.4GHz IEEE 802.11 b/g/n, Bluetooth 2.1+EDR, and Bluetooth Low Energy (BLE) 4.0 radio in a cost effective, pre-certified footprint.

The module realizes the necessary PHY/MAC layers to support WLAN applications in conjunction with a host processor over a SDIO interface.

The module also provides a Bluetooth platform through the HCI transport layer. Both WLAN and Bluetooth share the same antenna port.

**MODULE FOOTPRINT AND PIN DEFINITIONS**

To apply the module, it is important to use the module pins in your application as they are designated in below and in the corresponding pin definition table found on pages 3 and 4. Not all the pins on the module may be used, as some are reserved for future functionality.

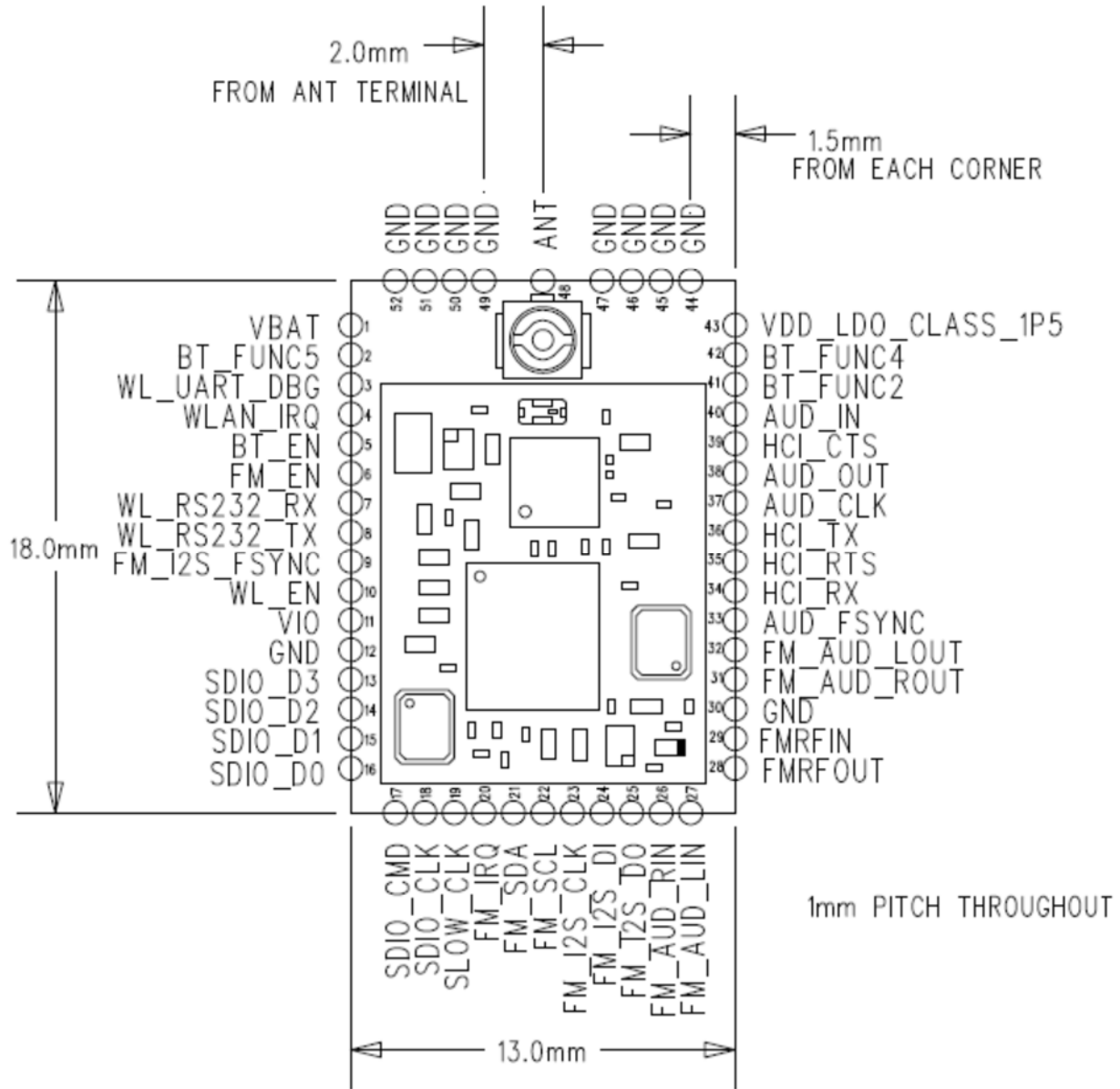

**Figure 1 Pinout (Top View)**

**PIN DESCRIPTIONS**

Module Pin	Name	I/O Type	Buffer Type	Logic Level	Description
1	VBAT	PI	-	-	Battery Voltage 3.6 VDC Nominal (3.0-4.8 VDC)
2	BT_FUNC5	DO	4 mA	1.8 VDC	HOST_WU (*)
3	WL_UART_DBG	DIO	4 mA	1.8 VDC	WL_UART_DBG
4	WLAN_IRQ	DO	4 mA	1.8 VDC	WLAN Interrupt Request
5	BT_EN	DI	-	1.8 VDC	Bluetooth Enable
6	FM_EN	DI	-	1.8 VDC	NOT SUPPORTED, CONNECT TO GND
7	WL_RS232_RX	DI	-	1.8 VDC	WLAN TEST UART RX (*)
8	WL_RS232_TX	DO	4 mA	1.8 VDC	WLAN TEST UART TX (*)
9	FM_I2S_FSYNC	DO	4 mA	1.8 VDC	NOT SUPPORTED, NO CONNECT
10	WL_EN	DI	-	1.8 VDC	WLAN Enable
11	VIO	PI	-	-	POWER SUPPLY FOR 1.8 VDC DIGITAL DOMAIN
12	GND	GND	-	-	Ground
13	SDIO_D3	DIO	8 mA	1.8 VDC	SDIO INTERFACE, HOST PULL UP
14	SDIO_D2	DIO	8 mA	1.8 VDC	SDIO INTERFACE, HOST PULL UP
15	SDIO_D1	DIO	8 mA	1.8 VDC	SDIO INTERFACE, HOST PULL UP
16	SDIO_D0	DIO	8 mA	1.8 VDC	SDIO INTERFACE, HOST PULL UP
17	SDIO_CMD	DIO	8 mA	1.8 VDC	HOST PULL UP
18	SDIO_CLK	DI	-	1.8 VDC	HOST PULL UP
19	SLOW_CLK	DI	-	1.8 VDC	SLEEP CLOCK (32 kHz)
20	FM_IRQ	DO	4 mA	1.8 VDC	NOT SUPPORTED, NO CONNECT
21	FM_SDA	DO	4 mA	1.8 VDC	NOT SUPPORTED, NO CONNECT
22	FM_SCL	DO	4 mA	1.8 VDC	NOT SUPPORTED, NO CONNECT
23	FM_I2S_CLK	DO	4 mA	1.8 VDC	NOT SUPPORTED, NO CONNECT
24	FM_I2S_DI	DI	4 mA	1.8 VDC	NOT SUPPORTED, CONNECT TO GND
25	FM_I2S_DO	DO	4 mA	1.8 VDC	NOT SUPPORTED, NO CONNECT
26	FM_AUD_RIN	AI	-	-	NOT SUPPORTED, CONNECT TO GND
27	FM_AUD_LIN	AI	-	-	NOT SUPPORTED, CONNECT TO GND
28	FMRFOUT	AO	-	-	NOT SUPPORTED, NO CONNECT
29	FMRFIN	AI	-	-	NOT SUPPORTED, CONNECT TO GND
30	GND	GND	-	-	Ground
31	FM_AUD_ROUT	AO	-	-	NOT SUPPORTED, NO CONNECT

# TRANSCEIVER MODULE DATASHEET

Module Pin	Name	I/O Type	Buffer Type	Logic Level	Description
32	FM_AUD_LOUT	AO	-	-	NOT SUPPORTED, NO CONNECT
33	AUD_FSYNC	DIO	4 mA	1.8 VDC	PCM I/F
34	HCI_RX	DI	8 mA	1.8 VDC	Bluetooth HCI UART RX (*)
35	HCI_RTS	DO	4 mA	1.8 VDC	Bluetooth HCI UART RTS (*)
36	HCI_TX	DIO	8 mA	1.8 VDC	Bluetooth HCI UART TX
37	AUD_CLK	DO	4 mA	1.8 VDC	PCM I/F (*)
38	AUD_OUT	DO	4 mA	1.8 VDC	PCM I/F (*)
39	HCI_CTS	DI	4 mA	1.8 VDC	Bluetooth HCI UART CTS (*)
40	AUD_IN	DI	4 mA	1.8 VDC	PCM I/F (*)
41	BT_FUNC2	DO	4 mA	1.8 VDC	Bluetooth Wakeup / DC2DC Mode (*)
42	BT_FUNC4	DO	4 mA	1.8 VDC	BT_UARTD (DEBUG) (*)
43	VDD_LDO_CLASS_1P5	NC	-	-	VBAT VOLTAGE PRESENT, NO CONNECT
44	GND	GND	-	-	Ground
45	GND	GND	-	-	Ground
46	GND	GND	-	-	Ground
47	GND	GND	-	-	Ground
48	ANT	RF		-	Antenna terminal for WLAN and Bluetooth (Note [1])
49	GND	GND	-	-	Ground
50	GND	GND	-	-	Ground
51	GND	GND	-	-	Ground
52	GND	GND	-	-	Ground

PI=Power Input    PO=Power Output    DI=Digital Input (1.8 VDC Logic Level)    DO=Digital Output (1.8 VDC Logic Level)  
 AI=Analog Input    AO=Analog Output    AIO = Analog Input/Output    RF= RF Port    GND=Ground

Note [1]: Antenna terminal presents d.c. short circuit to ground.

(\*) indicates that pin is capable of bidirectional operation, but is used as the type shown.

**Table 1 Module Pin Descriptions**

**All digital I/O signals use 1.8V logic. If the host microcontroller does not support 1.8V logic, then level shifters MUST be used.**

## ELECTRICAL SPECIFICATIONS

The majority of these characteristics are based on controlling and conditioning the tests using the control software application. Other control conditions may require these values to be re-characterized by the customer.

### Absolute Maximum Ratings

Parameter	Min	Max	Unit
Power supply voltage (VBAT) <sup>(4)(5)</sup>	-0.5	+5.5	V
Digital supply voltage (VIO)	-0.5	2.1	V
Voltage on any GPIO	-0.5	VIO + 0.5	V
Voltage on any Analog Pins <sup>(3)</sup>	-0.5	2.1	V
RF input power, antenna port		+10	dBm
Operating temperature <sup>(6)</sup>	-40	+85	°C
Storage temperature	-55	+125	°C

- Stresses beyond those listed under “absolute maximum ratings” may cause permanent damage to the device and are not covered by the warranty. These are stress ratings only and functional operation of the device at these or any other conditions beyond those indicated under “recommended operating conditions” is not implied. Exposure to absolute-maximum-rated conditions for extended periods may affect device reliability.
- All parameters are measured as follows unless stated otherwise: VDD\_IN=1.8V, VDDIO\_1.8V=1.8V, VDD\_LDO\_CLASS1P5=3.6V
- Analog pins: XTALP, XTALM, RFIOBT, DRPWRXBM, DRPWRXBP, DRPWTXB, and also FMRFINP, FMRFINM, FMRFINM, FMAUDLIN, FMAUDRIN, FMAUDLOUT, FMAUDROUT
- The following signals are from the VBAT group, PMS\_VBAT and VDD\_LDO\_CLASS1P5 (if BT class 1.5 direct VBAT is used).
- Maximum allowed depends on accumulated time at that voltage; 4.8V for 7 years lifetime, 5.5V for 6 hours cumulative.
- The device can be reliably operated for 5,000 active-WLAN cumulative hours at T<sub>A</sub> of 85°C.

**Table 2 Absolute Maximum Ratings**

### Recommended Operating Conditions

Parameter	Min	Typ	Max	Unit
V <sub>BAT</sub>	3.0	3.6	4.8	V
V <sub>IO</sub>	1.62	1.8	1.92	V
V <sub>IH</sub>	0.65 x V <sub>IO</sub>	-	V <sub>IO</sub>	V
V <sub>IL</sub>	0	-	0.35 x V <sub>IO</sub>	V
V <sub>OH</sub> @ 4, 8 mA	V <sub>IO</sub> -0.45	-	V <sub>IO</sub>	V
V <sub>OL</sub> @ 4, 8 mA	0	-	0.45	V
Ambient temperature range	-40	25	85	°C

**Table 3 Recommended Operating Conditions**

## General Characteristics

Parameter	Min	Typ	Max	Unit
WLAN RF frequency range	2412		2472	MHz
WLAN RF data rate	1	802.11 b/g/n rates supported	65	Mbps
BT RF frequency Range	2402		2480	MHz

**Table 4 General Characteristics**

## Power Consumption - WLAN

Parameter	Test Conditions	Min	Typ	Max	Unit
CCK (802.11b) TX Current	2437 MHz, $V_{BAT} = 3.6V$ , $T_{amb} = +25^{\circ}C$ $P_o = 20dBm$ , 11 Mbps CCK $L = 1200$ bytes, $t_{delay} (idle) = 4 \mu S$	-	280	-	mA
OFDM (802.11g) TX Current	2437 MHz, $V_{BAT} = 3.6V$ , $T_{amb} = +25^{\circ}C$ $P_o = 14.5 dBm$ , 54 Mbps OFDM $L = 1200$ bytes, $t_{delay} (idle) = 4 \mu S$	-	185	-	mA
OFDM (802.11n) TX Current	2437 MHz, $V_{BAT} = 3.6V$ , $T_{amb} = +25^{\circ}C$ $P_o = 12.5dBm$ , 65 Mbps OFDM $L = 1200$ bytes, $t_{delay} (idle) = 4 \mu S$	-	165	-	mA
CCK (802.11b) RX Current		-	100	-	mA
OFDM (802.11g) RX Current		-	100	-	mA
OFDM (802.11n) RX Current		-	100	-	mA
Dynamic Mode [1]		-	<1.2	-	mA

[1] Total Current from  $V_{BAT}$  for reception of Beacons with  $DTIM = 1$   $TBTT = 100$  mS, Beacon duration 1.6ms, 1 Mbps beacon reception in Listen Mode.

**Table 5 WLAN Power Consumption**

**Power Consumption - Bluetooth**

Parameter	Test Conditions	Min	Typ	Max	Unit
GFSK TX Current	Constant Transmit, DH5, PRBS9	-	45	-	mA
EDR TX Current	Constant Transmit, 2DH5,3DH5, PRBS9	-	43	-	mA
GFSK RX Current	Constant Receive, DH1	-	35	-	mA
EDR RX Current	Constant Receive, 2DH5, 3DH5	-	41	-	mA
Deep Sleep Current	Deep Sleep Mode	-	70	-	μA

**Table 6 Bluetooth Power Consumption**

**DC Characteristics – General Purpose I/O**

Parameter	Test Conditions	Min	Typ	Max	Unit
VIO Current			-	16	mA
Logic input low, $V_{IL}$		0	-	$0.35 \times V_{IO}$	V
Logic input high, $V_{IH}$		$0.65 \times V_{IO}$	-	$V_{IO}$	V
Logic output low, $V_{OL}$ (Full Drive)	$I_{out} = 8 \text{ mA}$	0	-	0.45	V
	$I_{out} = 4 \text{ mA}$	0	-	0.45	V
Logic output low, $V_{OL}$ (Reduced Drive)	$I_{out} = 1 \text{ mA}$	0	-	0.112	V
	$I_{out} = 0.09 \text{ mA}$	0	-	0.01	V
Logic output high, $V_{OH}$ (Full Drive)	$I_{out} = -8 \text{ mA}$	$V_{IO}-0.45$	-	$V_{IO}$	V
	$I_{out} = -4 \text{ mA}$	$V_{IO}-0.45$	-	$V_{IO}$	V
Logic output high, $V_{OH}$ (Reduced Drive)	$I_{out} = -1 \text{ mA}$	$V_{IO}-0.112$	-	$V_{IO}$	V
	$I_{out} = -0.3 \text{ mA}$	$V_{IO}-0.033$	-	$V_{IO}$	V

**Table 7 DC Characteristics General Purpose I/O**

**WLAN RF Characteristics**

**WLAN Transmitter Characteristics  
(TA=25°C, VBAT=3.6 V)**

Parameter	Test Conditions	Min	Typ	Max	Unit
11 Mbps CCK (802.11b) TX Output Power	11 Mbps CCK , 802.11(b) Mask Compliance, 35% EVM RMS power over TX packet	-	20	-	dBm
9 Mbps OFDM (802.11g) TX Output Power	9 Mbps OFDM , 802.11(g) Mask Compliance, -8 dB EVM RMS power over TX packet	-	19	-	dBm
54 Mbps OFDM (802.11g) TX Output Power	54 Mbps OFDM, 802.11(g) Mask Compliance, -25 dB EVM RMS power over TX packet	-	14.5	-	dBm
6.5 Mbps OFDM (802.11n) TX Output Power	6.5 Mbps OFDM, 802.11(n) Mask Compliance, -5 dB EVM RMS power over TX packet	-	19	-	dBm
65 Mbps OFDM (802.11n) TX Output Power	65 Mbps OFDM, 802.11(n) Mask Compliance, -28 dB EVM RMS power over TX packet	-	12.5	-	dBm

**Table 8 WLAN Transmitter RF Characteristics**



**WLAN Receiver Characteristics  
(TA=25°C, VBAT=3.6 V) [1]**

Parameter	Test Conditions	Min	Typ	Max	Unit
1 Mbps CCK (802.11b) RX Sensitivity	8% PER	-	-97	-	dBm
11 Mbps CCK (802.11b) RX Sensitivity	8% PER	-	-89	-	dBm
9 Mbps OFDM (802.11g) RX Sensitivity	10% PER	-	-90	-	dBm
54 Mbps OFDM (802.11g) RX Sensitivity	10% PER	-	-76	-	dBm
6.5 Mbps OFDM (802.11n) RX Sensitivity	10% PER	-	-91	-	dBm
65 Mbps OFDM (802.11n) RX Sensitivity	10% PER	-	-73	--	dBm
11 Mbps CCK (802.11b) RX Overload Level	8% PER	-	-	-10	dBm
6 Mbps OFDM(802.11g) RX Overload Level	10% PER	-	-	-20	dBm
54 Mbps OFDM(802.11g) RX Overload Level.	10% PER	-	-	-20	dBm
65 Mbps OFDM(802.11n) RX Overload Level	10% PER	-	-	-20	dBm

[1] Up to 2 dB degradation at Channel 13 for 11g/n modes and up to 2 dB degradation at Channel 14 for 11b/g/n modes.

**Table 9 WLAN Receiver RF Characteristics**

## Bluetooth RF Characteristics

### Bluetooth Transmitter GFSK Characteristics, Class 1.5 (TA=25°C, VBAT=3.6 V)

Parameter	Test Conditions	Min	Typ	Max	Bluetooth Spec	Unit
GFSK RF Output Power		-	9.5	-	-	dBm
EDR RF Output Power		-	7	-		dBm
Power Control Step Size		2	4	8	2-8	dB
EDR Relative Power		-2		1	-4/+1	dB

**Table 10 Bluetooth Transmitter RF Characteristics**

### Bluetooth Receiver Characteristics (TA=25°C, VBAT=3.6 V)

Parameter	Test Conditions	Min	Typ	Max	Bluetooth Spec	Unit
GFSK Sensitivity	BER=0.1%	-	-92	-	-70	dBm
EDR 2 Mbps Sensitivity	BER=0.01%	-	-91	-	-70	dBm
EDR 3 Mbps Sensitivity	BER=0.01%	-	-82	-	-70	dBm
GFSK Maximum Input Level	BER=0.1%	-	-5	-	-20	dBm
EDR 2 Maximum Input Level	BER=0.1%	-	-10	-	-	dBm
EDR 3 Maximum Input Level	BER=0.1%	-	-10	-	-	-

**Table 11 Bluetooth Receiver RF Characteristics**

## Bluetooth Low Energy RF Characteristics

### Bluetooth BLE Transmitter GMSK and EDR Characteristics, Class 1.5 (TA=25°C, VBAT=3.6 V)

Parameter	Test Conditions	Min	Typ	Max	BT Spec	Unit
GMSK RF Output Power		-	10	-	-	dBm
Power Control Step Size		2	4	8	2-8	dB

(1) BLE spec = 10dBm max can be achieved using normal system losses due to filters etc, or by reducing value through VS command.

**Table 12 Bluetooth Low Energy Transmitter RF Characteristics**

### Bluetooth BLE Receiver Characteristics (TA=25°C, VBAT=3.6 V)

Parameter	Test Conditions	Min	Typ	Max	BT Spec	Unit
GMSK Sensitivity	PER = 30.8%	-	-92	-	-70	dBm
GMSK Maximum Input Level	PER = 30.8%	-	-5	-	-20	dBm

**Table 13 Bluetooth Low Energy Receiver RF Characteristics**

## WLAN POWER-UP SEQUENCE

The following sequence describes device power-up from shutdown. Only the WLAN Core is enabled; the Bluetooth and FM cores are disabled.

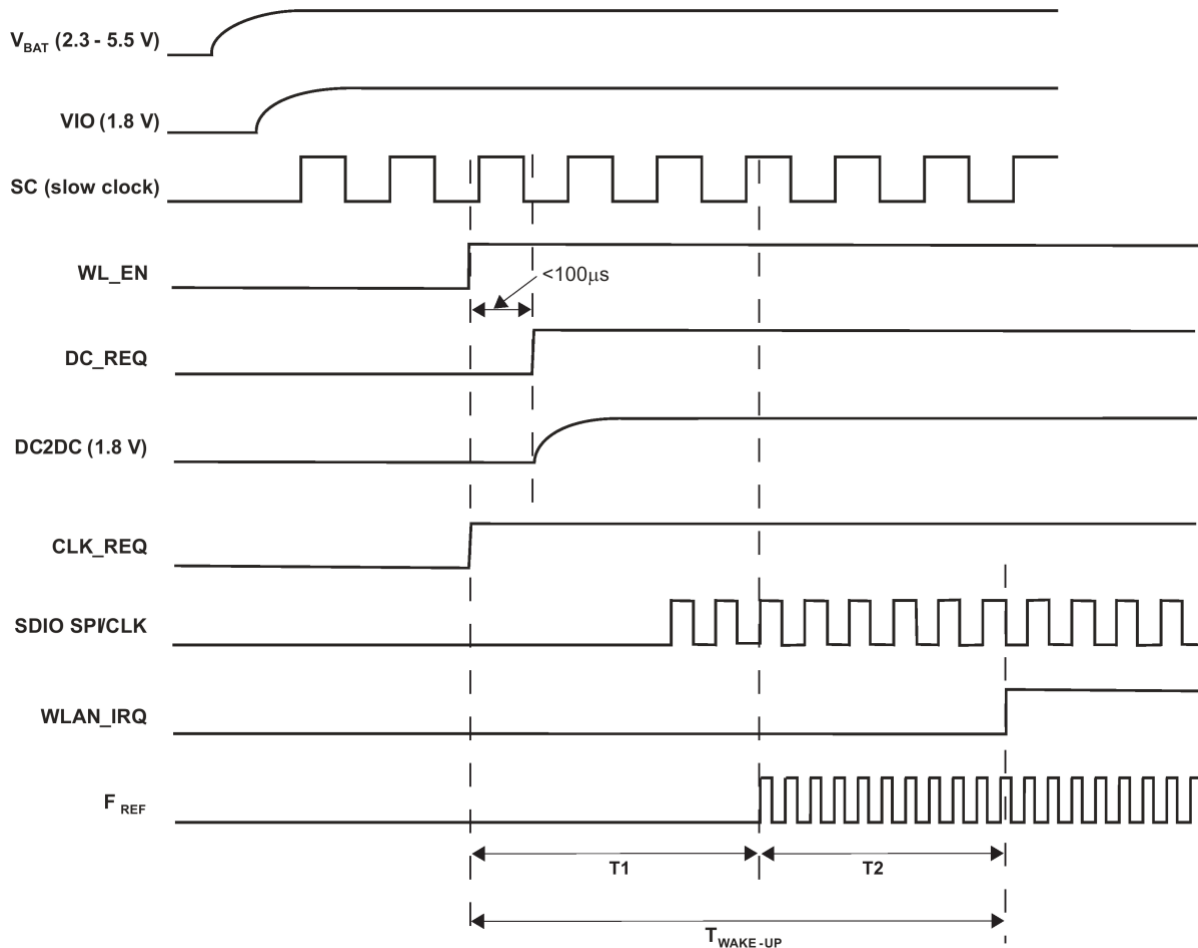

**Figure 2 Power-up Sequence Requirements**

1. No signals are allowed on the IO pins if no IO power is supplied, because the IOs are not 'failsafe'. Exceptions are CLK\_REQ\_OUT, SLOWCLK, XTALP, and AUD\_xxx, which are failsafe and can tolerate external voltages with no VDDs and DC2DC".
2. VBAT, VIO, and SLOWCLK must be available before WL\_EN.
3.  $T_{\text{wakeup}} = T_1 + T_2$

The duration of T<sub>1</sub> is defined as the time from WL\_EN=high until Fref is valid for the SoC. T<sub>1</sub>≈55ms

The duration of T<sub>2</sub> depends on:

- Operating system
- Host enumeration for the SDIO/WSPI
- PLL configuration
- Firmware download
- Releasing the core from reset
- Firmware initialization

## WLAN POWER-DOWN SEQUENCE

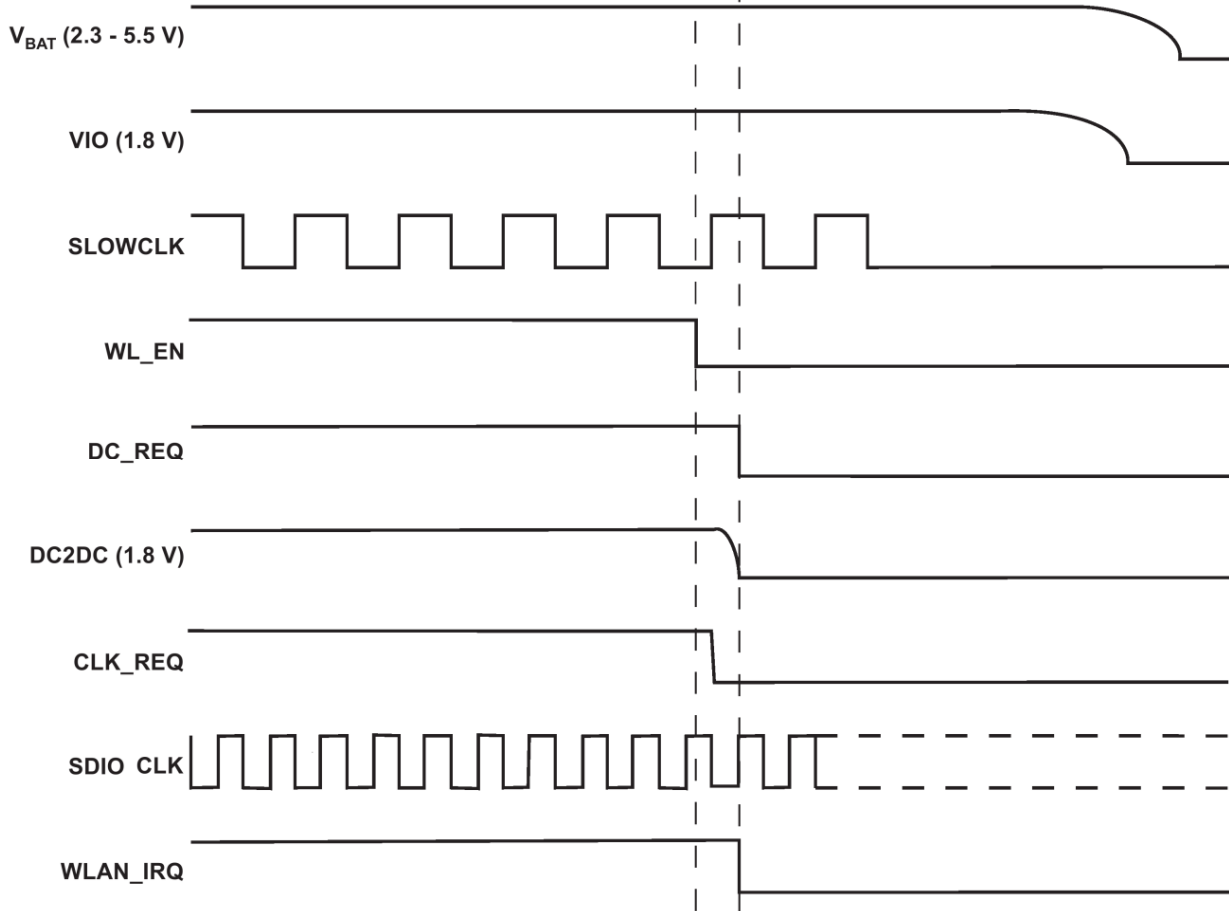

Notes:

1. The DC2DC(1.8V) signal can be monitored on BT\_FUNC2 Module Pin (#41)
2. DC\_REQ and CLK\_REQ are internal signals shown for reference only

**Figure 3 Module Power-down Sequence Requirements**

1. DC\_REQ will go low only if WLAN is the only core working. Otherwise if another core is working (e.g BT) it will stay high.
2. CLK\_REQ will go low only if WLAN is the only core working. Otherwise if another core is working and using the F<sub>REF</sub> (e.g BT) it will stay high.
3. If WLAN is the only core that is operating, WL\_EN must remain de-asserted for at least 64μsec before it is re-asserted.

## BLUETOOTH POWER-UP SEQUENCE

The following sequence describes device power up from shutdown. Only the Bluetooth core is enabled; the WLAN core is disabled.

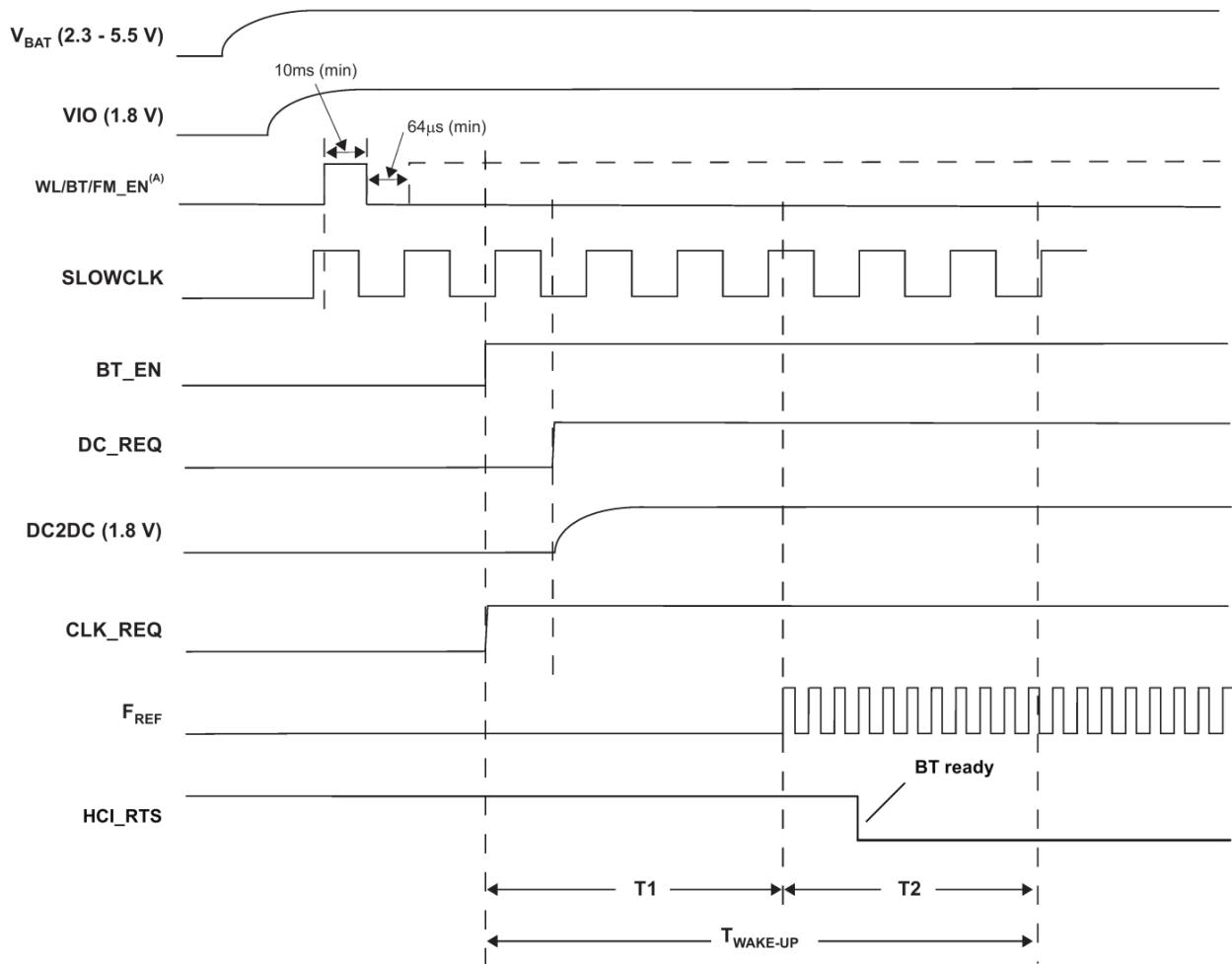

Notes:

1. (A) After this sequence is completed, the device is in the low VIO-leakage state while in shutdown
2. The DC2DC(1.8V) signal can be monitored on BT\_FUNC2 Module Pin (#41)
3. DC\_REQ, CLK\_REQ, and F<sub>REF</sub> are internal signals shown for reference only

**Figure 4 Bluetooth Power-up Sequence**

Power up requirements:

1. No signals are allowed on the IO pins if no IO power supplied, because the IOs are not 'failsafe'. Exceptions are CLK\_REQ\_OUT, SLOWCLK, XTALP, and AUD\_xxx, which are failsafe and can tolerate external voltages with no VDDSD and DC2DC.
2. VDDSD and SLOWCLK must be stable before releasing BT\_EN.
3. Fast clock must be stable maximum 55 ms after BT\_EN goes HIGH.

**BLUETOOTH POWER-DOWN SEQUENCE**

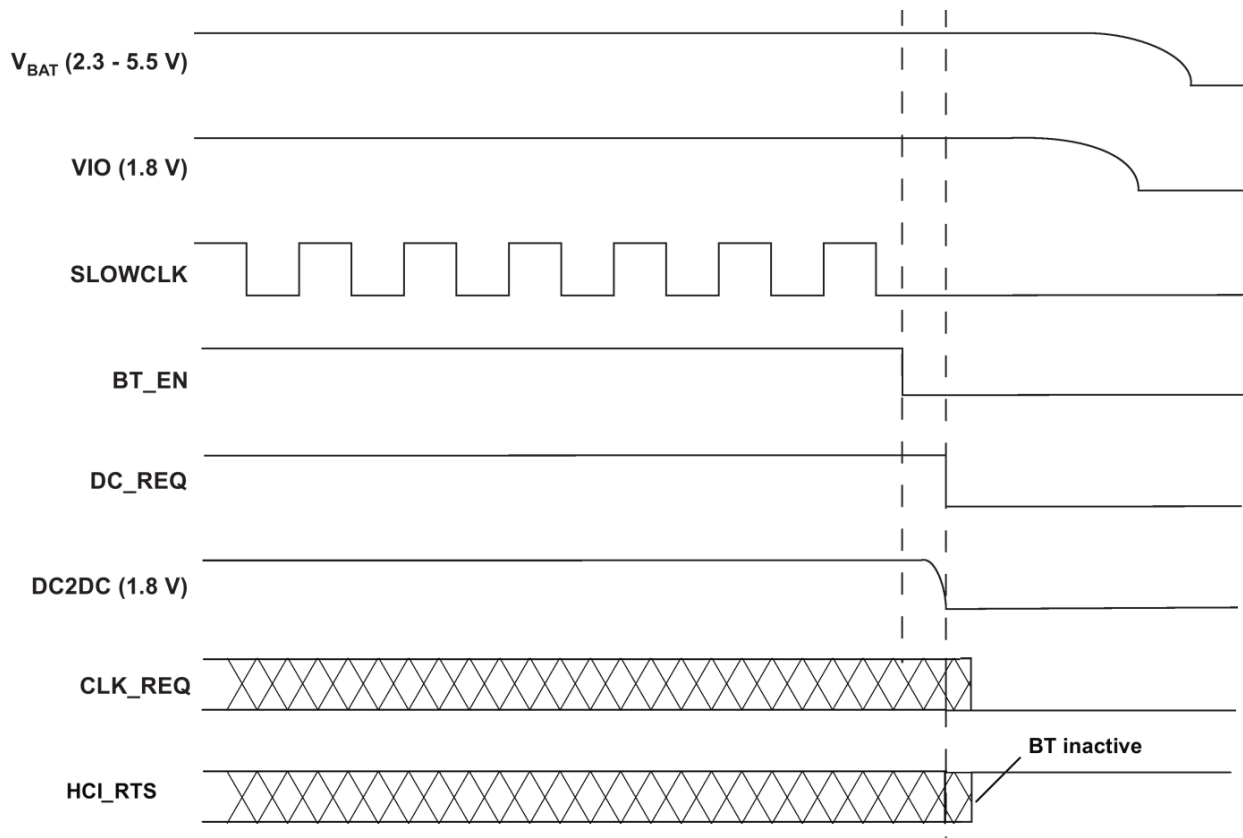

Notes:

1. The DC2DC(1.8V) signal can be monitored on BT\_FUNC2 Module Pin (#41)
2. DC\_REQ and CLK\_REQ are internal signals shown for reference only

**Figure 5 Bluetooth Power-down Sequence**

The module indicates completion of Bluetooth power up sequence by asserting HCI\_RTS low. This occurs up to 100 ms after BT\_EN goes high.

## ENABLE SCHEME

The module has 3 enable pins, one for each core: WL\_EN, and BT\_EN and FM\_EN. Presently, there are 2 modes of active operation now supported: WLAN and Bluetooth. It is recommended that the FM\_EN pin be grounded to disable the FM section. It is also recommended that the FM section be disabled by Bluetooth HCI commands.

1. Each core is operated independently by asserting each EN signal to Logic '1'. In this mode it is possible to control each core asynchronously and independently.
2. Bluetooth mode operation. WLAN will be operated through WL\_EN asynchronously and independently of Bluetooth.

## IRQ OPERATION

1. The default state of the WLAN\_IRQ prior to firmware initialization is 0.
2. During firmware initialization, the WLAN\_IRQ is configured by the SDIO module; a WLAN\_IRQ changes its state to 1.
3. A WLAN firmware interrupt is handled as follows:
  - a. The WLAN firmware creates an Interrupt-to-Host, indicated by a 1-to-0 transition on the WLAN\_IRQ line (host must be configured as active-low or falling-edge detect).
  - b. After the host is available, depending on the interrupt priority and other host tasks, it masks the firmware interrupt. The WLAN\_IRQ line returns to 1 (0-to-1 transition on the WLAN\_IRQ line).
  - c. The host reads the internal register status to determine the interrupt sources - the register is cleared after the read.
  - d. The host processes in sequence all the interrupts read from this register
  - e. The host unmask the firmware interrupts.
4. The host is ready to receive another interrupt from the WLAN device.



### **SLOW (32 KHZ) CLOCK SOURCE REQUIREMENTS**

The slow clock is always supplied from an external source. It is input on the SLOW\_CLK pin, and can be a digital signal in the range of VIO only. For slow clock frequency and accuracy refer to Table 14. The external slow clock must be stable before the system exits from shut down mode.

Parameter [1]	Condition	Symbol	Min	Typ	Max	Unit
Input slow clock frequency				32768		Hz
Input slow clock accuracy	WLAN, BT				+/-250	ppm
Input transition time $T_r/T_f$ – 10% to 90%		$T_r/T_f$			100	ns
Frequency input duty cycle			30	50	70	%
Input voltage limits	Square wave, DC coupled	$V_{IH}$	$0.65 \times V_{DD5}$		$V_{DD5}$	$V_{peak}$
$V_{IL}$	0		$0.35 \times V_{DD5}$			
Input impedance			1			MW
Input capacitance					5	pF
Rise and fall time					100	ns
Phase noise	1 kHz			-125		dBc/Hz

[1] Slow clock is a fail safe input

**Table 14 Slow Clock Source Requirements**

BLUETOOTH HCI UART

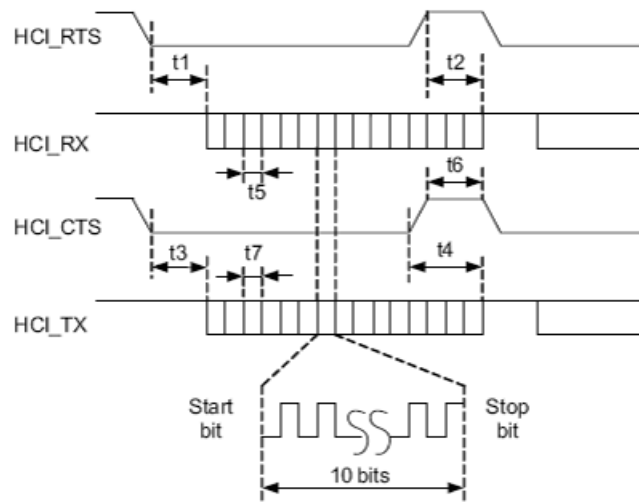

Figure 6 Bluetooth UART Timing

Symbol	Characteristics	Condition	Min	Typ	Max	Unit
	Baud rate	Most rates <sup>(1)</sup>	37.5		4000	kbps
t5, t7	Baud rate accuracy	Receive/Transmit			-2.5 to 1.5	%
t3	CTS low to TX_DATA on		0	2		μs
t4	CTS high to TX_DATA off	Hardware flow control			1	byte
t6	CTS-high pulse width		1			bit
t1	RTS low to RX_DATA on		0	2		μs
t2	RTS high to RX_DATA off	Interrupt set to 1/4 FIFO			16	byte
tb	Bit width (Jitter)		See application note <sup>(1)</sup>			% relative to ideal bit width

(1) Some exceptions: e.g. for 19.2-MHz max baud rate = 3.84 kbps.

Table 15 Bluetooth UART Timing

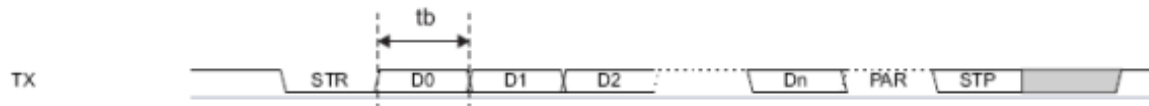

Figure 7 Bluetooth UART Data Frame

Symbol	Description
STR	Start bit
D0...Dn	Data bits (LSB first)
PAR	Parity bit (optional)
STP	Stop bit

Table 16 Bluetooth UART Data Frame

SDIO INTERFACE TIMING

PARAMETER		MIN	MAX	UNIT
$t_{CR}$	Delay time, assign relative address or data transfer mode	2	64	Clock cycles
$t_{CC}$	Delay time, CMD command valid to CMD command valid	58		Clock cycles
$t_{RC}$	Delay time, CMD response valid to CMD command valid	8		Clock cycles
$t_{AC}$	Access time, CMD command valid to SD3–SD0 read data valid	2		Clock cycles

Table 17 SDIO Interface Read (see Figure 8)

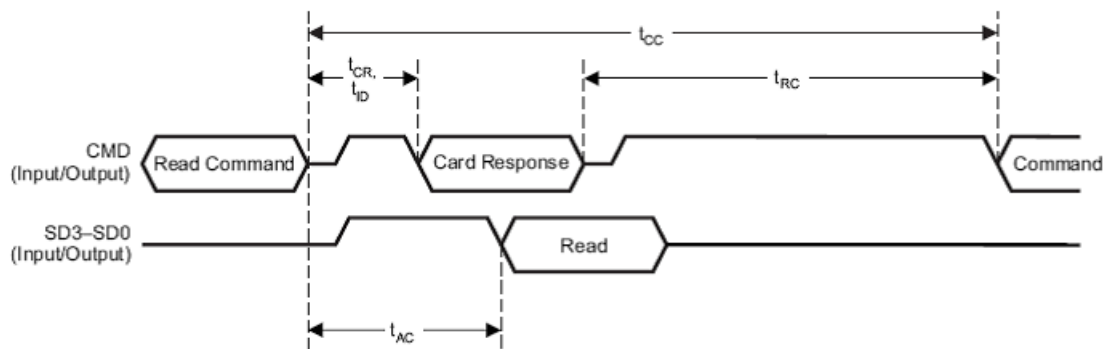
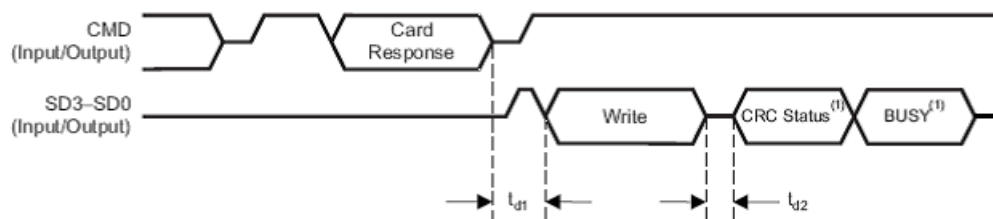

Figure 8 SDIO Single Block Read

PARAMETER		MIN	MAX	UNIT
$t_{d1}$	Delay time, CMD card response invalid to SD3–SD0 write data valid	2		Clock cycles
$t_{d2}$	Delay time, SD3–SD0 write data invalid end to CRC status valid	2	2	Clock cycles

Table 18 SDIO Interface Write (see Figure 9)



(1) CRC status and busy waveforms are only for data line 0. Data lines 1–3 are N/A. The busy waveform is optional, and may not be present.

Figure 9 SDIO Single Block Write

## SDIO CLOCK TIMING

Over Recommended Operating Conditions

**Note:** all timing parameters are indicated for the maximum Host-interface clock frequency.

PARAMETER			MIN	MAX	UNIT
$f_{clock}$	Clock frequency, CLK	$C_L \leq 30$ pF	0	26	MHz
DC	Low/high duty cycle	$C_L \leq 30$ pF	40	60	%
$t_{TLH}$	Rise time, CLK	$C_L \leq 30$ pF		4.3	ns
$t_{THL}$	Fall time, CLK	$C_L \leq 30$ pF		3.5	ns
$t_{ISU}$	Setup time, input valid before CLK $\uparrow$	$C_L \leq 30$ pF	4		ns
$t_{IH}$	Hold time, input valid after CLK $\uparrow$	$C_L \leq 30$ pF	5		ns
$t_{ODLY}$	Delay time, CLK $\downarrow$ to output valid	$C_L \leq 30$ pF	2	12	ns

Table 19 SDIO Clock Timing

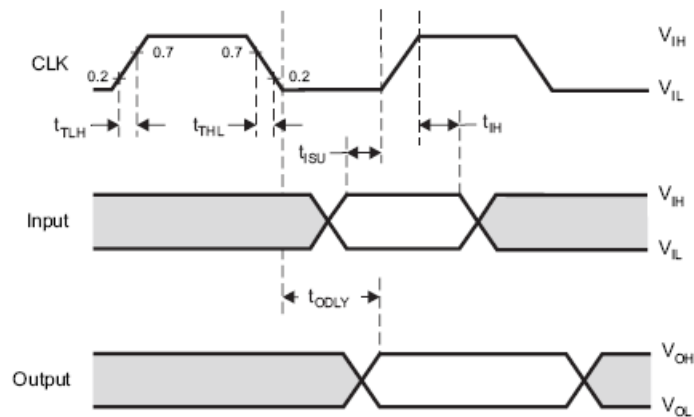
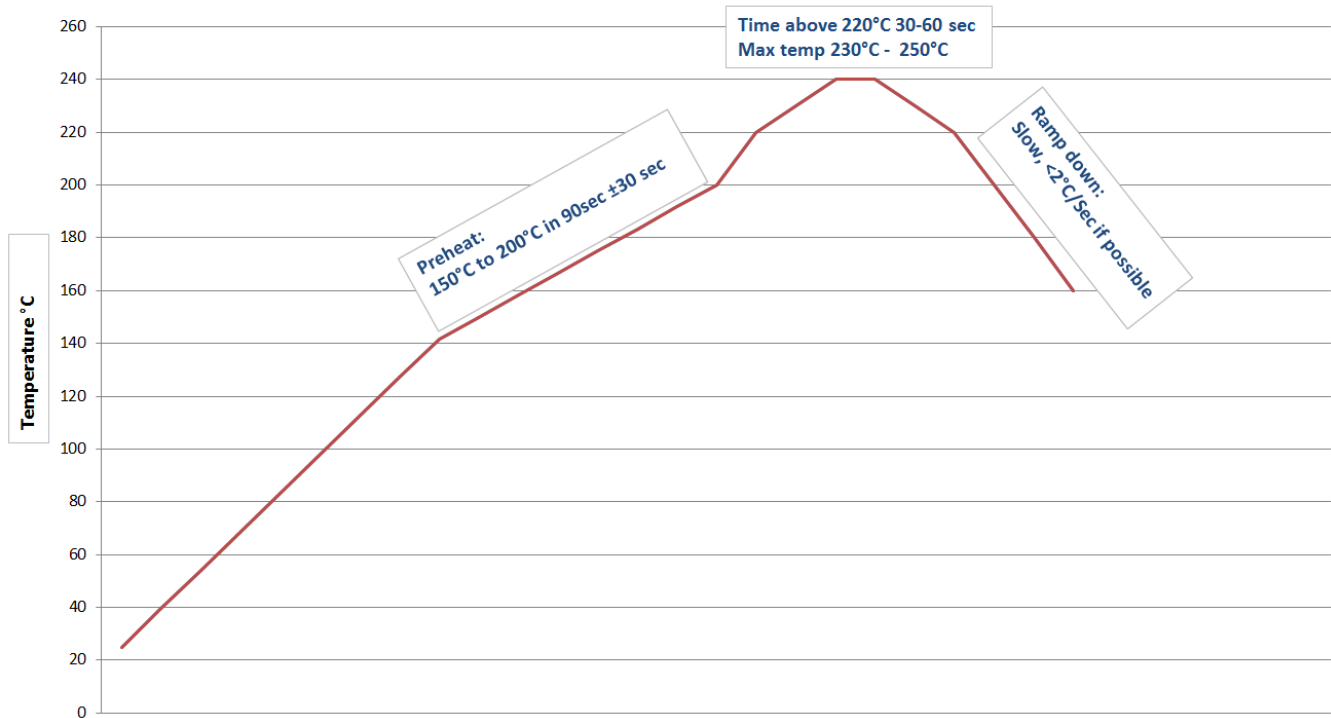

Figure 10 SDIO Clock Timing

## SOLDERING RECOMMENDATIONS

### Recommended Reflow Profile for Lead Free Solder



**Note: The quality of solder joints on the castellations ('half vias') where they contact the host board should meet the appropriate IPC Specification. See IPC-A-610-D Acceptability of Electronic Assemblies, section 8.2.4 Castellated Terminations."**

Figure 11 Reflow Profile

## CLEANING

In general, cleaning the populated modules is strongly discouraged. Residuals under the module cannot be easily removed with any cleaning process.

- Cleaning with water can lead to capillary effects where water is absorbed into the gap between the host board and the module. The combination of soldering flux residuals and encapsulated water could lead to short circuits between neighboring pads. Water could also damage any stickers or labels.
- Cleaning with alcohol or a similar organic solvent will likely flood soldering flux residuals into the RF shield, which is not accessible for post-washing inspection. The solvent could also damage any stickers or labels.
- Ultrasonic cleaning could damage the module permanently.

## OPTICAL INSPECTION

After soldering the Module to the host board, consider optical inspection to check the following:

- Proper alignment and centering of the module over the pads.
- Proper solder joints on all pads.
- Excessive solder or contacts to neighboring pads, or vias.

## REWORK

The module can be unsoldered from the host board if the Moisture Sensitivity Level (MSL) requirements are met as described in this datasheet.

**Never attempt a rework on the module itself, e.g. replacing individual components. Such actions will terminate warranty coverage.**

## SHIPPING, HANDLING, AND STORAGE

### Handling

The modules contain a highly sensitive electronic circuitry. Handling without proper ESD protection may destroy or damage the module permanently. ESD protection may destroy or damage the module permanently.

### Moisture Sensitivity Level (MSL)

Per J-STD-020, devices rated as MSL 4 and not stored in a sealed bag with desiccant pack should be baked prior to use.

After opening packaging, devices that will be subjected to reflow must be mounted within 72 hours of factory conditions (<30°C and 60% RH) or stored at <10% RH.

Bake devices for 48 hours at 125°C.

### Storage

Please use this product within 6 months after receipt. Any product used after 6 months of receipt needs to have solderability confirmed before use.

The product shall be stored without opening the packing under the ambient temperature from 5 to 35deg.C and humidity from 20 to 70%RH. (Packing materials, in particular, may be deformed at the temperatures above this range.)

Do not store in salty air or in an environment with a high concentration of corrosive gas, such as Cl<sub>2</sub>, H<sub>2</sub>S, NH<sub>3</sub>, SO<sub>2</sub>, or NOX.

Do not store in direct sunlight.

The product should not be subject to excessive mechanical shock.

### Repeating Reflow Soldering

Only a single reflow soldering process is encouraged for host boards.



## AGENCY CERTIFICATIONS

FCC ID: XOQTIWIBLECA, 15.247.

IC ID: 8521A-TIWIBLECA, RSS 210

Model:

## AGENCY STATEMENTS

### Federal Communication Commission Interference Statement

This equipment has been tested and found to comply with the limits for a Class B digital device, pursuant to Part 15 of the FCC Rules. These limits are designed to provide reasonable protection against harmful interference in a residential installation. This equipment generates, uses and can radiate radio frequency energy and, if not installed and used in accordance with the instructions, may cause harmful interference to radio communications. However, there is no guarantee that interference will not occur in a particular installation. If this equipment does cause harmful interference to radio or television reception, which can be determined by turning the equipment off and on, the user is encouraged to try to correct the interference by one of the following measures:

- Reorient or relocate the receiving antenna.
- Increase the separation between the equipment and receiver.
- Connect the equipment into an outlet on a circuit different from that to which the receiver is connected.
- Consult the dealer or an experienced radio/TV technician for help.

This device complies with Part 15 of the FCC Rules. Operation is subject to the following two conditions: (1) This device may not cause harmful interference, and (2) this device must accept any interference received, including interference that may cause undesired operation.

**FCC CAUTION: Any changes or modifications not expressly approved by the party responsible for compliance could void the user's authority to operate this equipment.**

### **Industry Canada Statements**

This device complies with Industry Canada License-exempt RSS standard(s). Operation is subject to the following two conditions: (1) this device may not cause interference, and (2) this device must accept any interference, including interference that may cause undesired operation of the device.

To reduce potential radio interference to other users, the antenna type and its gain should be so chosen that the equivalent isotropically radiated power (e.i.r.p.) is not more than that permitted for successful communication.

This device has been designed to operate with the antenna(s) listed below, and having a maximum gain of 1.3dBi (Johanson Chip). Antennas not included in this list or having a gain greater than 1.3 dBi are strictly prohibited for use with this device. The required antenna impedance is 50 ohms.

List of all Antennas Acceptable for use with the Transmitter

- 1) Johanson 2450AT43B100 chip antenna.

L'opération est soumise aux deux conditions suivantes: (1) cet appareil ne peut pas provoquer d'interférences et (2) cet appareil doit accepter toute interférence, y compris les interférences qui peuvent causer un mauvais fonctionnement de l'appareil.

Pour réduire le risque d'interférence aux autres utilisateurs, le type d'antenne et son gain doivent être choisis de manière que la puissance isotrope rayonnée équivalente (PIRE) ne dépasse pas celle permise pour une communication réussie.

Cet appareil a été conçu pour fonctionner avec l'antenne (s) ci-dessous, et ayant un gain maximum de 1,3 dBi (Johanson Chip). Antennes pas inclus dans cette liste ou d'avoir un gain supérieur à 1.3dBi sont strictement interdites pour l'utilisation avec cet appareil. L'impédance d'antenne requise est de 50 ohms.

Liste de toutes les antennes acceptables pour une utilisation avec l'émetteur

- 1) Antenne Johanson puce 2450AT43B100.

## OEM RESPONSIBILITIES TO COMPLY WITH FCC AND INDUSTRY CANADA REGULATIONS

The Module has been certified for integration into products only by OEM integrators under the following conditions:

This device is granted for use in Mobile only configurations in which the antennas used for this transmitter must be installed to provide a separation distance of at least 20cm from all person and not be co-located with any other transmitters except in accordance with FCC and Industry Canada multi-transmitter product procedures.

As long as the two conditions above are met, further transmitter testing will not be required. However, the OEM integrator is still responsible for testing their end-product for any additional compliance requirements required with this module installed (for example, digital device emissions, PC peripheral requirements, etc.).

**IMPORTANT NOTE:** In the event that these conditions cannot be met (for certain configurations or co-location with another transmitter), then the FCC and Industry Canada authorizations are no longer considered valid and the FCC ID and IC Certification Number cannot be used on the final product. In these circumstances, the OEM integrator will be responsible for re-evaluating the end product (including the transmitter) and obtaining a separate FCC and Industry Canada authorization.

Le module de a été certifié pour l'intégration dans des produits uniquement par des intégrateurs OEM dans les conditions suivantes:

Ce dispositif est accordé pour une utilisation dans des configurations mobiles seul dans lequel les antennes utilisées pour cet émetteur doit être installé pour fournir une distance de séparation d'au moins 20cm de toute personne et ne pas être colocalisés avec les autres émetteurs, sauf en conformité avec la FCC et de l'Industrie Canada, multi-émetteur procédures produit.

Tant que les deux conditions précitées sont réunies, les tests de transmetteurs supplémentaires ne seront pas tenus. Toutefois, l'intégrateur OEM est toujours responsable de tester leur produit final pour toutes les exigences de conformité supplémentaires requis avec ce module installé (par exemple, les émissions appareil numérique, les exigences de périphériques PC, etc.)

**NOTE IMPORTANTE:** Dans le cas où ces conditions ne peuvent être satisfaites (pour certaines configurations ou de co-implantation avec un autre émetteur), puis la FCC et Industrie autorisations Canada ne sont plus considérés comme valides et l'ID de la FCC et IC numéro de certification ne peut pas être utilisé sur la produit final. Dans ces circonstances, l'intégrateur OEM sera chargé de réévaluer le produit final (y compris l'émetteur) et l'obtention d'un distincte de la FCC et Industrie Canada l'autorisation.

## **OEM LABELING REQUIREMENTS FOR END-PRODUCT**

The module is labeled with its own FCC ID and IC Certification Number. The FCC ID and IC certification numbers are not visible when the module is installed inside another device, as such the end device into which the module is installed must display a label referring to the enclosed module. The final end product must be labeled in a visible area with the following:

**“Contains Transmitter Module FCC ID: XOQTIWIBLECA”**

**“Contains Transmitter Module IC: 8521A-TIWIBLECA”**

Or

**“Contains FCC ID: XOQTIWIBLECA”**

**“Contains IC: 8521A-TIWIBLECA”**

The OEM of the Module must only use the approved antenna(s) listed above, which have been certified with this module.

Le module de est étiqueté avec son propre ID de la FCC et IC numéro de certification. L'ID de la FCC et IC numéros de certification ne sont pas visibles lorsque le module est installé à l'intérieur d'un autre appareil, comme par exemple le terminal dans lequel le module est installé doit afficher une étiquette faisant référence au module ci-joint. Le produit final doit être étiqueté dans un endroit visible par le suivant:

**“Contient Module émetteur FCC ID: XOQTIWIBLECA ”**

**“Contient Module émetteur IC: 8521A-TIWIBLECA ”**

ou

**“Contient FCC ID: XOQTIWIBLECA ”**

**“Contient IC: 8521A-TIWIBLECA ”**

L'OEM du module ne doit utiliser l'antenne approuvée (s) ci-dessus, qui ont été certifiés avec ce module.

## **OEM END PRODUCT USER MANUAL STATEMENTS**

The OEM integrator should not provide information to the end user regarding how to install or remove this RF module or change RF related parameters in the user manual of the end product.

**The user manual for the end product must include the following information in a prominent location:**

This device is granted for use in Mobile only configurations in which the antennas used for this transmitter must be installed to provide a separation distance of at least 20cm from all person and not be co-located with any other transmitters except in accordance with FCC and Industry Canada multi-transmitter product procedures.

Other user manual statements may apply.

L'intégrateur OEM ne devrait pas fournir des informations à l'utilisateur final en ce qui concerne la façon d'installer ou de retirer ce module RF ou modifier les paramètres RF connexes dans le manuel utilisateur du produit final.

**Le manuel d'utilisation pour le produit final doit comporter les informations suivantes dans un endroit bien en vue:**

Ce dispositif est accordé pour une utilisation dans des configurations mobiles seule dans laquelle les antennes utilisées pour cet émetteur doit être installé pour fournir une distance de séparation d'au moins 20cm de toute personne et ne pas être co-localisés avec les autres émetteurs, sauf en conformité avec FCC et Industrie Canada, multi-émetteur procédures produit.

Autres déclarations manuel de l'utilisateur peuvent s'appliquer.