

ACQ550

User's Manual
ACQ550-U1 Drives (1...200 hp)



ABB

List of related manuals

GENERAL MANUALS

ACQ550-U1 User's Manual (1...200 hp)

- Safety
- Installation
- Start-up, control with I/O and ID Run
- Control panels
- Application macros
- Parameters
- Embedded fieldbus
- Fieldbus adapter
- Diagnostics
- Maintenance
- Technical data

Flange Mounting Instructions

Kit, IP21 / UL type 1	Frame size	Code (English)
FMK-A-R1	R1	100000982
FMK-A-R2	R2	100000984
FMK-A-R3	R3	100000986
FMK-A-R4	R4	100000988
AC8-FLNGMT-R5	R5	ACS800-
AC8-FLNGMT-R6	R6	PNTG01U-EN

Kit, IP54 / UL type 12	Frame size	Code (English)
FMK-B-R1	R1	100000990
FMK-B-R2	R2	100000992
FMK-B-R3	R3	100000994
FMK-B-R4	R4	100000996

OPTION MANUALS

(delivered with optional equipment)

OHDI-01 115/230 V Digital Input Module User's Manual
3AUA0000003101 (English)

OREL-01 Relay Output Extension Module User's Manual
3AUA0000001935 (English)

RCAN-01 CANopen Adapter User's Manual
3AFE64504231 (English)

RCCL-01 CC-Link Adapter Module User's Manual
3AUA0000061340 (English)

RCNA-01 ControlNet Adapter User's Manual
3AFE64506005 (English)

RDNA-01 DeviceNet Adapter User's Manual
3AFE64504223 (English)

RECA-01 EtherCAT Adapter Module User's Manual
3AUA0000043520 (English)

REPL-01 Ethernet POWERLINK Adapter Module User's Manual
3AUA0000052289 (English)

RETA-01 Ethernet Adapter Module User's Manual
3AFE64539736 (English)

RETA-02 Ethernet Adapter Module User's Manual
3AFE68895383 (English)

RPBA-01 PROFIBUS DP Adapter User's Manual
3AFE64504215 (English)

SREA-01 Ethernet Adapter User's Manual
3AUA0000042896 (English)

Typical contents

- Safety
- Installation
- Programming/Start-up
- Diagnostics
- Technical data

MAINTENANCE MANUALS

Guide for Capacitor Reforming in ACS50, ACS55, ACS150, ACS310, ACS320, ACS350, ACS550, ACH550 and ACQ550
3AFE68735190 (English)

BACnet is a registered trademark of ASHRAE.

CANopen is a registered trademark of CAN in Automation e.V.

CC-Link is a trademark of CC-Link Partner Association.

ControlNet™ is a trademark of ODVA™.

DeviceNet™ is a trademark of ODVA™.

DRIVECOM is a registered trademark of DRIVECOM User Group e.V.

EtherCAT is a registered trademark of Beckhoff.

EtherNet/IP™ is a trademark of ODVA™.

Modbus and Modbus/TCP are registered trademarks of Schneider Automation Inc.

PROFIBUS, PROFIBUS DP and PROFINET IO are registered trademarks of Profibus International.

ACQ550-U1 Drives
1...200 hp

User's Manual

3AUA0000145616 Rev C
EN
EFFECTIVE 3-15-2017

Safety

Use of warnings and notes

There are two types of safety instructions throughout this manual:

- Notes draw attention to a particular condition or fact, or give information on a subject.
- Warnings caution you about conditions which can result in serious injury or death and/or damage to the equipment. They also tell you how to avoid the danger. The warning symbols are used as follows:



Electricity warning warns of hazards from electricity which can cause physical injury and/or damage to the equipment.



General warning warns about conditions, other than those caused by electricity, which can result in physical injury and/or damage to the equipment.



WARNING! The ACQ550 adjustable speed AC drive should **ONLY** be installed by a qualified electrician.



WARNING! Even when the motor is stopped, dangerous voltage is present at the power circuit terminals U1, V1, W1 and U2, V2, W2 and, depending on the frame size, UDC+ and UDC-, or BRK+ and BRK-.



WARNING! Dangerous voltage is present when input power is connected. After disconnecting the supply, wait at least 5 minutes (to let the intermediate circuit capacitors discharge) before removing the cover.



WARNING! Even when power is switched off from the input terminals of the ACQ550, there may be dangerous voltage (from external sources) on the terminals of the relay outputs RO1...RO3.



WARNING! When the control terminals of two or more drives are connected in parallel, the auxiliary voltage for these control connections must be taken from a single source which can either be one of the drives or an external supply.



WARNING! Disconnect the internal EMC filter when installing the drive on an IT system (an ungrounded power system or a high-resistance-grounded [over 30 ohm] power system), otherwise the system will be connected to ground potential through the EMC filter capacitors. This may cause danger, or damage the drive.

Disconnect the internal EMC filter when installing the drive on a corner grounded TN system, otherwise the drive will be damaged.



Note: When the internal EMC filter is disconnected, the drive is not EMC compatible.

See section [Disconnecting the internal EMC filter](#) on page 23. Also see sections [IT systems](#) on page 276 and [Corner grounded TN systems](#) on page 275.



WARNING! Do not attempt to install or remove EM1, EM3, F1 or F2 screws while power is applied to the drive's input terminals.



WARNING! Do not control the motor with the disconnecting device (disconnecting means); instead, use the control panel start and stop keys  and , or commands via the I/O board of the drive. The maximum allowed number of charging cycles of the DC capacitors (i.e. power-ups by applying power) is five in ten minutes.



WARNING! The ACQ550-U1 is not field repairable. Never attempt to repair a malfunctioning drive; contact the factory or your local Authorized Service Center for replacement.



WARNING! The ACQ550 will start up automatically after an input voltage interruption if the external run command is on.



WARNING! The heat sink may reach a high temperature. See chapter [Technical data](#) on page 267.

Note: For more technical information, contact the factory or your local ABB representative.

Table of contents

List of related manuals

Safety

Use of warnings and notes	5
---------------------------------	---

Table of contents

Installation

Installation flow chart	11
Preparing for installation	12
Installing the drive	16

Start-up, control with I/O and ID Run

How to start up the drive	33
How to control the drive through the I/O interface	39
How to perform the ID Run	40

Control panel

W/WW control panel features	43
W/WW control panel modes	44

Application macros

ABB 2-wire macro	58
3-wire macro	59
Alternate macro	60
Motor Potentiometer macro	61
Hand-Auto macro	62
PID Control macro	63
PFC macro	64
Connection examples of two-wire and three-wire sensors	65
User parameter sets	66
Macro default values for parameters	67

Parameters

Complete parameter list	69
Complete parameter descriptions	83

Embedded fieldbus

Overview	177
Planning	178
Mechanical and electrical installation – EFB	179
Communication setup – EFB	181
Activate drive control functions – EFB	185
Feedback from the drive – EFB	190

Diagnostics – EFB	192
Modbus protocol technical data	197
ABB control profiles technical data	205
BACnet protocol technical data	217
Fieldbus adapter	
Overview	229
Planning	231
Mechanical and electrical installation – FBA	232
Communication set-up – FBA	233
Activate drive control functions – FBA	233
Feedback from the drive – FBA	236
Diagnostics – FBA	237
ABB Drives profile technical data	240
Generic profile technical data	248
Diagnostics	
Diagnostic displays	251
Correcting faults	252
Correcting alarms	258
Maintenance	
Maintenance intervals	261
Heatsink	261
Main fan replacement	262
Internal enclosure fan replacement	264
Capacitors	265
Control panel	265
Technical data	
Ratings	267
Input power connections	271
Motor connections	279
Brake components	285
Control connections	289
Efficiency	290
Cooling	291
Dimensions and weights	293
Degrees of protection	296
Ambient conditions	296
Materials	297
Applicable standards	299
CE marking	299
C-Tick marking	299
UL/CSA markings	300
IEC/EN 61800-3 (2004) Definitions	301
Compliance with the IEC/EN 61800-3 (2004)	301

Index**Further information**

Product and service inquiries	315
Product training	315
Providing feedback on ABB Drives manuals	315
Document library on the Internet	315

Installation

Study these installation instructions carefully before proceeding. **Failure to observe the warnings and instructions may cause a malfunction or personal hazard.**



WARNING! Before you begin read chapter [Safety](#) on page 5.

Note: The installation must always be designed and made according to applicable local laws and regulations. ABB does not assume any liability whatsoever for any installation which breaches the local laws and/or other regulations. Furthermore, if the recommendations given by ABB are not followed, the drive may experience problems that the warranty does not cover.

Installation flow chart

The installation of the ACQ550 adjustable speed AC drive follows the outline below. The steps must be carried out in the order shown. At the right of each step are references to the detailed information needed for the correct installation of the drive.

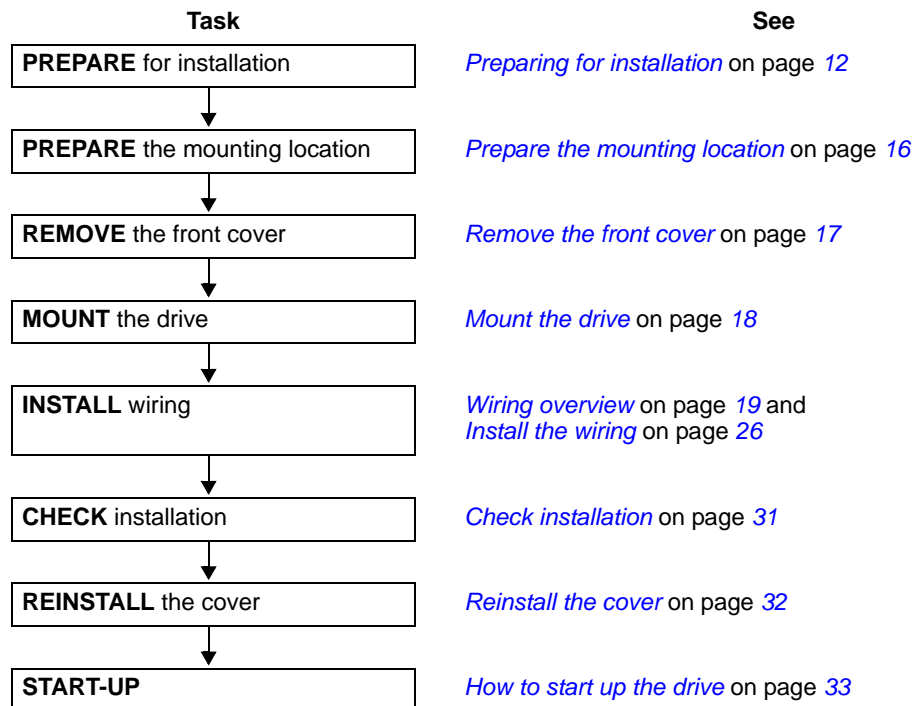

Preparing for installation

Lifting the drive

Lift the drive only by the metal chassis.



IP2040

Unpacking the drive

1. Unpack the drive.
2. Check for any damage and notify the shipper immediately if damaged components are found.
3. Check the contents against the order and the shipping label to verify that all parts have been received.

Drive identification

Drive labels

To determine the type of drive you are installing, refer to either:

- serial number label attached on upper part of the chokeplate between the mounting holes, or



- type designation label attached on the heat sink – on the right side of the drive cover. Two examples of the type designation label are given below.

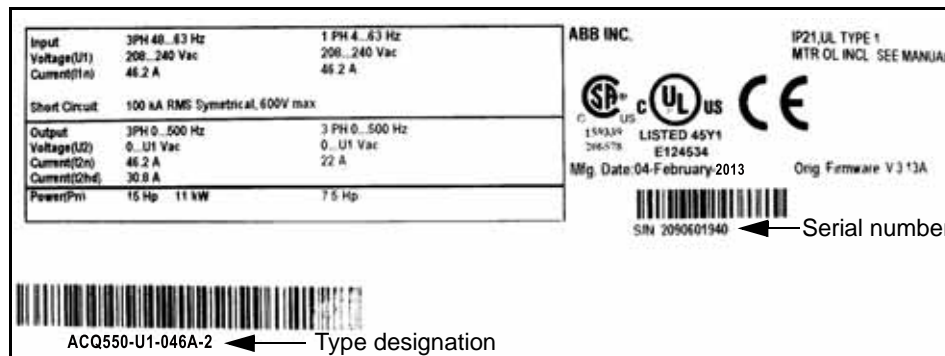
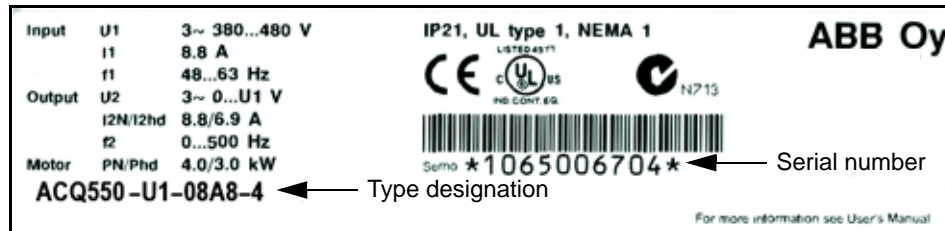

Type designation

Use the following chart to interpret the type designation found on both the type designation and the serial number label.

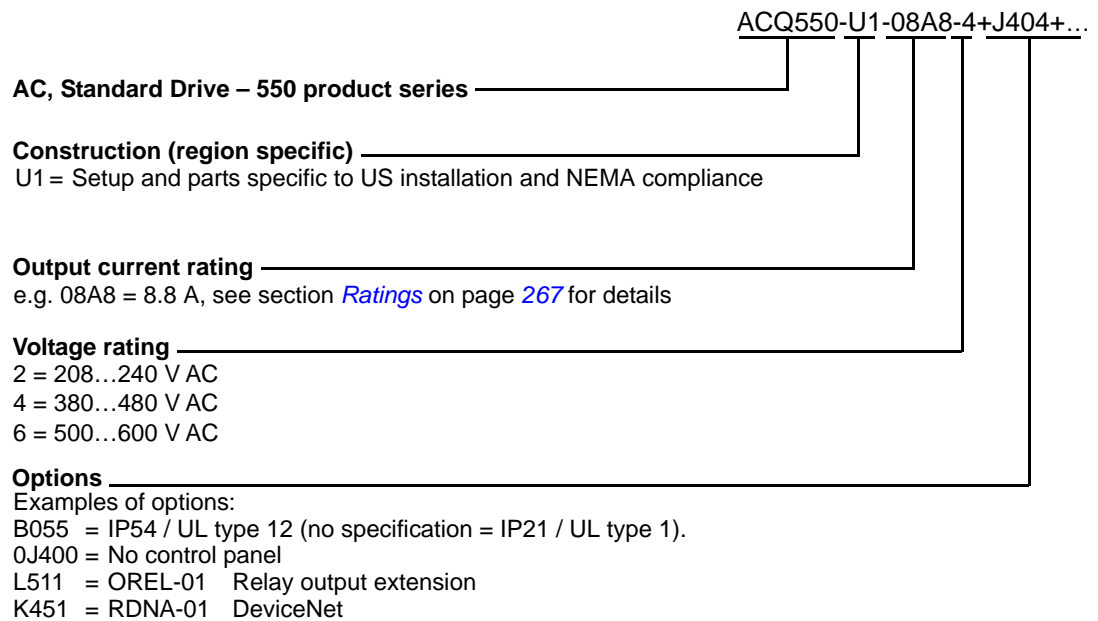

Ratings and frame size

The chart in section [Ratings](#) on page 267 lists technical specifications and identifies the drive's frame size – significant, since some instructions in this document vary, depending on the drive's frame size. To read the ratings table, you need the “Output current rating” entry from the type designation. Also, when using the ratings table, note that the table is broken into sections based on the drive's “Voltage rating”.

Serial number

The format of the drive serial number shown on the labels is described below.

Serial number is of format CYYWWXXXXX, where

C: Country of manufacture

YY: Year of manufacture

WW: Week of manufacture; 01, 02, 03, ... for week 1, week 2, week 3, ...

XXXXX: Integer starting every week from 00001.

Motor compatibility

The motor, drive and supply power must be compatible:

Motor specification	Verify	Reference
Motor type	3-phase induction motor	–
Nominal current	Motor value is within this range: $0.2 \dots 2.0 \cdot I_{2hd}$ (I_{2hd} = drive heavy duty current)	<ul style="list-style-type: none"> Type designation label on drive, entry for Output I_{2hd}, or Type designation on drive and rating table in chapter Technical data on page 267.
Nominal frequency	10...500 Hz	–
Voltage range	Motor is compatible with the ACQ550 voltage range.	208...240 V (for ACQ550-U1-XXXX-2) or 380...480 V (for ACQ550-U1-XXXX-4) or 500...600 V (for ACQ550-U1-XXXX-6)
Insulation	500...600 V drives: Either the motor complies with NEMA MG1 Part 31, or a du/dt filter is used between the motor and drive.	For ACQ550-U1-XXXX-6

Tools required

To install the ACQ550 you need the following:

- screwdrivers (as appropriate for the mounting hardware used)
- wire stripper
- tape measure
- drill
- for installations involving ACQ550-U1, frame sizes R5 or R6 and IP54 / UL type 12 enclosures: punch for creating conduit mounting holes
- for installations involving ACQ550-U1, frame size R6: appropriate crimping tool for power cable lugs. See section [Power terminal considerations – R6 frame size](#) on page 277.
- mounting hardware: screws or nuts and bolts, four each. The type of hardware depends on the mounting surface and the frame size:

Frame size	Mounting hardware	
R1...R4	M5	#10
R5	M6	1/4 in
R6	M8	5/16 in

Suitable environment and enclosure

Confirm that the site meets the environmental requirements. To prevent damage prior to installation, store and transport the drive according to the environmental requirements specified for storage and transportation. See section [Ambient conditions](#) on page 296.

Confirm that the enclosure is appropriate, based on the site contamination level:

- IP21 / UL type 1 enclosure: The site must be free of airborne dust, corrosive gases or liquids, and conductive contaminants such as dripping water, condensation, carbon dust and metallic particles.
- IP54 / UL type 12 enclosure: This enclosure provides protection from airborne dust and light sprays or splashing water from all directions.
- If, for some reason, an IP21 drive needs to be installed without the conduit box or cover, or an IP54 drive without the conduit plate or hood, see the note in chapter [Technical data](#), page 300.

Suitable mounting location

Confirm that the mounting location meets the following constraints:

- The drive must be mounted vertically on a smooth, solid surface, and in a suitable environment as defined above. For horizontal installation, contact your local ABB representative for more information.
- The minimum space requirements for the drive are the outside dimensions (see section [Outside dimensions](#) on page 294), plus air flow space around the drive (see section [Cooling](#) on page 291).
- The distance between the motor and the drive is limited by the maximum motor cable length. See section [Motor connection specifications](#) on page 279.
- The mounting site must support the drive's modest weight. See section [Weight](#) on page 295.

Installing the drive



WARNING! Before installing the ACQ550, ensure the input power supply to the drive is off.

For flange mounting (mounting the drive in a cooling air duct), see the appropriate *Flange Mounting Instructions*:

Frame size	IP21 / UL type 1		IP54 / UL type 12	
	Kit	Code (English)	Kit	Code (English)
R1	FMK-A-R1	10000982	FMK-B-R1	10000990
R2	FMK-A-R2	10000984	FMK-B-R2	10000992
R3	FMK-A-R3	10000986	FMK-B-R3	10000994
R4	FMK-A-R4	10000988	FMK-B-R4	10000996
R5 ¹	AC8-FLNGMT-R5	ACS800-PNTG01U-EN	-	-
R6 ¹	AC8-FLNGMT-R6		-	-

¹ Not available in ACQ550-U1 IP54/UL type 12

Prepare the mounting location

The ACQ550 should only be mounted where all of the requirements defined in section [Preparing for installation](#) on page 12 are met.

1. Mark the position of the mounting holes with the help of the mounting template provided with the drive.
2. Drill the holes.

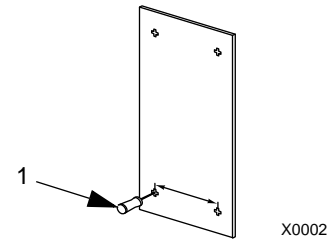

Note: Frame sizes R3 and R4 have four holes along the top. Use only two. If possible, use the two outside holes (to allow room to remove the fan for maintenance).

Note: ACS400 drives can be replaced using the original mounting holes. For R1 and R2 frame sizes, the mounting holes are identical. For R3 and R4 frame sizes, the inside mounting holes on the top of ACQ550 drives match ACS400 mounts.

Remove the front cover

IP21 / UL type 1

1. Remove the control panel, if attached.
2. Loosen the captive screw at the top.
3. Pull near the top to remove the cover.

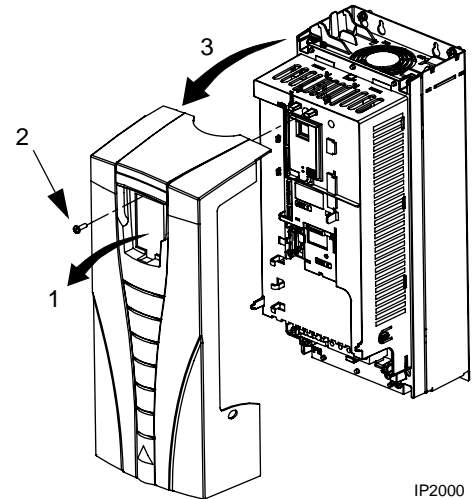

IP54 / UL type 12

1. If hood is present: Remove screws (2) holding hood in place.
2. If hood is present: Slide hood up and off of the cover.
3. Loosen the captive screws around the edge of the cover.
4. Remove the cover.

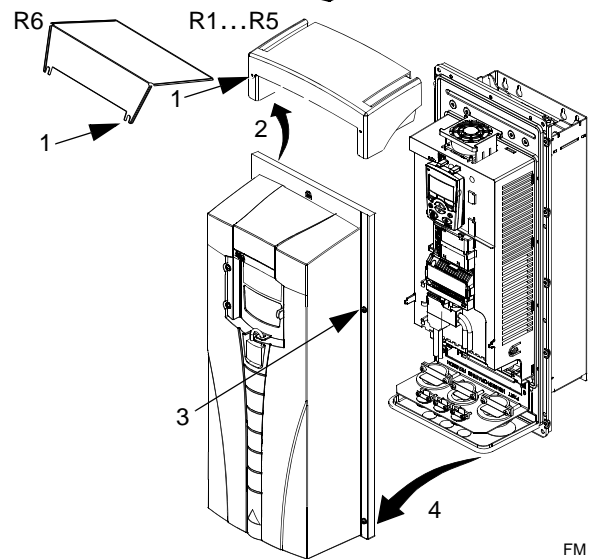

Mount the drive

IP21 / UL type 1

1. Position the ACQ550 onto the mounting screws or bolts and securely tighten in all four corners.

Note: Lift the ACQ550 by its metal chassis (frame size R6 by the lifting holes on both sides at the top).

2. Non-English speaking locations: Add a warning sticker in the appropriate language over the existing warning on the top of the module.

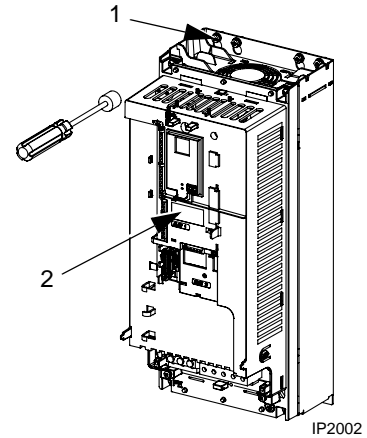

IP54 / UL type 12

For the IP54 / UL type 12 enclosures, rubber plugs are required in the holes provided for access to the drive mounting slots.

1. As required for access, remove the rubber plugs. Push plugs out from the back of the drive.
2. R5 & R6: Align the sheet metal hood (not shown) in front of the drive's top mounting holes. (Attach as part of next step.)
3. Position the ACQ550 onto the mounting screws or bolts and securely tighten in all four corners.

Note: Lift the ACQ550 by its metal chassis (frame size R6 by the lifting holes on both sides at the top).

4. Reinstall the rubber plugs.
5. Non-English speaking locations: Add a warning sticker in the appropriate language over the existing warning on the top of the module.

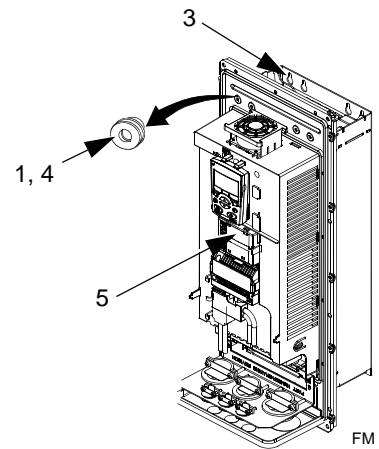

Wiring overview

Conduit/Gland kit

Wiring drives with the IP21 / UL type 1 enclosure requires a conduit/gland kit with the following items:

- conduit/gland box
- screws
- cover.

The kit is included with IP21 / UL type 1 enclosures.

Wiring requirements



WARNING! Ensure the motor is compatible for use with the ACQ550. The drive must be installed by a competent person in accordance with the considerations defined in section [Preparing for installation](#) on page 12. If in doubt, contact your local ABB sales or service office.

As you install the wiring, observe the following:

- There are four sets of wiring instructions – one set for each combination of drive enclosure type (IP21 / UL type and IP54 / UL type 12) and wiring type (conduit or cable). Be sure to select the appropriate procedure.
- Determine electro-magnetic compliance (EMC) requirements per local codes. See section [Motor cable requirements for CE & C-Tick compliance](#) on page 283. In general:
 - Follow local codes for cable size.
 - Keep these four classes of wiring separated: input power wiring, motor wiring, control/communications wiring and braking unit wiring.
- When installing input power and motor wiring, refer to the following, as appropriate:

Terminal	Description	Specifications and notes
U1, V1, W1 ¹	3-phase power supply input	Input power connections on page 271
PE	Protective Ground	Ground connections on page 275
U2, V2, W2	Power output to motor	Motor connections on page 279

¹ The ACQ550 -x1-xxxx-2 (208...240 V series) can be used with a single phase supply, if output current is derated by 50%. For single phase supply voltage, connect power at U1 and W1.

- To locate input power and motor connection terminals, see section [Power connection diagrams](#) on page 21. For specifications on power terminals, see section [Drive's power connection terminals](#) on page 276.
- For corner grounded TN systems, see section [Corner grounded TN systems](#) on page 275.
- For IT systems, see section [IT systems](#) on page 276.
- For frame size R6, see section [Power terminal considerations – R6 frame size](#) on page 277 to install the appropriate cable lugs.

- For drives using braking (optional), refer to the following, as appropriate:

Frame size	Terminal	Description	Braking accessory
R1, R2	BRK+, BRK-	Braking resistor	Braking resistor. See section Brake components on page 285.
R3, R4, R5, R6	UDC+, UDC-	DC bus	Contact your ABB representative to order either: <ul style="list-style-type: none"> • braking unit or • chopper and resistor

- When installing control wiring, refer to the following chapters or sections, as appropriate:
 - [Control terminals table](#) on page 24
 - [Control connections](#) on page 289
 - [Application macros](#) on page 57
 - [Complete parameter descriptions](#) on page 83
 - [Embedded fieldbus](#) on page 177
 - [Fieldbus adapter](#) on page 229.

Power connection diagrams

The following diagram shows the terminal layout for frame size R3, which, in general, applies to frame sizes R1...R6, except for the R5/R6 power and ground terminals.

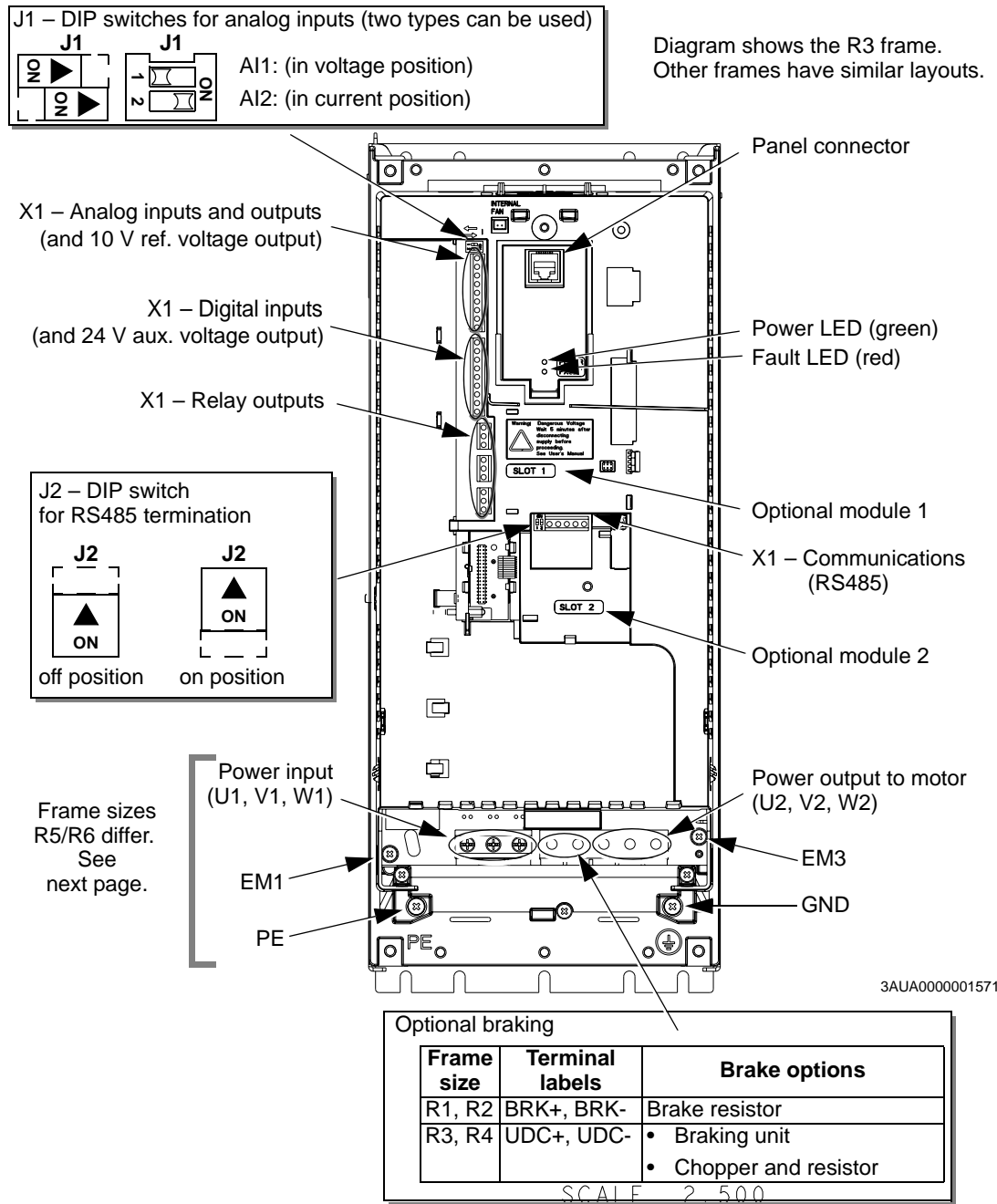

WARNING! To avoid danger, or damage to the drive, on IT systems and corner grounded TN systems, see section [Disconnecting the internal EMC filter](#) on page 23.

The following diagram shows the power and ground terminal layout for frame sizes R5 and R6.

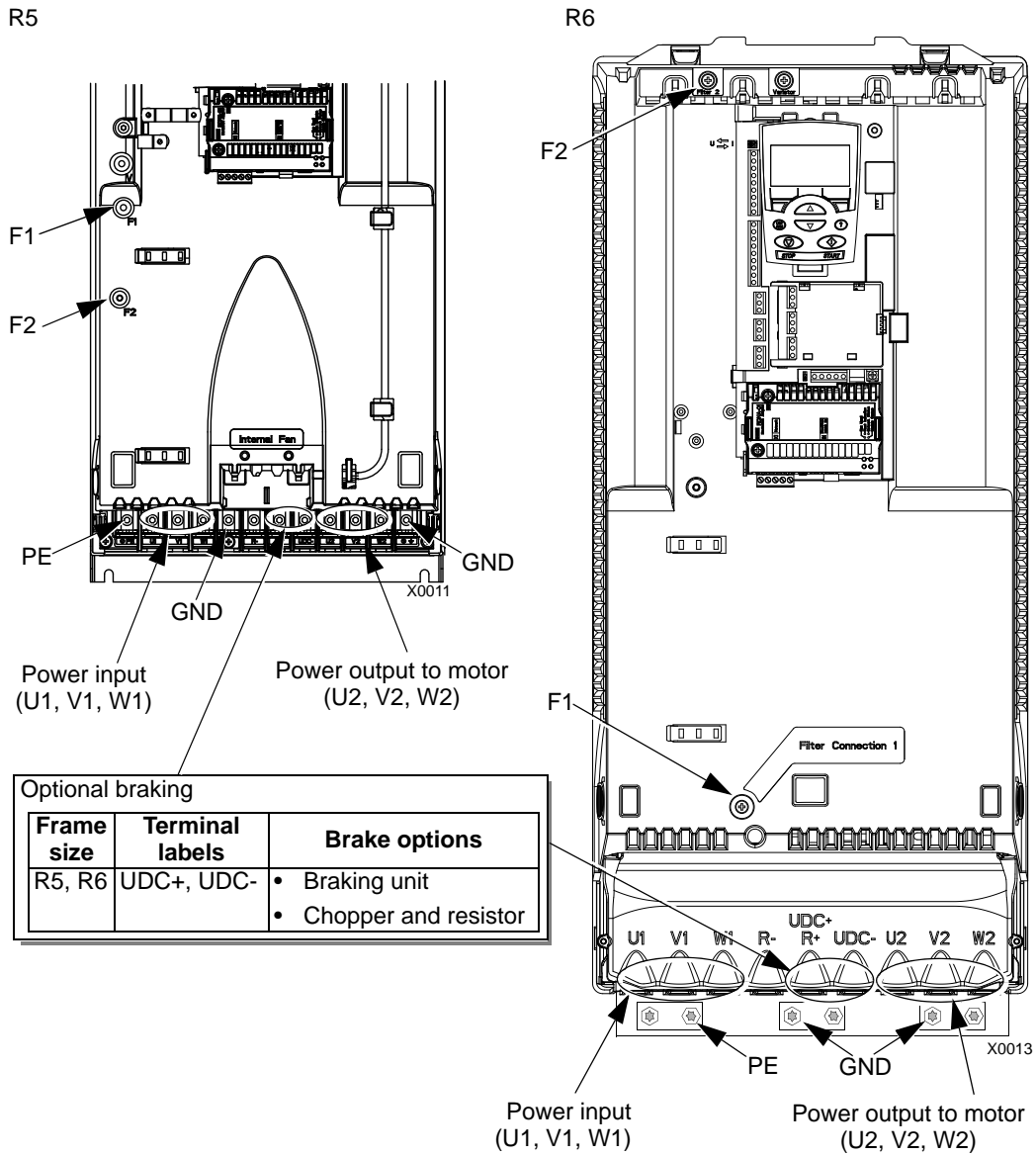

WARNING! To avoid danger, or damage to the drive, on IT systems and corner grounded TN systems, see section [Disconnecting the internal EMC filter](#) on page 23.

Disconnecting the internal EMC filter

On certain types of systems, you must disconnect the internal EMC filter, otherwise the system will be connected to ground potential through the EMC filter capacitors, which might cause danger, or damage the drive.

Note: When the internal EMC filter is disconnected, the drive is not EMC compatible.

The following table shows the installation rules for the EMC filter screws in order to connect or disconnect the filter, depending on the system type and the frame size. For more information on the different system types, see [IT systems](#) on page 276 and [Corner grounded TN systems](#) on page 275.

The locations of screws EM1 and EM3 are shown in the diagram on page 21. The locations of screws F1 and F2 are shown in the diagram on page 22.

Frame sizes	Screw	Symmetrically grounded TN systems (TN-S systems)	Corner grounded TN systems	IT systems (ungrounded or high-resistance-grounded [$> 30 \text{ ohm}$])
R1...R3	EM1	x	x	•
	EM3 ¹	x	•	•
R4	EM1	x	x	–
	EM3 ¹	x	–	–
R5...R6	F1	x	x	–
	F2	x	x	–

x = Install the screw. (EMC filter will be connected.)

• = Replace the screw with the provided polyamide screw. (EMC filter will be disconnected.)

– = Remove the screw. (EMC filter will be disconnected.)

¹ ACQ550-U1 drives are shipped with screw EM3 already removed.

Control terminals table

The following provides information for connecting control wiring at X1 on the drive.

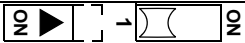
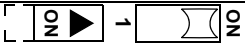
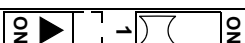
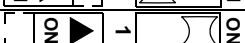
	X1	Hardware description		
Analog I/O	1	SCR Terminal for signal cable shield (screen). (Connected internally to chassis ground.)		
	2	AI1 Analog input channel 1, programmable. Default ² = frequency reference. Resolution 0.1%, accuracy $\pm 1\%$. Two different DIP switch types can be used. J1: AI1 OFF: 0...10 V ($R_i = 312 \text{ kohm}$)  NO J1: AI1 ON: 0...20 mA ($R_i = 100 \text{ ohm}$)  NO		
			3	AGND Analog input circuit common (connected internally to chassis gnd. through 1 Mohm).
			4	+10 V Potentiometer reference source: 10 V $\pm 2\%$, max. 10 mA ($1 \text{ kohm} \leq R \leq 10 \text{ kohm}$).
			5	AI2 Analog input channel 2, programmable. Default ² = not used. Resolution 0.1%, accuracy $\pm 1\%$. Two different DIP switch types can be used. J1: AI2 OFF: 0...10 V ($R_i = 312 \text{ kohm}$)  NO J1: AI2 ON: 0...20 mA ($R_i = 100 \text{ ohm}$)  NO
	6	AGND Analog input circuit common (connected internally to chassis gnd. through 1 Mohm).		
	7	AO1 Analog output, programmable. Default ² = frequency. 0...20 mA (load < 500 ohm). Accuracy $\pm 3\%$.		
	8	AO2 Analog output, programmable. Default ² = current. 0...20 mA (load < 500 ohm). Accuracy $\pm 3\%$.		
	9	AGND Analog output circuit common (connected internally to chassis gnd. through 1 Mohm).		
Digital inputs ¹	10	+24V Auxiliary voltage output 24 V DC / 250 mA (reference to GND), short circuit protected.		
	11	GND Auxiliary voltage output common (connected internally as floating).		
	12	DCOM Digital input common. To activate a digital input, there must be $\geq +10 \text{ V}$ (or $\leq -10 \text{ V}$) between that input and DCOM. The 24 V may be provided by the ACQ550 (X1-10) or by an external 12...24 V source of either polarity.		
	13	DI1 Digital input 1, programmable. Default ² = start/stop.		
	14	DI2 Digital input 2, programmable. Default ² = fwd/rev.		
	15	DI3 Digital input 3, programmable. Default ² = constant speed sel (code).		
	16	DI4 Digital input 4, programmable. Default ² = constant speed sel (code).		
	17	DI5 Digital input 5, programmable. Default ² = ramp pair selection (code).		
18	DI6 Digital input 6, programmable. Default ² = not used.			

		X1	Hardware description	
Relay outputs	19	RO1C		Relay output 1, programmable. Default ² = Ready Maximum: 250 V AC / 30 V DC, 2 A Minimum: 500 mW (12 V, 10 mA)
	20	RO1A		
	21	RO1B		
	22	RO2C		Relay output 2, programmable. Default ² = Running Maximum: 250 V AC / 30 V DC, 2 A Minimum: 500 mW (12 V, 10 mA)
	23	RO2A		
	24	RO2B		
	25	RO3C		Relay output 3, programmable. Default ² = Fault (-1) Maximum: 250 V AC / 30 V DC, 2 A Minimum: 500 mW (12 V, 10 mA)
	26	RO3A		
	27	RO3B		

¹ Digital input impedance 1.5 kohm. Maximum voltage for digital inputs is 30 V.

² Default values depend on the macro used. Values specified are for the default macro. See chapter [Application macros](#) on page 57.

Note: Terminals 3, 6 and 9 are at the same potential.

Note: For safety reasons the fault relay signals a “fault” when the ACQ550 is powered down.



WARNING! All ELV (Extra Low Voltage) circuits connected to the drive must be used within a zone of equipotential bonding, i.e. within a zone where all simultaneously accessible conductive parts are electrically connected to prevent hazardous voltages appearing between them. This is accomplished by a proper factory grounding.

The terminals on the control board as well as on the optional modules attachable to the board fulfil the Protective Extra Low Voltage (PELV) requirements stated in EN 50178, provided that the external circuits connected to the terminals also fulfil the requirements and the installation site is below 2000 m (6562 ft).

You can wire the digital input terminals in either a PNP or NPN configuration.

PNP connection (source)

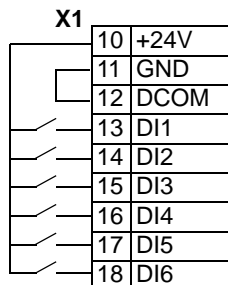

NPN connection (sink)

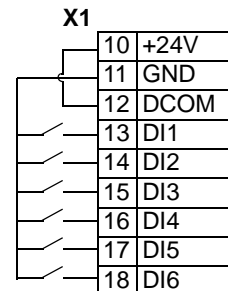

Install the wiring

Checking motor and motor cable insulation



WARNING! Check the motor and motor cable insulation before connecting the drive to input power. For this test, make sure that motor cables are NOT connected to the drive.

1. Complete motor cable connections to the motor, but NOT to the drive output terminals (U2, V2, W2).
2. Measure the insulation resistance between each phase conductor and the Protective Earth conductor using a measuring voltage of 500 V DC. The insulation resistance of an ABB motor must exceed 10 Mohm (reference value at 25 °C or 77 °F). For the insulation resistance of other motors, please consult the manufacturer's instructions. **Note:** Moisture inside the motor casing will reduce the insulation resistance. If moisture is suspected, dry the motor and repeat the measurement.



Wiring **IP21** / UL type 1 enclosure with **cables**

1. Open the appropriate knockouts in the conduit/gland box. (See section [Conduit/Gland kit](#) on page 19.)
2. Install the cable clamps for the power/motor cables.
3. On the input power cable, strip the sheathing back far enough to route individual wires.
4. On the motor cable, strip the sheathing back far enough to expose the copper wire shield so that the shield can be twisted into a bundle (pig-tail). Keep the bundle not longer than five times its width to minimize noise radiation.
360° grounding under the clamp is recommended for the motor cable to minimize noise radiation. In this case, remove the sheathing at the cable clamp.
5. Route both cables through the clamps.
6. Strip and connect the power/motor wires and the power ground wire to the drive terminals. See the table on the right for tightening torques.

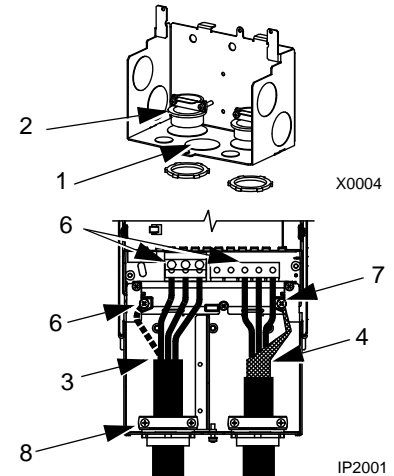

Frame size	Tightening torque	
	N·m	lb·ft
R1, R2	1.4	1
R3	2.5	1.8
R4	5.6; PE: 2	4; PE 1.5
R5	15	11
R6	40; PE: 8	30; PE: 6

Note: For R6 frame size, refer to section [Power terminal considerations – R6 frame size](#) on page 277.

7. Connect the bundle (pig-tail) created from the motor cable shield to the GND terminal.
8. Install conduit/gland box and tighten the cable clamps.
9. Install the cable clamp(s) for the control cable(s). (Power/motor cables and clamps not shown in the figure.)
10. Strip control cable sheathing and twist the copper shield into a bundle (pig-tail).
11. Route control cable(s) through clamp(s) and tighten clamp(s).
12. Connect the ground shield bundle (pig-tail) for digital and analog I/O cables at X1-1. (Ground only at the drive end.)
13. Strip and connect the individual control wires to the drive terminals. See section [Control terminals table](#) on page 24. Use a tightening torque of 0.4 N·m (0.3 lb·ft).
14. Install the conduit/gland box cover (1 screw).

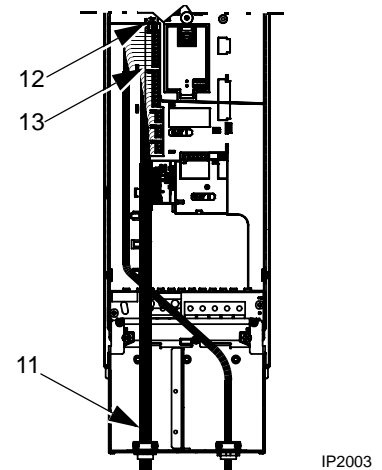
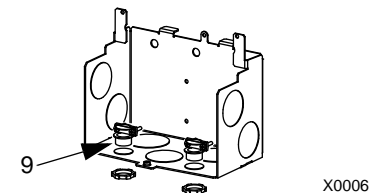
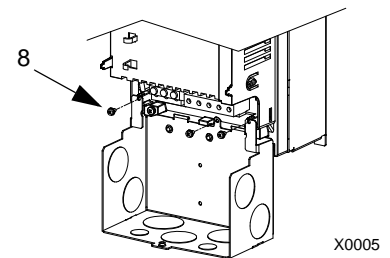

Wiring **IP21** / UL type 1 enclosure with **conduit**

1. Open the appropriate knockouts in the conduit/gland box. (See section [Conduit/Gland kit](#) on page 19.)
2. Install thin-wall conduit clamps (not supplied).
3. Install conduit/gland box.
4. Connect conduit runs to box.
5. Route input power and motor wiring through conduits (must be separate conduit runs).
6. Strip wires.
7. Connect power, motor and ground wires to the drive terminals. See the table on the right for tightening torques.

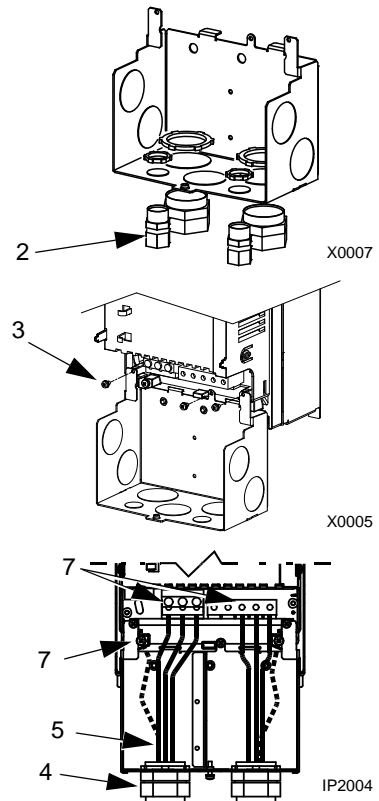

Note: For R6 frame size, refer to section [Power terminal considerations – R6 frame size](#) on page 277.

Frame size	Tightening torque	
	N·m	lb·ft
R1, R2	1.4	1
R3	2.5	1.8
R4	5.6; PE: 2	4; PE 1.5
R5	15	11
R6	40; PE: 8	30; PE: 6

8. Route the control cable through the conduit (must be separate from input power and motor conduit runs).
9. Strip the control cable sheathing and twist the copper shield into a bundle (pig-tail).
10. Connect the ground shield bundle (pig-tail) for digital and analog I/O cables at X1-1. (Ground only at the drive end.)
11. Strip and connect the individual control wires to the drive terminals. See section [Control terminals table](#) on page 24. Use a tightening torque of 0.4 N·m (0.3 lb·ft).
12. Install the conduit/gland box cover (1 screw).

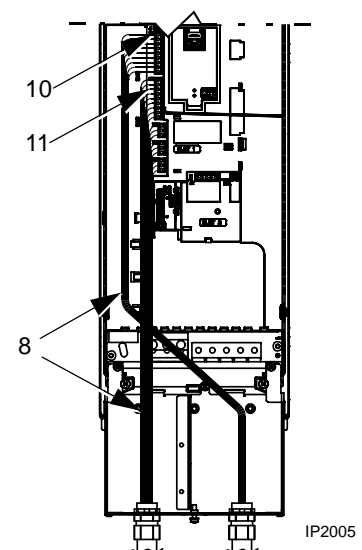

Wiring **IP54** / UL type 12 enclosure with **cables**

1. Cut the cable seals as needed for the power, motor and control cables. The cable seals are cone-shaped, rubber seals on the bottom of the drive. The conical part of the seals must face downwards when the seals are inserted in the lead-through plate holes.
2. On the input power cable, strip the sheathing back far enough to route individual wires.
3. On the motor cable, strip the sheathing back far enough to expose the copper wire shield so that the shield can be twisted into a bundle (pig-tail). Keep the bundle not longer than five times its width to minimize noise radiation. 360° grounding under the clamp is recommended for the motor cable to minimize noise radiation. In this case, remove the sheathing at the cable clamp.
4. Route both cables through the clamps and tighten the clamps.
5. Strip and connect the power/motor wires and the power ground wire to the drive terminals. See the table on the right for tightening torques.

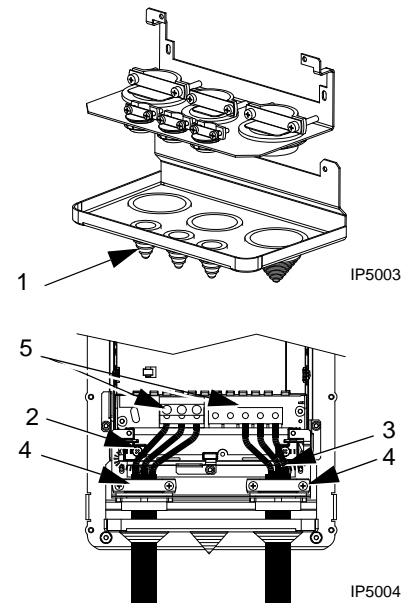

Frame size	Tightening torque	
	N·m	lb·ft
R1, R2	1.4	1
R3	2.5	1.8
R4	5.6; PE: 2	4; PE 1.5
R5	15	11
R6	40; PE: 8	30; PE: 6

Note: For R6 frame size, refer to section [Power terminal considerations – R6 frame size](#) on page [277](#).

6. Connect the bundle (pig-tail) created from the motor cable shield to the GND terminal.
7. Strip control cable sheathing and twist the copper shield into a bundle (pig-tail).
8. Route control cable(s) through clamp(s) and tighten clamp(s).
9. Connect the ground shield bundle (pig-tail) for digital and analog I/O cables at X1-1. (Ground only at the drive end.)
10. Strip and connect the individual control wires to the drive terminals. See section [Control terminals table](#) on page [24](#). Use a tightening torque of 0.4 N·m (0.3 lb·ft).

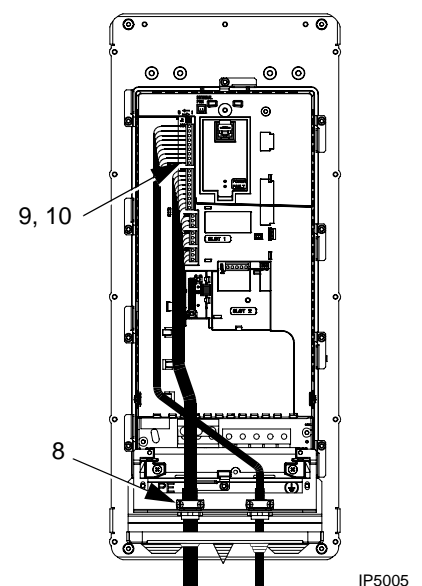

Wiring **IP54** / UL type 12 enclosure with **conduit**

1. Remove and discard the cable seals where conduit will be installed. (The cable seals are cone-shaped, rubber seals on the bottom of the drive.)
2. For each conduit run, install water tight conduit connectors (not supplied).
3. Route the power wiring through the conduit.
4. Route the motor wiring through the conduit.
5. Strip the wires.
6. Connect the power, motor and ground wires to the drive terminals. See the table on the right for tightening torques.

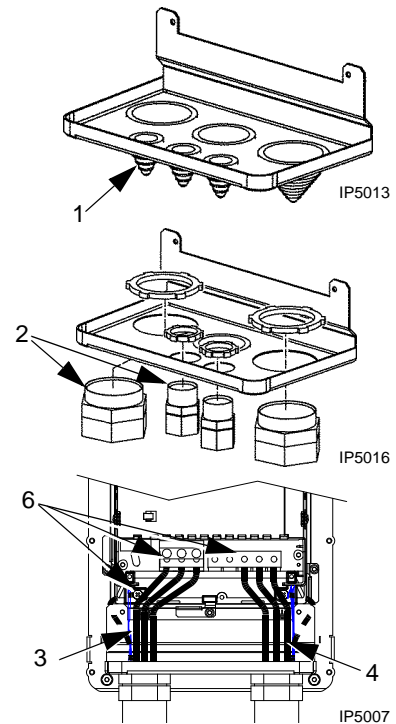

Note: For R6 frame size, refer to section [Power terminal considerations – R6 frame size](#) on page [277](#).

Frame size	Tightening torque	
	N·m	lb·ft
R1, R2	1.4	1
R3	2.5	1.8
R4	5.6; PE: 2	4; PE 1.5
R5	15	11
R6	40; PE: 8	30; PE: 6

7. Route the control cable through the conduit.
8. Strip the control cable sheathing and twist the copper shield into a bundle (pig-tail).
9. Connect the ground shield bundle (pig-tail) for digital and analog I/O cables at X1-1. (Ground only at the drive end.)
10. Strip and connect the individual control wires to the drive terminals. See section [Control terminals table](#) on page [24](#). Use a tightening torque of 0.4 N·m (0.3 lb·ft).

Check installation

Before applying power, perform the following checks.

✓	Check
	Installation environment conforms to the drive's specifications for ambient conditions.
	The drive is mounted securely.
	Space around the drive meets the drive's specifications for cooling.
	The motor and driven equipment are ready for start.
	For IT systems and corner grounded TN systems: The internal EMC filter is disconnected (see section Disconnecting the internal EMC filter on page 23).
	The drive is properly grounded.
	The input power (mains) voltage matches the drive nominal input voltage.
	The input power (mains) connections at U1, V1 and W1 are connected and tightened as specified.
	The input power (mains) fuses are installed.
	The motor connections at U2, V2 and W2 are connected and tightened as specified.
	The motor cable is routed away from other cables.
	NO power factor compensation capacitors are in the motor cable.
	The control connections are connected and tightened as specified.
	NO tools or foreign objects (such as drill shavings) are inside the drive.
	NO alternate power source for the motor (such as a bypass connection) is connected – no voltage is applied to the output of the drive.

Reinstall the cover

IP21 / UL type 1

1. Align the cover and slide it on.
2. Tighten the captive screw.
3. Reinstall the control panel.
4. Continue with start-up. See chapter [Start-up, control with I/O and ID Run](#) on page 33.

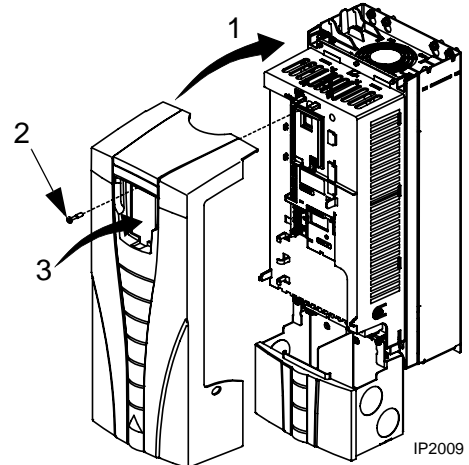

IP54 / UL type 12

1. Align the cover and slide it on.
2. Tighten the captive screws around the edge of the cover.
3. Slide the hood down over the top of the cover. (Only needed for UL type 12 installations.)
4. Install the two screws that attach the hood. (Only needed for UL type 12 installations.)
5. Install the control panel.

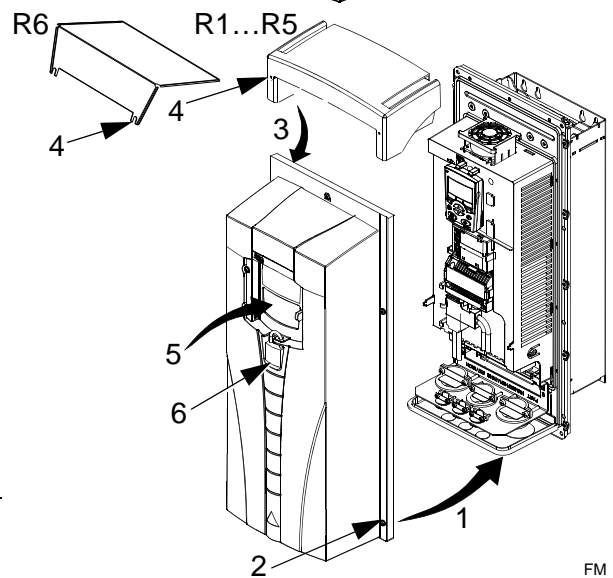

Note: The control panel window must be closed to comply with IP54 / UL type 12.

6. Optional: Add a lock (not supplied) to secure the control panel window.
7. Continue with start-up. See chapter [Start-up, control with I/O and ID Run](#) on page 33.

Start-up, control with I/O and ID Run

The chapter instructs how to:

- perform the start-up
- start, stop, change the direction of rotation and adjust the speed of the motor through the I/O interface
- perform an Identification Run for the drive.

Using the control panel to do these tasks is explained briefly in this chapter. For details on how to use the control panel, refer to chapter [Control panel](#) starting on page 43.

How to start up the drive

You can either run the Start-up Assistant (see section [How to perform the guided start-up](#) on page 33) or perform a limited start-up (see section [How to perform the limited start-up](#) on page 35).

The Start-up Assistant guides you through all essential settings to be done. In the limited start-up, the drive gives no guidance; you go through the very basic settings by following the instructions given in the manual.

How to perform the guided start-up

Before you start, ensure that you have the motor nameplate data on hand.

SAFETY





















The start-up may only be carried out by a qualified electrician.

The safety instructions given in chapter [Safety](#) must be followed during the start-up procedure.







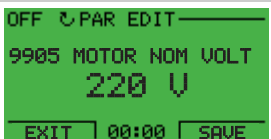
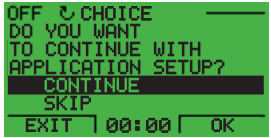









The drive will start up automatically at power up, if the external run command is on.

- Check the installation. See the checklist in chapter [Installation](#), page 31.
- Check that the starting of the motor does not cause any danger.
De-couple the driven machine if:
 - there is a risk of damage in case of incorrect direction of rotation, or
 - an ID Run needs to be performed during the drive start-up. ID Run is essential only in applications that require the ultimate in motor control accuracy.

POWER-UP	
<ul style="list-style-type: none"> <input type="checkbox"/> Apply input power. <input type="checkbox"/> Select MENU to enter the main menu. <input type="checkbox"/> Select ASSISTANTS with keys / and select ENTER. <input type="checkbox"/> Scroll to START-UP ASSISTANT with keys /. 	 
SELECTING THE LANGUAGE	
<ul style="list-style-type: none"> <input type="checkbox"/> The display then asks you to select the language. Scroll to the desired language with keys / and press  to accept. If you press , the Start-up Assistant is stopped. 	
STARTING THE GUIDED SET-UP	
<ul style="list-style-type: none"> <input type="checkbox"/> The Start-up Assistant now guides you through the set-up tasks, starting with the motor set-up. Set the motor data to exactly the same value as on the motor nameplate. Scroll to the desired parameter value with keys / and press  to accept and continue with the Start-up Assistant. Note: At any time, if you press , the Start-up Assistant is stopped and the display goes to the Output mode. <input type="checkbox"/> After completing a set-up task, the Start-up Assistant defaults to application macro PID control. <ul style="list-style-type: none"> • Press  (when Continue is highlighted) to continue with the suggested task. • Press key  to highlight Skip and then press  to move to the following task without doing the suggested task. • Press  to stop the Start-up Assistant. 	 
SAVING A USER PARAMETER SET AND FINAL CHECK	
<ul style="list-style-type: none"> <input type="checkbox"/> The start-up is now completed. However, it might be useful at this stage to set the parameters required by your application and save the settings as a user parameter set as instructed in section User parameter sets on page 66. <input type="checkbox"/> After the whole set-up is completed, check there are no faults or alarms shown on the display and the panel LED is green and does not blink. 	
The drive is now ready for use.	

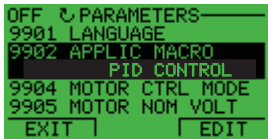
How to perform the limited start-up

Before you start, ensure that you have the motor nameplate data on hand.

SAFETY	
	<p>The start-up may only be carried out by a qualified electrician.</p> <p>The safety instructions given in chapter Safety must be followed during the start-up procedure.</p>
	<p>The drive will start up automatically at power up, if the external run command is on.</p>
<p><input type="checkbox"/> Check the installation. See the checklist in chapter Installation, page 31.</p> <p><input type="checkbox"/> Check that the starting of the motor does not cause any danger.</p> <p>De-couple the driven machine if:</p> <ul style="list-style-type: none"> • there is a risk of damage in case of incorrect direction of rotation, or • an ID Run can be performed during the drive start-up. ID Run is essential only in applications that require the ultimate in motor control accuracy. 	
POWER-UP	
<p><input type="checkbox"/> Apply input power.</p> <p><input type="checkbox"/> Select MENU to enter the main menu.</p> <p><input type="checkbox"/> Select the Parameters mode with keys / and select ENTER to select the Parameters mode.</p>	
<p><input type="checkbox"/> Select the Start-Up Data group with keys / and select SEL.</p>	
<p><input type="checkbox"/> Select the application macro (parameter 9902) with keys /. Select EDIT to change the parameter value. The default value 6 (PID CONTROL) is suitable in most cases for pumping.</p>	
<p><input type="checkbox"/> Press keys / to change the parameter value.</p>	
<p><input type="checkbox"/> Select SAVE to store the modified value or select CANCEL to leave the set mode. Any modifications not saved are cancelled.</p>	

- Select EXIT to return to the listing of parameter groups.
- Select the motor control mode (parameter 9904) with keys /. Select EDIT to change the parameter value. 1 or 2 (VECTOR:SPEED) is available. 3 (SCALAR:FREQ) is the default, recommended in most cases:
 - for multimotor drives when the number of the motors connected to the drive is variable
 - when the nominal current of the motor is less than 20% of the nominal current of the drive
 - when the drive is used for test purposes with no motor connected.
- Press keys / to change the parameter value.
- Select SAVE to store the modified value or select CANCEL to leave the set mode. Any modifications not saved are cancelled.
- Select EXIT to return to the listing of parameter groups.

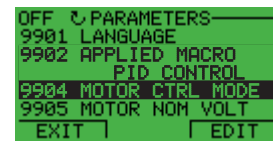

- Similarly, enter the motor data from the motor nameplate:

ABB Motors									
3 ~ motor M2AA 200 MLA 4									
EC 200 ML 55									
No									
Ins. cl. F P 55									
V	Hz	kW	r/min	A	cos φ	IA/IN	IE/IS		
690 Y	50	30	1475	32.5	0.83				
400 D	50	30	1475	56	0.83				
660 Y	50	30	1470	34	0.83				
380 D	50	30	1470	59	0.83				
415 D	50	30	1475	54	0.83				
440 D	60	35	1770	59	0.83				
Cat no 3GAA 202 001 - ADA									
6312/C3		6210/C3		180 kg					
EC 34-1									

380 V supply voltage

- Motor nominal voltage (parameter 9905)

Note: Set the motor data to exactly the same value as on the motor nameplate. For example, if the motor nominal speed is 1470 rpm on the nameplate, setting the value of parameter 9908 MOTOR NOM SPEED to 1500 rpm results in the wrong operation of the drive.

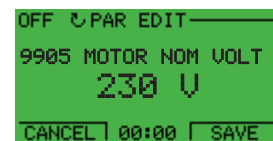

- Motor nominal current (parameter [9906](#))

Allowed range: $0.2 \dots 2.0 \cdot I_{2hd}$ A

- Motor nominal frequency (parameter [9907](#))

- Motor nominal speed (parameter [9908](#))

- Motor nominal power (parameter [9909](#))

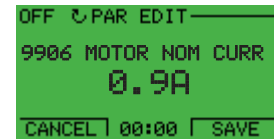

OFF ↵ PAR EDIT
9906 MOTOR NOM CURR
0.9A
CANCEL 00:00 SAVE

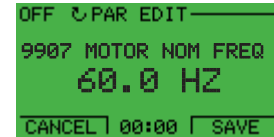

OFF ↵ PAR EDIT
9907 MOTOR NOM FREQ
60.0 HZ
CANCEL 00:00 SAVE

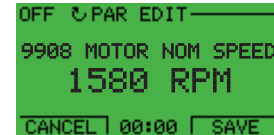

OFF ↵ PAR EDIT
9908 MOTOR NOM SPEED
1580 RPM
CANCEL 00:00 SAVE

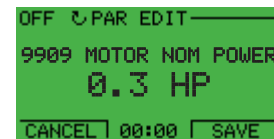

OFF ↵ PAR EDIT
9909 MOTOR NOM POWER
0.3 HP
CANCEL 00:00 SAVE

- Select the motor identification method (parameter [9910](#)).

The default value 0 (OFF/IDMAGN) using the identification magnetization is suitable for most applications. It is applied in this basic start-up procedure. Note however that this requires that:

- parameter [9904](#) is set to 1 or 2 (VECTOR:SPEED), or
- parameter [9904](#) is set to 3 (SCALAR:FREQ) and parameter [2101](#) is set to 3 (SCALAR FLYST) or 5 (FLY + BOOST).



If your selection is 0 (OFF/IDMAGN), move to the next step.

Value 1 (ON), which performs a separate ID Run, should be selected if:

- vector control mode is used [parameter [9904](#) = 1 or 2 (VECTOR:SPEED)],
- the operation point is near zero speed, and/or
- operation at torque range above the motor nominal torque over a wide speed range and without any measured speed feedback is required.

If you decide to do the ID Run [value 1 (ON)], continue by following the separate instructions given on page [40](#) in section [How to perform the ID Run](#) and then return to step [DIRECTION OF THE MOTOR ROTATION](#) on page [38](#).

DIRECTION OF THE MOTOR ROTATION

- Check the direction of the motor rotation.
- If the drive is in AUTO control, switch to OFF control by pressing .
 - Go to parameter 1003 – to check direction of motor. Default is 1 (FORWARD).
 - Press  to start the motor.
 - Check that the actual direction of the motor is the same as indicated on the display (FWD means forward and REV reverse).
 - Press  to stop the motor.
- To change the direction of the motor rotation:
- Disconnect input power from the drive, and wait 5 minutes for the intermediate circuit capacitors to discharge. Measure the voltage between each input terminal (U1, V1 and W1) and earth with a multimeter to ensure that the drive is discharged.
 - Exchange the position of two motor cable phase conductors at the drive output terminals or at the motor connection box.
 - Verify your work by applying input power and repeating the check as described above.

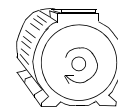

forward
direction

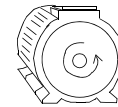

reverse
direction

SPEED LIMITS AND ACCELERATION/DECELERATION TIMES

- Set the minimum speed (parameter [2001](#)).
- Set the maximum speed (parameter [2002](#)).
- Set the acceleration time 1 (parameter [2202](#)).
- Note:** Check also acceleration time 2 (parameter [2205](#)) if two acceleration times will be used in the application.
- Set the deceleration time 1 (parameter [2203](#)).
- Note:** Set also deceleration time 2 (parameter [2206](#)) if two deceleration times will be used in the application.

SAVING A USER PARAMETER SET AND FINAL CHECK

- The start-up is now completed. However, it might be useful at this stage to set the parameters required by your application and save the settings as a user parameter set as instructed in section [User parameter sets](#) on page [66](#).
- Check that the drive state is OK.
Check that there are no faults or alarms shown on the display and that the panel LED is green and does not blink.

The drive is now ready for use.

How to control the drive through the I/O interface

The table below instructs how to operate the drive through the digital and analog inputs when:

- the motor start-up is performed, and
- the default (standard) parameter settings are valid.

PRELIMINARY SETTINGS	
<p>If you need to change the direction of rotation, check that parameter 1003 is set to 3 (REQUEST).</p> <p>Ensure that the control connections are wired according to the connection diagram given for the ABB Standard macro.</p> <p>Ensure that the drive is in remote control.</p>	<p>See section ABB 2-wire macro on page 58.</p> <p>In remote control, the panel display shows text AUTO.</p>
STARTING AND CONTROLLING THE SPEED OF THE MOTOR	
<p>Start by switching digital input DI1 on. ACQ Control Panel: The arrow starts rotating. It is dotted until the setpoint is reached.</p> <p>Regulate the drive output frequency (motor speed) by adjusting the voltage of analog input AI1.</p>	
CHANGING THE DIRECTION OF ROTATION OF THE MOTOR	
<p>Reverse direction: Switch digital input DI2 on.</p> <p>Forward direction: Switch digital input DI2 off.</p>	
STOPPING THE MOTOR	
<p>Switch digital input DI1 off. The motor stops. ACQ Control Panel: The arrow stops rotating.</p>	

How to perform the ID Run

The drive estimates motor characteristics automatically using identification magnetization when the drive is started for the first time and after any motor parameter (*Group 99: START-UP DATA*) is changed. This is valid when parameter **9910** ID RUN has value 0 (OFF/IDMAGN), and

- parameter **9904** = 1 or 2 (VECTOR:SPEED), or
- parameter **9904** = 3 (SCALAR:FREQ) and parameter **2101** = 3 (SCALAR FLYST) or 5 (FLY + BOOST).

In most applications there is no need to perform a separate ID Run [**9910** ID RUN = 1 (ON)]. The ID Run should be selected if:

- vector control mode is used [parameter **9904** = 1 or 2 (VECTOR:SPEED), and/or
- the operation point is near zero speed, and/or
- operation at torque range above the motor nominal torque over a wide speed range and without any measured speed feedback is required.

Note: If motor parameters (*Group 99: START-UP DATA*) are changed after the ID Run, it must be repeated.

ID Run procedure





The general parameter setting procedure is not repeated here. For ACQ Control Panel see page [47](#) in chapter *Control panel*.

PRE-CHECK

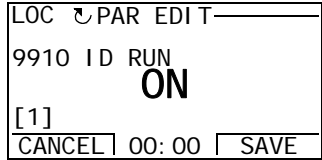

WARNING! The motor will run at up to approximately 50...80% of the nominal speed during the ID Run. The motor will rotate in the forward direction. **Ensure that it is safe to run the motor before performing the ID Run!**

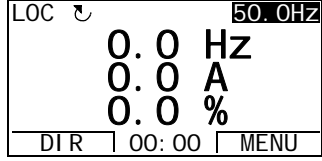
- De-couple the motor from the driven equipment.
- Check that the values of the motor data parameters **9905...9909** are equivalent to those on the motor nameplate, as shown in the steps on page [36](#).
- If parameter values (*Group 01: OPERATING DATA* to *Group 98: OPTIONS*) are changed before the ID Run, check that the new settings meet the following conditions:
 - 2001** MINIMUM SPEED ≤ 0 rpm
 - 2002** MAXIMUM SPEED $> 80\%$ of the motor rated speed
 - 2003** MAXIMUM CURRENT $\geq I_{2hd}$
 - 2017** MAX TORQUE 1 $> 50\%$ or **2018** MAX TORQUE 2 $> 50\%$, depending on which limit is in use according to parameter **2014** MAX TORQUE SEL.
- Check that the Run Enable signal is on (parameter **1601**).
- Ensure that the panel is in local control. Press key  to switch between HAND and AUTO modes.

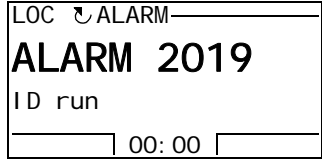
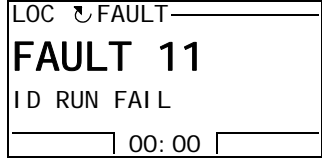
ID RUN WITH THE ACQ CONTROL PANEL	
<input type="checkbox"/> Change parameter 9910 ID RUN to 1 (ON). Save the new setting by pressing  .	
<input type="checkbox"/> If you want to monitor actual values during the ID Run, go to the Output mode by pressing  repeatedly until you get there.	
<input type="checkbox"/> Press  to start the ID Run. The panel keeps switching between the display that was shown when you started the ID Run and the alarm display presented on the right. In general, it is recommended not to press any control panel keys during the ID Run. However, you can stop the ID Run at any time by pressing  . After the ID Run is completed, the alarm display is not shown any more. If the ID Run fails, the fault display presented on the right is shown.	 

Control panel

W/WW control panel features

The ACQ550 W/WW control panel (ACQ-CP-AQ) features:

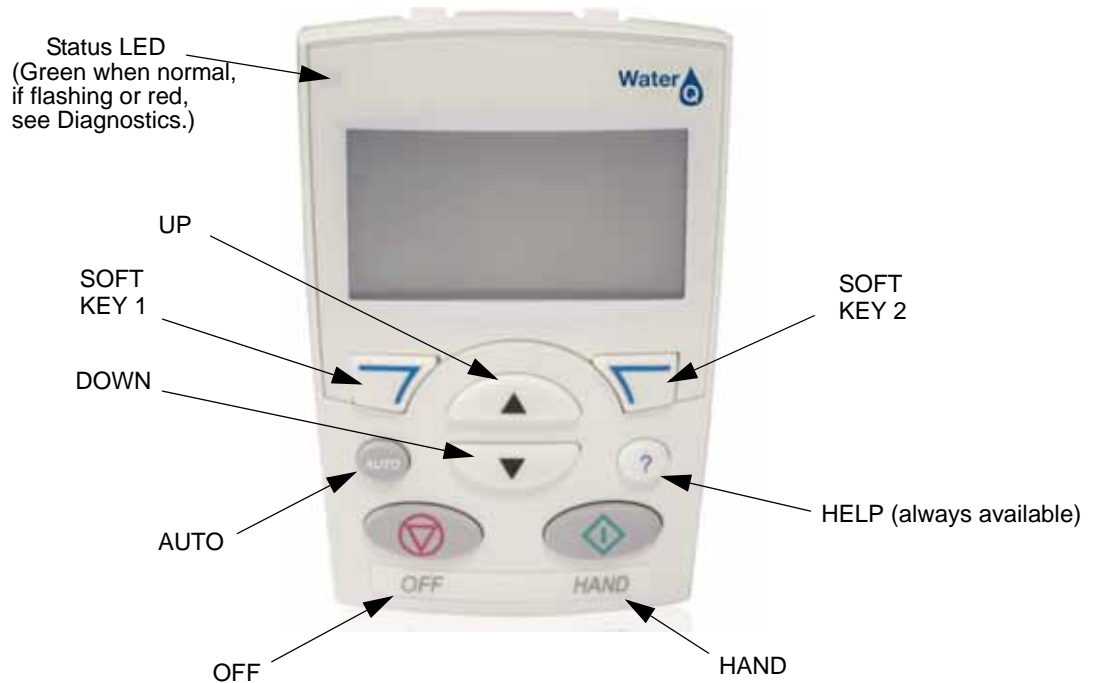

X0201



- Language selection for the display
- Drive connection that can be made or detached at any time
- Start-up assistant to facilitate drive commissioning
- Copy function for moving parameters to other ACQ550 drives
- Backup function for saving parameter sets
- Context sensitive help
- Real-time clock

General display features

Soft key functions

The soft key functions are defined by text displayed just above each key.

Display contrast

To adjust display contrast, simultaneously press  and  or , as appropriate.

W/WW control panel modes

The W/WW control panel has several different modes for configuring, operating and diagnosing the drive. The modes are:

- **Standard Display Mode** – Shows drive status information and operates the drive.
- **Parameters Mode** – Edits parameter values individually.
- **Start-up Assistant Mode** – Guides the start-up and configuration.
- **Changed Parameters Mode** – Shows changed parameters.
- **Fault History Mode** – Shows the drive fault history.
- **Drive Parameter Backup Mode** – Stores or uploads the parameters.
- **Time & Date Mode** – Sets the time and date for the drive.
- **I/O Settings Mode** – Checks and edits the I/O settings.

Standard Display Mode

Use the Standard Display Mode to read information on the drive's status and to operate the drive. To reach the Standard Display Mode, press EXIT until the LCD display shows status information as described below.

Status information

Top. The top line of the LCD display shows the basic status information of the drive.

- **HAND** – Indicates that the drive control is local, that is, from the control panel.
- **AUTO** – Indicates that the drive control is remote, such as the basic I/O (X1) or fieldbus.
-  – Indicates the drive and motor rotation status as follows:

Control panel display	Significance
Rotating arrow (clockwise or counterclockwise)	<ul style="list-style-type: none"> • Drive is running and at setpoint • Shaft direction is forward or reverse
Rotating dotted arrow blinking	Drive is running but not at setpoint
Stationary dotted arrow	Start command is present, but motor is not running. E.g. start enable is missing.

- **Upper right** – shows the active reference.

Middle. Using parameter group 34, the middle of the LCD display can be configured to display:

- **One to three parameter values** – The default display shows parameters 0102 (OUTPUT SPEED), 0104 (CURRENT) in amperes and 0105 (TORQUE) in percentage.
 - Use parameters 3401, 3408, and 3415 to select the parameters (from Group 01) to display. Entering “parameter” 0100 results in no parameter displayed. For example, if 3401 = 0100 and 3415 = 0100, then only the parameter specified by 3408 appears in the Control Panel display.
 - You can also scale each parameter in the display, for example, to convert the

motor speed to a display of conveyor speed. Parameters 3402...3405 scale the parameter specified by 3401, parameters 3409...3412 scale the parameter specified by 3408, etc.

- A bar meter rather than one of the parameter values.
 - Enable bar graph displays using parameters 3404, 3411 and 3418.

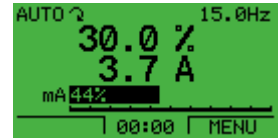

Bottom. The bottom of the LCD display shows:

- Lower corners – show the functions currently assigned to the two soft keys.
- Lower middle – displays the current time (if configured to show the time).

Operating the drive

AUTO/HAND – The very first time the drive is powered up, it is in the auto control (AUTO) mode, and is controlled from the Control terminal block X1.

To switch to hand control (HAND) and control the drive using the control panel, press and hold the or button.

- Pressing the HAND button switches the drive to hand control while keeping the drive running.
- Pressing the OFF button switches to hand control and stops the drive.

To switch back to auto control (AUTO), press and hold the button.

Hand/Auto/Off – To start the drive press the HAND or AUTO buttons, to stop the drive press the OFF button.

Reference – To modify the reference (only possible if the display in the upper right corner is in reverse video) press the UP or DOWN buttons (the reference changes immediately).













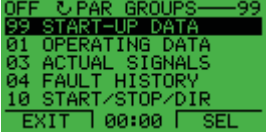

The reference can be modified in the local control mode (HAND/OFF), and can be parameterized (using Group 11 reference select) to also allow modification in the remote control mode.

Note: The Start/Stop, Shaft direction and Reference functions are only valid in local control (HAND/OFF) mode.

Parameters Mode

To change the parameters, follow these steps:

1	Select MENU to enter the main menu.		
2	Select the Parameters mode with the UP/DOWN buttons, and select ENTER to select the Parameters Mode.	 	

3	Select the appropriate parameter group with the UP/DOWN buttons and select SEL.	  	 <pre> OFF P.PAR GROUPS—99 99 START-UP DATA 01 OPERATING DATA 03 ACTUAL SIGNALS 04 FAULT HISTORY 10 START/STOP/DIR EXIT 00:00 SEL </pre>
4	Select the appropriate parameter in a group with the UP/DOWN buttons. Select EDIT to change the parameter.	  	 <pre> OFF P.PARAMETERS— 9901 LANGUAGE 9902 APPLIC MACRO PID CONTROL 9904 MOTOR CTRL MODE 9905 MOTOR NOM VOLT EXIT EDIT </pre>
5	Press the UP/DOWN buttons to change the parameter value.	 	 <pre> OFF P.PAR EDIT— 9902 APPLIC MACRO PID CONTROL [6] CANCEL 00:00 SAVE </pre>
6	Select SAVE to store the modified value or select CANCEL to leave the set mode. <ul style="list-style-type: none"> Any modifications not saved are cancelled. Each individual parameter setting is valid immediately after pressing SAVE. 		 <pre> OFF P.PAR EDIT— 9902 APPLIC MACRO HAND/AUTO [5] CANCEL SAVE </pre>
7	Select EXIT to return to the listing of parameter groups, and again to return to the main menu.	 	 <pre> OFF P.PARAMETERS— 9901 LANGUAGE 9902 APPLIC MACRO PID CONTROL 9904 MOTOR CTRL MODE 9905 MOTOR NOM VOLT EXIT EDIT </pre>

For detailed hardware description, see the [Technical data](#) section on page 267.

Note: The current parameter value appears below the highlighted parameter.













Note: To view the default parameter value, press the UP/DOWN buttons simultaneously.

Note: The most typical and necessary parameters to change are parameter groups 99 Start-up data, 10 Start/Stop/Dir, 11 Reference Select, 20 Limits, 21 Start/Stop, 22 Accel/Decel, 26 Motor Control and 30 Fault Functions.

Note: To restore the default factory settings, select the application macro PID CONTROL Default.

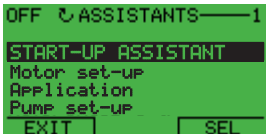
Start-Up Assistant Mode

To start the Start-Up Assistant, follow these steps:

1	Select MENU to enter the main menu		
2	Select ASSISTANTS with the UP/DOWN buttons and select ENTER.	  	
3	Scroll to START-UP ASSISTANT with the UP/DOWN buttons and select SEL. Select to answer Do you want to use the START-UP ASSISTANT? YES or NO	  	
4	Change the values suggested by the assistant to your preferences and then press SAVE after every change.	  	

The Start-up Assistant will guide you through the start-up.

The Start-up Assistant guides you through the basic programming of a new drive. (You should familiarize yourself with the control panel operation and follow the steps outlined above.) At the first start, the drive automatically suggests entering the first task, Language Select. The assistant also checks the values entered to prevent entries that are out of range.

The Start-up Assistant is divided into tasks. You may activate the tasks one after the other, as the Start-up Assistant suggests, or independently.

Note: If you want to set the parameters independently, use the Parameters Mode.





The table below lists the tasks of the assistants and the relevant drive parameters. Depending on the selection made in the Application task (parameter [9902](#) APPLIC MACRO), the Start-up Assistant decides which consequent tasks it suggests.

Name	Description
Language select	Selecting the language
Motor set-up	Setting the motor data Performing the motor identification. (If the speed limits are not in the allowed range: Setting the limits.)
Application	Selecting the application macro
PID control	Selecting the source for the process reference (If AI1 is used: Setting analog input AI1 limits, scale, inversion) Setting the reference limits Setting the speed (reference) limits Setting the source and limits for the process actual value

Name	Description (Continued)
Speed control EXT1	Selecting the source for the speed reference (If AI1 is used: Setting analog input AI1 limits, scale, inversion) Setting the reference limits Setting the speed (frequency) limits Setting the acceleration and deceleration times
Speed control EXT2	Selecting the source for the speed reference (If AI1 is used: Setting analog input AI1 limits, scale, inversion) Setting the reference limits
Start/Stop control	Selecting the source for start and stop signals of the two external control locations, EXT1 and EXT2 Selecting between EXT1 and EXT2 Defining the direction control Defining the start and stop modes Selecting the use of Run Enable signal
Timed functions	Setting the timed functions Selecting the timed start/stop control for external control locations EXT1 and EXT2 Selecting timed EXT1/EXT2 control Activation of timed constant speed 1 Selecting timed function status indicated through relay output RO Selecting timed PID1 parameter set 1/2 control
Protections	Setting the current and torque limits
Output signals	Selecting the signals indicated through relay output RO Selecting the signals indicated through analog output AO Setting the minimum, maximum, scaling and inversion

Changed Parameters Mode

To view (and edit) a listing of all parameters that have been changed from macro default values, follow these steps:

1	Select MENU to enter the menu.		
2	Select CHANGED PAR with the UP/DOWN buttons and select ENTER.		
3	A list of changed parameters is displayed. Select EXIT to exit the Changed Parameters Mode.		

Fault History Mode

Use the Fault History Mode to see drive fault history, fault state details and help for the faults.

1. Select FAULT HISTORY in the Main Menu.
2. Press ENTER to see the latest faults (up to 10 faults, maximum).
3. Press DETAIL to see details for the selected fault.
 - Details are available for the three latest faults.
4. Press DIAG to see the help description for the fault. See [Diagnostics](#) section.

Note: If a power off occurs, only the three latest faults will remain (with details only in the first fault).

Drive Parameter Backup Mode











Use the Drive Parameter Backup Mode to export parameters from one drive to another. The parameters are uploaded from a drive to the control panel and downloaded from the control panel to another drive. Two options are available:

Par Backup Mode

The ACQ Control Panel can store a full set of drive parameters.

The Par Backup Mode has these functions:

- **Upload to Panel** – Copies all parameters from the drive to the Control Panel. This includes user sets of parameters (if defined) and internal parameters such as those created by the Motor Id Run. The Control Panel memory is non-volatile and does not depend on the panel's battery. To upload parameters to control panel, follow these steps:



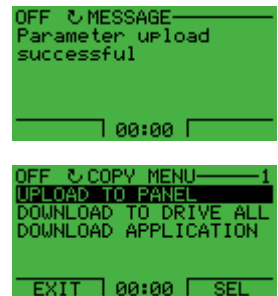



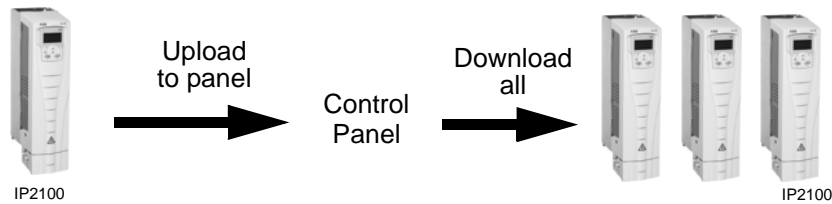

1	Select MENU to enter the main menu.		
2	Select PAR BACKUP with the UP/DOWN buttons and select ENTER.	  	
3	Scroll to Upload to Panel and select SEL.	  	
4	The text "Copying parameters" and a progress diagram is displayed. Select ABORT if you want to stop the process.		

<p>5</p>	<p>The text "Parameter upload successful" is displayed and the control panel returns to the PAR BACKUP menu. Select EXIT to return to the main menu. Now you can disconnect the panel.</p>		
----------	--	--	---

- Download Full Set** – Restores the full parameter set from the Control Panel to the drive. Use this option to restore a drive, or to configure identical drives. This download does not include user sets of parameters.

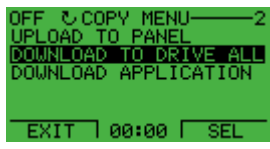

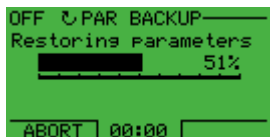
To download all parameters to drive, follow these steps:

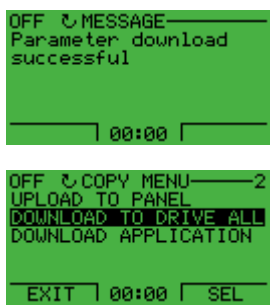
<p>1</p>	<p>Select MENU to enter the menu.</p>		
<p>2</p>	<p>Select PAR BACKUP with the UP/DOWN buttons.</p>		
<p>3</p>	<p>Scroll to Download to drive all and select SEL.</p>		
<p>4</p>	<p>The text "Restoring parameters" is displayed. Select ABORT if you want to stop the process.</p>		
<p>5</p>	<p>After the download stops, the message "Parameter download successful" is displayed and the control panel goes back to PAR BACKUP menu. Select EXIT to return to the main menu.</p>		

Note: Download Full Set writes all parameters to the drive, including motor parameters. Only use this function to restore a drive, or to transfer parameters to systems that are identical to the original system.

- **Download Application** – Copies a partial parameter set from the Control Panel to a drive. The partial set does not include internal motor parameters, parameters 9905...9909, 1605, 1607, 5201, nor any Group 51 and 53 parameters. Use this option to transfer parameters to systems that use similar configurations – the drive and motor sizes do not need to be the same.

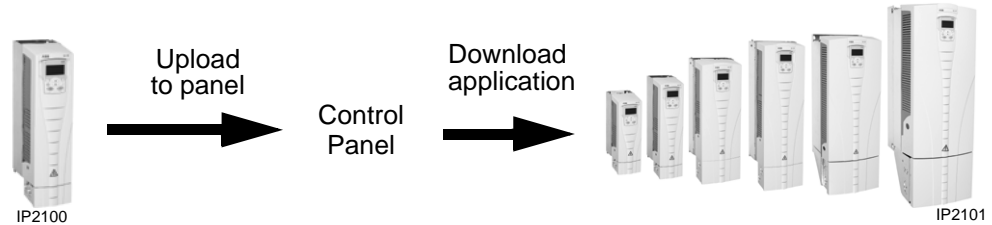

To download application to drive, follow these steps:

1	Select MENU to enter the menu.		
2	Select PAR BACKUP with the UP/DOWN buttons.		
3	Scroll to DOWNLOAD APPLICATION and select SEL.		
4	The text "Downloading parameters (partial)" is displayed. Select ABORT if you want to stop the process.		
5	The text "Parameter download successful" is displayed and the control panel returns to PAR BACKUP menu. Select EXIT to return to the main menu.		

- **Download User Set 1** - Copies USER S1 parameters (user sets are saved using parameter 9902 APPLIC MACRO) from the Control Panel to the drive.
- **Download User Set 2** - Copies USER S2 parameters from the Control Panel to the drive.

Handling inexact downloads

In some situations, an exact copy of the download is not appropriate for the target drive. Some examples:

- A download to an old drive specifies parameters/values that are not available on the old drive.
- A download (from an old drive) to a new drive does not have definitions for the new parameters – parameters that did not originally exist.
- A download can include an illegal value for the target drive, e.g. a backup from a small drive can have a switching frequency of 12 kHz whereas a big drive can only handle 8k Hz.

As a default, the control panel handles these situations by:

- Discarding parameters/values not available on the target drive.
- Using parameter default values when the download provides no values or invalid values.
- Providing a Differences List – A listing of the type and number of items that the target cannot accept exactly as specified.

LOC  DIFFERENCES ----	
VALUES UNDER MIN	3
VALUES OVER MAX	2
INVALID VALUES	1
EXTRA PARS	5
MISSING VALUES	7
READY	SEL

You can either accept the default edits by pressing READY, or view and edit each item as follows:

1. Highlight an item type in the Differences List (left screen below) and press SEL to see the details for the selected type (right screen below).

LOC  DIFFERENCES ----	
VALUES UNDER MIN	3
VALUES OVER MAX	2
INVALID VALUES	1
EXTRA PARS	5
MISSING VALUES	7
READY	SEL

→

LOC  INVALID VAL	
9902 APLIC MACRO	
2606*SWITCHING FREQ	
12 kHz	
8 kHz	
3401*DISP 1 SEL	
EXIT	EDIT

In the above-right “details” screen:

- The first item that requires editing is automatically highlighted and includes details: In general, the first item listed in the details is the value defined by the backup file. The second item listed is the “default edit.”
 - For tracking purposes, an asterisk initially appears by each item. As edits are made, the asterisks disappear.
2. In the illustrated example, the backup specifies a switching frequency of 12 kHz, but the target drive is limited to 8 kHz.
 3. Press EDIT to edit the parameter. The display is the target drive’s standard edit screen for the selected parameter.
 4. Highlight the desired value for the target drive.
 5. Press SAVE to save setting.

6. Press EXIT to step back to the differences view and continue for each remaining exception.
7. When your editing is complete, press READY in the Differences List and then select "Yes, save parameters."

Download failures

In some situations, the drive may be unable to accept a download. In those cases, the control panel display is: "Parameter download failed" plus one of the following causes:











- Set not found – You are attempting to download a data set that was not defined in the backup. The remedy is to manually define the set, or upload the set from a drive that has the desired set definitions.
- Par lock – The remedy is to unlock the parameter set (parameter 1602).
- Incompat drive/model – The remedy is to perform backups only between drives of the same type (ACQ/Water, ACS/industrial or ACH/HVAC).
- Too many differences – The remedy is to manually define a new set, or upload the set from a drive that more closely resembles the target drive.









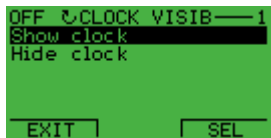





















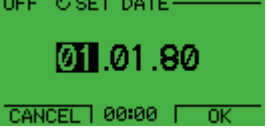

Note: If upload or download of parameters is aborted, the partial parameter set is not implemented.

TIME & DATE Set Mode

The TIME & DATE Set Mode is used for setting the time and date for the internal clock of the ACQ550. In order to use the timer functions of the ACQ550, the internal clock has to be set first. Date is used to determine weekdays and is visible in Fault logs.





















To set the clock, follow these steps:

1	Select MENU to enter the main menu.		
2	Scroll to Time & Date with the UP/DOWN buttons and select ENTER to enter the TIME & DATE Set Mode.	  	
3	Scroll to Clock Visibility with the UP/DOWN buttons and select SEL to change the visibility of the clock.	  	
4	Scroll to Show Clock with the UP/DOWN buttons and select SEL to make the clock visible.	  	

5	Scroll to Set Time with the UP/DOWN buttons and select SEL.	  	
6	Change the hours and minutes with the UP/DOWN buttons and select OK to save the values. The active value is displayed in inverted color.	  	
7	Scroll to Time Format with the UP/DOWN buttons and select SEL.	  	
8	The different formats are displayed. Select a format with the UP/DOWN buttons and select SEL to confirm the selection.	  	
9	Scroll to Set Date with the UP/DOWN buttons and select SEL.	  	
10	Change the days, months and year with the UP/DOWN buttons and select OK to save the values. The active value is displayed in inverted color.	  	
11	Scroll to Date Format with the UP/DOWN buttons and select SEL.	  	
12	The Date formats are displayed. Select a date format with the UP/DOWN buttons and select OK to confirm the selection.	  	
13	Select EXIT twice to return to the main menu.		

I/O Settings Mode

To view and edit the I/O settings, follow these steps:

1	Select MENU to enter the main menu.		
2	Scroll to I/O Settings with the UP/DOWN buttons and select ENTER.	  	
3	Scroll to the I/O setting you want to view with the UP/DOWN buttons and select SEL.	  	
4	Select the setting you want to view with the UP/DOWN buttons and select OK.	  	
5	You can change the value with the UP/DOWN buttons and save it by selecting SAVE. If you do not want to change the setting, select CANCEL.	   	
6	Select EXIT to return to the main menu.		

Application macros

Macros change a group of parameters to new, predefined values. Use macros to minimize the need for manual editing of parameters. Selecting a macro sets all other parameters to their default values, except:

- [Group 99: START-UP DATA](#) parameters (except parameter [9904](#))
- [1602](#) PARAMETER LOCK
- [1607](#) PARAM SAVE
- [3018](#) COMM FAULT FUNC and [3019](#) COMM FAULT TIME
- [9802](#) COMM PROT SEL
- [Group 53: EFB PROTOCOL](#) parameters
- [Group 29: MAINTENANCE TRIG](#) parameters.

After selecting a macro, you can make additional parameter changes manually with the control panel.

You enable application macros by setting the value for parameter [9902](#) APPLIC MACRO. By default, 6, PID CONTROL, is the enabled macro.

The following sections describe each of the application macros and provide a connection example for each macro.

The last section in this chapter, [Macro default values for parameters](#), lists the parameters that the macros change and the default values established by each macro.

ABB 2-wire macro

This is the default macro. It provides a general purpose, 2-wire I/O configuration, with three (3) constant speeds. Parameter values are the default values defined in section [Complete parameter list](#) on page 69.

Connection example:

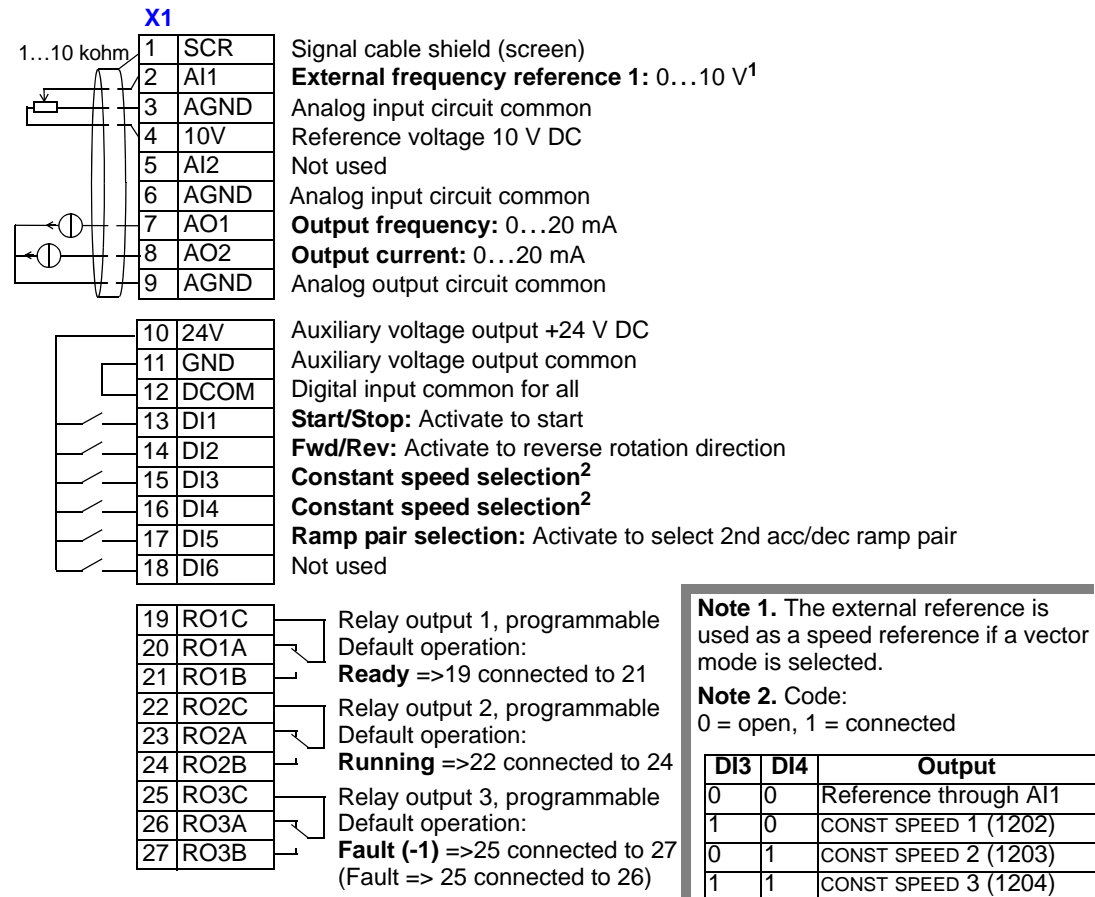

- Input signals**
- Analog reference (AI1)
 - Start, stop and direction (DI1,2)
 - Constant speed selection (DI3,4)
 - Ramp pair (1 of 2) selection (DI5)

- Output signals**
- Analog output AO1: Frequency
 - Analog output AO2: Current
 - Relay output 1: Ready
 - Relay output 2: Running
 - Relay output 3: Fault (-1)

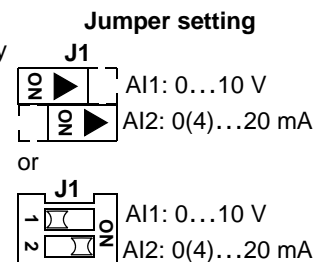

3-wire macro

This macro is used when the drive is controlled using momentary push-buttons. It provides three (3) constant speeds. To enable, set the value of parameter 9902 to 2 (3-WIRE).

Note: When the stop input (DI2) is deactivated (no input), the control panel start/stop buttons are disabled.

Connection example:

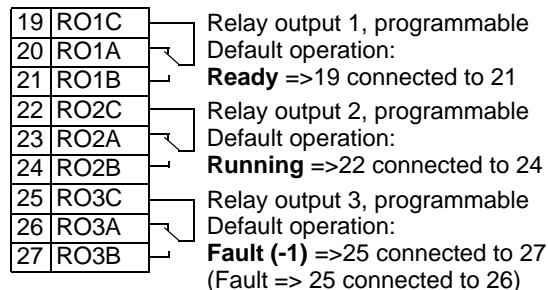
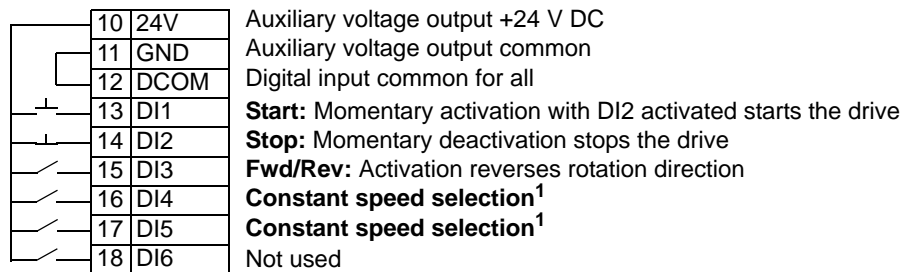
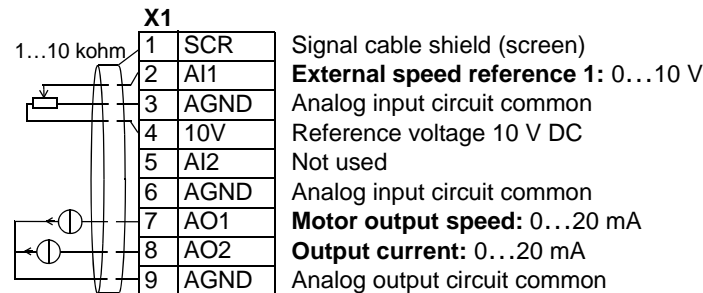

Note 1. Code:
0 = open, 1 = connected

DI4	DI5	Output
0	0	Reference through AI1
1	0	CONST SPEED 1 (1202)
0	1	CONST SPEED 2 (1203)
1	1	CONST SPEED 3 (1204)

Input signals

- Analog reference (AI1)
- Start, stop and direction (DI1,2,3)
- Constant speed selection (DI4,5)

Output signals

- Analog output AO1: Speed
- Analog output AO2: Current
- Relay output 1: Ready
- Relay output 2: Running
- Relay output 3: Fault (-1)

Jumper setting

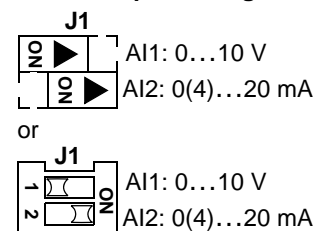

Alternate macro

This macro provides an I/O configuration adopted to a sequence of DI control signals used when alternating the rotation direction of the motor. To enable, set the value of parameter 9902 to 3 (ALTERNATE).

Connection example:

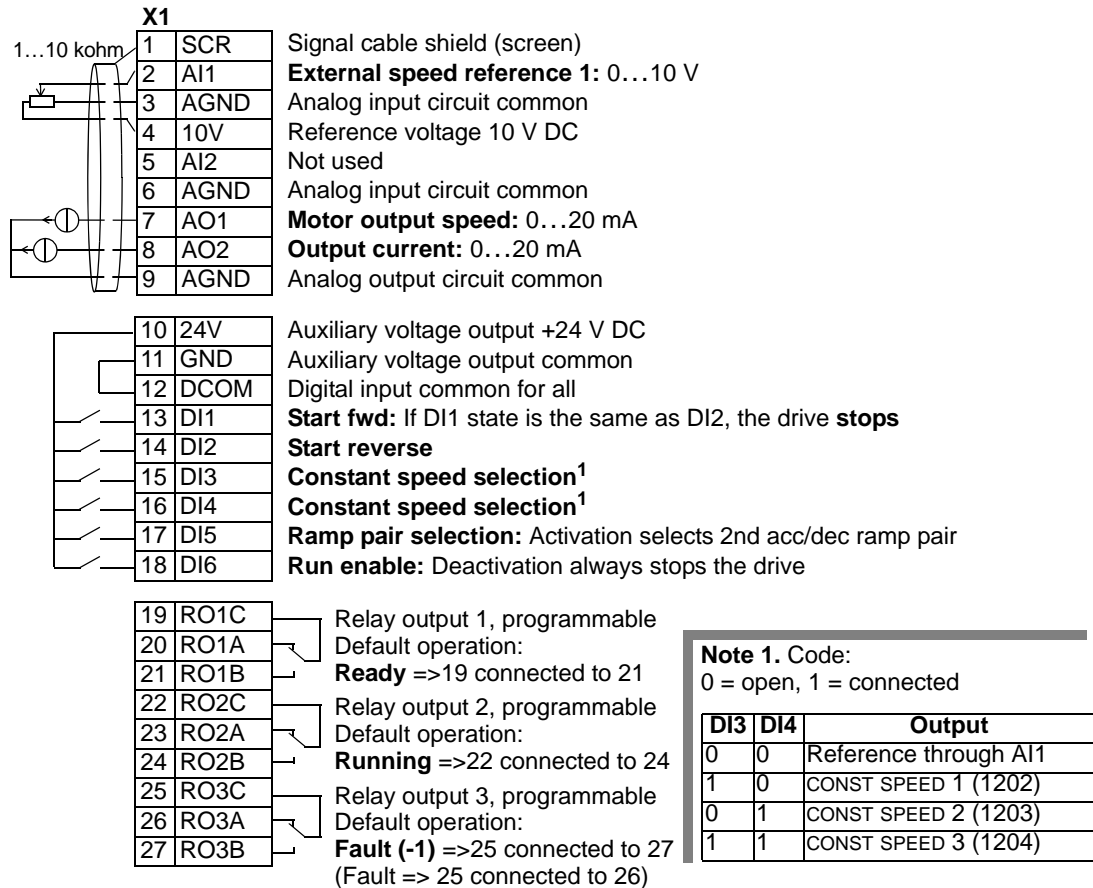

Input signals

- Analog reference (AI1)
- Start, stop and direction (DI1,2)
- Constant speed selection (DI3,4)
- Ramp pair 1/2 selection (DI5)
- Run enable (DI6)

Output signals

- Analog output AO1: Speed
- Analog output AO2: Current
- Relay output 1: Ready
- Relay output 2: Running
- Relay output 3: Fault (-1)

Jumper setting

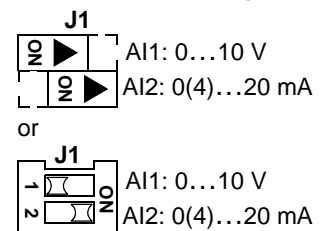

Motor Potentiometer macro

This macro provides a cost-effective interface for PLCs that vary the speed of the motor using only digital signals. To enable, set the value of parameter 9902 to 4 (MOTOR POT).

Connection example:

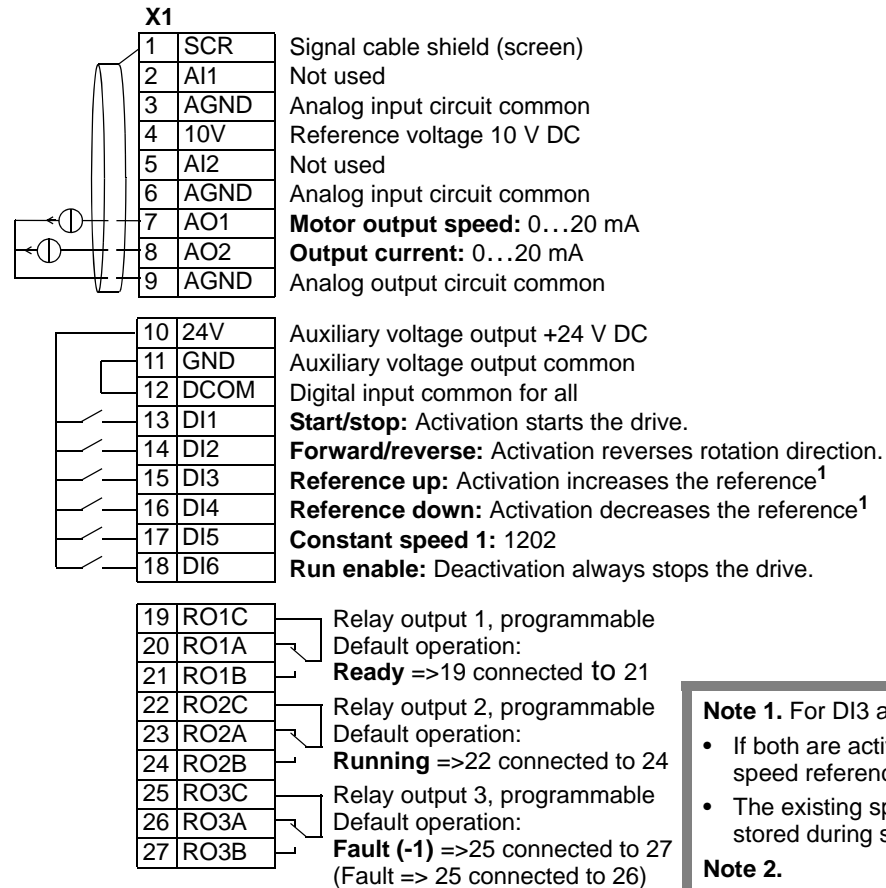

Note 1. For DI3 and DI4:

- If both are active or inactive the speed reference is unchanged.
- The existing speed reference is stored during stop or power down.

Note 2.

- Settings of the ramp times with acceleration and deceleration time 2 (parameters 2205 and 2206).

Input signals

- Start, stop and direction (DI1,2)
- Reference up/down (DI3,4)
- Constant speed selection (DI5)
- Run enable (DI6)

Output signals

- Analog output AO1: Speed
- Analog output AO2: Current
- Relay output 1: Ready
- Relay output 2: Running
- Relay output 3: Fault (-1)

Jumper setting

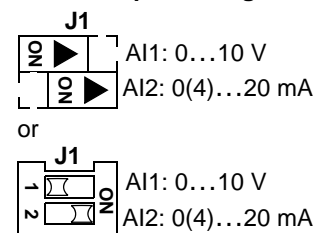

Hand-Auto macro

This macro provides an I/O configuration that is typically used in WW/W applications. To enable, set the value of parameter 9902 to 5 (HAND/AUTO).

Note: Parameter 2108 START INHIBIT must remain in the default setting, 0 (OFF).

Connection example:

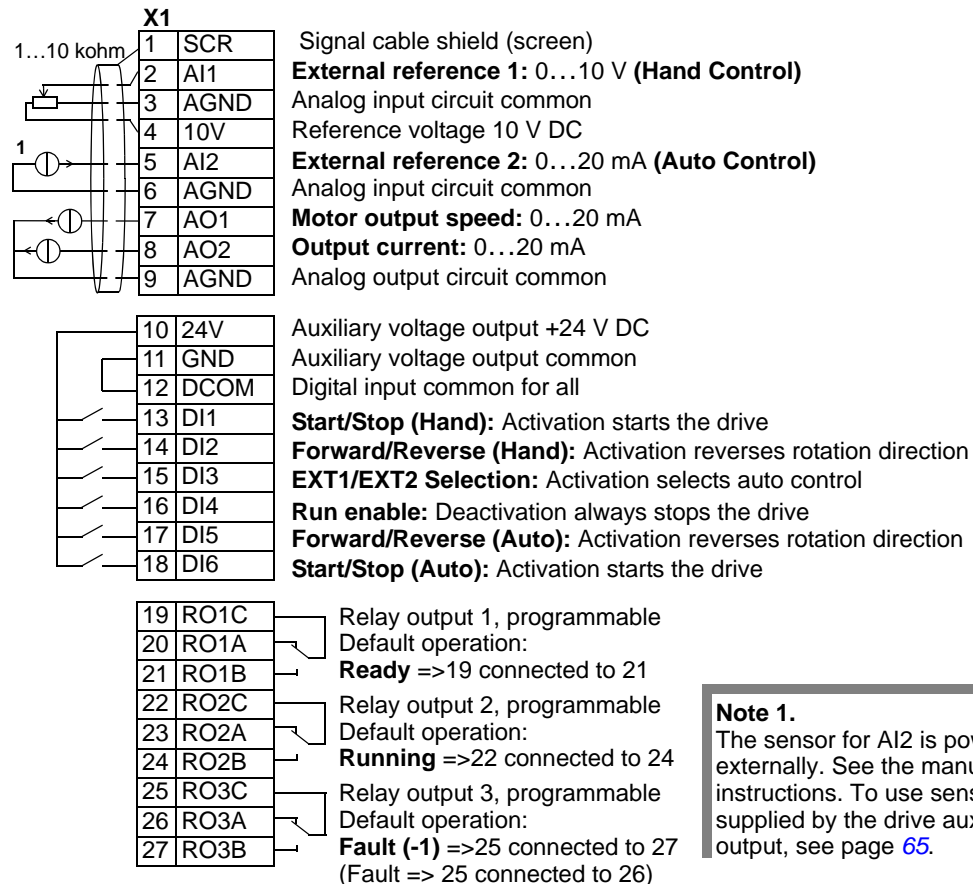

Note 1.

The sensor for AI2 is powered externally. See the manufacturer's instructions. To use sensors supplied by the drive aux. voltage output, see page 65.

Input signals

- Two analog references (AI1, 2)
- Start/stop – hand/auto (DI1, 6)
- Direction – hand/auto (DI2, 5)
- Control location selection (DI3)
- Run enable (DI4)

Output signals

- Analog output AO1: Speed
- Analog output AO2: Current
- Relay output 1: Ready
- Relay output 2: Running
- Relay output 3: Fault (-1)

Jumper setting

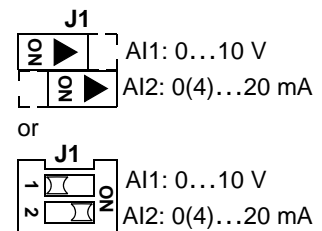

PID Control macro

This macro provides parameter settings for closed-loop control systems such as pressure control, flow control, etc. To enable, set the value of parameter 9902 to 6 (PID CONTROL).

Note: Parameter 2108 START INHIBIT must remain in the default setting, 0 (OFF).

Connection example:

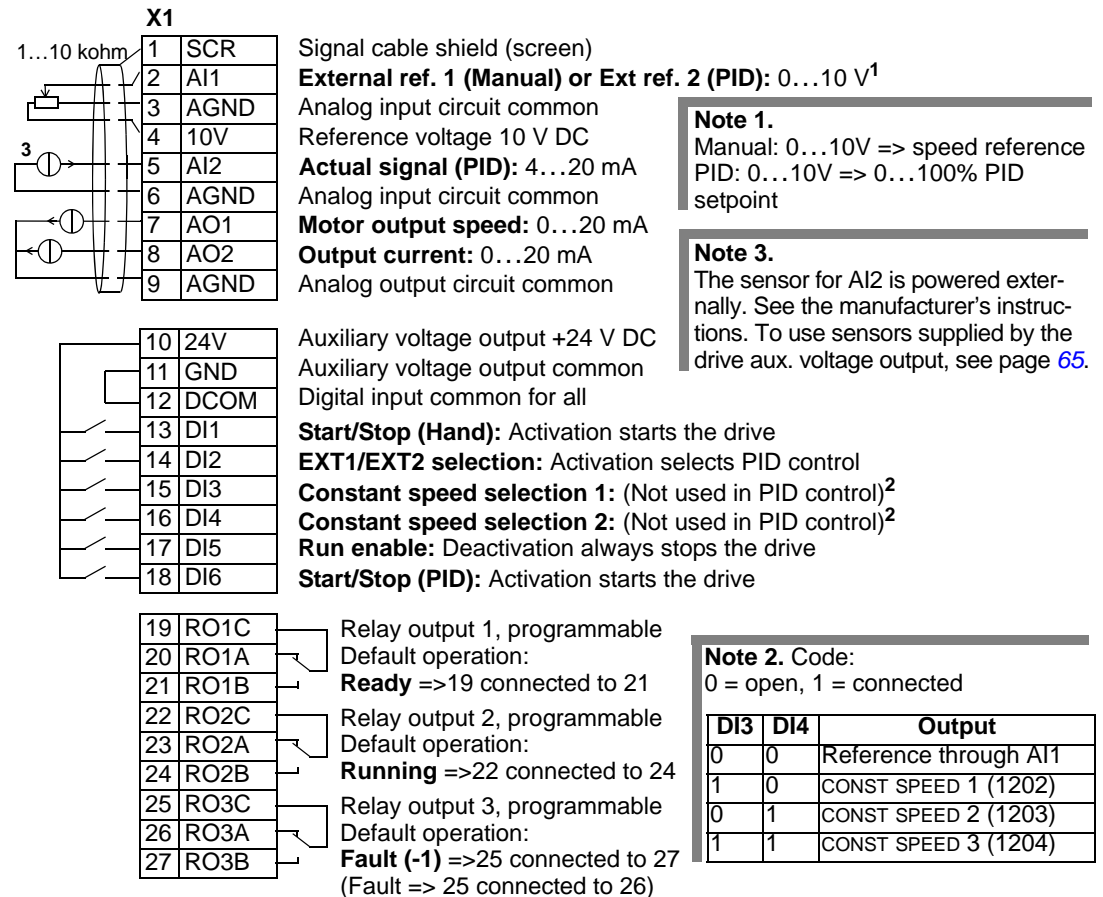

Input signals

- Analog reference (AI1)
- Actual value (AI2)
- Start/stop – hand/PID (DI1, 6)
- EXT1/EXT2 selection (DI2)
- Constant speed selection (DI3, 4)
- Run enable (DI5)

Output signals

- Analog output AO1: Speed
- Analog output AO2: Current
- Relay output 1: Ready
- Relay output 2: Running
- Relay output 3: Fault (-1)

Jumper setting

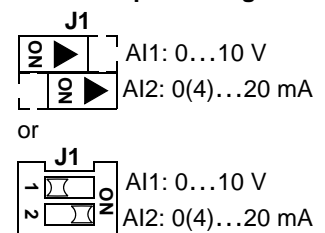

Note: Use the following switch-on order:

1. EXT1/EXT2
2. Run Enable
3. Start.

PFC macro

This macro provides parameter settings for pump and fan control (PFC) applications. To enable, set the value of parameter 9902 to 7 (PFC CONTROL).

Note: Parameter 2108 START INHIBIT must remain in the default setting, 0 (OFF).

Connection example:

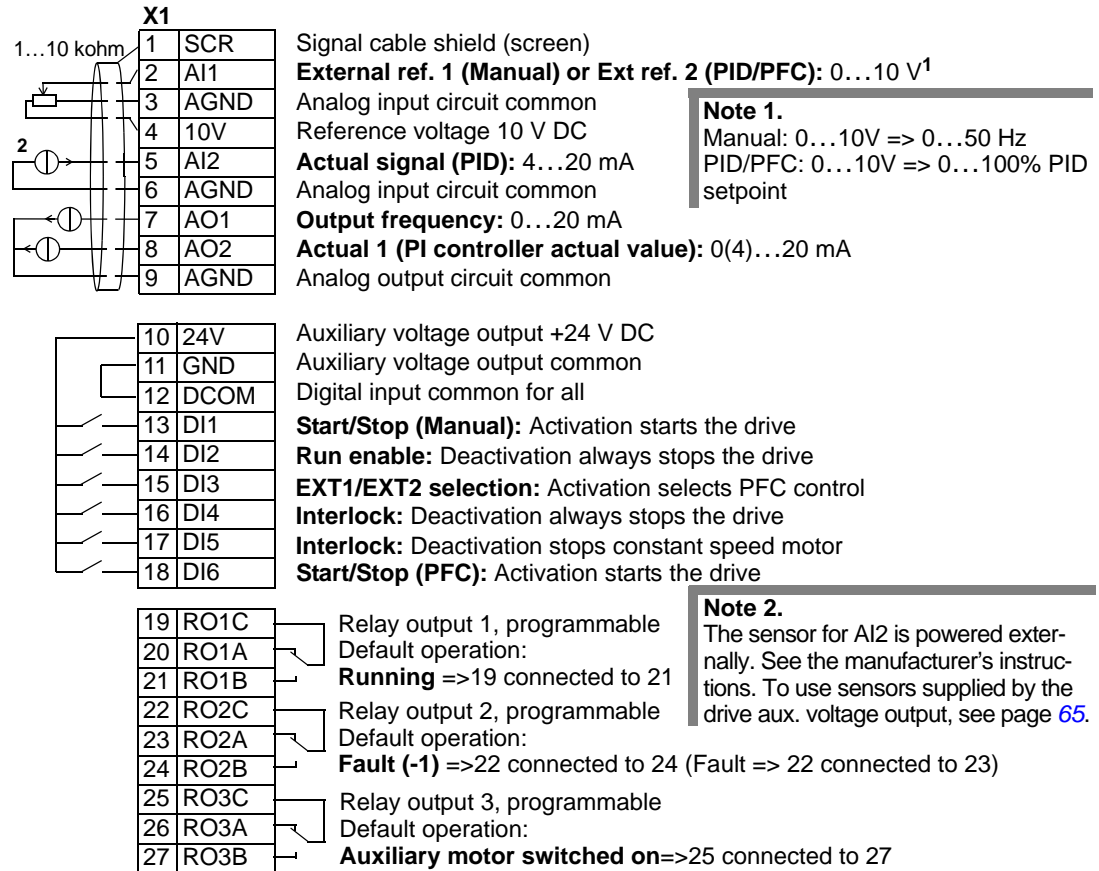

Note 1.
 Manual: 0...10V => 0...50 Hz
 PID/PFC: 0...10V => 0...100% PID setpoint

Note 2.
 The sensor for AI2 is powered externally. See the manufacturer's instructions. To use sensors supplied by the drive aux. voltage output, see page 65.

- | Input signals | Output signals | Jumper setting |
|--|---|---|
| <ul style="list-style-type: none"> Analog ref. and actual (AI1, 2) Start/stop – manual/PFC (DI1, 6) Run enable (DI2) EXT1/EXT2 selection (DI3) Interlock (DI4, 5) | <ul style="list-style-type: none"> Analog output AO1: Frequency Analog output AO2: Actual 1 Relay output 1: Running Relay output 2: Fault (-1) Relay output 3: Aux. motor ON | <p>J1</p> <p>AI1: 0...10 V
 AI2: 0(4)...20 mA</p> <p>or</p> <p>J1</p> <p>AI1: 0...10 V
 AI2: 0(4)...20 mA</p> |

Note: Use the following switch-on order:
 1. EXT1/EXT2
 2. Run Enable
 3. Start.

Connection examples of two-wire and three-wire sensors

Many applications use process PI(D) and need a feedback signal from the process. The feedback signal is typically connected to analog input 2 (AI2).

The macro wiring diagrams for each macro earlier in this chapter use an externally powered sensor (connections not shown). The figures below give examples of connections using a two-wire or three-wire sensor/transmitter supplied by the drive auxiliary voltage output.

Two-wire sensor/transmitter

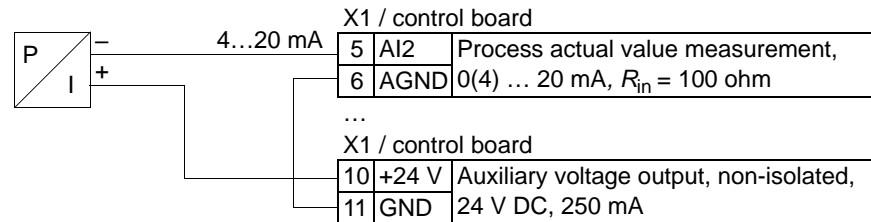

Note: The sensor is supplied through its current output and the drive feeds the supply voltage (+24 V). Thus the output signal must be 4...20 mA, not 0...20 mA

Three-wire sensor/transmitter

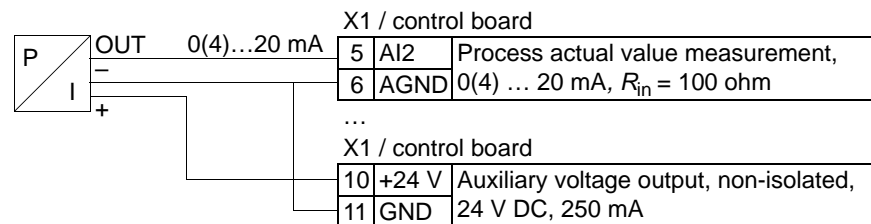

User parameter sets

In addition to the standard application macros, it is possible to save two user parameter sets into the permanent memory and load them at a later time. A user parameter set consists of the user parameter settings, including [Group 99: START-UP DATA](#), and the results of the motor identification. The panel reference is also saved if the user parameter set is saved and loaded in local control. The remote control setting is saved into the user parameter set, but the local control setting is not.

The steps below show how to save and load User Parameter Set 1. The procedure for User Parameter Set 2 is identical, only the parameter [9902](#) values are different.

To save User Parameter Set 1:

- Adjust the parameters. Perform the motor identification if it is needed in the application but it is not done yet.
- Save the parameter settings and the results of the motor identification to the permanent memory by changing parameter [9902](#) to -1 (USER S1 SAVE).
- Press  (ACQ Control Panel).

To load User Parameter Set 1:

- Change parameter [9902](#) to 0 (USER S1 LOAD).
- Press  (ACQ Control Panel).

The user parameter set can also be switched through digital inputs (see parameter [1605](#)).

Note: Loading the user parameter set restores the parameter settings including [Group 99: START-UP DATA](#) and the results of the motor identification. Check that the settings correspond to the motor used.

Hint: The user can for example switch the drive between two motors without having to adjust the motor parameters and to repeat the motor identification every time the motor is changed. The user needs only to adjust the settings and perform the motor identification once for each motor and then to save the data as two user parameter sets. When the motor is changed, only the corresponding user parameter set needs to be loaded, and the drive is ready to operate.

Macro default values for parameters

Parameter default values are listed in section [Complete parameter list](#) on page 69. Changing from the default macro (ABB Standard), that is, editing the value of parameter 9902, changes the parameter default values as defined in the following tables.

Note: Configured for 60 Hz/NEMA compliance (ACQ550-U1).

ACQ550-U1

Parameter	ABB 2-wire	3-wire	Alternate	Motor Potentiometer	Hand-auto	PID Control	PFC Control	
9902	APPLIC MACRO	1 = ABB STANDARD	2 = 3-WIRE	3 = ALTERNATE	4 = MOTOR POT	5 = HAND/AUTO	6 = PID CONTROL	7 = PFC CONTROL
9904	MOTOR CTRL MODE	3 = SCALAR: FREQ	1 = VECTOR: SPEED	1 = VECTOR: SPEED	1 = VECTOR: SPEED	1 = VECTOR: SPEED	3 = SCALAR: FREQ	
1001	EXT1 COMMANDS	2 = DI1,2	4 = DI1P,2P,3	9 = DI1F,2R	2 = DI1,2	2 = DI1,2	1 = DI1	1 = DI1
1002	EXT2 COMMANDS	0 = NOT SEL	0 = NOT SEL	0 = NOT SEL	0 = NOT SEL	7 = DI6,5	6 = DI6	6 = DI6
1003	DIRECTION	3 = REQUEST	3 = REQUEST	3 = REQUEST	3 = REQUEST	3 = REQUEST	1 = FORWARD	1 = FORWARD
1102	EXT1/EXT2 SEL	0 = EXT1	0 = EXT1	0 = EXT1	0 = EXT1	3 = DI3	2 = DI2	3 = DI3
1103	REF1 SELECT	1 = AI1	1 = AI1	1 = AI1	12 = DI3U,4D(NC)	1 = AI1	1 = AI1	1 = AI1
1106	REF2 SELECT	2 = AI2	2 = AI2	2 = AI2	2 = AI2	19 = PID1OUT	19 = PID1OUT	
1201	CONST SPEED SEL	9 = DI3,4	10 = DI4,5	9 = DI3,4	5 = DI5	0 = NOT SEL	9 = DI3,4	0 = NOT SEL
1304	MINIMUM AI2	0.0%	0.0%	0.0%	0.0%	20.0%	20.0%	20.0%
1401	RELAY OUTPUT 1	1 = READY	1 = READY	1 = READY	1 = READY	1 = READY	1 = READY	2 = RUN
1402	RELAY OUTPUT 2	2 = RUN	2 = RUN	2 = RUN	2 = RUN	2 = RUN	2 = RUN	3 = FAULT(-1)
1403	RELAY OUTPUT 3	3 = FAULT(-1)	3 = FAULT(-1)	3 = FAULT(-1)	3 = FAULT(-1)	3 = FAULT(-1)	3 = FAULT(-1)	31 = PFC
1501	AO1 CONTENT SEL	103 = 0103 OUTPUT FREQ	102 = 0102 SPEED	102 = 0102 SPEED	102 = 0102 SPEED	102 = 0102 SPEED	102 = 0102 SPEED	103 = 0103 OUTPUT FREQ
1507	AO2 CONTENT SEL	104 = CURRENT	104 = CURRENT	104 = CURRENT	104 = CURRENT	104 = CURRENT	104 = CURRENT	130 = PID 1 FBK
1510	MINIMUM AO2	0.0 mA	0.0 mA	0.0 mA	0.0 mA	0.0 mA	0.0 mA	4.0 mA
1601	RUN ENABLE	0 = NOT SEL	0 = NOT SEL	6 = DI6	6 = DI6	4 = DI4	5 = DI5	2 = DI2
2201	ACC/DEC 1/2 SEL	5 = DI5	0 = NOT SEL	5 = DI5	0 = NOT SEL	0 = NOT SEL	0 = NOT SEL	0 = NOT SEL
3201	SUPERV 1 PARAM	103 = 0103 OUTPUT FREQ	102 = 0102 SPEED	102 = 0102 SPEED	102 = 0102 SPEED	102 = 0102 SPEED	102 = 0102 SPEED	103 = 0103 OUTPUT FREQ
3401	SIGNAL1 PARAM	103 = 0103 OUTPUT FREQ	102 = 0102 SPEED	102 = 0102 SPEED	102 = 0102 SPEED	102 = 0102 SPEED	102 = 0102 SPEED	103 = 0103 OUTPUT FREQ
4001	GAIN	1.0	1.0	1.0	1.0	1.0	1.0	2.5
4002	INTEGRATION TIME	60.0 s	60.0 s	60.0 s	60.0 s	60.0 s	60.0 s	3.0 s
4101	GAIN	1.0	1.0	1.0	1.0	1.0	1.0	2.5
4102	INTEGRATION TIME	60.0 s	60.0 s	60.0 s	60.0 s	60.0 s	60.0 s	3.0 s
8123	PFC ENABLE	0 = NOT SEL	0 = NOT SEL	0 = NOT SEL	0 = NOT SEL	0 = NOT SEL	0 = NOT SEL	1 = ACTIVE

Parameters

Complete parameter list

The following table lists all parameters. Table header abbreviations are:

- S = Parameters can be modified only when the drive is stopped.
- User = Space to enter desired parameter values.

Some values depend on the “construction” as indicated in the table by

“-U1:” = Setup and parts specific to US installation and NEMA compliance.

Refer to the type designation on the drive, for example ACQ550-U1-08A8-4.

Code	Name	Range	Resolution	Default	User	S
Group 99: START-UP DATA						
9901	LANGUAGE	0...16 / 0...3	1	0 (ENGLISH)		
9902	APPLIC MACRO	-3...7	1	6 (PID CONTROL)		✓
9904	MOTOR CTRL MODE	1 or 2 = VECTOR:SPEED, 3 = SCALAR:FREQ	1	3 (SCALAR:FREQ)		✓
9905	MOTOR NOM VOLT	-U1-yyyy-2: 115...345 V -U1-yyyy-4: 230...690 V -U1-yyyy-6: 288...862 V	1 V	-U1-yyyy-2: 230 V -U1-yyyy-4: 460 V -U1-yyyy-6: 575 V		✓
9906	MOTOR NOM CURR	$0.2 \cdot I_{2hd} \dots 2.0 \cdot I_{2hd}$	0.1 A	$1.0 \cdot I_{2hd}$		✓
9907	MOTOR NOM FREQ	10.0...500.0 Hz	0.1 Hz	-U1: 60.0 Hz		✓
9908	MOTOR NOM SPEED	50...30000 rpm	1 rpm	Size dependent		✓
9909	MOTOR NOM POWER	$0.2 \dots 3.0 \cdot P_{hd}$	-U1: 0.1 hp	$1.0 \cdot P_{hd}$		✓
9910	ID RUN	0 = OFF/IDMAGN, 1 = ON	1	0 (OFF/IDMAGN)		✓
9915	MOTOR COSPHI	0 = IDENTIFIED, 0.01...0.97	0.01	0 (IDENTIFIED)		✓
Group 01: OPERATING DATA						
0101	SPEED & DIR	-30000...30000 rpm	1 rpm	-		
0102	SPEED	0...30000 rpm	1 rpm	-		
0103	OUTPUT FREQ	0.0...500.0 Hz	0.1 Hz	-		
0104	CURRENT	$0.0 \dots 2.0 \cdot I_{2hd}$	0.1 A	-		
0105	TORQUE	-200.0...200.0%	0.1%	-		
0106	POWER	$-2.0 \dots 2.0 \cdot P_{hd}$	0.1 kW	-		
0107	DC BUS VOLTAGE	$0 \dots 2.5 \cdot V_{dN}$	1 V	-		
0109	OUTPUT VOLTAGE	$0 \dots 2.0 \cdot V_{dN}$	1 V	-		
0110	DRIVE TEMP	0.0...150.0 °C	0.1 °C	-		
0111	EXTERNAL REF 1	0.0...500.0 Hz / 0...30000 rpm	0.1 Hz / 1 rpm	-		
0112	EXTERNAL REF 2	0.0...100.0% (0.0...600.0% for torque)	0.1%	-		
0113	CTRL LOCATION	0 = LOCAL, 1 = EXT1, 2 = EXT2	1	-		
0114	RUN TIME (R)	0...9999 h	1 h	-		
0115	KWH COUNTER (R)	0...65535 kWh	1 kWh	-		
0116	APPL BLK OUTPUT	0.0...100.0% (0.0...600.0% for torque)	0.1%	-		
0118	DI 1-3 STATUS	000...111 (0...7 decimal)	1	-		

Code	Name	Range	Resolution	Default	User	S
0119	DI 4-6 STATUS	000...111 (0...7 decimal)	1	-		
0120	AI 1	0.0...100.0%	0.1%	-		
0121	AI 2	0.0...100.0%	0.1%	-		
0122	RO 1-3 STATUS	000...111 (0...7 decimal)	1	-		
0123	RO 4-6 STATUS	000...111 (0...7 decimal)	1	-		
0124	AO 1	0.0...20.0 mA	0.1 mA	-		
0125	AO 2	0.0...20.0 mA	0.1 mA	-		
0126	PID 1 OUTPUT	-1000.0...1000.0%	0.1%	-		
0127	PID 2 OUTPUT	-100.0...100.0%	0.1%	-		
0128	PID 1 SETPNT	Unit and scale defined by par. 4006/ 4106 and 4007/4107	-	-		
0129	PID 2 SETPNT	Unit and scale defined by par. 4206 and 4207	-	-		
0130	PID 1 FBK	Unit and scale defined by par. 4006/ 4106 and 4007/4107	-	-		
0131	PID 2 FBK	Unit and scale defined by par. 4206 and 4207	-	-		
0132	PID 1 DEVIATION	Unit and scale defined by par. 4006/ 4106 and 4007/4107	-	-		
0133	PID 2 DEVIATION	Unit and scale defined by par. 4206 and 4207	-	-		
0134	COMM RO WORD	0...65535	1	-		
0135	COMM VALUE 1	-32768...+32767	1	-		
0136	COMM VALUE 2	-32768...+32767	1	-		
0137	PROCESS VAR 1	-	1			
0138	PROCESS VAR 2	-	1			
0139	PROCESS VAR 3	-	1			
0140	RUN TIME	0.00...499.99 kh	0.01 kh	-		
0141	MWH COUNTER	0...65535 MWh	1 MWh	-		
0142	REVOLUTION CNTR	0...65535 Mrev	1 Mrev	-		
0143	DRIVE ON TIME HI	0...65535 days	1 day	-		
0144	DRIVE ON TIME LO	00:00:00...23:59:58	1 = 2 s	-		
0145	MOTOR TEMP	Par. 3501 = 1...3: -10...200 °C Par. 3501 = 4: 0...5000 ohm Par. 3501 = 5...6: 0...1	1	-		
0146	MECH ANGLE	0...32768	1	-		
0147	MECH REVS	-32768 ...+32767	1	-		
0148	Z PLS DETECTED	0 = NOT DETECTED, 1 = DETECTED	1	-		
0150	CB TEMP	-20.0...150.0 °C	1.0 °C	-		
0153	MOT THERM STRESS	0.0...100.0%	0.1%	-		
0158	PID COMM VALUE 1	-32768 ...+32767	1	-		
0159	PID COMM VALUE 2	-32768 ...+32767	1	-		
0174	SAVED KWH	0.0...999.9 kWh	0.1 kWh	-		
0175	SAVED MWH	0...65535 MWh	1 MWh	-		
0176	SAVED AMOUNT 1	0.0...999.9	0.1	-		
0177	SAVED AMOUNT 2	0...65535	1	-		
0178	SAVED CO2	0.0...6553.5 tn	0.1 tn	-		

Code	Name	Range	Resolution	Default	User	S
Group 03: FB ACTUAL SIGNALS						
0301	FB CMD WORD 1	-	-	-		
0302	FB CMD WORD 2	-	-	-		
0303	FB STS WORD 1	-	-	-		
0304	FB STS WORD 2	-	1	-		
0305	FAULT WORD 1	-	1	-		
0306	FAULT WORD 2	-	1	-		
0307	FAULT WORD 3	-	1	-		
0308	ALARM WORD 1	-	1	-		
0309	ALARM WORD 2	-	1	-		
Group 04: FAULT HISTORY						
0401	LAST FAULT	Fault codes (panel displays as text)	1	0		
0402	FAULT TIME 1	Date dd.mm.yy / power-on time in days	1 day	0		
0403	FAULT TIME 2	Time hh.mm.ss	2 s	0		
0404	SPEED AT FLT	-32768...+32767	1 rpm	0		
0405	FREQ AT FLT	-3276.8...+3276.7	0.1 Hz	0		
0406	VOLTAGE AT FLT	0.0...6553.5	0.1 V	0		
0407	CURRENT AT FLT	0.0...6553.5	0.1 A	0		
0408	TORQUE AT FLT	-3276.8...+3276.7	0.1%	0		
0409	STATUS AT FLT	0000...FFFF hex	1	0		
0410	DI 1-3 AT FLT	000...111 (0...7 decimal)	1	0		
0411	DI 4-6 AT FLT	000...111 (0...7 decimal)	1	0		
0412	PREVIOUS FAULT 1	As par. 0401	1	0		
0413	PREVIOUS FAULT 2	As par. 0401	1	0		
Group 10: START/STOP/DIR						
1001	EXT1 COMMANDS	0...14	1	2 (DI1,2)		✓
1002	EXT2 COMMANDS	0...14	1	0 (NOT SEL)		✓
1003	DIRECTION	1 = FORWARD, 2 = REVERSE, 3 = REQUEST	1	1 = FORWARD		✓
1004	JOGGING SEL	-6...6	1	0 (NOT SEL)		✓
Group 11: REFERENCE SELECT						
1101	KEYPAD REF SEL	1 = REF1(Hz/rpm), 2 = REF2(%)	1	1 [REF1(Hz/rpm)]		
1102	EXT1/EXT2 SEL	-6...12	1	0 (EXT1)		✓
1103	REF1 SELECT	0...17, 20...21	1	1 (AI1)		✓
1104	REF1 MIN	0.0...500.0 Hz / 0...30000 rpm	0.1 Hz / 1 rpm	0.0 Hz / 0 rpm		
1105	REF1 MAX	0.0...500.0 Hz / 0...30000 rpm	0.1 Hz / 1 rpm	-U1: 60.0 (62.0) Hz / 1800 rpm		
1106	REF2 SELECT	0...17, 19...21	1	19 (PID1OUT)		✓
1107	REF2 MIN	0.0...100.0% (0.0...600.0% for torque)	0.1%	0.0%		
1108	REF2 MAX	0.0...100.0% (0.0...600.0% for torque)	0.1%	100.0%		
Group 12: CONSTANT SPEEDS						
1201	CONST SPEED SEL	-14 ...19	1	9 (DI3,4)		✓
1202	CONST SPEED 1	0.0...500.0 Hz / 0...30000 rpm	0.1 Hz / 1 rpm	-U1: 6.0 Hz / 360 rpm		
1203	CONST SPEED 2	0.0...500.0 Hz / 0...30000 rpm	0.1 Hz / 1 rpm	-U1: 12.0 Hz / 720 rpm		
1204	CONST SPEED 3	0.0...500.0 Hz / 0...30000 rpm	0.1 Hz / 1 rpm	-U1: 18.0 Hz / 1080 rpm		

Code	Name	Range	Resolution	Default	User	S
1205	CONST SPEED 4	0.0...500.0 Hz / 0...30000 rpm	0.1 Hz / 1 rpm	-U1: 24.0 Hz / 1440 rpm		
1206	CONST SPEED 5	0.0...500.0 Hz / 0...30000 rpm	0.1 Hz / 1 rpm	-U1: 30.0 Hz / 1800 rpm		
1207	CONST SPEED 6	0.0...500.0 Hz / 0...30000 rpm	0.1 Hz / 1 rpm	-U1: 48.0 Hz / 2880 rpm		
1208	CONST SPEED 7	0.0...500.0 Hz / 0...30000 rpm	0.1 Hz / 1 rpm	-U1: 60.0 Hz / 3600 rpm		
1209	TIMED MODE SEL	1 = EXT/CS1/2/3, 2 = CS1/2/3/4	1	2 (CS1/2/3/4)		✓
Group 13: ANALOG INPUTS						
1301	MINIMUM AI1	0.0...100.0%	0.1%	0.0%		
1302	MAXIMUM AI1	0.0...100.0%	0.1%	100.0%		
1303	FILTER AI1	0.0...10.0 s	0.1 s	0.1 s		
1304	MINIMUM AI2	0.0...100.0%	0.1%	20.0%		
1305	MAXIMUM AI2	0.0...100.0%	0.1%	100.0%		
1306	FILTER AI2	0.0...10.0 s	0.1 s	0.1 s		
Group 14: RELAY OUTPUTS						
1401	RELAY OUTPUT 1	0...44, 46, 47, 52	1	1 (READY)		
1402	RELAY OUTPUT 2	0...44, 46, 47, 52	1	2 (RUN)		
1403	RELAY OUTPUT 3	0...44, 46, 47, 52	1	3 [FAULT(-1)]		
1404	RO 1 ON DELAY	0.0...3600.0 s	0.1 s	0.0 s		
1405	RO 1 OFF DELAY	0.0...3600.0 s	0.1 s	0.0 s		
1406	RO 2 ON DELAY	0.0...3600.0 s	0.1 s	0.0 s		
1407	RO 2 OFF DELAY	0.0...3600.0 s	0.1 s	0.0 s		
1408	RO 3 ON DELAY	0.0...3600.0 s	0.1 s	0.0 s		
1409	RO 3 OFF DELAY	0.0...3600.0 s	0.1 s	0.0 s		
1410	RELAY OUTPUT 4	0...44, 46, 47, 52	1	0 (NOT SEL)		
1411	RELAY OUTPUT 5	0...44, 46, 47, 52	1	0 (NOT SEL)		
1412	RELAY OUTPUT 6	0...44, 46, 47, 52	1	0 (NOT SEL)		
1413	RO 4 ON DELAY	0.0...3600.0 s	0.1 s	0.0 s		
1414	RO 4 OFF DELAY	0.0...3600.0 s	0.1 s	0.0 s		
1415	RO 5 ON DELAY	0.0...3600.0 s	0.1 s	0.0 s		
1416	RO 5 OFF DELAY	0.0...3600.0 s	0.1 s	0.0 s		
1417	RO 6 ON DELAY	0.0...3600.0 s	0.1 s	0.0 s		
1418	RO 6 OFF DELAY	0.0...3600.0 s	0.1 s	0.0 s		
Group 15: ANALOG OUTPUTS						
1501	AO1 CONTENT SEL	99...178	1	102 (parameter 0102 OUTPUT SPEED)		
1502	AO1 CONTENT MIN	-	-	Depends on the signal selected with par. 1501		
1503	AO1 CONTENT MAX	-	-	Depends on the signal selected with par. 1501		
1504	MINIMUM AO1	0.0...20.0 mA	0.1 mA	0.0 mA		
1505	MAXIMUM AO1	0.0...20.0 mA	0.1 mA	20.0 mA		
1506	FILTER AO1	0.0...10.0 s	0.1 s	0.1 s		
1507	AO2 CONTENT SEL	99...178	1	104 (parameter 0104 CURRENT)		
1508	AO2 CONTENT MIN	-	-	Depends on the signal selected with par. 1507		
1509	AO2 CONTENT MAX	-	-	Depends on the signal selected with par. 1507		

Code	Name	Range	Resolution	Default	User	S
1510	MINIMUM AO2	0.0...20.0 mA	0.1 mA	0.0 mA		
1511	MAXIMUM AO2	0.0...20.0 mA	0.1 mA	20.0 mA		
1512	FILTER AO2	0.0...10.0 s	0.1 s	0.1 s		
Group 16: SYSTEM CONTROLS						
1601	RUN ENABLE	-6...7	1	0 (NOT SEL)		✓
1602	PARAMETER LOCK	0 = LOCKED, 1 = OPEN, 2 = NOT SAVED	1	1 (OPEN)		
1603	PASS CODE	0...65535	1	0		
1604	FAULT RESET SEL	-6...8	1	0 (KEYPAD)		
1605	USER PAR SET CHG	-6...6	1	0 (NOT SEL)		
1606	LOCAL LOCK	-6...8	1	0 (NOT SEL)		
1607	PARAM SAVE	0 = DONE, 1 = SAVE...	1	0 (DONE)		
1608	START ENABLE 1	-6...7	1	0 (NOT SEL)		✓
1609	START ENABLE 2	-6...7	1	0 (NOT SEL)		✓
1610	DISPLAY ALARMS	0 = NO, 1 = YES	1	0 (NO)		
1611	PARAMETER VIEW	0 = DEFAULT	1	0 (DEFAULT)		
1612	FAN CONTROL	0 = AUTO, 1 = ON	1	0 (DEFAULT)		
1613	FAULT RESET	0 = DEFAULT, 1 = RESET NOW	1	0 (DEFAULT)		
Group 20: LIMITS						
2001	MINIMUM SPEED	-30000...30000 rpm	1 rpm	0 rpm		✓
2002	MAXIMUM SPEED	0...30000 rpm	1 rpm	-U1: 1800 rpm		✓
2003	MAX CURRENT	0... $1.8 \cdot I_{2hd}$	0.1 A	$1.8 \cdot I_{2hd}$		✓
2005	OVERVOLT CTRL	0 = DISABLE, 1 = ENABLE	1	1 (ENABLE)		
2006	UNDERVOLT CTRL	0 = DISABLE, 1 = ENABLE(TIME), 2 = ENABLE	1	1 [ENABLE(TIME)]		
2007	MINIMUM FREQ	-500.0...500.0 Hz	0.1 Hz	0.0 Hz		✓
2008	MAXIMUM FREQ	0.0...500.0 Hz	0.1 Hz	-U1: 60.0 (62.0) Hz		✓
2013	MIN TORQUE SEL	-6...7	1	0 (MIN TORQUE 1)		
2014	MAX TORQUE SEL	-6...7	1	0 (MAX TORQUE 1)		
2015	MIN TORQUE 1	-600.0...0.0%	0.1%	-300.0%		
2016	MIN TORQUE 2	-600.0...0.0%	0.1%	-300.0%		
2017	MAX TORQUE 1	0.0...600.0%	0.1%	300.0%		
2018	MAX TORQUE 2	0.0...600.0%	0.1%	300.0%		
Group 21: START/STOP						
2101	START FUNCTION	Vector control modes: 1, 2, 8 Scalar control mode: 1...5, 8	1	8 (RAMP)		✓
2102	STOP FUNCTION	1 = COAST, 2 = RAMP	1	1 (COAST)		
2103	DC MAGN TIME	0.00...10.00 s	0.01 s	0.30 s		
2104	DC HOLD CTL	0 = NOT SEL, 1 = DC HOLD, 2 = DC BRAKING	1	0 (NOT SEL)		✓
2105	DC HOLD SPEED	0...360 rpm	1 rpm	5 rpm		
2106	DC CURR REF	0...100%	1%	30%		
2107	DC BRAKE TIME	0.0...250.0 s	0.1 s	0.0 s		
2108	START INHIBIT	0 = OFF, 1 = ON	1	0 (OFF)		
2109	EMERG STOP SEL	-6...6	1	0 (NOT SEL)		
2110	TORQ BOOST CURR	15...300%	1%	100%		
2112	ZERO SPEED DELAY	0.0 = NOT SEL, 0.1...60.0 s	0.1 s	0.0 s (NOT SEL)		

Code	Name	Range	Resolution	Default	User	S
2113	START DELAY	0.00...60.00 s	0.01 s	0.00 s		
Group 22: ACCEL/DECEL						
2201	ACC/DEC 1/2 SEL	-6...7	1	0 (NOT SEL)		
2202	ACCELER TIME 1	0.0...1800.0 s	0.1 s	5.0 s		
2203	DECELER TIME 1	0.0...1800.0 s	0.1 s	5.0 s		
2204	RAMP SHAPE 1	0.0 = LINEAR, 0.1...1000.0 s	0.1 s	0.0 s		
2205	ACCELER TIME 2	0.0...1800.0 s	0.1 s	60.0 s		
2206	DECELER TIME 2	0.0...1800.0 s	0.1 s	60.0 s		
2207	RAMP SHAPE 2	0.0 = LINEAR, 0.1...1000.0 s	0.1 s	0.0 s		
2208	EMERG DEC TIME	0.0...1800.0 s	0.1 s	1.0 s		
2209	RAMP INPUT 0	-6...7	1	0 (NOT SEL)		
Group 23: SPEED CONTROL						
2301	PROP GAIN	0.00...200.00	0.01	5.00		
2302	INTEGRATION TIME	0.00...600.00 s	0.01 s	0.50 s		
2303	DERIVATION TIME	0...10000 ms	1 ms	0 ms		
2304	ACC COMPENSATION	0.00...600.00 s	0.01 s	0.00 s		
2305	AUTOTUNE RUN	0 = OFF, 1 = ON	1	0 (OFF)		
Group 25: CRITICAL SPEEDS						
2501	CRIT SPEED SEL	0 = OFF, 1 = ON	1	0 (OFF)		
2502	CRIT SPEED 1 LO	0.0...500.0 Hz / 0...30000 rpm	0.1 Hz / 1 rpm	0.0 Hz / 0 rpm		
2503	CRIT SPEED 1 HI	0.0...500.0 Hz / 0...30000 rpm	0.1 Hz / 1 rpm	0.0 Hz / 0 rpm		
2504	CRIT SPEED 2 LO	0.0...500.0 Hz / 0...30000 rpm	0.1 Hz / 1 rpm	0.0 Hz / 0 rpm		
2505	CRIT SPEED 2 HI	0.0...500.0 Hz / 0...30000 rpm	0.1 Hz / 1 rpm	0.0 Hz / 0 rpm		
2506	CRIT SPEED 3 LO	0.0...500.0 Hz / 0...30000 rpm	0.1 Hz / 1 rpm	0.0 Hz / 0 rpm		
2507	CRIT SPEED 3 HI	0.0...500.0 Hz / 0...30000 rpm	0.1 Hz / 1 rpm	0.0 Hz / 0 rpm		
Group 26: MOTOR CONTROL						
2601	FLUX OPT ENABLE	0 = OFF, 1 = ON	1	1 (ON)		
2602	FLUX BRAKING	0 = OFF, 1 = ON	1	0 (OFF)		
2603	IR COMP VOLT	0.0...100.0 V	0.1 V	Size dependent		
2604	IR COMP FREQ	0...100%	1%	80%		
2605	U/F RATIO	1 = LINEAR, 2 = SQUARED	1	2 (SQUARED)		
2606	SWITCHING FREQ	1, 2, 4, 8, 12 kHz	-	4 kHz		
2607	SWITCH FREQ CTRL	0 = OFF, 1 = ON	1	1 (ON)		
2608	SLIP COMP RATIO	0...200%	1%	0%		
2609	NOISE SMOOTHING	0 = DISABLE, 1 = ENABLE	1	0 (DISABLE)		
2619	DC STABILIZER	0 = DISABLE, 1 = ENABLE	1	0 (DISABLE)		
2625	OVERMODULATION	0 = DISABLE, 1 = ENABLE	1	0 (DISABLE)		
2627	FLUX STAB GAIN	0...5000	1	100		
2628	DC STAB GAIN	0...2000	1	25		
Group 29: MAINTENANCE TRIG						
2901	COOLING FAN TRIG	0.0...6553.5 kh, 0.0 disables	0.1 kh	0.0 kh		
2902	COOLING FAN ACT	0.0...6553.5 kh	0.1 kh	0.0 kh		
2903	REVOLUTION TRIG	0...65535 Mrev, 0 disables	1 Mrev	0 Mrev		
2904	REVOLUTION ACT	0...65535 Mrev	1 Mrev	0 Mrev		
2905	RUN TIME TRIG	0.0...6553.5 kh, 0.0 disables	0.1 kh	0.0 kh		

Code	Name	Range	Resolution	Default	User	S
2906	RUN TIME ACT	0.0...6553.5 kh	0.1 kh	0.0 kh		
2907	USER MWh TRIG	0.0...6553.5 MWh, 0.0 disables	0.1 MWh	0.0 MWh		
2908	USER MWh ACT	0.0...6553.5 MWh	0.1 MWh	0.0 MWh		
Group 30: FAULT FUNCTIONS						
3001	AI<MIN FUNCTION	0...3	1	0 (NOT SEL)		
3002	PANEL COMM ERR	1...3	1	1 (FAULT)		
3003	EXTERNAL FAULT 1	-6...6	1	0 (NOT SEL)		
3004	EXTERNAL FAULT 2	-6...6	1	0 (NOT SEL)		
3005	MOT THERM PROT	0 = NOT SEL, 1 = FAULT, 2 = ALARM	1	1 (FAULT)		
3006	MOT THERM TIME	256...9999 s	1 s	500 s		
3007	MOT LOAD CURVE	50...150%	1%	100%		
3008	ZERO SPEED LOAD	25...150%	1%	70%		
3009	BREAK POINT FREQ	1...250 Hz	1 Hz	35 Hz		
3010	STALL FUNCTION	0 = NOT SEL, 1 = FAULT, 2 = ALARM	1	0 (NOT SEL)		
3011	STALL FREQUENCY	0.5...50.0 Hz	0.1 Hz	20.0 Hz		
3012	STALL TIME	10...400 s	1 s	20 s		
3017	EARTH FAULT	0 = DISABLE, 1 = ENABLE	1	1 (ENABLE)		✓
3018	COMM FAULT FUNC	0 = NOT SEL, 1 = FAULT, 2 = CONST SP 7, 3 = LAST SPEED	1	0 (NOT SEL)		
3019	COMM FAULT TIME	0.0...600.0 s	0.1 s	3.0 s		
3021	AI1 FAULT LIMIT	0.0...100.0%	0.1%	0.0%		
3022	AI2 FAULT LIMIT	0.0...100.0%	0.1%	0.0%		
3023	WIRING FAULT	0 = DISABLE, 1 = ENABLE	1	1 (ENABLE)		✓
3024	CB TEMP FAULT	0 = DISABLE, 1 = ENABLE	1	1 (ENABLE)		
3028	EARTH FAULT LVL	1 = LOW, 2 = MEDIUM, 3 = HIGH	1	1 (LOW)		
Group 31: AUTOMATIC RESET						
3101	NUMBER OF TRIALS	0...5	1	5		
3102	TRIAL TIME	1.0...600.0 s	0.1 s	30.0 s		
3103	DELAY TIME	0.0...120.0 s	0.1 s	6.0 s		
3104	AR OVERCURRENT	0 = DISABLE, 1 = ENABLE	1	0 (DISABLE)		
3105	AR OVERVOLTAGE	0 = DISABLE, 1 = ENABLE	1	1 (ENABLE)		
3106	AR UNDERVOLTAGE	0 = DISABLE, 1 = ENABLE	1	1 (ENABLE)		
3107	AR AI<MIN	0 = DISABLE, 1 = ENABLE	1	1 (ENABLE)		
3108	AR EXTERNAL FLT	0 = DISABLE, 1 = ENABLE	1	1 (ENABLE)		
Group 32: SUPERVISION						
3201	SUPERV 1 PARAM	100 = NOT SELECTED, 101...178	1	102 (parameter 0102 OUTPUT SPEED)		
3202	SUPERV 1 LIM LO	-	-	Depends on the signal selected with par. 3201		
3203	SUPERV 1 LIM HI	-	-	Depends on the signal selected with par. 3201		
3204	SUPERV 2 PARAM	100 = NOT SELECTED, 101...178	1	104 (parameter 0104 CURRENT)		
3205	SUPERV 2 LIM LO	-	-	Depends on the signal selected with par. 3204		
3206	SUPERV 2 LIM HI	-	-	Depends on the signal selected with par. 3204		

Code	Name	Range	Resolution	Default	User	S
3207	SUPERV 3 PARAM	100 = NOT SELECTED, 101...178	1	105 (parameter 0105 TORQUE)		
3208	SUPERV 3 LIM LO	-	-	Depends on the signal selected with par. 3207		
3209	SUPERV 3 LIM HI	-	-	Depends on the signal selected with par. 3207		
Group 33: INFORMATION						
3301	FIRMWARE	0000...FFFF hex	1	Firmware version		
3302	LOADING PACKAGE	0000...FFFF hex	1	Type dependent		
3303	TEST DATE	yy.ww	0.01	-		
3304	DRIVE RATING	-	-	Type dependent		
3305	PARAMETER TABLE	0000...FFFF hex	1	Type dependent		
Group 34: PANEL DISPLAY						
3401	SIGNAL1 PARAM	100 = NOT SELECTED, 101...178	1	102 (parameter 0102 OUTPUT SPEED)		
3402	SIGNAL1 MIN	-	-	Depends on the signal selected with par. 3401		
3403	SIGNAL1 MAX	-	-	Depends on the signal selected with par. 3401		
3404	OUTPUT1 DSP FORM	0...9	1	9 (DIRECT)		
3405	OUTPUT1 UNIT	0...127	1	Depends on the signal selected with par. 3401		
3406	OUTPUT1 MIN	-	-	Depends on the signal selected with par. 3401		
3407	OUTPUT1 MAX	-	-	Depends on the signal selected with par. 3401		
3408	SIGNAL2 PARAM	100 = NOT SELECTED, 101...178	1	104 (parameter 0104 CURRENT)		
3409	SIGNAL2 MIN	-	-	Depends on the signal selected with par. 3408		
3410	SIGNAL2 MAX	-	-	Depends on the signal selected with par. 3408		
3411	OUTPUT2 DSP FORM	0...9	1	9 (DIRECT)		
3412	OUTPUT2 UNIT	0...127	1	Depends on the signal selected with par. 3408		
3413	OUTPUT2 MIN	-	-	Depends on the signal selected with par. 3408		
3414	OUTPUT2 MAX	-	-	Depends on the signal selected with par. 3408		
3415	SIGNAL3 PARAM	100 = NOT SELECTED, 101...178	1	105 (parameter 0105 TORQUE)		
3416	SIGNAL3 MIN	-	-	Depends on the signal selected with par. 3415		
3417	SIGNAL3 MAX	-	-	Depends on the signal selected with par. 3415		
3418	OUTPUT3 DSP FORM	0...9	1	9 (DIRECT)		
3419	OUTPUT3 UNIT	0...127	1	Depends on the signal selected with par. 3415		
3420	OUTPUT3 MIN	-	-	Depends on the signal selected with par. 3415		

Code	Name	Range	Resolution	Default	User	S
3421	OUTPUT3 MAX	-	-	Depends on the signal selected with par. 3415		
Group 35: MOTOR TEMP MEAS						
3501	SENSOR TYPE	0...6	1	0 (NONE)		
3502	INPUT SELECTION	1...8	1	1 (AI1)		
3503	ALARM LIMIT	Par. 3501 = 1...3: -10...200 °C Par. 3501 = 4: 0...5000 ohm Par. 3501 = 5...6: 0...1	1	110 °C / 1500 ohm / 0		
3504	FAULT LIMIT	Par. 3501 = 1...3: -10...200 °C Par. 3501 = 4: 0...5000 ohm Par. 3501 = 5...6: 0...1	1	130 °C / 4000 ohm / 0		
Group 36: TIMED FUNCTIONS						
3601	TIMERS ENABLE	-6...7	1	0 (NOT SEL)		
3602	START TIME 1	00:00:00...23:59:58	2 s	00:00:00		
3603	STOP TIME 1	00:00:00...23:59:58	2 s	00:00:00		
3604	START DAY 1	1...7	1	1 (MONDAY)		
3605	STOP DAY 1	1...7	1	1 (MONDAY)		
3606	START TIME 2	00:00:00...23:59:58	2 s	00:00:00		
3607	STOP TIME 2	00:00:00...23:59:58	2 s	00:00:00		
3608	START DAY 2	1...7	1	1 (MONDAY)		
3609	STOP DAY 2	1...7	1	1 (MONDAY)		
3610	START TIME 3	00:00:00...23:59:58	2 s	00:00:00		
3611	STOP TIME 3	00:00:00...23:59:58	2 s	00:00:00		
3612	START DAY 3	1...7	1	1 (MONDAY)		
3613	STOP DAY 3	1...7	1	1 (MONDAY)		
3614	START TIME 4	00:00:00...23:59:58	2 s	00:00:00		
3615	STOP TIME 4	00:00:00...23:59:58	2 s	00:00:00		
3616	START DAY 4	1...7	1	1 (MONDAY)		
3617	STOP DAY 4	1...7	1	1 (MONDAY)		
3622	BOOSTER SEL	-6...6	1	0 (NOT SEL)		
3623	BOOSTER TIME	00:00:00...23:59:58	2 s	00:00:00		
3626	TIMED FUNC 1...4 SRC	0...31	1	0 (NOT SEL)		
...						
3629						
Group 37: USER LOAD CURVE						
3701	USER LOAD C MODE	0...3	1	0 (NOT SEL)		
3702	USER LOAD C FUNC	1 = FAULT, 2 = ALARM	1	1 (FAULT)		
3703	USER LOAD C TIME	10...400 s	1 s	20 s		
3704	LOAD FREQ 1	0...500 Hz	1 Hz	5 Hz		
3705	LOAD TORQ LOW 1	0...600%	1%	10%		
3706	LOAD TORQ HIGH 1	0...600%	1%	300%		
3707	LOAD FREQ 2	0...500 Hz	1 Hz	25 Hz		
3708	LOAD TORQ LOW 2	0...600%	1%	15%		
3709	LOAD TORQ HIGH 2	0...600%	1%	300%		
3710	LOAD FREQ 3	0...500 Hz	1 Hz	43 Hz		
3711	LOAD TORQ LOW 3	0...600%	1%	25%		
3712	LOAD TORQ HIGH 3	0...600%	1%	300%		

Code	Name	Range	Resolution	Default	User	S
3713	LOAD FREQ 4	0...500 Hz	1 Hz	50 Hz		
3714	LOAD TORQ LOW 4	0...600%	1%	30%		
3715	LOAD TORQ HIGH 4	0...600%	1%	300%		
3716	LOAD FREQ 5	0...500 Hz	1 Hz	500 Hz		
3717	LOAD TORQ LOW 5	0...600%	1%	30%		
3718	LOAD TORQ HIGH 5	0...600%	1%	300%		
Group 40: PROCESS PID SET 1						
4001	GAIN	0.1...100.0	0.1	1.0		
4002	INTEGRATION TIME	0.0 = NOT SEL, 0.1...3600.0 s	0.1 s	60.0 s		
4003	DERIVATION TIME	0.0...10.0 s	0.1 s	0.0 s		
4004	PID DERIV FILTER	0.0...10.0 s	0.1 s	1.0 s		
4005	ERROR VALUE INV	0 = NO, 1 = YES	1	0 (NO)		
4006	UNITS	0...127	1	4 (%)		
4007	UNIT SCALE	0...4	1	1		
4008	0% VALUE	Unit and scale defined by par. 4006 and 4007	-	0.0		
4009	100% VALUE	Unit and scale defined by par. 4006 and 4007	-	100.0		
4010	SET POINT SEL	0...2, 8...17, 19...20	1	1 (AI1)		✓
4011	INTERNAL SETPNT	Unit and scale defined by par. 4006 and 4007	-	40.0		
4012	SETPOINT MIN	-500.0...500.0%	0.1%	0.0%		
4013	SETPOINT MAX	-500.0...500.0%	0.1%	100.0%		
4014	FBK SEL	1...13	1	1 (ACT1)		
4015	FBK MULTIPLIER	0.000 = NOT SEL, -32.768...32.767	0.001	0.000 (NOT SEL)		
4016	ACT1 INPUT	1...7	1	2 (AI2)		✓
4017	ACT2 INPUT	1...7	1	2 (AI2)		✓
4018	ACT1 MINIMUM	-1000...1000%	1%	0%		
4019	ACT1 MAXIMUM	-1000...1000%	1%	100%		
4020	ACT2 MINIMUM	-1000...1000%	1%	0%		
4021	ACT2 MAXIMUM	-1000...1000%	1%	100%		
4022	SLEEP SELECTION	-6...7	1	0 (NOT SEL)		
4023	PID SLEEP LEVEL	0.0...500.0 Hz / 0...30000 rpm	0.1 Hz / 1 rpm	0.0 Hz / 0 rpm		
4024	PID SLEEP DELAY	0.0...3600.0 s	0.1 s	60.0 s		
4025	WAKE-UP DEV	Unit and scale defined by par. 4006 and 4007	-	0.0		
4026	WAKE-UP DELAY	0.00...60.00 s	0.01 s	0.50 s		
4027	PID 1 PARAM SET	-6...14	1	0 (SET 1)		
Group 41: PROCESS PID SET 2						
4101	GAIN	0.1...100.0	0.1	1.0		
4102	INTEGRATION TIME	0.0 = NOT SEL, 0.1...3600.0 s	0.1 s	60.0 s		
4103	DERIVATION TIME	0.0...10.0 s	0.1 s	0.0 s		
4104	PID DERIV FILTER	0.0...10.0 s	0.1 s	1.0 s		
4105	ERROR VALUE INV	0 = NO, 1 = YES	1	0 (NO)		
4106	UNITS	0...127	1	4 (%)		
4107	UNIT SCALE	0...4	1	1		

Code	Name	Range	Resolution	Default	User	S
4108	0% VALUE	Unit and scale defined by par. 4106 and 4107	-	0.0		
4109	100% VALUE	Unit and scale defined by par. 4106 and 4107	-	100.0		
4110	SET POINT SEL	0...2, 8...17, 19...20	1	1 (AI1)		✓
4111	INTERNAL SETPNT	Unit and scale defined by par. 4106 and 4107	-	40.0		
4112	SETPOINT MIN	-500.0...500.0%	0.1%	0.0%		
4113	SETPOINT MAX	-500.0...500.0%	0.1%	100.0%		
4114	FBK SEL	1...13	1	1 (ACT1)		
4115	FBK MULTIPLIER	0.000 = NOT SEL, -32.768...32.767	0.001	0.000 (NOT SEL)		
4116	ACT1 INPUT	1...7	1	2 (AI2)		✓
4117	ACT2 INPUT	1...7	1	2 (AI2)		✓
4118	ACT1 MINIMUM	-1000...1000%	1%	0%		
4119	ACT1 MAXIMUM	-1000...1000%	1%	100%		
4120	ACT2 MINIMUM	-1000...1000%	1%	0%		
4121	ACT2 MAXIMUM	-1000...1000%	1%	100%		
4122	SLEEP SELECTION	-6...7	1	0 (NOT SEL)		
4123	PID SLEEP LEVEL	0.0...500.0 Hz / 0...30000 rpm	0.1 Hz / 1 rpm	0.0 Hz / 0 rpm		
4124	PID SLEEP DELAY	0.0...3600.0 s	0.1 s	60.0 s		
4125	WAKE-UP DEV	Unit and scale defined by par. 4106 and 4107	-	0.0		
4126	WAKE-UP DELAY	0.00...60.00 s	0.01 s	0.50 s		
Group 42: EXT / TRIM PID						
4201	GAIN	0.1...100.0	0.1	1.0		
4202	INTEGRATION TIME	0.0 = NOT SEL, 0.1...3600.0 s	0.1 s	60.0 s		
4203	DERIVATION TIME	0.0...10.0 s	0.1 s	0.0 s		
4204	PID DERIV FILTER	0.0...10.0 s	0.1 s	1.0 s		
4205	ERROR VALUE INV	0 = NO, 1 = YES	1	0 (NO)		
4206	UNITS	0...127	1	4 (%)		
4207	UNIT SCALE	0...4	1	1		
4208	0% VALUE	Unit and scale defined by par. 4206 and 4207	-	0.0		
4209	100% VALUE	Unit and scale defined by par. 4206 and 4207	-	100.0		
4210	SET POINT SEL	0...2, 8...17, 19...20	1	1 (AI1)		✓
4211	INTERNAL SETPNT	Unit and scale defined by par. 4206 and 4207	-	40.0		
4212	SETPOINT MIN	-500.0...500.0%	0.1%	0.0%		
4213	SETPOINT MAX	-500.0...500.0%	0.1%	100.0%		
4214	FBK SEL	1...13	1	1 (ACT1)		
4215	FBK MULTIPLIER	0.000 = NOT SEL, -32.768...32.767	0.001	0.000 (NOT SEL)		
4216	ACT1 INPUT	1...7	1	2 (AI2)		✓
4217	ACT2 INPUT	1...7	1	2 (AI2)		✓
4218	ACT1 MINIMUM	-1000...1000%	1%	0%		
4219	ACT1 MAXIMUM	-1000...1000%	1%	100%		
4220	ACT2 MINIMUM	-1000...1000%	1%	0%		

Code	Name	Range	Resolution	Default	User	S
4221	ACT2 MAXIMUM	-1000...1000%	1%	100%		
4228	ACTIVATE	-6...12	1	0 (NOT SEL)		
4229	OFFSET	0.0...100.0%	0.1%	0.0%		
4230	TRIM MODE	0 = NOT SEL, 1 = PROPORTIONAL, 3 = DIRECT	1	0 (NOT SEL)		
4231	TRIM SCALE	-100.0...100.0%	0.1%	0.0%		
4232	CORRECTION SRC	1 = PID2REF, 2 = PID2OUTPUT	1	1 (PID2REF)		
Group 45: ENERGY SAVING						
4502	ENERGY PRICE	0.00...655.35	0.01	0.00		
4507	CO2 CONV FACTOR	0.0...10.0 tn/MWh	0.1 tn/MWh	0.5 tn/MWh		
4508	PUMP POWER	0.0...1000.0%	0.1%	100.0%		
4509	ENERGY RESET	0 = DONE, 1 = RESET	1	0 (DONE)		
Group 51: EXT COMM MODULE						
5101	FBA TYPE	-	-	0 (NOT DEFINED)		
5102... 5126	FB PAR 2...26	0...65535	1	0		
5127	FBA PAR REFRESH	0 = DONE, 1 = REFRESH	1	0 (DONE)		✓
5128	FILE CPI FW REV	0000...FFFF hex	1	0		
5129	FILE CONFIG ID	0000...FFFF hex	1	0		
5130	FILE CONFIG REV	0000...FFFF hex	1	0		
5131	FBA STATUS	0...6	1	0 (IDLE)		
5132	FBA CPI FW REV	0000...FFFF hex	1	0		
5133	FBA APPL FW REV	0000...FFFF hex	1	0		
Group 52: PANEL COMM						
5201	STATION ID	1...247	1	1		
5202	BAUD RATE	9.6, 19.2, 38.4, 57.6, 115.2 kbits/s	-	9.6 kbits/s		
5203	PARITY	0 = 8 NONE 1, 1 = 8 NONE 2, 2 = 8 EVEN 1, 3 = 8 ODD 1	1	0 (8 NONE 1)		
5204	OK MESSAGES	0...65535	1	-		
5205	PARITY ERRORS	0...65535	1	-		
5206	FRAME ERRORS	0...65535	1	-		
5207	BUFFER OVERRUNS	0...65535	1	-		
5208	CRC ERRORS	0...65535	1	-		
Group 53: EFB PROTOCOL						
5301	EFB PROTOCOL ID	0...0xFFFF	1	0		
5302	EFB STATION ID	0...65535	1	1		✓
5303	EFB BAUD RATE	1.2, 2.4, 4.8, 9.6, 19.2, 38.4, 57.6, 76.8 kbits/s	-	9.6 kbits/s		
5304	EFB PARITY	0 = 8 NONE 1, 1 = 8 NONE 2, 2 = 8 EVEN 1, 3 = 8 ODD 1		0 (8 NONE 1)		
5305	EFB CTRL PROFILE	0 = ABB DRV LIM, 1 = DCU PROFILE, 2 = ABB DRV FULL	1	0 (ABB DRV LIM)		
5306	EFB OK MESSAGES	0...65535	1	0		
5307	EFB CRC ERRORS	0...65535	1	0		
5308	EFB UART ERRORS	0...65535	1	0		
5309	EFB STATUS	0...7	1	0 (IDLE)		
5310	EFB PAR 10	0...65535	1	0		

Code	Name	Range	Resolution	Default	User	S
5311	EFB PAR 11	0...65535	1	0		
5312	EFB PAR 12	0...65535	1	0		
5313	EFB PAR 13	0...65535	1	0		
5314	EFB PAR 14	0...65535	1	0		
5315	EFB PAR 15	0...65535	1	0		
5316	EFB PAR 16	0...65535	1	0		
5317	EFB PAR 17	0...65535	1	0		
5318	EFB PAR 18	0...65535	1	0		
5319	EFB PAR 19	0000...FFFF hex	1	0		
5320	EFB PAR 20	0000...FFFF hex	1	0		
Group 64: LOAD ANALYZER						
6401	PVL SIGNAL	100...178	1	103 (parameter 0103 OUTPUT FREQ)		
6402	PVL FILTER TIME	0.0...120.0 s	0.1 s	0.1 s		
6403	LOGGERS RESET	-6...7	1	0 (NOT SEL)		
6404	AL2 SIGNAL	101...178	1	103 (parameter 0103 OUTPUT FREQ)		
6405	AL2 SIGNAL BASE	-	-	Depends on the signal selected with par. 6404.		
6406	PEAK VALUE	-	-	-		
6407	PEAK TIME 1	Date dd.mm.yy / power-on time in days	1 d	-		
6408	PEAK TIME 2	Time hh.mm.ss	2 s	-		
6409	CURRENT AT PEAK	0.0...6553.5 A	0.1 A	-		
6410	UDC AT PEAK	0...65535 V	1 V	-		
6411	FREQ AT PEAK	0.0...6553.5 Hz	0.1 Hz	-		
6412	TIME OF RESET 1	Date dd.mm.yy / power-on time in days	1 d	-		
6413	TIME OF RESET 2	Time hh.mm.ss	2 s	-		
6414	AL1RANGE0TO10	0.0...100.0%	0.1%	-		
6415	AL1RANGE10TO20	0.0...100.0%	0.1%	-		
6416	AL1RANGE20TO30	0.0...100.0%	0.1%	-		
6417	AL1RANGE30TO40	0.0...100.0%	0.1%	-		
6418	AL1RANGE40TO50	0.0...100.0%	0.1%	-		
6419	AL1RANGE50TO60	0.0...100.0%	0.1%	-		
6420	AL1RANGE60TO70	0.0...100.0%	0.1%	-		
6421	AL1RANGE70TO80	0.0...100.0%	0.1%	-		
6422	AL1RANGE80TO90	0.0...100.0%	0.1%	-		
6423	AL1RANGE90TO	0.0...100.0%	0.1%	-		
6424	AL2RANGE0TO10	0.0...100.0%	0.1%	-		
6425	AL2RANGE10TO20	0.0...100.0%	0.1%	-		
6426	AL2RANGE20TO30	0.0...100.0%	0.1%	-		
6427	AL2RANGE30TO40	0.0...100.0%	0.1%	-		
6428	AL2RANGE40TO50	0.0...100.0%	0.1%	-		
6429	AL2RANGE50TO60	0.0...100.0%	0.1%	-		
6430	AL2RANGE60TO70	0.0...100.0%	0.1%	-		
6431	AL2RANGE70TO80	0.0...100.0%	0.1%	-		
6432	AL2RANGE80TO90	0.0...100.0%	0.1%	-		

Code	Name	Range	Resolution	Default	User	S
6433	AL2RANGE90TO	0.0...100.0%	0.1%	-		
Group 81: PFC CONTROL						
8103	REFERENCE STEP 1	0.0...100.0%	0.1%	0.0%		
8104	REFERENCE STEP 2	0.0...100.0%	0.1%	0.0%		
8105	REFERENCE STEP 3	0.0...100.0%	0.1%	0.0%		
8109	START FREQ 1	0.0...500.0 Hz	0.1 Hz	-U1: 60.0 Hz		
8110	START FREQ 2	0.0...500.0 Hz	0.1 Hz	-U1: 60.0 Hz		
8111	START FREQ 3	0.0...500.0 Hz	0.1 Hz	-U1: 60.0 Hz		
8112	LOW FREQ 1	0.0...500.0 Hz	0.1 Hz	-U1: 30.0 Hz		
8113	LOW FREQ 2	0.0...500.0 Hz	0.1 Hz	-U1: 30.0 Hz		
8114	LOW FREQ 3	0.0...500.0 Hz	0.1 Hz	-U1: 30.0 Hz		
8115	AUX MOT START D	0.0...3600.0 s	0.1 s	5.0 s		
8116	AUX MOT STOP D	0.0...3600.0 s	0.1 s	3.0 s		
8117	NR OF AUX MOT	0...4	1	1		✓
8118	AUTOCHNG INTERV	-0.1 = TEST MODE, 0.0 = NOT SEL, 0.1...336.0 h	0.1 h	0.0 h (NOT SEL)		✓
8119	AUTOCHNG LEVEL	0.0...100.0%	0.1%	50.0%		
8120	INTERLOCKS	0...6	1	4 (DI4)		✓
8121	REG BYPASS CTRL	0 = NO, 1 = YES	1	0 (NO)		
8122	PFC START DELAY	0.00...10.00 s	0.01 s	0.50 s		
8123	PFC ENABLE	0 = NOT SEL, 1 = ACTIVE	1	0 (NOT SEL)		✓
8124	ACC IN AUX STOP	0.0 = NOT SEL, 0.1...1800.0 s	0.1 s	0.0 s (NOT SEL)		
8125	DEC IN AUX START	0.0 = NOT SEL, 0.1...1800.0 s	0.1 s	0.0 s (NOT SEL)		
8126	TMED AUTOCHNG	0...4	1	0 (NOT SEL)		
8127	MOTORS	1...7	1	2		✓
8128	AUX START ORDER	1 = EVEN RUNTIME, 2 = RELAY ORDER	1	1 (EVEN RUNTIME)		✓
Group 98: OPTIONS						
9802	COMM PROT SEL	0 = NOT SEL, 1 = STD MODBUS, 4 = EXT FBA, 5 = BACNET	1	0 (NOT SEL)		✓

Complete parameter descriptions

This section describes the actual signals and parameters for ACQ550.

Group 99: START-UP DATA

This group defines special start-up data required to:

- set up the drive
- enter motor information.

Code	Description																				
9901	<p>LANGUAGE</p> <p>Selects the display language.</p> <p>ACQ Control Panel ACQ-CP-AQ:</p> <table> <tr> <td>0 = ENGLISH</td> <td>1 = ENGLISH (AM)</td> <td>2 = DEUTSCH</td> <td>3 = ITALIANO</td> <td>4 = ESPAÑOL</td> </tr> <tr> <td>5 = PORTUGUES</td> <td>6 = NEDERLANDS</td> <td>7 = FRANÇAIS</td> <td>8 = DANSK</td> <td>9 = SUOMI</td> </tr> <tr> <td>10 = SVENSKA</td> <td>11 = RUSSKI</td> <td>12 = POLSKI</td> <td>13 = TÜRKÇE</td> <td>14 = CZECH</td> </tr> <tr> <td>15 = MAGYAR</td> <td>16 = ELLINIKA</td> <td>17 = CHINESE</td> <td>18 = KOREAN</td> <td>19 = JAPANESE</td> </tr> </table>	0 = ENGLISH	1 = ENGLISH (AM)	2 = DEUTSCH	3 = ITALIANO	4 = ESPAÑOL	5 = PORTUGUES	6 = NEDERLANDS	7 = FRANÇAIS	8 = DANSK	9 = SUOMI	10 = SVENSKA	11 = RUSSKI	12 = POLSKI	13 = TÜRKÇE	14 = CZECH	15 = MAGYAR	16 = ELLINIKA	17 = CHINESE	18 = KOREAN	19 = JAPANESE
0 = ENGLISH	1 = ENGLISH (AM)	2 = DEUTSCH	3 = ITALIANO	4 = ESPAÑOL																	
5 = PORTUGUES	6 = NEDERLANDS	7 = FRANÇAIS	8 = DANSK	9 = SUOMI																	
10 = SVENSKA	11 = RUSSKI	12 = POLSKI	13 = TÜRKÇE	14 = CZECH																	
15 = MAGYAR	16 = ELLINIKA	17 = CHINESE	18 = KOREAN	19 = JAPANESE																	
9902	<p>APPLIC MACRO</p> <p>Selects an application macro. Application macros automatically edit parameters to configure the ACQ550 for a particular application.</p> <table> <tr> <td>1 = ABB 2-WIRE</td> <td>2 = 3-WIRE</td> <td>3 = ALTERNATE</td> <td>4 = MOTOR POT</td> <td>5 = HAND/AUTO</td> </tr> <tr> <td>6 = PID CONTROL</td> <td>7 = PFC CONTROL</td> <td></td> <td></td> <td></td> </tr> <tr> <td>0 = USER S1 LOAD</td> <td>-1 = USER S1 SAVE</td> <td>-2 = USER S2 LOAD</td> <td>-3 = USER S2 SAVE</td> <td></td> </tr> </table> <p>-1 = USER S1 SAVE, -3 = USER S2 SAVE – With these it is possible to save two different user parameter sets into the drive permanent memory for later use. Each set contains parameter settings, including Group 99: START-UP DATA, and the results of the motor identification run.</p> <p>0 = USER S1 LOAD, -2 = USER S2 LOAD – With these the user parameter sets can be taken back in use.</p>	1 = ABB 2-WIRE	2 = 3-WIRE	3 = ALTERNATE	4 = MOTOR POT	5 = HAND/AUTO	6 = PID CONTROL	7 = PFC CONTROL				0 = USER S1 LOAD	-1 = USER S1 SAVE	-2 = USER S2 LOAD	-3 = USER S2 SAVE						
1 = ABB 2-WIRE	2 = 3-WIRE	3 = ALTERNATE	4 = MOTOR POT	5 = HAND/AUTO																	
6 = PID CONTROL	7 = PFC CONTROL																				
0 = USER S1 LOAD	-1 = USER S1 SAVE	-2 = USER S2 LOAD	-3 = USER S2 SAVE																		
9904	<p>MOTOR CTRL MODE</p> <p>Selects the motor control mode.</p> <p>1 or 2 = VECTOR:SPEED – sensorless vector control mode.</p> <ul style="list-style-type: none"> • Reference 1 is speed reference in rpm. • Reference 2 is speed reference in % (100% is absolute maximum speed, equal to the value of parameter 2002 MAXIMUM SPEED, or 2001 MINIMUM SPEED if the absolute value of the minimum speed is greater than the maximum speed). <p>3 = SCALAR:FREQ – scalar control mode – Default</p> <ul style="list-style-type: none"> • Reference 1 is frequency reference in Hz. • Reference 2 is frequency reference in % (100% is absolute maximum frequency, equal to the value of parameter 2008 MAXIMUM FREQ, or 2007 MINIMUM FREQ if the absolute value of the minimum speed is greater than the maximum speed). 																				
9905	<p>MOTOR NOM VOLT</p> <p>Defines the nominal motor voltage.</p> <ul style="list-style-type: none"> • Must equal the value on the motor rating plate. • The ACQ550 cannot supply the motor with a voltage greater than the input power (mains) voltage. 																				
9906	<p>MOTOR NOM CURR</p> <p>Defines the nominal motor current.</p> <ul style="list-style-type: none"> • Must equal the value on the motor rating plate. • Range allowed: 0.2...2.0 · I_{2hd} (where I_{2hd} is drive current). 																				
9907	<p>MOTOR NOM FREQ</p> <p>Defines the nominal motor frequency.</p> <ul style="list-style-type: none"> • Range: 10...500 Hz (typically 50 or 60 Hz) • Sets the frequency at which output voltage equals the MOTOR NOM VOLT. • Field weakening point = Nom Freq · Supply Volt / Mot Nom Volt 																				

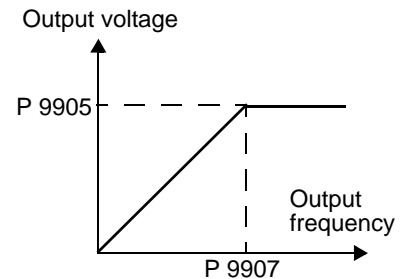

Code	Description
9908	<p>MOTOR NOM SPEED</p> <p>Defines the nominal motor speed.</p> <ul style="list-style-type: none"> • Must equal the value on the motor rating plate.
9909	<p>MOTOR NOM POWER</p> <p>Defines the nominal motor power.</p> <ul style="list-style-type: none"> • Must equal the value on the motor rating plate.
9910	<p>ID RUN</p> <p>This parameter controls a self-calibration process called the Motor ID Run. During this process, the drive operates the motor (motor rotating) and makes measurements in order to identify motor characteristics and create a model used for internal calculations. An ID Run is especially effective when:</p> <ul style="list-style-type: none"> • vector control mode is used [parameter 9904 = 1 or 2 (VECTOR:SPEED) and/or • operation point is near zero speed, and/or • operation requires a torque range above the motor nominal torque, over a wide speed range, and without any measured speed feedback (i.e. without a pulse encoder). <p>0 = OFF/IDMAGN – The Motor ID Run process is not run. Identification magnetization is performed, depending on parameter 9904 and 2101 settings. In identification magnetization, the motor model is calculated at first start by magnetizing the motor for 10 to 15 s at zero speed (motor not rotating). The model is recalculated always at start after motor parameter changes.</p> <ul style="list-style-type: none"> • Parameter 9904 = 1 or 2 (VECTOR:SPEED): Identification magnetization is performed. • Parameter 9904 = 3 (SCALAR:FREQ) and parameter 2101 = 3 (SCALAR FLYST) or 5 (FLY + BOOST): Identification magnetization is performed. • Parameter 9904 = 3 (SCALAR:FREQ) and parameter 2101 has other value than 3 (SCALAR FLYST) or 5 (FLY + BOOST): Identification magnetization is not performed. <p>1 = ON – Enables the Motor ID Run, during which the motor is rotating, at the next start command. After run completion, this value automatically changes to 0.</p> <p>Note: The motor must be de-coupled from the driven equipment.</p> <p>Note: If motor parameters are changed after ID Run, repeat the ID Run.</p> <p> WARNING! The motor will run at up to approximately 50...80% of the nominal speed during the ID Run. The motor will rotate in the forward direction.</p> <p>Ensure that it is safe to run the motor before performing the ID Run!</p> <p>See also section How to perform the ID Run on page 40.</p>
9915	<p>MOTOR COSPHI</p> <p>Defines the nominal motor cos phi (power factor). The parameter improves performance especially with high efficiency motors.</p> <p>0 = IDENTIFIED – Drive identifies the cos phi automatically by estimation.</p> <p>0.01...0.97 – Value entered used as the cos phi.</p>

Group 01: OPERATING DATA

This group contains drive operating data, including actual signals. The drive sets the values for actual signals, based on measurements or calculations. You cannot set these values.

Code	Description
0101	SPEED & DIR The calculated signed speed of the motor (rpm). The absolute value of 0101 SPEED & DIR is the same as the value of 0102 SPEED. <ul style="list-style-type: none"> • The value of 0101 SPEED & DIR is positive if the motor runs in the forward direction. • The value of 0101 SPEED & DIR is negative if the motor runs in the reverse direction.
0102	SPEED The calculated speed of the motor (rpm). (Parameter 0102 or 0103 is shown by default in the control panel Output mode.)
0103	OUTPUT FREQ The frequency (Hz) applied to the motor. (Parameter 0102 or 0103 is shown by default in the control panel Output mode.)
0104	CURRENT The motor current, as measured by the ACQ550. (Shown by default in the control panel Output mode.)
0105	TORQUE Output torque. Calculated value of torque on motor shaft in % of motor nominal torque. (Shown by default in the control panel Output mode.)
0106	POWER The measured motor power in kW.
0107	DC BUS VOLTAGE The DC bus voltage in V DC, as measured by the ACQ550.
0109	OUTPUT VOLTAGE The voltage applied to the motor.
0110	DRIVE TEMP The temperature of the drive power transistors in degrees Celsius.
0111	EXTERNAL REF 1 External reference, REF1, in rpm or Hz – units determined by parameter 9904.
0112	EXTERNAL REF 2 External reference, REF2, in %.
0113	CTRL LOCATION Active control location. Alternatives are: 0 = LOCAL 1 = EXT1 2 = EXT2
0114	RUN TIME (R) The drive's accumulated running time in hours (h). <ul style="list-style-type: none"> • Can be reset by pressing UP and DOWN keys simultaneously when the control panel is in the Parameters mode.
0115	KWH COUNTER (R) The drive's accumulated power consumption in kilowatt hours. <ul style="list-style-type: none"> • The counter value is accumulated till it reaches 65535 after which the counter rolls over and starts again from 0. • Can be reset by pressing UP and DOWN keys simultaneously when the control panel is in the Parameters mode.
0116	APPL BLK OUTPUT Application block output signal. Value is from either: <ul style="list-style-type: none"> • PFC control, if PFC Control is active, or • Parameter 0112 EXTERNAL REF 2.

Code	Description	
0118	DI 1-3 STATUS Status of the three digital inputs. <ul style="list-style-type: none"> • Status is displayed as a binary number. • 1 indicates that the input is activated. • 0 indicates that the input is deactivated. 	
0119	DI 4-6 STATUS Status of the three digital inputs. <ul style="list-style-type: none"> • See parameter 0118 DI 1-3 STATUS. 	
0120	AI 1 The relative value of analog input 1 in %.	
0121	AI 2 The relative value of analog input 2 in %.	
0122	RO 1-3 STATUS Status of the three relay outputs. <ul style="list-style-type: none"> • 1 indicates that the relay is energized. • 0 indicates that the relay is de-energized. 	
0123	RO 4-6 STATUS Status of the three relay outputs. Available if OREL-01 Relay Output Extension Module is installed. <ul style="list-style-type: none"> • See parameter 0122. 	
0124	AO 1 The analog output 1 value in milliamperes.	
0125	AO 2 The analog output 2 value in milliamperes.	
0126	PID 1 OUTPUT The PID controller 1 output value in %.	
0127	PID 2 OUTPUT The PID controller 2 output value in %.	
0128	PID 1 SETPNT The PID 1 controller setpoint signal. <ul style="list-style-type: none"> • Units and scale defined by PID parameters. 	
0129	PID 2 SETPNT The PID 2 controller setpoint signal. <ul style="list-style-type: none"> • Units and scale defined by PID parameters. 	
0130	PID 1 FBK The PID 1 controller feedback signal. <ul style="list-style-type: none"> • Units and scale defined by PID parameters. 	
0131	PID 2 FBK The PID 2 controller feedback signal. <ul style="list-style-type: none"> • Units and scale defined by PID parameters. 	
0132	PID 1 DEVIATION The difference between the PID 1 controller reference value and actual value. <ul style="list-style-type: none"> • Units and scale defined by PID parameters. 	
0133	PID 2 DEVIATION The difference between the PID 2 controller reference value and actual value. <ul style="list-style-type: none"> • Units and scale defined by PID parameters. 	
0134	COMM RO WORD Free data location that can be written from serial link. <ul style="list-style-type: none"> • Used for relay output control. • See parameter 1401. 	
0135	COMM VALUE 1 Free data location that can be written from serial link.	

Code	Description
0136	COMM VALUE 2 Free data location that can be written from serial link.
0137	PROCESS VAR 1 Process variable 1 <ul style="list-style-type: none"> Defined by parameters in Group 34: PANEL DISPLAY.
0138	PROCESS VAR 2 Process variable 2 <ul style="list-style-type: none"> Defined by parameters in Group 34: PANEL DISPLAY.
0139	PROCESS VAR 3 Process variable 3 <ul style="list-style-type: none"> Defined by parameters in Group 34: PANEL DISPLAY.
0140	RUN TIME The drive's accumulated running time in thousands of hours (kh). <ul style="list-style-type: none"> Cannot be reset.
0141	MWH COUNTER The drive's accumulated power consumption in megawatt hours. <ul style="list-style-type: none"> The counter value is accumulated till it reaches 65535 after which the counter rolls over and starts again from 0. Cannot be reset.
0142	REVOLUTION CNTR The motor's accumulated revolutions in millions of revolutions. <ul style="list-style-type: none"> Can be reset by pressing UP and DOWN keys simultaneously when the control panel is in the Parameters mode.
0143	DRIVE ON TIME HI The drive's accumulated power-on time in days. <ul style="list-style-type: none"> Cannot be reset.
0144	DRIVE ON TIME LO The drive's accumulated power-on time in 2 second ticks (30 ticks = 60 seconds). <ul style="list-style-type: none"> Shown in format hh.mm.ss. Cannot be reset.
0145	MOTOR TEMP Motor temperature in degrees Celsius / PTC resistance in ohms. <ul style="list-style-type: none"> Applies only if motor temperature sensor is set up. See parameter 3501.
0150	CB TEMP Temperature of the drive control board in degrees Celsius.
0153	MOT THERM STRESS Estimated rise of the motor temperature. Value equals to the estimated motor thermal stress as a percentage of the motor temperature trip level.
0158	PID COMM VALUE 1 Data received from fieldbus for PID control (PID1 and PID2).
0159	PID COMM VALUE 2 Data received from fieldbus for PID control (PID1 and PID2).
0174	SAVED KWH Energy saved in kWh compared to the energy used when the pump is connected directly to the supply. See the note on page 156 . <ul style="list-style-type: none"> The counter value is accumulated till it reaches 999.9 after which the counter rolls over and starts again from 0.0. Can be reset with parameter 4509 ENERGY RESET (resets all energy calculators at the same time). See Group 45: ENERGY SAVING.
0175	SAVED MWH Energy saved in MWh compared to the energy used when the pump is connected directly to the supply. See the note on page 156 . <ul style="list-style-type: none"> The counter value is accumulated till it reaches 65535 after which the counter rolls over and starts again from 0. Can be reset with parameter 4509 ENERGY RESET (resets all energy calculators at the same time). See Group 45: ENERGY SAVING.

Code	Description
0176	<p>SAVED AMOUNT 1</p> <p>Energy saved in local currency (remainder when the total saved energy is divided by 1000). See the note on page 156.</p> <ul style="list-style-type: none"> To find out the total saved energy in currency units, add the value of parameter 0177 multiplied by 1000 to the value of parameter 0176. <p>Example:</p> <p>0176 SAVED AMOUNT 1 = 123.4 0177 SAVED AMOUNT 2 = 5 Total saved energy = 5 · 1000 + 123.4 = 5123.4 currency units.</p> <ul style="list-style-type: none"> The counter value is accumulated till it reaches 999.9 (the counter does not roll over). Can be reset with parameter 4509 ENERGY RESET (resets all energy calculators at the same time). Local energy price is set with parameter 4502 ENERGY PRICE. See Group 45: ENERGY SAVING.
0177	<p>SAVED AMOUNT 2</p> <p>Energy saved in local currency in thousand currency units. Eg value 5 means 5000 currency units. See the note on page 156.</p> <ul style="list-style-type: none"> The counter value is accumulated till it reaches 65535 (the counter does not roll over). See parameter 0176 SAVED AMOUNT 1.
0178	<p>SAVED CO2</p> <p>Reduction on carbon dioxide emissions in tn. See the note on page 156.</p> <ul style="list-style-type: none"> The counter value is accumulated till it reaches 6553.5 (the counter does not roll over). Can be reset with parameter 4509 ENERGY RESET (resets all energy calculators at the same time). CO2 conversion factor is set with parameter 4507 CO2 CONV FACTOR. See Group 45: ENERGY SAVING.

Group 03: FB ACTUAL SIGNALS

This group monitors fieldbus communications.

Code	Description					
0301	FB CMD WORD 1 Read-only copy of the Fieldbus Command Word 1. <ul style="list-style-type: none"> The fieldbus command is the principal means for controlling the drive from a fieldbus controller. The command consists of two Command Words. Bit-coded instructions in the Command Words switch the drive between states. To control the drive, using the Command Words, an external location (EXT1 or EXT2) must be active and set to COMM. (See parameters 1001 and 1002.) The control panel displays the word in hex. For example, all zeros and a 1 in Bit 0 displays as 0001. All zeros and a 1 in Bit 15 displays as 8000. 	Bit #	0301, FB CMD WORD 1	0302, FB CMD WORD 2		
		0	STOP	FBLOCAL_CTL		
		1	START	FBLOCAL_REF		
		2	REVERSE	START_DISABLE1		
		3	LOCAL	START_DISABLE2		
		4	RESET	Reserved		
		5	EXT2	Reserved		
		6	RUN_DISABLE	Reserved		
		7	STPMODE_R	Reserved		
		8	STPMODE_EM	Reserved		
		9	STPMODE_C	Reserved		
		10	RAMP_2	Reserved		
		11	RAMP_OUT_0	REF_CONST		
		12	RAMP_HOLD	REF_AVE		
		13	RAMP_IN_0	LINK_ON		
0302	FB CMD WORD 2 Read-only copy of the Fieldbus Command Word 2. <ul style="list-style-type: none"> See parameter 0301. 	14	RREQ_LOCALLOC	REQ_STARTINH		
		15	TORQLIM2	OFF_INTERLOCK		
		0303	FB STS WORD 1 Read-only copy of the Status Word 1. <ul style="list-style-type: none"> The drive sends status information to the fieldbus controller. The status consists of two Status Words. The control panel displays the word in hex. For example, all zeros and a 1 in Bit 0 displays as 0001. All zeros and a 1 in Bit 15 displays as 8000. 	Bit #	0303, FB STS WORD 1	0304, FB STS WORD 2
				0	READY	ALARM
				1	ENABLED	NOTICE
				2	STARTED	DIRLOCK
				3	RUNNING	LOCALLOCK
				4	ZERO_SPEED	CTL_MODE
				5	ACCELERATE	Reserved
				6	DECELERATE	Reserved
				7	AT_SETPOINT	CPY_CTL
				8	LIMIT	CPY_REF1
				9	SUPERVISION	CPY_REF2
				10	REV_REF	REQ_CTL
				11	REV_ACT	REQ_REF1
12	PANEL_LOCAL			REQ_REF2		
0304	FB STS WORD 2 Read-only copy of the Status Word 2. <ul style="list-style-type: none"> See parameter 0303. 			13	FIELDBUS_LOCAL	REQ_REF2EXT
		14	EXT2_ACT	ACK_STARTINH		
		15	FAULT	ACK_OFF_ILCK		

Code	Description				
0305	FAULT WORD 1 Read-only copy of the Fault Word 1. <ul style="list-style-type: none"> When a fault is active, the corresponding bit for the active fault is set in the Fault Words. Each fault has a dedicated bit allocated within Fault Words. See section Fault listing on page 252 for a description of the faults. The control panel displays the word in hex. For example, all zeros and a 1 in Bit 0 displays as 0001. All zeros and a 1 in Bit 15 displays as 8000. 	Bit #	0305, FAULT WORD 1	0306, FAULT WORD 2	0307, FAULT WORD 3
		0	OVERCURRENT	Obsolete	EFB 1
		1	DC OVERVOLT	THERM FAIL	EFB 2
		2	DEV OVERTEMP	OPEX LINK	EFB 3
		3	SHORT CIRC	OPEX PWR	INCOMPATIBLE SW
		4	Reserved	CURR MEAS	USER LOAD CURVE
		5	DC UNDERVOLT	SUPPLY PHASE	Reserved
		6	AI1 LOSS	ENCODER ERR	Reserved
		7	AI2 LOSS	OVERSPEED	Reserved
		8	MOT OVERTEMP	Reserved	Reserved
		9	PANEL LOSS	DRIVE ID	Reserved
		10	ID RUN FAIL	CONFIG FILE	System error
		11	MOTOR STALL	SERIAL 1 ERR	System error
		12	CB OVERTEMP	EFB CON FILE	System error
		13	EXT FAULT 1	FORCE TRIP	System error
14	EXT FAULT 2	MOTOR PHASE	System error		
15	EARTH FAULT	OUTP WIRING	Param. setting fault		
0306	FAULT WORD 2 Read-only copy of the Fault Word 2. <ul style="list-style-type: none"> See parameter 0305. 				
0307	FAULT WORD 3 Read-only copy of the Fault Word 3. <ul style="list-style-type: none"> See parameter 0305. 				
		0308	ALARM WORD 1 <ul style="list-style-type: none"> When an alarm is active, the corresponding bit for the active alarm is set in the Alarm Words. Each alarm has a dedicated bit allocated within Alarm Words. Bits remain set until the whole alarm word is reset. (Reset by writing zero to the word.) The control panel displays the word in hex. For example, all zeros and a 1 in Bit 0 displays as 0001. All zeros and a 1 in Bit 15 displays as 8000. 	Bit #	0308, ALARM WORD 1
0	OVERCURRENT			Reserved	
1	OVERVOLTAGE			PID SLEEP	
2	UNDERVOLTAGE			ID RUN	
3	DIR LOCK			Reserved	
4	IO COMM			START ENABLE 1 MISSING	
5	AI1 LOSS			START ENABLE 2 MISSING	
6	AI2 LOSS			EMERGENCY STOP	
7	PANEL LOSS			ENCODER ERROR	
8	DEVICE OVERTEMP			FIRST START	
9	MOTOR TEMP			Reserved	
10	Reserved			USER LOAD CURVE	
11	MOTOR STALL			START DELAY	
12	AUTORESET			Reserved	
13	AUTOCHANGE			Reserved	
14	PFC I LOCK	Reserved			
15	Reserved	Reserved			
0309	ALARM WORD 2 See parameter 0308.				

Group 04: FAULT HISTORY

This group stores a recent history of the faults reported by the drive.

Code	Description
0401	LAST FAULT 0 – Clear the fault history (on panel = NO RECORD). n – Fault code of the last recorded fault. The fault code is displayed as a name. See section Fault listing on page 252 for the fault codes and names. The fault name shown for this parameter may be shorter than the corresponding name in the fault listing, which shows the names as they are shown in the fault display.
0402	FAULT TIME 1 The day on which the last fault occurred. Either as: <ul style="list-style-type: none"> • A date – if real time clock is operating. • The number of days after power on – if real time clock is not used, or was not set.
0403	FAULT TIME 2 The time at which the last fault occurred. Either as: <ul style="list-style-type: none"> • Real time, in format hh:mm:ss – if real time clock is operating. • The time since power on (minus the whole days reported in 0402), in format hh:mm:ss – if real time clock is not used, or was not set.
0404	SPEED AT FLT The motor speed (rpm) at the time the last fault occurred.
0405	FREQ AT FLT The frequency (Hz) at the time the last fault occurred.
0406	VOLTAGE AT FLT The DC bus voltage (V) at the time the last fault occurred.
0407	CURRENT AT FLT The motor current (A) at the time the last fault occurred.
0408	TORQUE AT FLT The motor torque (%) at the time the last fault occurred.
0409	STATUS AT FLT The drive status (hex code word) at the time the last fault occurred.
0410	DI 1-3 AT FLT The status of digital inputs 1...3 at the time the last fault occurred.
0411	DI 4-6 AT FLT The status of digital inputs 4...6 at the time the last fault occurred.
0412	PREVIOUS FAULT 1 Fault code of the second last fault. Read-only.
0413	PREVIOUS FAULT 2 Fault code of the third last fault. Read-only.

Group 10: START/STOP/DIR

This group:

- defines external sources (EXT1 and EXT2) for commands that enable start, stop and direction changes
- locks direction or enables direction control.

To select between the two external locations use the next group (parameter 1102).

Code	Description
1001	<p>EXT1 COMMANDS</p> <p>Defines external control location 1 (EXT1) – the configuration of start, stop and direction commands.</p> <p>0 = NOT SEL – No external start, stop and direction command source.</p> <p>1 = DI1 – Two-wire Start/Stop.</p> <ul style="list-style-type: none"> • Start/Stop is through digital input DI1 (DI1 activated = Start; DI1 de-activated = Stop). • Parameter 1003 defines the direction. Selecting 1003 = 3 (REQUEST) is the same as 1003 = 1 (FORWARD). <p>2 = DI1,2 – Two-wire Start/Stop, Direction.</p> <ul style="list-style-type: none"> • Start/Stop is through digital input DI1 (DI1 activated = Start; DI1 de-activated = Stop). • Direction control [requires parameter 1003 = 3 (REQUEST)] is through digital input DI2 (DI2 activated = Reverse; de-activated = Forward). <p>3 = DI1P,2P – Three-wire Start/Stop.</p> <ul style="list-style-type: none"> • Start/Stop commands are through momentary push-buttons (the P stands for “pulse”). • Start is through a normally open push-button connected to digital input DI1. In order to start the drive, the digital input DI2 must be activated prior to the pulse in DI1. • Connect multiple Start push-buttons in parallel. • Stop is through a normally closed push-button connected to digital input DI2. • Connect multiple Stop push-buttons in series. • Parameter 1003 defines the direction. Selecting 1003 = 3 (REQUEST) is the same as 1003 = 1 (FORWARD). <p>4 = DI1P,2P,3 – Three-wire Start/Stop, Direction.</p> <ul style="list-style-type: none"> • Start/Stop commands are through momentary push-buttons, as described for DI1P,2P. • Direction control [requires parameter 1003 = 3 (REQUEST)] is through digital input DI3 (DI3 activated = Reverse; de-activated = Forward). <p>5 = DI1P,2P,3P – Start Forward, Start Reverse and Stop.</p> <ul style="list-style-type: none"> • Start and Direction commands are given simultaneously with two separate momentary push-buttons (the P stands for “pulse”). • Start Forward command is through a normally open push-button connected to digital input DI1. In order to start the drive, the digital input DI3 must be activated prior to the pulse in DI1. • Start Reverse command is through a normally open push-button connected to digital input DI2. In order to start the drive, the digital input DI3 must be activated during the pulse in DI2. • Connect multiple Start push-buttons in parallel. • Stop is through a normally closed push-button connected to digital input DI3. • Connect multiple Stop push-buttons in series. • Requires parameter 1003 = 3 (REQUEST). <p>6 = DI6 – Two-wire Start/Stop.</p> <ul style="list-style-type: none"> • Start/Stop is through digital input DI6 (DI6 activated = Start; DI6 de-activated = Stop). • Parameter 1003 defines the direction. Selecting 1003 = 3 (REQUEST) is the same as 1003 = 1 (FORWARD). <p>7 = DI6,5 – Two-wire Start/Stop/Direction.</p> <ul style="list-style-type: none"> • Start/Stop is through digital input DI6 (DI6 activated = Start; DI6 de-activated = Stop). • Direction control [requires parameter 1003 = 3 (REQUEST)] is through digital input DI5 (DI5 activated = Reverse; de-activated = Forward). <p>8 = KEYPAD – Control Panel.</p> <ul style="list-style-type: none"> • Start/Stop and Direction commands are through the control panel when EXT1 is active. • Direction control requires parameter 1003 = 3 (REQUEST). <p>9 = DI1F,2R – Start/Stop/Direction commands through DI1 and DI2 combinations.</p> <ul style="list-style-type: none"> • Start forward = DI1 activated and DI2 de-activated. • Start reverse = DI1 de-activated and DI2 activated. • Stop = both DI1 and DI2 activated, or both de-activated. • Requires parameter 1003 = 3 (REQUEST). <p>10 = COMM – Assigns the fieldbus Command Word as the source for the start/stop and direction commands.</p> <ul style="list-style-type: none"> • Bits 0,1, 2 of Command Word 1 (parameter 0301) activates the start/stop and direction commands. • See Fieldbus user's manual for detailed instructions.

Code	Description
	11 = TIMED FUNC 1. – Assigns Start/Stop control to Timed Function 1 (Timed Function activated = START; Timed Function de-activated = STOP). See Group 36: TIMED FUNCTIONS . 12...14 = TIMED FUNC 2...4 – Assigns Start/Stop control to Timed Function 2...4. See TIMED FUNC 1 above.
1002	EXT2 COMMANDS Defines external control location 2 (EXT2) – the configuration of start, stop and direction commands. • See parameter 1001 EXT1 COMMANDS above.
1003	DIRECTION Defines the control of motor rotation direction. 1 = FORWARD – Rotation is fixed in the forward direction. 2 = REVERSE – Rotation is fixed in the reverse direction. 3 = REQUEST – Rotation direction can be changed on command.
1004	JOGGING SEL Defines the signal that activates the jogging function. Jogging uses Constant Speed 7 (parameter 1208) for speed reference and ramp pair 2 (parameters 2205 and 2206) for accelerating and decelerating. When the jogging activation signal is lost, the drive uses ramp stop to decelerate to zero speed, even if coast stop is used in normal operation (parameter 2102). The jogging status can be parameterized to relay outputs (parameter 1401). The jogging status is also seen in DCU Profile status bit 21. 0 = NOT SEL – Disables the jogging function. 1 = DI1 – Activates/de-activates jogging based on the state of DI1 (DI1 activated = jogging active; DI1 de-activated = jogging inactive). 2...6 = DI2...DI6 – Activates jogging based on the state of the selected digital input. See DI1 above. -1 = DI1(INV) – Activates jogging based on the state of DI1 (DI1 activated = jogging inactive; DI1 de-activated = jogging active). -2...-6 = DI2(INV)...DI6(INV) – Activates jogging based on the state of the selected digital input. See DI1(INV) above.

Group 11: REFERENCE SELECT

This group defines:

- how the drive selects between command sources
- characteristics and sources for REF1 and REF2.

Code	Description
1101	<p>KEYPAD REF SEL</p> <p>Selects the reference controlled in local control mode.</p> <p>1 = REF1(Hz/rpm) – Reference type depends on parameter 9904 MOTOR CTRL MODE.</p> <ul style="list-style-type: none"> • Speed reference (rpm) if 9904 = 1 or 2 (VECTOR:SPEED). • Frequency reference (Hz) if 9904 = 3 (SCALAR:FREQ). <p>2 = REF2(%)</p>
1102	<p>EXT1/EXT2 SEL</p> <p>Defines the source for selecting between the two external control locations EXT1 or EXT2. Thus, defines the source for Start/Stop/Direction commands and reference signals.</p> <p>0 = EXT1 – Selects external control location 1 (EXT1).</p> <ul style="list-style-type: none"> • See parameter 1001 EXT1 COMMANDS for EXT1's Start/Stop/Dir definitions. • See parameter 1103 REF1 SELECT for EXT1's reference definitions. <p>1 = DI1 – Assigns control to EXT1 or EXT2 based on the state of DI1 (DI1 activated = EXT2; DI1 de-activated = EXT1).</p> <p>2...6 = DI2...DI6 – Assigns control to EXT1 or EXT2 based on the state of the selected digital input. See DI1 above.</p> <p>7 = EXT2 – Selects external control location 2 (EXT2).</p> <ul style="list-style-type: none"> • See parameter 1002 EXT2 COMMANDS for EXT2's Start/Stop/Dir definitions. • See parameter 1106 REF2 SELECT for EXT2's reference definitions. <p>8 = COMM – Assigns control of the drive via external control location EXT1 or EXT2 based on the fieldbus control word.</p> <ul style="list-style-type: none"> • Bit 5 of the Command Word 1 (parameter 0301) defines the active external control location (EXT1 or EXT2). • See Fieldbus user's manual for detailed instructions. <p>9 = TIMED FUNC 1 – Assigns control to EXT1 or EXT2 based on the state of the Timed Function (Timed Function activated = EXT2; Timed Function de-activated = EXT1). See Group 36: TIMED FUNCTIONS.</p> <p>10...12 = TIMED FUNC 2...4 – Assigns control to EXT1 or EXT2 based on the state of the Timed Function. See TIMED FUNC 1 above.</p> <p>-1 = DI1(INV) – Assigns control to EXT1 or EXT2 based on the state of DI1 (DI1 activated = EXT1; DI1 de-activated = EXT2).</p> <p>-2...-6 = DI2(INV)...DI6(INV) – Assigns control to EXT1 or EXT2 based on the state of the selected digital input. See DI1(INV) above.</p>
1103	<p>REF1 SELECT</p> <p>Selects the signal source for external reference REF1.</p> <p>0 = KEYPAD – Defines the control panel as the reference source.</p> <p>1 = AI1 – Defines analog input 1 (AI1) as the reference source.</p> <p>2 = AI2 – Defines analog input 2 (AI2) as the reference source.</p> <p>3 = AI1/JOYST – Defines analog input 1 (AI1), configured for joystick operation, as the reference source.</p> <ul style="list-style-type: none"> • The minimum input signal runs the drive at the maximum reference in the reverse direction. Define the minimum using parameter 1104. • The maximum input signal runs the drive at maximum reference in the forward direction. Define the maximum using parameter 1105. • Requires parameter 1003 = 3 (REQUEST). <p>⚠ WARNING! Because the low end of the reference range commands full reverse operation, do not use 0 V as the lower end of the reference range. Doing so means that if the control signal is lost (which is a 0 V input) the result is full reverse operation. Instead, use the following set-up so that loss of the analog input triggers a fault, stopping the drive:</p> <ul style="list-style-type: none"> • Set parameter 1301 MINIMUM AI1 (1304 MINIMUM AI2) at 20% (2 V or 4 mA). • Set parameter 3021 AI1 FAULT LIMIT to a value 5% or higher. • Set parameter 3001 AI<MIN FUNCTION to 1 (FAULT). <p>4 = AI2/JOYST – Defines analog input 2 (AI2), configured for joystick operation, as the reference source.</p> <ul style="list-style-type: none"> • See above (AI1/JOYST) description.

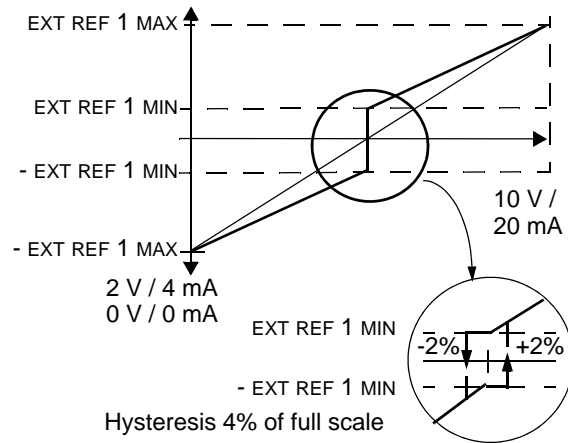

Code	Description
5	= DI3U,4D(R) – Defines digital inputs as the speed reference source (motor potentiometer control). <ul style="list-style-type: none"> • Digital input DI3 increases the speed (the U stands for “up”). • Digital input DI4 decreases the speed (the D stands for “down”). • A Stop command resets the reference to zero (the R stands for “reset”). • Parameter 2205 ACCELER TIME 2 controls the reference signal's rate of change.
6	= DI3U,4D – Same as above (DI3U,4D(R)), except: <ul style="list-style-type: none"> • A Stop command does not reset the reference to zero. The reference is stored. • When the drive restarts, the motor ramps up (at the selected acceleration rate) to the stored reference.
7	= DI5U,6D – Same as above (DI3U,4D), except that DI5 and DI6 are the digital inputs used.
8	= COMM – Defines the fieldbus as the reference source.
9	= COMM+AI1 – Defines a fieldbus and analog input 1 (AI1) combination as the reference source. See Analog input reference correction below.
10	= COMM*AI1 – Defines a fieldbus and analog input 1 (AI1) combination as the reference source. See Analog input reference correction below.
11	= DI3U,4D(RNC) – Same as DI3U,4D(R) above, except that: <ul style="list-style-type: none"> • Changing the control source (EXT1 to EXT2, EXT2 to EXT1, LOC to REM) does not copy the reference.
12	= DI3U,4D(NC) – Same as DI3U,4D above, except that: <ul style="list-style-type: none"> • Changing the control source (EXT1 to EXT2, EXT2 to EXT1, LOC to REM) does not copy the reference.
13	= DI5U,6D(NC) – Same as DI5U,6D above, except that: <ul style="list-style-type: none"> • Changing the control source (EXT1 to EXT2, EXT2 to EXT1, LOC to REM) does not copy the reference.
14	= AI1+AI2 – Defines an analog input 1 (AI1) and analog input 2 (AI2) combination as the reference source. See Analog input reference correction below.
15	= AI1*AI2 – Defines an analog input 1 (AI1) and analog input 2 (AI2) combination as the reference source. See Analog input reference correction below.
16	= AI1-AI2 – Defines an analog input 1 (AI1) and analog input 2 (AI2) combination as the reference source. See Analog input reference correction below.
17	= AI1/AI2 – Defines an analog input 1 (AI1) and analog input 2 (AI2) combination as the reference source. See Analog input reference correction below.
20	= KEYPAD(RNC) – Defines the control panel as the reference source. <ul style="list-style-type: none"> • A Stop command resets the reference to zero (the R stands for reset.). • Changing the control source (EXT1 to EXT2, EXT2 to EXT1) does not copy the reference.
21	= KEYPAD(NC) – Defines the control panel as the reference source. <ul style="list-style-type: none"> • A Stop command does not reset the reference to zero. The reference is stored. • Changing the control source (EXT1 to EXT2, EXT2 to EXT1) does not copy the reference.

Analog input reference correction

Parameter values 9, 10 and 14...17 use the formula in the following table.

Value setting	Calculation of the AI reference
C + B	C value + (B value - 50% of reference value)
C * B	C value * (B value / 50% of reference value)
C - B	(C value + 50% of reference value) - B value
C / B	(C value * 50% of reference value) / B value

Where:

- C = Main reference value
(= COMM for values 9, 10 and = AI1 for values 14...17).
- B = Correcting reference
(= AI1 for values 9, 10 and = AI2 for values 14...17).

Example:

The figure shows the reference source curves for value settings 9, 10 and 14...17, where:

- C = 25%.
- P 4012 SETPOINT MIN = 0.
- P 4013 SETPOINT MAX = 0.
- B varies along the horizontal axis.

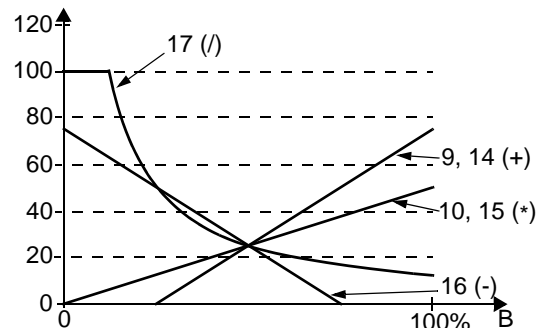

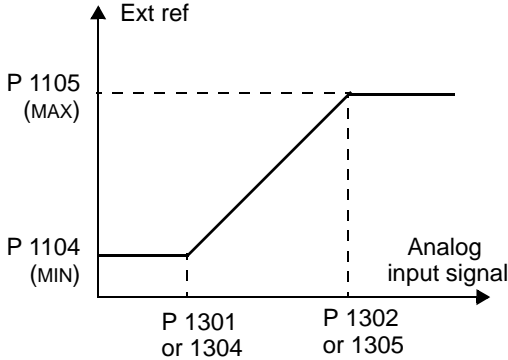
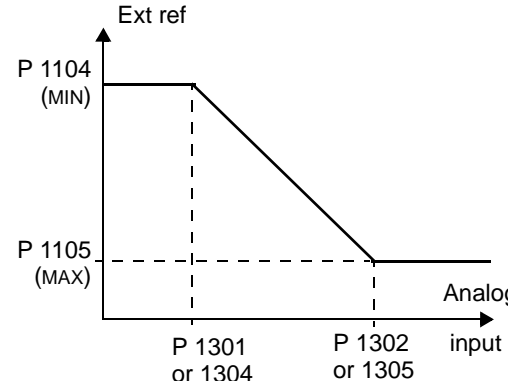
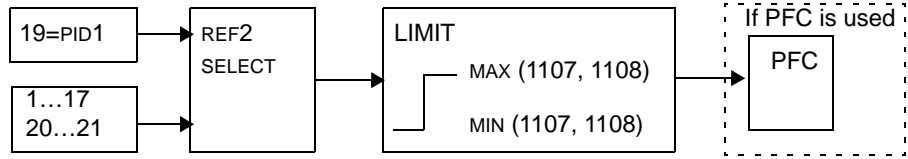
Code	Description	
1104	<p>REF1 MIN</p> <p>Sets the minimum for external reference 1.</p> <ul style="list-style-type: none"> The minimum analog input signal (as a percent of the full signal in volts or amperes) corresponds to REF1 MIN in Hz/rpm. Parameter 1301 MINIMUM AI1 or 1304 MINIMUM AI2 sets the minimum analog input signal. These parameters (reference and analog min. and max. settings) provide scale and offset adjustment for the reference. 	
1105	<p>REF1 MAX</p> <p>Sets the maximum for external reference 1.</p> <ul style="list-style-type: none"> The maximum analog input signal (as a percent of full the signal in volts or amperes) corresponds to REF1 MAX in Hz/rpm. Parameter 1302 MAXIMUM AI1 or 1305 MAXIMUM AI2 sets the maximum analog input signal. 	
1106	<p>REF2 SELECT</p> <p>Selects the signal source for external reference REF2.</p> <p>0...17 – Same as for parameter 1103 REF1 SELECT.</p> <p>19 = PID1OUT – The reference is taken from the PID1 output. See Group 40: PROCESS PID SET 1 and Group 41: PROCESS PID SET 2.</p> <p>20...21 – Same as for parameter 1103 REF1 SELECT.</p>	
1107	<p>REF2 MIN</p> <p>Sets the minimum for external reference 2.</p> <ul style="list-style-type: none"> The minimum analog input signal (in volts or amperes) corresponds to REF2 MIN in %. Parameter 1301 MINIMUM AI1 or 1304 MINIMUM AI2 sets the minimum analog input signal. This parameter sets the minimum frequency reference. The value is a percentage of the: <ul style="list-style-type: none"> – maximum frequency or speed – maximum process reference – nominal torque. 	
1108	<p>REF2 MAX</p> <p>Sets the maximum for external reference 2.</p> <ul style="list-style-type: none"> The maximum analog input signal (in volts or amperes) corresponds to REF2 MAX in %. Parameter 1302 MAXIMUM AI1 or 1305 MAXIMUM AI2 sets the maximum analog input signal. This parameter sets the maximum frequency reference. The value is a percentage of the: <ul style="list-style-type: none"> – maximum frequency or speed – maximum process reference – nominal torque. 	

Group 12: CONSTANT SPEEDS

This group defines a set of constant speeds. In general:

- You can program up to 7 constant speeds, ranging from 0...500 Hz or 0...30000 rpm.
- Values must be positive (No negative speed values for constant speeds).
- Constant speed selections are ignored if:
 - the process PID reference is followed, or
 - the drive is in local control mode, or
 - PFC (Pump-Fan Control) is active.

Note: Parameter 1208 CONST SPEED 7 acts also as a so-called fault speed which may be activated if the control signal is lost. For example, see parameters 3001 AI<MIN FUNCTION, 3002 PANEL COMM ERR and 3018 COMM FAULT FUNC.

Code	Description																																																			
1201	<p>CONST SPEED SEL Defines the digital inputs used to select Constant Speeds. See general comments in introduction. 0 = NOT SEL – Disables the constant speed function. 1 = DI1 – Selects Constant Speed 1 with digital input DI1. • Digital input activated = Constant Speed 1 activated. 2...6 = DI2...DI6 – Selects Constant Speed 1 with digital input DI2...DI6. See above. 7 = DI1,2 – Selects one of three Constant Speeds (1...3) using DI1 and DI2. • Uses two digital inputs, as defined below (0 = DI de-activated, 1 = DI activated):</p> <table border="1"> <thead> <tr> <th>DI1</th> <th>DI2</th> <th>Function</th> </tr> </thead> <tbody> <tr> <td>0</td> <td>0</td> <td>No constant speed</td> </tr> <tr> <td>1</td> <td>0</td> <td>Constant speed 1 (1202)</td> </tr> <tr> <td>0</td> <td>1</td> <td>Constant speed 2 (1203)</td> </tr> <tr> <td>1</td> <td>1</td> <td>Constant speed 3 (1204)</td> </tr> </tbody> </table> <p>• Can be set up as a so-called fault speed, which is activated if the control signal is lost. Refer to parameter 3001 AI<MIN function and parameter 3002 PANEL COMM ERR. 8 = DI2,3 – Selects one of three Constant Speeds (1...3) using DI2 and DI3. • See above (DI1,2) for code. 9 = DI3,4 – Selects one of three Constant Speeds (1...3) using DI3 and DI4. • See above (DI1,2) for code. 10 = DI4,5 – Selects one of three Constant Speeds (1...3) using DI4 and DI5. • See above (DI1,2) for code. 11 = DI5,6 – Selects one of three Constant Speeds (1...3) using DI5 and DI6. • See above (DI1,2) for code. 12 = DI1,2,3 – Selects one of seven Constant Speeds (1...7) using DI1, DI2 and DI3. • Uses three digital inputs, as defined below (0 = DI de-activated, 1 = DI activated):</p> <table border="1"> <thead> <tr> <th>DI1</th> <th>DI2</th> <th>DI3</th> <th>Function</th> </tr> </thead> <tbody> <tr> <td>0</td> <td>0</td> <td>0</td> <td>No constant speed</td> </tr> <tr> <td>1</td> <td>0</td> <td>0</td> <td>Constant speed 1 (1202)</td> </tr> <tr> <td>0</td> <td>1</td> <td>0</td> <td>Constant speed 2 (1203)</td> </tr> <tr> <td>1</td> <td>1</td> <td>0</td> <td>Constant speed 3 (1204)</td> </tr> <tr> <td>0</td> <td>0</td> <td>1</td> <td>Constant speed 4 (1205)</td> </tr> <tr> <td>1</td> <td>0</td> <td>1</td> <td>Constant speed 5 (1206)</td> </tr> <tr> <td>0</td> <td>1</td> <td>1</td> <td>Constant speed 6 (1207)</td> </tr> <tr> <td>1</td> <td>1</td> <td>1</td> <td>Constant speed 7 (1208)</td> </tr> </tbody> </table>	DI1	DI2	Function	0	0	No constant speed	1	0	Constant speed 1 (1202)	0	1	Constant speed 2 (1203)	1	1	Constant speed 3 (1204)	DI1	DI2	DI3	Function	0	0	0	No constant speed	1	0	0	Constant speed 1 (1202)	0	1	0	Constant speed 2 (1203)	1	1	0	Constant speed 3 (1204)	0	0	1	Constant speed 4 (1205)	1	0	1	Constant speed 5 (1206)	0	1	1	Constant speed 6 (1207)	1	1	1	Constant speed 7 (1208)
DI1	DI2	Function																																																		
0	0	No constant speed																																																		
1	0	Constant speed 1 (1202)																																																		
0	1	Constant speed 2 (1203)																																																		
1	1	Constant speed 3 (1204)																																																		
DI1	DI2	DI3	Function																																																	
0	0	0	No constant speed																																																	
1	0	0	Constant speed 1 (1202)																																																	
0	1	0	Constant speed 2 (1203)																																																	
1	1	0	Constant speed 3 (1204)																																																	
0	0	1	Constant speed 4 (1205)																																																	
1	0	1	Constant speed 5 (1206)																																																	
0	1	1	Constant speed 6 (1207)																																																	
1	1	1	Constant speed 7 (1208)																																																	

Code	Description																																																			
	<p>13 = DI3,4,5 – Selects one of seven Constant Speeds (1...7) using DI3, DI4 and DI5. • See above (DI1,2,3) for code.</p> <p>14 = DI4,5,6 – Selects one of seven Constant Speeds (1...7) using DI4, DI5 and DI6. • See above (DI1,2,3) for code.</p> <p>15...18 = TIMED FUNC 1...4 – Selects Constant Speed 1, Constant Speed 2 or the external reference, depending on the state of the Timed Function (1...4) and constant speed mode. See parameter 1209 TIMED MODE SEL and Group 36: TIMED FUNCTIONS.</p> <p>19 = TIMED FUN1&2 – Selects a constant speed or the external reference, depending on the state of Timed Functions 1 & 2 and constant speed mode. See parameter 1209 TIMED MODE SEL and Group 36: TIMED FUNCTIONS.</p> <p>-1 = DI1(INV) – Selects Constant Speed 1 with digital input DI1. • Inverse operation: Digital input de-activated = Constant Speed 1 activated.</p> <p>-2...-6 = DI2(INV)...DI6(INV) – Selects Constant Speed 1 with digital input. See above.</p> <p>-7 = DI1,2(INV) – Selects one of three Constant Speeds (1...3) using DI1 and DI2. • Inverse operation uses two digital inputs, as defined below (0 = DI de-activated, 1 = DI activated):</p> <table border="1" data-bbox="245 611 647 762"> <thead> <tr> <th>DI1</th> <th>DI2</th> <th>Function</th> </tr> </thead> <tbody> <tr> <td>1</td> <td>1</td> <td>No constant speed</td> </tr> <tr> <td>0</td> <td>1</td> <td>Constant speed 1 (1202)</td> </tr> <tr> <td>1</td> <td>0</td> <td>Constant speed 2 (1203)</td> </tr> <tr> <td>0</td> <td>0</td> <td>Constant speed 3 (1204)</td> </tr> </tbody> </table> <p>-8 = DI2,3(INV) – Selects one of three Constant Speeds (1...3) using DI2 and DI3. • See above (DI1,2(INV)) for code.</p> <p>-9 = DI3,4(INV) – Selects one of three Constant Speeds (1...3) using DI3 and DI4. • See above (DI1,2(INV)) for code.</p> <p>-10 = DI4,5(INV) – Selects one of three Constant Speeds (1...3) using DI4 and DI5. • See above (DI1,2(INV)) for code.</p> <p>-11 = DI5,6(INV) – Selects one of three Constant Speeds (1...3) using DI5 and DI6. • See above (DI1,2(INV)) for code.</p> <p>-12 = DI1,2,3(INV) – Selects one of seven Constant Speeds (1...7) using DI1, DI2 and DI3. • Inverse operation uses three digital inputs, as defined below (0 = DI de-activated, 1 = DI activated):</p> <table border="1" data-bbox="245 1062 696 1335"> <thead> <tr> <th>DI1</th> <th>DI2</th> <th>DI3</th> <th>Function</th> </tr> </thead> <tbody> <tr> <td>1</td> <td>1</td> <td>1</td> <td>No constant speed</td> </tr> <tr> <td>0</td> <td>1</td> <td>1</td> <td>Constant speed 1 (1202)</td> </tr> <tr> <td>1</td> <td>0</td> <td>1</td> <td>Constant speed 2 (1203)</td> </tr> <tr> <td>0</td> <td>0</td> <td>1</td> <td>Constant speed 3 (1204)</td> </tr> <tr> <td>1</td> <td>1</td> <td>0</td> <td>Constant speed 4 (1205)</td> </tr> <tr> <td>0</td> <td>1</td> <td>0</td> <td>Constant speed 5 (1206)</td> </tr> <tr> <td>1</td> <td>0</td> <td>0</td> <td>Constant speed 6 (1207)</td> </tr> <tr> <td>0</td> <td>0</td> <td>0</td> <td>Constant speed 7 (1208)</td> </tr> </tbody> </table> <p>-13 = DI3,4,5(INV) – Selects one of seven Constant Speeds (1...7) using DI3, DI4 and DI5. • See above (DI1,2,3(INV)) for code.</p> <p>-14 = DI4,5,6(INV) – Selects one of seven Constant Speeds (1...7) using DI4, DI5 and DI6. • See above (DI1,2,3(INV)) for code.</p>	DI1	DI2	Function	1	1	No constant speed	0	1	Constant speed 1 (1202)	1	0	Constant speed 2 (1203)	0	0	Constant speed 3 (1204)	DI1	DI2	DI3	Function	1	1	1	No constant speed	0	1	1	Constant speed 1 (1202)	1	0	1	Constant speed 2 (1203)	0	0	1	Constant speed 3 (1204)	1	1	0	Constant speed 4 (1205)	0	1	0	Constant speed 5 (1206)	1	0	0	Constant speed 6 (1207)	0	0	0	Constant speed 7 (1208)
DI1	DI2	Function																																																		
1	1	No constant speed																																																		
0	1	Constant speed 1 (1202)																																																		
1	0	Constant speed 2 (1203)																																																		
0	0	Constant speed 3 (1204)																																																		
DI1	DI2	DI3	Function																																																	
1	1	1	No constant speed																																																	
0	1	1	Constant speed 1 (1202)																																																	
1	0	1	Constant speed 2 (1203)																																																	
0	0	1	Constant speed 3 (1204)																																																	
1	1	0	Constant speed 4 (1205)																																																	
0	1	0	Constant speed 5 (1206)																																																	
1	0	0	Constant speed 6 (1207)																																																	
0	0	0	Constant speed 7 (1208)																																																	
1202	<p>CONST SPEED 1 Sets value for Constant Speed 1. • The range and units depend on parameter 9904 MOTOR CTRL MODE. • Range: 0...30000 rpm when 9904 = 1 or 2 (VECTOR:SPEED). • Range: 0...500 Hz when 9904 = 3 (SCALAR:FREQ).</p>																																																			
1203	<p>CONST SPEED 2...CONST SPEED 7 Each sets a value for a Constant Speed. See CONST SPEED 1 above.</p>																																																			
1208	<p>Constant Speed 7 is used also as jogging speed. See parameter 1004 JOGGING SEL.</p>																																																			

Code	Description																																										
1209	<p>TIMED MODE SEL</p> <p>Defines timed function activated constant speed mode. Timed function can be used to change between the external reference and constant speeds when parameter 1201 CONST SPEED SEL = 15...18 (TIMED FUNC 1...4) or 19 (TIMED FUN1&2).</p> <p>1 = EXT/CS1/2/3</p> <ul style="list-style-type: none"> If parameter 1201 = 15...18 (TIMED FUNC 1...4), selects an external speed when this timed function (1...4) is not active and selects Constant speed 1 when it is active. <table border="1"> <thead> <tr> <th>TIMED FUNCTION 1...4</th> <th>Function</th> </tr> </thead> <tbody> <tr> <td>0</td> <td>External reference</td> </tr> <tr> <td>1</td> <td>Constant speed 1 (1202)</td> </tr> </tbody> </table> <ul style="list-style-type: none"> If parameter 1201 = 19 (TIMED FUN1&2), selects an external speed when neither timed function is active, selects Constant speed 1 when only Timed function 1 is active, selects Constant speed 2 when only Timed function 2 is active and selects Constant speed 3 when both Timed functions 1 and 2 are active. <table border="1"> <thead> <tr> <th>TIMED FUNCTION 1</th> <th>TIMED FUNCTION 2</th> <th>Function</th> </tr> </thead> <tbody> <tr> <td>0</td> <td>0</td> <td>External reference</td> </tr> <tr> <td>1</td> <td>0</td> <td>Constant speed 1 (1202)</td> </tr> <tr> <td>0</td> <td>1</td> <td>Constant speed 2 (1203)</td> </tr> <tr> <td>1</td> <td>1</td> <td>Constant speed 3 (1204)</td> </tr> </tbody> </table> <p>2 = CS1/2/3/4</p> <ul style="list-style-type: none"> If parameter 1201 = 15...18 (TIMED FUNC 1...4), selects Constant speed 1 when this timed function (1...4) is not active and selects Constant speed 2 when it is active. <table border="1"> <thead> <tr> <th>TIMED FUNCTION 1...4</th> <th>Function</th> </tr> </thead> <tbody> <tr> <td>0</td> <td>Constant speed 1 (1202)</td> </tr> <tr> <td>1</td> <td>Constant speed 2 (1203)</td> </tr> </tbody> </table> <ul style="list-style-type: none"> If parameter 1201 = 19 (TIMED FUN1&2), selects Constant speed 1 when neither timed function is active, selects Constant speed 2 when only Timed function 1 is active, selects Constant speed 3 when only Timed function 2 is active and selects Constant speed 4 when both Timed functions 1 and 2 are active. <table border="1"> <thead> <tr> <th>TIMED FUNCTION 1</th> <th>TIMED FUNCTION 2</th> <th>Function</th> </tr> </thead> <tbody> <tr> <td>0</td> <td>0</td> <td>Constant speed 1 (1202)</td> </tr> <tr> <td>1</td> <td>0</td> <td>Constant speed 2 (1203)</td> </tr> <tr> <td>0</td> <td>1</td> <td>Constant speed 3 (1204)</td> </tr> <tr> <td>1</td> <td>1</td> <td>Constant speed 4 (1205)</td> </tr> </tbody> </table>	TIMED FUNCTION 1...4	Function	0	External reference	1	Constant speed 1 (1202)	TIMED FUNCTION 1	TIMED FUNCTION 2	Function	0	0	External reference	1	0	Constant speed 1 (1202)	0	1	Constant speed 2 (1203)	1	1	Constant speed 3 (1204)	TIMED FUNCTION 1...4	Function	0	Constant speed 1 (1202)	1	Constant speed 2 (1203)	TIMED FUNCTION 1	TIMED FUNCTION 2	Function	0	0	Constant speed 1 (1202)	1	0	Constant speed 2 (1203)	0	1	Constant speed 3 (1204)	1	1	Constant speed 4 (1205)
TIMED FUNCTION 1...4	Function																																										
0	External reference																																										
1	Constant speed 1 (1202)																																										
TIMED FUNCTION 1	TIMED FUNCTION 2	Function																																									
0	0	External reference																																									
1	0	Constant speed 1 (1202)																																									
0	1	Constant speed 2 (1203)																																									
1	1	Constant speed 3 (1204)																																									
TIMED FUNCTION 1...4	Function																																										
0	Constant speed 1 (1202)																																										
1	Constant speed 2 (1203)																																										
TIMED FUNCTION 1	TIMED FUNCTION 2	Function																																									
0	0	Constant speed 1 (1202)																																									
1	0	Constant speed 2 (1203)																																									
0	1	Constant speed 3 (1204)																																									
1	1	Constant speed 4 (1205)																																									

Group 13: ANALOG INPUTS

This group defines the limits and the filtering for analog inputs.

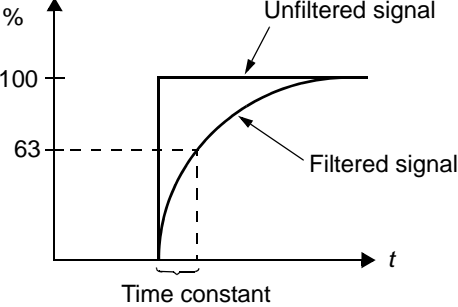
Code	Description
1301	<p>MINIMUM AI1</p> <p>Defines the minimum value of the analog input.</p> <ul style="list-style-type: none"> Define value as a percent of the full analog signal range. See example below. The minimum analog input signal corresponds to 1104 REF1 MIN or 1107 REF2 MIN. MINIMUM AI cannot be greater than MAXIMUM AI. These parameters (reference and analog min. and max. settings) provide scale and offset adjustment for the reference. See the figure at parameter 1104. <p>Example: To set the minimum analog input value to 4 mA:</p> <ul style="list-style-type: none"> Configure the analog input for 0...20 mA current signal. Calculate the minimum (4 mA) as a percent of full range (20 mA) = $4 \text{ mA} / 20 \text{ mA} \cdot 100\% = 20\%$
1302	<p>MAXIMUM AI1</p> <p>Defines the maximum value of the analog input.</p> <ul style="list-style-type: none"> Define value as a percent of the full analog signal range. The maximum analog input signal corresponds to 1105 REF1 MAX or 1108 REF2 MAX. See the figure at parameter 1104.
1303	<p>FILTER AI1</p> <p>Defines the filter time constant for analog input 1 (AI1).</p> <ul style="list-style-type: none"> The filtered signal reaches 63% of a step change within the time specified. 
1304	<p>MINIMUM AI2</p> <p>Defines the minimum value of the analog input.</p> <ul style="list-style-type: none"> See MINIMUM AI1 above.
1305	<p>MAXIMUM AI2</p> <p>Defines the maximum value of the analog input.</p> <ul style="list-style-type: none"> See MAXIMUM AI1 above.
1306	<p>FILTER AI2</p> <p>Defines the filter time constant for analog input 2 (AI2).</p> <ul style="list-style-type: none"> See FILTER AI1 above.

Group 14: RELAY OUTPUTS

This group defines the condition that activates each of the relay outputs. Relay outputs 4...6 are only available if OREL-01 Relay Output Extension Module is installed.

Code	Description
1401	<p>RELAY OUTPUT 1</p> <p>Defines the event or condition that activates relay 1 – what relay output 1 means.</p> <p>0 = NOT SEL – Relay is not used and is de-energized.</p> <p>1 = READY – Energize relay when drive is ready to function. Requires:</p> <ul style="list-style-type: none"> • Run enable signal present. • No faults exist. • Supply voltage is within range. • Emergency Stop command is not on. <p>2 = RUN – Energize relay when the drive is running.</p> <p>3 = FAULT(-1) – Energize relay when power is applied. De-energizes when a fault occurs.</p> <p>4 = FAULT – Energize relay when a fault is active.</p> <p>5 = ALARM – Energize relay when an alarm is active.</p> <p>6 = REVERSED – Energize relay when motor rotates in reverse direction.</p> <p>7 = STARTED – Energize relay when drive receives a start command (even if Run Enable signal is not present). De-energized relay when drive receives a stop command or a fault occurs.</p> <p>8 = SUPRV1 OVER – Energize relay when first supervised parameter (3201) exceeds the limit (3203).</p> <ul style="list-style-type: none"> • See Group 32: SUPERVISION starting on page 129. <p>9 = SUPRV1 UNDER – Energize relay when first supervised parameter (3201) drops below the limit (3202).</p> <ul style="list-style-type: none"> • See Group 32: SUPERVISION starting on page 129. <p>10 = SUPRV2 OVER – Energize relay when second supervised parameter (3204) exceeds the limit (3206).</p> <ul style="list-style-type: none"> • See Group 32: SUPERVISION starting on page 129. <p>11 = SUPRV2 UNDER – Energize relay when second supervised parameter (3204) drops below the limit (3205).</p> <ul style="list-style-type: none"> • See Group 32: SUPERVISION starting on page 129. <p>12 = SUPRV3 OVER – Energize relay when third supervised parameter (3207) exceeds the limit (3209).</p> <ul style="list-style-type: none"> • See Group 32: SUPERVISION starting on page 129. <p>13 = SUPRV3 UNDER – Energize relay when third supervised parameter (3207) drops below the limit (3208).</p> <ul style="list-style-type: none"> • See Group 32: SUPERVISION starting on page 129. <p>14 = AT SET POINT – Energize relay when the output frequency is equal to the reference frequency.</p> <p>15 = FAULT(RST) – Energize relay when the drive is in a fault condition and will reset after the programmed auto-reset delay.</p> <ul style="list-style-type: none"> • See parameter 3103 DELAY TIME. <p>16 = FLT/ALARM – Energize relay when fault or alarm occurs.</p> <p>17 = EXT CTRL – Energize relay when external control is selected.</p> <p>18 = REF 2 SEL – Energize relay when EXT2 is selected.</p> <p>19 = CONST FREQ – Energize relay when a constant speed is selected.</p> <p>20 = REF LOSS – Energize relay when reference or active control place is lost.</p> <p>21 = OVERCURRENT – Energize relay when an overcurrent alarm or fault occurs.</p> <p>22 = OVERVOLTAGE – Energize relay when an overvoltage alarm or fault occurs.</p> <p>23 = DRIVE TEMP – Energize relay when a drive or control board overtemperature alarm or fault occurs.</p> <p>24 = UNDERVOLTAGE – Energize relay when an undervoltage alarm or fault occurs.</p> <p>25 = AI1 LOSS – Energize relay when AI1 signal is lost.</p> <p>26 = AI2 LOSS – Energize relay when AI2 signal is lost.</p> <p>27 = MOTOR TEMP – Energize relay when a motor overtemperature alarm or fault occurs.</p> <p>28 = STALL – Energize relay when a stall alarm or fault exists.</p> <p>30 = PID SLEEP – Energize relay when the PID sleep function is active.</p> <p>31 = PFC – Use relay to start/stop motor in PFC control (See Group 81: PFC CONTROL).</p> <ul style="list-style-type: none"> • Use this option only when PFC control is used. • Selection activated / deactivated when drive is not running. <p>32 = AUTOCHANGE – Energize relay when PFC autochange operation is performed.</p> <ul style="list-style-type: none"> • Use this option only when PFC control is used. <p>33 = FLUX READY – Energize relay when the motor is magnetized and able to supply nominal torque (motor has reached nominal magnetizing).</p> <p>34 = USER MACRO 2 – Energize relay when User Parameter Set 2 is active.</p>

Code	Description																																																																																																																																
	<p>35 = COMM – Energize relay based on input from fieldbus communication.</p> <ul style="list-style-type: none"> Fieldbus writes binary code in parameter 0134 that can energize relay 1...relay 6 according to the following: <table border="1"> <thead> <tr> <th>Par. 0134</th> <th>Binary</th> <th>RO6</th> <th>RO5</th> <th>RO4</th> <th>RO3</th> <th>RO2</th> <th>RO1</th> </tr> </thead> <tbody> <tr> <td>0</td> <td>000000</td> <td>0</td> <td>0</td> <td>0</td> <td>0</td> <td>0</td> <td>0</td> </tr> <tr> <td>1</td> <td>000001</td> <td>0</td> <td>0</td> <td>0</td> <td>0</td> <td>0</td> <td>1</td> </tr> <tr> <td>2</td> <td>000010</td> <td>0</td> <td>0</td> <td>0</td> <td>0</td> <td>1</td> <td>0</td> </tr> <tr> <td>3</td> <td>000011</td> <td>0</td> <td>0</td> <td>0</td> <td>0</td> <td>1</td> <td>1</td> </tr> <tr> <td>4</td> <td>000100</td> <td>0</td> <td>0</td> <td>0</td> <td>1</td> <td>0</td> <td>0</td> </tr> <tr> <td>5...62</td> <td>...</td> <td>...</td> <td>...</td> <td>...</td> <td>...</td> <td>...</td> <td>...</td> </tr> <tr> <td>63</td> <td>111111</td> <td>1</td> <td>1</td> <td>1</td> <td>1</td> <td>1</td> <td>1</td> </tr> </tbody> </table> <ul style="list-style-type: none"> 0 = De-energize relay, 1 = Energize relay. <p>36 = COMM(-1) – Energize relay based on input from fieldbus communication.</p> <ul style="list-style-type: none"> Fieldbus writes binary code in parameter 0134 that can energize relay 1...relay 6 according to the following: <table border="1"> <thead> <tr> <th>Par. 0134</th> <th>Binary</th> <th>RO6</th> <th>RO5</th> <th>RO4</th> <th>RO3</th> <th>RO2</th> <th>RO1</th> </tr> </thead> <tbody> <tr> <td>0</td> <td>000000</td> <td>1</td> <td>1</td> <td>1</td> <td>1</td> <td>1</td> <td>1</td> </tr> <tr> <td>1</td> <td>000001</td> <td>1</td> <td>1</td> <td>1</td> <td>1</td> <td>1</td> <td>0</td> </tr> <tr> <td>2</td> <td>000010</td> <td>1</td> <td>1</td> <td>1</td> <td>1</td> <td>0</td> <td>1</td> </tr> <tr> <td>3</td> <td>000011</td> <td>1</td> <td>1</td> <td>1</td> <td>1</td> <td>0</td> <td>0</td> </tr> <tr> <td>4</td> <td>000100</td> <td>1</td> <td>1</td> <td>1</td> <td>0</td> <td>1</td> <td>1</td> </tr> <tr> <td>5...62</td> <td>...</td> <td>...</td> <td>...</td> <td>...</td> <td>...</td> <td>...</td> <td>...</td> </tr> <tr> <td>63</td> <td>111111</td> <td>0</td> <td>0</td> <td>0</td> <td>0</td> <td>0</td> <td>0</td> </tr> </tbody> </table> <ul style="list-style-type: none"> 0 = De-energize relay, 1 = Energize relay. <p>37 = TIMED FUNC 1 – Energize relay when Timed Function 1 is active. See Group 36: TIMED FUNCTIONS.</p> <p>38...40 = TIMED FUNC 2...4 – Energize relay when Timed Function 2...4 is active. See TIMED FUNC 1 above.</p> <p>41 = MNT TRIG FAN – Energize relay when cooling fan counter is triggered. See Group 29: MAINTENANCE TRIG.</p> <p>42 = MNT TRIG REV – Energize relay when revolutions counter is triggered. See Group 29: MAINTENANCE TRIG.</p> <p>43 = MNT TRIG RUN – Energize relay when run time counter is triggered. See Group 29: MAINTENANCE TRIG.</p> <p>44 = MNT TRIG MWH – Energize relay when MWh counter is triggered. See Group 29: MAINTENANCE TRIG.</p> <p>46 = START DELAY – Energize relay when a start delay is active.</p> <p>47 = USER LOAD C – Energize relay when a user load curve fault or alarm occurs.</p> <p>52 = JOG ACTIVE – Energize relay when the jogging function is active.</p>	Par. 0134	Binary	RO6	RO5	RO4	RO3	RO2	RO1	0	000000	0	0	0	0	0	0	1	000001	0	0	0	0	0	1	2	000010	0	0	0	0	1	0	3	000011	0	0	0	0	1	1	4	000100	0	0	0	1	0	0	5...62	63	111111	1	1	1	1	1	1	Par. 0134	Binary	RO6	RO5	RO4	RO3	RO2	RO1	0	000000	1	1	1	1	1	1	1	000001	1	1	1	1	1	0	2	000010	1	1	1	1	0	1	3	000011	1	1	1	1	0	0	4	000100	1	1	1	0	1	1	5...62	63	111111	0	0	0	0	0	0
Par. 0134	Binary	RO6	RO5	RO4	RO3	RO2	RO1																																																																																																																										
0	000000	0	0	0	0	0	0																																																																																																																										
1	000001	0	0	0	0	0	1																																																																																																																										
2	000010	0	0	0	0	1	0																																																																																																																										
3	000011	0	0	0	0	1	1																																																																																																																										
4	000100	0	0	0	1	0	0																																																																																																																										
5...62																																																																																																																										
63	111111	1	1	1	1	1	1																																																																																																																										
Par. 0134	Binary	RO6	RO5	RO4	RO3	RO2	RO1																																																																																																																										
0	000000	1	1	1	1	1	1																																																																																																																										
1	000001	1	1	1	1	1	0																																																																																																																										
2	000010	1	1	1	1	0	1																																																																																																																										
3	000011	1	1	1	1	0	0																																																																																																																										
4	000100	1	1	1	0	1	1																																																																																																																										
5...62																																																																																																																										
63	111111	0	0	0	0	0	0																																																																																																																										
1402	<p>RELAY OUTPUT 2</p> <p>Defines the event or condition that activates relay 2 – what relay output 2 means.</p> <ul style="list-style-type: none"> See 1401 RELAY OUTPUT 1. 																																																																																																																																
1403	<p>RELAY OUTPUT 3</p> <p>Defines the event or condition that activates relay 3 – what relay output 3 means.</p> <ul style="list-style-type: none"> See 1401 RELAY OUTPUT 1. 																																																																																																																																
1404	<p>RO 1 ON DELAY</p> <p>Defines the switch-on delay for relay 1.</p> <ul style="list-style-type: none"> On / off delays are ignored when relay output 1401 is set to PFC. 																																																																																																																																
1405	<p>RO 1 OFF DELAY</p> <p>Defines the switch-off delay for relay 1.</p> <ul style="list-style-type: none"> On / off delays are ignored when relay output 1401 is set to PFC. 																																																																																																																																
1406	<p>RO 2 ON DELAY</p> <p>Defines the switch-on delay for relay 2.</p> <ul style="list-style-type: none"> See RO 1 ON DELAY. 																																																																																																																																
1407	<p>RO 2 OFF DELAY</p> <p>Defines the switch-off delay for relay 2.</p> <ul style="list-style-type: none"> See RO 1 OFF DELAY. 																																																																																																																																
1408	<p>RO 3 ON DELAY</p> <p>Defines the switch-on delay for relay 3.</p> <ul style="list-style-type: none"> See RO 1 ON DELAY. 																																																																																																																																

Code	Description
1409	RO 3 OFF DELAY Switch-off delay for relay 3. • See RO 1 OFF DELAY.
1410	RELAY OUTPUT 4...6 Defines the event or condition that activates relay 4...6 – what relay output 4...6 means. Available if OREL-01 Relay Output Extension Module is installed.
1412	• See 1401 RELAY OUTPUT 1.
1413	RO 4 ON DELAY Defines the switch-on delay for relay 4. • See RO 1 ON DELAY.
1414	RO 4 OFF DELAY Defines the switch-off delay for relay 4. • See RO 1 OFF DELAY.
1415	RO 5 ON DELAY Defines the switch-on delay for relay 5. • See RO 1 ON DELAY.
1416	RO 5 OFF DELAY Defines the switch-off delay for relay 5. • See RO 1 OFF DELAY.
1417	RO 6 ON DELAY Defines the switch-on delay for relay 6. • See RO 1 ON DELAY.
1418	RO 6 OFF DELAY Defines the switch-off delay for relay 6. • See RO 1 OFF DELAY.

Group 15: ANALOG OUTPUTS

This group defines the drive's analog (current signal) outputs. The drive's analog outputs can be:

- any parameter in [Group 01: OPERATING DATA](#)
- limited to programmable minimum and maximum values of output current
- scaled (and/or inverted) by defining the minimum and maximum values of the source parameter (or content). Defining an maximum value (parameter 1503 or 1509) that is less than the content minimum value (parameter 1502 or 1508) results in an inverted output.
- filtered.

Code	Description
1501	<p>AO1 CONTENT SEL Defines the content for analog output AO1. 99 = EXCITE PTC – Provides a current source for sensor type PTC. Output = 1.6 mA. See Group 35: MOTOR TEMP MEAS. 100 = EXCITE PT100 – Provides a current source for sensor type PT100. Output = 9.1 mA. See Group 35: MOTOR TEMP MEAS. 101...178 – Output corresponds to a parameter in Group 01: OPERATING DATA.</p> <ul style="list-style-type: none"> • Parameter defined by value (value 102 = parameter 0102)
1502	<p>AO1 CONTENT MIN Sets the minimum content value.</p> <ul style="list-style-type: none"> • Content is the parameter selected by parameter 1501. • Minimum value refers to the minimum content value that will be converted to an analog output. • These parameters (content and current min. and max. settings) provide scale and offset adjustment for the output. See the figure.
1503	<p>AO1 CONTENT MAX Sets the maximum content value</p> <ul style="list-style-type: none"> • Content is the parameter selected by parameter 1501. • Maximum value refers to the maximum content value that will be converted to an analog output.
1504	<p>MINIMUM AO1 Sets the minimum output current.</p>
1505	<p>MAXIMUM AO1 Sets the maximum output current.</p>
1506	<p>FILTER AO1 Defines the filter time constant for AO1.</p> <ul style="list-style-type: none"> • The filtered signal reaches 63% of a step change within the time specified. • See the figure in parameter 1303.
1507	<p>AO2 CONTENT SEL Defines the content for analog output AO2. See AO1 CONTENT SEL above.</p>
1508	<p>AO2 CONTENT MIN Sets the minimum content value. See AO1 CONTENT MIN above.</p>
1509	<p>AO2 CONTENT MAX Sets the maximum content value. See AO1 CONTENT MAX above.</p>
1510	<p>MINIMUM AO2 Sets the minimum output current. See MINIMUM AO1 above.</p>

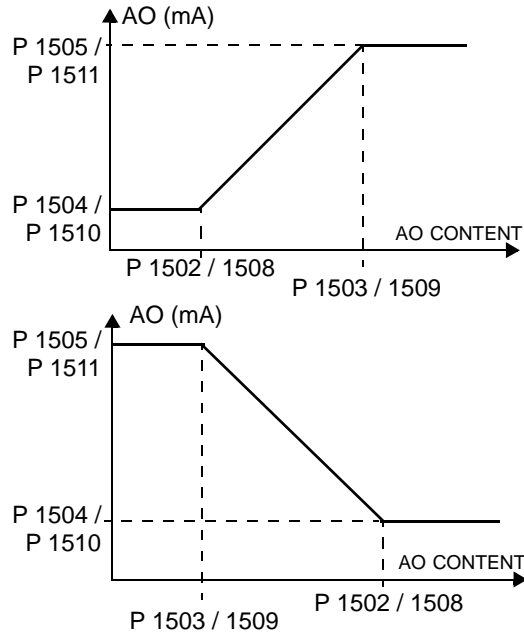

Code	Description
1511	MAXIMUM AO2 Sets the maximum output current. See MAXIMUM AO1 above.
1512	FILTER AO2 Defines the filter time constant for AO2. See FILTER AO1 above.

Group 16: SYSTEM CONTROLS

This group defines a variety of system level locks, resets and enables.

Code	Description
1601	<p>RUN ENABLE</p> <p>Selects the source of the run enable signal.</p> <p>0 = NOT SEL – Allows the drive to start without an external run enable signal.</p> <p>1 = DI1 – Defines digital input DI1 as the run enable signal.</p> <ul style="list-style-type: none"> This digital input must be activated for run enable. If the voltage drops and de-activates this digital input, the drive will coast to stop and not start until the run enable signal resumes. <p>2...6 = DI2...DI6 – Defines digital input DI2...DI6 as the run enable signal.</p> <ul style="list-style-type: none"> See DI1 above. <p>7 = COMM – Assigns the fieldbus Command Word as the source for the run enable signal.</p> <ul style="list-style-type: none"> Bit 6 of the Command Word 1 (parameter 0301) activates the run disable signal. See fieldbus user's manual for detailed instructions. <p>-1 = DI1(INV) – Defines an inverted digital input DI1 as the run enable signal.</p> <ul style="list-style-type: none"> This digital input must be de-activated for run enable. If this digital input activates, the drive will coast to stop and not start until the run enable signal resumes. <p>-2...-6 = DI2(INV)...DI6(INV) – Defines an inverted digital input DI2...DI6 as the run enable signal.</p> <ul style="list-style-type: none"> See DI1(INV) above.
1602	<p>PARAMETER LOCK</p> <p>Determines if the control panel can change parameter values.</p> <ul style="list-style-type: none"> This lock does not limit parameter changes made by macros. This lock does not limit parameter changes written by fieldbus inputs. This parameter value can be changed only if the correct pass code is entered. See parameter 1603 PASS CODE. <p>0 = LOCKED – You cannot use the control panel to change parameter values.</p> <ul style="list-style-type: none"> The lock can be opened by entering the valid pass code to parameter 1603. <p>1 = OPEN – You can use the control panel to change parameter values.</p> <p>2 = NOT SAVED – You can use the control panel to change parameter values, but they are not stored in permanent memory.</p> <ul style="list-style-type: none"> Set parameter 1607 PARAM SAVE to 1 (SAVE) to store changed parameter values to memory.
1603	<p>PASS CODE</p> <p>Entering the correct pass code allows you to change the parameter lock.</p> <ul style="list-style-type: none"> See parameter 1602 above. The code 358 allows you to change the value of the parameter 1602 once. This entry reverts back to 0 automatically.
1604	<p>FAULT RESET SEL</p> <p>Selects the source for the fault reset signal. The signal resets the drive after a fault trip if the cause of the fault no longer exists.</p> <p>0 = KEYPAD – Defines the control panel as the only fault reset source.</p> <ul style="list-style-type: none"> Fault reset is always possible with control panel. <p>1 = DI1 – Defines digital input DI1 as a fault reset source.</p> <ul style="list-style-type: none"> Activating the digital input resets the drive. <p>2...6 = DI2...DI6 – Defines digital input DI2...DI6 as a fault reset source.</p> <ul style="list-style-type: none"> See DI1 above. <p>7 = START/STOP – Defines the Stop command as a fault reset source.</p> <ul style="list-style-type: none"> Do not use this option when fieldbus communication provides the start, stop and direction commands. <p>8 = COMM – Defines the fieldbus as a fault reset source.</p> <ul style="list-style-type: none"> The Command Word is supplied through fieldbus communication. The bit 4 of the Command Word 1 (parameter 0301) resets the drive. <p>-1 = DI1(INV) – Defines an inverted digital input DI1 as a fault reset source.</p> <ul style="list-style-type: none"> De-activating the digital input resets the drive. <p>-2...-6 = DI2(INV)...DI6(INV) – Defines an inverted digital input DI2...DI6 as a fault reset source.</p> <ul style="list-style-type: none"> See DI1(INV) above.

Code	Description
1605	<p>USER PAR SET CHG</p> <p>Defines control for changing the user parameter set.</p> <ul style="list-style-type: none"> • See parameter 9902 APPLIC MACRO. • The drive must be stopped to change User Parameter Sets. • During a change, the drive will not start. <p>Note: Always save the User Parameter Set after changing any parameter settings, or performing a motor identification.</p> <ul style="list-style-type: none"> • Whenever the power is cycled, or parameter 9902 APPLIC MACRO is changed, the drive loads the last settings saved. Any unsaved changes to a user parameter set are lost. <p>Note: The value of this parameter (1605) is not included in the User Parameter Sets, and it does not change if User Parameter Sets change.</p> <p>Note: You can use a relay output to supervise the selection of User Parameter Set 2.</p> <ul style="list-style-type: none"> • See parameter 1401. <p>0 = NOT SEL – Defines the control panel (using parameter 9902) as the only control for changing User Parameter Sets.</p> <p>1 = DI1 – Defines digital input DI1 as a control for changing User Parameter Sets.</p> <ul style="list-style-type: none"> • The drive loads User Parameter Set 1 on the falling edge of the digital input. • The drive loads User Parameter Set 2 on the rising edge of the digital input. • The User Parameter Set changes only when the drive is stopped. <p>2...6 = DI2...DI6 – Defines digital input DI2...DI6 as a control for changing User Parameter Sets.</p> <ul style="list-style-type: none"> • See DI1 above. <p>-1 = DI1(INV) – Defines an inverted digital input DI1 as a control for changing User Parameter Sets.</p> <ul style="list-style-type: none"> • The drive loads User Parameter Set 1 on the rising edge of the digital input. • The drive loads User Parameter Set 2 on the falling edge of the digital input. • The User Parameter Set changes only when the drive is stopped. <p>-2...-6 = DI2(INV)...DI6(INV) – Defines an inverted digital input DI2...DI6 as a control for changing User Parameter Sets.</p> <ul style="list-style-type: none"> • See DI1(INV) above.
1607	<p>PARAM SAVE</p> <p>Saves all altered parameters to permanent memory.</p> <ul style="list-style-type: none"> • Parameters altered through a fieldbus are not automatically saved to permanent memory. To save, you must use this parameter. • If 1602 PARAMETER LOCK = 2 (NOT SAVED), parameters altered from the control panel are not saved. To save, you must use this parameter. • If 1602 PARAMETER LOCK = 1 (OPEN), parameters altered from the control panel are stored immediately to permanent memory. <p>0 = DONE – Value changes automatically when all parameters are saved.</p> <p>1 = SAVE... – Saves altered parameters to permanent memory.</p>

Code	Description
1608	<p>START ENABLE 1 Selects the source of the start enable 1 signal.</p> <p>Note: Start enable functionality differs from the run enable functionality.</p> <p>0 = NOT SEL – Allows the drive to start without an external start enable signal.</p> <p>1 = DI1 – Defines digital input DI1 as the start enable 1 signal.</p> <ul style="list-style-type: none"> • This digital input must be activated for start enable 1 signal. • If the voltage drops and de-activates this digital input, the drive will coast to stop and show alarm 2021 on the panel display. The drive will not start until start enable 1 signal resumes. <p>2...6 = DI2...DI6 – Defines digital input DI2...DI6 as the start enable 1 signal.</p> <ul style="list-style-type: none"> • See DI1 above. <p>7 = COMM – Assigns the fieldbus Command Word as the source for the start enable 1 signal.</p> <ul style="list-style-type: none"> • Bit 2 of the Command word 2 (parameter 0302) activates the start disable 1 signal. • See fieldbus user's manual for detailed instructions. <p>-1 = DI1(INV) – Defines an inverted digital input DI1 as the start enable 1 signal.</p> <p>-2...-6 = DI2 (INV)...DI6(INV) – Defines an inverted digital input DI2...DI6 as the start enable 1 signal.</p> <ul style="list-style-type: none"> • See DI1 (INV) above.

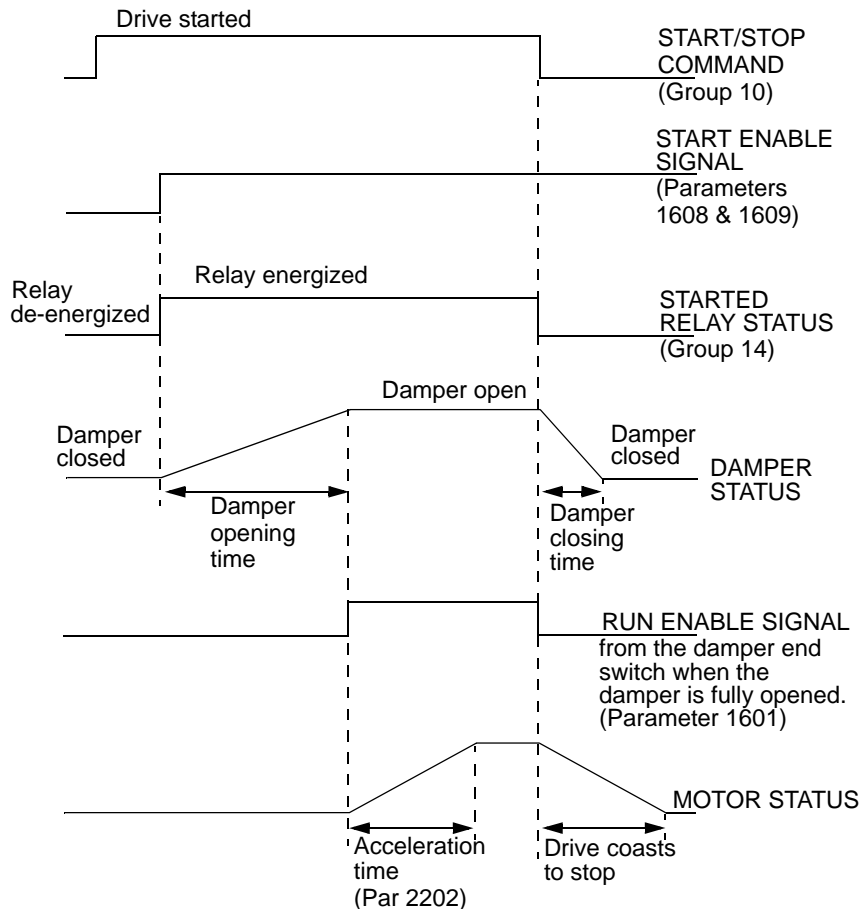

Code	Description
1609	<p>START ENABLE 2</p> <p>Selects the source of the start enable 2 signal.</p> <p>Note: Start enable functionality differs from the run enable functionality.</p> <p>0 = NOT SEL – Allows the drive to start without an external start enable signal.</p> <p>1 = DI1 – Defines digital input DI1 as the start enable 2 signal.</p> <ul style="list-style-type: none"> • This digital input must be activated for start enable 2 signal. • If the voltage drops and de-activates this digital input, the drive will coast to stop and show alarm 2022 on the panel display. The drive will not start until start enable 2 signal resumes. <p>2...6 = DI2...DI6 – Defines digital input DI2...DI6 as the start enable 2 signal.</p> <ul style="list-style-type: none"> • See DI1 above. <p>7 = COMM – Assigns the fieldbus Command Word as the source for the start enable 2 signal. Bit 3 of the Command word 2 (parameter 0302) activates the start enable 2 signal.</p> <ul style="list-style-type: none"> • See fieldbus user's manual for detailed instructions. <p>-1 = DI1(INV) – Defines an inverted digital input DI1 as the start enable 2 signal.</p> <p>-2...-6 = DI2(INV)...DI6(INV) – Defines an inverted digital input DI2...DI6 as the start enable 2 signal.</p> <ul style="list-style-type: none"> • See DI1 (INV) above.
1610	<p>DISPLAY ALARMS</p> <p>Controls the visibility of the following alarms:</p> <ul style="list-style-type: none"> • 2001, Overcurrent alarm • 2002, Overvoltage alarm • 2003, Undervoltage alarm • 2009, Device overtemperature alarm. <p>For more information, see section Alarm listing on page 258.</p> <p>0 = NO – The above alarms are suppressed.</p> <p>1 = YES – All of the above alarms are enabled.</p>
1612	<p>FAN CONTROL</p> <p>Selects drive cooling fan control. Can be used to mitigate DC voltage fluctuations.</p> <p>0 = AUTO – Fan is controlled automatically (default).</p> <p>1 = ON – Fan is always forced on.</p>
1613	<p>FAULT RESET</p> <p>Allows to reset faults with a parameter. Can be used to reset faults from remote monitoring systems that have access to drive parameters.</p> <p>0 = DEFAULT – Fault is not reset (default).</p> <p>1 = RESET NOW – Resets fault.</p>

Group 20: LIMITS

This group defines minimum and maximum limits to follow in driving the motor – speed, frequency, current, torque, etc.

Code	Description
2001	<p>MINIMUM SPEED Defines the minimum speed (rpm) allowed.</p> <ul style="list-style-type: none"> • A positive (or zero) minimum speed value defines two ranges, one positive and one negative. • A negative minimum speed value defines one speed range. • See the figure.
2002	<p>MAXIMUM SPEED Defines the maximum speed (rpm) allowed.</p>
2003	<p>MAX CURRENT Defines the maximum output current (A) supplied by the drive to the motor.</p>
2005	<p>OVERVOLT CTRL Sets the DC overvoltage controller on or off.</p> <ul style="list-style-type: none"> • Fast braking of a high inertia load causes the DC bus voltage to rise to the overvoltage control limit. To prevent the DC voltage from exceeding the trip limit, the overvoltage controller automatically decreases the braking torque by increasing output frequency. <p>0 = DISABLE – Disables controller. 1 = ENABLE – Enables controller</p> <p>Note: If a braking chopper or a braking resistor is connected to the drive, this parameter value must be set to 0 (DISABLE) to ensure proper operation of the chopper.</p>
2006	<p>UNDERVOLT CTRL Sets the DC undervoltage controller on or off. When on:</p> <ul style="list-style-type: none"> • If the DC bus voltage drops due to loss of input power, the undervoltage controller decreases the motor speed in order to keep the DC bus voltage above the lower limit. • When the motor speed decreases, the inertia of the load causes regeneration back into the drive, keeping the DC bus charged and preventing an undervoltage trip. • The DC undervoltage controller increases power loss ride-through on systems with a high inertia, such as a centrifuge or a fan. <p>0 = DISABLE – Disables controller. 1 = ENABLE(TIME) – Enables controller with 500 ms time limit for operation. 2 = ENABLE – Enables controller without maximum time limit for operation.</p>

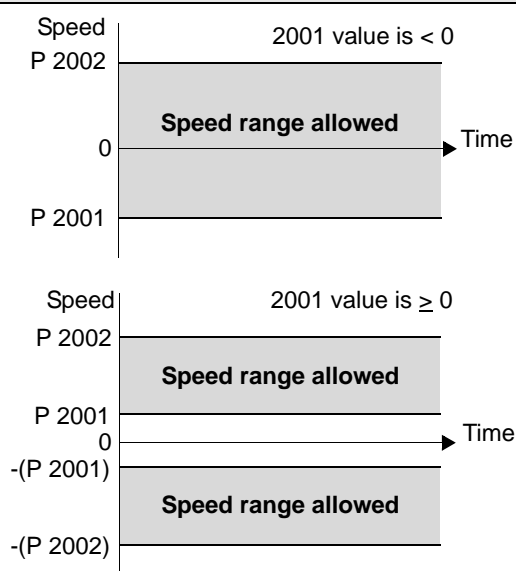

Code	Description	
2007	<p>MINIMUM FREQ</p> <p>Defines the minimum limit for the drive output frequency.</p> <ul style="list-style-type: none"> • A positive or zero minimum frequency value defines two ranges, one positive and one negative. • A negative minimum frequency value defines one speed range. <p>See the figure.</p> <p>Note: Keep $\text{MINIMUM FREQ} \leq \text{MAXIMUM FREQ}$.</p>	
2008	<p>MAXIMUM FREQ</p> <p>Defines the maximum limit for the drive output frequency.</p>	
2013	<p>MIN TORQUE SEL</p> <p>Defines control of the selection between two minimum torque limits (2015 MIN TORQUE 1 and 2016 MIN TORQUE 2).</p> <p>0 = MIN TORQUE 1 – Selects 2015 MIN TORQUE 1 as the minimum limit used.</p> <p>1 = DI1 – Defines digital input DI1 as the control for selecting the minimum limit used.</p> <ul style="list-style-type: none"> • Activating the digital input selects MIN TORQUE 2 value. • De-activating the digital input selects MIN TORQUE 1 value. <p>2...6 = DI2...DI6 – Defines digital input DI2...DI6 as the control for selecting the minimum limit used.</p> <ul style="list-style-type: none"> • See DI1 above. <p>7 = COMM – Defines bit 15 of the Command Word 1 as the control for selecting the minimum limit used.</p> <ul style="list-style-type: none"> • The Command Word is supplied through fieldbus communication. • The Command Word is parameter 0301. <p>-1 = DI1(INV) – Defines an inverted digital input DI1 as the control for selecting the minimum limit used.</p> <ul style="list-style-type: none"> • Activating the digital input selects MIN TORQUE 1 value. • De-activating the digital input selects MIN TORQUE 2 value. <p>-2...-6 = DI2(INV)...DI6(INV) – Defines an inverted digital input DI2...DI6 as the control for selecting the minimum limit used.</p> <ul style="list-style-type: none"> • See DI1(INV) above. 	
2014	<p>MAX TORQUE SEL</p> <p>Defines control of the selection between two maximum torque limits (2017 MAX TORQUE 1 and 2018 MAX TORQUE 2).</p> <p>0 = MAX TORQUE 1 – Selects 2017 MAX TORQUE 1 as the maximum limit used.</p> <p>1 = DI1 – Defines digital input DI1 as the control for selecting the maximum limit used.</p> <ul style="list-style-type: none"> • Activating the digital input selects MAX TORQUE 2 value. • De-activating the digital input selects MAX TORQUE 1 value. <p>2...6 = DI2...DI6 – Defines digital input DI2...DI6 as the control for selecting the maximum limit used.</p> <ul style="list-style-type: none"> • See DI1 above. <p>7 = COMM – Defines bit 15 of the Command Word 1 as the control for selecting the maximum limit used.</p> <ul style="list-style-type: none"> • The Command Word is supplied through fieldbus communication. • The Command Word is parameter 0301. <p>-1 = DI1(INV) – Defines an inverted digital input di1 as the control for selecting the maximum limit used.</p> <ul style="list-style-type: none"> • Activating the digital input selects MAX TORQUE 1 value. • De-activating the digital input selects MAX TORQUE 2 value. <p>-2...-6 = DI2(INV)...DI6(INV) – Defines an inverted digital input DI2...DI6 as the control for selecting the maximum limit used.</p> <ul style="list-style-type: none"> • See DI1(INV) above. 	
2015	<p>MIN TORQUE 1</p> <p>Sets the first minimum limit for torque (%). Value is a percent of the motor nominal torque.</p>	
2016	<p>MIN TORQUE 2</p> <p>Sets the second minimum limit for torque (%). Value is a percent of the motor nominal torque.</p>	

Code	Description
2017	MAX TORQUE 1 Sets the first maximum limit for torque (%). Value is a percent of the motor nominal torque.
2018	MAX TORQUE 2 Sets the second maximum limit for torque (%). Value is a percent of the motor nominal torque.

Group 21: START/STOP

This group defines how the motor starts and stops. The ACQ550 supports several start and stop modes.

Code	Description
2101	<p>START FUNCTION</p> <p>Selects the motor start method. The valid options depend on the value of parameter 9904 MOTOR CTRL MODE.</p> <p>1 = AUTO – Selects the automatic start mode.</p> <ul style="list-style-type: none"> • Vector control mode: Optimal start in most cases. The drive automatically selects the correct output frequency to start a rotating motor. • SCALAR:FREQ mode: Immediate start from zero frequency. Identical to selection 8 = RAMP. <p>2 = DC MAGN – Selects the DC Magnetizing start mode.</p> <p>Note: The DC Magnetizing start mode cannot start a rotating motor.</p> <p>Note: The drive starts when the set pre-magnetizing time (parameter 2103 DC MAGN TIME) has passed, even if motor magnetization is not complete.</p> <ul style="list-style-type: none"> • Vector control modes: Magnetizes the motor within the time determined by the parameter 2103 DC MAGN TIME using DC current. The normal control is released exactly after the magnetizing time. This selection guarantees the highest possible break-away torque. • SCALAR:FREQ mode: Magnetizes the motor within the time determined by the parameter 2103 DC MAGN TIME using DC current. The normal control is released exactly after the magnetizing time. <p>3 = SCALAR FLYST – Selects the flying start mode.</p> <ul style="list-style-type: none"> • Vector control modes: Not applicable. • SCALAR:FREQ mode: The drive automatically selects the correct output frequency to start a rotating motor – useful if the motor is already rotating and if the drive will start smoothly at the current frequency. • Cannot be used in multimotor systems. <p>4 = TORQ BOOST – Selects the automatic torque boost mode (SCALAR:FREQ mode only).</p> <ul style="list-style-type: none"> • May be necessary in drives with high starting torque. • Torque boost is only applied at start, ending when output frequency exceeds 20 Hz or when output frequency is equal to reference. • In the beginning the motor magnetizes within the time determined by the parameter 2103 DC MAGN TIME using DC current. • See parameter 2110 TORQ BOOST CURR. <p>5 = FLY + BOOST – Selects both the flying start and the torque boost mode (SCALAR:FREQ mode only).</p> <ul style="list-style-type: none"> • Flying start routine is performed first and the motor is magnetized. If the speed is found to be zero, the torque boost is done. <p>8 = RAMP – Immediate start from zero frequency.</p>
2102	<p>STOP FUNCTION</p> <p>Selects the motor stop method.</p> <p>1 = COAST – Selects cutting off the motor power as the stop method. The motor coasts to stop.</p> <p>2 = RAMP – Selects using a deceleration ramp.</p> <ul style="list-style-type: none"> • Deceleration ramp is defined by 2203 DECELER TIME 1 or 2206 DECELER TIME 2 (whichever is active).
2103	<p>DC MAGN TIME</p> <p>Defines the pre-magnetizing time for the DC Magnetizing start mode.</p> <ul style="list-style-type: none"> • Use parameter 2101 to select the start mode. • After the start command, the drive pre-magnetizes the motor for the time defined here and then starts the motor. • Set the pre-magnetizing time just long enough to allow full motor magnetization. Too long a time heats the motor excessively.
2104	<p>DC HOLD CTL</p> <p>Selects whether DC current is used for braking or DC Hold.</p> <p>0 = NOT SEL – Disables the DC current operation.</p> <p>1 = DC HOLD – Enables the DC Hold function. See the diagram.</p> <ul style="list-style-type: none"> • Requires parameter 9904 MOTOR CTRL MODE = 1 (VECTOR:SPEED) • Stops generating sinusoidal current and injects DC into the motor when both the reference and the motor speed drop below the value of parameter 2105. • When the reference rises above the level of parameter 2105 the drive resumes normal operation. <p>2 = DC BRAKING – Enables the DC Injection Braking after modulation has stopped.</p> <ul style="list-style-type: none"> • If parameter 2102 STOP FUNCTION is 1 (COAST), braking is applied after start is removed. • If parameter 2102 STOP FUNCTION is 2 (RAMP), braking is applied after ramp.

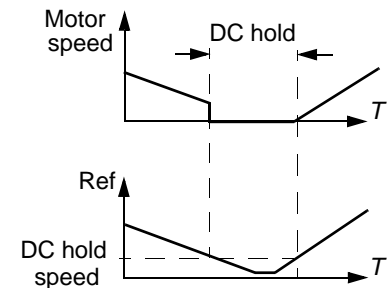

Code	Description
2105	<p>DC HOLD SPEED</p> <p>Sets the speed for DC Hold. Requires that parameter 2104 DC HOLD CTL = 1 (DC HOLD).</p>
2106	<p>DC CURR REF</p> <p>Defines the DC current control reference as a percentage of parameter 9906 MOTOR NOM CURR.</p>
2107	<p>DC BRAKE TIME</p> <p>Defines the DC brake time after modulation has stopped, if parameter 2104 is 2 (DC BRAKING).</p>
2108	<p>START INHIBIT</p> <p>Sets the Start inhibit function on or off. If the drive is not actively started and running, the Start inhibit function ignores a pending start command in any of the following situations and a new start command is required:</p> <ul style="list-style-type: none"> • A fault is reset. • Run Enable (parameter 1601) activates while start command is active. • Mode changes from local to remote. • Control switches from EXT1 to EXT2. • Control switches from EXT2 to EXT1. <p>0 = OFF – Disables the Start inhibit function. 1 = ON – Enables the Start inhibit function.</p>
2109	<p>EMERG STOP SEL</p> <p>Defines control of the Emergency stop command. When activated:</p> <ul style="list-style-type: none"> • Emergency stop decelerates the motor using the emergency stop ramp (parameter 2208 EMERG DEC TIME). • Requires an external stop command and removal of the emergency stop command before drive can restart. <p>0 = NOT SEL – Disables the Emergency stop function through digital inputs. 1 = DI1 – Defines digital input DI1 as the control for Emergency stop command.</p> <ul style="list-style-type: none"> • Activating the digital input issues an Emergency stop command. • De-activating the digital input removes the Emergency stop command. <p>2...6 = DI2...DI6 – Defines digital input DI2...DI6 as the control for Emergency stop command.</p> <ul style="list-style-type: none"> • See DI1 above. <p>-1 = DI1(INV) – Defines an inverted digital input DI1 as the control for Emergency stop command.</p> <ul style="list-style-type: none"> • De-activating the digital input issues an Emergency stop command. • Activating the digital input removes the Emergency stop command. <p>-2...-6 = DI2(INV)...DI6(INV) – Defines an inverted digital input DI2...DI6 as the control for Emergency stop command.</p> <ul style="list-style-type: none"> • See DI1(INV) above.
2110	<p>TORQ BOOST CURR</p> <p>Sets the maximum supplied current during torque boost.</p> <ul style="list-style-type: none"> • See parameter 2101 START FUNCTION.

Code	Description
2112	<p>ZERO SPEED DELAY</p> <p>Defines the delay for the Zero Speed Delay function. If parameter value is set to zero, the Zero Speed Delay function is disabled.</p> <p>The function is useful in applications where a smooth and quick restarting is essential. During the delay the drive knows accurately the rotor position.</p> <div style="display: flex; justify-content: space-around;"> <div data-bbox="332 373 755 630"> <p>No Zero Speed Delay</p> <p>Speed controller switched off: Motor coasts to stop.</p> </div> <div data-bbox="868 373 1380 661"> <p>With Zero Speed Delay</p> <p>Speed controller remains live. Motor is decelerated to true 0 speed.</p> </div> </div> <p>Zero speed delay can be used e.g. with jogging function or mechanical brake.</p> <p>No Zero Speed Delay</p> <p>The drive receives a stop command and decelerates along a ramp. When the motor actual speed falls below an internal limit (called Zero Speed), the speed controller is switched off. The drive modulation is stopped and the motor coasts to standstill.</p> <p>With Zero Speed Delay</p> <p>The drive receives a stop command and decelerates along a ramp. When the motor actual speed falls below an internal limit (called Zero Speed), the zero speed delay function activates. During the delay the functions keeps the speed controller live: The drive modulates, motor is magnetized and drive is ready for a quick restart.</p> <p>Note: Parameter 2102 STOP FUNCTION must be 2 = RAMP for zero speed delay to operate. 0.0 = NOT SEL – Disables the Zero Speed Delay function.</p>
2113	<p>START DELAY</p> <p>Defines the Start delay. After the conditions for start have been fulfilled, the drive waits until the delay has elapsed and then starts the motor. Start delay can be used with all start modes.</p> <ul style="list-style-type: none"> • If START DELAY = zero, the delay is disabled. • During the Start delay, alarm 2028 START DELAY is shown.

Group 22: ACCEL/DECEL

This group defines ramps that control the rate of acceleration and deceleration. You define these ramps as a pair, one for acceleration and one for deceleration. You can define two pairs of ramps and use a digital input to select one or the other pair.

Code	Description
2201	<p>ACC/DEC 1/2 SEL</p> <p>Defines control for selection of acceleration/deceleration ramps.</p> <ul style="list-style-type: none"> Ramps are defined in pairs, one each for acceleration and deceleration. See below for the ramp definition parameters. <p>0 = NOT SEL – Disables selection, the first ramp pair is used.</p> <p>1 = DI1 – Defines digital input DI1 as the control for ramp pair selection.</p> <ul style="list-style-type: none"> Activating the digital input selects ramp pair 2. De-activating the digital input selects ramp pair 1. <p>2...6 = DI2...DI6 – Defines digital input DI2...DI6 as the control for ramp pair selection.</p> <ul style="list-style-type: none"> See DI1 above. <p>7 = COMM – Defines bit 10 of the Command Word 1 as the control for ramp pair selection.</p> <ul style="list-style-type: none"> The Command Word is supplied through fieldbus communication. The Command Word is parameter 0301. <p>-1 = DI1(INV) – Defines an inverted digital input DI1 as the control for ramp pair selection.</p> <ul style="list-style-type: none"> De-activating the digital input selects ramp pair 2 Activating the digital input selects ramp pair 1. <p>-2...-6 = DI2(INV)...DI6(INV) – Defines an inverted digital input DI2...DI6 as the control for ramp pair selection.</p> <ul style="list-style-type: none"> See DI1(INV) above.
2202	<p>ACCELER TIME 1</p> <p>Sets the acceleration time for zero to maximum frequency for ramp pair 1. See A in the figure.</p> <ul style="list-style-type: none"> Actual acceleration time also depends on 2204 RAMP SHAPE 1. See 2008 MAXIMUM FREQ.
2203	<p>DECELER TIME 1</p> <p>Sets the deceleration time for maximum frequency to zero for ramp pair 1.</p> <ul style="list-style-type: none"> Actual deceleration time also depends on 2204 RAMP SHAPE 1. See 2008 MAXIMUM FREQ.
2204	<p>RAMP SHAPE 1</p> <p>Selects the shape of the acceleration/deceleration ramp for ramp pair 1. See B in the figure.</p> <ul style="list-style-type: none"> Shape is defined as a ramp, unless additional time is specified here to reach the maximum frequency. A longer time provides a softer transition at each end of the slope. The shape becomes an s-curve. Rule of thumb: 1/5 is a suitable relation between the ramp shape time and the acceleration ramp time. <p>0.0 = LINEAR – Specifies linear acceleration/deceleration ramps for ramp pair 1.</p> <p>0.1...1000.0 = S-CURVE – Specifies s-curve acceleration/deceleration ramps for ramp pair 1.</p>
2205	<p>ACCELER TIME 2</p> <p>Sets the acceleration time for zero to maximum frequency for ramp pair 2.</p> <ul style="list-style-type: none"> See 2202 ACCELER TIME 1. Used also as jogging acceleration time. See 1004 JOGGING SEL.
2206	<p>DECELER TIME 2</p> <p>Sets the deceleration time for maximum frequency to zero for ramp pair 2.</p> <ul style="list-style-type: none"> See 2203 DECELER TIME 1. Used also as jogging deceleration time. See 1004 JOGGING SEL.
2207	<p>RAMP SHAPE 2</p> <p>Selects the shape of the acceleration/deceleration ramp for ramp pair 2.</p> <ul style="list-style-type: none"> See 2204 RAMP SHAPE 1.

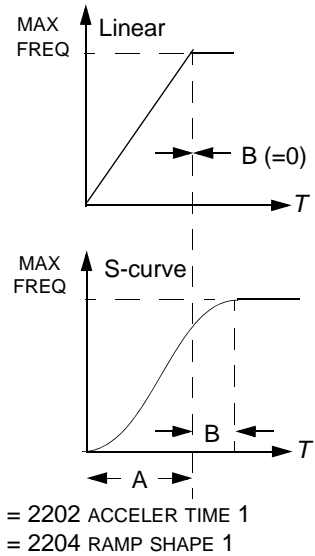

Code	Description
2208	<p>EMERG DEC TIME</p> <p>Sets the deceleration time for maximum frequency to zero for an emergency.</p> <ul style="list-style-type: none"> • See parameter 2109 EMERG STOP SEL. • Ramp is linear.
2209	<p>RAMP INPUT 0</p> <p>Defines control for forcing the speed to 0 with the currently used deceleration ramp (see parameters 2203 DECELER TIME 1 and 2206 DECELER TIME 2).</p> <p>0 = NOT SEL – Not selected.</p> <p>1 = DI1 – Defines digital input DI1 as the control for forcing the speed to 0.</p> <ul style="list-style-type: none"> • Activating the digital input forces the speed to zero, after which the speed will stay at 0. • De-activating the digital input: speed control resumes normal operation. <p>2...6 = DI2...DI6 – Defines digital input DI2...DI6 as the control for forcing the speed to 0.</p> <ul style="list-style-type: none"> • See DI1 above. <p>7 = COMM – Defines bit 13 of the Command Word 1 as the control for forcing the speed to 0.</p> <ul style="list-style-type: none"> • The Command Word is supplied through fieldbus communication. • The Command Word is parameter 0301. <p>-1 = DI1(INV) – Defines inverted digital input DI1 as the control for forcing the speed to 0.</p> <ul style="list-style-type: none"> • De-activating the digital input forces the speed to 0. • Activating the digital input: speed control resumes normal operation. <p>-2...-6 = DI2(INV)...DI6(INV) – Defines an inverted digital input DI2...DI6 as the control for forcing the speed to 0.</p> <ul style="list-style-type: none"> • See DI1(INV) above.

Group 23: SPEED CONTROL

This group defines variables used for speed control operation.

Code	Description
2301	<p>PROP GAIN</p> <p>Sets the relative gain for the speed controller.</p> <ul style="list-style-type: none"> • Larger values may cause speed oscillation. • The figure shows the speed controller output after an error step (error remains constant). <p>Note: You can use parameter 2305 AUTOTUNE RUN to automatically set the proportional gain.</p>
2302	<p>INTEGRATION TIME</p> <p>Sets the integration time for the speed controller.</p> <ul style="list-style-type: none"> • The integration time defines the rate at which the controller output changes for a constant error value. • Shorter integration times correct continuous errors faster. • Control becomes unstable if the integration time is too short. • The figure shows the speed controller output after an error step (error remains constant). <p>Note: You can use parameter 2305 AUTOTUNE RUN to automatically set the integration time.</p>
2303	<p>DERIVATION TIME</p> <p>Sets the derivation time for the speed controller.</p> <ul style="list-style-type: none"> • Derivative action makes the control more responsive to error value changes. • The longer the derivation time, the more the speed controller output is boosted during the change. • If the derivation time is set to zero, the controller works as a PI controller, otherwise as a PID controller. <p>The figure below shows the speed controller output after an error step when the error remains constant.</p>

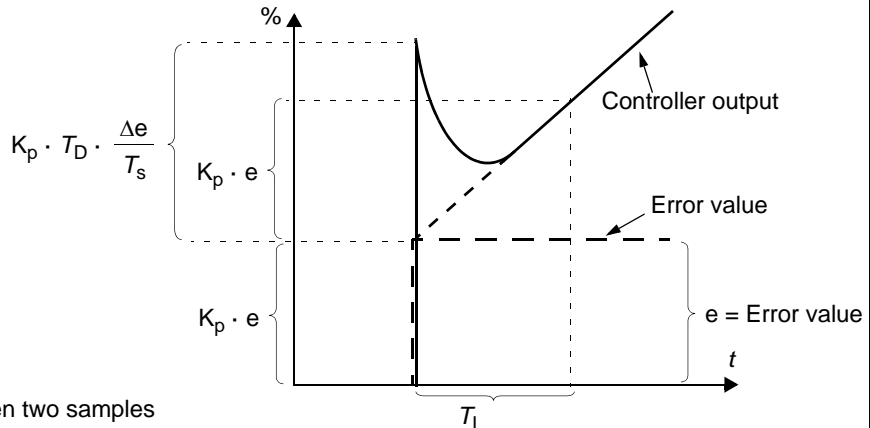
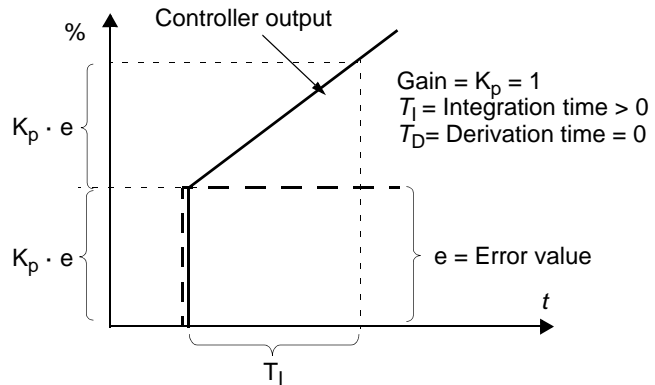
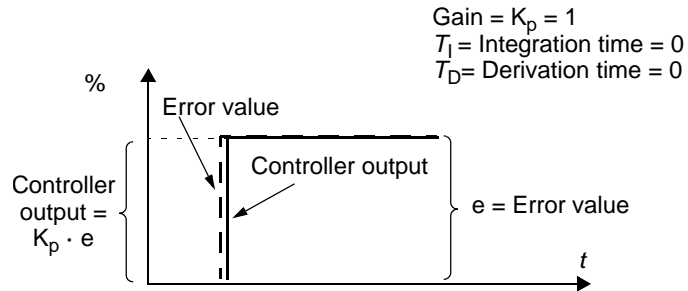

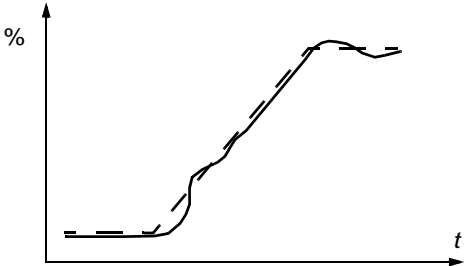
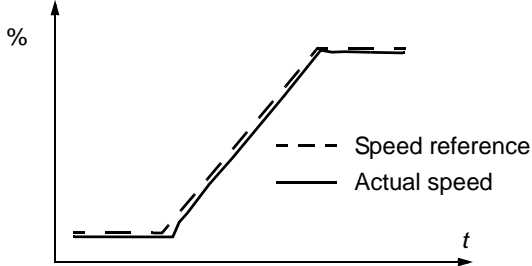
Code	Description
2304	<p>ACC COMPENSATION</p> <p>Sets the derivation time for acceleration compensation.</p> <ul style="list-style-type: none"> • Adding a derivative of the reference to the output of the speed controller compensates for inertia during acceleration. • 2303 DERIVATION TIME describes the principle of derivative action. • Rule of thumb: Set this parameter between 50 and 100% of the sum of the mechanical time constants for the motor and the driven machine. • The figure shows the speed responses when a high inertia load is accelerated along a ramp. <p>* No acceleration compensation</p>  <p>Acceleration compensation</p>  <p>*Note: You can use parameter 2305 AUTOTUNE RUN to automatically set acceleration compensation.</p>
2305	<p>AUTOTUNE RUN</p> <p>Starts automatic tuning of the speed controller.</p> <p>0 = OFF – Disables the Autotune creation process. (Does not disable the operation of Autotune settings.)</p> <p>1 = ON – Activates speed controller autotuning. Automatically reverts to OFF.</p> <p>Procedure:</p> <p>Note: The motor load must be connected.</p> <ul style="list-style-type: none"> • Run the motor at a constant speed of 20 to 40% of the rated speed. • Change the autotuning parameter 2305 to ON. <p>The drive:</p> <ul style="list-style-type: none"> • Accelerates the motor. • Calculates values for proportional gain, integration time and acceleration compensation. • Changes parameters 2301, 2302 and 2304 to these values. • Resets 2305 to OFF.

Group 25: CRITICAL SPEEDS

This group defines up to three critical speeds or ranges of speeds that are to be avoided due, for example, to mechanical resonance problems at certain speeds.

Code	Description
2501	<p>CRIT SPEED SEL</p> <p>Sets the critical speeds function on or off. The critical speed function avoids specific speed ranges.</p> <p>0 = OFF – Disables the critical speeds function. 1 = ON – Enables the critical speeds function.</p> <p>Example: To avoid speeds at which a fan system vibrates badly:</p> <ul style="list-style-type: none"> • Determine problem speed ranges. Assume they are found to be: 18...23 Hz and 46...52 Hz. • Set 2501 CRIT SPEED SEL = 1. • Set 2502 CRIT SPEED 1 LO = 18 Hz. • Set 2503 CRIT SPEED 1 HI = 23 Hz. • Set 2504 CRIT SPEED 2 LO = 46 Hz. • Set 2505 CRIT SPEED 2 HI = 52 Hz.
2502	<p>CRIT SPEED 1 LO</p> <p>Sets the minimum limit for critical speed range 1.</p> <ul style="list-style-type: none"> • The value must be less than or equal to 2503 CRIT SPEED 1 HI. • Units are rpm, unless 9904 MOTOR CTRL MODE = 3 (SCALAR:FREQ), then units are Hz.
2503	<p>CRIT SPEED 1 HI</p> <p>Sets the maximum limit for critical speed range 1.</p> <ul style="list-style-type: none"> • The value must be greater than or equal to 2502 CRIT SPEED 1 LO. • Units are rpm, unless 9904 MOTOR CTRL MODE = 3 (SCALAR:FREQ), then units are Hz.
2504	<p>CRIT SPEED 2 LO</p> <p>Sets the minimum limit for critical speed range 2.</p> <ul style="list-style-type: none"> • See parameter 2502.
2505	<p>CRIT SPEED 2 HI</p> <p>Sets the maximum limit for critical speed range 2.</p> <ul style="list-style-type: none"> • See parameter 2503.
2506	<p>CRIT SPEED 3 LO</p> <p>Sets the minimum limit for critical speed range 3.</p> <ul style="list-style-type: none"> • See parameter 2502.
2507	<p>CRIT SPEED 3 HI</p> <p>Sets the maximum limit for critical speed range 3.</p> <ul style="list-style-type: none"> • See parameter 2503.

Group 26: MOTOR CONTROL

This group defines variables used for motor control.

Code	Description																			
2601	<p>FLUX OPT ENABLE</p> <p>Changes the magnitude of the flux depending on the actual load. Flux Optimization can reduce the total energy consumption and noise, and it should be enabled for drives that usually operate below nominal load.</p> <p>0 = OFF – Disables the feature. 1 = ON – Enables the feature.</p>																			
2602	<p>FLUX BRAKING</p> <p>Provides faster deceleration by raising the level of magnetization in the motor when needed, instead of limiting the deceleration ramp. By increasing the flux in the motor, the energy of the mechanical system is changed to thermal energy in the motor.</p> <ul style="list-style-type: none"> Requires parameter 9904 MOTOR CTRL MODE = 1 or 2 (VECTOR:SPEED). <p>0 = OFF – Disables the feature. 1 = ON – Enables the feature.</p> <div style="display: flex; justify-content: space-between;"> <div style="width: 45%;"> </div> <div style="width: 45%;"> <p>Rated motor power</p> <ul style="list-style-type: none"> ① 2.2 kW ② 15 kW ③ 37 kW ④ 75 kW ⑤ 250 kW </div> </div> <div style="display: flex; justify-content: space-between;"> <div style="width: 45%;"> </div> <div style="width: 45%;"> <p>With flux braking</p> </div> </div>																			
2603	<p>IR COMP VOLT</p> <p>Sets the IR compensation voltage used for 0 Hz.</p> <ul style="list-style-type: none"> Requires parameter 9904 MOTOR CTRL MODE = 3 (SCALAR:FREQ). Keep IR compensation as low as possible to prevent overheating. Typical IR compensation values are: <table border="1" style="margin-left: 20px;"> <thead> <tr> <th colspan="6">380...480 V drives</th> </tr> <tr> <th>P_N (kW)</th> <td>3</td> <td>7.5</td> <td>15</td> <td>37</td> <td>132</td> </tr> <tr> <th>IR comp (V)</th> <td>18</td> <td>15</td> <td>12</td> <td>8</td> <td>3</td> </tr> </thead></table>	380...480 V drives						P_N (kW)	3	7.5	15	37	132	IR comp (V)	18	15	12	8	3	<p>IR compensation</p> <ul style="list-style-type: none"> When enabled, IR compensation provides an extra voltage boost to the motor at low speeds. Use IR compensation, for example, in applications that require a high breakaway torque. <div style="text-align: center;"> <p>A = IR compensated B = No compensation</p> </div>
380...480 V drives																				
P_N (kW)	3	7.5	15	37	132															
IR comp (V)	18	15	12	8	3															
2604	<p>IR COMP FREQ</p> <p>Sets the frequency at which IR compensation is 0 V (in % of motor frequency).</p>																			
2605	<p>U/F RATIO</p> <p>Selects the form for the U/f (voltage to frequency) ratio below field weakening point.</p> <p>1 = LINEAR – Preferred for constant torque applications. 2 = SQUARED – Preferred for centrifugal pump and fan applications. (SQUARED is more silent for most operating frequencies.)</p>																			

Code	Description												
2606	<p>SWITCHING FREQ</p> <p>Sets the switching frequency for the drive. Also see parameter 2607 SWITCH FREQ CTRL and section <i>Switching frequency derating</i> on page 270.</p> <ul style="list-style-type: none"> Higher switching frequencies mean less noise. 12 kHz switching frequency is available in scalar control mode, that is when parameter 9904 MOTOR CTRL MODE = 3 (SCALAR:FREQ). See the availability of switching frequencies for different drive types in the table below. <table border="1"> <thead> <tr> <th></th> <th>1, 2, 4 and 8 kHz</th> <th>12 kHz</th> </tr> </thead> <tbody> <tr> <td>208...240 V</td> <td>All types</td> <td>Frame sizes R1...R4 in scalar control mode</td> </tr> <tr> <td>380...480 V</td> <td>All types</td> <td>Frame sizes R1...R4 (except ACQ550-01-097A-4) in scalar control mode</td> </tr> <tr> <td>500...600 V</td> <td>All types</td> <td>Frame sizes R2...R4 in scalar control mode</td> </tr> </tbody> </table>		1, 2, 4 and 8 kHz	12 kHz	208...240 V	All types	Frame sizes R1...R4 in scalar control mode	380...480 V	All types	Frame sizes R1...R4 (except ACQ550-01-097A-4) in scalar control mode	500...600 V	All types	Frame sizes R2...R4 in scalar control mode
	1, 2, 4 and 8 kHz	12 kHz											
208...240 V	All types	Frame sizes R1...R4 in scalar control mode											
380...480 V	All types	Frame sizes R1...R4 (except ACQ550-01-097A-4) in scalar control mode											
500...600 V	All types	Frame sizes R2...R4 in scalar control mode											
2607	<p>SWITCH FREQ CTRL</p> <p>The switching frequency may be reduced if the ACQ550 internal temperature rises above a limit. See the figure. This function allows the highest possible switching frequency to be used based on operating conditions. Higher switching frequency results in lower acoustic noise.</p> <p>0 = OFF – The function is disabled. 1 = ON – The switching frequency is limited according to the figure.</p>												
2608	<p>SLIP COMP RATIO</p> <p>Sets gain for slip compensation (in %).</p> <ul style="list-style-type: none"> A squirrel-cage motor slips under load. Increasing the frequency as the motor torque increases compensates for the slip. Requires parameter 9904 MOTOR CTRL MODE = 3 (SCALAR:FREQ). <p>0 – No slip compensation. 1...200 – Increasing slip compensation. 100% means full slip compensation.</p>												
2609	<p>NOISE SMOOTHING</p> <p>This parameter introduces a random component to the switching frequency. Noise smoothing distributes the acoustic motor noise over a range of frequencies instead of a single tonal frequency resulting in lower peak noise intensity. The random component has an average of 0 Hz. It is added to the switching frequency set by parameter 2606 SWITCHING FREQ. This parameter has no effect if parameter 2606 = 12 kHz.</p> <p>0 = DISABLE 1 = ENABLE</p>												
2619	<p>DC STABILIZER</p> <p>Enables or disables the DC voltage stabilizer. The DC stabilizer is used in scalar control mode to prevent possible voltage oscillations in the drive DC bus caused by motor load or weak supply network. In case of voltage variation the drive tunes the frequency reference to stabilize the DC bus voltage and therefore the load torque oscillation.</p> <p>0 = DISABLE – Disables DC stabilizer. 1 = ENABLE – Enables DC stabilizer.</p>												
2625	<p>OVERMODULATION</p> <p>Enables or disables overmodulation. Disabling overmodulation can help in some applications in field weakening area.</p> <p>0 = DISABLE – Disables overmodulation (default). 1 = ENABLE – Enables overmodulation.</p>												
2627	<p>FLUX STAB GAIN</p> <p>Adjusts the flux stabilizer gain for scalar control.</p>												
2628	<p>DC STAB GAIN</p> <p>Adjusts the DC voltage stabilization.</p>												



Group 29: MAINTENANCE TRIG

This group contains usage levels and trigger points. When usage reaches the set trigger point, a notice displayed on the control panel signals that maintenance is due.

Code	Description
2901	<p>COOLING FAN TRIG</p> <p>Sets the trigger point for the drive's cooling fan counter.</p> <ul style="list-style-type: none"> Value is compared to parameter 2902 value. <p>0.0 – Disables the trigger.</p>
2902	<p>COOLING FAN ACT</p> <p>Defines the actual value of the drive's cooling fan counter.</p> <ul style="list-style-type: none"> When parameter 2901 has been set to a non-zero value, the counter starts. When the actual value of the counter exceeds the value defined by parameter 2901, a maintenance notice is displayed on the panel. <p>0.0 – Resets the parameter.</p>
2903	<p>REVOLUTION TRIG</p> <p>Sets the trigger point for the motor's accumulated revolutions counter.</p> <ul style="list-style-type: none"> Value is compared to parameter 2904 value. <p>0 – Disables the trigger.</p>
2904	<p>REVOLUTION ACT</p> <p>Defines the actual value of the motor's accumulated revolutions counter.</p> <ul style="list-style-type: none"> When parameter 2903 has been set to a non-zero value, the counter starts. When the actual value of the counter exceeds the value defined by parameter 2903, a maintenance notice is displayed on the panel. <p>0 – Resets the parameter.</p>
2905	<p>RUN TIME TRIG</p> <p>Sets the trigger point for the drive's run time counter.</p> <ul style="list-style-type: none"> Value is compared to parameter 2906 value. <p>0.0 – Disables the trigger.</p>
2906	<p>RUN TIME ACT</p> <p>Defines the actual value of the drive's run time counter.</p> <ul style="list-style-type: none"> When parameter 2905 has been set to a non-zero value, the counter starts. When the actual value of the counter exceeds the value defined by parameter 2905, a maintenance notice is displayed on the panel. <p>0.0 – Resets the parameter.</p>
2907	<p>USER MWh TRIG</p> <p>Sets the trigger point for the drive's accumulated power consumption (in megawatt hours) counter.</p> <ul style="list-style-type: none"> Value is compared to parameter 2908 value. <p>0.0 – Disables the trigger.</p>
2908	<p>USER MWh ACT</p> <p>Defines the actual value of the drive's accumulated power consumption (in megawatt hours) counter.</p> <ul style="list-style-type: none"> When parameter 2907 has been set to a non-zero value, the counter starts. When the actual value of the counter exceeds the value defined by parameter 2907, a maintenance notice is displayed on the panel. <p>0.0 – Resets the parameter.</p>

Group 30: FAULT FUNCTIONS

This group defines situations that the drive should recognize as potential faults and defines how the drive should respond if the fault is detected.

Code	Description
3001	<p>AI<MIN FUNCTION</p> <p>Defines the drive response if the analog input (AI) signal drops below the fault limits and AI is used</p> <ul style="list-style-type: none"> • as the active reference source (<i>Group 11: REFERENCE SELECT</i>) • as the Process or External PID controllers' feedback or setpoint source (<i>Group 40: PROCESS PID SET 1, Group 41: PROCESS PID SET 2</i> or <i>Group 42: EXT / TRIM PID</i>) and the corresponding PID controller is active. <p>3021 AI1 FAULT LIMIT and 3022 AI2 FAULT LIMIT set the fault limits.</p> <p>0 = NOT SEL – No response.</p> <p>1 = FAULT – Displays a fault (7, AI1 LOSS or 8, AI2 LOSS) and the drive coasts to stop.</p> <p>2 = CONST SP 7 – Displays an alarm (2006, AI1 LOSS or 2007, AI2 LOSS) and sets speed using 1208 CONST SPEED 7.</p> <p>3 = LAST SPEED – Displays an alarm (2006, AI1 LOSS or 2007, AI2 LOSS) and sets speed using the last operating level. This value is the average speed over the last 10 seconds.</p> <p> WARNING! If you select CONST SP 7 or LAST SPEED, make sure that continued operation is safe when the analog input signal is lost.</p>
3002	<p>PANEL COMM ERR</p> <p>Defines the drive response to a control panel communication error.</p> <p>1 = FAULT – Displays a fault (10, PANEL LOSS) and the drive coasts to stop.</p> <p>2 = CONST SP 7 – Displays an alarm (2008, PANEL LOSS) and sets speed using 1208 CONST SPEED 7.</p> <p>3 = LAST SPEED – Displays an alarm (2008, PANEL LOSS) and sets speed using the last operating level. This value is the average speed over the last 10 seconds.</p> <p>Note: When either of the two external control locations are active, and start, stop and/or direction are through the control panel – 1001 EXT1 COMMANDS / 1002 EXT2 COMMANDS = 8 (KEYPAD) – the drive follows speed/frequency reference according to the configuration of the external control locations, instead of the value of the last speed or parameter 1208 CONST SPEED 7.</p> <p> WARNING! If you select CONST SP 7 or LAST SPEED, make sure that continued operation is safe when the control panel communication is lost.</p>
3003	<p>EXTERNAL FAULT 1</p> <p>Defines the External Fault 1 signal input and the drive response to an external fault.</p> <p>0 = NOT SEL – External fault signal is not used.</p> <p>1 = DI1 – Defines digital input DI1 as the external fault input.</p> <ul style="list-style-type: none"> • Activating the digital input indicates a fault. The drive displays a fault (14, EXT FAULT 1) and the drive coasts to stop. <p>2...6 = DI2...DI6 – Defines digital input DI2...DI6 as the external fault input.</p> <ul style="list-style-type: none"> • See DI1 above. <p>-1 = DI1(INV) – Defines an inverted digital input DI1 as the external fault input.</p> <ul style="list-style-type: none"> • De-activating the digital input indicates a fault. The drive displays a fault (14, EXT FAULT 1) and the drive coasts to stop. <p>-2...-6 = DI2(INV)...DI6(INV) – Defines an inverted digital input DI2...DI6 as the external fault input.</p> <ul style="list-style-type: none"> • See DI1(INV) above.
3004	<p>EXTERNAL FAULT 2</p> <p>Defines the External Fault 2 signal input and the drive response to an external fault.</p> <ul style="list-style-type: none"> • See parameter 3003 above.
3005	<p>MOT THERM PROT</p> <p>Defines the drive response to motor overheating.</p> <p>0 = NOT SEL – No response and/or motor thermal protection not set up.</p> <p>1 = FAULT – When the calculated motor temperature exceeds 90 °C, displays an alarm (2010, MOTOR TEMP). When the calculated motor temperature exceeds 110 °C, displays a fault (9, MOT OVERTEMP) and the drive coasts to stop.</p> <p>2 = ALARM – When the calculated motor temperature exceeds 90 °C, displays an alarm (2010, MOTOR TEMP).</p>

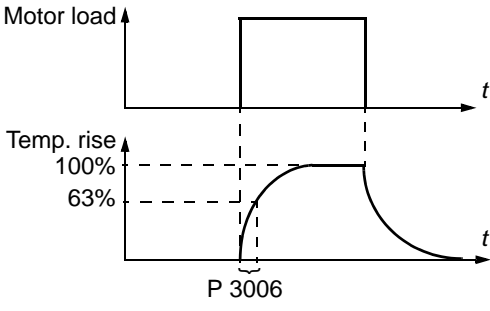
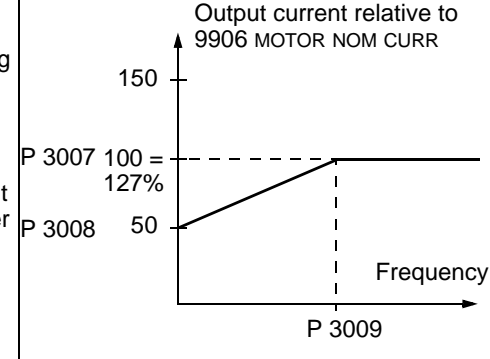
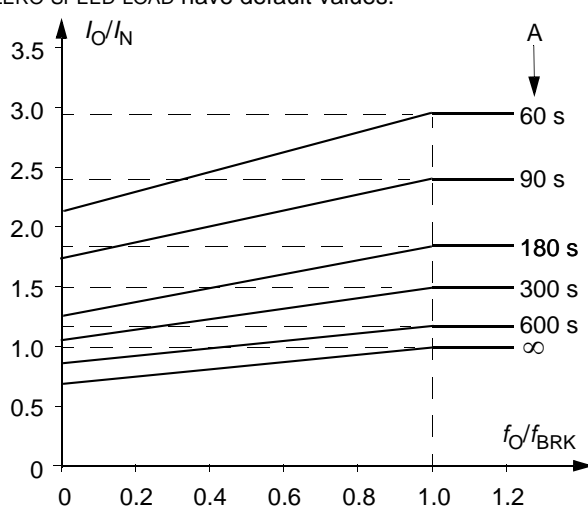
Code	Description
3006	<p>MOT THERM TIME</p> <p>Sets the motor thermal time constant for the motor temperature model.</p> <ul style="list-style-type: none"> • This is the time required for the motor to reach 63% of the final temperature with steady load. • For thermal protection according to UL requirements for NEMA class motors, use the rule of thumb: MOT THERM TIME equals 35 times t6, where t6 (in seconds) is specified by the motor manufacturer as the time that the motor can safely operate at six times its rated current. • The thermal time for a Class 10 trip curve is 350 s, for a Class 20 trip curve 700 s, and for a Class 30 trip curve 1050 s. 
3007	<p>MOT LOAD CURVE</p> <p>Sets the maximum allowable operating load of the motor.</p> <ul style="list-style-type: none"> • With the default value 100%, motor overload protection is functioning when the constant current exceeds 127% of the parameter 9906 MOTOR NOM CURR value. • The default overloadability is at the same level as what motor manufacturers typically allow below 30 °C (86 °F) ambient temperature and below 1000 m (3300 ft) altitude. When the ambient temperature exceeds 30 °C (86 °F) or the installation altitude is over 1000 m (3300 ft), decrease the parameter 3007 value according to the motor manufacturer's recommendation. <p>Example: If the constant protection level needs to be 115% of the motor nominal current, set parameter 3007 value to 91% (= 115/127·100%).</p> 
3008	<p>ZERO SPEED LOAD</p> <p>Sets the maximum allowable current at zero speed.</p> <ul style="list-style-type: none"> • Value is relative to 9906 MOTOR NOM CURR.
3009	<p>BREAK POINT FREQ</p> <p>Sets the break point frequency for the motor load curve.</p> <p>Example: Thermal protection trip times when parameters 3006 MOT THERM TIME, 3007 MOT LOAD CURVE and 3008 ZERO SPEED LOAD have default values.</p>  <p> I_O = Output current I_N = Nominal motor current f_O = Output frequency f_{BRK} = Break point frequency A = Trip time </p>

Code	Description
3010	<p>STALL FUNCTION</p> <p>This parameter defines the operation of the Stall function. This protection is active if the drive operates in the stall region (see the figure) for the time defined by 3012 STALL TIME. The "User Limit" is defined in Group 20: LIMITS by 2017 MAX TORQUE 1, 2018 MAX TORQUE 2, or the limit on the COMM input.</p> <p>0 = NOT SEL – Stall protection is not used.</p> <p>1 = FAULT – When the drive operates in the stall region for the time set by 3012 STALL TIME:</p> <ul style="list-style-type: none"> • The drive coasts to stop. • A fault indication is displayed. <p>2 = ALARM – When the drive operates in the stall region for the time set by 3012 STALL TIME:</p> <ul style="list-style-type: none"> • An alarm indication is displayed. • The alarm disappears when the drive is out of the stall region for half the time set by parameter 3012 STALL TIME.
3011	<p>STALL FREQUENCY</p> <p>This parameter sets the frequency value for the Stall function. Refer to the figure.</p>
3012	<p>STALL TIME</p> <p>This parameter sets the time value for the Stall function.</p>
3017	<p>EARTH FAULT</p> <p>Defines the drive response if the drive detects a ground fault in the motor or motor cables. The drive monitors for ground faults while the drive is running, and while the drive is not running. Also see parameter 3023 WIRING FAULT.</p> <p>0 = DISABLE – No drive response to ground faults.</p> <p>Note: Disabling earth fault (ground fault) may void the warranty.</p> <p>1 = ENABLE – Ground faults display fault 16 (EARTH FAULT), and (if running) the drive coasts to stop.</p>
3018	<p>COMM FAULT FUNC</p> <p>Defines the drive response if the fieldbus communication is lost.</p> <p>0 = NOT SEL – No response.</p> <p>1 = FAULT – Displays a fault (28, SERIAL 1 ERR) and the drive coasts to stop.</p> <p>2 = CONST SP 7 – Displays an alarm (2005, I/O COMM) and sets speed using 1208 CONST SPEED 7. This "alarm speed" remains active until the fieldbus writes a new reference value.</p> <p>3 = LAST SPEED – Displays an alarm (2005, I/O COMM) and sets speed using the last operating level. This value is the average speed over the last 10 seconds. This "alarm speed" remains active until the fieldbus writes a new reference value.</p> <p>WARNING! If you select CONST SP 7, or LAST SPEED, make sure that continued operation is safe when fieldbus communication is lost.</p>
3019	<p>COMM FAULT TIME</p> <p>Sets the communication fault time used with 3018 COMM FAULT FUNC.</p> <ul style="list-style-type: none"> • Brief interruptions in the fieldbus communication are not treated as faults if they are less than the COMM FAULT TIME value.
3021	<p>AI1 FAULT LIMIT</p> <p>Sets a fault level for analog input 1.</p> <ul style="list-style-type: none"> • See 3001 AI<MIN FUNCTION.
3022	<p>AI2 FAULT LIMIT</p> <p>Sets a fault level for analog input 2.</p> <ul style="list-style-type: none"> • See 3001 AI<MIN FUNCTION.

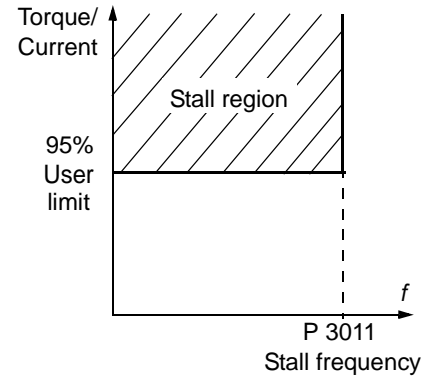

Code	Description
3023	<p>WIRING FAULT</p> <p>Defines the drive response to cross wiring faults and to ground faults detected when the drive is NOT running. When the drive is not running it monitors for:</p> <ul style="list-style-type: none"> • Improper connections of input power to the drive output (the drive can display fault 35, OUTPUT WIRING if improper connections are detected). • Ground faults (the drive can display fault 16, EARTH FAULT if a ground fault is detected). Also, see parameter 3017 EARTH FAULT. <p>0 = DISABLE – No drive response to either of the above monitoring results. Note: Disabling wiring fault (ground fault) may void the warranty. 1 = ENABLE – The drive displays faults when this monitoring detects problems.</p>
3024	<p>CB TEMP FAULT</p> <p>Defines the drive response to control board overheating.</p> <p>0 = DISABLE – No response. 1 = ENABLE – Displays fault 37 (CB OVERTEMP) and the drive coasts to stop.</p>
3028	<p>EARTH FAULT LVL</p> <p>Defines detection level for ground (earth) fault.</p> <p>Note: Parameter 3017 EARTH FAULT has to be enabled.</p> <p>1 = LOW – Lower level of ground (earth) current detected generates a fault (high sensitivity). Default setting. 2 = MEDIUM – Medium sensitivity to ground (earth) fault current. 3 = HIGH – Higher level of ground (earth) current detected generates a fault (low sensitivity).</p>

Group 31: AUTOMATIC RESET

This group defines conditions for automatic resets. An automatic reset occurs after a particular fault is detected. The drive holds for a set delay time, then automatically restarts. You can limit the number of resets in a specified time period and set up automatic resets for a variety of faults.

Code	Description
3101	<p>NUMBER OF TRIALS</p> <p>Sets the number of allowed automatic resets within a trial period defined by 3102 TRIAL TIME.</p> <ul style="list-style-type: none"> If the number of automatic resets exceeds this limit (within the trial time), the drive prevents additional automatic resets and remains stopped. Starting then requires a successful reset performed from the control panel or from a source selected by 1604 FAULT RESET SEL.
3102	<p>TRIAL TIME</p> <p>Sets the time period used for counting and limiting the number of resets.</p> <ul style="list-style-type: none"> See 3101 NUMBER OF TRIALS.
3103	<p>DELAY TIME</p> <p>Sets the delay time between a fault detection and attempted drive restart.</p> <ul style="list-style-type: none"> If DELAY TIME = zero, the drive resets immediately.
3104	<p>AR OVERCURRENT</p> <p>Sets the automatic reset for the overcurrent function on or off.</p> <p>0 = DISABLE – Disables automatic reset. 1 = ENABLE – Enables automatic reset.</p> <ul style="list-style-type: none"> Automatically resets the fault (OVERCURRENT) after the delay set by 3103 DELAY TIME, and the drive resumes normal operation.
3105	<p>AR OVERVOLTAGE</p> <p>Sets the automatic reset for the overvoltage function on or off.</p> <p>0 = DISABLE – Disables automatic reset. 1 = ENABLE – Enables automatic reset.</p> <ul style="list-style-type: none"> Automatically resets the fault (DC OVERVOLT) after the delay set by 3103 DELAY TIME, and the drive resumes normal operation.
3106	<p>AR UNDERVOLTAGE</p> <p>Sets the automatic reset for the undervoltage function on or off.</p> <p>0 = DISABLE – Disables automatic reset. 1 = ENABLE – Enables automatic reset.</p> <ul style="list-style-type: none"> Automatically resets the fault (DC UNDERVOLT) after the delay set by 3103 DELAY TIME, and the drive resumes normal operation.
3107	<p>AR AI<MIN</p> <p>Sets the automatic reset for the analog input less than minimum value function on or off.</p> <p>0 = DISABLE – Disables automatic reset. 1 = ENABLE – Enables automatic reset.</p> <ul style="list-style-type: none"> Automatically resets the fault (AI<MIN) after the delay set by 3103 DELAY TIME, and the drive resumes normal operation. <p> WARNING! When the analog input signal is restored, the drive may restart, even after a long stop. Make sure that automatic, long delayed starts will not cause physical injury and/or damage equipment.</p>
3108	<p>AR EXTERNAL FLT</p> <p>Sets the automatic reset for external faults function on or off.</p> <p>0 = DISABLE – Disables automatic reset. 1 = ENABLE – Enables automatic reset.</p> <ul style="list-style-type: none"> Automatically resets the fault (EXT FAULT 1 or EXT FAULT 2) after the delay set by 3103 DELAY TIME, and the drive resumes normal operation.

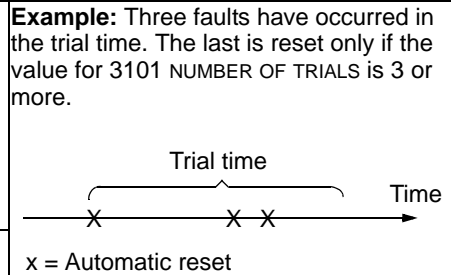

Group 32: SUPERVISION

This group defines supervision for up to three signals from *Group 01: OPERATING DATA*. Supervision monitors a specified parameter and energizes a relay output if the parameter passes a defined limit. Use *Group 14: RELAY OUTPUTS* to define the relay and whether the relay activates when the signal is too low or too high.

Code	Description
3201	<p>SUPERV 1 PARAM</p> <p>Selects the first supervised parameter.</p> <ul style="list-style-type: none"> Must be a parameter number from <i>Group 01: OPERATING DATA</i>. 100 = NOT SELECTED – No parameter selected. 101...178 – Selects parameter 0101...0178. If the supervised parameter passes a limit, a relay output is energized. The supervision limits are defined in this group. The relay outputs are defined in <i>Group 14: RELAY OUTPUTS</i> (definition also specifies which supervision limit is monitored). <p>LO ≤ HI</p> <p>Operating data supervision using relay outputs, when LO ≤ HI.</p> <ul style="list-style-type: none"> Case A = Parameter 1401 RELAY OUTPUT 1 (or 1402 RELAY OUTPUT 2, etc.) value is SUPRV1 OVER or SUPRV2 OVER. Use for monitoring when/if the supervised signal exceeds a given limit. The relay remains active until the supervised value drops below the low limit. Case B = Parameter 1401 RELAY OUTPUT 1 (or 1402 RELAY OUTPUT 2, etc.) value is SUPRV1 UNDER or SUPRV2 UNDER. Use for monitoring when/if the supervised signal falls below a given limit. The relay remains active until the supervised value rises above the high limit. <p>LO > HI</p> <p>Operating data supervision using relay outputs, when LO > HI. The lowest limit (HI 3203) is active initially and remains active until the supervised parameter goes above the highest limit (LO 3202), making that limit the active limit. That limit remains active until the supervised parameter goes below the lowest limit (HI 3203), making that limit active.</p> <ul style="list-style-type: none"> Case A = Parameter 1401 RELAY OUTPUT 1 (or 1402 RELAY OUTPUT 2, etc.) value is SUPRV1 OVER or SUPRV2 OVER. Initially the relay is de-energized. It is energized whenever the supervised parameter goes above the active limit. Case B = Parameter 1401 RELAY OUTPUT 1 (or 1402 RELAY OUTPUT 2, etc.) value is SUPRV1 UNDER or SUPRV2 UNDER. Initially the relay is energized. It is de-energized whenever the supervised parameter goes below the active limit.
3202	<p>SUPERV 1 LIM LO</p> <p>Sets the low limit for the first supervised parameter. See 3201 SUPERV 1 PARAM above.</p>
3203	<p>SUPERV 1 LIM HI</p> <p>Sets the high limit for the first supervised parameter. See 3201 SUPERV 1 PARAM above.</p>
3204	<p>SUPERV 2 PARAM</p> <p>Selects the second supervised parameter. See 3201 SUPERV 1 PARAM above.</p>
3205	<p>SUPERV 2 LIM LO</p> <p>Sets the low limit for the second supervised parameter. See 3204 SUPERV 2 PARAM above.</p>
3206	<p>SUPERV 2 LIM HI</p> <p>Sets the high limit for the second supervised parameter. See 3204 SUPERV 2 PARAM above.</p>

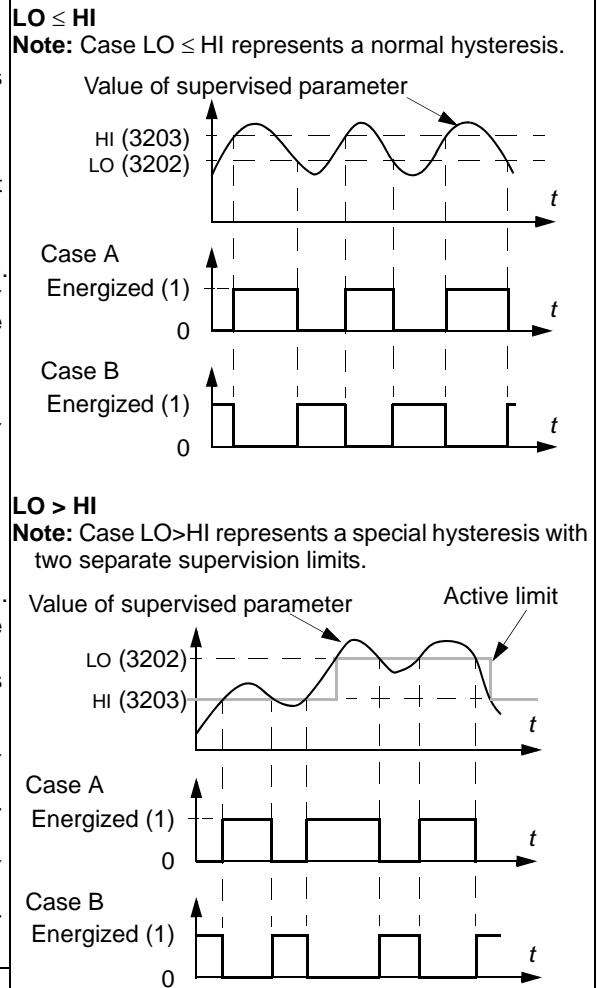

Code	Description
3207	SUPERV 3 PARAM Selects the third supervised parameter. See 3201 SUPERV 1 PARAM above.
3208	SUPERV 3 LIM LO Sets the low limit for the third supervised parameter. See 3207 SUPERV 3 PARAM above.
3209	SUPERV 3 LIM HI Sets the high limit for the third supervised parameter. See 3207 SUPERV 3 PARAM above.

Group 33: INFORMATION

This group provides access to information about the drive's current programs: versions and test date.

Code	Description
3301	FIRMWARE Contains the version of the drive's firmware.
3302	LOADING PACKAGE Contains the version of the loading package.
3303	TEST DATE Contains the test date (yy.ww).
3304	DRIVE RATING Indicates the drive's current and voltage rating. The format is XXXY, where: <ul style="list-style-type: none"> • XXX = The nominal current rating of the drive in amperes. If present, an "A" indicates a decimal point in the rating for the current. For example XXX = 8A8 indicates a nominal current rating of 8.8 A. • Y = The voltage rating of the drive, where Y = : <ul style="list-style-type: none"> • 2 indicates a 208...240 V rating. • 4 indicates a 380...480 V rating. • 6 indicates a 500...600 V rating.
3305	PARAMETER TABLE Contains the version of the parameter table used in the drive.

Group 34: PANEL DISPLAY

This group defines the content for control panel display (middle area), when the control panel is in the Output mode.

Code	Description																											
3401	<p>SIGNAL1 PARAM</p> <p>Selects the first parameter (by number) displayed on the control panel.</p> <ul style="list-style-type: none"> Definitions in this group define display content when the control panel is in the control mode. Any parameter number in Group 01: OPERATING DATA can be selected. Using the following parameters, the display value can be scaled, converted to convenient units and/or displayed as a bar graph. The figure identifies selections made by parameters in this group. If just one or two parameters are selected for display, that is just one or two of the values of parameters 3401 SIGNAL1 PARAM, 3408 SIGNAL2 PARAM and 3415 SIGNAL3 PARAM are other than 100 (NOT SELECTED), the number and name of each displayed parameter are shown in addition to the value. <p>100 = NOT SELECTED – First parameter not displayed. 101...178 – Displays parameter 0101...0178. If parameter does not exist, the display shows "n.a."</p>																											
3402	<p>SIGNAL1 MIN</p> <p>Defines the minimum expected value for the first display parameter. Use parameters 3402, 3403, 3406 and 3407, for example to convert a Group 01: OPERATING DATA parameter, such as 0102 SPEED (in rpm) to the speed of a conveyor driven by the motor (in ft/min). For such a conversion, the source values in the figure are the min. and max. motor speed, and the display values are the corresponding min. and max. conveyor speed. Use parameter 3405 to select the proper units for the display.</p> <p>Note: Selecting units does not convert values. Parameter is not effective if parameter 3404 OUTPUT1 DSP FORM = 9 (DIRECT).</p>																											
3403	<p>SIGNAL1 MAX</p> <p>Defines the maximum expected value for the first display parameter.</p> <p>Note: Parameter is not effective if parameter 3404 OUTPUT1 DSP FORM = 9 (DIRECT).</p>																											
3404	<p>OUTPUT1 DSP FORM</p> <p>Defines the decimal point location for the first display parameter.</p> <p>0...7 – Defines the decimal point location.</p> <ul style="list-style-type: none"> Enter the number of digits desired to the right of the decimal point. See the table for an example using pi (3.14159). <p>8 = BAR METER – Specifies a bar meter display.</p> <p>9 = DIRECT – Decimal point location and units of measure are identical to the source signal. See Group 01: OPERATING DATA parameter listing in section Complete parameter list on page 69 for resolution (which indicates the decimal point location) and the units of measure.</p> <table border="1" data-bbox="950 1312 1412 1701"> <thead> <tr> <th>3404 value</th> <th>Display</th> <th>Range</th> </tr> </thead> <tbody> <tr> <td>0</td> <td>± 3</td> <td rowspan="4">-32768...+32767 (Signed)</td> </tr> <tr> <td>1</td> <td>± 3.1</td> </tr> <tr> <td>2</td> <td>± 3.14</td> </tr> <tr> <td>3</td> <td>± 3.142</td> </tr> <tr> <td>4</td> <td>3</td> <td rowspan="4">0...65535 (Unsigned)</td> </tr> <tr> <td>5</td> <td>3.1</td> </tr> <tr> <td>6</td> <td>3.14</td> </tr> <tr> <td>7</td> <td>3.142</td> </tr> <tr> <td>8</td> <td colspan="2">Bar meter displayed.</td> </tr> <tr> <td>9</td> <td colspan="2">Decimal point location and units as for the source signal.</td> </tr> </tbody> </table>	3404 value	Display	Range	0	± 3	-32768...+32767 (Signed)	1	± 3.1	2	± 3.14	3	± 3.142	4	3	0...65535 (Unsigned)	5	3.1	6	3.14	7	3.142	8	Bar meter displayed.		9	Decimal point location and units as for the source signal.	
3404 value	Display	Range																										
0	± 3	-32768...+32767 (Signed)																										
1	± 3.1																											
2	± 3.14																											
3	± 3.142																											
4	3	0...65535 (Unsigned)																										
5	3.1																											
6	3.14																											
7	3.142																											
8	Bar meter displayed.																											
9	Decimal point location and units as for the source signal.																											

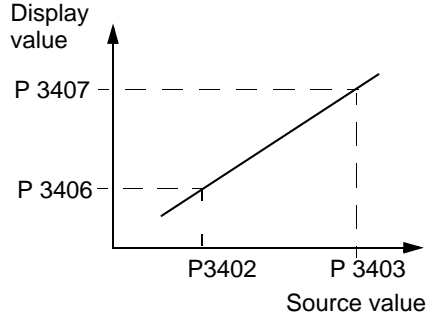
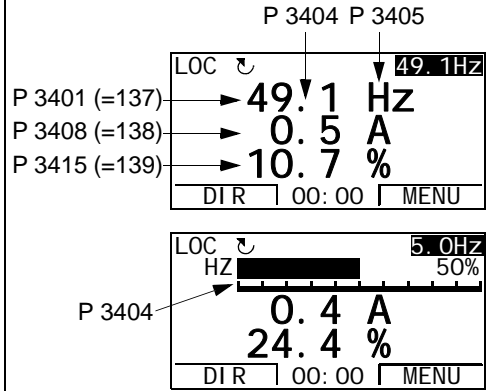

Code	Description																																																																																				
3405	<p>OUTPUT1 UNIT Selects the units used with the first display parameter. Note: Parameter is not effective if parameter 3404 OUTPUT1 DSP FORM = 9 (DIRECT).</p> <table border="0"> <tr> <td>0 = NO UNIT</td> <td>9 = °C</td> <td>18 = MWh</td> <td>27 = ft</td> <td>36 = l/s</td> <td>45 = Pa</td> <td>54 = lb/m</td> <td>63 = Mrev</td> </tr> <tr> <td>1 = A</td> <td>10 = lb ft</td> <td>19 = m/s</td> <td>28 = MGD</td> <td>37 = l/min</td> <td>46 = GPS</td> <td>55 = lb/h</td> <td>64 = d</td> </tr> <tr> <td>2 = V</td> <td>11 = mA</td> <td>20 = m³/h</td> <td>29 = inHg</td> <td>38 = l/h</td> <td>47 = gal/s</td> <td>56 = FPS</td> <td>65 = inWC</td> </tr> <tr> <td>3 = Hz</td> <td>12 = mV</td> <td>21 = dm³/s</td> <td>30 = FPM</td> <td>39 = m³/s</td> <td>48 = gal/m</td> <td>57 = ft/s</td> <td>66 = m/min</td> </tr> <tr> <td>4 = %</td> <td>13 = kW</td> <td>22 = bar</td> <td>31 = kb/s</td> <td>40 = m³/m</td> <td>49 = gal/h</td> <td>58 = inH₂O</td> <td>67 = Nm</td> </tr> <tr> <td>5 = s</td> <td>14 = W</td> <td>23 = kPa</td> <td>32 = kHz</td> <td>41 = kg/s</td> <td>50 = ft³/s</td> <td>59 = in wg</td> <td>68 = Km³/h</td> </tr> <tr> <td>6 = h</td> <td>15 = kWh</td> <td>24 = GPM</td> <td>33 = ohm</td> <td>42 = kg/m</td> <td>51 = ft³/m</td> <td>60 = ft wg</td> <td></td> </tr> <tr> <td>7 = rpm</td> <td>16 = °F</td> <td>25 = PSI</td> <td>34 = ppm</td> <td>43 = kg/h</td> <td>52 = ft³/h</td> <td>61 = lbsi</td> <td></td> </tr> <tr> <td>8 = kh</td> <td>17 = hp</td> <td>26 = CFM</td> <td>35 = pps</td> <td>44 = mbar</td> <td>53 = lb/s</td> <td>62 = ms</td> <td></td> </tr> </table> <p>The following units are useful for the bar display.</p> <table border="0"> <tr> <td>117 = %ref</td> <td>119 = %dev</td> <td>121 = % SP</td> <td>123 = Iout</td> <td>125 = Fout</td> <td>127 = Vdc</td> </tr> <tr> <td>118 = %act</td> <td>120 = % LD</td> <td>122 = %FBK</td> <td>124 = Vout</td> <td>126 = Tout</td> <td></td> </tr> </table>	0 = NO UNIT	9 = °C	18 = MWh	27 = ft	36 = l/s	45 = Pa	54 = lb/m	63 = Mrev	1 = A	10 = lb ft	19 = m/s	28 = MGD	37 = l/min	46 = GPS	55 = lb/h	64 = d	2 = V	11 = mA	20 = m ³ /h	29 = inHg	38 = l/h	47 = gal/s	56 = FPS	65 = inWC	3 = Hz	12 = mV	21 = dm ³ /s	30 = FPM	39 = m ³ /s	48 = gal/m	57 = ft/s	66 = m/min	4 = %	13 = kW	22 = bar	31 = kb/s	40 = m ³ /m	49 = gal/h	58 = inH ₂ O	67 = Nm	5 = s	14 = W	23 = kPa	32 = kHz	41 = kg/s	50 = ft ³ /s	59 = in wg	68 = Km ³ /h	6 = h	15 = kWh	24 = GPM	33 = ohm	42 = kg/m	51 = ft ³ /m	60 = ft wg		7 = rpm	16 = °F	25 = PSI	34 = ppm	43 = kg/h	52 = ft ³ /h	61 = lbsi		8 = kh	17 = hp	26 = CFM	35 = pps	44 = mbar	53 = lb/s	62 = ms		117 = %ref	119 = %dev	121 = % SP	123 = Iout	125 = Fout	127 = Vdc	118 = %act	120 = % LD	122 = %FBK	124 = Vout	126 = Tout	
0 = NO UNIT	9 = °C	18 = MWh	27 = ft	36 = l/s	45 = Pa	54 = lb/m	63 = Mrev																																																																														
1 = A	10 = lb ft	19 = m/s	28 = MGD	37 = l/min	46 = GPS	55 = lb/h	64 = d																																																																														
2 = V	11 = mA	20 = m ³ /h	29 = inHg	38 = l/h	47 = gal/s	56 = FPS	65 = inWC																																																																														
3 = Hz	12 = mV	21 = dm ³ /s	30 = FPM	39 = m ³ /s	48 = gal/m	57 = ft/s	66 = m/min																																																																														
4 = %	13 = kW	22 = bar	31 = kb/s	40 = m ³ /m	49 = gal/h	58 = inH ₂ O	67 = Nm																																																																														
5 = s	14 = W	23 = kPa	32 = kHz	41 = kg/s	50 = ft ³ /s	59 = in wg	68 = Km ³ /h																																																																														
6 = h	15 = kWh	24 = GPM	33 = ohm	42 = kg/m	51 = ft ³ /m	60 = ft wg																																																																															
7 = rpm	16 = °F	25 = PSI	34 = ppm	43 = kg/h	52 = ft ³ /h	61 = lbsi																																																																															
8 = kh	17 = hp	26 = CFM	35 = pps	44 = mbar	53 = lb/s	62 = ms																																																																															
117 = %ref	119 = %dev	121 = % SP	123 = Iout	125 = Fout	127 = Vdc																																																																																
118 = %act	120 = % LD	122 = %FBK	124 = Vout	126 = Tout																																																																																	
3406	<p>OUTPUT1 MIN Sets the minimum value displayed for the first display parameter. Note: Parameter is not effective if parameter 3404 OUTPUT1 DSP FORM = 9 (DIRECT).</p>																																																																																				
3407	<p>OUTPUT1 MAX Sets the maximum value displayed for the first display parameter. Note: Parameter is not effective if parameter 3404 OUTPUT1 DSP FORM = 9 (DIRECT).</p>																																																																																				
3408	<p>SIGNAL2 PARAM Selects the second parameter (by number) displayed on the control panel. See parameter 3401.</p>																																																																																				
3409	<p>SIGNAL2 MIN Defines the minimum expected value for the second display parameter. See parameter 3402.</p>																																																																																				
3410	<p>SIGNAL2 MAX Defines the maximum expected value for the second display parameter. See parameter 3403.</p>																																																																																				
3411	<p>OUTPUT2 DSP FORM Defines the decimal point location for the second display parameter. See parameter 3404.</p>																																																																																				
3412	<p>OUTPUT2 UNIT Selects the units used with the second display parameter. See parameter 3405.</p>																																																																																				
3413	<p>OUTPUT2 MIN Sets the minimum value displayed for the second display parameter. See parameter 3406.</p>																																																																																				
3414	<p>OUTPUT2 MAX Sets the maximum value displayed for the second display parameter. See parameter 3407.</p>																																																																																				
3415	<p>SIGNAL3 PARAM Selects the third parameter (by number) displayed on the control panel. See parameter 3401.</p>																																																																																				
3416	<p>SIGNAL3 MIN Defines the minimum expected value for the third display parameter. See parameter 3402.</p>																																																																																				
3417	<p>SIGNAL3 MAX Defines the maximum expected value for the third display parameter. See parameter 3403.</p>																																																																																				
3418	<p>OUTPUT3 DSP FORM Defines the decimal point location for the third display parameter. See parameter 3404.</p>																																																																																				
3419	<p>OUTPUT3 UNIT Selects the units used with the third display parameter. See parameter 3405.</p>																																																																																				
3420	<p>OUTPUT3 MIN Sets the minimum value displayed for the third display parameter. See parameter 3406.</p>																																																																																				

Code	Description
3421	OUTPUT3 MAX Sets the maximum value displayed for the third display parameter. See parameter 3407.

Group 35: MOTOR TEMP MEAS

This group defines the detection and reporting for a particular potential fault – motor overheating, as detected by a temperature sensor. Typical connections are shown below.

One sensor

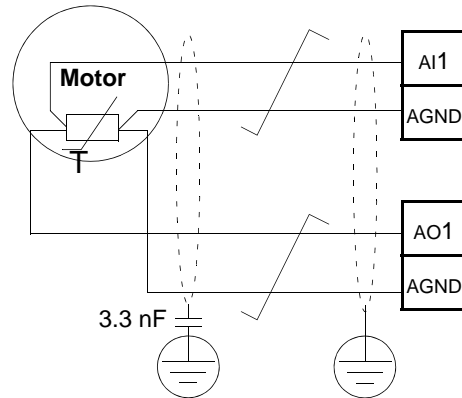

Three sensors

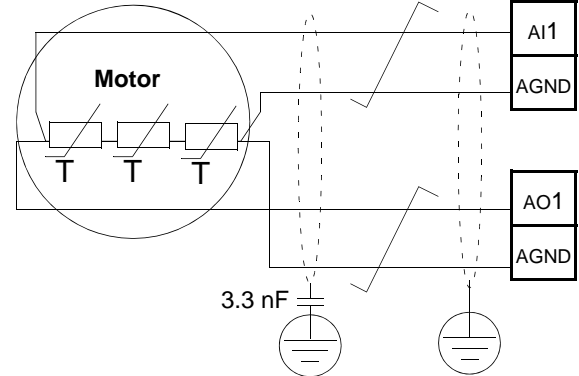

WARNING! IEC 60664 requires double or reinforced insulation between live parts and the surface of accessible parts of electrical equipment which are either non-conductive or conductive but not connected to the protective earth.

To fulfil this requirement, connect a thermistor (and other similar components) to the drive's control terminals using any of these alternatives:

- Separate the thermistor from live parts of the motor with double reinforced insulation.
- Protect all circuits connected to the drive's digital and analog inputs. Protect against contact, and insulate from other low voltage circuits with basic insulation (rated for the same voltage level as the drive's main circuit).
- Use an external thermistor relay. The relay insulation must be rated for the same voltage level as the drive's main circuit.

The figure below shows thermistor relay and PTC sensor connections using a digital input. At the motor end, the cable shield should be earthed through, eg a 3.3 nF capacitor. If this is not possible, leave the shield unconnected.

Thermistor relay

3501 SENSOR TYPE = 5 (THERM(0)) or 6 (THERM(1))

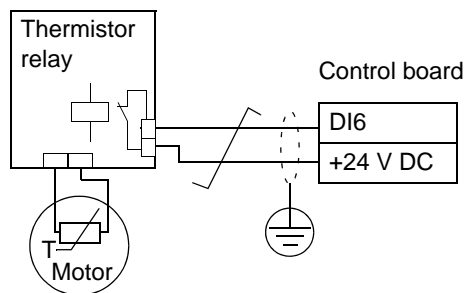

PTC sensor

3501 SENSOR TYPE = 5 (THERM(0))

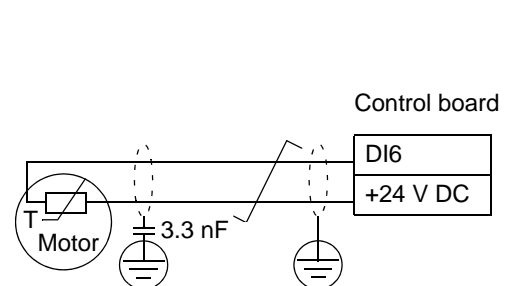

For other faults, or for anticipating motor overheating using a model, see [Group 30: FAULT FUNCTIONS](#).

Code	Description												
3501	<p>SENSOR TYPE</p> <p>Identifies the type of the motor temperature sensor used, PT100 (°C), PTC (ohm) or thermistor. See parameters 1501 AO1 CONTENT SEL and 1507 AO2 CONTENT SEL.</p> <p>0 = NONE</p> <p>1 = 1 x PT100 – Sensor configuration uses one PT100 sensor.</p> <ul style="list-style-type: none"> Analog output AO1 or AO2 feeds constant current through the sensor. The sensor resistance increases as the motor temperature rises, as does the voltage over the sensor. The temperature measurement function reads the voltage through analog input AI1 or AI2 and converts it to degrees Celsius. <p>2 = 2 x PT100 – Sensor configuration uses two PT100 sensors.</p> <ul style="list-style-type: none"> Operation is the same as for above 1 x PT100. <p>3 = 3 x PT100 – Sensor configuration uses three PT100 sensors.</p> <ul style="list-style-type: none"> Operation is the same as for above 1 x PT100. <p>4 = PTC – Sensor configuration uses one PTC.</p> <ul style="list-style-type: none"> The analog output feeds a constant current through the sensor. The resistance of the sensor increases sharply as the motor temperature rises over the PTC reference temperature (T_{ref}), as does the voltage over the resistor. The temperature measurement function reads the voltage through analog input AI1 and converts it into ohms. The table below and the graph show typical PTC sensor resistance as a function of the motor operating temperature. <table border="1"> <thead> <tr> <th>Temperature</th> <th>Resistance</th> </tr> </thead> <tbody> <tr> <td>Normal</td> <td>< 1.5 kohm</td> </tr> <tr> <td>Excessive</td> <td>> 4 kohm</td> </tr> </tbody> </table> <p>5 = THERM(0) – Sensor configuration uses a thermistor.</p> <ul style="list-style-type: none"> Motor thermal protection is activated through a digital input. Connect either a PTC sensor or a normally closed thermistor relay to a digital input. When the digital input is '0', the motor is overheated. See the connection figure on page 135. The table below and the graph show the resistance requirements for a PTC sensor connected between 24 V and a digital input as a function of the motor operating temperature. <table border="1"> <thead> <tr> <th>Temperature</th> <th>Resistance</th> </tr> </thead> <tbody> <tr> <td>Normal</td> <td>< 3 kohm</td> </tr> <tr> <td>Excessive</td> <td>> 28 kohm</td> </tr> </tbody> </table> <p>6 = THERM(1) – Sensor configuration uses a thermistor.</p> <ul style="list-style-type: none"> Motor thermal protection is activated through a digital input. Connect a normally open thermistor relay to a digital input. When the digital input is '1', the motor is overheated. See the connection figure on page 135. 	Temperature	Resistance	Normal	< 1.5 kohm	Excessive	> 4 kohm	Temperature	Resistance	Normal	< 3 kohm	Excessive	> 28 kohm
Temperature	Resistance												
Normal	< 1.5 kohm												
Excessive	> 4 kohm												
Temperature	Resistance												
Normal	< 3 kohm												
Excessive	> 28 kohm												
3502	<p>INPUT SELECTION</p> <p>Defines the input used for the temperature sensor.</p> <p>1 = AI1 – PT100 and PTC.</p> <p>2 = AI2 – PT100 and PTC.</p> <p>3...8 = DI1...DI6 – Thermistor and PTC</p>												
3503	<p>ALARM LIMIT</p> <p>Defines the alarm limit for motor temperature measurement.</p> <ul style="list-style-type: none"> At motor temperatures above this limit, the drive displays an alarm (2010, MOTOR TEMP) <p>For thermistors or PTC connected to a digital input:</p> <p>0 – de-activated</p> <p>1 – activated</p>												

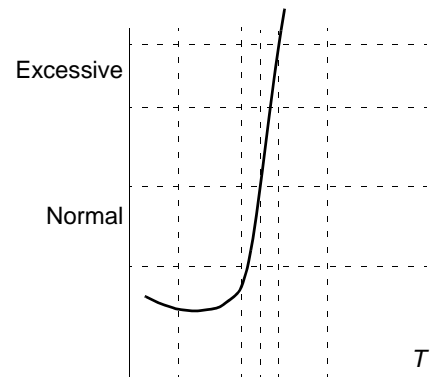

Code	Description
3504	FAULT LIMIT Defines the fault limit for motor temperature measurement. <ul style="list-style-type: none">• At motor temperatures above this limit, the drive displays a fault (9, MOT OVERTEMP) and stops the drive. For thermistors or PTC connected to a digital input: 0 – de-activated 1 – activated

Group 36: TIMED FUNCTIONS

This group defines the timed functions. The timed functions include:

- four daily start and stop times
- four weekly start, stop and boost times
- four timers for collecting selected periods together.

A timer can be connected to multiple time periods and a time period can be in multiple timers.

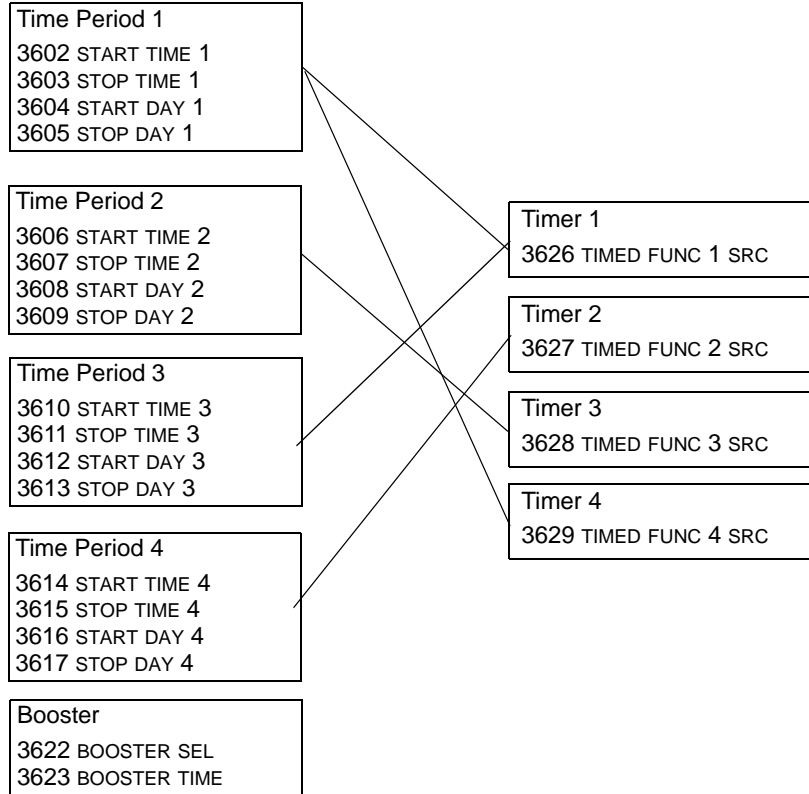

A parameter can be connected to only one timer.

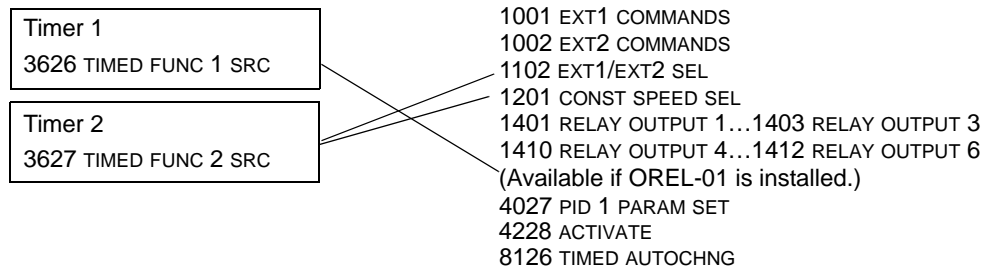

You can use the Timed functions assistant for easy configuring. For more information on the assistants, see section [Start-Up Assistant Mode](#) on page 47.

Code	Description
3601	<p>TIMERS ENABLE</p> <p>Selects the source for the timer enable signal.</p> <p>0 = NOT SEL – Timed functions are disabled.</p> <p>1 = DI1 – Defines digital input DI1 as the timed function enable signal.</p> <ul style="list-style-type: none"> The digital input must be activated to enable the timed function. <p>2...6 = DI2...DI6 – Defines digital input DI2...DI6 as the timed function enable signal.</p> <p>7 = ACTIVE – Timed functions are enabled.</p> <p>-1 = DI1(INV) – Defines an inverted digital input DI1 as the timed function enable signal.</p> <ul style="list-style-type: none"> This digital input must be de-activated to enable the timed function. -2...-6 = DI2(INV)...DI6(INV) – Defines an inverted digital input DI2...DI6 as the timed function enable signal.
3602	<p>START TIME 1</p> <p>Defines the daily start time. 20:30:00</p> <ul style="list-style-type: none"> The time can be changed in steps of 2 seconds. If parameter value is 07:00:00, the timer is activated at 7 a.m. The figure shows multiple timers on different weekdays. <p>17:00:00</p> <p>15:00:00</p> <p>13:00:00</p> <p>12:00:00</p> <p>10:30:00</p> <p>09:00:00</p> <p>00:00:00</p> <p>Time period 2</p> <p>Time period 4</p> <p>Time period 3</p> <p>Time period 1</p> <p>Mon Tue Wed Thu Fri Sat Sun</p>
3603	<p>STOP TIME 1</p> <p>Defines the daily stop time.</p> <ul style="list-style-type: none"> The time can be changed in steps of 2 seconds. If the parameter value is 09:00:00, the timer is deactivated at 9 a.m.
3604	<p>START DAY 1</p> <p>Defines the weekly start day.</p> <p>1 = MONDAY...7 = SUNDAY</p> <ul style="list-style-type: none"> If parameter value is 1, timer 1 weekly is active from Monday midnight (00:00:00).
3605	<p>STOP DAY 1</p> <p>Defines weekly stop day.</p> <p>1 = MONDAY...7 = SUNDAY</p> <ul style="list-style-type: none"> If parameter value is 5, timer 1 weekly is deactivated on Friday midnight (23:59:58).
3606	<p>START TIME 2</p> <p>Defines timer2 daily start time.</p> <ul style="list-style-type: none"> See parameter 3602.
3607	<p>STOP TIME 2</p> <p>Defines timer 2 daily stop time.</p> <ul style="list-style-type: none"> See parameter 3603.
3608	<p>START DAY 2</p> <p>Defines timer 2 weekly start day.</p> <ul style="list-style-type: none"> See parameter 3604.
3609	<p>STOP DAY 2</p> <p>Defines timer 2 weekly stop day.</p> <ul style="list-style-type: none"> See parameter 3605.
3610	<p>START TIME 3</p> <p>Defines timer 3 daily start time.</p> <ul style="list-style-type: none"> See parameter 3602.
3611	<p>STOP TIME 3</p> <p>Defines timer 3 daily stop time.</p> <ul style="list-style-type: none"> See parameter 3603.

Code	Description
3612	<p>START DAY 3 Defines timer 3 weekly start day. • See parameter 3604.</p>
3613	<p>STOP DAY 3 Defines timer 3 weekly stop day. • See parameter 3605.</p>
3614	<p>START TIME 4 Defines timer 4 daily start time. • See parameter 3602.</p>
3615	<p>STOP TIME 4 Defines timer 4 daily stop time. • See parameter 3603.</p>
3616	<p>START DAY 4 Defines timer 4 weekly start day. • See parameter 3604.</p>
3617	<p>STOP DAY 4 Defines timer 4 weekly stop day. • See parameter 3605.</p>
3622	<p>BOOSTER SEL Selects the source for the booster signal. 0 = NOT SEL – Booster signal is disabled. 1 = DI1 – Defines DI1 as the booster signal. 2...6 = DI2...DI6 – Defines DI2...DI6 as the booster signal. -1 = DI1(INV) – Defines an inverted digital input DI1 as the booster signal. -2...-6 = DI2(INV)...DI6(INV) – Defines an inverted digital input DI2...DI6 as the booster signal.</p>
3623	<p>BOOSTER TIME Defines the booster ON time. Time is started when booster sel signal is released. If parameter value is 01:30:00, booster is active for 1 hour and 30 minutes after activation DI is released.</p>
3626	<p>TIMED FUNC 1 SRC Defines the time periods used by the timer. 0 = NOT SEL – No time periods have been selected. 1 = T1 – Time Period 1 selected in the timer. 2 = T2 – Time Period 2 selected in the timer. 3 = T1+T2 – Time Periods 1 and 2 selected in the timer. 4 = T3 – Time Period 3 selected in the timer. 5 = T1+T3 – Time Periods 1 and 3 selected in the timer. 6 = T2+T3 – Time Periods 2 and 3 selected in the timer. 7 = T1+T2+T3 – Time Periods 1, 2 and 3 selected in the timer. 8 = T4 – Time Period 4 selected in the timer. 9 = T1+T4 – Time Periods 1 and 4 selected in the timer. 10 = T2+T4 – Time Periods 2 and 4 selected in the timer. 11 = T1+T2+T4 – Time Periods 1, 2 and 4 selected in the timer. 12 = T3+T4 – Time Periods 3 and 4 selected in the timer. 13 = T1+T3+T4 – Time Periods 1, 3 and 4 selected in the timer. 14 = T2+T3+T4 – Time Periods 2, 3 and 4 selected in the timer. 15 = T1+T2+T3+T4 – Time Periods 1, 2, 3 and 4 selected in the timer. 16 = BOOSTER – Booster selected in the timer. 17 = T1+B – Booster and Time Period 1 selected in the timer. 18 = T2+B – Booster and Time Period 2 selected in the timer. 19 = T1+T2+B – Booster and Time Periods 1 and 2 selected in the timer. 20 = T3+B – Booster and Time Period 3 selected in the timer.</p>

Code	Description
	21 = T1+T3+B – Booster and Time Periods 1 and 3 selected in the timer. 22 = T2+T3+B – Booster and Time Periods 2 and 3 selected in the timer. 23 = T1+T2+T3+B – Booster and Time Periods 1, 2 and 3 selected in the timer. 24 = T4+B – Booster and Time Period 4 selected in the timer. 25 = T1+T4+B – Booster and Time Periods 1 and 4 selected in the timer. 26 = T2+T4+B – Booster and Time Periods 2 and 4 selected in the timer. 27 = T1+T2+T4+B – Booster and Time Periods 1, 2 and 4 selected in the timer. 28 = T3+T4+B – Booster and Time Periods 3 and 4 selected in the timer. 29 = T1+T3+T4+B – Booster and Time Periods 1, 3 and 4 selected in the timer. 30 = T2+T3+T4+B – Booster and Time Periods 2, 3 and 4 selected in the timer. 31 = T1+2+3+4+B – Booster and Time Periods 1, 2, 3 and 4 selected in the timer.
3627	TIMED FUNC 2 SRC • See parameter 3626.
3628	TIMED FUNC 3 SRC • See parameter 3626.
3629	TIMED FUNC 4 SRC • See parameter 3626.

Group 37: USER LOAD CURVE

This group defines supervision of user adjustable load curves (motor torque as a function of frequency). The curve is defined by five points.

Code	Description
3701	<p>USER LOAD C MODE Supervision mode for the user adjustable load curves. This functionality replaces the former underload supervision in Group 30: FAULT FUNCTIONS. To emulate it, see section Correspondence with the obsolete underload supervision on page 143. 0 = NOT SEL – Supervision is not active. 1 = UNDERLOAD – Supervision for the torque dropping below the underload curve. 2 = OVERLOAD – Supervision for the torque exceeding the overload curve. 3 = BOTH – Supervision for the torque dropping below the underload curve or exceeding the overload curve.</p>
3702	<p>USER LOAD C FUNC Action wanted during load supervision. 1 = FAULT – A fault is generated when the condition defined by 3701 USER LOAD C MODE has been valid longer than the time set by 3703 USER LOAD C TIME. 2 = ALARM – An alarm is generated when the condition defined by 3701 USER LOAD C MODE has been valid longer than half of the time defined by 3703 USER LOAD C TIME.</p>
3703	<p>USER LOAD C TIME Defines the time limit for generating a fault. • Half of this time is used as the limit for generating an alarm.</p>
3704	<p>LOAD FREQ 1 Defines the frequency value of the first load curve definition point. • Must be smaller than 3707 LOAD FREQ 2.</p>
3705	<p>LOAD TORQ LOW 1 Defines the torque value of the first underload curve definition point. • Must be smaller than 3706 LOAD TORQ HIGH 1.</p>
3706	<p>LOAD TORQ HIGH 1 Defines the torque value of the first overload curve definition point.</p>
3707	<p>LOAD FREQ 2 Defines the frequency value of the second load curve definition point. • Must be smaller than 3710 LOAD FREQ 3.</p>
3708	<p>LOAD TORQ LOW 2 Defines the torque value of the second underload curve definition point. • Must be smaller than 3709 LOAD TORQ HIGH 2.</p>
3709	<p>LOAD TORQ HIGH 2 Defines the torque value of the second overload curve definition point.</p>
3710	<p>LOAD FREQ 3 Defines the frequency value of the third load curve definition point. • Must be smaller than 3713 LOAD FREQ 4.</p>
3711	<p>LOAD TORQ LOW 3 Defines the torque value of the third underload curve definition point. • Must be smaller than 3712 LOAD TORQ HIGH 3.</p>
3712	<p>LOAD TORQ HIGH 3 Defines the torque value of the third overload curve definition point.</p>

Code	Description
3713	LOAD FREQ 4 Defines the frequency value of the fourth load curve definition point. • Must be smaller than 3716 LOAD FREQ 5
3714	LOAD TORQ LOW 4 Defines the torque value of the fourth underload curve definition point. • Must be smaller than 3715 LOAD TORQ HIGH 4.
3715	LOAD TORQ HIGH 4 Defines the torque value of the fourth overload curve definition point.
3716	LOAD FREQ 5 Defines the frequency value of fifth load curve definition point.
3717	LOAD TORQ LOW 5 Defines the torque value of the fifth underload curve definition point. • Must be smaller than 3718 LOAD TORQ HIGH 5.
3718	LOAD TORQ HIGH 5 Defines the torque value of the fifth overload curve definition point.

Correspondence with the obsolete underload supervision

The now obsolete parameter 3015 UNDERLOAD CURVE provided five selectable curves shown in the figure. The parameter characteristics were as described below.

- If the load drops below the set curve for longer than the time set by parameter 3014 UNDERLOAD TIME (obsolete), the underload protection is activated.
- Curves 1...3 reach maximum at the motor rated frequency set by parameter 9907 MOTOR NOM FREQ.
- T_M = nominal torque of the motor.
- f_N = nominal frequency of the motor.

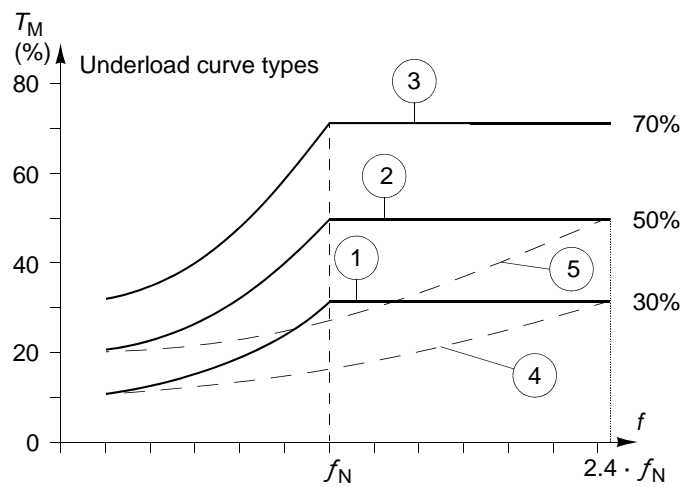

If you want to emulate the behavior of an old underload curve with parameters as in the shaded columns, set the new parameters as in the white columns in the two tables below:

Underload supervision with parameters 3013...3015 (obsolete)	Obsolete parameters		New parameters		
	3013 UNDERLOAD FUNCTION	3014 UNDERLOAD TIME	3701 USER LOAD C MODE	3702 USER LOAD C FUNC	3703 USER LOAD C TIME
No underload functionality	0	-	0	-	-
Underload curve, fault generated	1	t	1	1	t
Underload curve, alarm generated	2	t	1	2	2 · t

Obs. par.	New parameters														
	3704 LOAD FREQ 1 (Hz)		3705 LOAD TORQ LOW 1 (%)	3707 LOAD FREQ 2 (Hz)		3708 LOAD TORQ LOW 2 (%)	3710 LOAD FREQ 3 (Hz)		3711 LOAD TORQ LOW 3 (%)	3713 LOAD FREQ 4 (Hz)		3714 LOAD TORQ LOW 4 (%)	3716 LOAD FREQ 5 (Hz)		3717 LOAD TORQ LOW 5 (%)
	EU	US		EU	US		EU	US		EU	US		EU	US	
1	5	6	10	32	38	17	41	50	23	50	60	30	500	500	30
2	5	6	20	31	37	30	42	50	40	50	60	50	500	500	50
3	5	6	30	31	37	43	42	50	57	50	60	70	500	500	70
4	5	6	10	73	88	17	98	117	23	120	144	30	500	500	30
5	5	6	20	71	86	30	99	119	40	120	144	50	500	500	50

Group 40: PROCESS PID SET 1

This group defines a set of parameters used with the Process PID (PID1) controller. Typically only parameters in this group are needed.

PID controller – Basic set-up

In PID control mode, the drive compares a reference signal (setpoint) to an actual signal (feedback) and automatically adjusts the speed of the drive to match the two signals. The difference between the two signals is the error value.

Typically PID control mode is used, when the speed of a motor needs to be controlled based on pressure, flow or temperature. In most cases – when there is only 1 transducer signal wired to the ACQ550 – only parameter group 40 is needed.

The following is a schematic of setpoint/feedback signal flow using parameter group 40.

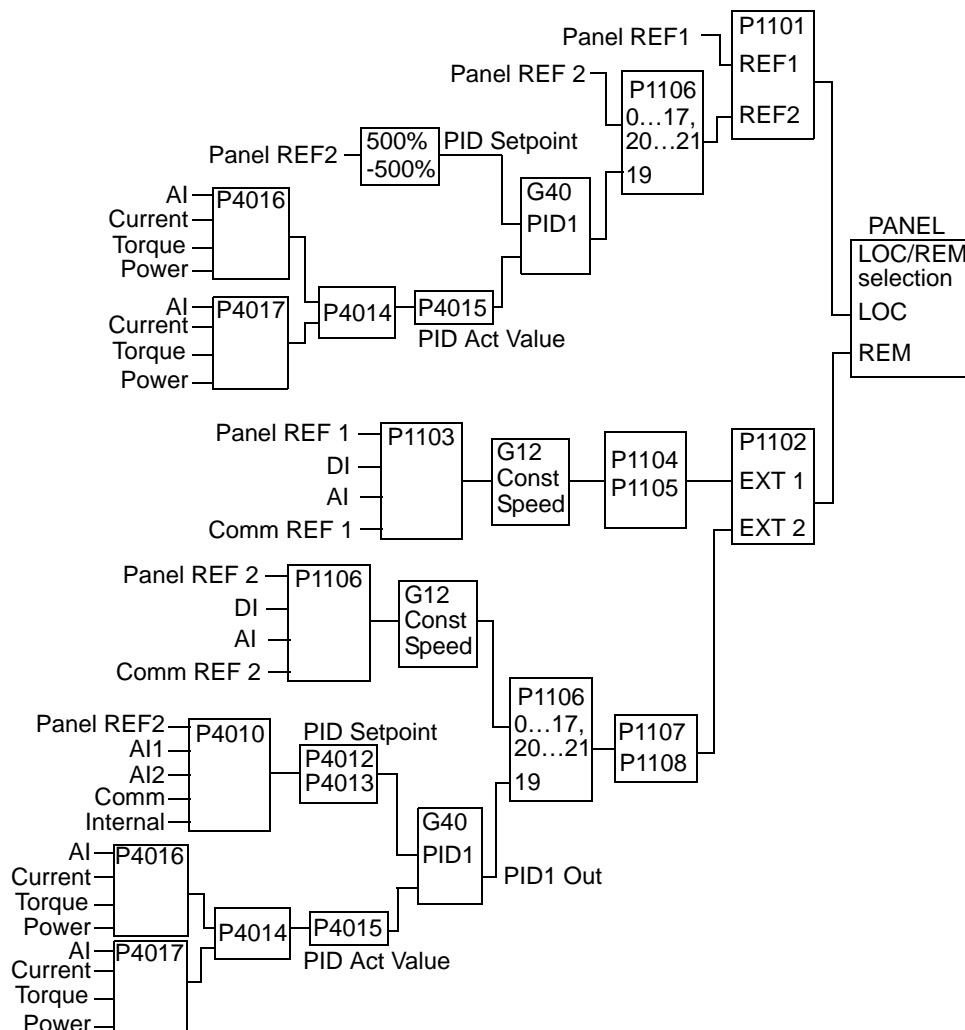

Note: In order to activate and use the PID controller, parameter 1106 must be set to value 19.

PID controller – Advanced

The ACQ550 has two separate PID controllers:

- Process PID (PID1) and
- External PID (PID2)

Process PID (PID1) has 2 separate sets of parameters:

- Process PID (PID1) SET1, defined in [Group 40: PROCESS PID SET 1](#) and
- Process PID (PID1) SET2, defined in [Group 41: PROCESS PID SET 2](#)

You can select between the two different sets by using parameter 4027.

Typically two different PID controller sets are used when the load of the motor changes considerably from one situation to another.

You can use External PID (PID2), defined in [Group 42: EXT / TRIM PID](#), in two different ways:

- Instead of using additional PID controller hardware, you can set outputs of the ACQ550 to control a field instrument like a damper or a valve. In this case, set parameter 4230 to value 0. (0 is the default value.)
- You can use External PID (PID2) to trim or fine-tune the speed of the ACQ550.

Code	Description
4001	<p>GAIN</p> <p>Defines the PID controller's gain.</p> <ul style="list-style-type: none"> • The setting range is 0.1... 100. • At 0.1, the PID controller output changes one-tenth as much as the error value. • At 100, the PID controller output changes one hundred times as much as the error value. <p>Use the proportional gain and integration time values to adjust the responsiveness of the system.</p> <ul style="list-style-type: none"> • A low value for proportional gain and a high value for integral time ensures stable operation, but provides sluggish response. <p>If the proportional gain value is too large or the integral time too short, the system can become unstable.</p> <p>Procedure:</p> <ul style="list-style-type: none"> • Initially, set: <ul style="list-style-type: none"> • 4001 GAIN = 0.1. • 4002 INTEGRATION TIME = 20 seconds. • Start the system and see if it reaches the setpoint quickly while maintaining stable operation. If not, increase GAIN (4001) until the actual signal (or drive speed) oscillates constantly. It may be necessary to start and stop the drive to induce this oscillation. • Reduce GAIN (4001) until the oscillation stops. • Set GAIN (4001) to 0.4 to 0.6 times the above value. • Decrease the INTEGRATION TIME (4002) until the feedback signal (or drive speed) oscillates constantly. It may be necessary to start and stop the drive to induce this oscillation. • Increase INTEGRATION TIME (4002) until the oscillation stops. • Set INTEGRATION TIME (4002) to 1.15 to 1.5 times the above value. • If the feedback signal contains high frequency noise, increase the value of parameter 1303 FILTER AI1 or 1306 FILTER AI2 until the noise is filtered from the signal.

Code	Description																		
4002	<p>INTEGRATION TIME</p> <p>Defines the PID controller's integration time.</p> <p>Integration time is, by definition, the time required to increase the output by the error value:</p> <ul style="list-style-type: none"> • Error value is constant and 100%. • Gain = 1. • Integration time of 1 second denotes that a 100% change is achieved in 1 second. <p>0.0 = NOT SEL – Disables integration (I-part of controller). 0.1...3600.0 – Integration time (seconds).</p> <ul style="list-style-type: none"> • See 4001 for adjustment procedure. 																		
	<p>A = Error B = Error value step C = Controller output with Gain = 1 D = Controller output with Gain = 10</p>																		
4003	<p>DERIVATION TIME</p> <p>Defines the PID controller's derivation time.</p> <ul style="list-style-type: none"> • You can add the derivative of the error to the PID controller output. The derivative is the error value's rate of change. For example, if the process error value changes linearly, the derivative is a constant added to the PID controller output. • The error-derivative is filtered with a 1-pole filter. The time constant of the filter is defined by parameter 4004 PID DERIV FILTER. <p>0.0...10.0 – Derivation time (seconds).</p>																		
	<p>Process error value 100% 0% PID output Gain P 4001 D-part of controller output P 4003</p>																		
4004	<p>PID DERIV FILTER</p> <p>Defines the filter time constant for the error-derivative part of the PID controller output.</p> <ul style="list-style-type: none"> • Before being added to the PID controller output, the error-derivative is filtered with a 1-pole filter. • Increasing the filter time smooths the error-derivative, reducing noise. <p>0.0...10.0 – Filter time constant (seconds).</p>																		
4005	<p>ERROR VALUE INV</p> <p>Selects either a normal or inverted relationship between the feedback signal and the drive speed.</p> <p>0 = NO – Normal, a decrease in feedback signal increases drive speed. Error = Ref - Fbk 1 = YES – Inverted, a decrease in feedback signal decreases drive speed. Error = Fbk - Ref</p>																		
4006	<p>UNITS</p> <p>Selects the unit for the PID controller actual values. (PID1 parameters 0128, 0130 and 0132).</p> <ul style="list-style-type: none"> • See parameter 3405 for list of available units. 																		
4007	<p>UNIT SCALE</p> <p>Defines the decimal point location in PID controller actual values.</p> <ul style="list-style-type: none"> • Enter the decimal point location counting in from the right end of the entry. • See the table for an example using pi (3.14159). <table border="1" style="float: right;"> <thead> <tr> <th>4007 value</th> <th>Entry</th> <th>Display</th> </tr> </thead> <tbody> <tr> <td>0</td> <td>00003</td> <td>3</td> </tr> <tr> <td>1</td> <td>00031</td> <td>3.1</td> </tr> <tr> <td>2</td> <td>00314</td> <td>3.14</td> </tr> <tr> <td>3</td> <td>03142</td> <td>3.142</td> </tr> <tr> <td>4</td> <td>31416</td> <td>3.1416</td> </tr> </tbody> </table>	4007 value	Entry	Display	0	00003	3	1	00031	3.1	2	00314	3.14	3	03142	3.142	4	31416	3.1416
4007 value	Entry	Display																	
0	00003	3																	
1	00031	3.1																	
2	00314	3.14																	
3	03142	3.142																	
4	31416	3.1416																	

Code	Description
4008	<p>0% VALUE</p> <p>Defines (together with the next parameter) the scaling applied to the PID controller's actual values (PID1 parameters 0128, 0130 and 0132).</p> <ul style="list-style-type: none"> Units and scale are defined by parameters 4006 and 4007.
4009	<p>100% VALUE</p> <p>Defines (together with the previous parameter) the scaling applied to the PID controller's actual values.</p> <ul style="list-style-type: none"> Units and scale are defined by parameters 4006 and 4007.
4010	<p>SET POINT SEL</p> <p>Defines the reference signal source for the PID controller.</p> <ul style="list-style-type: none"> Parameter has no significance when the PID regulator is by-passed (see 8121 REG BYPASS CTRL). <p>0 = KEYPAD – Control panel provides reference.</p> <p>1 = AI1 – Analog input 1 provides reference.</p> <p>2 = AI2 – Analog input 2 provides reference.</p> <p>8 = COMM – Fieldbus provides reference.</p> <p>9 = COMM+AI1 – Defines a fieldbus and analog input 1 (AI1) combination as the reference source. See Analog input reference correction below.</p> <p>10 = COMM*AI1 – Defines a fieldbus and analog input 1 (AI1) combination as the reference source. See Analog input reference correction below.</p> <p>11 = DI3U,4D(RNC) – Digital inputs, acting as a motor potentiometer control, provide reference.</p> <ul style="list-style-type: none"> DI3 increases the speed (the U stands for “up”) DI4 decreases the reference (the D stands for “down”). Parameter 2205 ACCELER TIME 2 controls the reference signal's rate of change. R = Stop command resets the reference to zero. NC = Reference value is not copied. <p>12 = DI3U,4D(NC) – Same as DI3U,4D(RNC) above, except:</p> <ul style="list-style-type: none"> Stop command does not reset reference to zero. At restart the motor ramps up, at the selected acceleration rate, to the stored reference. <p>13 = DI5U,6D(NC) – Same as DI3U,4D(NC) above, except:</p> <ul style="list-style-type: none"> Uses digital inputs DI5 and DI6. <p>14 = AI1+AI2 – Defines an analog input 1 (AI1) and analog input 2 (AI2) combination as the reference source. See Analog input reference correction below.</p> <p>15 = AI1*AI2 – Defines an analog input 1 (AI1) and analog input 2 (AI2) combination as the reference source. See Analog input reference correction below.</p> <p>16 = AI1-AI2 – Defines an analog input 1 (AI1) and analog input 2 (AI2) combination as the reference source. See Analog input reference correction below.</p> <p>17 = AI1/AI2 – Defines an analog input 1 (AI1) and analog input 2 (AI2) combination as the reference source. See Analog input reference correction below.</p> <p>19 = INTERNAL – A constant value set using parameter 4011 provides reference.</p> <p>20 = PID2OUT – Defines PID controller 2 output (parameter 0127 PID 2 OUTPUT) as the reference source.</p>

Code	Description										
	<p>Analog input reference correction Parameter values 9, 10 and 14...17 use the formula in the following table.</p> <table border="1"> <thead> <tr> <th>Value setting</th> <th>Calculation of the AI reference</th> </tr> </thead> <tbody> <tr> <td>C + B</td> <td>C value + (B value - 50% of reference value)</td> </tr> <tr> <td>C * B</td> <td>C value * (B value / 50% of reference value)</td> </tr> <tr> <td>C - B</td> <td>(C value + 50% of reference value) - B value</td> </tr> <tr> <td>C / B</td> <td>(C value * 50% of reference value) / B value</td> </tr> </tbody> </table> <p>Where:</p> <ul style="list-style-type: none"> C = Main reference value (= COMM for values 9, 10 and = AI1 for values 14...17) B = Correcting reference (= AI1 for values 9, 10 and = AI2 for values 14...17). <p>Example: The figure shows the reference source curves for value settings 9, 10 and 14...17, where:</p> <ul style="list-style-type: none"> C = 25%. P 4012 SETPOINT MIN = 0. P 4013 SETPOINT MAX = 0. B varies along the horizontal axis. 	Value setting	Calculation of the AI reference	C + B	C value + (B value - 50% of reference value)	C * B	C value * (B value / 50% of reference value)	C - B	(C value + 50% of reference value) - B value	C / B	(C value * 50% of reference value) / B value
Value setting	Calculation of the AI reference										
C + B	C value + (B value - 50% of reference value)										
C * B	C value * (B value / 50% of reference value)										
C - B	(C value + 50% of reference value) - B value										
C / B	(C value * 50% of reference value) / B value										
4011	<p>INTERNAL SETPNT Sets a constant value used for the process reference.</p> <ul style="list-style-type: none"> Units and scale are defined by parameters 4006 and 4007. 										
4012	<p>SETPOINT MIN Sets the minimum value for the reference signal source.</p> <ul style="list-style-type: none"> See parameter 4010. 										
4013	<p>SETPOINT MAX Sets the maximum value for the reference signal source.</p> <ul style="list-style-type: none"> See parameter 4010. 										
4014	<p>FBK SEL Defines the PID controller feedback (actual signal).</p> <ul style="list-style-type: none"> You can define a combination of two actual values (ACT1 and ACT2) as the feedback signal. Use parameter 4016 to define the source for actual value 1 (ACT1). Use parameter 4017 to define the source for actual value 2 (ACT2). 1 = ACT1 – Actual value 1 (ACT1) provides the feedback signal. 2 = ACT1-ACT2 – ACT1 minus ACT2 provides the feedback signal. 3 = ACT1+ACT2 – ACT1 plus ACT2 provides the feedback signal. 4 = ACT1*ACT2 – ACT1 times ACT2 provides the feedback signal. 5 = ACT1/ACT2 – ACT1 divided by ACT2 provides the feedback signal. 6 = MIN(ACT1,2) – The smaller of ACT1 or ACT2 provides the feedback signal. 7 = MAX(ACT1,2) – The greater of ACT1 or ACT2 provides the feedback signal. 8 = sqrt(ACT1-2) – Square root of the value for ACT1 minus ACT2 provides the feedback signal. 9 = sqA1+sqA2 – Square root of ACT1 plus the square root of ACT2 provides the feedback signal. 10 = sqrt(ACT1) – Square root of ACT1 provides the feedback signal. 11 = COMM FBK 1 – Signal 0158 PID COMM VALUE 1 provides the feedback signal. 12 = COMM FBK 2 – Signal 0159 PID COMM VALUE 2 provides the feedback signal. 13 = AVE(ACT1,2) – The average of ACT1 and ACT2 provides the feedback signal. 										
4015	<p>FBK MULTIPLIER Defines an extra multiplier for the PID feedback value FBK defined by parameter 4014.</p> <ul style="list-style-type: none"> Used mainly in applications where the flow is calculated from the pressure difference. 0.000 = NOT SEL – The parameter has no effect (1.000 used as the multiplier). -32.768...32.767 – Multiplier applied to the signal defined by parameter 4014 FBK SEL. <p>Example: FBK = Multiplier × $\sqrt{A1 - A2}$</p>										

Code	Description																								
4016	<p>ACT1 INPUT</p> <p>Defines the source for actual value 1 (ACT1). See also parameter 4018 ACT1 MINIMUM.</p> <p>1 = AI1 – Uses analog input 1 for ACT1. 2 = AI2 – Uses analog input 2 for ACT1. 3 = CURRENT – Uses current for ACT1. 4 = TORQUE – Uses torque for ACT1. 5 = POWER – Uses power for ACT1. 6 = COMM ACT 1 – Uses value of signal 0158 PID COMM VALUE 1 for ACT1. 7 = COMM ACT 2 – Uses value of signal 0159 PID COMM VALUE 2 for ACT1.</p>																								
4017	<p>ACT2 INPUT</p> <p>Defines the source for actual value 2 (ACT2). See also parameter 4020 ACT2 MINIMUM.</p> <p>1 = AI1 – Uses analog input 1 for ACT2. 2 = AI2 – Uses analog input 2 for ACT2. 3 = CURRENT – Uses current for ACT2. 4 = TORQUE – Uses torque for ACT2. 5 = POWER – Uses power for ACT2. 6 = COMM ACT 1 – Uses value of signal 0158 PID COMM VALUE 1 for ACT2. 7 = COMM ACT 2 – Uses value of signal 0159 PID COMM VALUE 2 for ACT2.</p>																								
4018	<p>ACT1 MINIMUM</p> <p>Sets the minimum value for ACT1.</p> <ul style="list-style-type: none"> • Scales the source signal used as the actual value ACT1 (defined by parameter 4016 ACT1 INPUT). For parameter 4016 values 6 (COMM ACT 1) and 7 (COMM ACT 2) scaling is not done. <table border="1"> <thead> <tr> <th>Par 4016</th> <th>Source</th> <th>Source min.</th> <th>Source max.</th> </tr> </thead> <tbody> <tr> <td>1</td> <td>Analog input 1</td> <td>1301 MINIMUM AI1</td> <td>1302 MAXIMUM AI1</td> </tr> <tr> <td>2</td> <td>Analog input 2</td> <td>1304 MINIMUM AI2</td> <td>1305 MAXIMUM AI2</td> </tr> <tr> <td>3</td> <td>Current</td> <td>0</td> <td>2 · nominal current</td> </tr> <tr> <td>4</td> <td>Torque</td> <td>-2 · nominal torque</td> <td>2 · nominal torque</td> </tr> <tr> <td>5</td> <td>Power</td> <td>-2 · nominal power</td> <td>2 · nominal power</td> </tr> </tbody> </table> <ul style="list-style-type: none"> • See the figure: A= Normal; B = Inversion (ACT1 MINIMUM > ACT1 MAXIMUM) 	Par 4016	Source	Source min.	Source max.	1	Analog input 1	1301 MINIMUM AI1	1302 MAXIMUM AI1	2	Analog input 2	1304 MINIMUM AI2	1305 MAXIMUM AI2	3	Current	0	2 · nominal current	4	Torque	-2 · nominal torque	2 · nominal torque	5	Power	-2 · nominal power	2 · nominal power
Par 4016	Source	Source min.	Source max.																						
1	Analog input 1	1301 MINIMUM AI1	1302 MAXIMUM AI1																						
2	Analog input 2	1304 MINIMUM AI2	1305 MAXIMUM AI2																						
3	Current	0	2 · nominal current																						
4	Torque	-2 · nominal torque	2 · nominal torque																						
5	Power	-2 · nominal power	2 · nominal power																						
4019	<p>ACT1 MAXIMUM</p> <p>Sets the maximum value for ACT1.</p> <ul style="list-style-type: none"> • See 4018 ACT1 MINIMUM. 																								
4020	<p>ACT2 MINIMUM</p> <p>Sets the minimum value for ACT2.</p> <ul style="list-style-type: none"> • See 4018 ACT1 MINIMUM. 																								
4021	<p>ACT2 MAXIMUM</p> <p>Sets the maximum value for ACT2.</p> <ul style="list-style-type: none"> • See 4018 ACT1 MINIMUM. 																								
4022	<p>SLEEP SELECTION</p> <p>Defines the control for the PID sleep function.</p> <p>0 = NOT SEL– Disables the PID sleep control function.</p> <p>1 = DI1 – Defines digital input DI1 as the control for the PID sleep function.</p> <ul style="list-style-type: none"> • Activating the digital input activates the sleep function. • De-activating the digital input restores PID control. <p>2...6 = DI2...DI6 – Defines digital input DI2...DI6 as the control for the PID sleep function.</p> <ul style="list-style-type: none"> • See DI1 above. <p>7 = INTERNAL – Defines the output rpm/frequency, process reference and process actual value as the control for the PID sleep function. Refer to parameters 4025 WAKE-UP DEV and 4023 PID SLEEP LEVEL.</p> <p>-1 = DI1(INV) – Defines an inverted digital input DI1 as the control for the PID sleep function.</p> <ul style="list-style-type: none"> • De-activating the digital input activates the sleep function. • Activating the digital input restores PID control. <p>-2...-6 = DI2(INV)...DI6(INV) – Defines an inverted digital input DI2...DI6 as the control for the PID sleep function.</p> <ul style="list-style-type: none"> • See DI1(INV) above. 																								

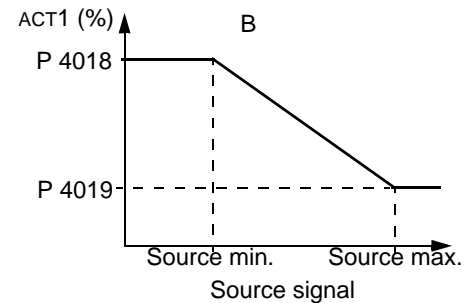
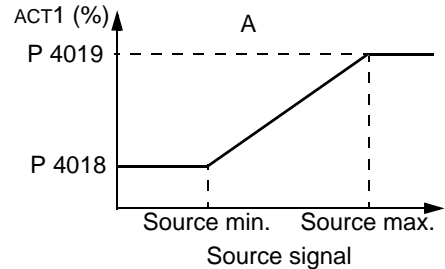

Code	Description	
4023	<p>PID SLEEP LEVEL</p> <p>Sets the motor speed / frequency that enables the PID sleep function – a motor speed / frequency below this level, for at least the time period 4024 PID SLEEP DELAY enables the PID sleep function (stopping the drive).</p> <ul style="list-style-type: none"> • Requires 4022 = 7 (INTERNAL). • See the figure: A = PID output level; B = PID process feedback. 	
4024	<p>PID SLEEP DELAY</p> <p>Sets the time delay for the PID sleep function – a motor speed / frequency below 4023 PID SLEEP LEVEL for at least this time period enables the PID sleep function (stopping the drive).</p> <ul style="list-style-type: none"> • See 4023 PID SLEEP LEVEL above. 	
4025	<p>WAKE-UP DEV</p> <p>Defines the wake-up deviation – a deviation from the setpoint greater than this value, for at least the time period 4026 WAKE-UP DELAY, re-starts the PID controller.</p> <ul style="list-style-type: none"> • Parameters 4006 and 4007 define the units and scale. • Parameter 4005 = 0, Wake-up level = Setpoint - Wake-up deviation. • Parameter 4005 = 1, Wake-up level = Setpoint + Wake-up deviation. • Wake-up level can be above or below setpoint. <p>See the figures:</p> <ul style="list-style-type: none"> • C = Wake-up level when parameter 4005 = 1 • D = Wake-up level when parameter 4005 = 0 • E = Feedback is above wake-up level and lasts longer than 4026 WAKE-UP DELAY – PID function wakes up. • F = Feedback is below wake-up level and lasts longer than 4026 WAKE-UP DELAY – PID function wakes up. 	
4026	<p>WAKE-UP DELAY</p> <p>Defines the wake-up delay – a deviation from the setpoint greater than 4025 WAKE-UP DEV, for at least this time period, re-starts the PID controller.</p>	

Code	Description
4027	<p>PID 1 PARAM SET</p> <p>Process PID (PID1) has two separate sets of parameters, PID set 1 and PID set 2.</p> <ul style="list-style-type: none"> • PID set 1 uses parameters 4001...4026. • PID set 2 uses parameters 4101...4126. <p>PID 1 PARAM SET defines which set is selected.</p> <p>0 = SET 1 – PID Set 1 (parameters 4001...4026) is active.</p> <p>1 = DI1 – Defines digital input DI1 as the control for PID Set selection.</p> <ul style="list-style-type: none"> • Activating the digital input selects PID Set 2. • De-activating the digital input selects PID Set 1. <p>2...6 = DI2...DI6 – Defines digital input DI2...DI6 as the control for PID Set selection.</p> <ul style="list-style-type: none"> • See DI1 above. <p>7 = SET 2 – PID Set 2 (parameters 4101...4126) is active.</p> <p>8...11 = TIMED FUNC 1...4 – Defines the Timed function as the control for the PID Set selection (Timed function de-activated = PID Set 1; Timed function activated = PID Set 2)</p> <ul style="list-style-type: none"> • See Group 36: TIMED FUNCTIONS. <p>12 = 2-ZONE MIN – The drive calculates the difference between setpoint 1 and feedback 1 as well as setpoint 2 and feedback 2. The drive will control the zone (and select the set) that has a larger difference.</p> <ul style="list-style-type: none"> • A positive difference (a setpoint higher than the feedback) is always larger than a negative difference. This keeps feedback values at or above the setpoint. • Controller does not react to the situation of feedback above setpoint if another zone's feedback is closer to its setpoint. <p>13 = 2-ZONE MAX – The drive calculates the difference between setpoint 1 and feedback 1 as well as setpoint 2 and feedback 2. The drive will control the zone (and select the set) that has a smaller difference.</p> <ul style="list-style-type: none"> • A negative difference (a setpoint lower than the feedback) is always smaller than a positive difference. This keeps feedback values at or below the setpoint. • Controller does not react to the situation of feedback below setpoint if another zone's feedback is closer to its setpoint. <p>14 = 2-ZONE AVE – The drive calculates the difference between setpoint 1 and feedback 1 as well as setpoint 2 and feedback 2. In addition, it calculates the average of the deviations and uses it to control zone 1. Therefore one feedback is kept above its setpoint and another is kept as much below its setpoint.</p> <p>-1 = DI1(INV) – Defines an inverted digital input DI1 as the control for PID Set selection.</p> <ul style="list-style-type: none"> • Activating the digital input selects PID Set 1. • De-activating the digital input selects PID Set 2. <p>-2...-6 = DI2(INV)...DI6(INV) – Defines an inverted digital input DI2...DI6 as the control for PID Set selection.</p> <ul style="list-style-type: none"> • See DI1(INV) above.

Group 41: PROCESS PID SET 2

Parameters of this group belong to PID parameter set 2. The operation of parameters 4101...4126 is analogous with set 1 parameters 4001...4026.

PID parameter set 2 can be selected by parameter 4027 PID 1 PARAM SET.

Code	Description
4101 ... 4126	See 4001 ...4026

Group 42: EXT / TRIM PID

This group defines the parameters used for the second PID controller (PID2), which is used for the External / Trimming PID.

The operation of parameters 4201...4221 is analogous with Process PID set 1 (PID1) parameters 4001...4021.

Code	Description
4201 ... 4221	See 4001 ...4021
4228	<p>ACTIVATE</p> <p>Defines the source for enabling the external PID function.</p> <ul style="list-style-type: none"> Requires 4230 TRIM MODE = 0 (NOT SEL). <p>0 = NOT SEL – Disables external PID control.</p> <p>1 = DI1 – Defines digital input DI1 as the control for enabling external PID control.</p> <ul style="list-style-type: none"> Activating the digital input enables external PID control. De-activating the digital input disables external PID control. <p>2...6 = DI2...DI6 – Defines digital input DI2...DI6 as the control for enabling external PID control.</p> <ul style="list-style-type: none"> See DI1 above. <p>7 = DRIVE RUN – Defines the start command as the control for enabling external PID control.</p> <ul style="list-style-type: none"> Activating the start command (drive is running) enables external PID control. <p>8 = ON – Defines the power-on as the control for enabling external PID control.</p> <ul style="list-style-type: none"> Activating power to the drive enables external PID control. <p>9...12 = TIMED FUNC 1...4 – Defines the Timed function as the control for enabling external PID control (Timed function active enables external PID control).</p> <ul style="list-style-type: none"> See Group 36: TIMED FUNCTIONS. <p>-1 = DI1(INV) – Defines an inverted digital input DI1 as the control for enabling external PID control.</p> <ul style="list-style-type: none"> Activating the digital input disables external PID control. De-activating the digital input enables external PID control. <p>-2...-6 = DI2(INV)...DI6(INV) – Defines an inverted digital input DI2...DI6 as the control for enabling external PID control.</p> <ul style="list-style-type: none"> See DI1(INV) above.
4229	<p>OFFSET</p> <p>Defines the offset for the PID output.</p> <ul style="list-style-type: none"> When PID is activated, output starts from this value. When PID is deactivated, output resets to this value. Parameter is active when 4230 TRIM MODE = 0 (trim mode is not active).
4230	<p>TRIM MODE</p> <p>Selects the type of trim, if any. Using the trim it is possible to combine a corrective factor to the drive reference.</p> <p>0 = NOT SEL – Disables the trim function.</p> <p>1 = PROPORTIONAL – Adds a trim factor that is proportional to the rpm/Hz reference.</p> <p>2 = DIRECT – Adds a trim factor based on the control loop's maximum limit.</p>
4231	<p>TRIM SCALE</p> <p>Defines the multiplier (as a percent, plus or minus) used in the trim mode.</p>

Code	Description
4232	<p>CORRECTION SRC</p> <p>Defines the trimming reference for the correction source.</p> <p>1 = PID2REF – Uses appropriate REF MAX (SWITCH A OR B):</p> <ul style="list-style-type: none"> • 1105 REF1 MAX when REF1 is active (A). • 1108 REF2 MAX when REF2 is active (B). <p>2 = PID2OUTPUT – Uses the absolute maximum speed or frequency (Switch C):</p> <ul style="list-style-type: none"> • 2002 MAXIMUM SPEED if 9904 MOTOR CTRL MODE = 1 (VECTOR:SPEED) or 2 (VECTOR:TORQ). • 2008 MAXIMUM FREQ if 9904 MOTOR CTRL MODE = 3 (SCALAR:FREQ).

Group 45: ENERGY SAVING

This group defines the setup of calculation and optimization of energy savings.

Note: The values of saved energy parameters 0174 SAVED KWH, 0175 SAVED MWH, 0176 SAVED AMOUNT 1, 0177 SAVED AMOUNT 2 and 0178 SAVED CO2 are derived from subtracting the drive's energy consumed from the direct-on-line (DOL) consumption calculated on the basis of parameter 4508 PUMP POWER. As such, the accuracy of the values is dependent on the accuracy of the power estimate entered in that parameter.

Code	Description
4502	<p>ENERGY PRICE</p> <p>Price of energy per kWh.</p> <ul style="list-style-type: none"> • Used for reference when energy savings are calculated. • See parameters 0174 SAVED KWH, 0175 SAVED MWH, 0176 SAVED AMOUNT 1, 0177 SAVED AMOUNT 2 and 0178 SAVED CO2 (reduction on carbon dioxide emissions in tn).
4507	<p>CO2 CONV FACTOR</p> <p>Conversion factor for converting energy into CO2 emissions (kg/kWh or tn/MWh). Used for multiplying the saved energy in MWh to calculate the value of parameter 0178 SAVED CO2 (reduction on carbon dioxide emissions in tn).</p>
4508	<p>PUMP POWER</p> <p>Pump power (as a percentage of the nominal motor power) when connected directly to supply (DOL).</p> <ul style="list-style-type: none"> • Used for reference when energy savings are calculated. • See parameters 0174 SAVED KWH, 0175 SAVED MWH, 0176 SAVED AMOUNT 1, 0177 SAVED AMOUNT 2 and 0178 SAVED CO2. • It is possible to use this parameter as the reference power also for other applications than pumps. The reference power can also be some other constant power than a motor connected directly online.
4509	<p>ENERGY RESET</p> <p>Resets energy calculators 0174 SAVED KWH, 0175 SAVED MWH, 0176 SAVED AMOUNT 1, 0177 SAVED AMOUNT 2 and 0178 SAVED CO2.</p>

Group 51: EXT COMM MODULE

This group defines set-up variables for a fieldbus adapter (FBA) communication module. For more information on these parameters, refer to the user's manual supplied with the FBA module.

Code	Description
5101	<p>FBA TYPE</p> <p>Displays the type of the connected fieldbus adapter module.</p> <p>0 = NOT DEFINED – Module not found, or not properly connected, or parameter 9802 is not set to 4 (EXT FBA).</p> <p>1 = PROFIBUS-DP</p> <p>32 = CANopen</p> <p>37 = DEVICENET</p> <p>101 = CONTROLNET</p> <p>128 = ETHERNET</p> <p>132 = PROFINET</p> <p>135 = EtherCAT</p> <p>136 = EPL – Ethernet POWERLINK</p> <p>144 = CC-Link</p>
5102 ... 5126	<p>FB PAR 2...FB PAR 26</p> <p>Refer to communication module documentation for more information on these parameters.</p>
5127	<p>FBA PAR REFRESH</p> <p>Validates any changed fieldbus parameter settings.</p> <p>0 = DONE – Refreshing done.</p> <p>1 = REFRESH – Refreshing.</p> <ul style="list-style-type: none"> • After refreshing, the value reverts automatically to DONE.
5128	<p>FILE CPI FW REV</p> <p>Displays the CPI firmware revision of the drive's fieldbus adapter configuration file. Format is xyz where:</p> <ul style="list-style-type: none"> • x = major revision number • y = minor revision number • z = correction number <p>Example: 107 = revision 1.07</p>
5129	<p>FILE CONFIG ID</p> <p>Displays the revision of the drive's fieldbus adapter module's configuration file identification.</p> <ul style="list-style-type: none"> • File configuration information is drive application program-dependent.
5130	<p>FILE CONFIG REV</p> <p>Contains the revision of the drive's fieldbus adapter module configuration file.</p> <p>Example: 1 = revision 1</p>
5131	<p>FBA STATUS</p> <p>Contains the status of the adapter module.</p> <p>0 = IDLE – Adapter not configured.</p> <p>1 = EXECUT INIT – Adapter is initializing.</p> <p>2 = TIME OUT – A timeout has occurred in the communication between the adapter and the drive.</p> <p>3 = CONFIG ERROR – Adapter configuration error.</p> <ul style="list-style-type: none"> • The revision code of the adapter's CPI firmware revision is older than required CPI firmware version defined in the drive's configuration file (parameter 5132 < 5128). <p>4 = OFF-LINE – Adapter is off-line.</p> <p>5 = ON-LINE – Adapter is on-line.</p> <p>6 = RESET – Adapter is performing a hardware reset.</p>
5132	<p>FBA CPI FW REV</p> <p>Contains the revision of the module's CPI program. Format is xyz where:</p> <ul style="list-style-type: none"> • x = major revision number • y = minor revision number • z = correction number <p>Example: 107 = revision 1.07</p>
5133	<p>FBA APPL FW REV</p> <p>Contains the revision of the module's application program. Format is xyz (see parameter 5132).</p>

Group 52: PANEL COMM

This group defines the communication settings for the control panel port on the drive. Normally, when using the supplied control panel, there is no need to change settings in this group.

In this group, parameter modifications take effect on the next power-up.

Code	Description
5201	STATION ID Defines the address of the drive. <ul style="list-style-type: none"> Two units with the same address are not allowed on-line. Range: 1...247
5202	BAUD RATE Defines the communication speed of the drive in kbits per second (kb/s). 9.6 kb/s 19.2 kb/s 38.4 kb/s 57.6 kb/s 115.2 kb/s
5203	PARITY Sets the character format to be used with the panel communication. 0 = 8 NONE 1 – 8 data bits, no parity, one stop bit. 1 = 8 NONE 2 – 8 data bits, no parity, two stop bits. 2 = 8 EVEN 1 – 8 data bits, even parity, one stop bit. 3 = 8 ODD 1 – 8 data bits, odd parity, one stop bit.
5204	OK MESSAGES Contains a count of valid Modbus messages received by the drive. <ul style="list-style-type: none"> During normal operation, this counter is increasing constantly.
5205	PARITY ERRORS Contains a count of the characters with a parity error that is received from the bus. For high counts, check: <ul style="list-style-type: none"> Parity settings of devices connected on the bus – they must not differ. Ambient electro-magnetic noise levels – high noise levels generate errors.
5206	FRAME ERRORS Contains a count of the characters with a framing error that the bus receives. For high counts, check: <ul style="list-style-type: none"> Communication speed settings of devices connected on the bus – they must not differ. Ambient electro-magnetic noise levels – high noise levels generate errors.
5207	BUFFER OVERRUNS Contains a count of the characters received that cannot be placed in the buffer. <ul style="list-style-type: none"> Longest possible message length for the drive is 128 bytes. Received messages exceeding 128 bytes overflow the buffer. The excess characters are counted.
5208	CRC ERRORS Contains a count of the messages with a CRC error that the drive receives. For high counts, check: <ul style="list-style-type: none"> Ambient electro-magnetic noise levels – high noise levels generate errors. CRC calculations for possible errors.

Group 53: EFB PROTOCOL

This group defines set-up variables used for an embedded fieldbus (EFB) communication protocol. The standard EFB protocol in the ACQ550 is Modbus. See chapter [Embedded fieldbus](#) page 177.

Code	Description
5301	EFB PROTOCOL ID Contains the identification and program revision of the protocol. <ul style="list-style-type: none"> Format: XYYY, where xx = protocol ID, and YY = program revision.
5302	EFB STATION ID Defines the node address of the RS485 link. <ul style="list-style-type: none"> The node address on each unit must be unique.
5303	EFB BAUD RATE Defines the communication speed of the RS485 link in kbits per second (kb/s). 1.2 kb/s 2.4 kb/s 4.8 kb/s 9.6 kb/s 19.2 kb/s 38.4 kb/s 57.6 kb/s 76.8 kb/s
5304	EFB PARITY Defines the data length, parity and stop bits to be used with the RS485 link communication. <ul style="list-style-type: none"> The same settings must be used in all on-line stations. 0 = 8 NONE 1 – 8 data bits, no parity, one stop bit. 1 = 8 NONE 2 – 8 data bits, no parity, two stop bits. 2 = 8 EVEN 1 – 8 data bits, even parity, one stop bit. 3 = 8 ODD 1 – 8 data bits, odd parity, one stop bit.
5305	EFB CTRL PROFILE Selects the communication profile used by the EFB protocol. 0 = ABB DRV LIM – Operation of Control/Status Words conforms to ABB Drives Profile, as used in ACS400. 1 = DCU PROFILE – Operation of Control/Status Words conforms to 32-bit DCU Profile. 2 = ABB DRV FULL – Operation of Control/Status Words conforms to ABB Drives Profile, as used in ACS600/800.
5306	EFB OK MESSAGES Contains a count of valid messages received by the drive. <ul style="list-style-type: none"> During normal operation, this counter is increasing constantly.
5307	EFB CRC ERRORS Contains a count of the messages with a CRC error received by the drive. For high counts, check: <ul style="list-style-type: none"> Ambient electro-magnetic noise levels – high noise levels generate errors. CRC calculations for possible errors.
5308	EFB UART ERRORS Contains a count of the messages with a character error received by the drive.
5309	EFB STATUS Contains the status of the EFB protocol. 0 = IDLE – EFB protocol is configured, but not receiving any messages. 1 = EXECUT INIT – EFB protocol is initializing. 2 = TIME OUT – A timeout has occurred in the communication between the network master and the EFB protocol. 3 = CONFIG ERROR – EFB protocol has a configuration error. 4 = OFF-LINE – EFB protocol is receiving messages that are NOT addressed to this drive. 5 = ON-LINE – EFB protocol is receiving messages that are addressed to this drive. 6 = RESET – EFB protocol is performing a hardware reset. 7 = LISTEN ONLY – EFB protocol is in listen-only mode.
5310	EFB PAR 10 Specifies the parameter mapped to Modbus Register 40005.

Code	Description
5311	EFB PAR 11 Specifies the parameter mapped to Modbus Register 40006.
5312	EFB PAR 12 Specifies the parameter mapped to Modbus Register 40007.
5313	EFB PAR 13 Specifies the parameter mapped to Modbus Register 40008.
5314	EFB PAR 14 Specifies the parameter mapped to Modbus Register 40009.
5315	EFB PAR 15 Specifies the parameter mapped to Modbus Register 40010.
5316	EFB PAR 16 Specifies the parameter mapped to Modbus Register 40011.
5317	EFB PAR 17 Specifies the parameter mapped to Modbus Register 40012.
5318	EFB PAR 18 For Modbus: Sets additional delay in milliseconds before the ACQ550 begins transmitting response to the master request.
5319	EFB PAR 19 ABB Drives profile (ABB DRV LIM or ABB DRV FULL) Control Word. Read only copy of the Fieldbus Control Word.
5320	EFB PAR 20 ABB Drives profile (ABB DRV LIM or ABB DRV FULL) Status Word. Read only copy of the Fieldbus Status Word.

Group 64: LOAD ANALYZER

This group defines the load analyzer, which can be used for analyzing the customer's process and sizing the drive and the motor.

The peak value is logged at 2 ms level, and the distribution loggers are updated on 0.2 s (200 ms) time level. Three different values can be logged.

1. Amplitude logger 1: The measured current is logged continuously. The distribution as a percentage of the nominal current I_{2N} is shown in ten classes.
2. Peak value logger: One signal in group 1 can be logged for the peak (maximum) value. The peak value of the signal, peak time (time when the peak value was detected) as well the frequency, current and DC voltage at the peak time are shown.
3. Amplitude logger 2: One signal in group 1 can be logged for amplitude distribution. The base value (100% value) can be set by the user.

The first logger cannot be reset. The other two loggers can be reset by a user-defined method. They are also reset if either of the signals or the peak value filter time is changed.

Code	Description
6401	PVL SIGNAL Defines (by number) the signal logged for the peak value. <ul style="list-style-type: none"> • Any parameter number in Group 01: OPERATING DATA can be selected. Eg 102 = parameter 0102 SPEED. 100 = NOT SELECTED – No signal (parameter) logged for the peak value. 101...178 – Logs parameter 0101...0178.
6402	PVL FILTER TIME Defines the filter time for peak value logging. <ul style="list-style-type: none"> • 0.0...120.0 – Filter time (seconds).
6403	LOGGERS RESET Defines the source for the reset of peak value logger and amplitude logger 2. <ul style="list-style-type: none"> 0 = NOT SEL – No reset selected. 1 = DI1 – Reset loggers on the rising edge of digital input DI1. 2...6 = DI2...DI6 – Reset loggers on the rising edge of digital input DI2...DI6. 7 = RESET – Reset loggers. Parameter is set to NOT SEL. -1 = DI1(INV) – Reset loggers on the falling edge of digital input DI1. -2...-6 = DI2(INV) ...DI6(INV) – Reset loggers on the falling edge of digital input DI2...DI6.
6404	AL2 SIGNAL Defines the signal logged for amplitude logger 2. <ul style="list-style-type: none"> • Any parameter number in Group 01: OPERATING DATA can be selected. Eg 102 = parameter 0102 SPEED. 100 = NOT SELECTED – No signal (parameter) logged for amplitude distribution (amplitude logger 2). 101...178 – Logs parameter 0101...0178.
6405	AL2 SIGNAL BASE Defines the base value from which the percentage distribution is calculated. <ul style="list-style-type: none"> • Representation and default value depends on the signal selected with parameter 6404 AL2 SIGNAL.
6406	PEAK VALUE Detected peak value of the signal selected with parameter 6401 PVL SIGNAL.
6407	PEAK TIME 1 Date of the peak value detection. <ul style="list-style-type: none"> • Format: Date if the real time clock is operating (dd.mm.yy) / The number of days elapsed after the power-on if the real time clock is not used, or was not set (xx d).
6408	PEAK TIME 2 Time of the peak value detection. <ul style="list-style-type: none"> • Format: hours:minutes:seconds.

Code	Description
6409	CURRENT AT PEAK Current at the moment of the peak value (amperes).
6410	UDC AT PEAK DC voltage at the moment of the peak value (volts).
6411	FREQ AT PEAK Output frequency at the moment of the peak value (herzes).
6412	TIME OF RESET 1 Last reset date of the peak logger and amplitude logger 2. • Format: Date if the real time clock is operating (dd.mm.yy). / The number of days elapsed after the power-on if the real time clock is not used, or was not set (xx d).
6413	TIME OF RESET 2 Last reset time of the peak logger and amplitude logger 2. • Format: hours:minutes:seconds.
6414	AL1RANGE0TO10 Amplitude logger 1 (current in percent of nominal current I_{2N}) 0...10% distribution.
6415	AL1RANGE10TO20 Amplitude logger 1 (current in percent of nominal current I_{2N}) 10...20% distribution.
6416	AL1RANGE20TO30 Amplitude logger 1 (current in percent of nominal current I_{2N}) 20...30% distribution.
6417	AL1RANGE30TO40 Amplitude logger 1 (current in percent of nominal current I_{2N}) 30...40% distribution.
6418	AL1RANGE40TO50 Amplitude logger 1 (current in percent of nominal current I_{2N}) 40...50% distribution.
6419	AL1RANGE50TO60 Amplitude logger 1 (current in percent of nominal current I_{2N}) 50...60% distribution.
6420	AL1RANGE60TO70 Amplitude logger 1 (current in percent of nominal current I_{2N}) 60...70% distribution.
6421	AL1RANGE70TO80 Amplitude logger 1 (current in percent of nominal current I_{2N}) 70...80% distribution.
6422	AL1RANGE80TO90 Amplitude logger 1 (current in percent of nominal current I_{2N}) 80...90% distribution.
6423	AL1RANGE90TO Amplitude logger 1 (current in percent of nominal current I_{2N}) over 90% distribution.
6424	AL2RANGE0TO10 Amplitude logger 2 (signal selection with parameter 6404) 0...10% distribution.
6425	AL2RANGE10TO20 Amplitude logger 2 (signal selection with parameter 6404) 10...20% distribution.
6426	AL2RANGE20TO30 Amplitude logger 2 (signal selection with parameter 6404) 20...30% distribution.
6427	AL2RANGE30TO40 Amplitude logger 2 (signal selection with parameter 6404) 30...40% distribution.
6428	AL2RANGE40TO50 Amplitude logger 2 (signal selection with parameter 6404) 40...50% distribution.
6429	AL2RANGE50TO60 Amplitude logger 2 (signal selection with parameter 6404) 50...60% distribution.
6430	AL2RANGE60TO70 Amplitude logger 2 (signal selection with parameter 6404) 60...70% distribution.
6431	AL2RANGE70TO80 Amplitude logger 2 (signal selection with parameter 6404) 70...80% distribution.

Code	Description
6432	AL2RANGE80TO90 Amplitude logger 2 (signal selection with parameter 6404) 80...90% distribution.
6433	AL2RANGE90TO Amplitude logger 2 (signal selection with parameter 6404) over 90% distribution.

Group 81: PFC CONTROL

This group defines a Pump-Fan Control (PFC) mode of operation. The major features of PFC control are:

- The ACQ550 controls the motor of pump no. 1, varying the motor speed to control the pump capacity. This motor is the speed regulated motor.
- Direct line connections power the motor of pump no. 2 and pump no.3, etc. The ACQ550 switches pump no. 2 (and then pump no. 3, etc.) on and off as needed. These motors are auxiliary motors.
- The ACQ550 PID control uses two signals: a process reference and an actual value feedback. The PID controller adjusts the speed (frequency) of the first pump such that the actual value follows the process reference.
- When demand (defined by the process reference) exceeds the first motor's capacity (user defined as a frequency limit), the PFC control automatically starts an auxiliary pump. The PFC also reduces the speed of the first pump to account for the auxiliary pump's addition to total output. Then, as before, the PID controller adjusts the speed (frequency) of the first pump such that the actual value follows the process reference. If demand continues to increase, PFC adds additional auxiliary pumps, using the same process.
- When demand drops, such that the first pump speed falls below a minimum limit (user defined by a frequency limit), the PFC control automatically stops an auxiliary pump. The PFC also increases the speed of the first pump to account for the auxiliary pump's missing output.
- An Interlock function (when enabled) identifies off-line (out of service) motors, and the PFC control skips to the next available motor in the sequence.
- An Autochange function (when enabled and with the appropriate switchgear) equalizes duty time between the pump motors. Autochange periodically increments the position of each motor in the rotation – the speed regulated motor becomes the last auxiliary motor, the first auxiliary motor becomes the speed regulated motor, etc.

Code	Description
8103	<p>REFERENCE STEP 1</p> <p>Sets a percentage value that is added to the process reference.</p> <ul style="list-style-type: none"> • Applies only when <u>at least one</u> auxiliary (constant speed) motor is running. • Default value is 0%. <p>Example: An ACQ550 operates three parallel pumps that maintain water pressure in a pipe.</p> <ul style="list-style-type: none"> • 4011 INTERNAL SETPNT sets a constant pressure reference that controls the pressure in the pipe. • The speed regulated pump operates alone at low water consumption levels. • As water consumption increases, first one constant speed pump operates, then, the second. • As flow increases, the pressure at the output end of the pipe drops relative to the pressure measured at the input end. As auxiliary motors step in to increase the flow, the adjustments below correct the reference to more closely match the output pressure. • When the first auxiliary pump operates, increase the reference with parameter 8103 REFERENCE STEP 1. • When two auxiliary pumps operate, increase the reference with parameter 8103 REFERENCE STEP 1 + parameter 8104 REFERENCE STEP 2. • When three auxiliary pumps operate, increase the reference with parameter 8103 REFERENCE STEP 1 + parameter 8104 REFERENCE STEP 2 + parameter 8105 REFERENCE STEP 3.

Code	Description
8104	<p>REFERENCE STEP 2</p> <p>Sets a percentage value that is added to the process reference.</p> <ul style="list-style-type: none"> • Applies only when <u>at least two</u> auxiliary (constant speed) motors are running. • See parameter 8103 REFERENCE STEP 1.
8105	<p>REFERENCE STEP 3</p> <p>Sets a percentage value that is added to the process reference.</p> <ul style="list-style-type: none"> • Applies only when <u>at least three</u> auxiliary (constant speed) motors are running. • See parameter 8103 REFERENCE STEP 1.
8109	<p>START FREQ 1</p> <p>Sets the frequency limit used to start the first auxiliary motor. The first auxiliary motor starts if:</p> <ul style="list-style-type: none"> • No auxiliary motors are running. • ACQ550 output frequency exceeds the limit: $8109 + 1$ Hz. • Output frequency stays above a relaxed limit ($8109 - 1$ Hz) for at least the time: 8115 AUX MOT START D. <p>After the first auxiliary motor starts:</p> <ul style="list-style-type: none"> • Output frequency decreases by the value = $(8109 \text{ START FREQ } 1) - (8112 \text{ LOW FREQ } 1)$. • In effect, the output of the speed regulated motor drops to compensate for the input from the auxiliary motor. <p>See the figure, where:</p> <ul style="list-style-type: none"> • A = $(8109 \text{ START FREQ } 1) - (8112 \text{ LOW FREQ } 1)$ • B = Output frequency increase during the start delay. • C = Diagram showing auxiliary motor's run status as frequency increases (1 = On). <p>Note: 8109 START FREQ 1 value must be between:</p> <ul style="list-style-type: none"> • 8112 LOW FREQ 1 • $(2008 \text{ MAXIMUM FREQ}) - 1$.
8110	<p>START FREQ 2</p> <p>Sets the frequency limit used to start the second auxiliary motor.</p> <ul style="list-style-type: none"> • See 8109 START FREQ 1 for a complete description of the operation. <p>The second auxiliary motor starts if:</p> <ul style="list-style-type: none"> • One auxiliary motor is running. • ACQ550 output frequency exceeds the limit: $8110 + 1$. • Output frequency stays above the relaxed limit ($8110 - 1$ Hz) for at least the time: 8115 AUX MOT START D.
8111	<p>START FREQ 3</p> <p>Sets the frequency limit used to start the third auxiliary motor.</p> <ul style="list-style-type: none"> • See 8109 START FREQ 1 for a complete description of the operation. <p>The third auxiliary motor starts if:</p> <ul style="list-style-type: none"> • Two auxiliary motors are running. • ACQ550 output frequency exceeds the limit: $8111 + 1$ Hz. • Output frequency stays above the relaxed limit ($8111 - 1$ Hz) for at least the time: 8115 AUX MOT START D.

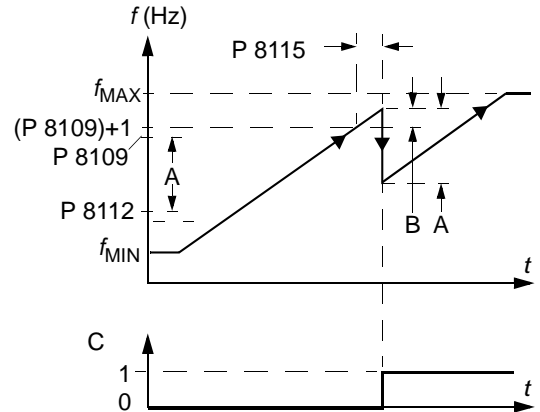

Code	Description
8112	<p>LOW FREQ 1</p> <p>Sets the frequency limit used to stop the first auxiliary motor. The first auxiliary motor stops if:</p> <ul style="list-style-type: none"> • Only one (the first) auxiliary motor is running. • ACQ550 output frequency drops below the limit: 8112 - 1. • Output frequency stays below the relaxed limit (8112 + 1 Hz) for at least the time: 8116 AUX MOT STOP D. <p>After the first auxiliary motor stops:</p> <ul style="list-style-type: none"> • Output frequency increases by the value = (8109 START FREQ 1) - (8112 LOW FREQ 1). • In effect, the output of the speed regulated motor increases to compensate for the loss of the auxiliary motor. <p>See the figure, where:</p> <ul style="list-style-type: none"> • A = (8109 START FREQ 1) - (8112 LOW FREQ 1) • B = Output frequency decrease during the stop delay. • C = Diagram showing auxiliary motor's run status as frequency decreases (1 = On). • Grey path = Shows hysteresis – if time is reversed, the path backwards is not the same. For details on the path for starting, see the diagram at 8109 START FREQ 1. <p>Note: 8112 LOW FREQ 1 value must be between:</p> <ul style="list-style-type: none"> • (2007 MINIMUM FREQ) +1. • 8109 START FREQ 1
8113	<p>LOW FREQ 2</p> <p>Sets the frequency limit used to stop the second auxiliary motor.</p> <ul style="list-style-type: none"> • See 8112 LOW FREQ 1 for a complete description of the operation. <p>The second auxiliary motor stops if:</p> <ul style="list-style-type: none"> • Two auxiliary motors are running. • ACQ550 output frequency drops below the limit: 8113 - 1. • Output frequency stays below the relaxed limit (8113 + 1 Hz) for at least the time: 8116 AUX MOT STOP D.
8114	<p>LOW FREQ 3</p> <p>Sets the frequency limit used to stop the third auxiliary motor.</p> <ul style="list-style-type: none"> • See 8112 LOW FREQ 1 for a complete description of the operation. <p>The third auxiliary motor stops if:</p> <ul style="list-style-type: none"> • Three auxiliary motors are running. • ACQ550 output frequency drops below the limit: 8114 - 1. • Output frequency stays below the relaxed limit (8114 + 1 Hz) for at least the time: 8116 AUX MOT STOP D.
8115	<p>AUX MOT START D</p> <p>Sets the Start Delay for the auxiliary motors.</p> <ul style="list-style-type: none"> • The output frequency must remain above the start frequency limit (parameter 8109, 8110, or 8111) for this time period before the auxiliary motor starts. • See 8109 START FREQ 1 for a complete description of the operation.
8116	<p>AUX MOT STOP D</p> <p>Sets the Stop Delay for the auxiliary motors.</p> <ul style="list-style-type: none"> • The output frequency must remain below the low frequency limit (parameter 8112, 8113, or 8114) for this time period before the auxiliary motor stops. • See 8112 LOW FREQ 1 for a complete description of the operation.

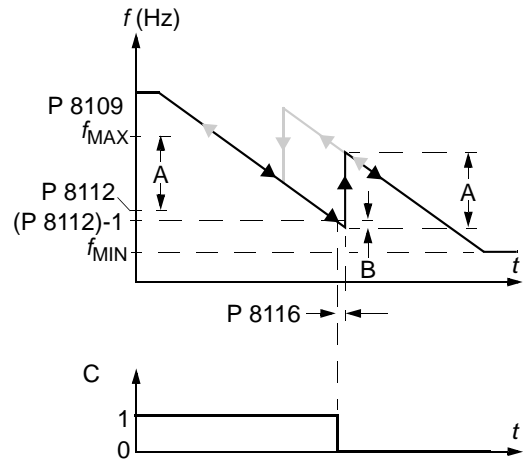

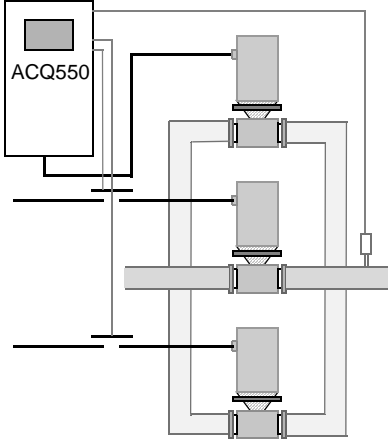
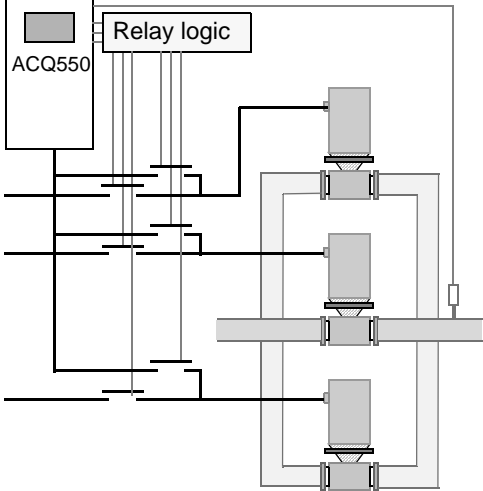
Code	Description
8117	<p>NR OF AUX MOT</p> <p>Sets the number of auxiliary motors.</p> <ul style="list-style-type: none"> • Each auxiliary motor requires a relay output, which the drive uses to send start/stop signals. • The Autochange function, if used, requires an additional relay output for the speed regulated motor. • The following describes the set-up of the required relay outputs. <p>Relay outputs</p> <p>As noted above, each auxiliary motor requires a relay output, which the drive uses to send start/stop signals. The following describes how the drive keeps track of motors and relays.</p> <ul style="list-style-type: none"> • The ACQ550 provides relay outputs RO1...RO3. • An external digital output module (OREL-01) can be added to provide relay outputs RO4...RO6. • Parameters 1401...1403 and 1410...1412 define, respectively, how relays RO1...RO6 are used – the parameter value 31 PFC defines the relay as used for PFC. • The ACQ550 assigns auxiliary motors to relays in ascending order. If the Autochange function is disabled, the first auxiliary motor is the one connected to the first relay with a parameter setting = 31 PFC, and so on. If the Autochange function is used, the assignments rotate. Initially, the speed regulated motor is the one connected to the first relay with a parameter setting = 31 PFC, the first auxiliary motor is the one connected to the second relay with a parameter setting = 31 PFC, and so on. <div style="display: flex; justify-content: space-around; align-items: flex-start;"> <div style="text-align: center;">  <p>Standard PFC mode</p> </div> <div style="text-align: center;">  <p>PFC with Autochange mode</p> </div> </div> <ul style="list-style-type: none"> • The fourth auxiliary motor uses the same reference step, low frequency and start frequency values as the third auxiliary motor.

Code Description

• The table below shows the ACQ550 PFC motor assignments for some typical settings in the Relay Output parameters (1401...1403 and 1410...1412), where the settings are either =31 (PFC), or =X (anything but 31), and where the Autochange function is disabled (8118 AUTOCHNG INTERV = 0.0).

Parameter setting							ACQ550 Relay assignment					
1	4	0	1	1	1	8	Autochange disabled					
4	4	0	0	1	1	1	RO1	RO2	RO3	RO4	RO5	RO6
1	2	3	0	1	2	7						
31	X	X	X	X	X	1	Aux.	X	X	X	X	X
31	31	X	X	X	X	2	Aux.	Aux.	X	X	X	X
31	31	31	X	X	X	3	Aux.	Aux.	Aux.	X	X	X
X	31	31	X	X	X	2	X	Aux.	Aux.	X	X	X
X	X	X	31	X	31	2	X	X	X	Aux.	X	Aux.
31	31	X	X	X	X	1*	Aux.	Aux.	X	X	X	X

* = One additional relay output for the PFC that is in use. One motor is in "sleep" when the other is rotating.

• The table below shows the ACQ550 PFC motor assignments for some typical settings in the Relay Output parameters (1401...1403 and 1410...1412), where the settings are either =31 (PFC), or =X (anything but 31), and where the Autochange function is enabled (8118 AUTOCHNG INTERV = value > 0.0).

Parameter setting							ACQ550 Relay assignment					
1	4	0	1	1	1	8	Autochange enabled					
4	4	0	0	1	1	1	RO1	RO2	RO3	RO4	RO5	RO6
1	2	3	0	1	2	7						
31	31	X	X	X	X	1	PFC	PFC	X	X	X	X
31	31	31	X	X	X	2	PFC	PFC	PFC	X	X	X
X	31	31	X	X	X	1	X	PFC	PFC	X	X	X
X	X	X	31	X	31	1	X	X	X	PFC	X	PFC
31	31	X	X	X	X	0**	PFC	PFC	X	X	X	X

** = No auxiliary motors, but the autochange function is in use. Working as a standard PID-control.

8118 AUTOCHNG INTERV

Controls operation of the Autochange function and sets the interval between changes.

- The Autochange time interval only applies to the time when the speed regulated motor is running.
- See parameter 8119 AUTOCHNG LEVEL for an overview of the Autochange function.
- The drive always coasts to stop when autochange is performed.
- Autochange enabled requires parameter 8120 INTERLOCKS = value > 0.
- 0.1 = TEST MODE – Forces the interval to value 36...48 s.
- 0.0 = NOT SEL – Disables the Autochange function.
- 0.1...336 – The operating time interval (the time when the start signal is on) between automatic motor changes.

⚠ WARNING! When enabled, the Autochange function requires the interlocks (8120 INTERLOCKS = value > 0) enabled. During autochange the power output is interrupted and the drive coasts to stop, preventing damage to the contacts.

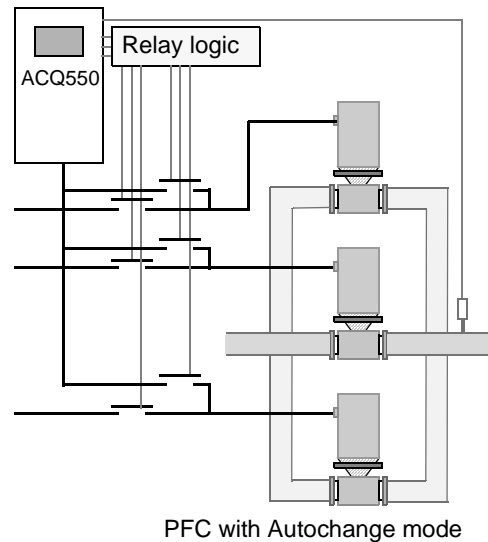

Code	Description
8119	<p>AUTOCHNG LEVEL</p> <p>Sets an upper limit, as a percent of output capacity, for the autochange logic. When the output from the PID/PFC control block exceeds this limit, autochange is prevented. For example, use this parameter to deny autochange when the Pump-Fan system is operating near maximum capacity.</p> <p>Autochange overview</p> <p>The purpose of the autochange operation is to equalize duty time between multiple motors used in a system. At each autochange operation:</p> <ul style="list-style-type: none"> • A different motor takes a turn connected to the ACQ550 output – the speed regulated motor. • The starting order of the other motors rotates. <p>The Autochange function requires:</p> <ul style="list-style-type: none"> • External switchgear for changing the drive's output power connections. • Parameter 8120 INTERLOCKS = value > 0. <p>Autochange is performed when:</p> <ul style="list-style-type: none"> • The running time since the previous autochange reaches the time set by 8118 AUTOCHNG INTERV. • The PFC input is below the level set by this parameter, 8119 AUTOCHNG LEVEL. <p>Note: The ACQ550 always coasts to stop when autochange is performed.</p> <p>In an autochange, the Autochange function does all of the following (see the figure):</p> <ul style="list-style-type: none"> • Initiates a change when the running time, since the last autochange, reaches 8118 AUTOCHNG INTERV, and PFC input is below limit 8119 AUTOCHNG LEVEL. • Stops the speed regulated motor. • Switches off the contactor of the speed regulated motor. • Increments the starting order counter, to change the starting order for the motors. • Identifies the next motor in line to be the speed regulated motor. • Switches off the above motor's contactor, if the motor was running. Any other running motors are not interrupted. • Switches on the contactor of the new speed regulated motor. The autochange switchgear connects this motor to the ACQ550 power output. • Delays motor start for the time 8122 PFC START DELAY. • Starts the speed regulated motor. • Identifies the next constant speed motor in the rotation. • Switches the above motor on, but only if the new speed regulated motor had been running (as a constant speed motor) – This step keeps an equal number of motors running before and after autochange. • Continues with normal PFC operation. <p>Starting order counter</p> <p>The operation of the starting-order counter:</p> <ul style="list-style-type: none"> • The relay output parameter definitions (1401...1403 and 1410...1412) establish the initial motor sequence. (The lowest parameter number with a value 31 (PFC) identifies the relay connected to 1PFC, the first motor, and so on.) • Initially, 1PFC = speed regulated motor, 2PFC = 1st auxiliary motor, etc. • The first autochange shifts the sequence to: 2PFC = speed regulated motor, 3PFC = 1st auxiliary motor, ..., 1PFC = last auxiliary motor. • The next autochange shifts the sequence again, and so on. • If the autochange cannot start a needed motor because all inactive motors are interlocked, the drive displays an alarm (2015, PFC I LOCK). • When ACQ550 power supply is switched off, the counter preserves the current Autochange rotation positions in permanent memory. When power is restored, the Autochange rotation starts at the position stored in memory. • If the PFC relay configuration is changed (or if the PFC enable value is changed), the rotation is reset. (See the first bullet above.)

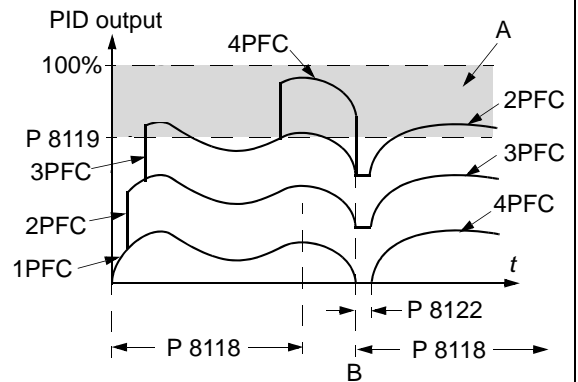

A = Area above 8119 AUTOCHNG LEVEL – autochange not allowed.
 B = Autochange occurs.
 1PFC, etc. = PID output associated with each motor.

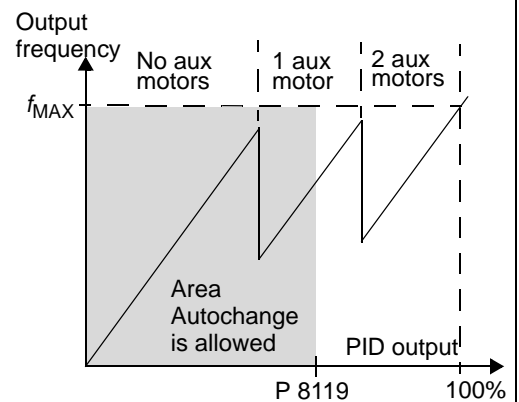

Code	Description																								
8120	<p>INTERLOCKS</p> <p>Defines operation of the Interlock function. When the Interlock function is enabled:</p> <ul style="list-style-type: none"> • An interlock is active when its command signal is absent. • An interlock is inactive when its command signal is present. • The ACQ550 will not start if a start command occurs when the speed regulated motor's interlock is active – the control panel displays an alarm (2015, PFC I LOCK). <p>Wire each Interlock circuit as follows:</p> <ul style="list-style-type: none"> • Wire a contact of the motor's On/Off switch to the Interlock circuit – the drive's PFC logic can then recognize that the motor is switched off and start the next available motor. • Wire a contact of the motor thermal relay (or other protective device in the motor circuit) to the Interlock input – the drive's PFC logic can then recognize that a motor fault is activated and stop the motor. <p>0 = NOT SEL – Disables the Interlock function. All digital inputs are available for other purposes.</p> <ul style="list-style-type: none"> • Requires 8118 AUTOCHNG INTERV = 0.0 (The Autochange function must be disabled if Interlock function is disabled.) <p>1 = DI1 – Enables the Interlock function and assigns a digital input (starting with DI1) to the interlock signal for each PFC relay. These assignments are defined in the following table and depend on:</p> <ul style="list-style-type: none"> • the number of PFC relays [number of parameters 1401...1403 and 1410...1412 with value = 31 (PFC)] • the Autochange function status (disabled if 8118 AUTOCHNG INTERV = 0.0, and otherwise enabled). <table border="1" style="width: 100%; border-collapse: collapse;"> <thead> <tr> <th style="background-color: #d3d3d3;">No. PFC relays</th> <th style="background-color: #d3d3d3;">Autochange disabled (P 8118)</th> <th style="background-color: #d3d3d3;">Autochange enabled (P 8118)</th> </tr> </thead> <tbody> <tr> <td style="text-align: center;">0</td> <td>DI1: Speed Reg Motor DI2...DI6: Free</td> <td>Not allowed</td> </tr> <tr> <td style="text-align: center;">1</td> <td>DI1: Speed Reg Motor DI2: First PFC Relay DI3...DI6: Free</td> <td>DI1: First PFC Relay DI2...DI6: Free</td> </tr> <tr> <td style="text-align: center;">2</td> <td>DI1: Speed Reg Motor DI2: First PFC Relay DI3: Second PFC Relay DI4...DI6: Free</td> <td>DI1: First PFC Relay DI2: Second PFC Relay DI3...DI6: Free</td> </tr> <tr> <td style="text-align: center;">3</td> <td>DI1: Speed Reg Motor DI2: First PFC Relay DI3: Second PFC Relay DI4: Third PFC Relay DI5...DI6: Free</td> <td>DI1: First PFC Relay DI2: Second PFC Relay DI3: Third PFC Relay DI4...DI6: Free</td> </tr> <tr> <td style="text-align: center;">4</td> <td>DI1: Speed Reg Motor DI2: First PFC Relay DI3: Second PFC Relay DI4: Third PFC Relay DI5: Fourth PFC Relay DI6: Free</td> <td>DI1: First PFC Relay DI2: Second PFC Relay DI3: Third PFC Relay DI4: Fourth PFC Relay DI5...DI6: Free</td> </tr> <tr> <td style="text-align: center;">5</td> <td>DI1: Speed Reg Motor DI2: First PFC Relay DI3: Second PFC Relay DI4: Third PFC Relay DI5: Fourth PFC Relay DI6: Fifth PFC Relay</td> <td>DI1: First PFC Relay DI2: Second PFC Relay DI3: Third PFC Relay DI4: Fourth PFC Relay DI5: Fifth PFC Relay DI6: Free</td> </tr> <tr> <td style="text-align: center;">6</td> <td>Not allowed</td> <td>DI1: First PFC Relay DI2: Second PFC Relay DI3: Third PFC Relay DI4: Fourth PFC Relay DI5: Fifth PFC Relay DI6: Sixth PFC Relay</td> </tr> </tbody> </table>	No. PFC relays	Autochange disabled (P 8118)	Autochange enabled (P 8118)	0	DI1: Speed Reg Motor DI2...DI6: Free	Not allowed	1	DI1: Speed Reg Motor DI2: First PFC Relay DI3...DI6: Free	DI1: First PFC Relay DI2...DI6: Free	2	DI1: Speed Reg Motor DI2: First PFC Relay DI3: Second PFC Relay DI4...DI6: Free	DI1: First PFC Relay DI2: Second PFC Relay DI3...DI6: Free	3	DI1: Speed Reg Motor DI2: First PFC Relay DI3: Second PFC Relay DI4: Third PFC Relay DI5...DI6: Free	DI1: First PFC Relay DI2: Second PFC Relay DI3: Third PFC Relay DI4...DI6: Free	4	DI1: Speed Reg Motor DI2: First PFC Relay DI3: Second PFC Relay DI4: Third PFC Relay DI5: Fourth PFC Relay DI6: Free	DI1: First PFC Relay DI2: Second PFC Relay DI3: Third PFC Relay DI4: Fourth PFC Relay DI5...DI6: Free	5	DI1: Speed Reg Motor DI2: First PFC Relay DI3: Second PFC Relay DI4: Third PFC Relay DI5: Fourth PFC Relay DI6: Fifth PFC Relay	DI1: First PFC Relay DI2: Second PFC Relay DI3: Third PFC Relay DI4: Fourth PFC Relay DI5: Fifth PFC Relay DI6: Free	6	Not allowed	DI1: First PFC Relay DI2: Second PFC Relay DI3: Third PFC Relay DI4: Fourth PFC Relay DI5: Fifth PFC Relay DI6: Sixth PFC Relay
No. PFC relays	Autochange disabled (P 8118)	Autochange enabled (P 8118)																							
0	DI1: Speed Reg Motor DI2...DI6: Free	Not allowed																							
1	DI1: Speed Reg Motor DI2: First PFC Relay DI3...DI6: Free	DI1: First PFC Relay DI2...DI6: Free																							
2	DI1: Speed Reg Motor DI2: First PFC Relay DI3: Second PFC Relay DI4...DI6: Free	DI1: First PFC Relay DI2: Second PFC Relay DI3...DI6: Free																							
3	DI1: Speed Reg Motor DI2: First PFC Relay DI3: Second PFC Relay DI4: Third PFC Relay DI5...DI6: Free	DI1: First PFC Relay DI2: Second PFC Relay DI3: Third PFC Relay DI4...DI6: Free																							
4	DI1: Speed Reg Motor DI2: First PFC Relay DI3: Second PFC Relay DI4: Third PFC Relay DI5: Fourth PFC Relay DI6: Free	DI1: First PFC Relay DI2: Second PFC Relay DI3: Third PFC Relay DI4: Fourth PFC Relay DI5...DI6: Free																							
5	DI1: Speed Reg Motor DI2: First PFC Relay DI3: Second PFC Relay DI4: Third PFC Relay DI5: Fourth PFC Relay DI6: Fifth PFC Relay	DI1: First PFC Relay DI2: Second PFC Relay DI3: Third PFC Relay DI4: Fourth PFC Relay DI5: Fifth PFC Relay DI6: Free																							
6	Not allowed	DI1: First PFC Relay DI2: Second PFC Relay DI3: Third PFC Relay DI4: Fourth PFC Relay DI5: Fifth PFC Relay DI6: Sixth PFC Relay																							

Code	Description																								
	<p>2 = DI2 – Enables the Interlock function and assigns a digital input (starting with DI2) to the interlock signal for each PFC relay. These assignments are defined in the following table and depend on:</p> <ul style="list-style-type: none"> • the number of PFC relays [number of parameters 1401...1403 and 1410...1412 with value = 31 (PFC)] • the Autochange function status (disabled if 8118 AUTOCHNG INTERV = 0.0, and otherwise enabled). <table border="1"> <thead> <tr> <th>No. PFC relays</th> <th>Autochange disabled (P 8118)</th> <th>Autochange enabled (P 8118)</th> </tr> </thead> <tbody> <tr> <td>0</td> <td>DI1: Free DI2: Speed Reg Motor DI3...DI6: Free</td> <td>Not allowed</td> </tr> <tr> <td>1</td> <td>DI1: Free DI2: Speed Reg Motor DI3: First PFC Relay DI4...DI6: Free</td> <td>DI1: Free DI2: First PFC Relay DI3...DI6: Free</td> </tr> <tr> <td>2</td> <td>DI1: Free DI2: Speed Reg Motor DI3: First PFC Relay DI4: Second PFC Relay DI5...DI6: Free</td> <td>DI1: Free DI2: First PFC Relay DI3: Second PFC Relay DI4...DI6: Free</td> </tr> <tr> <td>3</td> <td>DI1: Free DI2: Speed Reg Motor DI3: First PFC Relay DI4: Second PFC Relay DI5: Third PFC Relay DI6: Free</td> <td>DI1: Free DI2: First PFC Relay DI3: Second PFC Relay DI4: Third PFC Relay DI5...DI6: Free</td> </tr> <tr> <td>4</td> <td>DI1: Free DI2: Speed Reg Motor DI3: First PFC Relay DI4: Second PFC Relay DI5: Third PFC Relay DI6: Fourth PFC Relay</td> <td>DI1: Free DI2: First PFC Relay DI3: Second PFC Relay DI4: Third PFC Relay DI5: Fourth PFC Relay DI6: Free</td> </tr> <tr> <td>5</td> <td>Not allowed</td> <td>DI1: Free DI2: First PFC Relay DI3: Second PFC Relay DI4: Third PFC Relay DI5: Fourth PFC Relay DI6: Fifth PFC Relay</td> </tr> <tr> <td>6</td> <td>Not allowed</td> <td>Not allowed</td> </tr> </tbody> </table>	No. PFC relays	Autochange disabled (P 8118)	Autochange enabled (P 8118)	0	DI1: Free DI2: Speed Reg Motor DI3...DI6: Free	Not allowed	1	DI1: Free DI2: Speed Reg Motor DI3: First PFC Relay DI4...DI6: Free	DI1: Free DI2: First PFC Relay DI3...DI6: Free	2	DI1: Free DI2: Speed Reg Motor DI3: First PFC Relay DI4: Second PFC Relay DI5...DI6: Free	DI1: Free DI2: First PFC Relay DI3: Second PFC Relay DI4...DI6: Free	3	DI1: Free DI2: Speed Reg Motor DI3: First PFC Relay DI4: Second PFC Relay DI5: Third PFC Relay DI6: Free	DI1: Free DI2: First PFC Relay DI3: Second PFC Relay DI4: Third PFC Relay DI5...DI6: Free	4	DI1: Free DI2: Speed Reg Motor DI3: First PFC Relay DI4: Second PFC Relay DI5: Third PFC Relay DI6: Fourth PFC Relay	DI1: Free DI2: First PFC Relay DI3: Second PFC Relay DI4: Third PFC Relay DI5: Fourth PFC Relay DI6: Free	5	Not allowed	DI1: Free DI2: First PFC Relay DI3: Second PFC Relay DI4: Third PFC Relay DI5: Fourth PFC Relay DI6: Fifth PFC Relay	6	Not allowed	Not allowed
No. PFC relays	Autochange disabled (P 8118)	Autochange enabled (P 8118)																							
0	DI1: Free DI2: Speed Reg Motor DI3...DI6: Free	Not allowed																							
1	DI1: Free DI2: Speed Reg Motor DI3: First PFC Relay DI4...DI6: Free	DI1: Free DI2: First PFC Relay DI3...DI6: Free																							
2	DI1: Free DI2: Speed Reg Motor DI3: First PFC Relay DI4: Second PFC Relay DI5...DI6: Free	DI1: Free DI2: First PFC Relay DI3: Second PFC Relay DI4...DI6: Free																							
3	DI1: Free DI2: Speed Reg Motor DI3: First PFC Relay DI4: Second PFC Relay DI5: Third PFC Relay DI6: Free	DI1: Free DI2: First PFC Relay DI3: Second PFC Relay DI4: Third PFC Relay DI5...DI6: Free																							
4	DI1: Free DI2: Speed Reg Motor DI3: First PFC Relay DI4: Second PFC Relay DI5: Third PFC Relay DI6: Fourth PFC Relay	DI1: Free DI2: First PFC Relay DI3: Second PFC Relay DI4: Third PFC Relay DI5: Fourth PFC Relay DI6: Free																							
5	Not allowed	DI1: Free DI2: First PFC Relay DI3: Second PFC Relay DI4: Third PFC Relay DI5: Fourth PFC Relay DI6: Fifth PFC Relay																							
6	Not allowed	Not allowed																							

Code	Description																																							
	<p>3 = DI3 – Enables the Interlocks function and assigns a digital input (starting with DI3) to the interlock signal for each PFC relay. These assignments are defined in the following table and depend on:</p> <ul style="list-style-type: none"> • the number of PFC relays [number of parameters 1401...1403 and 1410...1412 with value = 31 (PFC)] • the Autochange function status (disabled if 8118 AUTOCHNG INTERV = 0.0, and otherwise enabled). <table border="1"> <thead> <tr> <th>No. PFC relays</th> <th>Autochange disabled (P 8118)</th> <th>Autochange enabled (P 8118)</th> </tr> </thead> <tbody> <tr> <td>0</td> <td>DI1...DI2: Free DI3: Speed Reg Motor DI4...DI6: Free</td> <td>Not allowed</td> </tr> <tr> <td>1</td> <td>DI1...DI2: Free DI3: Speed Reg Motor DI4: First PFC Relay DI5...DI6: Free</td> <td>DI1...DI2: Free DI3: First PFC Relay DI4...DI6: Free</td> </tr> <tr> <td>2</td> <td>DI1...DI2: Free DI3: Speed Reg Motor DI4: First PFC Relay DI5: Second PFC Relay DI6: Free</td> <td>DI1...DI2: Free DI3: First PFC Relay DI4: Second PFC Relay DI5...DI6: Free</td> </tr> <tr> <td>3</td> <td>DI1...DI2: Free DI3: Speed Reg Motor DI4: First PFC Relay DI5: Second PFC Relay DI6: Third PFC Relay</td> <td>DI1...DI2: Free DI3: First PFC Relay DI4: Second PFC Relay DI5: Third PFC Relay DI6: Free</td> </tr> <tr> <td>4</td> <td>Not allowed</td> <td>DI1...DI2: Free DI3: First PFC Relay DI4: Second PFC Relay DI5: Third PFC Relay DI6: Fourth PFC Relay</td> </tr> <tr> <td>5...6</td> <td>Not allowed</td> <td>Not allowed</td> </tr> </tbody> </table> <p>4 = DI4 – Enables the Interlock function and assigns a digital input (starting with DI4) to the interlock signal for each PFC relay. These assignments are defined in the following table and depend on:</p> <ul style="list-style-type: none"> • the number of PFC relays [number of parameters 1401...1403 and 1410...1412 with value = 31 (PFC)] • the Autochange function status (disabled if 8118 AUTOCHNG INTERV = 0.0, and otherwise enabled). <table border="1"> <thead> <tr> <th>No. PFC relays</th> <th>Autochange disabled (P 8118)</th> <th>Autochange enabled (P 8118)</th> </tr> </thead> <tbody> <tr> <td>0</td> <td>DI1...DI3: Free DI4: Speed Reg Motor DI5...DI6: Free</td> <td>Not allowed</td> </tr> <tr> <td>1</td> <td>DI1...DI3: Free DI4: Speed Reg Motor DI5: First PFC Relay DI6: Free</td> <td>DI1...DI3: Free DI4: First PFC Relay DI5...DI6: Free</td> </tr> <tr> <td>2</td> <td>DI1...DI3: Free DI4: Speed Reg Motor DI5: First PFC Relay DI6: Second PFC Relay</td> <td>DI1...DI3: Free DI4: First PFC Relay DI5: Second PFC Relay DI6: Free</td> </tr> <tr> <td>3</td> <td>Not allowed</td> <td>DI1...DI3: Free DI4: First PFC Relay DI5: Second PFC Relay DI6: Third PFC Relay</td> </tr> <tr> <td>4...6</td> <td>Not allowed</td> <td>Not allowed</td> </tr> </tbody> </table>	No. PFC relays	Autochange disabled (P 8118)	Autochange enabled (P 8118)	0	DI1...DI2: Free DI3: Speed Reg Motor DI4...DI6: Free	Not allowed	1	DI1...DI2: Free DI3: Speed Reg Motor DI4: First PFC Relay DI5...DI6: Free	DI1...DI2: Free DI3: First PFC Relay DI4...DI6: Free	2	DI1...DI2: Free DI3: Speed Reg Motor DI4: First PFC Relay DI5: Second PFC Relay DI6: Free	DI1...DI2: Free DI3: First PFC Relay DI4: Second PFC Relay DI5...DI6: Free	3	DI1...DI2: Free DI3: Speed Reg Motor DI4: First PFC Relay DI5: Second PFC Relay DI6: Third PFC Relay	DI1...DI2: Free DI3: First PFC Relay DI4: Second PFC Relay DI5: Third PFC Relay DI6: Free	4	Not allowed	DI1...DI2: Free DI3: First PFC Relay DI4: Second PFC Relay DI5: Third PFC Relay DI6: Fourth PFC Relay	5...6	Not allowed	Not allowed	No. PFC relays	Autochange disabled (P 8118)	Autochange enabled (P 8118)	0	DI1...DI3: Free DI4: Speed Reg Motor DI5...DI6: Free	Not allowed	1	DI1...DI3: Free DI4: Speed Reg Motor DI5: First PFC Relay DI6: Free	DI1...DI3: Free DI4: First PFC Relay DI5...DI6: Free	2	DI1...DI3: Free DI4: Speed Reg Motor DI5: First PFC Relay DI6: Second PFC Relay	DI1...DI3: Free DI4: First PFC Relay DI5: Second PFC Relay DI6: Free	3	Not allowed	DI1...DI3: Free DI4: First PFC Relay DI5: Second PFC Relay DI6: Third PFC Relay	4...6	Not allowed	Not allowed
No. PFC relays	Autochange disabled (P 8118)	Autochange enabled (P 8118)																																						
0	DI1...DI2: Free DI3: Speed Reg Motor DI4...DI6: Free	Not allowed																																						
1	DI1...DI2: Free DI3: Speed Reg Motor DI4: First PFC Relay DI5...DI6: Free	DI1...DI2: Free DI3: First PFC Relay DI4...DI6: Free																																						
2	DI1...DI2: Free DI3: Speed Reg Motor DI4: First PFC Relay DI5: Second PFC Relay DI6: Free	DI1...DI2: Free DI3: First PFC Relay DI4: Second PFC Relay DI5...DI6: Free																																						
3	DI1...DI2: Free DI3: Speed Reg Motor DI4: First PFC Relay DI5: Second PFC Relay DI6: Third PFC Relay	DI1...DI2: Free DI3: First PFC Relay DI4: Second PFC Relay DI5: Third PFC Relay DI6: Free																																						
4	Not allowed	DI1...DI2: Free DI3: First PFC Relay DI4: Second PFC Relay DI5: Third PFC Relay DI6: Fourth PFC Relay																																						
5...6	Not allowed	Not allowed																																						
No. PFC relays	Autochange disabled (P 8118)	Autochange enabled (P 8118)																																						
0	DI1...DI3: Free DI4: Speed Reg Motor DI5...DI6: Free	Not allowed																																						
1	DI1...DI3: Free DI4: Speed Reg Motor DI5: First PFC Relay DI6: Free	DI1...DI3: Free DI4: First PFC Relay DI5...DI6: Free																																						
2	DI1...DI3: Free DI4: Speed Reg Motor DI5: First PFC Relay DI6: Second PFC Relay	DI1...DI3: Free DI4: First PFC Relay DI5: Second PFC Relay DI6: Free																																						
3	Not allowed	DI1...DI3: Free DI4: First PFC Relay DI5: Second PFC Relay DI6: Third PFC Relay																																						
4...6	Not allowed	Not allowed																																						

Code	Description																											
	<p>5 = DI5 – Enables the Interlock function and assigns a digital input (starting with DI5) to the interlock signal for each PFC relay. These assignments are defined in the following table and depend on:</p> <ul style="list-style-type: none"> • the number of PFC relays [number of parameters 1401...1403 and 1410...1412 with value = 31 (PFC)] • the Autochange function status (disabled if 8118 AUTOCHNG INTERV = 0.0, and otherwise enabled). <table border="1"> <thead> <tr> <th>No. PFC relays</th> <th>Autochange disabled (P 8118)</th> <th>Autochange enabled (P 8118)</th> </tr> </thead> <tbody> <tr> <td>0</td> <td>DI1...DI4: Free DI5: Speed Reg Motor DI6: Free</td> <td>Not allowed</td> </tr> <tr> <td>1</td> <td>DI1...DI4: Free DI5: Speed Reg Motor DI6: First PFC Relay</td> <td>DI1...DI4: Free DI5: First PFC Relay DI6: Free</td> </tr> <tr> <td>2</td> <td>Not allowed</td> <td>DI1...DI4: Free DI5: First PFC Relay DI6: Second PFC Relay</td> </tr> <tr> <td>3...6</td> <td>Not allowed</td> <td>Not allowed</td> </tr> </tbody> </table> <p>6 = DI6 – Enables the Interlock function and assigns digital input DI6 to the interlock signal for the speed regulated motor.</p> <ul style="list-style-type: none"> • Requires 8118 AUTOCHNG INTERV = 0.0. <table border="1"> <thead> <tr> <th>No. PFC relays</th> <th>Autochange disabled</th> <th>Autochange enabled</th> </tr> </thead> <tbody> <tr> <td>0</td> <td>DI1...DI5: Free DI6: Speed Reg Motor</td> <td>Not allowed</td> </tr> <tr> <td>1</td> <td>Not allowed</td> <td>DI1...DI5: Free DI6: First PFC Relay</td> </tr> <tr> <td>2...6</td> <td>Not allowed</td> <td>Not allowed</td> </tr> </tbody> </table>	No. PFC relays	Autochange disabled (P 8118)	Autochange enabled (P 8118)	0	DI1...DI4: Free DI5: Speed Reg Motor DI6: Free	Not allowed	1	DI1...DI4: Free DI5: Speed Reg Motor DI6: First PFC Relay	DI1...DI4: Free DI5: First PFC Relay DI6: Free	2	Not allowed	DI1...DI4: Free DI5: First PFC Relay DI6: Second PFC Relay	3...6	Not allowed	Not allowed	No. PFC relays	Autochange disabled	Autochange enabled	0	DI1...DI5: Free DI6: Speed Reg Motor	Not allowed	1	Not allowed	DI1...DI5: Free DI6: First PFC Relay	2...6	Not allowed	Not allowed
No. PFC relays	Autochange disabled (P 8118)	Autochange enabled (P 8118)																										
0	DI1...DI4: Free DI5: Speed Reg Motor DI6: Free	Not allowed																										
1	DI1...DI4: Free DI5: Speed Reg Motor DI6: First PFC Relay	DI1...DI4: Free DI5: First PFC Relay DI6: Free																										
2	Not allowed	DI1...DI4: Free DI5: First PFC Relay DI6: Second PFC Relay																										
3...6	Not allowed	Not allowed																										
No. PFC relays	Autochange disabled	Autochange enabled																										
0	DI1...DI5: Free DI6: Speed Reg Motor	Not allowed																										
1	Not allowed	DI1...DI5: Free DI6: First PFC Relay																										
2...6	Not allowed	Not allowed																										

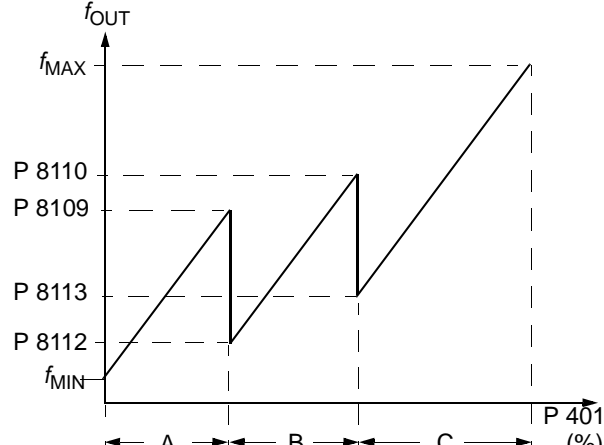
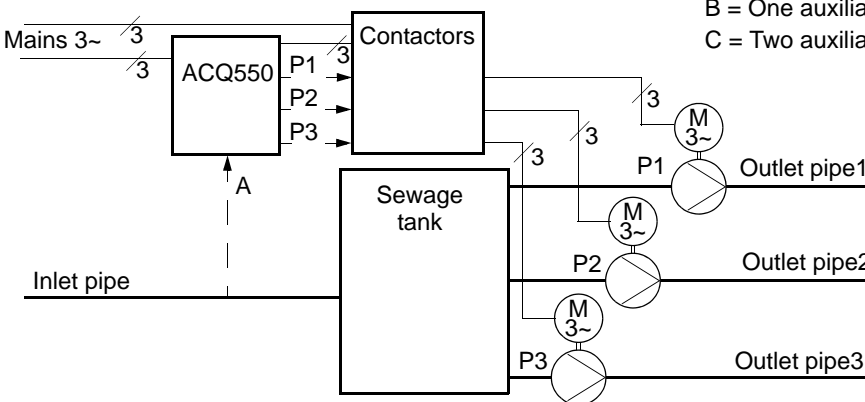
Code	Description
8121	<p>REG BYPASS CTRL</p> <p>Selects Regulator by-pass control. When enabled, Regulator by-pass control provides a simple control mechanism without a PID regulator.</p> <ul style="list-style-type: none"> Use Regulator by-pass control only in special applications. <p>0 = NO – Disables Regulator by-pass control. The drive uses the normal PFC reference: 1106 REF2 SELECT.</p> <p>1 = YES – Enables Regulator by-pass control.</p> <ul style="list-style-type: none"> The process PID regulator is bypassed. Actual value of PID is used as the PFC reference (input). Normally EXT REF2 is used as the PFC reference. The drive uses the feedback signal defined by 4014 FBK SEL (or 4114) for the PFC frequency reference. The figure shows the relation between the control signal 4014 FBK SEL (OR 4114) and the speed regulated motor's frequency in a three-motor system. <p>Example: In the diagram below, the pumping station's outlet flow is controlled by the measured inlet flow (A).</p>  <p>A = No auxiliary motors running B = One auxiliary motor running C = Two auxiliary motors running</p> 
8122	<p>PFC START DELAY</p> <p>Sets the start delay for speed regulated motors in the system. Using the delay, the drive works as follows:</p> <ul style="list-style-type: none"> Switches on the contactor of the speed regulated motor – connecting the motor to the ACQ550 power output. Delays motor start for the time 8122 PFC START DELAY. Starts the speed regulated motor. Starts auxiliary motors. See parameter 8115 for delay. <p>⚠ WARNING! Motors equipped with star-delta starters require a PFC Start Delay.</p> <ul style="list-style-type: none"> After the ACQ550 relay output switches a motor on, the star-delta starter must switch to the star-connection and then back to the delta-connection before the drive applies power. So, the PFC Start Delay must be longer than the time setting of the star-delta starter.
8123	<p>PFC ENABLE</p> <p>Selects PFC control. When enabled, PFC control:</p> <ul style="list-style-type: none"> Switches in, or out, auxiliary constant speed motors as output demand increases or decreases. Parameters 8109 START FREQ 1 to 8114 LOW FREQ 3 define the switch points in terms of the drive output frequency. Adjusts the speed regulated motor output down, as auxiliary motors are added, and adjusts the speed regulated motor output up, as auxiliary motors are taken off line. Provides Interlock functions, if enabled. Requires 9904 MOTOR CTRL MODE = 3 (SCALAR:FREQ). <p>0 = NOT SEL – Disables PFC control.</p> <p>1 = ACTIVE – Enables PFC control.</p>

Code	Description
8124	<p>ACC IN AUX STOP</p> <p>Sets the PFC acceleration time for a zero-to-maximum frequency ramp. This PFC acceleration ramp:</p> <ul style="list-style-type: none"> • Applies to the speed regulated motor, when an auxiliary motor is switched off. • Replaces the acceleration ramp defined in Group 22: ACCEL/DECEL. • Applies only until the output of the regulated motor increases by an amount equal to the output of the switched off auxiliary motor. Then the acceleration ramp defined in Group 22: ACCEL/DECEL applies. <p>0 = NOT SEL. 0.1...1800 – Activates this function using the value entered as the acceleration time.</p>
8125	<p>DEC IN AUX START</p> <p>Sets the PFC deceleration time for a maximum-to-zero frequency ramp. This PFC deceleration ramp:</p> <ul style="list-style-type: none"> • Applies to the speed regulated motor, when an auxiliary motor is switched on. • Replaces the deceleration ramp defined in Group 22: ACCEL/DECEL. • Applies only until the output of the regulated motor decreases by an amount equal to the output of the auxiliary motor. Then the deceleration ramp defined in Group 22: ACCEL/DECEL applies. <p>0 = NOT SEL. 0.1...1800 – Activates this function using the value entered as the deceleration time.</p>
8126	<p>TIMED AUTOCHNG</p> <p>Sets the autochange using a Timed function. See parameter 8119 AUTOCHNG LEVEL.</p> <p>0 = NOT SEL. 1 = TIMED FUNC 1 – Enables autochange when Timed function 1 is active. 2...4 = TIMED FUNC 2...4 – Enables autochange when Timed function 2...4 is active.</p>
8127	<p>MOTORS</p> <p>Sets the actual number of PFC controlled motors (maximum 7 motors, 1 speed regulated, 3 connected direct-on-line and 3 spare motors).</p> <ul style="list-style-type: none"> • This value includes also the speed regulated motor. • This value must be compatible with the number of relays allocated to PFC if the Autochange function is used. • If Autochange function is not used, the speed regulated motor does not need to have a relay output allocated to PFC but it needs to be included in this value.
8128	<p>AUX START ORDER</p> <p>Sets the start order of the auxiliary motors.</p> <p>1 = EVEN RUNTIME – Time sharing is active. Evens out the cumulative run time of the auxiliary motors. The start order depends on the run time: The auxiliary motor whose cumulative run time is shortest is started first, then the motor whose cumulative run time is the second shortest etc. When the demand drops, the first motor to be stopped is the one whose cumulative run time is longest.</p> <p>2 = RELAY ORDER – The start order is fixed to be the order of the relays.</p>

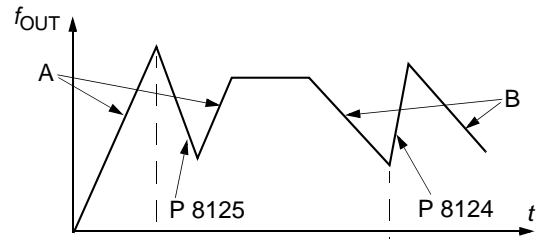

- A = speed regulated motor accelerating using [Group 22: ACCEL/DECEL](#) parameters (2202 or 2205).
- B = speed regulated motor decelerating using [Group 22: ACCEL/DECEL](#) parameters (2203 or 2206).
- At aux. motor start, speed regulated motor decelerates using 8125 DEC IN AUX START.
- At aux. motor stop, speed regulated motor accelerates using 8124 ACC IN AUX STOP.

Group 98: OPTIONS

This group configures for options, in particular, enabling serial communication with the drive.

Code	Description
9802	<p>COMM PROT SEL</p> <p>Selects the communication protocol.</p> <p>0 = NOT SEL – No communication protocol selected.</p> <p>1 = STD MODBUS – The drive communicates with Modbus via the RS485 channel (X1-communications, terminal).</p> <ul style="list-style-type: none">• See also Group 53: EFB PROTOCOL. <p>4 = EXT FBA – The drive communicates via a fieldbus adapter module in option slot 2 of the drive.</p> <ul style="list-style-type: none">• See also Group 51: EXT COMM MODULE. <p>5 = BACNET – Enables fieldbus communication with the drive using BACnet protocol via the RS485 serial link (X1-communications terminal).</p>

Embedded fieldbus

Overview

The ACQ550 can be set up to accept control from an external system using standard serial communication protocols. When using serial communication, the ACQ550 can either:

- Receive all of its control information from the fieldbus, or
- Be controlled from some combination of fieldbus control and other available control locations, such as digital or analog inputs, and the control panel.

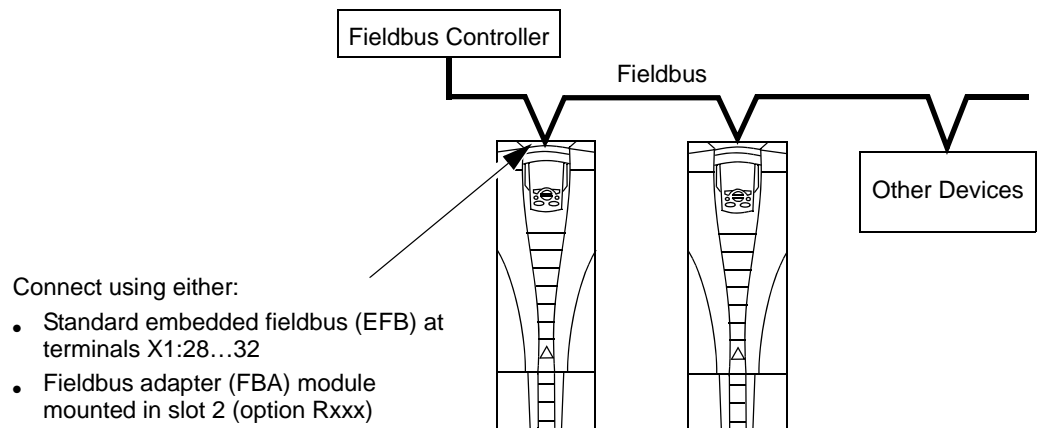

Two basic serial communications configurations are available:

- Embedded fieldbus (EFB) – Using the RS485 interface at terminals X1:28...32 on the control board, a control system can communicate with the drive using any of the following protocols:
 - Modbus®
 - BACnet®
- Fieldbus adapter (FBA) – See section [Fieldbus adapter](#) on page 229.

Control interface

In general, the basic control interface between the fieldbus system and the drive consists of:

Protocol	Control Interface	Reference for more information
Modbus	<ul style="list-style-type: none"> • Output Words <ul style="list-style-type: none"> – Control word – Reference1 – Reference2 • Input Words <ul style="list-style-type: none"> – Status word – Actual value 1 – Actual value 2 – Actual value 3 – Actual value 4 – Actual value 5 – Actual value 6 – Actual value 7 – Actual value 8 	The content of these words is defined by profiles. For details on the profiles used, see ABB control profiles technical data
BACnet	<ul style="list-style-type: none"> • Device management • Binary output objects • Analog output objects • Binary input objects • Analog input objects 	BACnet protocol technical data

Note: The words “output” and “input” are used as seen from the fieldbus controller point of view. For example an output describes data flow from the fieldbus controller to the drive and appears as an input from the drive point of view.

Planning

Network planning should address the following questions:

- What types and quantities of devices must be connected to the network?
- What control information must be sent down to the drives?
- What feedback information must be sent from the drives to the controlling system?

Mechanical and electrical installation – EFB



Warning! Connections should be made only while the drive is disconnected from the power source.

Drive terminals 28...32 are for RS485 communications.

- Use Belden 9842 or equivalent. Belden 9842 is a dual twisted, shielded pair cable with a wave impedance of 120 Ω .
- Use one of these twisted shielded pairs for the RS485 link. Use this pair to connect all A (-) terminals together and all B (+) terminals together.
- Use one of the wires in the other pair for the reference/common (terminal 31), leaving one wire unused.
- Do not directly ground the RS485 network at any point. Ground all devices on the network using their corresponding earthing terminals.
- As always, the grounding wires should not form any closed loops, and all the devices should be earthed to a common ground.
- Connect the RS485 link in a daisy-chained bus, without dropout lines.
- To reduce noise on the network, terminate the RS485 network using 120 Ω resistors at both ends of the network. Use the DIP switch to connect or disconnect the termination resistors. See following wiring diagram. The ACQ550 termination resistor (J-2) are active terminators. This active circuit includes bins (“Pull-up” and “Pull-down”) resistors.
- Connect the shield at each end of the cable to a drive. On one end, connect the shield to terminal 28, and on the other end connect to terminal 32. Do not connect the incoming and outgoing cable shields to the same terminals, as that would make the shielding continuous.
- For configuration information see the following:
 - [Communication setup – EFB](#) on page 181.
 - [Activate drive control functions – EFB](#) on page 185.
 - The appropriate EFB protocol specific technical data. For example, [Modbus protocol technical data](#) on page 197.

Preferred wiring diagram

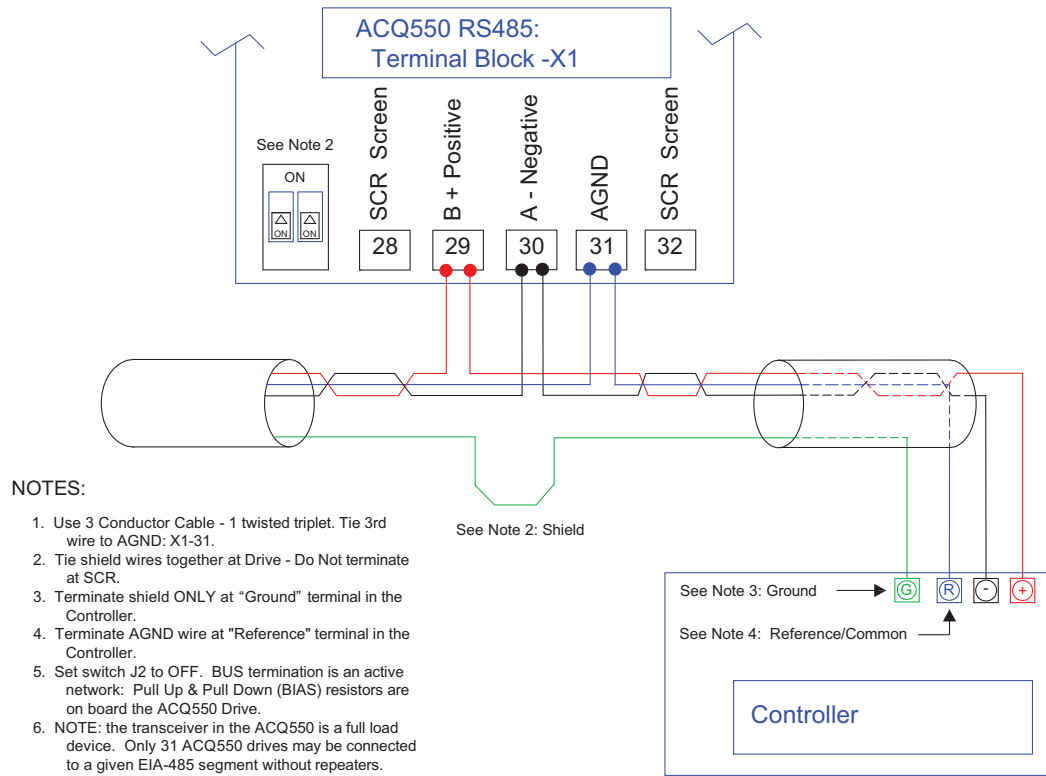

Alternate wiring diagram

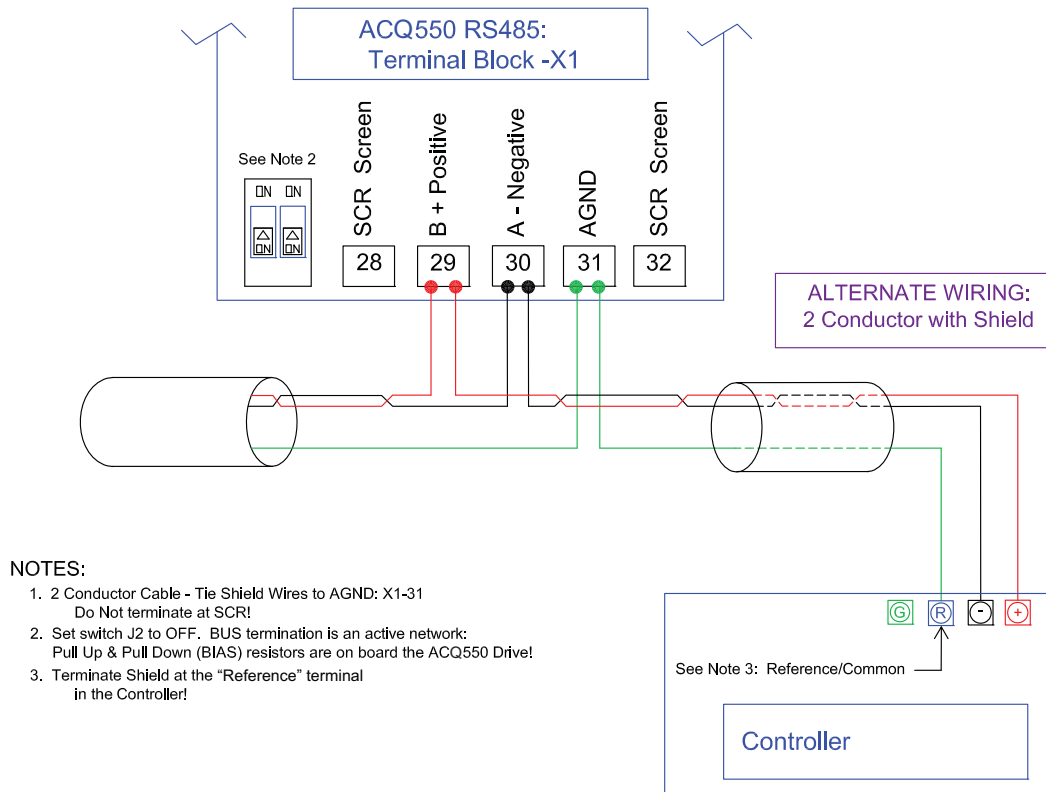

Communication setup – EFB

Serial communication selection

To activate the serial communication, set parameter 9802 COMM PROTOCOL SEL =

- 1 (STD MODBUS).
- 5 (BACNET)

Note: If you cannot see the desired selection on the panel, your drive does not have that protocol software in the application memory.

Serial communication configuration

Setting 9802 automatically sets the appropriate default values in parameters that define the communication process. These parameters and descriptions are defined below. In particular, note that the station ID may require adjustment.

Code	Description	EFB Protocol Reference	
		Modbus	BACnet
5301	EFB PROTOCOL ID Contains the identification and program revision of the protocol.	Do not edit. Any non-zero value entered for parameter 9802 COMM PROT SEL, sets this parameter automatically. The format is: XXYY, where xx = protocol ID, and YY = program revision.	
5302	EFB STATION ID Defines the node address of the RS485 link.	When one of these protocols is selected, the default value for this parameter is: 1	When this protocol is selected, the default value for this parameter is: 128
		Set each drive on the network with a unique value for this parameter. Note: For a new address to take affect, the drive power must be cycled OR 5302 must first be set to 0 before selecting a new address. Leaving 5302 = 0 places the RS485 channel in reset, disabling communication.	

Note: For the BACnet protocol, the ACQ550 will function as a Master with MAC IDs in the range of 1 - 127. With MAC ID settings of 128 - 254, the drive is in Slave only behavior.

Code	Description	EFB Protocol Reference	
		Modbus	BACnet
5303	<p>EFB BAUD RATE</p> <p>Defines the communication speed of the RS485 link in kbits per second (kbits/s).</p> <p>1.2 kbits/s 2.4 kbits/s 4.8 kbits/s 9.6 kbits/s 19.2 kbits/s 38.4 kbits/s 57.6 kbits/s 76.8 kbits/s</p>	When this protocol is selected, the default value for this parameter is: 9.6	When this protocol is selected, the default value for this parameter is: 38400
5304	<p>EFB PARITY</p> <p>Defines the data length, parity and stop bits to be used with the RS485 link communication.</p> <ul style="list-style-type: none"> The same settings must be used in all on-line stations. <p>0 = 8N1 – 8 data bits, No parity, one stop bit. 1 = 8N2 – 8 data bits, No parity, two stop bits. 2 = 8E1 – 8 data bits, Even parity, one stop bit. 3 = 8O1 – 8 data bits, Odd parity, one stop bit.</p>	When this protocol is selected, the default value for this parameter is: 1	When this protocol is selected, the default value for this parameter is: 0 Do not edit.
5305	<p>EFB CTRL PROFILE</p> <p>Selects the communication profile used by the EFB protocol.</p> <p>0 = ABB DRV LIM – Operation of Control/Status Words conform to ABB Drives Profile (limited), as used in ACQ550. 1 = DCU PROFILE – Operation of Control/Status Words conform to 32-bit DCU Profile. 2 = ABB DRV FULL – Operation of Control/Status Words conform to ABB Drives Profile (full).</p>	When this protocol is selected, the default value for this parameter is: 0	N/A. When this protocol is selected, the default value for this parameter is: 0 Changing the value for this parameter has no affect on this protocol's behavior.
5306	EFB OK MESSAGES	This parameter indicates the number of valid application messages received at this drive. This count does not include MS/TP token passing and polling messages. (For such messages, see 5316).	
5307	EFB CRC ERRORS	This parameter indicates the number of CRC errors detected, in either the header or data CRCs.	
5308	EFB UART ERRORS	This parameter indicates the number of UART-related errors (framing, parity) detected.	

Code	Description	EFB Protocol Reference	
		Modbus	BACnet
5309	EFB STATUS	<p>This parameter indicates the internal status of the EFB Protocol as follows:</p> <ul style="list-style-type: none"> • IDLE – EFB Protocol is configured but not receiving messages. • TIMEOUT – Time between valid messages has exceeded the interval set by parameter 3019. • OFFLINE – EFB Protocol is receiving messages NOT addressed to this drive. • ONLINE – EFB Protocol is receiving messages addressed to this drive. • RESET – EFB Protocol is in reset. • LISTEN ONLY – EFB Protocol is in listen-only mode. 	
5310	EFB PAR10	Not used for Comm setup.	Sets the response turnaround time in milliseconds in addition to any fixed delay imposed by the protocol. When this protocol is selected, the default value is: 5 ms
5311	EFB PAR11	Not used for Comm setup.	<p>This parameter, together with parameter 5317, EFB PAR 17, sets BACnet Device Object Instance IDs:</p> <ul style="list-style-type: none"> • For the range 1 to 65,535: This parameter sets the ID directly (5317 must be 0). For example, the following values set the ID to 49134: 5311 = 49134 and 5317 = 0. • For IDs > 65,335: The ID equals 5311's value plus 10,000 times 5317's value. For example, the following values set the ID to 71234: 5311 = 1234 and 5317 = 7.
5314	EFB PAR14	Not used for Comm setup.	
5315	EFB PAR15	Not used for Comm setup.	
5316	EFB PAR 16	Not used for Comm setup.	This parameter indicates the count of MS/TP tokens passed to this drive.

Code	Description	EFB Protocol Reference	
		Modbus	BACnet
5317	EFB PAR17		This parameter works with parameter 5311 to set BACnet Device Object Instance IDs. See parameter 5311.

Note: After any changes to the communication settings, protocol must be reactivated by either cycling the drive power, or by setting parameter 5302 EFB STATION ID to 0 and then restoring the station ID (5302) or use Reinitialize Device Service.

Activate drive control functions – EFB

Controlling the drive

Fieldbus control of various drive functions requires configuration to:

- Tell the drive to accept fieldbus control of the function.
- Define as a fieldbus input, any drive data required for control.
- Define as a fieldbus output, any control data required by the drive.

The following sections describe, at a general level, the configuration required for each control function. For the protocol-specific details, see the document supplied with the FBA module.

Start/stop direction control

Using the fieldbus for start/stop/direction control of the drive requires:

- Drive parameter values set as defined below.
- Fieldbus controller supplied command(s) in the appropriate location. (The location is defined by the Protocol Reference, which is protocol dependent.)

Note: EXT1 = REF1 typically used for follower;
EXT2 = REF2 typically used for PID setpoint.

Drive Parameter		Value	Description	Protocol Reference		
				Modbus ¹		BACnet
				ABB DRV	DCU PROFILE	
1001	EXT1 COMMANDS	10 (COMM)	Start/Stop by fieldbus with Ext1 selected.	40001 bits 0...3	40031 bits 0, 1	BV10
1002	EXT2 COMMANDS	10 (COMM)	Start/Stop by fieldbus with Ext2 selected.	40001 bits 0...3	40031 bits 0, 1	BV10
1003	DIRECTION	3 (REQUEST)	Direction by fieldbus.	4002/ 4003 ²	40031 bit 3	BV11

1. For Modbus, the protocol reference can depend on the profile used, hence two columns in these tables. One column refers to the ABB Drives profile, selected when parameter 5305 = 0 (ABB DRV LIM) or 5305 = 2 (ABB DRV FULL). The other column refers to the DCU profile selected when parameter 5305 = 1 (DCU PROFILE). See [ABB control profiles technical data](#) section.
2. The reference provides direction control – a negative reference provides reverse rotation.

Input reference select

Using the fieldbus to provide input references to the drive requires:

- Drive parameter values set as defined below.
- Fieldbus controller supplied reference word(s) in the appropriate location. (The location is defined by the Protocol Reference, which is protocol dependent.)

Drive Parameter		Value	Setting	Protocol Reference		
				Modbus		BACnet
				ABB DRV	DCU PROFILE	
1102	EXT1/EXT2 SEL	8 (COMM)	Reference set selection by fieldbus.	40001 bit 11	40031 bit 5	BV13
1103	REF1 SEL	8 (COMM)	Input reference 1 by fieldbus.	40002		AV16
1106	REF2 SEL	8 (COMM)	Input reference 2 by fieldbus.	40003		AV17

Reference scaling

Where required, REFERENCES can be scaled. See the following, as appropriate:

- Modbus Register [40002](#) in the [Modbus protocol technical data](#) section.
- [Reference scaling](#) in the [ABB control profiles technical data](#) section.

Miscellaneous drive control

Using the fieldbus for miscellaneous drive control requires:

- Drive parameter values set as defined below.
- Fieldbus controller supplied reference word(s) in the appropriate location. (The location is defined by the Protocol Reference, which is protocol dependent.)

Drive Parameter		Value	Setting	Protocol Reference		
				Modbus		BACnet
				ABB DRV	DCU PROFILE	
1601	RUN ENABLE	7 (COMM) (Not Recommended)	Run enable by fieldbus.	40001 bit 3	40031 bit 6 (inverted)	BV12
1604	FAULT RESET SEL	8 (COMM)	Fault reset by fieldbus.	40001 bit 7	40031 bit 4	BV14
1606	LOCAL LOCK	8 (COMM)	Source for local lock selection is the fieldbus.	Does not apply	40031 bit 14	
1607	PARAM SAVE	1 (SAVE)	Saves altered parameters to memory (then value returns to 0).	41607	40032 bit 2	
1608	START ENABLE 1	7 (COMM) (Not Recommended)	Source for start enable 1 is the fieldbus Command word.	Does not apply.	40032 bit 2	BV20
1609	START ENABLE 2	7 (COMM) (Not Recommended)	Source for start enable 2 is the fieldbus Command word.		40032 bit 3	BV21
2013	MIN TORQUE SEL	7 (COMM)	Source for minimum torque selection is the fieldbus.		40031 bit 15	
2014	MAX TORQUE SEL	7 (COMM)	Source for maximum torque selection is the fieldbus.			
2201	ACC/DEC 1/2 SEL	7 (COMM)	Source for ramp pair selection is the fieldbus.		40031 bit 10	

Relay output control

Using the fieldbus for relay output control requires:

- Drive parameter values set as defined below.
- Fieldbus controller supplied reference word(s) in the appropriate location. (The location is defined by the Protocol Reference, which is protocol dependent.)

Drive Parameter		Value	Setting	Protocol Reference		
				Modbus		BACnet
				ABB DRV	DCU PROFILE	
1401	RELAY OUTPUT 1	35 (COMM)	Relay Output 1 controlled by fieldbus.	40134 bit 0 or 00033	BO0	
1402	RELAY OUTPUT 2	35 (COMM)	Relay Output 2 controlled by fieldbus.	40134 bit 1 or 00034	BO1	
1403	RELAY OUTPUT 3	35 (COMM)	Relay Output 3 controlled by fieldbus.	40134 bit 2 or 00035	BO2	
1410 ¹	RELAY OUTPUT 4	35 (COMM)	Relay Output 4 controlled by fieldbus.	40134 bit 3 or 00036	BO3	
1411 ¹	RELAY OUTPUT 5	35 (COMM)	Relay Output 5 controlled by fieldbus.	40134 bit 4 or 00037	BO4	
1412 ¹	RELAY OUTPUT 6	35 (COMM)	Relay Output 6 controlled by fieldbus.	40134 bit 5 or 00038	BO5	

1. More than 3 relays requires the addition of a relay extension module.

For example: To control relays 1 and 2 using serial communication:
Set parameters 1401 RELAY OUTPUT 1 and 1402 RELAY OUTPUT 1 = 35 (COMM).

Note: Relay status feedback occurs without configuration as defined below.

Drive Parameter		Value	Setting	Protocol Reference		
				Modbus		BACnet
				ABB DRV	DCU PROFILE	
0122	RO 1-3 STATUS	Relay 1...3 status.	40122	0122	BI0... BI2	
0123	RO 4-6 STATUS	Relay 4...6 status.	40123	0123	BI3... BI5	

Analog output control

Using the fieldbus for analog output control requires:

- Drive parameter values set as defined below.
- Fieldbus controller supplied reference word(s) in the appropriate location. (The location is defined by the Protocol Reference, which is protocol dependent.)

Drive Parameter		Value	Setting	Protocol Reference		
				Modbus		BACnet
				ABB DRV	DCU PROFILE	
1501	AO1 CONTENT SEL	135 (COMM VALUE 1)	Analog Output 1 controlled by writing to parameter 0135.	–	–	
0135	COMM VALUE 1	–		40135	AO0	
1507	AO2 CONTENT SEL	136 (COMM VALUE 2)	Analog Output 2 controlled by writing to parameter 0136.	–	–	
0136	COMM VALUE 2	–		40136	AO1	

PID control setpoint source

Use the following settings to select the fieldbus as the setpoint source for PID loops:

Drive Parameter		Value	Setting	Protocol Reference		
				Modbus		BACnet
				ABB DRV	DCU PROFILE	
4010	SET POINT SEL (Set 1)	8 (COMM VALUE 1)	Setpoint is either: <ul style="list-style-type: none"> • Input Reference 2 (+/-/* AI1). Control requires parameter 1106 value = comm. • Process PID setpoint. Control requires parameter 1106 value = pid1 out and parameter 4010 value = comm. 	40003	AV17	
4110	SET POINT SEL (Set 2)	9 (COMM + AI1)				
4210	SET POINT SEL (Ext/ Trim)	10 (COMM*AI1)				

Communication fault

When using fieldbus control, specify the drive's action if serial communication is lost.

Drive Parameter		Value	Description
3018	COMM FAULT FUNC	0 (NOT SEL) 1 (FAULT) 2 (CONST SP7) 3 (LAST SPEED)	Set for appropriate drive response.
3019	COMM FAULT TIME	Set time delay before acting on a communication loss.	

Feedback from the drive – EFB

Pre-defined feedback

Inputs to the controller (drive outputs) have pre-defined meanings established by the protocol. This feedback does not require drive configuration. The following table lists a sample of feedback data. For a complete listing, see input word/point/object listings in the technical data for the appropriate protocol starting on page 197.

Drive Parameter		Protocol Reference	
		Modbus	BACnet
0102	SPEED	40102	AV0
0103	FREQ OUTPUT	40103	AV1
0104	CURRENT	40104	AV4
0105	TORQUE	40105	AV5
0106	POWER	40106	AV6
0107	DC BUS VOLT	40107	AV2
0109	OUTPUT VOLTAGE	40109	AV3
0115	KWH COUNTER	40115	AV8
0118	DI1-3 STATUS – bit 1 (DI3)	40118	BI6, BI7, BI8
0122	RO1-3 STATUS	40122	BI0, BI1, BI2
0301	FB STATUS WORD – bit 0 (STOP)	40301 bit 0	BV0
0301	FB STATUS WORD – bit 2 (REV)	40301 bit 2	BV1

Note: With Modbus, any parameter can be accessed using the format: 4 followed by the parameter number.

Mailbox read/write

The ACQ550 provides a “Mailbox” function to access parameters that have not been pre-defined by the protocol. Using mailbox, any drive parameter can be identified and read. Mailbox can also be used to adjust parameter settings by writing a value to any parameter identified. The following table describes the use of this function.

Name	Description	Protocol Reference	
		Modbus ¹	BACnet
Mailbox Parameter	Enter the number of the drive parameter to access.	Does not apply.	AV25
Mailbox Data	Contains the parameter value after a read, or enter the desired parameter value for a write.		AV26
Mailbox Read	A binary value triggers a read – the value of the “Mailbox Parameter” appears in “Mailbox data”.		BV15
Mailbox Write	A binary value triggers a write – the drive value for the “Mailbox Parameter” changes to the value in “Mailbox data”.		BV16

- As noted above, Modbus provides direct access to all parameters using the format: 4 followed by the parameter number.

Actual value scaling

The scaling of actual values can be protocol dependent. In general, for Actual Values, scale the feedback integer using the parameter's resolution. (See [Complete parameter descriptions](#) section for parameter resolutions.) For example:

Feedback Integer	Parameter Resolution	(Feedback Integer) * (Parameter Resolution) = Scaled Value
1	0.1 mA	1 * 0.1 mA = 0.1 mA
10	0.1%	10 * 0.1% = 1%

Where parameters are in percent, the [Complete parameter descriptions](#) section specifies what parameter corresponds to 100%. In such cases, to convert from percent to engineering units, multiply by the value of the parameter that defines 100% and divide by 100%. For example:

Feedback Integer	Parameter Resolution	Value of the Parameter that defines 100%	(Feedback Integer) * (Parameter Resolution) * (Value of 100% Ref.) / 100% = Scaled Value
10	0.1%	1500 rpm ¹	10 * 0.1% * 1500 RPM / 100% = 15 rpm
100	0.1%	500 Hz ²	100 * 0.1% * 500 Hz / 100% = 50 Hz

1. Assuming, for the sake of this example, that the Actual Value uses parameter 9908 MOT NOM SPEED as the 100% reference, and that 9908 = 1500 rpm.
2. Assuming, for the sake of this example, that the Actual Value uses parameter 9907 MOT NOM FREQ as the 100% reference, and that 9907 = 500 Hz.

Scaling does not apply for the BACnet protocol.

Diagnostics – EFB

Fault queue for drive diagnostics

For general ACQ550 diagnostics information, see [Diagnostics](#) on page 251. The three most recent ACQ550 faults are reported to the fieldbus as defined below. For specific ACQ550 fault codes, see [Fault listing](#) on page 252.

Drive Parameter		Protocol Reference	
		Modbus	BACnet
0401	Last Fault	40401	AV18
0412	Previous Fault 1	40402	AV19
0413	Previous Fault 2	40403	AV20

Serial communication diagnostics

Network problems can be caused by multiple sources. Some of these sources are:

- Loose connections
- Incorrect wiring (including swapped wires)
- Bad grounding
- Duplicate station numbers
- Incorrect setup of drives or other devices on the network

The major diagnostic features for fault tracing on an EFB network include Group 53 EFB Protocol parameters 5306...5309. The [Complete parameter descriptions](#) section describes these parameters in detail.

Diagnostic situations

The sub-sections below describe various diagnostic situations – the problem symptoms and corrective actions.

Normal operation

During normal network operation, 5306...5309 parameter values act as follows at each drive:

- 5306 EFB OK MESSAGES advances (advances for each application message properly received and addressed to this drive).
- 5307 EFB CRC ERRORS does not advance at all (advances when an invalid message CRC is received).
- 5308 EFB UART ERRORS does not advance at all (advances when character format errors are detected, such as parity or framing errors).
- 5309 EFB status value varies depending on network traffic.
- BACnet protocol: 5316 EFB PAR 16 (MS/TP token counter) advances for each token passed to this drive. (Does not apply for other protocols.)

Loss of communication

The action taken by the ACQ550, if communication is lost, is configured in [Communication fault](#). The parameters are 3018 COMM FAULT FUNC and 3019 COMM FAULT TIME. The [Complete parameter descriptions](#) section on page 83 describes these parameters.

No master station on line

If no master station is on line: Neither the EFB OK MESSAGES nor the errors (5307 EFB CRC ERRORS and 5308 EFB UART ERRORS) increase on any of the stations.

To correct:

- Check that a network master is connected and properly programmed on the network.
- Verify that the cable is connected, and is not cut or short circuited.

Duplicate stations

If two or more stations have duplicate numbers:

- Two or more drives cannot be addressed.
- Every time there is a read or write to one particular station, the value for 5307 EFB CRC ERRORS or 5308 EFB UART ERRORS advances.

To correct: Check all station numbers and edit conflicting values.

Swapped wires

If the communication wires are swapped (terminal A on one drive is connected to terminal B on another):

- The value of 5306 EFB OK MESSAGES does not advance.
- The values of 5307 EFB CRC ERRORS and 5308 EFB UART ERRORS are advancing.

To correct: Check that the EIA-485 lines are not swapped.

Fault 28 – Serial 1 Err

If the drive's control panel shows fault code 28 "SERIAL 1 ERR", check for either of the following:

- The master system is down. To correct, resolve problem with master system.
- The communication connection is bad. To correct, check communication connection at the drive.
- The time-out selection for the drive is too short for the given installation. The master is not polling the drive within the specified time-out delay. To correct, increase the time set by parameter 3019 COMM FAULT TIME.

Fault 31 – EFB1

For BACnet: If the drive's control panel shows fault code 31 "EFB1", the drive has an invalid Device Object Instance ID. To correct, use parameters 5311 and 5317 and establish a unique drive ID that is in the range 1 to 4,194,303.

Faults 31...33 – EFB1...EFB3

Except as noted above, these three EFB fault codes (listed for the drive in [Diagnostics](#) on page [251](#), fault codes 31...33) are not used.

Intermittent off-line occurrences

The problems described above are the most common problems encountered with ACQ550 serial communication. Intermittent problems might also be caused by:

- Marginally loose connections,
- Wear on wires caused by equipment vibrations,
- Insufficient grounding and shielding on both the devices and on the communication cables.
- Two conductor wire (plus shield) is in use instead of the recommended three conductor wire (plus shield), see page [180](#).

Troubleshooting

The troubleshooting table below should be followed in order from top to bottom by parameter number. Begin the troubleshooting process by displaying the first parameter in the table (5308) and determining if the display on the panel exhibits the symptom. If it does, review the possible cause(s) and take the necessary corrective action(s). Once the symptom for this parameter is eliminated, continue to the next parameter and repeat the process until you have reached the end.

Parameter Number	Display on Panel (Symptom)	Possible Cause	Corrective Action
5308 UART ERRORS	Rapidly Increasing Numeric Value ¹	<ol style="list-style-type: none"> 1. Duplicate Addresses 2. Swapped Wires 3. Incorrect Baud Rate 4. Incorrect Parity 5. Too many devices on wire 6. Incorrect Bias 7. Noise on EIA-485 wire 8. Blown EIA-485 transceiver 	<ol style="list-style-type: none"> 1. Ensure EFB PROTOCOL parameters 5302 [also 5311 & 5317 when using BACnet] are unique. 5302 must be a unique address on the segment. [5311 & 5317 must be unique addresses on the network when using BACnet.] 2. Swap wires B(+) & A(-). 3. Adjust parameter 5303 & Cycle power. 4. Change parity using parameter 5304 & cycle power. 5. Limit to 31 devices on 1 segment. 6. Turn off VFD termination resistors (move jumpers). Install loose resistor recommended by the DCS controls company. (Terminate final device on the trunk.) 7. Install EIA-485 (3 conductor shielded) data grade cable communications wire. See drawings on page 180. 8. Find and correct ground loop or high voltage problems before replacing any component assemblies. Perform the following steps to determine if the EIA-485 transceiver is damaged. <ol style="list-style-type: none"> a. Power unit down. b. Remove bus wires and retighten connections. c. Turn bus termination ON. d. Measure impedance between B(+) & A(-). ACQ550 164 ohms +/- 5% If measurements are not within the specified range the EIA-485 transceiver is bad, replace the assembly containing the EIA-485 port.
5307 (5007) DV CRC ERR	Rapidly Increasing Numeric Value ¹	<ol style="list-style-type: none"> 1. Duplicate Addresses 2. Too many devices on wire 3. Noise on EIA-485 wire 	<ol style="list-style-type: none"> 1. See Corrective Action 1. Parameter Number 5308 2. Limit to 31 unit loads on 1 segment (ACQ550 = 1 unit load) 3. See Corrective Action 7. Parameter Number 5308

Parameter Number	Display on Panel (Symptom)	Possible Cause	Corrective Action
5309 (5009) DV STATUS	IDLE	<ol style="list-style-type: none"> 1. No network connection 2. Blown EIA-485 transceiver 	<ol style="list-style-type: none"> 1. Land communication wires as shown in drawings on page 180. Check Repeater (if installed onsite). 2. See Corrective Action 8. Parameter Number 5308.
5316 (5016) DV PAR 16 (BACnet Only)	Not Increasing Numeric Value	<ol style="list-style-type: none"> 1. Drive device address parameter 5302 is set to 128 or greater. 2. Max Masters is set too low on all drives. 	<ol style="list-style-type: none"> 1. Change parameter 5302 to a unique value below 128. 2. Change Max Masters property at all devices on bus to 127.
5306 (5006) DV OK MSG	OK Message Counter not increasing ¹	<ol style="list-style-type: none"> 1. Master/Client not communicating with drive. 2. Failed router 	<ol style="list-style-type: none"> 1. Add device and points to the building control system. 2. Replace router.

1. Reset by pressing UP & DOWN arrows simultaneously in edit mode. Save change by pressing ENTER.

Modbus protocol technical data

Overview

The Modbus® protocol was introduced by Modicon, Inc. for use in control environments featuring Modicon programmable controllers. Due to its ease of use and implementation, this common PLC language was quickly adopted as a de-facto standard for integration of a wide variety of master controllers and slave devices.

Modbus is a serial, asynchronous protocol. Transactions are half-duplex, featuring a single Master controlling one or more Slaves. While RS232 can be used for point-to-point communication between a single Master and a single Slave, a more common implementation features a multi-drop RS485 network with a single Master controlling multiple Slaves. The ACQ550 features RS485 for its Modbus physical interface.

RTU

The Modbus specification defines two distinct transmission modes: ASCII and RTU. The ACQ550 supports RTU only.

Feature summary

The following Modbus function codes are supported by the ACQ550.

Function	Code (Hex)	Description
Read Coil Status	0x01	Read discrete output status. For the ACQ550, the individual bits of the control word are mapped to Coils 1...16. Relay outputs are mapped sequentially beginning with Coil 33 (e.g. RO1=Coil 33).
Read Discrete Input Status	0x02	Read discrete inputs status. For the ACQ550, the individual bits of the status word are mapped to Inputs 1...16 or 1...32, depending on the active profile. Terminal inputs are mapped sequentially beginning with Input 33 (e.g. DI1=Input 33).
Read Multiple Holding Registers	0x03	Read multiple holding registers. For the ACQ550, the entire parameter set is mapped as holding registers, as well as command, status and reference values.
Read Multiple Input Registers	0x04	Read multiple input registers. For the ACQ550, the 2 analog input channels are mapped as input registers 1 & 2.
Force Single Coil	0x05	Write a single discrete output. For the ACQ550, the individual bits of the control word are mapped to Coils 1...16. Relay outputs are mapped sequentially beginning with Coil 33 (e.g. RO1=Coil 33).
Write Single Holding Register	0x06	Write single holding register. For the ACQ550, the entire parameter set is mapped as holding registers, as well as command, status and reference values.
Diagnostics	0x08	Perform Modbus diagnostics. Subcodes for Query (0x00), Restart (0x01) & Listen Only (0x04) are supported.
Force Multiple Coils	0x0F	Write multiple discrete outputs. For the ACQ550, the individual bits of the control word are mapped to Coils 1...16. Relay outputs are mapped sequentially beginning with Coil 33 (e.g. RO1=Coil 33).
Write Multiple Holding Registers	0x10	Write multiple holding registers. For the ACQ550, the entire parameter set is mapped as holding registers, as well as command, status and reference values.
Read/Write Multiple Holding Registers	0x17	This function combines functions 0x03 and 0x10 into a single command.

Mapping summary

The following table summarizes the mapping between the ACQ550 (parameters and I/O) and Modbus reference space. For details, see [Modbus addressing](#) below.

ACQ550	Modbus reference	Supported function codes
<ul style="list-style-type: none"> Control Bits Relay Outputs 	Coils(0xxxx)	<ul style="list-style-type: none"> 01 – Read Coil Status 05 – Force Single Coil 15 – Force Multiple Coils
<ul style="list-style-type: none"> Status Bits Discrete Inputs 	Discrete Inputs(1xxxx)	<ul style="list-style-type: none"> 02 – Read Input Status
<ul style="list-style-type: none"> Analog Inputs 	Input Registers(3xxxxx)	<ul style="list-style-type: none"> 04 – Read Input Registers
<ul style="list-style-type: none"> Parameters Control/Status Words References 	Holding Registers(4xxxx)	<ul style="list-style-type: none"> 03 – Read 4X Registers 06 – Preset Single 4X Register 16 – Preset Multiple 4X Registers 23 – Read/Write 4X Registers

Communication profiles

When communicating by Modbus, the ACQ550 supports multiple profiles for control and status information. Parameter 5305 EFB CTRL PROFILE selects the profile used.

- ABB DRV LIM – The primary (and default) profile is the ABB DRV LIM profile. This implementation of the ABB Drives profile standardizes the control interface with ACS400 drives. The ABB Drives profile is based on the PROFIBUS interface. It is discussed in detail in the following sections.
- DCU PROFILE – The DCU PROFILE profile extends the control and status interface to 32 bits. It is the internal interface between the main drive application and the embedded fieldbus environment.
- ABB DRV FULL – ABB DRV FULL is the implementation of the ABB Drives profile that standardizes the control interface with ACS600 and ACS800 drives. This implementation supports two control word bits not supported by the ABB DRV LIM implementation.

Modbus addressing

With Modbus, each function code implies access to a specific Modbus reference set. Thus, the leading digit is not included in the address field of a Modbus message.

Note: The ACQ550 supports the zero-based addressing of the Modbus specification. Holding register 40002 is addressed as 0001 in a Modbus message. Similarly, coil 33 is addressed as 0032 in a Modbus message.

Refer again to the [Mapping summary](#) above. The following sections describe, in detail, the mapping to each Modbus reference set.

0xxxx Mapping – Modbus coils. The drive maps the following information to the 0xxxx Modbus set called Modbus Coils:

- bit-wise map of the CONTROL WORD (selected using parameter 5305 EFB CTRL PROFILE). The first 32 coils are reserved for this purpose.

- relay output states, numbered sequentially beginning with coil 00033.

The following table summarizes the 0xxxx reference set:

Modbus ref.	Internal location (all profiles)	ABB DRV LIM (5305 = 0)	DCU PROFILE (5305 = 1)	ABB DRV FULL (5305 = 2)
00001	CONTROL WORD – Bit 0	OFF1 ¹	STOP	OFF1 ¹
00002	CONTROL WORD – Bit 1	OFF2 ¹	START	OFF2 ¹
00003	CONTROL WORD – Bit 2	OFF3 ¹	REVERSE	OFF3 ¹
00004	CONTROL WORD – Bit 3	START	LOCAL	START
00005	CONTROL WORD – Bit 4	N/A	RESET	RAMP_OUT_ZERO ¹
00006	CONTROL WORD – Bit 5	RAMP_HOLD ¹	EXT2	RAMP_HOLD ¹
00007	CONTROL WORD – Bit 6	RAMP_IN_ZERO ¹	RUN_DISABLE	RAMP_IN_ZERO ¹
00008	CONTROL WORD – Bit 7	RESET	STPMODE_R	RESET
00009	CONTROL WORD – Bit 8	N/A	STPMODE_EM	N/A
00010	CONTROL WORD – Bit 9	N/A	STPMODE_C	N/A
00011	CONTROL WORD – Bit 10	N/A	RAMP_2	REMOTE_CMD ¹
00012	CONTROL WORD – Bit 11	EXT2	RAMP_OUT_0	EXT2
00013	CONTROL WORD – Bit 12	N/A	RAMP_HOLD	N/A
00014	CONTROL WORD – Bit 13	N/A	RAMP_IN_0	N/A
00015	CONTROL WORD – Bit 14	N/A	REQ_LOCALLOCK	N/A
00016	CONTROL WORD – Bit 15	N/A	TORQLIM2	N/A
00017	CONTROL WORD – Bit 16	Does not apply	FBLOCAL_CTL	Does not apply
00018	CONTROL WORD – Bit 17		FBLOCAL_REF	
00019	CONTROL WORD – Bit 18		START_DISABLE1	
00020	CONTROL WORD – Bit 19		START_DISABLE2	
00021... 00032	Reserved	Reserved	Reserved	Reserved
00033	RELAY OUTPUT 1	Relay Output 1	Relay Output 1	Relay Output 1
00034	RELAY OUTPUT 2	Relay Output 2	Relay Output 2	Relay Output 2
00035	RELAY OUTPUT 3	Relay Output 3	Relay Output 3	Relay Output 3
00036	RELAY OUTPUT 4	Relay Output 4	Relay Output 4	Relay Output 4
00037	RELAY OUTPUT 5	Relay Output 5	Relay Output 5	Relay Output 5
00038	RELAY OUTPUT 6	Relay Output 6	Relay Output 6	Relay Output 6

¹ = Active low

For the 0xxxx registers:

- Status is always readable.
- Forcing is allowed by user configuration of the drive for fieldbus control.
- Additional relay outputs are added sequentially.

The ACQ550 supports the following Modbus function codes for coils:

Function code	Description
01	Read coil status
05	Force single coil
15 (0x0F Hex)	Force multiple coils

1xxxx Mapping – Modbus discrete inputs. The drive maps the following information to the 1xxxx Modbus set called Modbus Discrete Inputs:

- bit-wise map of the STATUS WORD (selected using parameter 5305 EFB CTRL PROFILE). The first 32 inputs are reserved for this purpose.
- discrete hardware inputs, numbered sequentially beginning with input 33.

The following table summarizes the 1xxxx reference set:

Modbus ref.	Internal location (all profiles)	ABB DRV (5305 = 0 OR 2)	DCU PROFILE (5305 = 1)
10001	STATUS WORD – Bit 0	RDY_ON	READY
10002	STATUS WORD – Bit 1	RDY_RUN	ENABLED
10003	STATUS WORD – Bit 2	RDY_REF	STARTED
10004	STATUS WORD – Bit 3	TRIPPED	RUNNING
10005	STATUS WORD – Bit 4	OFF_2_STA ¹	ZERO_SPEED
10006	STATUS WORD – Bit 5	OFF_3_STA ¹	ACCELERATE
10007	STATUS WORD – Bit 6	SWC_ON_INHIB	DECELERATE
10008	STATUS WORD – Bit 7	ALARM	AT_SETPOINT
10009	STATUS WORD – Bit 8	AT_SETPOINT	LIMIT
10010	STATUS WORD – Bit 9	REMOTE	SUPERVISION
10011	STATUS WORD – Bit 10	ABOVE_LIMIT	REV_REF
10012	STATUS WORD – Bit 11	EXT2	REV_ACT
10013	STATUS WORD – Bit 12	RUN_ENABLE	PANEL_LOCAL
10014	STATUS WORD – Bit 13	N/A	FIELDBUS_LOCAL
10015	STATUS WORD – Bit 14	N/A	EXT2_ACT
10016	STATUS WORD – Bit 15	N/A	FAULT
10017	STATUS WORD – Bit 16	Reserved	ALARM
10018	STATUS WORD – Bit 17	Reserved	REQ_MAINT
10019	STATUS WORD – Bit 18	Reserved	DIRLOCK
10020	STATUS WORD – Bit 19	Reserved	LOCALLOCK
10021	STATUS WORD – Bit 20	Reserved	CTL_MODE
10022	STATUS WORD – Bit 21	Reserved	Reserved
10023	STATUS WORD – Bit 22	Reserved	Reserved
10024	STATUS WORD – Bit 23	Reserved	Reserved
10025	STATUS WORD – Bit 24	Reserved	Reserved
10026	STATUS WORD – Bit 25	Reserved	Reserved
10027	STATUS WORD – Bit 26	Reserved	REQ_CTL

Modbus ref.	Internal location (all profiles)	ABB DRV (5305 = 0 OR 2)	DCU PROFILE (5305 = 1)
10028	STATUS WORD – Bit 27	Reserved	REQ_REF1
10029	STATUS WORD – Bit 28	Reserved	REQ_REF2
10030	STATUS WORD – Bit 29	Reserved	REQ_REF2EXT
10031	STATUS WORD – Bit 30	Reserved	ACK_STARTINH
10032	STATUS WORD – Bit 31	Reserved	ACK_OFF_ILCK
10033	DI1	DI1	DI1
10034	DI2	DI2	DI2
10035	DI3	DI3	DI3
10036	DI4	DI4	DI4
10037	DI5	DI5	DI5
10038	DI6	DI6	DI6

¹ = Active low

For the 1xxxx registers:

- Additional discrete inputs are added sequentially.

The ACQ550 supports the following Modbus function codes for discrete inputs:

Function code	Description
02	Read input status

3xxxx Mapping – Modbus inputs. The drive maps the following information to the 3xxxx Modbus addresses called Modbus input registers:

- any user defined analog inputs.

The following table summarizes the input registers:

Modbus reference	ACQ550 all profiles	Remarks
30001	AI1	This register shall report the level of Analog Input 1 (0...100%).
30002	AI2	This register shall report the level of Analog Input 2 (0...100%).

The ACQ550 supports the following Modbus function codes for 3xxxx registers:

Function code	Description
04	Read 3xxxx input status

4xxxx Register mapping. The drive maps its parameters and other data to the 4xxxx holding registers as follows:

- 40001...40099 map to drive control and actual values. These registers are described in the table below.
- 40101...49999 map to drive parameters 0101...9999. Register addresses that do not correspond to drive parameters are invalid. If there is an attempt to read or write outside the parameter addresses, the Modbus interface returns an exception code to the controller.

The following table summarizes the 4xxxx drive control registers 40001...40099 (for 4xxxx registers above 40099, see the drive parameter list, e.g. 40102 is parameter 0102):

Modbus register		Access	Remarks
40001	CONTROL WORD	R/W	Maps directly to the profile's CONTROL WORD. Supported only if 5305 = 0 or 2 (ABB Drives profile). Parameter 5319 holds a copy in hex format.
40002	Reference 1	R/W	Range = 0...+20000 (scaled to 0...1105 REF1 MAX), or -20000...0 (scaled to 1105 REF1 MAX...0).
40003	Reference 2	R/W	Range = 0...+10000 (scaled to 0...1108 REF2 MAX), or -10000...0 (scaled to 1108 REF2 MAX...0).
40004	STATUS WORD	R	Maps directly to the profile's STATUS WORD. Supported only if 5305 = 0 or 2 (ABB Drives profile). Parameter 5320 holds a copy in hex format.
40005	Actual 1 (select using 5310)	R	By default, stores a copy of 0103 OUTPUT FREQ. Use parameter 5310 to select a different actual value for this register.
40006	Actual 2 (select using 5311)	R	By default, stores a copy of 0104 CURRENT. Use parameter 5311 to select a different actual value for this register.
40007	Actual 3 (select using 5312)	R	By default, stores nothing. Use parameter 5312 to select an actual value for this register.
40008	Actual 4 (select using 5313)	R	By default, stores nothing. Use parameter 5313 to select an actual value for this register.
40009	Actual 5 (select using 5314)	R	By default, stores nothing. Use parameter 5314 to select an actual value for this register.
40010	Actual 6 (select using 5315)	R	By default, stores nothing. Use parameter 5315 to select an actual value for this register.
40011	Actual 7 (select using 5316)	R	By default, stores nothing. Use parameter 5316 to select an actual value for this register.
40012	Actual 8 (select using 5317)	R	By default, stores nothing. Use parameter 5317 to select an actual value for this register.
40031	ACQ550 CONTROL WORD LSW	R/W	Maps directly to the Least Significant Word of the DCU profile's CONTROL WORD. Supported only if 5305 = 1. See parameter 0301.
40032	ACQ550 CONTROL WORD MSW	R	Maps directly to the Most Significant Word of the DCU profile's CONTROL WORD. Supported only if 5305 = 1. See parameter 0302.
40033	ACQ550 STATUS WORD LSW	R	Maps directly to the Least Significant Word of the DCU profile's STATUS WORD. Supported only if 5305 = 1. See parameter 0303.
40034	ACQ550 STATUS WORD MSW	R	Maps directly to the Most Significant Word of the DCU profile's STATUS WORD. Supported only if 5305 = 1. See parameter 0304.

For the Modbus protocol, drive parameters in [Group 53: EFB PROTOCOL](#) report the parameter mapping to 4xxxx Registers.

Code	Description
5310	EFB PAR 10 Specifies the parameter mapped to Modbus register 40005.
5311	EFB PAR 11 Specifies the parameter mapped to Modbus register 40006.
5312	EFB PAR 12 Specifies the parameter mapped to Modbus register 40007.
5313	EFB PAR 13 Specifies the parameter mapped to Modbus register 40008.
5314	EFB PAR 14 Specifies the parameter mapped to Modbus register 40009.
5315	EFB PAR 15 Specifies the parameter mapped to Modbus register 40010.
5316	EFB PAR 16 Specifies the parameter mapped to Modbus register 40011.
5317	EFB PAR 17 Specifies the parameter mapped to Modbus register 40012.
5318	EFB PAR 18 Sets additional delay in milliseconds before the ACQ550 begins transmitting response to the master request.
5319	EFB PAR 19 Holds a copy (in hex) of the CONTROL WORD, Modbus register 40001.
5320	EFB PAR 20 Holds a copy (in hex) of the STATUS WORD, Modbus register 40004.

Except where restricted by the drive, all parameters are available for both reading and writing. The parameter writes are verified for the correct value and for a valid register addresses.

Note: Parameter writes through standard Modbus are always volatile i.e. modified values are not automatically stored to permanent memory. Use parameter 1607 PARAM SAVE to save all altered values.

The ACQ550 supports the following Modbus function codes for 4xxxx registers:

Function code	Description
03	Read holding 4xxxx registers
06	Preset single 4xxxx register
16 (0x10 Hex)	Preset multiple 4xxxx registers
23 (0x17 Hex)	Read/write 4xxxx registers

Actual values

The contents of the register addresses 40005...40012 are ACTUAL VALUES and are:

- specified using parameters 5310...5317
- Read-only values containing information on the operation of the drive
- 16-bit words containing a sign bit and a 15-bit integer
- when negative values, written as the two's complement of the corresponding positive value
- scaled as described earlier in section [Actual value scaling](#) on page 191.

Exception codes

Exception codes are serial communication responses from the drive. The ACQ550 supports the standard Modbus exception codes defined below.

Exception code	Name	Meaning
01	ILLEGAL FUNCTION	Unsupported Command
02	ILLEGAL DATA ADDRESS	The data address received in the query is not allowable. It is not a defined parameter/group.
03	ILLEGAL DATA VALUE	A value contained in the query data field is not an allowable value for the ACQ550, because it is one of the following: <ul style="list-style-type: none"> • Outside min. or max. limits. • Parameter is read-only. • Message is too long. • Parameter write not allowed when start is active. • Parameter write not allowed when factory macro is selected.

ABB control profiles technical data

Overview

ABB Drives profile

The ABB Drives profile provides a standard profile that can be used on multiple protocols, including Modbus and the protocols available on the FBA module. Two implementations of the ABB Drives profile are available:

- ABB DRV FULL – This implementation standardizes the control interface with ACQ600 and ACQ800 drives.
- ABB DRV LIM – This implementation standardizes the control interface with ACQ400 drives. This implementation does not support two control word bits supported by ABB DRV FULL.

Except as noted, the following “ABB Drives Profile” descriptions apply to both implementations.

DCU profile

The DCU profile extends the control and status interface to 32 bits. It is the internal interface between the main drive application and the embedded fieldbus environment.

Control Word

The CONTROL WORD is the principal means for controlling the drive from a fieldbus system. The fieldbus master station sends the CONTROL WORD to the drive. The drive switches between states according to the bit-coded instructions in the CONTROL WORD. Using the CONTROL WORD requires that:

- The drive is in remote (REM) control.
- The serial communication channel is defined as the source for controlling commands (set using parameters such as 1001 EXT1 COMMANDS, 1002 EXT2 COMMANDS and 1102 EXT1/EXT2 SEL).
- The serial communication channel used is configured to use an ABB control profile. For example, to use the control profile ABB DRV FULL requires both parameter 9802 COMM PROT SEL = 1 (STD MODBUS) and parameter 5305 EFB CTRL PROFILE = 2 (ABB DRV FULL).

ABB Drives profile

The following table and the state diagram later in this sub-section describe the CONTROL WORD content for the ABB Drives profile.

ABB Drives profile CONTROL WORD (See parameter 5319)				
Bit	Name	Value	Commanded state	Comments
0	OFF1 CONTROL	1	READY TO OPERATE	Enter READY TO OPERATE
		0	EMERGENCY OFF	Drive ramps to stop according to currently active deceleration ramp (2203 or 2205) Normal command sequence: <ul style="list-style-type: none"> • Enter OFF1 ACTIVE • Proceed to READY TO SWITCH ON, unless other interlocks (OFF2, OFF3) are active.
1	OFF2 CONTROL	1	OPERATING	Continue operation (OFF2 inactive)
		0	EMERGENCY OFF	Drive coasts to stop. Normal command sequence: <ul style="list-style-type: none"> • Enter OFF2 ACTIVE • Proceed to SWITCHON INHIBITED
2	OFF3 CONTROL	1	OPERATING	Continue operation (OFF3 inactive)
		0	EMERGENCY STOP	Drive stops within time specified by parameter 2208. Normal command sequence: <ul style="list-style-type: none"> • Enter OFF3 ACTIVE • Proceed to SWITCH ON INHIBITED  WARNING! Be sure motor and driven equipment can be stopped using this mode.
3	INHIBIT OPERATION	1	OPERATION ENABLED	Enter OPERATION ENABLED (Note the Run enable signal must be active. See 1601. If 1601 is set to COMM, this bit also activates the Run Enable signal.)
		0	OPERATION INHIBITED	Inhibit operation. Enter OPERATION INHIBITED
4	Unused (ABB DRV LIM)			
	RAMP_OUT_ZERO (ABB DRV FULL)	1	NORMAL OPERATION	Enter RAMP FUNCTION GENERATOR: ACCELERATION ENABLED
0		RFG OUT ZERO	Force ramp function generator output to Zero. Drive ramps to stop (current and DC voltage limits in force).	
5	RAMP_HOLD	1	RFG OUT ENABLED	Enable ramp function. Enter RAMP FUNCTION GENERATOR: ACCELERATOR ENABLED
		0	RFG OUT HOLD	Halt ramping (Ramp Function Generator output held)
6	RAMP_IN_ZERO	1	RFG INPUT ENABLED	Normal operation. Enter OPERATING
		0	RFG INPUT ZERO	Force Ramp Function Generator input to zero.

ABB Drives profile CONTROL WORD (See parameter 5319)				
Bit	Name	Value	Commanded state	Comments
7	RESET	0=>1	RESET	Fault reset if an active fault exists (Enter SWITCH-ON INHIBITED). Effective if 1604 = COMM.
		0	OPERATING	Continue normal operation
8...9	Unused			
10	Unused (ABB DRV LIM)			
	REMOTE_CMD (ABB DRV FULL)	1		Fieldbus control enabled.
		0		<ul style="list-style-type: none"> CW ≠ 0 or Ref ≠ 0: Retain last CW and Ref. CW = 0 and Ref = 0: Fieldbus control enabled. Ref and deceleration/acceleration ramp are locked.
11	EXT CTRL LOC	1	EXT2 SELECT	Select external control location 2 (EXT2). Effective if 1102 = COMM.
		0	EXT1 SELECT	Select external control location 1 (EXT1). Effective if 1102 = COMM.
12...15	Unused			

DCU Profile

The following tables describe the CONTROL WORD content for the DCU profile.

DCU profile CONTROL WORD (See parameter 0301)				
Bit	Name	Value	Command/Req.	Comments
0	STOP	1	Stop	Stops according to either the stop mode parameter or the stop mode requests (bits 7 and 8).
		0	(no op)	
1	START	1	Start	Simultaneous STOP and START commands result in a stop command.
		0	(no op)	
2	REVERSE	1	Reverse direction	This bit XOR'd with the sign of the reference defines direction.
		0	Forward direction	
3	LOCAL	1	Local mode	When the fieldbus sets this bit, it steals control and the drive moves to fieldbus local control mode.
		0	External mode	
4	RESET	-> 1	Reset	Edge sensitive.
		other	(no op)	
5	EXT2	1	Switch to EXT2	
		0	Switch to EXT1	
6	RUN_DISABLE	1	Run disable	Inverted run enable.
		0	Run enable on	
7	STPMODE_R	1	Normal ramp stop mode	
		0	(no op)	

DCU profile CONTROL WORD (See parameter 0301)				
Bit	Name	Value	Command/Req.	Comments
8	STPMODE_EM	1	Emergency ramp stop mode	
		0	(no op)	
9	STPMODE_C	1	Coast stop mode	
		0	(no op)	
10	RAMP_2	1	Ramp pair 2	
		0	Ramp pair 1	
11	RAMP_OUT_0	1	Ramp output to 0	
		0	(no op)	
12	RAMP_HOLD	1	Ramp freeze	
		0	(no op)	
13	RAMP_IN_0	1	Ramp input to 0	
		0	(no op)	
14	RREQ_LOCALL OC	1	Local mode lock	In lock, drive will not switch to local mode.
		0	(no op)	
15	TORQLIM2	1	Torque limit pair 2	
		0	Torque limit pair 1	

DCU profile CONTROL WORD (See parameter 0302)				
Bit	Name	Value	Function	Comments
16...26	Reserved			
27	REF_CONST	1	Constant speed ref.	These bits are only for supervision purposes.
		0	(no op)	
28	REF_AVE	1	Average speed ref.	
		0	(no op)	
29	LINK_ON	1	Master is detected in link	
		0	Link is down	
30	REQ_STARTINH	1	Start inhibit request is pending	
		0	Start inhibit request is OFF	
31	OFF_INTERLOCK	1	Panel OFF button pressed	For the control panel (or PC tool) this is the OFF button interlock.
		0	(no op)	

Status Word

The contents of the STATUS WORD is status information, sent by the drive to the master station.

ABB Drives profile

The following table and the state diagram later in this sub-section describe the STATUS WORD content for the ABB Drives profile.

ABB Drives profile (EFB) STATUS WORD (See parameter 5320)			
Bit	Name	Value	Description (Correspond to states/boxes in the state diagram)
0	RDY_ON	1	READY TO SWITCH ON
		0	NOT READY TO SWITCH ON
1	RDY_RUN	1	READY TO OPERATE
		0	OFF1 ACTIVE
2	RDY_REF	1	OPERATION ENABLED
		0	OPERATION INHIBITED
3	TRIPPED	0...1	FAULT
		0	No fault
4	OFF_2_STA	1	OFF2 INACTIVE
		0	OFF2 ACTIVE
5	OFF_3_STA	1	OFF3 INACTIVE
		0	OFF3 ACTIVE
6	SWC_ON_INHIB	1	SWITCH-ON INHIBIT ACTIVE
		0	SWITCH-ON INHIBIT NOT ACTIVE
7	ALARM	1	Alarm (See section Alarm listing on page 258 for details on alarms.)
		0	No alarm
8	AT_SETPOINT	1	OPERATING. Actual value equals (within tolerance limits) the reference value.
		0	Actual value is outside tolerance limits (not equal to reference value).
9	REMOTE	1	Drive control location: REMOTE (EXT1 or EXT2)
		0	Drive control location: LOCAL
10	ABOVE_LIMIT	1	Supervised parameter's value \geq supervision high limit. Bit remains "1" until supervised parameter's value < supervision low limit. See Group 32: SUPERVISION .
		0	Supervised parameter's value < supervision low limit. Bit remains "0" until supervised parameter's value > supervision high limit. See Group 32: SUPERVISION .
11	EXT CTRL LOC	1	External control location 2 (EXT2) selected
		0	External control location 1 (EXT1) selected
12	EXT RUN ENABLE	1	External Run Enable signal received
		0	No External Run Enable signal received
13... 15	Unused		

DCU profile

The following tables describe the STATUS WORD content for the DCU profile.

DCU profile STATUS WORD (See parameter 0303)			
Bit	Name	Value	Status
0	READY	1	Drive is ready to receive start command.
		0	Drive is not ready.
1	ENABLED	1	External run enable signal received.
		0	No external run enable signal received.
2	STARTED	1	Drive has received start command.
		0	Drive has not received start command.
3	RUNNING	1	Drive is modulating.
		0	Drive is not modulating.
4	ZERO_SPEED	1	Drive is at zero speed.
		0	Drive has not reached zero speed.
5	ACCELERATE	1	Drive is accelerating.
		0	Drive is not accelerating.
6	DECELERATE	1	Drive is decelerating.
		0	Drive is not decelerating.
7	AT_SETPOINT	1	Drive is at setpoint.
		0	Drive has not reached setpoint.
8	LIMIT	1	Operation is limited by Group 20: LIMITS settings.
		0	Operation is within Group 20: LIMITS settings.
9	SUPERVISION	1	A supervised parameter (Group 32: SUPERVISION) is outside its limits.
		0	All supervised parameters are within limits.
10	REV_REF	1	Drive reference is in reverse direction.
		0	Drive reference is in forward direction.
11	REV_ACT	1	Drive is running in reverse direction.
		0	Drive is running in forward direction.
12	PANEL_LOCAL	1	Control is in control panel (or PC tool) local mode.
		0	Control is not in control panel local mode.
13	FIELDBUS_LOCAL	1	Control is in fieldbus local mode (steals control panel local).
		0	Control is not in fieldbus local mode.
14	EXT2_ACT	1	Control is in EXT2 mode.
		0	Control is in EXT1 mode.
15	FAULT	1	Drive is in a fault state.
		0	Drive is not in a fault state.

DCU profile STATUS WORD (See parameter 0304)			
Bit	Name	Value	Status
16	ALARM	1	An alarm is on.
		0	No alarms are on.
17	REQ_MAINT	1	A maintenance request is pending.
		0	No maintenance request is pending.
18	DIRLOCK	1	Direction lock is ON. (Direction change is locked out.)
		0	Direction lock is OFF.
19	LOCALLOCK	1	Local mode lock is ON. (Local mode is locked out.)
		0	Local mode lock is OFF.
20	CTL_MODE	1	Drive is in vector control mode.
		0	Drive is in scalar control mode.
21...25	Reserved		
26	REQ_CTL	1	Copy the control word
		0	(no op)
27	REQ_REF1	1	Reference 1 requested in this channel.
		0	Reference 1 is not requested in this channel.
28	REQ_REF2	1	Reference 2 requested in this channel.
		0	Reference 2 is not requested in this channel.
29	REQ_REF2EXT	1	External PID reference 2 requested in this channel.
		0	External PID reference 2 is not requested in this channel.
30	ACK_STARTINH	1	A start inhibit from this channel is granted.
		0	A start inhibit from this channel is not granted.
31	ACK_OFF_ILCK	1	Start inhibit due to OFF button
		0	Normal operation

State diagram

ABB Drives profile

To illustrate the operation of the state diagram, the following example (ABB DRV LIM implementation of the ABB Drives profile) uses the control word to start the drive:

- First, the requirements for using the CONTROL WORD must be met. See above.
- When the power is first connected, the state of the drive is not ready to switch on. See dotted lined path (---) in the state diagram below.
- Use the CONTROL WORD to step through the state machine states until the OPERATING state is reached, meaning that the drive is running and follows the given reference. See the table below.

Step	CONTROL WORD Value	Description
1	CW = 0000 0000 0000 0110 bit 15 bit 0	This CW value changes the drive state to READY TO SWITCH ON.
2		Wait at least 100 ms before proceeding.
3	CW = 0000 0000 0000 0111	This CW value changes the drive state to READY TO OPERATE.
4	CW = 0000 0000 0000 1111	This CW value changes the drive state to OPERATION ENABLED. The drive starts, but will not accelerate.
5	CW = 0000 0000 0010 1111	This CW value releases the ramp function generator (RFG) output and changes the drive state to RFG: ACCELERATOR ENABLED.
6	CW = 0000 0000 0110 1111	This CW value releases the ramp function generator (RFG) output and changes the drive state to OPERATING. The drive accelerates to the given reference and follows the reference.

The state diagram below describes the start-stop function of CONTROL WORD (CW) and STATUS WORD (SW) bits for the ABB Drives profile.

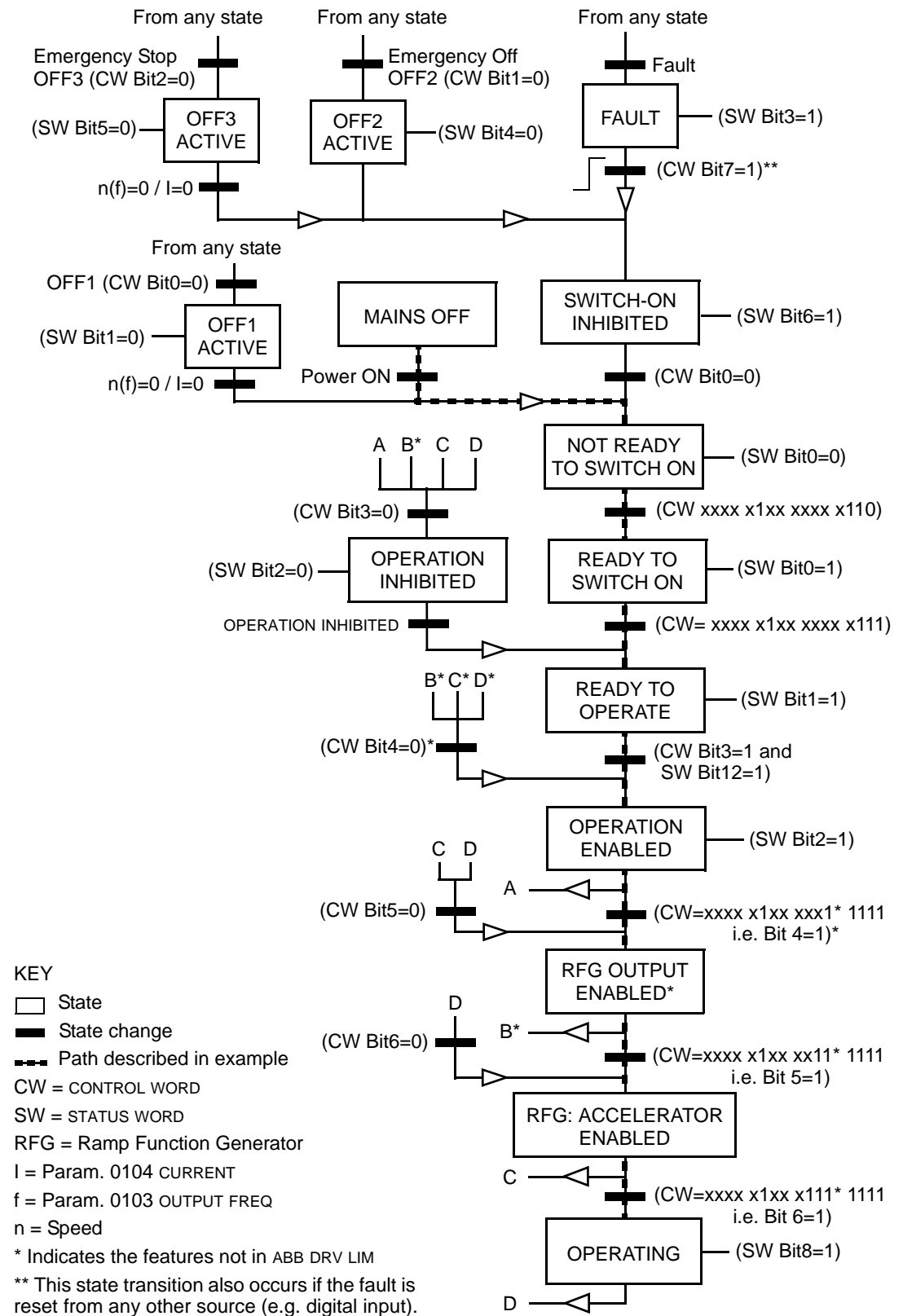

Reference scaling

ABB Drives and DCU profiles

The following table describes REFERENCE scaling for the ABB Drives and DCU profiles.

ABB Drives and DCU profiles				
Reference	Range	Reference type	Scaling	Remarks
REF1	-32767 ... +32767	Speed or frequency	-20000 = -(par. 1105) 0 = 0 +20000 = (par. 1105) (20000 corresponds to 100%)	Final reference limited by 1104/1105. Actual motor speed limited by 2001/2002 (speed) or 2007/2008 (frequency).
REF2	-32767 ... +32767	Speed or frequency	-10000 = -(par. 1108) 0 = 0 +10000 = (par. 1108) (10000 corresponds to 100%)	Final reference limited by 1107/1108. Actual motor speed limited by 2001/2002 (speed) or 2007/2008 (frequency).
		Torque	-10000 = -(par. 1108) 0 = 0 +10000 = (par. 1108) (10000 corresponds to 100%)	Final reference limited by 2015/2017 (torque1) or 2016/2018 (torque2).
		PID Reference	-10000 = -(par. 1108) 0 = 0 +10000 = (par. 1108) (10000 corresponds to 100%)	Final reference limited by 4012/4013 (PID set1) or 4112/4113 (PID set2).

Note: The setting of parameter 1104 REF1 MIN and 1107 REF2 MIN has no effect on the scaling of references.

When parameter 1103 REF1 SELECT or 1106 REF2 SELECT is set to COMM+AI1 or COMM*AI1, the reference is scaled as follows:

ABB Drives and DCU profiles		
Reference	Value setting	AI reference scaling
REF1	COMM+AI1	$\text{COMM (\%)} + (\text{AI (\%)} - 0.5 \cdot \text{REF1 MAX (\%)})$

ABB Drives and DCU profiles		
Reference	Value setting	AI reference scaling
REF1	COMM*AI1	$\text{COMM (\%)} \cdot (\text{AI (\%)} / 0.5 \cdot \text{REF1 MAX (\%)})$ <p>(100 - 0.5 · (par. 1105))%</p>
REF2	COMM+AI1	$\text{COMM (\%)} + (\text{AI (\%)} - 0.5 \cdot \text{REF2 MAX (\%)})$ <p>(100 + 0.5 · (Par. 1108))%</p> <p>(100 - 0.5 · (par. 1108))%</p>
REF2	COMM*AI1	$\text{COMM (\%)} \cdot (\text{AI (\%)} / 0.5 \cdot \text{REF2 MAX (\%)})$

Reference handling

Use [Group 10: START/STOP/DIR](#) parameters to configure for control of rotation direction for each control location (EXT1 and EXT2). The following diagrams illustrate how group 10 parameters and the sign of the fieldbus reference interact to produce REFERENCE values (REF1 and REF2). Note, fieldbus references are bipolar, that is they can be positive or negative.

ABB Drives profile		
Parameter	Value setting	AI reference scaling
1003 DIRECTION	1 (FORWARD)	
1003 DIRECTION	2 (REVERSE)	
1003 DIRECTION	3 (REQUEST)	

BACnet protocol technical data

Binary input object instance summary

The following table summarizes the Binary Input Objects supported:

Instance ID	Object Name	Description	Active/ Inactive Text	Present Value Access Type
BI0	RO 1 ACT	This object indicates the status of Relay Output 1.	ON/OFF	R
BI1	RO 2 ACT	This object indicates the status of Relay Output 2.	ON/OFF	R
BI2	RO 3 ACT	This object indicates the status of Relay Output 3.	ON/OFF	R
BI3	RO 4 ACT	This object indicates the status of Relay Output 4 (requires OREL-01 option).	ON/OFF	R
BI4	RO 5 ACT	This object indicates the status of Relay Output 5 (requires OREL-01 option)	ON/OFF	R
BI5	RO 6 ACT	This object indicates the status of Relay Output 6 (requires OREL-01 option)	ON/OFF	R
BI6	DI 1 ACT	This object indicates the status of Digital Input 1.	ON/OFF	R
BI7	DI 2 ACT	This object indicates the status of Digital Input 2.	ON/OFF	R
BI8	DI 3 ACT	This object indicates the status of Digital Input 3.	ON/OFF	R
BI9	DI 4 ACT	This object indicates the status of Digital Input 4.	ON/OFF	R
BI10	DI 5 ACT	This object indicates the status of Digital Input 5.	ON/OFF	R
BI11	DI 6 ACT	This object indicates the status of Digital Input 6.	ON/OFF	R

Note: For Present Value Access Types, R = Read-only, W = Writeable, C = Commandable. Commandable values support priority arrays & relinquish defaults.

Binary output object instance summary

The following table summarizes the Binary Output Objects supported:

Instance ID	Object Name	Description	Active/ Inactive Text	Present Value Access Type
BO0	RO1 COMMAND	This object controls the output state of Relay 1. This control requires that parameter 1401 value = COMM.	ON/OFF	C
BO1	RO2 COMMAND	This object controls the output state of Relay 2. This control requires that parameter 1402 value = COMM.	ON/OFF	C

Instance ID	Object Name	Description	Active/Inactive Text	Present Value Access Type
BO2	RO3 COMMAND	This object controls the output state of Relay 3. This control requires that parameter 1403 value = COMM.	ON/OFF	C
BO3	RO4 COMMAND	This object controls the output state of Relay 4. This control requires that parameter 1410 value = COMM (also requires OREL-01 option).	ON/OFF	C
BO4	RO5 COMMAND	This object controls the output state of Relay 5. This control requires that parameter 1411 value = COMM (also requires OREL-01 option).	ON/OFF	C
BO5	RO6 COMMAND	This object controls the output state of Relay 6. This control requires that parameter 1412 value = COMM (also requires OREL-01 option).	ON/OFF	C

Note: For Present Value Access Types, R = Read-only, W = Writeable, C = Commandable. Commandable values support priority arrays & relinquish defaults.

Binary value object instance summary

The following table summarizes the Binary Value Objects supported:

Instance ID	Object Name	Description	Active/Inactive Text	Present Value Access Type
BV0	RUN/STOP ACT	This object indicates the drive Run Status, regardless of the control source.	RUN/STOP	R
BV1	FWD/REV ACT	This object indicates the motor's rotation direction, regardless of the control source.	REV/FWD	R
BV2	FAULT ACT	this object indicates the drive's fault status.	FAULT/OK	R
BV3	EXT 1/2 ACT	This object indicates which control source is active: External 1 or External 2.	EXT2/EXT1	R
BV4	HAND/AUTO ACT	This object indicates whether the drive is under Hand or Auto control.	HAND/AUTO	R
BV5	ALARM ACT	This object indicates the drive's alarm status.	ALARM/OK	R
BV6	MAINT REQ	This object indicates the drive's maintenance status. Refer to Group 29 in the drive's parameter descriptions.	MAINT/OK	R
BV7	DRIVE READY	This object indicates whether the drive is ready to accept a run command.	READY/NOT READY	R

Instance ID	Object Name	Description	Active/Inactive Text	Present Value Access Type
BV8	AT SETPOINT	This object indicates whether the drive is at the commanded setpoint.	YES/NO	R
BV9	ENABLE ACT	This object indicates the System Enable command status (the combination of all Run and Start Enables), regardless of the control source.	ENABLE/DISABLE	R
BV10	RUN/STOP CMD	This object commands a drive start. Control requires either: <ul style="list-style-type: none"> Parameter 1001 value = COMM for control by EXT1 or Parameter 1002 value = COMM for control by EXT2. 	RUN/STOP	C
BV11	FWD/REV CMD	This object commands a motor rotation direction change. Control requires 1003 = REQUEST and either: <ul style="list-style-type: none"> Parameter 1001 value = COMM for control by EXT1 or Parameter 1002 value = COMM for control by EXT2. 	REV/FWD	C
BV12	RUN ENA CMD	This object commands Run Enable. Control requires parameter 1601 value = COMM.	ENABLE/DISABLE	C
BV13	EXT 1/2 CMD	This object selects ext1 or ext2 as the active control source. Control requires parameter 1102 value = COMM.	EXT2/EXT1	C
BV14	FAULT RESET	This object resets a faulted drive. The command is rising-edge triggered. Control requires parameter 1604 value = COMM.	RESET/NO	C
BV15	MBOX READ	This object reads a parameter (defined by AV25 MBOX PARAM) and returns it in AV26 MBOX DATA.	READ/RESET	W
BV16	MBOX WRITE	This object writes the data value specified by AV26, MBOX DATA, to a parameter (defined by AV25, MBOX PARAM).	WRITE/RESET	W
BV17	LOCK PANEL	This object locks the panel and prevents parameter changes. The corresponding drive parameter is 1602.	LOCK/UNLOCK	W

Instance ID	Object Name	Description	Active/Inactive Text	Present Value Access Type
BV18	CTL OVERRIDE CMD	This object commands the drive into BACnet Control Override. In this mode, BACnet takes drive control from the normal source. However, the control panel's HAND mode has priority over BACnet Control Override.	ON/OFF	C
BV19	CTL OVERRIDE ACT	This object indicates whether the drive is in BACnet Control Override. (See BV18.)	ON/OFF	R
BV20	START ENABLE 1	This object commands start enable1. Control requires param 1608 value = COMM.	ENABLE/DISABLE	C
BV21	START ENABLE 2	This object commands start enable1. Control requires param 1609 value = COMM.	ENABLE/DISABLE	C

Note: For Present Value Access Types, R = Read-only, W = Writeable, C = Commandable. Commandable values support priority arrays & relinquish defaults.

Analog input object instance summary

The following table summarizes the Analog Input Objects supported:

Instance ID	Object Name	Description	Units	Present Value Access Type
AI0	ANALOG INPUT 1	This object indicates the value of Analog Input 1. The corresponding drive parameter is 0120.	Percent	R
AI1	ANALOG INPUT 2	This object indicates the value of Analog Input 2. The corresponding drive parameter is 0121.	Percent	R

Note: For Present Value Access Types, R = Read-only, W = Writeable, C = Commandable. Commandable values support priority arrays & relinquish defaults.

Analog output object instance summary

The following table summarizes the Analog Output Objects supported:

Instance ID	Object Name	Description	Units	Present Value Access Type
AO0	AO 1 COMMAND	This object controls Analog Output 1. The corresponding drive parameter is 0135, COMM VALUE 1. Control requires parameter 1501 value = 135.	Percent	C

Instance ID	Object Name	Description	Units	Present Value Access Type
AO1	AO 2 COMMAND	This object controls Analog Output 2. The corresponding drive parameter is 0136, COMM VALUE 2. Control requires parameter 1507 value = 136.	Percent	C

Note: For Present Value Access Types, R = Read-only, W = Writeable, C = Commandable. Commandable values support priority arrays & relinquish defaults.

Analog value object instance summary

The following table summarizes the Analog Value Objects supported:

Instance ID	Object Name	Description	Units	Present Value Access Type
AV0	OUTPUT SPEED	This object indicates the calculated motor speed in RPM. The corresponding drive parameter is 0102.	RPM	R
AV1	OUTPUT FREQ	This object indicates the output frequency applied to the motor in Hz. The corresponding drive parameter is 0103.	Hertz	R
AV2	DC BUS VOLT	This object indicates the drive's DC bus voltage level. The corresponding drive parameter is 0107.	Volts	R
AV3	OUTPUT VOLT	This object indicates the AC output voltage applied to the motor. The corresponding drive parameter is 0109.	Volts	R
AV4	CURRENT	This object indicates the measured output current. The corresponding drive parameter is 0104.	Amps	R
AV5	TORQUE	This object indicates the calculated motor output torque as a percentage of nominal torque. The corresponding drive parameter is 0105.	Percent	R
AV6	POWER	This object indicates the measured output power in kW. The corresponding drive parameter is 0106.	Kilowatts	R
AV7	DRIVE TEMP	This object indicates the measured heatsink temperature in °C. The corresponding drive parameter is 0110.	°C	R
AV8	KWH (R)	This object indicates, in kW hours, the drive's accumulated energy usage since the last reset. The value can be reset to zero. The corresponding drive parameter is 0115.	kWh	W
AV9	KWH (NR)	This object indicates the drive's accumulated energy usage in kW hours. The value cannot be reset.	kWh	R
AV10	PRC PID FBCK	This object is the Process PID feedback signal. The corresponding drive parameter is 0130.	Percent	R

Instance ID	Object Name	Description	Units	Present Value Access Type
AV11	PRC PID DEV	This object is the Process PID output signal's deviation from its setpoint. The corresponding drive parameter is 0132.	Percent	R
AV12	EXT PID FBCK	This object is the External PID feedback signal. The corresponding drive parameter is 0131.	Percent	R
AV13	EXT PID DEV	This object is the External PID output signal's deviation from its setpoint. The corresponding drive parameter is 0133.	Percent	R
AV14	RUN TIME (R)	This object indicates, in hours, the drive's accumulated run time since the last reset. The value can be reset to zero. The corresponding drive parameter is 0114.	Hours	W
AV15	MOTOR TEMP	This object indicates the drive's motor temperature, as set up in parameter Group 35. The corresponding drive parameter is 0145.	°C	R
AV16	INPUT REF 1	This object sets Input Reference 1. Control requires parameter 1103 value = COMM.	Percent	C
AV17	INPUT REF 2	This object sets either: <ul style="list-style-type: none"> Input Reference 2. Control requires parameter 1106 value = COMM. Process PID setpoint. Control requires parameter 1106 value = PID1 OUT and parameter 4010 value = COMM. 	Percent	C
AV18	LAST FLT	This object indicates the most recent fault entered in the drive's fault log. The corresponding drive parameter is 0401.	None	R
AV19	PREV FLT 1	This object indicates the second most recent fault entered in the drive's fault log. The corresponding drive parameter is 0412.	None	R
AV20	PREV FLT 2	This object indicates the third most recent fault entered in the drive's fault log. The corresponding drive parameter is 0413.	None	R
AV21	AO 1 ACT	This object indicates Analog Output 1's level. The corresponding drive parameter is 0124.	Milliamps	R
AV22	AO 2 ACT	This object indicates Analog Output 2's level. The corresponding drive parameter is 0125.	Milliamps	R
AV23	ACCEL1 TIME	This object sets the Ramp1 acceleration time. The corresponding drive parameter is 2202.	Seconds	W
AV24	DECEL1 TIME	This object sets the Ramp1 deceleration time. The corresponding drive parameter is 2203.	Seconds	W
AV25	MBOX PARAM	This object defines the parameter to be read or written to by the mailbox function. See BV15 and BV16.	None	W

Instance ID	Object Name	Description	Units	Present Value Access Type
AV26	MBOX DATA	This object holds the mailbox function's parameter value – a value that was read, or is to be written. See BV15 and BV16.	None	W
AV27	EXT PID STPT	This object sets the External PID controller setpoint. The corresponding drive parameter is 4211. Control requires parameter 4210, PID SETPOINT SEL, value = 19 (INTERNAL).	Percent	C

Note: For Present Value Access Types, R = Read-only, W = Writeable, C = Commandable. Commandable values support priority arrays & relinquish defaults.

BACnet quick-start sequence

The following steps summarize the process for enabling and configuring BACnet on the ACQ550:

1. Enable BACnet protocol: Set drive parameter 9802, COMM PROTOCOL SEL = BACNET (5).

Note: If you cannot see the desired selection on the panel, your drive does not have that protocol software in the application memory.

- To confirm this selection, read drive parameter 5301, EFB PROTOCOL ID. It should read x5xx (where “x” is any value).
2. Place the BACnet channel in “reset”: Set drive parameter 5302, EFB STATION ID = 0.
 - This setting holds the BACnet communication channel in reset while remaining settings are completed.
 3. Define the MS/TP baud rate.
 - Set drive parameter 5303, EFB BAUD RATE = appropriate value.
 4. Define the Device Object Instance ID.
 - To define a specific device object instance value, use drive parameters 5311 and 5317 (object instance values must be unique and in the range 1 to 4,194,303).
 - To use the drive's MS/TP MAC ID as the device object instance value, set drive parameter 5311 and 5317 = 0.
 - BACnet requires a unique Device Object ID for each device on the BACnet network.
 5. Define a unique MS/TP MAC ID. Set drive parameter 5302, EFB STATION ID = appropriate value.
 - Once this parameter is set to a non-zero value, current BACnet settings are “latched” and used for communication until the channel is reset.

- In order to participate in MS/TP token passing, the MAC ID used must be within the limits defined by other masters' "Max Master" property.
6. Confirm proper BACnet communication.
 - When BACnet communication is operating properly, drive parameter 5316, EFB PAR 16 (the MS/TP token counter), should be continually increasing.
 - Drive parameter 5306, UART ERRORS, should be stable. (With autobaud detection, this parameter may increase until the proper baud rate is detected.)
 7. Configure the Device Object Name.
 - BACnet requires a unique name for each device on the BACnet network. Write the Object Name of the Device Object of the drive to a unique text string using the operator workstation or software tool capable of writing BACnet properties. The Object Name cannot be modified with the ABB display panel and only the Device Object name is writable in this product. We do not support writing of Device Description.

BACnet Device Address Rules

- MSTP MAC Addresses must be unique for all devices connected to the same RS485 network.
- MSTP MAC Address is configurable via parameter 5302 in ACQ550.
1..127 = range of supported Master addresses for ACQ550
- Network Number must be unique for each network (IP and MSTP)
- Network Number of 0 is reserved for broadcasts
- Device Object IDs must be unique across the entire BACnet network, all IP and MSTP subnetworks.
- Device Object IDs are 22 bits, configurable via parameters 5311 and 5317 in ACQ550.
- The example Network Numbers and DeviceOIDs show a good way to maintain unique Device OIDs across the network.

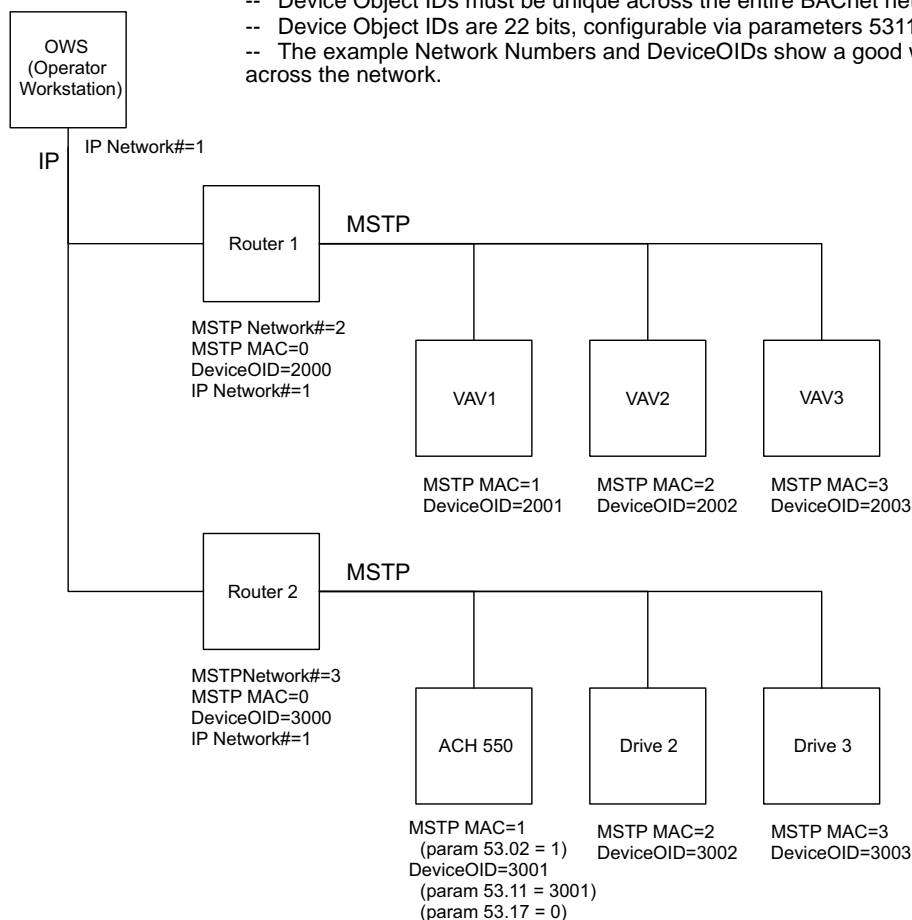

Protocol Implementation Conformance Statement (PICS)

PICS summary

BACnet Standard Device Profile. This version of ACQ550 BACnet fully conforms to the 'Application-Specific Controller' standard device profile (B-ASC).

Services Supported. The following services are supported by the ACQ550:

- I-Am (Response to Who-Is, also broadcast on power-up & other reset)
- I-Have (Response to Who-Has)
- ReadProperty
- WriteProperty
- DeviceCommunicationControl
- ReinitializeDevice

Data Link Layer. The ACQ550 implements MS/TP (Master) Data Link Layer. All standard MS/TP baud rates are supported (9600, 19200, 38400 & 76800).

MAC ID / Device Object Instance. The ACQ550 supports separate MAC ID and Device Object Instance parameters:

- Set the MAC ID using drive parameter 5302. Default: 5302 = 128.
- Set the Device Object Instance ID using drive parameters 5311 and 5317. Default: Both 5311 and 5317 = 0, which causes the MAC ID to “double” as the Device Object Instance. For Device Object Instance values not linked to the MAC ID, set ID values using 5311 and 5317:
 - For IDs in the range 1 to 65,535: Parameter 5311 sets the ID directly (5317 must be 0). For example, the following values set the ID to 49,134:
5311 = 49134 and 5317 = 0.
 - For IDs > 65,335: The ID equals 5311's value plus 10,000 times 5317's value. For example, the following values set the ID to 71,234:
5311 = 1234 and 5317 = 7.

Max Info Frames Property. Configure the Device Object Max Info Frames property using drive parameter 5312. Default: 5312 = 1.

Max Master Property. Configure the Device Object Max Master property using drive parameter 5313. Default: 5313 = 127.

MS/TP token counter

Parameter 5316 stores the count of MS/TP tokens passed to the associated node.

Statement

This statement is part of this Standard and is required for its use.

BACnet Protocol Implementation Conformance Statement	
Date:	February 5, 2009
Vendor Name:	ABB, Inc
Product Name:	Low Voltage AC Motor Drive
Product Model Number:	ACQ550
Applications Software Version:	050F
Firmware Revision:	312B
BACnet Protocol Revision:	4
Product Description:	The ACQ550 is a high-performance adjustable frequency drive specifically designed for water and wastewater applications. This product supports native BACnet, connecting directly to the MS/TP LAN. All standard MS/TP baud rates are supported, as well as master mode functionality. Over BACnet, the drive can be fully controlled as a standard adjustable frequency drive. In addition, up to 16 configurable I/O ports are available over BACnet for user applications.
BACnet Standardized Device Profile (Annex L):	<input type="checkbox"/> BACnet Operator Workstation (B-OWS) <input type="checkbox"/> BACnet Building Controller (B-BC) <input type="checkbox"/> BACnet Advanced Application Controller (B-AAC) <input checked="" type="checkbox"/> BACnet Application Specific Controller (B-ASC) <input type="checkbox"/> BACnet Smart Sensor (B-SS) <input type="checkbox"/> BACnet Smart Actuator (B-SA)
List all BACnet Interoperability Building Blocks Supported (Annex K):	DS-RP-B, DS-WP-B, DM-DDB-B, DM-DOB-B, DM-DCC-B, DM-RD-B.
Segmentation Capability:	<input type="checkbox"/> Segmented requests supported. Window Size ____ <input type="checkbox"/> Segmented responses supported. Window Size ____
Standard Object Types Supported: An object type is supported if it may be present in the device. For each standard Object Type supported provide the following data: 1) Whether objects of this type are dynamically creatable using the CreateObject service 2) Whether objects of this type are dynamically detectable using the DeleteObject service 3) List of the optional properties supported 4) List of all properties that are writable where not otherwise required by this standard 5) List of proprietary properties and for each its property identifier, datatype, and meaning 6) List of any property range restrictions	See table at Object/property support matrix on page 228.

BACnet Protocol Implementation Conformance Statement	
Data Link Layer Options:	<input type="checkbox"/> BACnet IP, (Annex J) <input type="checkbox"/> BACnet IP, (Annex J), Foreign Device <input type="checkbox"/> ISO 8802-3, Ethernet (Clause 7) <input type="checkbox"/> ANSI/ATA 878.1, 2.5 Mb. ARCNET (Clause 8) <input type="checkbox"/> ANSI/ATA 878.1, EIA-485 ARCNET (Clause 8), baud rate(s) ____ <input checked="" type="checkbox"/> MS/TP master (Clause 9), baud rate(s): 9600, 19200, 38400, 76800 <input type="checkbox"/> MS/TP slave (Clause 9), baud rate(s): ____ <input type="checkbox"/> Point-To-Point, EIA 232 (Clause 10), baud rate(s): ____ <input type="checkbox"/> Point-To-Point, modem, (Clause 10), baud rate(s): ____ <input type="checkbox"/> LonTalk, (Clause 11), medium: _____ <input type="checkbox"/> Other: _____
Device Address Binding: Is static device binding supported? (This is currently necessary for two-way communication with MS/TP slaves and certain other devices.)	<input type="checkbox"/> Yes <input checked="" type="checkbox"/> No
Networking Options:	<input type="checkbox"/> Router, Clause 6 - List all routing configurations, e.g., ARCNET-Ethernet, Ethernet-MS/TP, etc. <input type="checkbox"/> Annex H, BACnet Tunneling Router over IP <input type="checkbox"/> BACnet/IP Broadcast Management Device (BBMD)
Does the BBMD support registrations by Foreign Devices?	<input type="checkbox"/> Yes <input type="checkbox"/> No
Character Sets Supported: Indicating support for multiple character sets does not imply that they can all be supported simultaneously.	<input checked="" type="checkbox"/> ANSI X3.4 <input type="checkbox"/> IBM™/Microsoft™ DBCS <input type="checkbox"/> ISO 8859-1 <input type="checkbox"/> ISO 10646 (UCS-2) <input type="checkbox"/> ISO 10646 (UCS-4) <input type="checkbox"/> JIS C 6226
If this product is a communication gateway, describe the types of non-BACnet equipment/network(s) that the gateway supports:	

BACnet Object Definitions

Object/property support matrix

The following table summarizes the Object Types/Properties Supported:

Property	Object Type						
	Device	Binary Input	Binary Output	Binary Value	Analog Input	Analog Output	Analog Value
Object Identifier	✓	✓	✓	✓	✓	✓	✓
Object Name	✓	✓	✓	✓	✓	✓	✓
Object Type	✓	✓	✓	✓	✓	✓	✓
System Status	✓						
Vendor Name	✓						
Vendor Identifier	✓						
Model Name	✓						
Firmware Revision	✓						
Appl Software Revision	✓						
Protocol Version	✓						
Protocol Revision	✓						
Services Supported	✓						
Object Types Supported	✓						
Object List	✓						
Max APDU Length	✓						
Segmentation Support	✓						
APDU Timeout	✓						
Number APDU Retries	✓						
Max Master	✓						
Max Info Frames	✓						
Device Address Binding	✓						
Database Revision	✓						
Present Value		✓	✓	✓	✓	✓	✓
Status Flags		✓	✓	✓	✓	✓	✓
Event State		✓	✓	✓	✓	✓	✓
Out-of-Service		✓	✓	✓	✓	✓	✓
Units					✓	✓	✓
Priority Array			✓	✓*		✓	✓*
Relinquish Default			✓	✓*		✓	✓*
Polarity		✓	✓				
Active Text		✓	✓	✓			
Inactive Text		✓	✓	✓			

* For commandable values only.

Fieldbus adapter

Overview

The ACQ550 can be set up to accept control from an external system using standard serial communication protocols. When using serial communication, the ACQ550 can either:

- receive all of its control information from the fieldbus, or
- be controlled from some combination of fieldbus control and other available control locations, such as digital or analog inputs and the control panel.

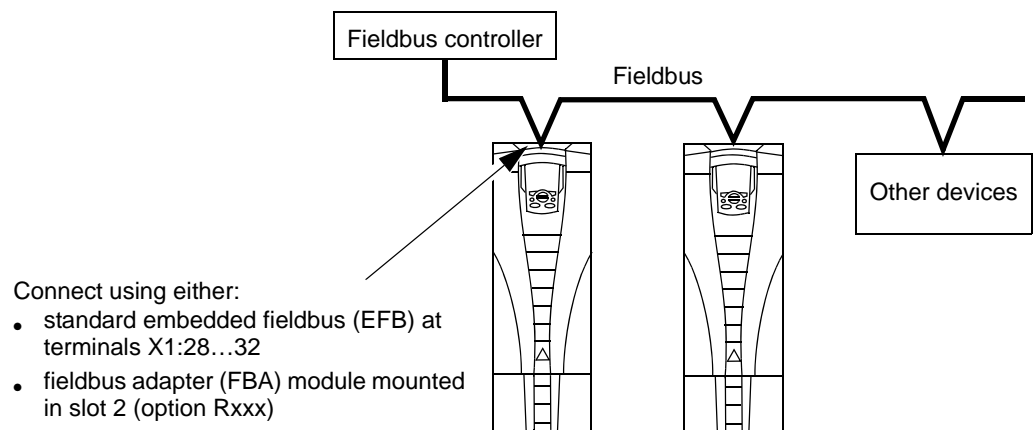

Two basic serial communications configurations are available:

- embedded fieldbus (EFB) – See chapter [Embedded fieldbus](#) on page [177](#).
- fieldbus adapter (FBA) – With one of the optional FBA modules in the drive's expansion slot 2, the drive can communicate to a control system using one of the following protocols:
 - PROFIBUS DP
 - Ethernet (Modbus/TCP, EtherNet/IP™, EtherCAT, PROFINET IO, POWERLINK)
 - CANopen
 - DeviceNet™
 - ControlNet™
 - CC-Link.

The ACQ550 detects automatically which communication protocol is used by the plug-in fieldbus adapter. The default settings for each protocol assume that the profile used is the protocol's industry-standard drive profile (e.g. PROFIdrive for PROFIBUS, AC/DC Drive for DeviceNet). All of the FBA protocols can also be configured for the ABB Drives profile.

Configuration details depend on the protocol and profile used. These details are provided in a user's manual supplied with the FBA module.

Details for the ABB Drives profile (which apply for all protocols) are provided in section [ABB Drives profile technical data](#) on page 240.

Control interface

In general, the basic control interface between the fieldbus system and the drive consists of:

- Output Words:
 - CONTROL WORD
 - REFERENCE (speed or frequency)
 - Others: The drive supports a maximum of 15 output words. Protocols limits may further restrict the total.
- Input Words:
 - STATUS WORD
 - Actual Value (speed or frequency)
 - Others: The drive supports a maximum of 15 input words. Protocols limits may further restrict the total.

Note: The words “output” and “input” are used as seen from the fieldbus controller point of view. For example an output describes data flow from the fieldbus controller to the drive and appears as an input from the drive point of view.

The meanings of the controller interface words are not restricted by the ACQ550. However, the profile used may set particular meanings.

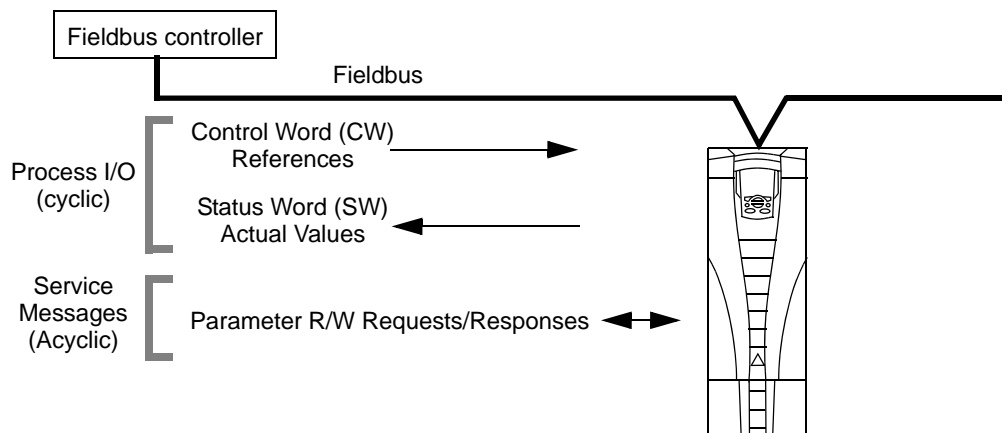

Control Word

The CONTROL WORD is the principal means for controlling the drive from a fieldbus system. The fieldbus controller sends the CONTROL WORD to the drive. The drive switches between states according to the bit-coded instructions in the CONTROL WORD. Using the CONTROL WORD requires that:

- The drive is in remote (Auto) control.

- The serial communication channel is defined as the source for controlling commands from EXT1 (set using parameters 1001 EXT1 COMMANDS and 1102 EXT1/EXT2 SEL).
- The external plug-in fieldbus adapter is activated:
 - Parameter 9802 COMM PROT SEL = 4 (EXT FBA).
 - The external plug-in fieldbus adapter is configured to use the drive profile mode or drive profile objects.

The content of the CONTROL WORD depends on the protocol/profile used. See the user's manual provided with the FBA module and/or section [ABB Drives profile technical data](#) on page 240.

Status Word

The STATUS WORD is a 16-bit word containing status information, sent by the drive to the fieldbus controller. The content of the STATUS WORD depends on the protocol/profile used. See the user's manual provided with the FBA module and/or section [ABB Drives profile technical data](#) on page 240.

Reference

The contents of each REFERENCE word:

- can be used, as speed or frequency reference
- is a 16-bit word comprised of a sign bit and a 15-bit integer
- Negative references (indicating reversed rotation direction) are indicated by the two's complement of the corresponding positive reference value.

The use of a second reference (REF2) is supported only when a protocol is configured for the ABB Drives profile.

Reference scaling is fieldbus type specific. See the user's manual provided with the FBA module and/or the following sections as appropriate:

- [Reference scaling](#) on page 244 ([ABB Drives profile technical data](#))
- [Reference scaling](#) on page 248 ([Generic profile technical data](#)).

Actual Values

Actual Values are 16-bit words containing information on selected operations of the drive. Drive Actual Values (for example, [Group 10: START/STOP/DIR](#) parameters) can be mapped to Input Words using [Group 51: EXT COMM MODULE](#) parameters (protocol-dependent, but typically parameters 5104...5126).

Planning

Network planning should address the following questions:

- What types and quantities of devices must be connected to the network?
- What control information must be sent down to the drives?
- What feedback information must be sent from the drives to the controlling system?

Mechanical and electrical installation – FBA



WARNING! Connections should be made only while the drive is disconnected from the power source.

Overview

The FBA (fieldbus adapter) is a plug-in module that fits in the drive's expansion slot 2. The module is held in place with plastic retaining clips and two screws. The screws also ground the shield for the module cable and connect the module GND signals to the drive control board.

On installation of the module, electrical connection to the drive is automatically established through the 34-pin connector.

Mounting procedure

Note: Install the input power and motor cables first.

1. Insert the module carefully into the drive expansion slot 2 until the retaining clips lock the module into position.
2. Fasten the two screws (included) to the stand-offs.

Note: Correct installation of the screws is essential for fulfilling the EMC requirements and for proper operation of the module.

3. Open the appropriate knockout in the conduit box and install the cable clamp for the network cable.
4. Route the network cable through the cable clamp.
5. Connect the network cable to the module's network connector.
6. Tighten the cable clamp.
7. Install the conduit box cover (1 screw).
8. For configuration information see the following:
 - section [Communication set-up – FBA](#) on page 233
 - section [Activate drive control functions – FBA](#) on page 233
 - The protocol specific documentation provided with the module.

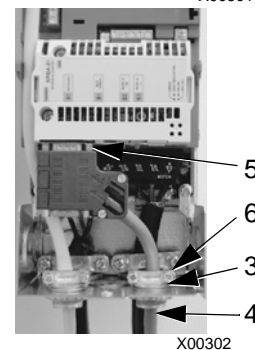
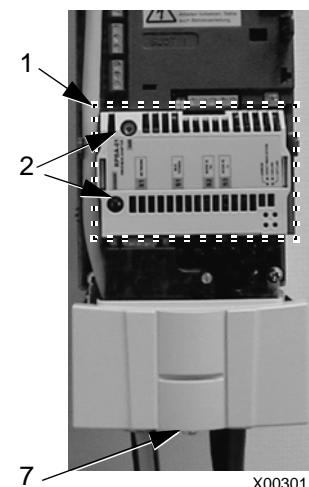

Communication set-up – FBA

Serial communication selection

To activate the serial communication, use parameter 9802 COMM PROT SEL. Set 9802 = 4 (EXT FBA).

Serial communication configuration

Setting 9802, together with mounting a particular FBA module, automatically sets the appropriate default values in parameters that define the communication process. These parameters and descriptions are defined in the user's manual supplied with the FBA module.

- Parameter 5101 is automatically configured.
- Parameters 5102...5126 are protocol-dependent and define, for example, the profile used and additional I/O words. These parameters are referred to as the fieldbus configuration parameters. See the user's manual provided with the FBA module for details on the fieldbus configuration parameters.
- Parameter 5127 forces the validation of changes to parameters 5102...5126. If parameter 5127 is not used, changes to parameters 5102...5126 take affect only after the drive power is cycled.
- Parameters 5128...5133 provide data about the FBA module currently installed (e.g. component versions and status).

See [Group 51: EXT COMM MODULE](#) for parameter descriptions.

Activate drive control functions – FBA

Fieldbus control of various drive functions requires configuration to:

- tell the drive to accept fieldbus control of the function
- define as a fieldbus input, any drive data required for control
- define as a fieldbus output, any control data required by the drive.

The following sections describe, at a general level, the configuration required for each control function. The last column in each table below is deliberately blank. See the user's manual supplied with the FBA module for the appropriate entry.

Start/Stop Direction control

Using the fieldbus for start/stop/direction control of the drive requires:

- drive parameter values set as defined below
- fieldbus controller supplied command(s) in the appropriate location. (The location is defined by the Protocol Reference, which is protocol dependent.)

Drive parameter		Value	Description	Protocol reference
1001	EXT1 COMMANDS	10 (COMM)	Start/Stop controlled by fieldbus with Ext1 selected.	

Drive parameter		Value	Description	Protocol reference
1002	EXT2 COMMANDS	10 (COMM)	Start/Stop by controlled fieldbus with Ext2 selected.	
1003	DIRECTION	3 (REQUEST)	Direction controlled by fieldbus.	

Input reference select

Using the fieldbus to provide input reference to the drive requires:

- drive parameter value set as defined below
- fieldbus controller supplied reference word(s) in the appropriate location. (The location is defined by the Protocol Reference, which is protocol dependent.)

Drive parameter		Value	Description	Protocol reference
1102	EXT1/EXT2 SEL	8 (COMM)	Ref. selected by fieldbus. (Required only if 2 references used.)	
1103	REF1 SELECT	8 (COMM) 9 (COMM+AI1) 10 (COMM*AI1)	Input reference 1 supplied by fieldbus.	
1106	REF2 SELECT	8 (COMM) 9 (COMM+AI) 10 (COMM*AI)	Input reference 2 supplied by fieldbus. (Required only if 2 references used.)	

Note: Multiple references are supported only when using the ABB Drives profile.

Scaling

Where required, REFERENCES can be scaled. See the following sections, as appropriate:

- [Reference scaling](#) on page 244 (*ABB Drives profile technical data*)
- [Reference scaling](#) on page 248 (*Generic profile technical data*).

System control

Using the fieldbus for miscellaneous drive control requires:

- drive parameter values set as defined below
- fieldbus controller command(s) in the appropriate location. (The location is defined by the Protocol Reference, which is protocol dependent.)

Drive parameter		Value	Description	Protocol reference
1601	RUN ENABLE	7 (COMM)	Run enable by fieldbus.	
1604	FAULT RESET SEL	8 (COMM)	Fault reset by fieldbus.	
1607	PARAM SAVE	1 (SAVE)	Saves altered parameters to memory (then value returns to 0).	

Relay output control

Using the fieldbus for relay output control requires:

- drive parameter values set as defined below
- fieldbus controller supplied, binary coded, relay command(s) in the appropriate location. (The location is defined by the Protocol Reference, which is protocol dependent.)

Drive parameter		Value	Description	Protocol reference
1401	RELAY OUTPUT 1	35 (COMM)	Relay Output 1 controlled by fieldbus.	
1402	RELAY OUTPUT 2	36 (COMM(-1))	Relay Output 2 controlled by fieldbus.	
1403	RELAY OUTPUT 3		Relay Output 3 controlled by fieldbus.	
1410 ¹	RELAY OUTPUT 4		Relay Output 4 controlled by fieldbus.	
1411 ¹	RELAY OUTPUT 5		Relay Output 5 controlled by fieldbus.	
1412 ¹	RELAY OUTPUT 6		Relay Output 6 controlled by fieldbus.	

¹ More than 3 relays requires the addition of a relay extension module.

Note: Relay status feedback occurs without configuration as defined below.

Drive parameter		Value	Protocol reference
0122	RO 1-3 STATUS	Relay 1...3 status.	
0123	RO 4-6 STATUS	Relay 4...6 status.	

Analog output control

Using the fieldbus for analog output control (e.g. PID setpoint) requires:

- drive parameter values set as defined below
- fieldbus controller supplied analog value(s) in the appropriate location. (The location is defined by the Protocol Reference, which is protocol dependent.)

Drive parameter		Value	Description	Protocol reference
1501	AO1 CONTENT SEL	135 (COMM VALUE 1)	Analog Output 1 controlled by writing to parameter 0135.	–
0135	COMM VALUE 1	–		
1502 ... 1505	AO1 CONTENT MIN ... MAXIMUM AO1	Set appropriate values.	Used for scaling	–
1506	FILTER AO1		Filter time constant for AO1.	–
1507	AO2 CONTENT SEL	136 (COMM VALUE 2)	Analog Output 2 controlled by writing to parameter 0136.	–
0136	COMM VALUE 2	–		
1508 ... 1511	AO2 CONTENT MIN ... MAXIMUM AO2	Set appropriate values.	Used for scaling	–
1512	FILTER AO2		Filter time constant for AO2.	–

PID Control setpoint source

Using the following settings to select the fieldbus as the setpoint source for PID loops:

Drive parameter		Value	Setting	Protocol reference
4010	SET POINT SEL (Set 1)	8 (COMM VALUE 1)	Setpoint is input reference 2 (+/-/* AI1)	
4110	SET POINT SEL (Set 2)	9 (COMM+AI1)		
4210	SET POINT SEL (Ext/Trim)	10 (COMM*AI1)		

Communication fault

When using fieldbus control, specify the drive's action if serial communication is lost.

Drive parameter		Value	Description
3018	COMM FAULT FUNC	0 (NOT SEL) 1 (FAULT) 2 (CONST SP7) 3 (LAST SPEED)	Set for appropriate drive response.
3019	COMM FAULT TIME	Set time delay before acting on a communication loss.	

Feedback from the drive – FBA

Inputs to the controller (drive outputs) have pre-defined meanings established by the protocol. This feedback does not require drive configuration. The following table lists a sample of feedback data. For a complete listing, see all parameters listed in section [Complete parameter descriptions](#) on page 83.

Drive parameter		Protocol reference
0102	SPEED	
0103	OUTPUT FREQ	
0104	CURRENT	
0105	TORQUE	
0106	POWER	
0107	DC BUS VOLTAGE	
0109	OUTPUT VOLTAGE	
0301	FB CMD WORD 1 – bit 0 (STOP)	
0301	FB CMD WORD 1 – bit 2 (REV)	
0118	DI 1-3 STATUS – bit 0 (DI3)	

Scaling

To scale the drive parameter values see the following sections, as appropriate:

- [Actual Value scaling](#) on page 247 (*ABB Drives profile technical data*)
- [Actual Value scaling](#) on page 249 (*Generic profile technical data*).

Diagnostics – FBA

Fault handling

The ACQ550 provides fault information as follows:

- The control panel display shows a fault code and text. See chapter [Diagnostics](#) on page [251](#) for a complete description.
- Parameters 0401 LAST FAULT, 0412 PREVIOUS FAULT1 and 0413 PREVIOUS FAULT2 store the most recent faults.
- For fieldbus access, the drive reports faults as a hexadecimal value, assigned and coded according to the DRIVECOM specification. See the table below. Not all profiles support requesting fault codes using this specification. For profiles that support this specification, the profile documentation defines the proper fault request process.

	Drive fault code	Fieldbus fault code (DRIVECOM specification)
1	OVERCURRENT	2310h
2	DC OVERVOLT	3210h
3	DEV OVERTEMP	4210h
4	SHORT CIRC	2340h
5	Reserved	FF6Bh
6	DC UNDERVOLT	3220h
7	AI1 LOSS	8110h
8	AI2 LOSS	8110h
9	MOT OVERTEMP	4310h
10	PANEL LOSS	5300h
11	ID RUN FAIL	FF84h
12	MOTOR STALL	7121h
14	EXT FAULT 1	9000h
15	EXT FAULT 2	9001h
16	EARTH FAULT	2330h
17	Obsolete	FF6Ah
18	THERM FAIL	5210h
19	OPEX LINK	7500h
20	OPEX PWR	5414h
21	CURR MEAS	2211h
22	SUPPLY PHASE	3130h
23	OBSOLETE	7301h
24	OVERSPEED	7310h
25	Reserved	FF80h
26	DRIVE ID	5400h

Drive fault code		Fieldbus fault code (DRIVECOM specification)
27	CONFIG FILE	630Fh
28	SERIAL 1 ERR	7510h
29	EFB CON FILE	6306h
30	FORCE TRIP	FF90h
31	EFB 1	FF92h
32	EFB 2	FF93h
33	EFB 3	FF94h
34	MOTOR PHASE	FF56h
35	OUTP WIRING	FF95h
36	INCOMPATIBLE SW	630Fh
37	CB OVERTEMP	4110h
38	USER LOAD CURVE	FF6Bh
101	SERF CORRUPT	FF55h
102	Reserved	FF55h
103	SERF MACRO	FF55h
104	Reserved	FF55h
105	Reserved	FF55h
201	DSP T1 OVERLOAD	6100h
202	DSP T2 OVERLOAD	6100h
203	DSP T3 OVERLOAD	6100h
204	DSP STACK ERROR	6100h
205	Reserved (obsolete)	5000h
206	CB ID ERROR	5000h
207	EFB LOAD ERROR	6100h
1000	PAR HZRPM	6320h
1001	PAR PFC REF NEG	6320h
1002	Reserved (obsolete)	6320h
1003	PAR AI SCALE	6320h
1004	PAR AO SCALE	6320h
1005	PAR PCU 2	6320h
1006	PAR EXT RO	6320h
1007	PAR FIELDBUS MISSING	6320h
1008	PAR PFC MODE	6320h
1009	PAR PCU 1	6320h
1012	PAR PFC IO 1	6320h
1013	PAR PFC IO 2	6320h
1014	PAR PFC IO 3	6320h
1016	PAR USER LOAD C	6320h

Serial communication diagnostics

Besides the drive fault codes, the FBA module has diagnostic tools. Refer to the user's manual supplied with the FBA module.

ABB Drives profile technical data

Overview

The ABB Drives profile provides a standard profile that can be used on multiple protocols, including protocols available on the FBA module. This section describes the ABB Drives profile implemented for FBA modules.

Control Word

As described earlier in section [Control interface](#) on page 230, the CONTROL WORD is the principal means for controlling the drive from a fieldbus system.

The following table and the state diagram later in this sub-section describe the CONTROL WORD content for the ABB Drives profile.

ABB Drives profile (FBA) CONTROL WORD				
Bit	Name	Value	Commanded state	Comments
0	OFF1 CONTROL	1	READY TO OPERATE	Enter READY TO OPERATE
		0	EMERGENCY OFF	Drive ramps to stop according to currently active deceleration ramp (2203 or 2205) Normal command sequence: <ul style="list-style-type: none"> • Enter OFF1 ACTIVE • Proceed to READY TO SWITCH ON, unless other interlocks (OFF2, OFF3) are active.
1	OFF2 CONTROL	1	OPERATING	Continue operation (OFF2 inactive)
		0	EMERGENCY OFF	Drive coasts to stop. Normal command sequence: <ul style="list-style-type: none"> • Enter OFF2 ACTIVE • Proceed to SWITCHON INHIBITED
2	OFF3 CONTROL	1	OPERATING	Continue operation (OFF3 inactive)
		0	EMERGENCY STOP	Drive stops within in time specified by parameter 2208. Normal command sequence: <ul style="list-style-type: none"> • Enter OFF3 ACTIVE • Proceed to SWITCH ON INHIBITED <div style="display: flex; align-items: center;">  <div style="margin-left: 5px;"> <p>WARNING! Be sure motor and driven equipment can be stopped using this mode.</p> </div> </div>
3	INHIBIT OPERATION	1	OPERATION ENABLED	Enter OPERATION ENABLED (Note the Run enable signal must be active. See 1601. If 1601 is set to COMM, this bit also activates the Run Enable signal.)
		0	OPERATION INHIBITED	Inhibit operation. Enter OPERATION INHIBITED
4	RAMP_OUT_ZERO	1	NORMAL OPERATION	Enter RAMP FUNCTION GENERATOR: ACCELERATION ENABLED
		0	RFG OUT ZERO	Force ramp function generator output to Zero. Drive ramps to stop (current and DC voltage limits in force).

ABB Drives profile (FBA) CONTROL WORD				
Bit	Name	Value	Commanded state	Comments
5	RAMP_HOLD	1	RFG OUT ENABLED	Enable ramp function. Enter RAMP FUNCTION GENERATOR: ACCELERATOR ENABLED
		0	RFG OUT HOLD	Halt ramping (Ramp Function Generator output held)
6	RAMP_IN_ZERO	1	RFG INPUT ENABLED	Normal operation. Enter OPERATING
		0	RFG INPUT ZERO	Force Ramp Function Generator input to zero.
7	RESET	0=>1	RESET	Fault reset if an active fault exists (Enter SWITCH-ON INHIBITED). Effective if 1604 = COMM.
		0	OPERATING	Continue normal operation
8...9	Unused			
10	REMOTE_CMD	1		Fieldbus control enabled
		0		<ul style="list-style-type: none"> • CW ≠ 0 or Ref ≠ 0: Retain last CW and Ref. • CW = 0 and Ref = 0: Fieldbus control enabled. • Ref and deceleration/acceleration ramp are locked.
11	EXT CTRL LOC	1	EXT2 SELECT	Select external control location 2 (EXT2). Effective if 1102 = COMM.
		0	EXT1 SELECT	Select external control location 1 (EXT1). Effective if 1102 = COMM.
12...15	Unused			

Status Word

As described earlier in section [Control interface](#) on page 230, the contents of the STATUS WORD is status information, sent by the drive to the master station. The following table and the state diagram later in this sub-section describe the status word content.

ABB Drives profile (FBA) STATUS WORD			
Bit	Name	Value	Description (Correspond to states/boxes in the state diagram)
0	RDY_ON	1	READY TO SWITCH ON
		0	NOT READY TO SWITCH ON
1	RDY_RUN	1	READY TO OPERATE
		0	OFF1 ACTIVE
2	RDY_REF	1	OPERATION ENABLED
		0	OPERATION INHIBITED
3	TRIPPED	0...1	FAULT
		0	No fault

ABB Drives profile (FBA) STATUS WORD			
Bit	Name	Value	Description (Correspond to states/boxes in the state diagram)
4	OFF_2_STA	1	OFF2 inactive
		0	OFF2 ACTIVE
5	OFF_3_STA	1	OFF3 inactive
		0	OFF3 ACTIVE
6	SWC_ON_INHIB	1	SWITCH-ON INHIBIT ACTIVE
		0	SWITCH-ON INHIBIT NOT ACTIVE
7	ALARM	1	Alarm (See section Alarm listing on page 258 for details on alarms.)
		0	No alarm
8	AT_SETPOINT	1	OPERATING. Actual value equals (within tolerance limits) the reference value.
		0	Actual value is outside tolerance limits (not equal to reference value).
9	REMOTE	1	Drive control location: REMOTE (EXT1 or EXT2)
		0	Drive control location: LOCAL
10	ABOVE_LIMIT	1	Supervised parameter's value \geq supervision high limit. Bit remains "1" until supervised parameter's value < supervision low limit. See Group 32: SUPERVISION .
		0	Supervised parameter's value < supervision low limit. Bit remains "0" until supervised parameter's value > supervision high limit. See Group 32: SUPERVISION .
11	EXT CTRL LOC	1	External control location 2 (EXT2) selected
		0	External control location 1 (EXT1) selected
12	EXT RUN ENABLE	1	External Run Enable signal received
		0	No External Run Enable signal received
13... 15	Unused		

The state diagram below describes the start-stop function of CONTROL WORD (CW) and STATUS WORD (SW) bits.

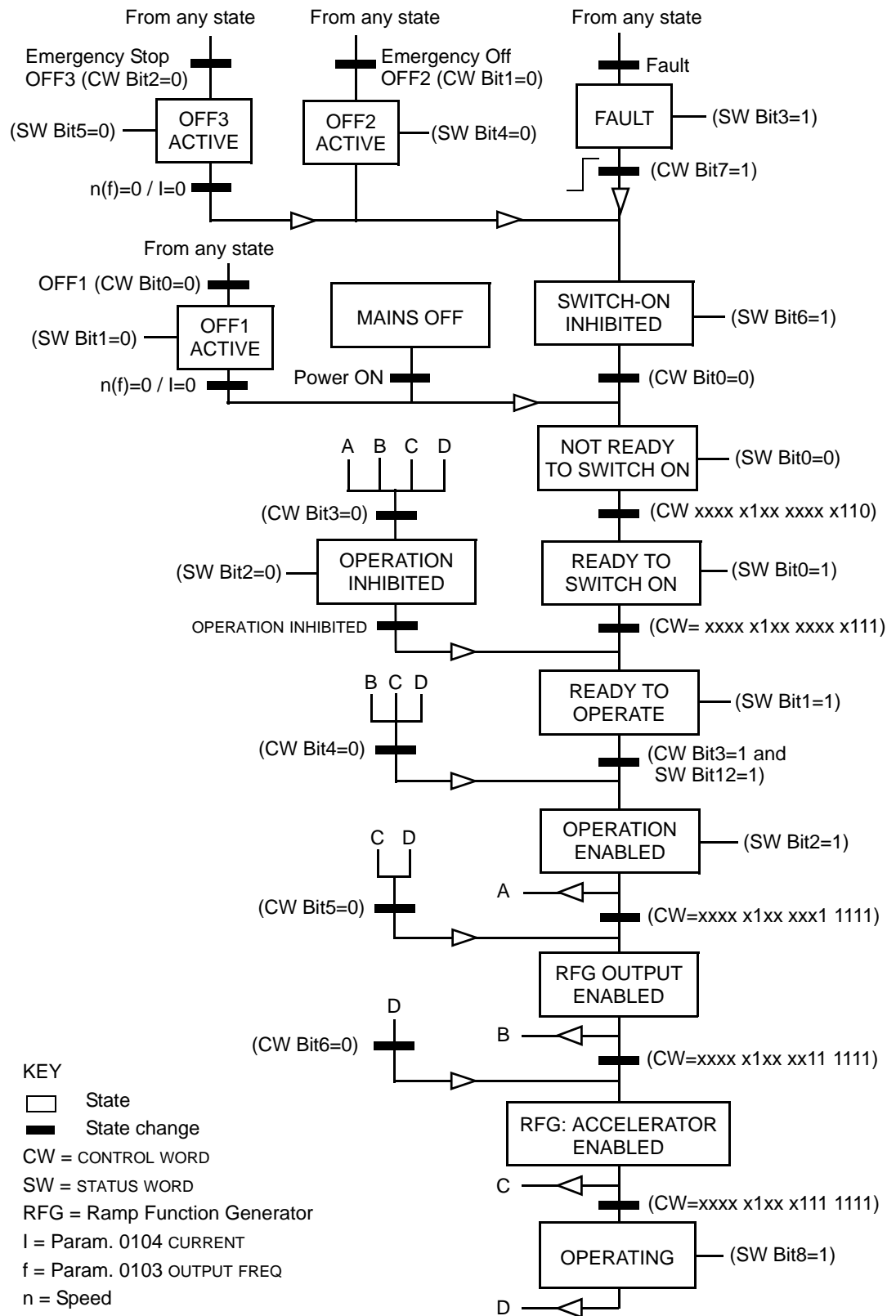

Reference

As described earlier in section [Control interface](#) on page 230, the REFERENCE word is a speed or frequency reference.

Reference scaling

The following table describes REFERENCE scaling for the ABB Drives profile.

ABB Drives Profile (FBA)				
Reference	Range	Reference type	Scaling	Remarks
REF1	-32767... +32767	Speed or frequency	-20000 = -(par. 1105) 0 = 0 +20000 = (par. 1105) (20000 corresponds to 100%)	Final reference limited by 1104/1105. Actual motor speed limited by 2001/2002 (speed) or 2007/2008 (frequency).
REF2	-32767... +32767	Speed or frequency	-10000 = -(par. 1108) 0 = 0 +10000 = (par. 1108) (10000 corresponds to 100%)	Final reference limited by 1107/1108. Actual motor speed limited by 2001/2002 (speed) or 2007/2008 (frequency).
		Torque	-10000 = -(par. 1108) 0 = 0 +10000 = (par. 1108) (10000 corresponds to 100%)	Final reference limited by 2015/2017 (torque1) or 2016/2018 (torque2).
		PID Reference	-10000 = -(par. 1108) 0 = 0 +10000 = (par. 1108) (10000 corresponds to 100%)	Final reference limited by 4012/4013 (PID set1) or 4112/4113 (PID set2).

Note: The setting of parameter 1104 REF1 MIN and 1107 REF2 MIN has no effect on the scaling of references.

When parameter 1103 REF1 SELECT or 1106 REF2 SELECT is set to COMM+AI1 or COMM*AI1, the reference is scaled as follows:

ABB Drives profile (FBA)		
Reference	Value setting	AI reference scaling
REF1	COMM+AI1	$\text{COMM (\%)} + (\text{AI (\%)} - 0.5 \cdot \text{REF1 MAX (\%)})$ <p style="text-align: center;">Fieldbus reference correction coefficient</p> <p style="text-align: center;">(100 + 0.5 · (Par. 1105))%</p> <p style="text-align: center;">100%</p> <p style="text-align: center;">(100 - 0.5 · (par. 1105))%</p> <p style="text-align: center;">0% 50% 100%</p>

ABB Drives profile (FBA)		
Reference	Value setting	AI reference scaling
REF1	COMM+AI1	$\text{COMM (\%)} \cdot (\text{AI (\%)} / 0.5 \cdot \text{REF1 MAX (\%)})$ <p>The graph for REF1 shows a linear relationship. The x-axis is labeled 'AI1 input signal' and ranges from 0% to 100% with a tick at 50%. The y-axis is labeled 'Fieldbus reference correction coefficient' and ranges from 0% to 200% with a tick at 100%. A solid line starts at the point $(0, (100 - 0.5 \cdot (\text{par. 1105}))\%)$ and ends at $(100, 200\%)$. Dashed lines indicate the 100% mark on both axes.</p>
REF2	COMM+AI1	$\text{COMM (\%)} + (\text{AI (\%)} - 0.5 \cdot \text{REF2 MAX (\%)})$ <p>The graph for REF2 shows a linear relationship. The x-axis is labeled 'AI1 input signal' and ranges from 0% to 100% with a tick at 50%. The y-axis is labeled 'Fieldbus reference correction coefficient' and ranges from 0% to 200% with a tick at 100%. A solid line starts at the point $(0, (100 - 0.5 \cdot (\text{par. 1108}))\%)$ and ends at $(100, (100 + 0.5 \cdot (\text{Par. 1108}))\%)$. Dashed lines indicate the 100% mark on both axes.</p>
REF2	COMM*AI1	$\text{COMM (\%)} \cdot (\text{AI (\%)} / 0.5 \cdot \text{REF2 MAX (\%)})$ <p>The graph for REF2 shows a linear relationship. The x-axis is labeled 'AI1 input signal' and ranges from 0% to 100% with a tick at 50%. The y-axis is labeled 'Fieldbus reference correction coefficient' and ranges from 0% to 200% with a tick at 100%. A solid line starts at the origin $(0, 0\%)$ and ends at $(100, 200\%)$. Dashed lines indicate the 100% mark on both axes.</p>

Reference handling

Use [Group 10: START/STOP/DIR](#) parameters to configure for control of rotation direction for each control location (EXT1 and EXT2). The following diagrams illustrate how group 10 parameters and the sign of the fieldbus reference interact to produce REFERENCE values (REF1 and REF2). Note, fieldbus references are bipolar, that is they can be positive or negative.

ABB Drives profile		
Parameter	Value setting	AI reference scaling
1003 DIRECTION	1 (FORWARD)	<p>Max. ref. -----</p> <p>Resultant ref.</p> <p>Fieldbus reference</p> <p>-163% -100% 100% 163%</p> <p>-(Max. ref.) -----</p>
1003 DIRECTION	2 (REVERSE)	<p>Max. ref. -----</p> <p>Resultant ref.</p> <p>Fieldbus reference</p> <p>-163% -100% 100% 163%</p> <p>-(Max. ref.) -----</p>
1003 DIRECTION	3 (REQUEST)	<p>Max. ref. -----</p> <p>Resultant ref.</p> <p>Fieldbus reference</p> <p>-163% -100% 100% 163%</p> <p>-(Max. ref.) -----</p>

Actual Value

As described earlier in section [Control interface](#) on page 230, Actual Values are words containing drive values.

Actual Value scaling

The scaling of the integers sent to the fieldbus as Actual Values depends on the resolution of the selected drive parameter. Except as noted for ACT1 and ACT2 below, scale the feedback integer using the resolution listed for the parameter in section [Complete parameter list](#) on page 69. For example:

Feedback integer	Parameter resolution	Scaled Value
1	0.1 mA	$1 \cdot 0.1 \text{ mA} = 0.1 \text{ mA}$
10	0.1%	$10 \cdot 0.1\% = 1\%$

Data words 5 and 6 are scaled as follows:

ABB Drives profile		
	Contents	Scaling
ACT1	ACTUAL SPEED	$-20000 \dots +20000 = -(\text{par. 1105}) \dots +(\text{par. 1105})$
ACT2	TORQUE	$-10000 \dots +10000 = -100\% \dots +100\%$

Virtual addresses of the drive control

The virtual address area of the drive control is allocated as follows:

1	Control Word
2	Reference 1 (REF1)
3	Reference 2 (REF2)
4	Status Word
5	Actual Value 1 (ACT1)
6	Actual Value 2 (ACT2)

Generic profile technical data

Overview

The generic profile aims to fulfill the industry-standard drive profile for each protocol (e.g. PROFIdrive for PROFIBUS, AC/DC Drive for DeviceNet).

Control Word

As described earlier in section [Control interface](#) on page 230, the CONTROL WORD is the principal means for controlling the drive from a fieldbus system. For specific CONTROL WORD content, see the user's manual provided with the FBA module.

Status Word

As described earlier in section [Control interface](#) on page 230, the contents of the STATUS WORD is status information, sent by the drive to the master station. For specific STATUS WORD content, see the user's manual provided with the FBA module.

Reference

As described earlier in section [Control interface](#) on page 230, the REFERENCE word is a speed or frequency reference.

Note: REF2 is not supported by the Generic Drive profiles.

Reference scaling

REFERENCE scaling is fieldbus type specific. However, at the drive, the meaning of a 100% REFERENCE value is fixed as described in the table below. For a detailed description on the range and scaling of the REFERENCE, see the user's manual supplied with the FBA module.

Generic profile				
Reference	Range	Reference type	Scaling	Remarks
REF	Fieldbus specific	Speed	-100% = -(par. 9908) 0 = 0 +100 = (par. 9908)	Final reference limited by 1104/1105. Actual motor speed limited by 2001/2002 (speed).
		Frequency	-100% = -(par. 9907) 0 = 0 +100 = (par. 9907)	Final reference limited by 1104/1105. Actual motor speed limited by 2007/2008 (frequency).

Actual Values

As described earlier in section [Control interface](#) on page 230, Actual Values are words containing drive values.

Actual Value scaling

For Actual Values, scale the feedback integer using the parameter's resolution. (See section [Complete parameter list](#) on page 69 for parameter resolutions.) For example:

Feedback integer	Parameter resolution	(Feedback integer) · (Parameter resolution) = Scaled Value
1	0.1 mA	1 · 0.1 mA = 0.1 mA
10	0.1%	10 · 0.1% = 1%

Where parameters are in percent, the [Complete parameter list](#) section specifies what parameter corresponds to 100%. In such cases, to convert from percent to engineering units, multiply by the value of the parameter that defines 100% and divide by 100%. For example:

Feedback integer	Parameter resolution	Value of the parameter that defines 100%	(Feedback integer) · (Parameter resolution) · (Value of 100% ref.) / 100% = Scaled Value
10	0.1%	1500 rpm ¹	10 · 0.1% · 1500 RPM / 100% = 15 rpm
100	0.1%	500 Hz ²	100 · 0.1% · 500 Hz / 100% = 50 Hz

¹ Assuming, for the sake of this example, that the Actual Value uses parameter 9908 MOT NOM SPEED as the 100% reference and that 9908 = 1500 rpm.

² Assuming, for the sake of this example, that the Actual Value uses parameter 9907 MOT NOM FREQ as the 100% reference and that 9907 = 500 Hz.

Actual Value mapping

See the user's manual supplied with the FBA module.

Diagnostics



WARNING! Do not attempt any measurement, parts replacement or other service procedure not described in this manual. Such action will void the warranty, may endanger correct operation and increase downtime and expense.



WARNING! All electrical installation and maintenance work described in this chapter should only be undertaken by qualified service personnel. The safety instructions in chapter [Safety](#) on page [5](#) must be followed.

Diagnostic displays

The drive detects error situations and reports them using:

- the green and red LED on the body of the drive
- the status LED on the control panel (if an ACQ Control Panel is attached to the drive)
- the control panel display (if a control panel is attached to the drive)
- the Fault Word and Alarm Word parameter bits (parameters 0305 to 0309). See [Group 03: FB ACTUAL SIGNALS](#) on page [89](#) for the bit definitions.

The form of the display depends on the severity of the error. You can specify the severity for many errors by directing the drive to:

- ignore the error situation
- report the situation as an alarm
- report the situation as a fault.

Red – Faults

The drive signals that it has detected a severe error, or fault, by:

- enabling the red LED on the drive (LED is either steady on or blinking)
- showing the steady red status LED on the control panel (if attached to the drive)
- setting an appropriate bit in a Fault Word parameter (0305 to 0307)
- overriding the control panel display with the display of a fault code in the Fault mode
- stopping the motor (if it was on).

The fault code on the control panel display is temporary. Pressing any of the following keys removes the fault message: MENU, ENTER, UP, or DOWN key. The message reappears after a few seconds if the control panel is not touched and the fault is still active.

Flashing green – Alarms

For less severe errors, called alarms, the diagnostic display is advisory. For these situations, the drive is simply reporting that it had detected something “unusual.” In these situations, the drive:

- flashes the green LED on the drive (does not apply to alarms that arise from control panel operation errors)
- flashes the green LED on the control panel (if attached to the drive)
- sets an appropriate bit in an Alarm Word parameter (0308 or 0309). See [Group 03: FB ACTUAL SIGNALS](#) on page 89 for the bit definitions
- overrides the control panel display with the display of an alarm code and/or name in the Fault mode.

Alarm messages disappear from the control panel display after a few seconds. The message returns periodically as long as the alarm condition exists.

Correcting faults

The recommended corrective action for faults is:

- Use the table in section [Fault listing](#) below to find and address the root cause of the problem.
- Reset the drive. See section [Fault resetting](#) on page 257.

Fault listing

The following table lists the faults by code number and describes each. The fault name is the long form shown in the Fault mode of the ACQ Control Panel when the fault occurs. The fault names shown (for ACQ Control Panel only) in the Fault Logger mode (see page 49) and the fault names for parameter 0401 LAST FAULT may be shorter.

Fault code	Fault name in panel	Description and recommended corrective action
1	OVERCURRENT	Output current is excessive. Check for and correct: <ul style="list-style-type: none"> • Excessive motor load. • Insufficient acceleration time (parameters 2202 ACCELER TIME 1 and 2205 ACCELER TIME 2). • Faulty motor, motor cables or connections.
2	DC OVERVOLT	Intermediate circuit DC voltage is excessive. Check for and correct: <ul style="list-style-type: none"> • Static or transient overvoltages in the input power supply. • Insufficient deceleration time (parameters 2203 DECELER TIME 1 and 2206 DECELER TIME 2). • Undersized brake chopper (if present). • Verify that overvoltage controller is ON (using parameter 2005).

Fault code	Fault name in panel	Description and recommended corrective action
3	DEV OVERTEMP	Drive heatsink is overheated. Temperature is at or above limit. R1...R4: 115 °C (239 °F) R5, R6: 125 °C (257 °F) Check for and correct: <ul style="list-style-type: none"> • Fan failure. • Obstructions in the air flow. • Dirt or dust coating on the heat sink. • Excessive ambient temperature. • Excessive motor load.
4	SHORT CIRC	Fault current. Check for and correct: <ul style="list-style-type: none"> • A short-circuit in the motor cable(s) or motor. • Supply disturbances.
5	RESERVED	Not used.
6	DC UNDERVOLT	Intermediate circuit DC voltage is not sufficient. Check for and correct: <ul style="list-style-type: none"> • Missing phase in the input power supply. • Blown fuse. • Undervoltage on mains.
7	AI1 LOSS	Analog input 1 loss. Analog input value is less than AI1 FAULT LIMIT (3021). Check for and correct: <ul style="list-style-type: none"> • Source and connection for analog input. • Parameter settings for AI1 FAULT LIMIT (3021) and 3001 AI<MIN FUNCTION.
8	AI2 LOSS	Analog input 2 loss. Analog input value is less than AI2 FAULT LIMIT (3022). Check for and correct: <ul style="list-style-type: none"> • Source and connection for analog input. • Parameter settings for AI2 FAULT LIMIT (3022) and 3001 AI<MIN FUNCTION.
9	MOT OVERTEMP	Motor is too hot, based on either the drive's estimate or on temperature feedback. <ul style="list-style-type: none"> • Check for overloaded motor. • Adjust the parameters used for the estimate (3005...3009). • Check the temperature sensors and Group 35: MOTOR TEMP MEAS parameters.
10	PANEL LOSS	Panel communication is lost and either: <ul style="list-style-type: none"> • Drive is in local control mode (the control panel displays LOC or OFF), or • Drive is in remote control mode (AUTO) and is parameterized to accept start/stop, direction or reference from the control panel. To correct check: <ul style="list-style-type: none"> • Communication lines and connections. • Parameter 3002 PANEL COMM ERR. • Parameters in Group 10: START/STOP/DIR and Group 11: REFERENCE SELECT (if drive operation is AUTO).
11	ID RUN FAIL	The Motor ID Run was not completed successfully. Check for and correct: <ul style="list-style-type: none"> • Motor connections. • Motor parameters 9905...9909.

Fault code	Fault name in panel	Description and recommended corrective action
12	MOTOR STALL	Motor or process stall. Motor is operating in the stall region. Check for and correct: <ul style="list-style-type: none"> Excessive load. Insufficient motor power. Parameters 3010...3012.
13	RESERVED	Not used.
14	EXT FAULT 1	Digital input defined to report first external fault is active. See parameter 3003 EXTERNAL FAULT 1.
15	EXT FAULT 2	Digital input defined to report second external fault is active. See parameter 3004 EXTERNAL FAULT 2.
16	EARTH FAULT	Possible ground fault detected in the motor or motor cables. The drive monitors for ground faults while the drive is running and while the drive is not running. Detection is more sensitive when the drive is not running and can produce false positives. Possible corrections: <ul style="list-style-type: none"> Check for/correct faults in the input wiring. Verify that motor cable does not exceed maximum specified length. A delta grounded input power supply and motor cables with high capacitance may result in erroneous error reports during non-running tests. To disable response to fault monitoring when the drive is not running, use parameter 3023 WIRING FAULT. To disable response to all ground fault monitoring, use parameter 3017 EARTH FAULT. Note: Disabling earth fault (ground fault) may void the warranty.
17	OBSOLETE	Not used.
18	THERM FAIL	Internal fault. The thermistor measuring the internal temperature of the drive is open or shorted. Contact your local ABB representative.
19	OPEX LINK	Internal fault. A communication-related problem has been detected on the fiber optic link between the control and OINT boards. Contact your local ABB representative.
20	OPEX PWR	Internal fault. Exceptionally low voltage detected on the OINT power supply. Contact your local ABB representative.
21	CURR MEAS	Internal fault. Current measurement is out of range. Contact your local ABB representative.
22	SUPPLY PHASE	Ripple voltage in the DC link is too high. Check for and correct: <ul style="list-style-type: none"> Missing mains phase. Blown fuse.
23	OBSOLETE	
24	OVERSPEED	Motor speed is greater than 120% of the larger (in magnitude) of 2001 MINIMUM SPEED or 2002 MAXIMUM SPEED. Check for and correct: <ul style="list-style-type: none"> Parameter settings for 2001 and 2002. Adequacy of motor braking torque. Applicability of torque control. Brake chopper and resistor.
25	RESERVED	Not used.
26	DRIVE ID	Internal fault. Configuration Block Drive ID is not valid. Contact your local ABB representative.
27	CONFIG FILE	Internal configuration file has an error. Contact your local ABB representative.

Fault code	Fault name in panel	Description and recommended corrective action
28	SERIAL 1 ERR	Fieldbus communication has timed out. Check for and correct: <ul style="list-style-type: none"> • Fault setup (3018 COMM FAULT FUNC and 3019 COMM FAULT TIME). • Communication settings (Group 51: EXT COMM MODULE or Group 53: EFB PROTOCOL as appropriate). • Poor connections and/or noise on line.
29	EFB CON FILE	Error in reading the configuration file for the embedded fieldbus.
30	FORCE TRIP	Fault trip forced by the fieldbus. See the fieldbus User's Manual.
31	EFB 1	Fault code reserved for the embedded fieldbus (EFB) protocol application. The meaning is protocol dependent.
32	EFB 2	
33	EFB 3	
34	MOTOR PHASE	
35	OUTP WIRING	Possible power wiring error detected. When the drive is not running it monitors for an improper connection between the drive input power and the drive output. Check for and correct: <ul style="list-style-type: none"> • Proper input wiring – line voltage is NOT connected to drive output. • The fault can be erroneously declared if the input power is a delta grounded system and motor cable capacitance is large. This fault can be disabled using parameter 3023 WIRING FAULT.
36	INCOMPATIBLE SW	The drive cannot use the software. <ul style="list-style-type: none"> • Internal fault. • The loaded software is not compatible with the drive. • Call support representative.
37	CB OVERTEMP	Drive control board is overheated. The fault trip limit is 88 °C. Check for and correct: <ul style="list-style-type: none"> • Excessive ambient temperature. • Fan failure. • Obstructions in the air flow.
38	USER LOAD CURVE	Condition defined by parameter 3701 USER LOAD C MODE has been valid longer than the time defined by 3703 USER LOAD C TIME.
101... 199	SYSTEM ERROR	Error internal to the drive. Contact your local ABB representative and report the error number.
201... 299	SYSTEM ERROR	Error in the system. Contact your local ABB representative and report the error number.
-	UNKNOWN DRIVE TYPE: ACQ550 SUPPORTED DRIVES: X	Wrong type of panel, i.e. panel that supports drive X but not the ACQ550, has been connected to the ACQ550.

Faults that indicate conflicts in the parameter settings are listed below.

Fault code	Fault name in panel	Description and recommended corrective action
1000	PAR HZRPM	Parameter values are inconsistent. Check for any of the following: <ul style="list-style-type: none"> • 2001 MINIMUM SPEED > 2002 MAXIMUM SPEED. • 2007 MINIMUM FREQ > 2008 MAXIMUM FREQ. • 2001 MINIMUM SPEED / 9908 MOTOR NOM SPEED is outside proper range (> 50). • 2002 MAXIMUM SPEED / 9908 MOTOR NOM SPEED is outside proper range (> 50). • 2007 MINIMUM FREQ / 9907 MOTOR NOM FREQ is outside proper range (> 50). • 2008 MAXIMUM FREQ / 9907 MOTOR NOM FREQ is outside proper range (> 50).
1001	PAR PFC REF NEG	Parameter values are inconsistent. Check for the following: <ul style="list-style-type: none"> • 2007 MINIMUM FREQ is negative, when 8123 PFC ENABLE is active.
1002	RESERVED	Not used.
1003	PAR AI SCALE	Parameter values are inconsistent. Check for any of the following: <ul style="list-style-type: none"> • 1301 MINIMUM AI1 > 1302 MAXIMUM AI1. • 1304 MINIMUM AI2 > 1305 MAXIMUM AI2.
1004	PAR AO SCALE	Parameter values are inconsistent. Check for any of the following: <ul style="list-style-type: none"> • 1504 MINIMUM AO1 > 1505 MAXIMUM AO1. • 1510 MINIMUM AO2 > 1511 MAXIMUM AO2.
1005	PAR PCU 2	Parameter values for power control are inconsistent: Improper motor nominal kVA or motor nominal power. Check for the following: <ul style="list-style-type: none"> • $1.1 \leq (9906 \text{ MOTOR NOM CURR} \cdot 9905 \text{ MOTOR NOM VOLT} \cdot 1.73 / P_N) \leq 3.0$ where: $P_N = 1000 \cdot 9909 \text{ MOTOR NOM POWER}$ (if units are kW) or $P_N = 746 \cdot 9909 \text{ MOTOR NOM POWER}$ (if units are hp, e.g. in US)
1006	PAR EXT RO	Parameter values are inconsistent. Check for the following: <ul style="list-style-type: none"> • Extension relay module not connected and • 1410...1412 RELAY OUTPUTS 4...6 have non-zero values.
1007	PAR FIELDBUS MISSING	Parameter values are inconsistent. Check for and correct: <ul style="list-style-type: none"> • A parameter is set for fieldbus control (e.g. 1001 EXT1 COMMANDS = 10 (COMM)), but 9802 COMM PROT SEL = 0.
1008	PAR PFC MODE	Parameter values are inconsistent – 9904 MOTOR CTRL MODE must be = 3 (SCALAR:FREQ), when 8123 PFC ENABLE is activated.
1009	PAR PCU 1	Parameter values for power control are inconsistent: Improper motor nominal frequency or speed. Check for both of the following: <ul style="list-style-type: none"> • $1 \leq (60 \cdot 9907 \text{ MOTOR NOM FREQ} / 9908 \text{ MOTOR NOM SPEED}) \leq 16$ • $0.8 \leq 9908 \text{ MOTOR NOM SPEED} / (120 \cdot 9907 \text{ MOTOR NOM FREQ} / \text{Motor Poles}) \leq 0.992$
1010/ 1011	RESERVED	Not used.
1012	PAR PFC IO 1	IO configuration is not complete – not enough relays are parameterized to PFC. Or, a conflict exists between Group 14: RELAY OUTPUTS , parameter 8117 NR OF AUX MOT and parameter 8118 AUTOCHNG INTERV.
1013	PAR PFC IO 2	IO configuration is not complete – the actual number of PFC motors (parameter 8127, MOTORS) does not match the PFC motors in Group 14: RELAY OUTPUTS and parameter 8118 AUTOCHNG INTERV.

Fault code	Fault name in panel	Description and recommended corrective action
1014	PAR PFC IO 3	IO configuration is not complete – the drive is unable to allocate a digital input (interlock) for each PFC motor (parameters 8120 INTERLOCKS and 8127 MOTORS).
1015	RESERVED	Not used.
1016	PAR USER LOAD C	Parameter values for the user load curve are inconsistent. Check that the following conditions are met: <ul style="list-style-type: none"> • 3704 LOAD FREQ 1 \leq 3707 LOAD FREQ 2 \leq 3710 LOAD FREQ 3 \leq 3713 LOAD FREQ 4 \leq 3716 LOAD FREQ 5. • 3705 LOAD TORQ LOW 1 \leq 3706 LOAD TORQ HIGH 1. • 3708 LOAD TORQ LOW 2 \leq 3709 LOAD TORQ HIGH 2. • 3711 LOAD TORQ LOW 3 \leq 3712 LOAD TORQ HIGH 3. • 3714 LOAD TORQ LOW 4 \leq 3715 LOAD TORQ HIGH 4. • 3717 LOAD TORQ LOW 5 \leq 3718 LOAD TORQ HIGH 5.

Fault resetting

The ACQ550 can be configured to automatically reset certain faults. Refer to parameter [Group 31: AUTOMATIC RESET](#).



WARNING! If an external source for start command is selected and it is active, the ACQ550 may start immediately after fault reset.

Flashing red LED

To reset the drive for faults indicated by a flashing red LED:

- Turn the power off for 5 minutes.

Red LED

To reset the drive for faults indicated by a red LED (on, not flashing), correct the problem and do one of the following:

- Press RESET from the control panel.
- Turn the power off for 5 minutes.

Depending on the value of 1604 FAULT RESET SEL, the following could also be used to reset the drive:

- digital input
- serial communication.

When the fault has been corrected, the motor can be started.

History

For reference, the last three fault codes are stored into parameters 0401, 0412, 0413. For the most recent fault (identified by parameter 0401), the drive stores additional data (in parameters 0402...0411) to aid in troubleshooting a problem. For example, parameter 0404 stores the motor speed at the time of the fault.

The ACQ Control Panel provides additional information about the fault history. See section [Fault History Mode](#) on page 49 for more information.

To clear the fault history (all of the [Group 04: FAULT HISTORY](#) parameters):

1. Using the control panel in the Parameters mode, select parameter 0401.
2. Press EDIT.
3. Press UP and DOWN at the same time.
4. Press SAVE.

Correcting alarms

The recommended corrective action for alarms is:

- Determine if the alarm requires any corrective action (action is not always required).
- Use the table in section [Alarm listing](#) below to find and address the root cause of the problem.

Alarm listing

The following table lists the alarms by code number and describes each.

Alarm code	Display	Description
2001	OVERCURRENT	Current limiting controller is active. Check for and correct: <ul style="list-style-type: none"> • Excessive motor load. • Insufficient acceleration time (parameters 2202 ACCELER TIME 1 and 2205 ACCELER TIME 2). • Faulty motor, motor cables or connections.
2002	OVERVOLTAGE	Overvoltage controller is active. Check for and correct: <ul style="list-style-type: none"> • Static or transient overvoltages in the input power supply. • Insufficient deceleration time (parameters 2203 DECELER TIME 1 and 2206 DECELER TIME 2).
2003	UNDERVOLTAGE	Undervoltage controller is active. Check for and correct: <ul style="list-style-type: none"> • Undervoltage on mains.
2004	DIR LOCK	The change in direction being attempted is not allowed. Either: <ul style="list-style-type: none"> • Do not attempt to change the direction of motor rotation, or • Change parameter 1003 DIRECTION to allow direction change (if reverse operation is safe).
2005	IO COMM	Fieldbus communication has timed out. Check for and correct: <ul style="list-style-type: none"> • Fault setup (3018 COMM FAULT FUNC and 3019 COMM FAULT TIME). • Communication settings (Group 51: EXT COMM MODULE or Group 53: EFB PROTOCOL as appropriate). • Poor connections and/or noise on line.
2006	AI1 LOSS	Analog input 1 is lost, or value is less than the minimum setting. Check: <ul style="list-style-type: none"> • Input source and connections. • Parameter that sets the minimum (3021). • Parameter that sets the alarm/fault operation (3001),

Alarm code	Display	Description
2007	AI2 LOSS	Analog input 2 is lost, or value is less than the minimum setting. Check: <ul style="list-style-type: none"> • Input source and connections. • Parameter that sets the minimum (3022). • Parameter that sets the alarm/fault operation (3001).
2008	PANEL LOSS	Panel communication is lost and either: <ul style="list-style-type: none"> • Drive is in local control mode (the control panel displays LOC), or • Drive is in remote control mode (AUTO) and is parameterized to accept start/stop, direction or reference from the control panel. To correct check: <ul style="list-style-type: none"> • Communication lines and connections. • Parameter 3002 PANEL COMM ERR. • Parameters in Group 10: START/STOP/DIR and Group 11: REFERENCE SELECT (if drive operation is REM).
2009	DEVICE OVERTEMP	Drive heatsink is hot. This alarm warns that a DEVICE OVERTEMP fault may be near. R1...R4: 100 °C (212 °F) R5, R6: 110 °C (230 °F) Check for and correct: <ul style="list-style-type: none"> • Fan failure. • Obstructions in the air flow. • Dirt or dust coating on the heat sink. • Excessive ambient temperature. • Excessive motor load.
2010	MOTOR TEMP	Motor is hot, based on either the drive's estimate or on temperature feedback. This alarm warns that a MOT OVERTEMP fault trip may be near. Check: <ul style="list-style-type: none"> • Check for overloaded motor. • Adjust the parameters used for the estimate (3005...3009). • Check the temperature sensors and Group 35: MOTOR TEMP MEAS.
2011	RESERVED	Not used.
2012	MOTOR STALL	Motor is operating in the stall region. This alarm warns that a MOTOR STALL fault trip may be near.
2013 (Note 1)	AUTORESET	This alarm warns that the drive is about to perform an automatic fault reset, which may start the motor. <ul style="list-style-type: none"> • To control automatic reset, use Group 31: AUTOMATIC RESET.
2014 (Note 1)	AUTOCHANGE	This alarm warns that the PFC autochange function is active. <ul style="list-style-type: none"> • To control PFC, use Group 81: PFC CONTROL and the PFC macro on page 64.
2015	PFC I LOCK	This alarm warns that the PFC interlocks are active, which means that the drive cannot start the following: <ul style="list-style-type: none"> • Any motor (when Autochange is used). • The speed regulated motor (when Autochange is not used).
2016/2017	RESERVED	Not used.

Alarm code	Display	Description
2018 (Note 1)	PID SLEEP	This alarm warns that the PID sleep function is active, which means that the motor could accelerate when the PID sleep function ends. <ul style="list-style-type: none"> To control PID sleep, use parameters 4022...4026 or 4122...4126.
2019	ID RUN	Performing ID Run.
2020	RESERVED	Not used.
2021	START ENABLE 1 MISSING	This alarm warns that the Start Enable 1 signal is missing. <ul style="list-style-type: none"> To control Start Enable 1 function, use parameter 1608. To correct, check: <ul style="list-style-type: none"> Digital input configuration. Communication settings.
2022	START ENABLE 2 MISSING	This alarm warns that the Start Enable 2 signal is missing. <ul style="list-style-type: none"> To control Start Enable 2 function, use parameter 1609. To correct, check: <ul style="list-style-type: none"> Digital input configuration. Communication settings.
2023	EMERGENCY STOP	Emergency stop activated.
2024	OBSOLETE	
2025	FIRST START	Signals that a the drive is performing a First Start evaluation of motor characteristics. This is normal the first time the motor is run after motor parameters are entered or changed. See parameter 9910 ID RUN for a description of motor models.
2026	RESERVED	Not used.
2027	USER LOAD CURVE	This alarm warns that the condition defined by parameter 3701 USER LOAD C MODE has been valid longer than half of the time defined by 3703 USER LOAD C TIME.
2028	START DELAY	Shown during the Start delay. See parameter 2113 START DELAY.

Note 1. Even when the relay output is configured to indicate alarm conditions (e.g. parameter 1401 RELAY OUTPUT 1 = 5 (ALARM) or 16 (FLT/ALARM)), this alarm is not indicated by a relay output.

Maintenance



WARNING! Read chapter [Safety](#) on page [5](#) before performing any maintenance on the equipment. Ignoring the safety instructions can cause injury or death.

Maintenance intervals

If installed in an appropriate environment, the drive requires very little maintenance. This table lists the routine maintenance intervals recommended by ABB.

Maintenance	Interval	Instruction
Heatsink temperature check and cleaning	Depends on the dustiness of the environment (every 6...12 months)	See Heatsink on page 261 .
Main cooling fan replacement	Every six years	See Main fan replacement on page 262 .
Internal enclosure cooling fan replacement (IP54 / UL type 12 drives)	Every three years.	See Internal enclosure fan replacement on 264 .
Capacitor reforming	Every year when stored	See Reforming on page 265 .
Capacitor replacement (frame sizes R5 and R6)	Every nine years	See Replacement on page 265 .
Replace battery in the ACQ Control Panel	Every ten years	See Battery on page 265 .

Consult your local ABB Service representative for more details on the maintenance. On the Internet, go to www.abb.com/drive and select *Drive Services – Maintenance and Field Services*.

Heatsink

The heatsink fins accumulate dust from the cooling air. Since a dusty heatsink is less efficient at cooling the drive, overtemperature faults become more likely. In a “normal” environment (not dusty, not clean) check the heatsink annually, in a dusty environment check more often.

Clean the heatsink as follows (when necessary):

1. Remove power from the drive.
2. Remove the cooling fan (see section [Main fan replacement](#) on page [262](#)).
3. Blow clean compressed air (not humid) from bottom to top and simultaneously use a vacuum cleaner at the air outlet to trap the dust.

Note: If there is a risk of the dust entering adjoining equipment, perform the cleaning in another room.

4. Reinstall the cooling fan.
5. Restore power.

Main fan replacement

The drive's main cooling fan has a life span of about 60 000 operating hours at maximum rated operating temperature and drive load. The expected life span doubles for each 10 °C (18 °F) drop in the fan temperature (fan temperature is a function of ambient temperatures and drive loads).

Fan failure can be predicted by the increasing noise from fan bearings and the gradual rise in the heatsink temperature in spite of heatsink cleaning. If the drive is operated in a critical part of a process, fan replacement is recommended once these symptoms start appearing. Replacement fans are available from ABB. Do not use other than ABB specified spare parts.

Frame sizes R1...R4

To replace the fan:

1. Remove power from the drive.
2. Remove drive cover.
3. For frame size:
 - R1, R2: Press together the retaining clips on the fan cover sides, and lift.
 - R3, R4: Press in on the lever located on the left side of the fan mount, and rotate the fan up and out.
4. Disconnect the fan cable.
5. Reinstall the fan in reverse order.
6. Restore power.

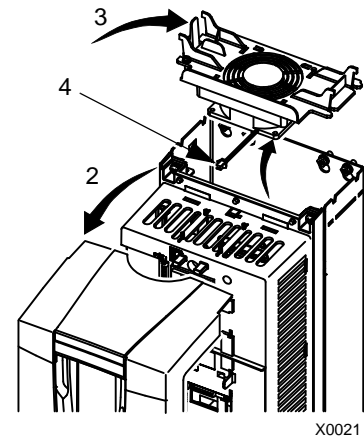

X0021

Frame size R5

To replace the fan:

1. Remove power from drive.
2. Remove the screws attaching the fan.
3. Remove the fan: Swing the fan out on its hinges.
4. Disconnect the fan cable.
5. Reinstall the fan in reverse order.
6. Restore power.

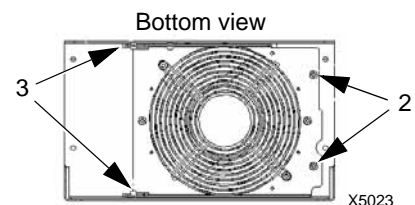

X5023

Arrows in the fan show the directions of the rotation and air flow.

Frame size R6

To replace the fan:

1. Remove power from the drive.
2. Remove the screw attaching the fan casing and let the casing lean down against the limiters.
3. Slide out the cable connector and disconnect it.
4. Take off the casing and replace the fan onto the casing's pins.
5. Reinstall the casing in reverse order.
6. Restore power.

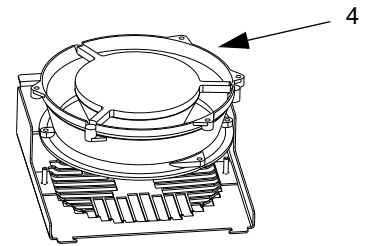
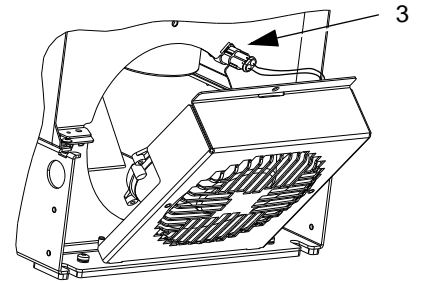
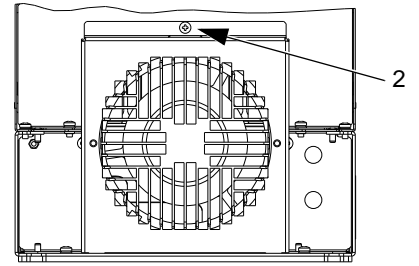

Internal enclosure fan replacement

IP54 / UL type 12 enclosures have an additional internal fan to circulate air inside the enclosure.

Frame sizes R1...R4

To replace the internal enclosure fan in frame sizes R1 to R3 (located at the top of the drive) and R4 (located in front of the drive):

1. Remove power from the drive.
2. Remove the front cover.
3. The housing that holds the fan in place has barbed retaining clips at each corner. Press all four clips toward the center to release the barbs.
4. When the clips/barbs are free, pull the housing up to remove from the drive.
5. Disconnect the fan cable.
6. Install the fan in reverse order, noting that:
 - The fan air flow is up (refer to the arrow on fan).
 - The fan wire harness is toward the front.
 - The notched housing barb is located in the right-rear corner.
 - The fan cable connects just forward of the fan at the top of the drive.

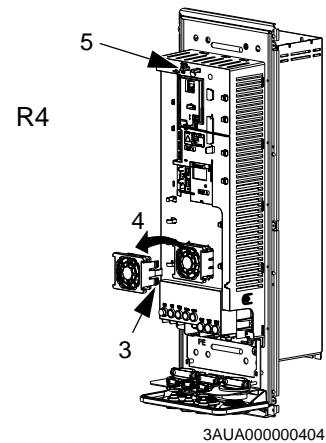
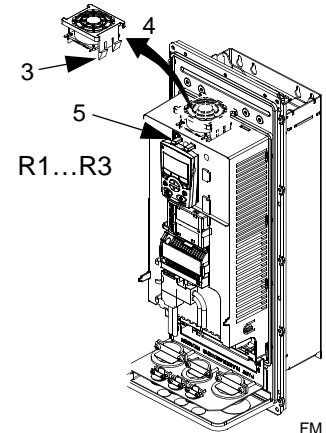

Frame sizes R5 and R6

To replace the internal enclosure fan in frame sizes R5 or R6:

1. Remove power from the drive.
2. Remove the front cover.
3. Lift the fan out and disconnect the cable.
4. Install the fan in reverse order.
5. Restore power.

Capacitors

Reforming

The drive DC link capacitors need to be reformed (re-aged) if the drive has been non-operational for more than one year. Without reforming, capacitors may be damaged when the drive starts to operate. It is therefore recommended to reform the capacitors once a year. See section [Serial number](#) on page 13 for how to check the date of manufacture from the serial number shown on the drive labels.

For information on reforming the capacitors, refer to *Guide for Capacitor Reforming in ACS50, ACS55, ACS150, ACS310, ACS320, ACS350, ACS550, ACH550 and ACQ550* (3AFE68735190 [English]), available on the Internet (go to www.abb.com and enter the code in the Search field).

Replacement

The drive intermediate circuit employs several electrolytic capacitors. Their life span is from 35 000...90 000 hours depending on drive loading and ambient temperature. Capacitor life can be prolonged by lowering the ambient temperature.

It is not possible to predict a capacitor failure. Capacitor failure is usually followed by a input power fuse failure or a fault trip. Contact ABB if capacitor failure is suspected. Replacements for frame size R5 and R6 are available from ABB. Do not use other than ABB specified spare parts.

Control panel

Cleaning

Use a soft damp cloth to clean the control panel. Avoid harsh cleaners which could scratch the display window.

Battery

A battery is used for ACQ Control Panels. The battery keeps the clock operating in memory during power interruptions.

The expected life for the battery is greater than ten years. To remove the battery, use a coin to rotate the battery holder on the back of the control panel. Replace the battery with type CR2032.

Note: The battery is NOT required for any control panel or drive function, except the clock.

Technical data

Ratings

By type designation, the table below provides ratings for the ACQ550 adjustable speed AC drive, including:

- IEC ratings
- NEMA ratings (shaded columns)
- frame size.

Ratings, 208...240 V drives

Abbreviated column headers are described in section [Symbols](#) on page 269.

Type ACQ550-x1- see below	Normal use			Heavy-duty use			Frame size
	I_{2N} A	P_N kW	P_N hp	I_{2hd} A	P_{hd} kW	P_{hd} hp	
Three-phase supply voltage, 208...240 V							
-04A6-2	4.6	0.75	1	3.5	0.55	0.75	R1
-06A6-2	6.6	1.1	1.5	4.6	0.75	1	R1
-07A5-2	7.5	1.5	2	6.6	1.1	1.5	R1
-012A-2	11.8	2.2	3	7.5	1.5	2	R1
-017A-2	16.7	4	5	11.8	2.2	3	R1
-024A-2	24.2	5.5	7.5	16.7	4	5	R2
-031A-2	30.8	7.5	10	24.2	5.5	7.5	R2
-046A-2	46.2	11	15	30.8	7.5	10	R3
-059A-2	59.4	15	20	46.2	11	15	R3
-075A-2	74.8	18.5	25	59.4	15	20	R4
-088A-2	88.0	22	30	74.8	18.5	25	R4
-114A-2	114	30	40	88.0	22	30	R4
-143A-2	143	37	50	114	30	40	R6
-178A-2	178	45	60	150	37	50	R6
-221A-2	221	55	75	178	45	60	R6
-248A-2	248	75	100	192	55	75	R6

00467918.xls C

Ratings, 380...480 V drives

Abbreviated column headers are described in section [Symbols](#) on page 269.

Type ACQ550-x1- see below	Normal use			Heavy-duty use			Frame size
	I_{2N} A	P_N kW	P_N hp	I_{2hd} A	P_{hd} kW	P_{hd} hp	
Three-phase supply voltage, 380...480 V							
-03A3-4	3.3	1.1	1.5	2.4	0.75	1	R1
-04A1-4	4.1	1.5	2	3.3	1.1	1.5	R1
-06A9-4	6.9	3	3	5.4	2.2	3	R1
-08A8-4	8.8	4	5	6.9	3	3	R1
-012A-4	11.9	5.5	7.5	8.8	4	5	R1
-015A-4	15.4	7.5	10	11.9	5.5	7.5	R2
-023A-4	23	11	15	15.4	7.5	10	R2
-031A-4	31	15	20	23	11	15	R3
-038A-4	38	18.5	25	31	15	20	R3
-045A-4	45	22	30	38	18.5	25	R3
-059A-4	59	30	40	44	22	30	R4
-072A-4	72	37	50	59	30	40	R4
-078A-4	77	Note 1	60	72	Note 1	50	R4
-097A-4	97	Note 1	75	77	Note 1	60	R4
-125A-4	125	Note 1	100	87	45	75	R5
-157A-4	157	75	125	124	55	100	R6
-180A-4	180	90	150	156	75	125	R6
-246A-4	246	110	200	192	110	150	R6

00467918.xls C

1. Not available in ACQ550-U1 series.

Ratings, 500...600 V drives

Abbreviated column headers are described in section [Symbols](#) on page 269.

Type	Normal use			Heavy-duty use			Frame size
ACQ550-U1- see below	I_{2N} A	P_N kW	P_N hp	I_{2hd} A	P_{hd} kW	P_{hd} hp	
Three-phase supply voltage, 500...600 V							
-02A7-6	2.8	1.5	2	2.4	1.1	1.5	R2
-03A9-6	4.0	2.2	3	2.7	1.5	2	R2
-06A1-6	6.3	4	5	3.9	2.2	3	R2
-09A0-6	9.3	5.5	7.5	6.1	4	5	R2
-011A-6	12.0	7.5	10	9.0	5.5	7.5	R2
-017A-6	18.0	11	15	11	7.5	10	R2
-022A-6	23.0	15	20	17	11	15	R3
-027A-6	28.0	18.5	25	22	15	20	R3
-032A-6	33.0	22	30	27	18.5	25	R4
-041A-6	43.0	30	40	32	22	30	R4
-052A-6	54.0	37	50	41	30	40	R4
-062A-6	64.0	45	60	52	37	50	R4
-077A-6	80.0	55	75	62	45	60	R6
-099A-6	102.0	75	100	77	55	75	R6
-125A-6	129.0	90	125	99	75	100	R6
-144A-6	149.0	110	150	125	90	125	R6

00467918.xls C

Symbols

Typical ratings:

Normal use (10% overload capability)

I_{2N} continuous rms current. 10% overload is allowed for one minute in ten minutes.

P_N typical motor power in normal use. The kilowatt power ratings apply to most IEC, 4-pole motors. The horsepower ratings apply to most 4-pole NEMA motors.

Heavy-duty use (50% overload capability)

I_{2hd} continuous rms current. 50% overload is allowed for one minute in ten minutes.

P_{hd} typical motor power in heavy duty use. The kilowatt power ratings apply to most IEC, 4-pole motors. The horsepower ratings apply to most 4-pole NEMA motors.

Sizing

The current ratings are the same regardless of the supply voltage within one voltage range. To achieve the rated motor power given in the table, the rated current of the drive must be higher than or equal to the rated motor current. Also note that:

- the ratings apply for ambient temperature of 40 °C (104 °F)
- the maximum allowed motor shaft power is limited to $1.5 \cdot P_{hd}$. If the limit is exceeded, motor torque and current are automatically restricted. The function protects the input bridge of the drive against overload.

In multimotor systems, the output current of the drive must be equal to or greater than the calculated sum of the input currents of all motors.

Derating

The load capacity (current and power) decreases for certain situations, as defined below. In such situations, where full motor power is required, oversize the drive so that the derated value provides sufficient capacity.

For example, if your application requires 15.4 A of motor current and a 8 kHz switching frequency, calculate the appropriate drive size requirement as follows:

The minimum size required = $15.4 \text{ A} / 0.80 = 19.25 \text{ A}$

Where: 0.80 is the derating for 8 kHz switching frequency (see section [Switching frequency derating](#) on page 270).

Referring to I_{2N} in the ratings tables (starting from page 267), the following drives exceed the I_{2N} requirement of 19.25 A: ACQ550-x1-023A-4, or ACQ550-x1-024A-2.

Temperature derating

In the temperature range +40 °C...50 °C (+104 °F...122 °F), the rated output current is decreased 1% for every 1 °C (1.8 °F) above +40 °C (+104 °F). Calculate the output current by multiplying the current given in the rating table by the derating factor.

Example If the ambient temperature is 50 °C (+122 °F), the derating factor is $100\% - 1\%/^{\circ}\text{C} \cdot 10 \text{ }^{\circ}\text{C} = 90\%$ or 0.90.

The output current is then $0.90 \cdot I_{2N}$ or $0.90 \cdot I_{2hd}$.

Altitude derating

In altitudes 1000...4000 m (3300...13,200 ft) above sea level, the derating is 1% for every 100 m (330 ft). If the installation site is higher than 2000 m (6600 ft) above sea level, please contact your local ABB distributor or office for further information.

Single phase supply derating

For 208...240 V series drives, a single phase supply can be used. In that case, the derating is 50%.

Switching frequency derating

When using the 8 kHz switching frequency (parameter 2606),

- derate all rated currents and powers (including drive's overload currents) to 80%.

When using the 12 kHz switching frequency (parameter 2606),

- derate all rated currents and powers (including drive's overload currents) to 65% (to 50% for 600 V, R4 frame sizes, that is for ACQ550-U1-032A-6 ... ACQ550-U1-062A-6),
- derate ambient temperature maximum to 30 °C (86 °F).
- Note: The continuous maximum current is limited to I_{2hd} .

Note: Setting parameter 2607 SWITCH FREQ CTRL = 1 (ON) allows the drive to reduce the switching frequency if/when the drive's internal temperature exceeds 80 °C (with 12 kHz switching frequency) or 90 °C (with 8 kHz switching frequency). See the parameter description for 2607 for details.

Input power connections



WARNING! Do not operate the drive outside the nominal input line voltage range. Overvoltage can result in permanent damage to the drive.

Input power specifications

Input power (mains) connection specifications	
Voltage (U_1)	208/220/230/240 V AC 3-phase (or 1-phase) -15%...+10% for ACQ550-x1-xxxx-2. 380/400/415/440/460/480 V AC 3-phase -15%...+10% for ACQ550-x1-xxxx-4. 500/525/575/600 V AC 3-phase -15%...+10% for ACQ550-U1-xxxx-6.
Prospective short-circuit current (IEC 629)	Maximum allowed prospective short-circuit current in the supply is 100 kA providing that the input power cable of the drive is protected with appropriate fuses. US: 100 000 AIC.
Frequency	48...63 Hz
Imbalance	Max. \pm 3% of nominal phase to phase input voltage
Fundamental power factor ($\cos \phi_1$)	0.98 (at nominal load)
Cable temperature rating	90 °C (194 °F) rating minimum

Disconnecting device for isolation

Install a hand-operated input disconnecting device (disconnecting means) between the AC power source and the drive. The disconnecting device must be of a type that can be locked to the open position for installation and maintenance work.

- **Europe:** To meet the European Union Directives, according to standard EN 60204-1, Safety of Machinery, the disconnecting device must be one of the following types:
 - a switch-disconnector of utilization category AC-23B (EN 60947-3)
 - a disconnector having an auxiliary contact that in all cases causes switching devices to break the load circuit before the opening of the main contacts of the disconnector (EN 60947-3)
 - a circuit breaker suitable for isolation in accordance with EN 60947-2.
- **Other regions:** The disconnecting device must conform to the applicable safety regulations.

Fuses

Branch circuit protection must be provided by the end user and sized per national and local electric codes. The following tables provide fuse recommendations for short circuit protection on the drive's input power.

The rated fuse currents given in the tables are the maximums for the mentioned fuse types. If smaller fuse ratings are used, check that the fuse rms current rating is larger than the input current.

Check that the operating time of the fuse is below 0.5 seconds. The operating time depends on the fuse type, the supply network impedance as well as the cross-sectional area, material and length of the supply cable. In case the 0.5 seconds operating time is exceeded with the gG or T fuses, ultra rapid (aR) fuses will in most cases reduce the operating time to an acceptable level.

Fuses, 208...240 V drives

ACQ550-x1- see below	Input current A	Input power (mains) fuses		
		IEC 60269 gG (A)	UL Class T (A)	Bussmann type
-04A6-2	4.6	10	10	JJS-10
-06A6-2	6.6			
-07A5-2	7.5			
-012A-2	11.8	16	15	JJS-15
-017A-2	16.7	25	25	JJS-25
-024A-2	24.2		25	JJS-25
-031A-2	30.8	40	40	JJS-40
-046A-2	46.2	63	60	JJS-60
-059A-2	59.4		80	JJS-80
-075A-2	74.8	80	100	JJS-100
-088A-2	88.0	100	110	JJS-110
-114A-2	114	125	150	JJS-150
-143A-2	143	200	200	JJS-200
-178A-2	178	250	250	JJS-250
-221A-2	221	315	300	JJS-300
-248A-2	248		350	JJS-350

00467918.xls C

Fuses, 380...480 V drives

ACQ550-x1- see below	Input current A	Input power (mains) fuses		
		IEC 60269 gG (A)	UL Class T (A)	Bussmann type
-03A3-4	3.3	10	10	JJS-10
-04A1-4	4.1			
-06A9-4	6.9			
-08A8-4	8.8	10	10	JJS-15
-012A-4	11.9	16	16	JJS-15
-015A-4	15.4	16	16	JJS-20
-023A-4	23	25	30	JJS-30
-031A-4	31	35	40	JJS-40
-038A-4	38	50	50	JJS-50
-045A-4	45		60	JJS-60
-059A-4	59	63	80	JJS-80
-072A-4	72	80	90	JJS-90
-078A-4	77		100	JJS-100
-097A-4	97	125	80	JJS-110

ACQ550-x1- see below	Input current A	Input power (mains) fuses		
		IEC 60269 gG (A)	UL Class T (A)	Bussmann type
-125A-4	125	160	150	JJS-150
-157A-4	157	200	160	JJS-200
-180A-4	180	250	200	JJS-250
-246A-4	246	250	250	JJS-250

00467918.xls C

Fuses, 500...600 V drives

ACQ550-U1- see below	Input current A	Input power (mains) fuses		
		IEC 60269 gG (A)	UL Class T (A)	Bussmann type
-02A7-6	2.7	10	10	JJS-10
-03A9-6	3.9			
-06A1-6	6.1			
-09A0-6	9.0	16	15	JJS-15
-011A-6	11			
-017A-6	17	25	25	JJS-25
-022A-6	22			
-027A-6	27	35	40	JJS-40
-032A-6	32			
-041A-6	41	50	50	JJS-50
-052A-6	52	60	60	JJS-60
-062A-6	62	80	80	JJS-80
-077A-6	77		100	JJS-100
-099A-6	99	125	150	JJS-150
-125A-6	125	160	175	JJS-175
-144A-6	144	200	200	JJS-200

00467918.xls C

Emergency stop devices

The overall design of the installation must include emergency stop devices and any other safety equipment that may be needed. Pressing STOP on the drive's control panel does NOT:

- generate an emergency stop of the motor
- separate the drive from dangerous potential.

Input power cables/wiring

Input wiring can be any of:

- a four conductor cable (three phases and ground/protective earth). Shielding is not required.
- four insulated conductors routed through conduit.

Size wiring according to local safety regulations, appropriate input voltage and the drive's load current. In any case, the conductor must be less than the maximum limit defined by the terminal size (see section [Drive's power connection terminals](#) on page 276).

The table below lists copper and aluminium cable types for different load currents. These recommendations apply only for the conditions listed at the top of the table.

IEC				NEC	
Based on:				Based on:	
<ul style="list-style-type: none"> • EN 60204-1 and IEC 60364-5-2/2001 • PVC insulation • 30 °C (86 °F) ambient temperature • 70 °C (158 °F) surface temperature • cables with concentric copper shield • not more than nine cables laid on cable ladder side by side. 				<ul style="list-style-type: none"> • NEC Table 310-16 for copper wires • 90 °C (194 °F) wire insulation • 40 °C (104 °F) ambient temperature • not more than three current-carrying conductors in raceway or cable, or earth (directly buried) • copper cables with concentric copper shield. 	
Max. load current A	Cu cable mm ²	Max. load current A	Al cable mm ²	Max. load current A	Cu wire size AWG/kcmil
14	3x1.5	Aluminium cable cannot be used with frame sizes R1...R5 because of its lower capacity.		22.8	14
20	3x2.5			27.3	12
27	3x4			36.4	10
34	3x6			50.1	8
47	3x10			68.3	6
62	3x16			86.5	4
79	3x25			100	3
98	3x35			91	3x50
119	3x50	117	3x70	137	1
153	3x70	143	3x95	155	1/0
186	3x95	165	3x120	178	2/0
215	3x120	191	3x150	205	3/0
249	3x150	218	3x185	237	4/0
284	3x185	257	3x240	264	250 MCM or 2 x 1
330	3x240	274	3x (3x50)	291	300 MCM or 2 x 1/0
		285	2x (3x95)	319	350 MCM or 2 x 2/0

Ground connections

For personnel safety, proper operation and reduction of electromagnetic emission/pick-up, the drive and the motor must be grounded at the installation site.

- Conductors must be adequately sized as required by safety regulations.
- Power cable shields must be connected to the drive PE terminal in order to meet safety regulations.
- Power cable shields are suitable for use as equipment grounding conductors only when the shield conductors are adequately sized as required by safety regulations.
- In multiple drive installations, do not connect drive terminals in series.

Corner grounded TN systems



WARNING! Do not attempt to install or remove the EMC filter screws EM1, EM3, F1 or F2 while power is applied to the drive's input terminals.

Corner grounded TN systems are defined in the following table. In such systems, disconnect the internal ground connection through the EMC filter capacitors (do this also if the grounding configuration of the system is unknown), see section [Disconnecting the internal EMC filter](#) on page 23.

Corner grounded TN systems – EMC filter must be disconnected			
Grounded at the corner of the delta		Grounded at the mid point of a delta leg	
Single phase, grounded at an end point		Three phase "Variac" without solidly grounded neutral	

The EMC filter capacitors make an internal ground connection that reduces electro-magnetic emission. Where EMC (electromagnetic compatibility) is a concern, and the system is symmetrically grounded, the EMC filter may be connected. For reference, the diagram on the right illustrates a symmetrically grounded TN system (TN-S system).

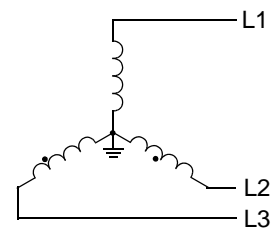

IT systems



WARNING! Do not attempt to install or remove the EMC filter screws EM1, EM3, F1 or F2 while power is applied to the drive's input terminals.

For IT systems (an ungrounded power system or a high-resistance-grounded [over 30 ohm] power system):

- Disconnect the ground connection to the internal EMC filter, see section [Disconnecting the internal EMC filter](#) on page 23.
- Where EMC requirements exist, check for excessive emission propagated to neighboring low voltage networks. In some cases, the natural suppression in transformers and cables is sufficient. If in doubt, use a supply transformer with static screening between the primary and secondary windings.
- Do NOT install an external RFI/EMC filter. Using an EMC filter grounds the input power through the filter capacitors, which could be dangerous and could damage the drive.

Drive's power connection terminals

The following table provides specifications for the drive's power connection terminals.

Frame size	U1, V1, W1 U2, V2, W2 BRK±, UDC± terminals						Earthing PE terminal			
	Minimum wire size		Maximum wire size		Tightening torque		Maximum wire size		Tightening torque	
	mm ²	AWG	mm ²	AWG	N-m	lb-ft	mm ²	AWG	N-m	lb-ft
R1 ¹	0.75	18	16	6	1.3	1	16	6	1.3	1
R2 ¹	0.75	18	16	6	1.3	1	16	6	1.3	1
R3 ¹	2.5	14	25	3	2.7	2	25	3	2.7	2
R4 ¹	10	8	50	1/0	5.6	4	50	110	5.6	4
R5 ¹	16	6	70	2/0	15	11	70	2/0	15	11
R6 ²	95 ³	3/0 ³	105	350 MCM	40	30	105	350 MCM	40	30

00467918.xls C

¹ Aluminium cable cannot be used with frame sizes R1...R5 because of its lower capacity.

² Aluminium cable cannot be used with type ACQ550-01-290A-4 because of the terminal size.

³ See section [Power terminal considerations – R6 frame size](#) on page 277.

Note: See the recommended cable sizes for different load currents in section [Input power cables/wiring](#) on page 274.

Power terminal considerations – R6 frame size



WARNING! For R6 power terminals, if screw-on terminal lugs are supplied, they can only be used for wire sizes that are 95 mm² (3/0 AWG) or larger. Smaller wires will loosen and may damage the drive. They require crimp-on ring lugs as described below.

Crimp-on ring lugs

On the R6 frame size, if screw-on terminal lugs are supplied but the cable size used is less than 95 mm² (3/0 AWG), or if no screw-on terminal lugs are supplied at all, use crimp-on ring lugs according to the following procedure.

1. Select appropriate ring lugs from the following table.
2. Remove the screw-on terminal lugs, if supplied.
3. Attach the ring lugs to the drive end of the cables.
4. Isolate the ends of the ring lugs with insulating tape or shrink tubing.
5. Attach the ring lugs to the drive.

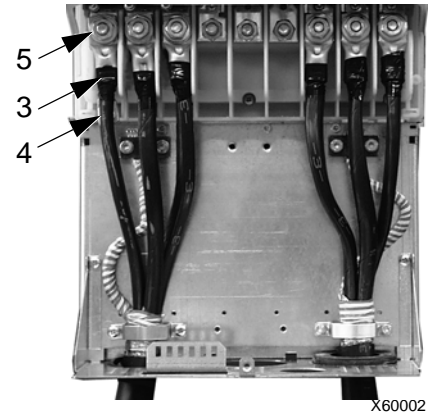

Wire size		Manufacturer	Ring lug	Crimping tool	No. of crimps
mm ²	kcmil/ AWG				
16	6	Burndy	YAV6C-L2	MY29-3	1
		IlSCO	CCL-6-38	ILC-10	2
25	4	Burndy	YA4C-L4BOX	MY29-3	1
		IlSCO	CCL-4-38	MT-25	1
35	2	Burndy	YA2C-L4BOX	MY29-3	2
		IlSCO	CRC-2	IDT-12	1
		IlSCO	CCL-2-38	MT-25	1
50	1	Burndy	YA1C-L4BOX	MY29-3	2
		IlSCO	CRA-1-38	IDT-12	1
		IlSCO	CCL-1-38	MT-25	1
		Thomas & Betts	54148	TBM-8	3
55	1/0	Burndy	YA25-L4BOX	MY29-3	2
		IlSCO	CRB-0	IDT-12	1
		IlSCO	CCL-1/0-38	MT-25	1
		Thomas & Betts	54109	TBM-8	3

Wire size		Manufacturer	Ring lug	Crimping tool	No. of crimps
mm ²	kcmil/ AWG				
70	2/0	Burndy	YAL26T38	MY29-3	2
		IlSCO	CRA-2/0	IDT-12	1
		IlSCO	CCL-2/0-38	MT-25	1
		Thomas & Betts	54110	TBM-8	3
95	3/0	Burndy	YAL27T38	MY29-3	2
		IlSCO	CRA-3/0	IDT-12	1
		IlSCO	CCL-3/0-38	MT-25	1
		Thomas & Betts	54111	TBM-8	3
95	3/0	Burndy	YA28R4	MY29-3	2
		IlSCO	CRA-4/0	IDT-12	1
		IlSCO	CCL-4/0-38	MT-25	2
		Thomas & Betts	54112	TBM-8	4

Screw-on terminal lugs

Use the following procedure to attach cables if screw-on terminal lugs are supplied and the cable size is 95 mm² (3/0 AWG) or larger.

1. Attach the supplied screw-on lugs to the drive end of the cables.
2. Attach screw-on lugs to the drive.

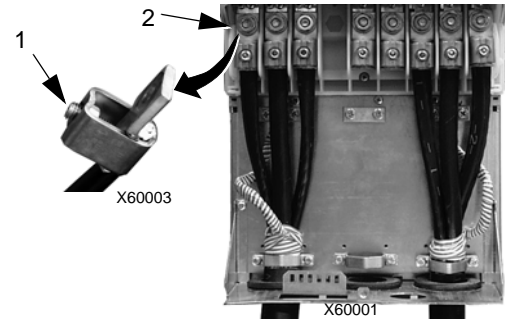

Motor connections



WARNING! Never connect line power to the drive output terminals: U2, V2 or W2. Line voltage applied to the output can result in permanent damage to the drive. If frequent bypassing is required, use mechanically interlocked switches or contactors.



WARNING! Do not connect any motor with a nominal voltage less than one half of the drive's nominal input voltage.



WARNING! Disconnect the drive before conducting any voltage tolerance (Hi-Pot) test or insulation resistance (Megger) test on the motor or motor cables. Do not conduct these tests on the drive.

Motor connection specifications

Motor connection specifications														
Voltage (U_2)	0... U_1 , 3-phase symmetrical, U_{max} at the field weakening point													
Frequency	0...500 Hz													
Frequency resolution	0.01 Hz													
Current	See section Ratings on page 267.													
Field weakening point	10...500 Hz													
Switching frequency	Selectable. See the availability in the table below.													
		<table border="1"> <thead> <tr> <th></th> <th>1, 2, 4 and 8 kHz</th> <th>12 kHz</th> </tr> </thead> <tbody> <tr> <td>208...240 V</td> <td>All types</td> <td>Frame sizes R1...R4 in scalar control mode</td> </tr> <tr> <td>380...480 V</td> <td>All types</td> <td>Frame sizes R1...R4 (except ACQ550-01-097A-4) in scalar control mode</td> </tr> <tr> <td>500...600 V</td> <td>All types</td> <td>Frame sizes R2...R4 in scalar control mode</td> </tr> </tbody> </table>		1, 2, 4 and 8 kHz	12 kHz	208...240 V	All types	Frame sizes R1...R4 in scalar control mode	380...480 V	All types	Frame sizes R1...R4 (except ACQ550-01-097A-4) in scalar control mode	500...600 V	All types	Frame sizes R2...R4 in scalar control mode
		1, 2, 4 and 8 kHz	12 kHz											
	208...240 V	All types	Frame sizes R1...R4 in scalar control mode											
380...480 V	All types	Frame sizes R1...R4 (except ACQ550-01-097A-4) in scalar control mode												
500...600 V	All types	Frame sizes R2...R4 in scalar control mode												
Cable temperature rating	90 °C (194 °F) rating minimum.													
Maximum motor cable length	See section Motor cable lengths on page 279.													

Motor cable lengths

Maximum motor cable lengths for 400 V and 600 V drives are given in the sections below.

In multimotor systems, the calculated sum of all motor cable lengths must not exceed the maximum motor cable length given in the appropriate table below.

Motor cable length for 400 V drives

The table below shows the maximum motor cable lengths for 400 V drives with different switching frequencies. Examples for using the table are also given.

Maximum cable length for 400 V drives																				
Frame size	EMC limits												Operational limits							
	Second environment (category C3 ¹)						First environment (category C2 ¹)						Basic unit				With du/dt filters			
	1 kHz		4 kHz		8 kHz		1 kHz		4 kHz		8 kHz		1/4 kHz		8/12 kHz		m		ft	
	m	ft	m	ft	m	ft	m	ft	m	ft	m	ft	m	ft	m	ft	m	ft	m	ft
R1	300	980	300	980	300	980	300	980	300	980	300	980	100	330	100	330	150	490		
R2	300	980	300	980	300	980	300	980	100	330	30	98	200	660	100	330	250	820		
R3	300	980	300	980	300	980	300	980	75	245	75	245	200	660	100	330	250	820		
R4	300	980	300	980	300	980	300	980	75	245	75	245	200	660	100	330	300	980		
R5	100	330	100	330	100	330	100	330	100	330	100	330	300	980	150 ²	490 ²	300	980		
R6	100	330	100	330	³	³	100	330	100	330	³	³	300	980	150 ²	490 ²	300	980		

¹ See the new terms in section [IEC/EN 61800-3 \(2004\) Definitions](#) on page 301.

² 12 kHz switching frequency is not available.

³ Not tested.

Sine filters further extend the cable lengths.

Under heading “Operational limits”, the “Basic unit” columns define the cable lengths with which the basic drive unit works without problems within the drive specification, without installing any further options. Column “With du/dt filters” defines the cable lengths when an external du/dt filter is used.

The columns under heading “EMC limits” show the maximum cable lengths with which the units have been tested for EMC emissions. The factory guarantees that these cable lengths meet the EMC standard requirements.

If external sine filters are installed, longer cable lengths can be used. With sine filters the limiting factors are the voltage drop of the cable, which has to be taken into account in engineering, as well as the EMC limits (where applicable).

The default switching frequency is 4 kHz.



WARNING! Using a motor cable longer than specified in the table above may cause permanent damage to the drive.

Examples for using the table:

Requirements	Checking and conclusions
R1 frame size, 8 kHz fsw, Category C2, 150 m (490 ft) cable	Check operational limits for R1 and 8 kHz -> for a 150 m (490 ft) cable a du/dt filter is needed. Check EMC limits -> EMC requirements for Category C2 are met with a 150 m (490 ft) cable.

Requirements	Checking and conclusions
R3 frame size, 4 kHz fsw, Category C3, 300 m (980 ft) cable	Check operational limits for R3 and 4 kHz -> a 300 m (980 ft) cable cannot be used even with a du/dt filter. A sine filter must be used and the voltage drop of the cable must be taken into account in the installation. Check EMC limits -> EMC requirements for Category C3 are met with a 300 m (980 ft) cable.
R5 frame size, 8 kHz fsw, Category C3, 150 m (490 ft) cable	Check operational limits for R5 and 8 kHz -> for a 150 m (490 ft) cable the basic unit is sufficient. Check EMC limits -> EMC requirements for Category C3 cannot be met with a 300 m (980 ft) cable. The installation configuration is not possible. An EMC plan is recommended to overcome the situation.
R6 frame size, 4 kHz fsw, EMC limits not applicable, 150 m (490 ft) cable	Check operational limits for R6 and 4 kHz -> for a 150 m (490 ft) cable the basic unit is sufficient. EMC limits do not need to be checked as there are no EMC requirements.

Motor cable length for 600 V drives

The table below shows the maximum motor cable lengths for 600 V drives with different switching frequencies. As the 600 V drives are not CE approved, cable lengths for EMC limits are not given.

Maximum cable length for 600 V drives				
Frame size	Operational limits			
	1/4 kHz		8/12 kHz	
	m	ft	m	ft
R2	100	330	100	330
R3...R4	200	660	100	330
R6	300	980	150 ²	490 ²

² 12 kHz switching frequency is not available.



WARNING! Using a motor cable longer than specified in the table above may cause permanent damage to the drive.

Motor thermal protection

According to regulations, the motor must be protected against thermal overload and the current must be switched off when overload is detected. The drive includes a motor thermal protection function that protects the motor and switches off the current when necessary. Depending on a drive parameter value (see parameter 3501 SENSOR TYPE), the function either monitors a calculated temperature value (based on a motor thermal model, see parameters 3005 MOT THERM PROT ... 3009 BREAK POINT FREQ) or an actual temperature indication given by motor temperature sensors (see [Group 35: MOTOR TEMP MEAS](#)). The user can tune the thermal model further by feeding in additional motor and load data.

The most common temperature sensors are:

- motor sizes IEC180...225: thermal switch (e.g. Klixon)
- motor sizes IEC200...250 and larger: PTC or PT100.

Ground fault protection

ACQ550 internal fault logic detects ground faults in the drive, motor, or motor cable. This fault logic:

- is NOT a personal safety or fire protection feature
 - can be disabled using parameter 3017 EARTH FAULT
- Note:** Disabling earth fault (ground fault) may void the warranty.
- could be tripped by leakage currents (input power to ground) associated with long high capacitance motor cables.

Grounding and routing

Motor cable shielding

Motor cables require shielding using conduit, armored cable or shielded cable.

- Conduit – When using conduit:
 - Bridge joints with a ground conductor bonded to the conduit on each side of the joint.
 - Bond conduit run to the drive enclosure.
 - Use a separate conduit run for motor cables (also separate input power and control cables).
 - Use a separate conduit run for each drive.
- Armored cable – When using armored cable:
 - Use six-conductor (3 phases and 3 grounds), type MC continuous corrugated aluminium armor cable with symmetrical grounds.
 - Armored motor cable can share a cable tray with input power cables, but not with control cables.
- Shielded cable – For shielded cable details, see section [Motor cable requirements for CE & C-Tick compliance](#) on page 283.

Grounding

See section [Ground connections](#) on page 275.

For CE compliant installations and installations where EMC emissions must be minimized, see section [Effective motor cable shields](#) on page 284.

Drive's motor connection terminals

The drive's motor and input power terminals have the same specifications. See section [Drive's power connection terminals](#) on page 276.

Motor cable requirements for CE & C-Tick compliance

The requirements in this section apply for CE or C-Tick compliance.

Minimum requirement (CE & C-Tick)

The motor cable must be a symmetrical three conductor cable with a concentric PE conductor or a four conductor cable with a concentric shield, however, a symmetrical constructed PE conductor is always recommended. The following figure shows the minimum requirement for the motor cable shield (for example, MCMK, Draka NK Cables).

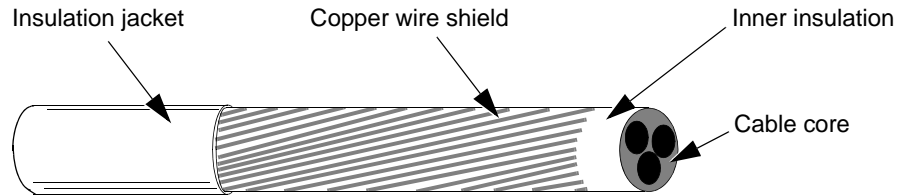

Recommendation for conductor layout

The following figure compares conductor layout features in motor cables.

<p>Recommended (CE & C-Tick) Symmetrical shielded cable: three phase conductors and a concentric or otherwise symmetrically constructed PE conductor, and a shield</p>	<p>Allowed (CE & C-Tick) A separate PE conductor is required if the conductivity of the cable shield is < 50% of the conductivity of the phase conductor.</p> <p>Allowed for motor cables with phase conductor cross section up to 10 mm².</p>
<p>Not allowed for motor cables (CE & C-Tick) A four-conductor system: three phase conductors and a protective conductor, without a shield.</p>	

Effective motor cable shields

The general rule for cable shield effectiveness is: the better and tighter the cable's shield, the lower the radiated emission level. The following figure shows an example of an effective construction (for example Ölflex-Servo-FD 780 CP, Lappkabel or MCCMK, NK Cables).

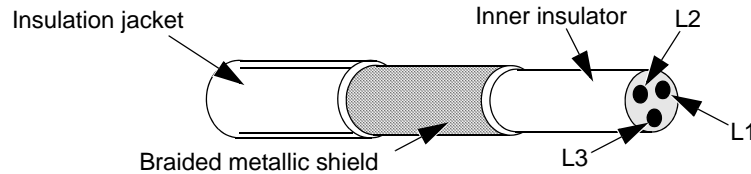

EN 61800-3 compliant motor cables

The most efficient EMC filtering can be achieved by following these rules:

- Motor cables must have an effective shield as described in section [Effective motor cable shields](#) on page 284.
- Motor cable shield wires must be twisted together into a bundle (pig-tail) – the bundle length must be less than five times its width – and connected to the terminal marked \perp (at the bottom right-hand corner of the drive).
- At the motor end, the motor cable shield must be earthed 360 degrees with an EMC cable gland, or the shield wires must be twisted together into a bundle (pig-tail) not longer than five times its width and connected to the PE terminal of the motor.
- See section [Motor cable length for 400 V drives](#), columns “*EMC limits*” on page 280 to check the maximum motor cable lengths and the need for filters for 400 V drives for IEC/EN 61800-3 compliance.



WARNING! Do not use RFI/EMC filters on IT systems.

Brake components

Availability

Braking availability for ACQ550 drives, by frame size is:

- R1 and R2 – a built-in brake chopper is standard equipment. Add appropriate resistor, as determined using the following section. Resistors are available from ABB.
- R3...R6 – does not include an internal brake chopper. Connect a chopper and a resistor, or a brake unit to the DC link terminals on the drive. Contact your ABB representative for appropriate parts.

Selecting the braking resistors (frame sizes R1 and R2)

Braking resistor must meet three requirements:

- Resistance must be always higher than the minimum value R_{MIN} defined for the drive type in the following tables. Never use resistance below this value.
- Resistance must be low enough to be able to produce the desired braking torque. To achieve the maximum braking torque (the larger of 150% of heavy duty or 110% of nominal duty), the resistance must not exceed R_{MAX} . If maximum braking torque is not necessary, resistor values can exceed R_{MAX} .
- The resistor power rating must be high enough to dissipate the braking power. This requirement involves many factors:
 - the maximum continuous power rating for the resistor(s)
 - the rate at which the resistor changes temperature (resistor thermal time constant)
 - maximum braking time ON – If the regeneration (braking) power is larger than the resistor rated power, there is a limit to the ON time, or the resistor overheats before the OFF period begins.
 - minimum braking time OFF – If the regeneration (braking) power is larger than the resistor rated power, the OFF time must be large enough for the resistor to cool between ON periods.

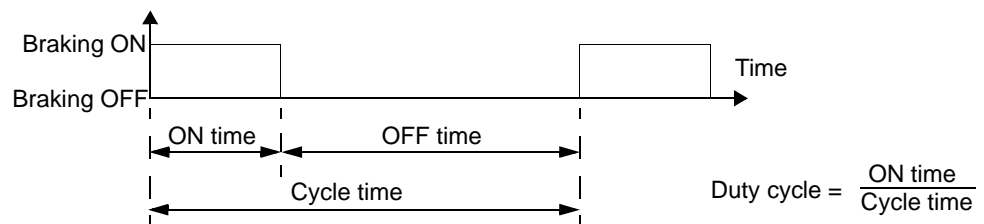

- the peak braking power requirement
- type of braking (deceleration to zero vs. overhauling load) – During deceleration to zero, the generated power steadily decreases, averaging half of the peak power. For an overhauling load, the braking is countering an external force (gravity for example) and the braking power is constant. The total heat generated from an overhauling load is double the heat generated from deceleration to zero speed (for the same peak torque and ON time).

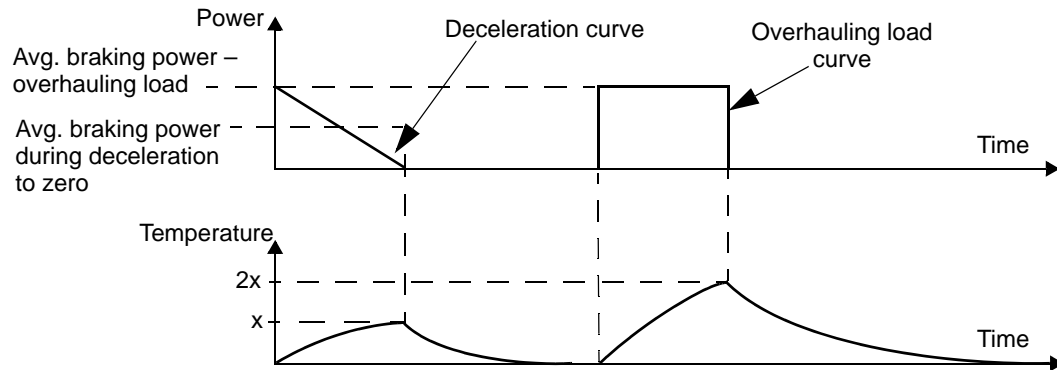

The many variables in the last requirement above are most easily dealt with using the following tables.

- First, determine your maximum braking time ON (ON_{MAX}), minimum braking time OFF (OFF_{MIN}) and load type (deceleration or overhauling load).
- Calculate duty cycle:

$$\text{Duty cycle} = \frac{ON_{MAX}}{(ON_{MAX} + OFF_{MIN})} \cdot 100\%$$

- In the appropriate table, find the column that best matches your data:
 - $ON_{MAX} \leq$ column specification and
 - Duty cycle \leq column specification
- Find the row that matches your drive.
- The minimum power rating for deceleration to zero is the value in the selected row/column.
- For overhauling loads, double the rating in the selected row/column, or use the “Continuous ON” column.

208...240 V drives

Type ACQ550-01/U1- see below	Resistance		Resistor ¹ minimum continuous power rating				
	R_{MAX}	R_{MIN}	Deceleration-to-zero rating				P_{rcont} Continuous ON > 60 s ON > 25% Duty
			P_{r3} ≤ 3 s ON ≥ 27 s OFF ≤ 10% Duty	P_{r10} ≤ 10 s ON ≥ 50 s OFF ≤ 17% Duty	P_{r30} ≤ 30 s ON ≥ 180 s OFF ≤ 14% Duty	P_{r60} ≤ 60 s ON ≥ 180 s OFF ≤ 25% Duty	
ohm	ohm	W	W	W	W	W	
Three-phase supply voltage, 208...240 V							
-04A6-2	234	80	45	80	120	200	1100
-06A6-2	160	80	65	120	175	280	1500
-07A5-2	117	44	85	160	235	390	2200
-012A-2	80	44	125	235	345	570	3000
-017A-2	48	44	210	390	575	950	4000
-024A-2	32	30	315	590	860	1425	5500
-031A-2	23	22	430	800	1175	1940	7500

¹ Resistor time constant specification must be ≥ 85 seconds.

380...480 V drives

Type ACQ550- 01/U1- see below	Resistance		Resistor ¹ minimum continuous power rating				
	R_{MAX}	R_{MIN}	Deceleration-to-zero rating				P_{rcont} Continuous ON > 60 s ON > 25% Duty
			P_{r3} ≤ 3 s ON ≥ 27 s OFF ≤ 10% Duty	P_{r10} ≤ 10 s ON ≥ 50 s OFF ≤ 17% Duty	P_{r30} ≤ 30 s ON ≥ 180 s OFF ≤ 14% Duty	P_{r60} ≤ 60 s ON ≥ 180 s OFF ≤ 25% Duty	
ohm	ohm	W	W	W	W	W	
Three-phase supply voltage, 380...480 V							
-03A3-4	641	120	65	120	175	285	1100
-04A1-4	470	120	90	160	235	390	1500
-05A4-4	320	120	125	235	345	570	2200
-06A9-4	235	80	170	320	470	775	3000
-08A8-4	192	80	210	400	575	950	4000
-012A-4	128	80	315	590	860	1425	5500
-015A-4	94	63	425	800	1175	1950	7500
-023A-4	64	63	625	1175	1725	2850	11000

¹ Resistor time constant specification must be ≥ 85 seconds.

500...600 V drives

Type ACQ550- U1- see below	Resistance		Resistor ¹ minimum continuous power rating				
	R_{MAX}	R_{MIN}	Deceleration-to-zero rating				P_{rcont} Continuous ON > 60 s ON > 25% Duty
			P_{r3} ≤ 3 s ON ≥ 27 s OFF ≤ 10% Duty	P_{r10} ≤ 10 s ON ≥ 50 s OFF ≤ 17% Duty	P_{r30} ≤ 30 s ON ≥ 180 s OFF ≤ 14% Duty	P_{r60} ≤ 60 s ON ≥ 180 s OFF ≤ 25% Duty	
ohm	ohm	W	W	W	W	W	
Three-phase supply voltage, 500...600 V							
-02A7-6	548	80	93	175	257	425	1462
-03A9-6	373	80	137	257	377	624	2144
-06A1-6	224	80	228	429	629	1040	3573
-09A0-6	149	80	342	643	943	1560	5359
-011A-6	110	60	467	877	1286	2127	7308
-017A-6	75	60	685	1286	1886	3119	10718

¹ Resistor time constant specification must be ≥ 85 seconds.



WARNING! Never use a brake resistor with a resistance below the minimum value specified for the particular drive. The drive and the internal chopper are not able to handle the overcurrent caused by the low resistance.

Symbols

R_{MIN} – Minimum allowed resistance of the braking resistor.

R_{MAX} – Maximum resistance allowed if maximum braking torque is necessary.

P_{rx} – Duty-cycle based resistor power rating in deceleration braking, where “x” is ON_{MAX} time.

Installing and wiring resistors

All resistors must be installed outside the drive module in a place where they can dissipate heat.



WARNING! The surface temperature of the resistor is very high, and air flowing from the resistor is very hot. Materials near the brake resistor must be non-flammable. Provide protection from accidental contact with the resistor.

To ensure that the input fuses protect the resistor cable, use resistor cables with the same rating as used for the power input to the drive.

The maximum length of the resistor cable(s) is 10 m (33 ft). See section [Power connection diagrams](#) on page 21 for the resistor cable connection points.

Mandatory circuit protection

The following setup is essential for safety – it interrupts the main supply in fault situations involving chopper shorts:

- Equip the drive with a main contactor.
- Wire the contactor so that it opens if the resistor thermal switch opens (an overheated resistor opens the contactor).

Below is a simple wiring diagram example.

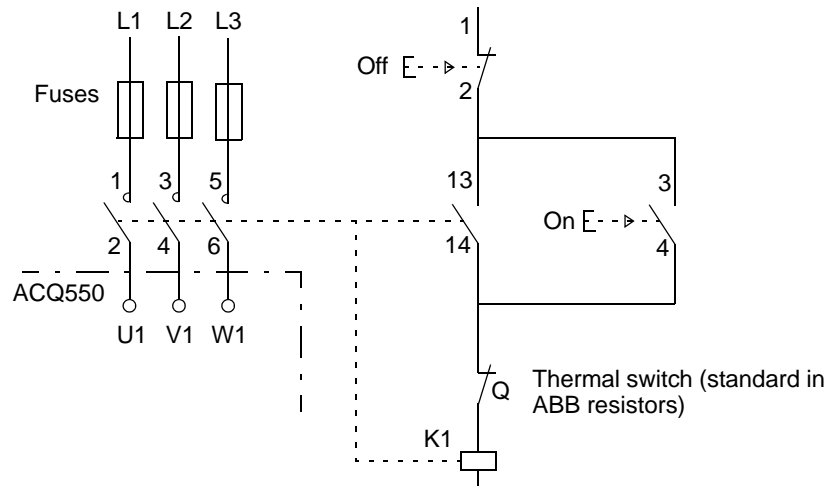

Parameter set-up

To enable dynamic braking, switch off the drive's overvoltage control [Set parameter 2005 = 0 (DISABLE)].

Control connections

Control connection specifications

Control connection specifications	
Analog inputs and outputs	See section Control terminals table on page 24.
Digital inputs	Digital input impedance 1.5 kohm. Maximum voltage for digital inputs is 30 V.
Relays (digital outputs)	<ul style="list-style-type: none"> • Max. contact voltage: 30 V DC, 250 V AC • Max. contact current / power: 6 A, 30 V DC; 1500 VA, 250 V AC • Max. continuous current: 2 A rms ($\cos \varphi = 1$), 1 A rms ($\cos \varphi = 0.4$) • Minimum load: 500 mW (12 V, 10 mA) • Contact material: Silver-nickel (AgN) • Isolation between relay digital outputs, test voltage: 2.5 kV rms, 1 minute
Cable specifications	See section Control terminals table on page 24.

Control cables

General recommendations

Use multi-core cables with a braided copper wire shield, temperature rated at 60 °C (140 °F) or above:

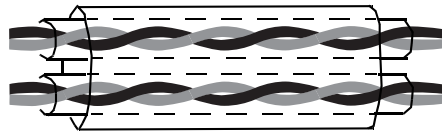

Double shielded
Example: JAMAK by Draka NK Cables

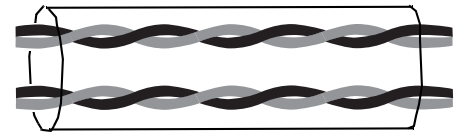

Single shielded
Example: NOMAK by Draka NK Cables

For digital and analog I/O cables, twist the shield together into a bundle (pig-tail) not longer than five times its width and connect it to terminal X1-1 at the drive end. Leave the other end of the cable shield unconnected.

For connecting the shield wires of the RS485 cable, see the instructions (and notes) in section [Mechanical and electrical installation – EFB](#) on page 179.

Route control cables to minimize radiation to the cable:

- Route as far away as possible from the input power and motor cables (at least 20 cm [8 in]).
- Where control cables must cross power cables, make sure they are at an angle as near 90° as possible.
- Stay at least 20 cm (8 in) from the sides of the drive.

Use care in mixing signal types on the same cable:

- Do not mix relay-controlled signals using more than 30 V and other control signals in the same cable.
- Run relay-controlled signals as twisted pairs (especially if voltage > 48 V). Relay-controlled signals using less than 48 V can be run in the same cables as digital input signals.

Note: Never mix 24 V DC and 115/230 V AC signals in the same cable.

Analog cables

Recommendations for analog signal runs:

- Use double shielded, twisted pair cable.
- Use one individually shielded pair for each signal.
- Do not use a common return for different analog signals.

Digital cables

Recommendation for digital signal runs: A double shielded cable is the best alternative, but single-shielded, twisted, multi-pair cable is also usable.

Control panel cable

If the control panel is connected to the drive with a cable, use only Category 5 Patch ethernet cable. The maximum length that is tested to meet EMC specifications is 3 m (9.8 ft). Longer cables are susceptible to electromagnetic noise and must be user-tested to verify that EMC requirements are met. Where long runs are required (especially for runs longer than about 12 m [40 ft]), use a RS232/RS485 converter at each end and run RS485 cable.

Drive's control connection terminals

The following table provides specifications for the drive's control terminals

Frame size	Control			
	Maximum wire size ¹		Tightening torque	
	mm ²	AWG	N-m	lb-ft
All	1.5	16	0.4	0.3

¹ Values given for solid wires.
For stranded wires, the maximum size is 1 mm².

Efficiency

Approximately 98% at nominal power level.

Cooling

Cooling specifications	
Method	Internal fan, flow direction from bottom to top.
Requirement	Free space above and below the ACQ550 drive: 200 mm (8 in). Free space is not required on the drive's sides – ACQ550 drives can be mounted side-by-side.

Air flow, 208...240 V drives

The following table lists heat loss and air flow data for 208...240 V drives.

Drive		Heat loss		Air flow	
ACQ550-x1-	Frame size	W	BTU/hr	m ³ /h	ft ³ /min
-04A6-2	R1	55	189	44	26
-06A6-2	R1	73	249	44	26
-07A5-2	R1	81	276	44	26
-012A-2	R1	116	404	44	26
-017A-2	R1	161	551	44	26
-024A-2	R2	227	776	88	52
-031A-2	R2	285	973	88	52
-046A-2	R3	420	1434	134	79
-059A-2	R3	536	1829	134	79
-075A-2	R4	671	2290	280	165
-088A-2	R4	786	2685	280	165
-114A-2	R4	1014	3463	280	165
-143A-2	R6	1268	4431	404	238
-178A-2	R6	1575	5379	404	238
-221A-2	R6	1952	6666	404	238
-248A-2	R6	2189	7474	404	238

00467918.xls C

Air flow, 380...480 V drives

The following table lists heat loss and air flow data for 380...480 V drives.

Drive		Heat loss		Air flow	
ACQ550-x1-	Frame size	W	BTU/hr	m ³ /h	ft ³ /min
-03A3-4	R1	40	137	44	26
-04A1-4	R1	52	178	44	26
-06A9-4	R1	97	331	44	26
-08A8-4	R1	127	434	44	26
-012A-4	R1	172	587	44	26
-015A-4	R2	232	792	88	52
-023A-4	R2	337	1151	88	52
-031A-4	R3	457	1561	134	79

Drive		Heat loss		Air flow	
ACQ550-x1-	Frame size	W	BTU/hr	m ³ /h	ft ³ /min
-038A-4	R3	562	1919	134	79
-045A-4	R3	667	2278	280	165
-059A-4	R4	907	3098	280	165
-072A-4	R4	1120	3825	280	165
-078A-4	R4	1295	4423	280	165
-097A-4	R4	1440	4918	250	147
-125A-4	R5	1940	6625	404	238
-157A-4	R6	2310	7889	404	238
-180A-4	R6	2810	9597	404	238
-246A-4	R6	3260	11134	540	318

00467918.xls C

Air flow, 500...600 V drives

The following table lists heat loss and air flow data for 500...600 V drives.

Drive		Heat loss		Air flow	
ACQ550-U1-	Frame size	W	BTU/hr	m ³ /h	ft ³ /min
-02A7-6	R2	46	157	88	52
-03A9-6	R2	68	232	88	52
-06A1-6	R2	124	423	88	52
-09A0-6	R2	170	581	88	52
-011A-6	R2	232	792	88	52
-017A-6	R2	337	1150	88	52
-022A-6	R3	457	1560	134	79
-027A-6	R3	562	1918	134	79
-032A-6	R4	667	2276	280	165
-041A-6	R4	907	3096	280	165
-052A-6	R4	1120	6820	280	165
-062A-6	R4	1295	4420	280	165
-077A-6	R6	1504	5136	404	238
-099A-6	R6	1821	6219	404	238
-125A-6	R6	2442	8339	404	238
-144A-6	R6	2813	9607	404	238

00467918.xls C

Dimensions and weights

The dimensions and mass for the ACQ550 depend on the frame size and enclosure type. If unsure of the frame size, first, find the "Type" designation on the drive labels (see sections [Type designation](#) on page 13 and [Drive labels](#) on page 12). Then look up that type designation in the rating tables (see chapter [Technical data](#), page 267), to determine the frame size.

Mounting dimensions

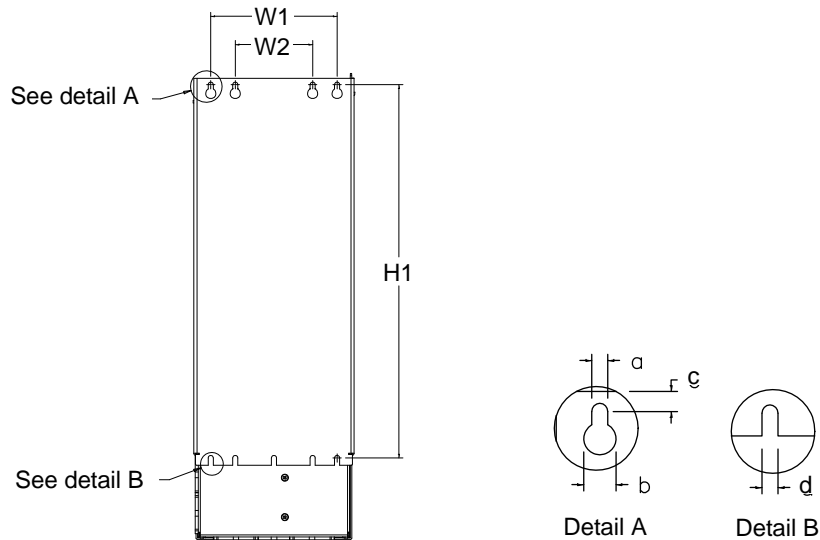

X0032

IP21 / UL type 1 and IP54 / UL type 12 – Dimensions for each frame size												
Ref.	R1		R2		R3		R4		R5		R6	
	mm	in	mm	in	mm	in	mm	in	mm	in	mm	in
W1 ¹	98.0	3.9	98.0	3.9	160	6.3	160	6.3	238	9.4	263	10.4
W2 ¹	--	--	--	--	98.0	3.9	98.0	3.9	--	--	--	--
H1 ¹	318	12.5	418	16.4	473	18.6	578	22.8	588	23.2	675	26.6
a	5.5	0.2	5.5	0.2	6.5	0.25	6.5	0.25	6.5	0.25	9.0	0.35
b	10.0	0.4	10.0	0.4	13.0	0.5	13.0	0.5	14.0	0.55	18.0	0.71
c	5.5	0.2	5.5	0.2	8.0	0.3	8.0	0.3	8.5	0.3	8.5	0.3
d	5.5	0.2	5.5	0.2	6.5	0.25	6.5	0.25	6.5	0.25	9.0	0.35

¹ Center to center dimension.

Outside dimensions

Drives with IP21 / UL type 1 enclosures

Types ACQ550-x1-246A-4 and
ACQ550-01-290A-4, frame size R6

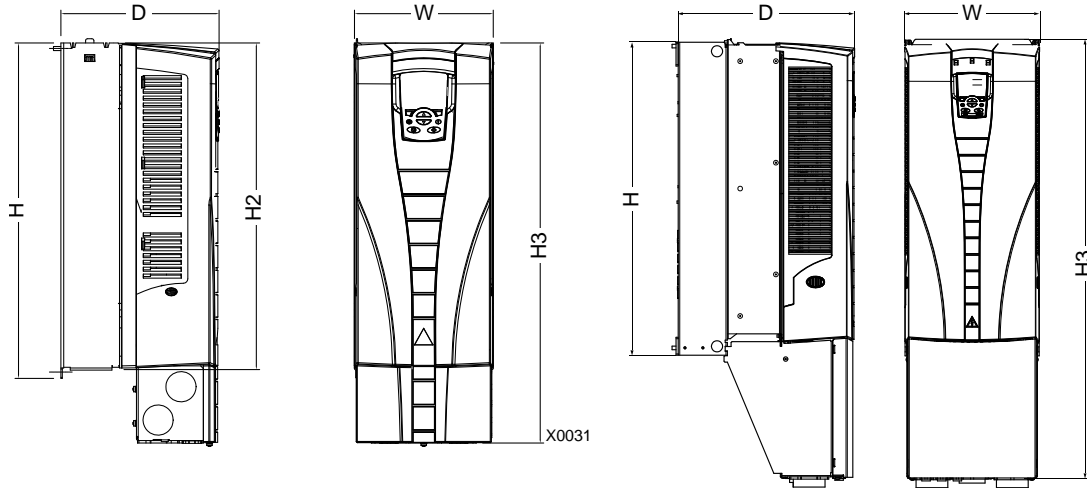

IP21 / UL type 1 – dimensions for each frame size												
Ref.	R1		R2		R3		R4		R5		R6	
	mm	in	mm	in	mm	in	mm	in	mm	in	mm	in
W	125	4.9	125	4.9	203	8.0	203	8.0	265	10.4	302	11.9
H	330	13.0	430	16.9	490	19.3	596	23.5	602	23.7	700	27.6
H2	315	12.4	415	16.3	478	18.8	583	23.0	578	22.8	698	27.5
H3	369	14.5	469	18.5	583	23.0	689	27.1	736	29.0	888 ¹	35.0 ¹
D	212	8.3	222	8.7	231	9.1	262	10.3	286	11.3	400	15.8

00467918.xls C

1. ACQ550-x1-246A-4 and ACQ550-01-290A-4: 979 mm / 38.5 in.

Drives with IP54 / UL type 12 enclosures

Type ACQ550-01-290A-4, IP54
(UL type 12 not available), frame size R6

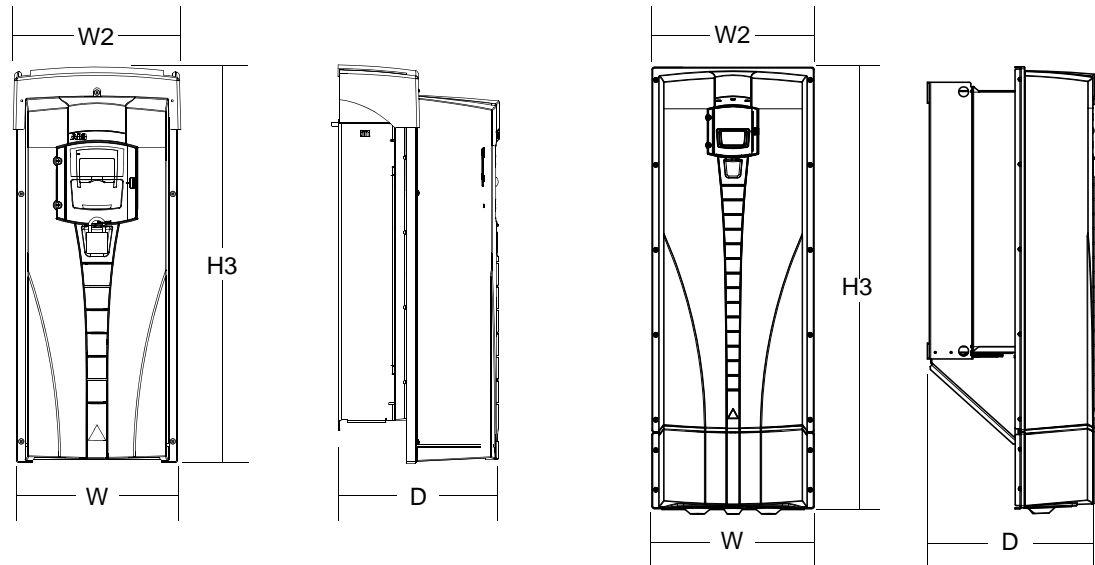

IP54 / UL type 12 – Dimensions for each frame size												
Ref.	R1		R2		R3		R4		R5		R6 ²	
	mm	in	mm	in	mm	in	mm	in	mm	in	mm	in
W	213	8.4	213	8.4	257	10.1	257	10.1	369	14.5	410	16.1
W2	222	8.8	222	8.8	267	10.5	267	10.5	369	14.5	410	16.1
H3	461	18.2	561	22.1	629	24.8	760	29.9	775	30.5	924 ¹	36.4 ¹
D	234	9.2	245	9.7	254	10.0	284	11.2	309	12.2	423	16.7

00467918.xls C

1. ACQ550-01-290A-4: 1119 mm / 44.1 in.
2. UL type 12 not available for ACQ550-01-290A-4.

Weight

The following table lists typical maximum weights for each frame size. Variations within each frame size (due to components associated with voltage/current ratings and options) are minor.

Enclosure	Weight											
	R1		R2		R3		R4		R5		R6	
	kg	lb	kg	lb	kg	lb	kg	lb	kg	lb	kg	lb
IP21 / UL type 1	6.5	14.3	9.0	19.8	16	35	24	53	34	75	69 ¹	152 ¹
IP54 / UL type 12	8.0	17.6	11.0	24.3	17.0	37.5	26.0	57.3	42.0	93.0	86.0 ²	190 ²

00467918.xls C

1. ACQ550-x1-246A-4, IP21 / UL type 1: 70 kg / 154 lb
2. ACQ550-x1-246A-4, IP54 / UL type 12: 80 kg / 176 lb.

Degrees of protection

Available enclosures:

- IP21 / UL type 1 enclosure. The site must be free of airborne dust, corrosive gases or liquids, and conductive contaminants such as condensation, carbon dust and metallic particles.
- IP54 / UL type 12 enclosure. This enclosure provides protection from airborne dust and light sprays or splashing water from all directions.

Note: UL type 12 enclosure is not available for type ACQ550-01-290A-4.

Compared to the IP21 / UL type 1 enclosure, the IP54 / UL type 12 enclosure has:

- the same internal plastic shell as the IP21 enclosure
- a different outer plastic cover
- an additional internal fan to improve cooling
- larger dimensions
- the same rating (does not require a derating).

Ambient conditions

The following table lists the ACQ550 environmental requirements.

Ambient environment requirements		
	Installation site	Storage and transportation in the protective package
Altitude	<ul style="list-style-type: none"> • 0...1000 m (0...3 300 ft) • 1000...2000 m (3 300...6 600 ft) if P_N and I_{2N} derated 1% every 100 m above 1000 m (300 ft above 3 300 ft) 	
Ambient temperature	<ul style="list-style-type: none"> • Min. -15 °C (5 °F) – no frost allowed • Max. (fsw = 1 or 4) 40 °C (104 °F); 50 °C (122 °F) if P_N and I_{2N} derated to 90% • Max. (fsw = 8) 40 °C (104 °F) if P_N and I_{2N} derated to 80% • Max. (fsw = 12) 30 °C (86 °F) if P_N and I_{2N} derated to 65% (to 50% for 600 V, R4 frame sizes, that is for ACQ550-U1-032A-6 ... ACQ550-U1-062A-6) 	-40...70 °C (-40...158 °F)
Relative humidity	5...95%, no condensation allowed	

Ambient environment requirements		
	Installation site	Storage and transportation in the protective package
Contamination levels (IEC 721-3-3)	<ul style="list-style-type: none"> No conductive dust allowed. The ACQ550 should be installed in clean air according to enclosure classification. Cooling air must be clean, free from corrosive materials and free from electrically conductive dust. Chemical gases: Class 3C2 Solid particles: Class 3S2 	Storage <ul style="list-style-type: none"> No conductive dust allowed. Chemical gases: Class 1C2 Solid particles: Class 1S2 Transportation <ul style="list-style-type: none"> No conductive dust allowed. Chemical gases: Class 2C2 Solid particles: Class 2S2

The following table lists the standard stress testing that the ACQ550 passes.

Stress tests		
	Without shipping package	Inside shipping package
Sinusoidal vibration	Mechanical conditions: In accordance with IEC 60721-3-3, Class 3M4 <ul style="list-style-type: none"> 2...9 Hz 3.0 mm (0.12 in) 9...200 Hz 10 m/s² (33 ft/s²) 	In accordance with ISTA 1A and 1B specifications.
Shock	Not allowed	In accordance with IEC 68-2-29: max. 100 m/s ² (330 ft/s ²), 11ms
Free fall	Not allowed	<ul style="list-style-type: none"> 76 cm (30 in), frame size R1 61 cm (24 in), frame size R2 46 cm (18 in), frame size R3 31 cm (12 in), frame size R4 25 cm (10 in), frame size R5 15 cm (6 in), frame size R6





Materials

Material specifications	
Drive enclosure	<ul style="list-style-type: none"> PC/ABS 2.5 mm, color NCS 1502-Y or NCS 7000-N Hot-dip zinc coated steel sheet 1.5...2 mm, thickness of coating 20 micrometers. If the surface is painted, the total thickness of the coating (zinc and paint) is 80...100 micrometers. Cast aluminium AlSi Extruded aluminium AlSi
Package	Corrugated board, expanded polystyrene, plywood, raw wood (heat dried). Package wrap consists of one or more of the following: PE-LD plastic wrap, PP or steel bands.

Material specifications	
Disposal	<p>The drive contains raw materials that should be recycled to preserve energy and natural resources. The package materials are environmentally compatible and recyclable. All metal parts can be recycled. The plastic parts can either be recycled or burned under controlled circumstances, according to local regulations. Most recyclable parts are marked with recycling marks.</p> <p>If recycling is not feasible, all parts excluding electrolytic capacitors and printed circuit boards can be landfilled. The DC capacitors contain electrolyte and, if the drive is not provided with the RoHS marking, the printed circuit boards contain lead, both of which are classified as hazardous waste within the EU. They must be removed and handled according to local regulations.</p> <p>For further information on environmental aspects and more detailed recycling instructions, please contact your local ABB distributor.</p>

Applicable standards

Drive compliance with the following standards is identified by the standard “marks” on the type designation label.

Mark	Applicable standards	
	EN 50178 (1997)	Electronic equipment for use in power installations
	IEC/EN 60204-1 (2005)	Safety of machinery. Electrical equipment of machines. Part 1: General requirements. <i>Provisions for compliance:</i> The final assembler of the machine is responsible for installing: <ul style="list-style-type: none"> • an emergency-stop device • a supply disconnecting device.
	IEC/EN 60529 (2004)	Degrees of protection provided by enclosures (IP code)
	IEC 60664-1 (2002)	Insulation coordination for equipment within low-voltage systems. Part 1: Principles, requirements and tests
	IEC/EN 61800-5-1 (2003)	Adjustable speed electrical power drive systems. Part 5-1: Safety requirements. Electrical, thermal and energy
	IEC/EN 61800-3 (2004)	Adjustable speed electrical power drive systems. Part 3: EMC requirements and specific test methods
	IEC/EN 61000-3-12	Electromagnetic compatibility (EMC). Part 3-12: Limits - Limits for harmonic currents produced by equipment connected to public low-voltage systems with input current > 16 A and = 75 A per phase
	IEC/EN 61800-3 (2004)	Adjustable speed electrical power drive systems. Part 3: EMC requirements and specific test methods
	UL 508C	UL Standard for Safety, Power Conversion Equipment, third edition
	C22.2 No. 14	CSA Standard for Industrial Control Equipment (for ACQ550-U1 drives only)

CE marking

 A CE mark is attached to the drive to verify that the drive follows the provisions of the European Low Voltage and EMC Directives.

Note: The 600 V ACQ550-U1 drives are not CE approved.

Compliance with the EMC Directive

The Directive defines the requirements for immunity and emissions of electrical equipment used within the European Union. The EMC product standard (IEC/EN 61800-3 [2004]) covers requirements stated for drives.

Compliance with IEC/EN 61800-3 (2004)

See page [301](#).

C-Tick marking

 The drive carries C-Tick marking.

C-Tick marking is required in Australia and New Zealand. A C-Tick mark is attached to the drive to verify compliance with the relevant standard (IEC 61800-3 (2004) – Adjustable speed electrical power drive systems – Part 3: EMC product standard including specific test methods), mandated by the Trans-Tasman Electromagnetic Compatibility Scheme.

The Trans-Tasman Electromagnetic Compatibility Scheme (EMCS) was introduced by the Australian Communication Authority (ACA) and the Radio Spectrum Management Group (RSM) of the New Zealand Ministry of Economic Development (NZMED) in November 2001. The aim of the scheme is to protect the radio frequency spectrum by introducing technical limits for emission from electrical/ electronic products.

Compliance with IEC/EN 61800-3 (2004)

See page [301](#).

UL/CSA markings



An UL mark is attached to ACQ550 drives to verify that the drive follows the provisions of UL 508C.



A CSA mark is attached to ACQ550-U1 type drives to verify that the drive follows the provisions of C22.2 NO. 14.

The ACQ550 is suitable for use in a circuit capable of delivering not more than 100 kA RMS symmetrical amperes, 600 V maximum. The ampere rating is based on tests done according to UL 508.

Branch circuit protection must be provided in accordance with local codes.

The ACQ550 has an electronic motor protection feature that complies with the requirements of UL 508C and, for ACQ550-U1, C22.2 No. 14. When this feature is selected and properly adjusted, additional overload protection is not required unless more than one motor is connected to the drive or unless additional protection is required by applicable safety regulations. See parameters 3005 (MOT THERM PROT) and 3006 (MOT THERM RATE).

The drives are to be used in a controlled environment. See section [Ambient conditions](#) on page [296](#) for specific limits.

Note: For open type enclosures, i.e. drives without the conduit box and/or cover for IP21 / UL type 1 drives, or without the conduit plate and/or hood for IP54 / UL type 12 drives, the drive must be mounted inside an enclosure in accordance with National Electric Code and local electrical codes.

Brake choppers, when applied with appropriately sized brake resistors, will allow the drive to dissipate regenerative energy (normally associated with quickly decelerating a motor). Frame sizes R1 and R2 have a built-in brake chopper as standard equipment. For frame sizes R3...R6, contact your ABB representative for appropriate parts. See section [Brake components](#) on page [285](#).

IEC/EN 61800-3 (2004) Definitions

EMC stands for **Electromagnetic Compatibility**. It is the ability of electrical/electronic equipment to operate without problems within an electromagnetic environment. Likewise, the equipment must not disturb or interfere with any other product or system within its locality.

First environment includes establishments connected to a low-voltage network which supplies buildings used for domestic purposes.

Second environment includes establishments connected to a network not directly supplying domestic premises.

Drive of category C2: drive of rated voltage less than 1000 V and intended to be installed and commissioned only by a professional when used in the first environment.

Note: A professional is a person or organisation having necessary skills in installing and/or commissioning power drive systems, including their EMC aspects.

Category C2 has the same EMC emission limits as the earlier class first environment restricted distribution. EMC standard IEC/EN 61800-3 does not any more restrict the distribution of the drive, but the using, installation and commissioning are defined.

Drive of category C3: drive of rated voltage less than 1000 V, intended for use in the second environment and not intended for use in the first environment.

Category C3 has the same EMC emission limits as the earlier class second environment unrestricted distribution.

Compliance with the IEC/EN 61800-3 (2004)

The immunity performance of the drive complies with the demands of IEC/EN 61800-3, category C2 (see page 301 for IEC/EN 61800-3 definitions). The emission limits of IEC/EN 61800-3 are complied with the provisions described below.

First environment (drives of category C2)

1. The internal EMC filter is connected.
2. The motor and control cables are selected as specified in this manual.
3. The drive is installed according to the instructions given in this manual.
4. The motor cable length does not exceed the allowed maximum length specified in section [Motor cable length for 400 V drives](#) on page 280 for the frame size and switching frequency in use.

WARNING! In a domestic environment, this product may cause radio interference, in which case supplementary mitigation measures may be required.

Second environment (drives of category C3)

1. The internal EMC filter is connected.
2. The motor and control cables are selected as specified in this manual.
3. The drive is installed according to the instructions given in this manual.

4. The motor cable length does not exceed the allowed maximum length specified in section [Motor cable length for 400 V drives](#) on page 280 for the frame size and switching frequency in use.

WARNING! A drive of category C3 is not intended to be used on a low-voltage public network which supplies domestic premises. Radio frequency interference is expected if the drive is used on such a network.

Note: It is not allowed to install a drive with the internal EMC filter connected on IT (ungrounded) systems. The supply network becomes connected to ground potential through the EMC filter capacitors, which may cause danger or damage the drive.

Note: It is not allowed to install a drive with the internal EMC filter connected to a corner grounded TN system as this would damage the drive.

Index

Numerics	
0xxxx register	
EFB function codes	200
EFB mapping	198
1xxxx register	
EFB function codes	201
EFB mapping	200
2-wire sensor/transmitter, connection example . .	65
3-wire macro	59
3-wire sensor/transmitter, connection example . .	65
3xxxx register	
EFB function codes	201
EFB mapping	201
4xxxx register	
EFB function codes	203
EFB mapping	201
A	
ABB	
document library	315
feedback on ABB manuals	315
product and service inquiries	315
product training	315
standard (default) macro	58
acceleration	
/deceleration, parameter group	116
at aux. stop (PFC), parameter	175
compensation, parameter	119
ramp select, parameter	116
ramp shape, parameter	116
ramp time (PFC), parameter	175
ramp zero select, parameter	117
time, parameter	116
activate (external PID), parameter	154
actual input (PID), parameters	150
actual max. (PID), parameters	150
actual min. (PID), parameters	150
actual values	
mapping, FBA, generic profile	249
scaling, EFB comm	191
scaling, FBA comm	236
scaling, FBA, ABB drives profile	247
scaling, FBA, generic profile	249
alarm	
codes	258
display enable, parameter	109
listing	258
words, data parameters	90
alternate macro	60
altitude	
derating	270
environment limit	296
shipping limit	296
ambient conditions	296
ambient temperature	
derating	270
environment limit	296
shipping limit	296
amplitude logging	
see load analyzer	
analog cable, requirements	290
analog I/O	
connections	24
specifications	24
analog input	
parameter group	100
BACnet object listing	220
data parameter	86
fault limit, parameters	126
filter, parameters	100
less than min. auto. reset, parameter	128
less than min., fault parameter	124
loss, fault codes	253
maximum, parameters	100
minimum, parameters	100
analog output	
parameter group	104
BACnet object listing	220
content max., parameters	104
content min., parameters	104
current max., parameters	104
current min., parameters	104
data content, parameters	104
data parameters	86
filter, parameters	104
analyzer, load	
see load analyzer	
application block output, data parameter	85
application macro, parameter	83
application macros	
see macros	
assistant (ACQ Control Panel)	
tasks	47
autochange	
interval, parameter	168
level, parameter	169
overview	169
starting order counter	169
automatic reset	
see reset, automatic	
auxiliary motor	
see motor, auxiliary	
B	
backup	
drive parameters	49

BACnet		comm (EFB)	
autobaud detection	224	actual value scaling	191
data link layer	225	actual values	190
mac id	225	analog output control, activate	189
max info frame property	225	comm fault response	189
MS/TP token counter	225	configuration	181
object, analog inputs	220	configure for loss of communication	193
object, analog outputs	220	control interface	178
object, analog values	221	diagnostics	192
object, binary inputs	217	drive control of functions, activate	185
object, binary outputs	217	fault code 28	193
object, binary values	218	fault code 31	193, 194
object, definitions	228	fault code 32	194
pics, statement	226	fault code 33	194
pics, summary	225	fault tracing parameters	192
services supported	225	fault, duplicate stations	193
support, matrix	228	fault, intermittent off-line	194
battery (ACQ Control Panel)	265	fault, no master station on line	193
baud rate (RS-232), parameter	158	fault, swapped wires	193
binary input		feedback from drive	190
BACnet object listing	217	feedback from drive, mailbox	190
binary output		input ref. sel., activate	186
BACnet object listing	217	installation	179
braking		mailbox, param. read/write	190
components	285	misc. drive control, activate	187
protection from overheated resistor	288	normal operation	192
resistor heat dissipation	288	overview	177
selecting brake choppers/resistors	285	PID control setpoint source, activate	189
wiring	288	planning	178
break point frequency, fault parameter	125	relay output control, activate	188
buffer overruns (count), parameter	158	start/stop control, activate	185
		termination	179
		communication	
C		see EFB (embedded fieldbus)	
cable requirements		see EFB, drive parameters	
control	289	see FBA (fieldbus adapter)	
grounding	275	see FBA, drive parameters	
input power	274	conduit kit	19
motor	282	config file	
capacitor		CPI firmware revision, parameter	157
reforming	265	fault code	254
replacement	265	id revision, parameter	157
category (IEC/EN 61800-3 definition)		revision, parameter	157
C2	301	connections	
C3	301	control	24
CB		diagram	24
see control board		EFB comm	179
CE marking	299	FBA module	232
chopper		X1	24
see braking		constant speed	
clock		see speed, constant	
see time & date	53	construction code	13
CO2 conversion factor		contamination levels	
see energy saving		environment limit	297
		shipping limit	297
		contrast, control panel	43
		control	
		connection specifications	289
		location, data parameter	85
		terminal specifications	290
		through I/O interface	39

control board			
overtemperature, fault code	255		
overtemperature, fault parameter	127		
temperature, data parameter	87		
control cable			
connections	24		
requirements	289		
control panel	47		
backup, drive parameters	49		
cable requirements	290		
changed parameters mode	48		
comm error, fault parameter	124		
contrast	43		
display bar-graph	132, 133		
display contrast	43		
display decimal point (form), parameters	132		
display max., parameters	133		
display min., parameters	133		
display process variables, parameter group	132		
display selection, parameters	132		
display units, parameters	133		
features	43		
i/o settings mode	55		
maintenance	265		
modes	44		
operating the drive	45		
parameter lock, parameter	106		
parameters mode	45		
pass code, parameter	106		
reference control, parameter	94		
signal max., parameters	132		
signal min., parameters	132		
soft keys	43		
start-up assistant mode	47		
status information	44		
time & date set	53		
control panel (ACQ)			
battery	265		
fault logger mode	49		
fault mode	251, 252		
parameter backup mode	49		
control word			
ABB drives, FBA, description	240		
EFB, description	205		
FBA	230		
FBA generic profile	248		
cooling			
air flow	291		
fan maintenance triggers	123		
heat loss	291		
space requirement	291		
corner grounded TN system	275		
warning about filters	6		
warning about screws at EM1, EM3	21		
warning about screws at F1, F2	22		
correction source (PID), parameter	155		
cover			
remove	17		
replace	32		
cover, top, see hood			
CRC errors (count), parameter	158		
crimp-on ring lugs	277		
critical speeds (avoiding)			
parameter group	120		
high, parameters	120		
low, parameters	120		
select, parameter	120		
C-Tick marking	299		
current			
at fault, history parameter	91		
data parameter	85		
max. limit, parameter	110		
measurement, fault code	254		
rating code	13		
D			
date			
see time & date	53		
DC			
brake time, parameter	114		
bus voltage, data parameter	85		
current ref., parameter	114		
magnetizing time, parameter	113		
overvoltage, fault code	252		
undervoltage, fault code	253		
voltage stabilizer, parameter	122		
deceleration			
parameter group	116		
at aux. start (PFC), parameter	175		
emergency time, parameter	117		
ramp select, parameter	116		
ramp shape, parameter	116		
ramp time (PFC), parameter	175		
ramp zero select, parameter	117		
time, parameter	116		
default values			
listing for macros	67		
listing for parameters	69		
derating			
adjustment example	270		
altitude	270		
single phase supply	270		
switching frequency	270		
temperature	270		
derivation time (PID), parameter	147		
derivation time, parameter	118		
device overtemperature, fault code	253		
diagnostics	251		
EFB comm	192		
FBA comm	237		
differences list, downloads	52		
digital cable requirements	290		
digital input			
at fault, history parameters	91		
connections	24		
specifications	25		
status, data parameter	86		
digital output			
connections	24		
specifications	289		
dimensions			
drive, mounting	293		
drive, outside	294		
DIP switches	21, 24		

fault			
functions, parameter group	124	FBA, drive parameters	157
history, parameter group	91	ext comm module parameter group	157
codes	252	command words, data parameters	89
comm failure (EFB)	189	config file CPI firmware revision, parameter	157
current at, history parameter	91	config file id revision, parameter	157
digital input status at, history parameter	91	config file revision, parameter	157
FBA comm	236	fault function, parameter	126
frequency at, history parameter	91	fault time, parameter	126
history	257	fieldbus appl. program revision, parameter	157
last, history parameter	91	fieldbus CPI firmware revision, parameter	157
listing	252	fieldbus parameter refresh, parameter	157
mode (ACQ Control Panel)	251, 252	fieldbus parameters	157
previous, history parameter	91	fieldbus status, parameter	157
reset	257	fieldbus type, parameter	157
reset select, parameter	106	protocol select, parameter	176
speed at, history parameter	91	relay output word, data parameter	86
status at, history parameter	91	status words, data parameters	89
time of, history parameters	91	values, data parameter	86
torque at, history parameter	91	feedback	
voltage at, history parameter	91	multiplier (PID), parameter	149
words, data parameters	90	on ABB manuals	315
fault code		select (PID), parameter	149
28 serial 1 err	193	field weakening point	279
fault display		fieldbus	
alarm	252	see EFB (embedded fieldbus)	
fault	251	see EFB, drive parameters	
fault names	252	see FBA (fieldbus adapter)	
fault logging (ACQ control panel)	49	see FBA, drive parameters	
FB actual signals, parameter group	89	fieldbus adapter	
FBA		see FBA	
protocol listing	229	see FBA, drive parameters	
FBA (fieldbus adapter)	229	fieldbus, embedded	
actual values	231	see EFB, drive parameters	
analog output control, activate	235	firmware	
comm fault response	236	version, parameter	131
configuration	233	first environment	
control word	230	(C2), compliance with IEC/EN 61800-3	301
control word, ABB drives	240	(C2), motor cable length	280
diagnostics	237	definition	301
drive feedback	236	flange mounting	16
fieldbus control, activate	233	floating network	
input reference sel., activate	234	see IT system	
installation	232	flux braking, parameter	121
PID control setpoint source, activate	236	flux optimization, parameter	121
planning	231	force trip, fault code	255
reference	231	frame errors (count), parameter	158
relay output control, activate	235	frame size	267
set-up	233	free fall, stress testing	297
start/stop /direction control, activate	233	frequency	
state diagram, ABB drives	243	at fault, history parameter	91
status word	231	max. limit, parameter	111
status word, ABB drives	241	min. limit, parameter	111
		motor, resolution	279
		motor, specification	279
		switching, parameter	122
		fuses	
		208...240 V drives	272
		380...480 V drives	272
		500...600 V drives	273

G

gain (PID), parameter	146
-----------------------	-----

- generic profile, FBA
 - actual value mapping 249
 - actual value scaling 249
 - overview 248
 - reference scaling 248
 - technical data 248
 - gland kit 19
 - ground
 - cable/wire requirements 275
 - fault protection 282
- H**
- hand-auto macro 62
 - harmonics 299
 - heat loss 291
 - hood (IP54 / UL type 12) 17, 32
- I**
- I/O, control through 39
 - id run
 - fail, fault code 253
 - parameter 84
 - performing 40
 - identification magnetization 84
 - IEC ratings
 - see ratings
 - impedance grounded network
 - see IT system
 - incompatible software, fault code 255
 - information on the Internet 315
 - information, parameter group 131
 - input power
 - cable/wire requirements 274
 - disconnecting device (disconnecting means) 271
 - specifications 271
 - input power connection
 - IT system 276
 - lugs for R6 277
 - terminal size 276
 - torque 276
 - installation
 - check list 31
 - compatibility 14
 - environment 14
 - flow chart 11
 - location 15
 - mounting drive 18
 - preparation 12
 - procedures 11
 - tools 14
 - wiring overview 19
 - insulation check 26
 - integration time (PID), parameter 147
 - integration time, parameter 118
 - interlocks, parameter 170
 - internal setpoint (PID), parameter 149
 - Internet, information on 315
 - IR compensation
 - frequency, parameter 121
 - parameters 121
 - voltage, parameter 121
 - isolation, between AC power source and drive . 271
 - IT system
 - connections 276
 - warning about filters 6, 284
 - warning about screws at EM1, EM3. 21
 - warning about screws at F1, F2 22
- J**
- jogging activation, parameter 93
- K**
- keypad
 - see control panel
 - keypad reference select, parameter 94
 - kWh
 - counter, data parameter 85
- L**
- label
 - serial number 12
 - type designation 12
 - language, parameter 83
 - LED
 - on ACQ Control Panel 251, 252
 - on drive body 21, 251, 252
 - library, document 315
 - limits, parameter group 110
 - load analyzer
 - parameter group 161
 - amplitude logger 1, distribution 162
 - amplitude logger 2 signal base value, par... 161
 - amplitude logger 2 signal, parameter 161
 - amplitude logger 2, distribution 162
 - loggers reset date 162
 - loggers reset time 162
 - loggers reset, parameter 161
 - peak value logger filter time, parameter 161
 - peak value logger signal, parameter 161
 - peak value logger, current at peak value . . . 162
 - peak value logger, detected peak value. . . . 161
 - peak value logger, frequency at peak value. 162
 - peak value logger, peak value date 161
 - peak value logger, peak value time 161
 - peak value logger, voltage at peak value. . . 162
 - load curve, see user load curve
 - load frequency, see user load curve
 - load torque, see user load curve
 - loading package version, parameter 131
 - lock
 - control panel access, IP54 32
 - parameters 106
 - loggers
 - see load analyzer
 - low frequency (PFC), parameters 166
 - lugs
 - for R6 power cables 277
 - ring, crimp-on 277
 - terminal, screw-on 278

M

macros			
3-wire	59		
ABB standard (default)	58		
alternate	60		
hand-auto	62		
motor potentiometer	61		
PFC	64		
PID control	63		
user parameter sets	66		
parameter default values	67		
parameters not changed	57		
magnetization, identification	84		
mailbox, EFB comm	190		
mains			
see input power			
maintenance			
capacitors	265		
control panel	265		
heat sink	261		
internal enclosure fan	264		
intervals	261		
main fan	262		
triggers, parameter group	123		
manuals			
list of ACS550 manuals	2		
providing feedback	315		
mapping			
actual value, FBA, generic profile	249		
EFB modbus	198		
materials	297		
maximum			
frequency, parameter	111		
torque limit, parameters	112		
torque select, parameter	111		
minimum			
frequency, parameter	111		
torque limit, parameters	111		
torque select, parameter	111		
modbus			
EFB addressing, convention	198		
EFB coils	198		
EFB discrete inputs	200		
EFB holding registers	201		
EFB input registers	201		
EFB mapping details	198		
EFB mapping summary	198		
EFB supported features	197		
EFB technical data	197		
motor			
checking insulation	26		
compatibility	14		
id run, parameter	84		
load curve break point frequency	125		
load curve max., fault parameter	125		
load curve zero speed load	125		
maintenance triggers	123		
nominal current, parameter	83		
nominal frequency, parameter	83		
nominal power, parameter	84		
nominal speed, parameter	84		
nominal voltage, parameter	83		
phase, fault code	255		
requirements	14		
stall, fault code	254		
thermal protection	281		
motor cable			
checking insulation	26		
length	279		
max. length	279		
requirements	282		
requirements, EMC	283		
motor connection			
lugs for R6	277		
terminal size	276		
torque	276		
motor control			
parameter group	121		
control mode, parameter	83		
IR compensation, parameters	121		
motor potentiometer macro	61		
motor temperature			
measure, parameter group	135		
alarm limit, parameter	136		
data parameter	87		
fault limit, parameter	137		
overtemperature, fault code	253		
sensor selection, parameter	136		
sensor type, parameter	136		
thermal protection	281		
thermal protection, fault parameter	124		
thermal stress, data parameter	87		
thermal time, fault parameter	125		
motor, auxiliary			
aux start order, parameter	175		
aux. start delay (PFC), parameter	166		
aux. stop delay (PFC), parameter	166		
number of aux., parameter	167		
motors			
several	269, 279		
mounting			
dimensions	293		
flange	16		
template	16		
multimotor systems	269, 279		
MWh			
counter, data parameter	87		
power consumption, maintenance trigger	123		

N

NEMA ratings
see ratings

setpoint minimum (PID), parameter	149	start	
setpoint select (PID), parameter	148	parameter group	113
shock, stress testing	297	aux. motor (PFC), parameters	165
short circuit, fault code	253	aux. motor delay	166
single phase supply		control, EFB comm.	185
connection	19	control, FBA comm.	233
derating	270	DC magnetizing time, parameter	113
sleep selection (PID), parameter	150	delay (PFC), parameter	174
slip compensation ratio, parameter	122	delay, parameter	115
soft keys, control panel	43	frequency (PFC), parameters	165
specifications		function, parameter	113
control connections	289	inhibit, parameter	114
input power	271	select enable source, parameter	108
mains	271	torque boost current, parameter	114
speed		start mode	
and direction (signed), data parameter	85	automatic	113
at fault, history parameter	91	automatic torque boost	113
data parameter	85	DC magnetizing	113
max. limit, parameter	110	flying start	113
min. limit, parameter	110	start/stop	
speed control		parameter group	113
parameter group	118	start/stop/dir, parameter group	92
acceleration compensation, parameter	119	starting order counter	169
automatic tuning, parameter	118, 119	start-up	
derivation time, parameter	118	data, parameter group	83
integration time, parameter	118	guided, ACQ Control Panel	33
proportional gain, parameter	118	limited, ACQ Control Panel	35
vector:speed mode	83	state diagram	
speed, constant		comm (EFB)	213
parameter group	97	comm, ABB drives	243
digital input selection parameter	97	station id (RS-232), parameter	158
parameters	98	status at fault, history parameter	91
stall		status word	
frequency, fault parameter	126	ABB drives, FBA, description	241
function, fault parameter	126	EFB comm, definition	208
region	126	FBA	231
time, fault parameter	126	FBA generic profile	248
standards	299	stop	
C22.2 No. 14	299	parameter group	113
CE marking	299	aux. motor (PFC), parameters	166
CSA marking	300	aux. motor delay	166
C-Tick marking	299	DC brake time, parameter	114
EN 50178	299	DC current control, parameter	113
IEC 60664-1	299	DC current ref., parameter	114
IEC/EN 60204-1	299	emergency devices	273
IEC/EN 60529	299	emergency select, parameter	114
IEC/EN 61000-3-12	299	flux braking, parameter	121
IEC/EN 61800-3	299	function, parameter	113
IEC/EN 61800-5-1	299	stress tests	297
UL 508C	299	supervision	
UL marking	300	parameter group	129
		parameter low limit, parameters	129
		parameter selection, parameters	129
		supply phase, fault code	254
		switching frequency	279
		control, parameter	122
		derating	270
		parameter	122
		symmetrically grounded network	
		see corner grounded TN system	
		symmetrically grounded TN system	275
		system controls, parameter group	106

T	
temperature derating	270
template, mounting	16
terminal lugs	278
terminals	
control, description	24
control, specifications	290
location diagram, R1...R4	21
location diagram, R5/R6	22
termination	179
test date, parameter	131
thermal fail, fault code	254
three-wire sensor/transmitter, connection example	65
time & date	53
timed functions	
parameter group	138
autochange, parameter	175
booster, parameter	140
enable, parameter	139
source, parameter	140
speed control.	99
start time, parameter	139
stop time, parameter	139
timed mode, parameter	99
TN-S system	275
tools	14
top cover, see hood	
torque	
at fault, history parameter	91
boost current, parameter	114
data parameter	85
max. limit select, parameter	111
max. limit, parameter	112
min. limit select, parameter	111
min. limit, parameters	111
torque control	
vector:torque mode	83
training	315
trim	
mode (PID), parameter	154
scale (PID), parameter	154
two-wire sensor/transmitter, connection example	65
type code	
see type designation	
type designation	12, 13
U	
U/f ratio, parameter	121
UL/CSA markings	300
underload curve	
see user load curve	
undervoltage	
automatic reset, parameter	128
control enable, parameter	110
ungrounded network	
see IT system	
units (PID), parameter	147
unknown drive type, fault code	255
unpacking drive	12
unsymmetrically grounded networks	
see corner grounded TN system	
user load curve	
parameter group	142
fault code	255
frequency, parameters	142, 143
function, parameter	142
mode, parameter	142
time, parameter	142
torque, parameters	142, 143
user parameter set	66
change control, parameter	107
download	51
V	
vector:	
speed mode	83
version	
firmware, parameter	131
loading package, parameter	131
parameter table, parameter	131
vibration, stress testing	297
voltage	
at fault, history parameter	91
rating code	13
voltage/frequency ratio, parameter	121
W	
wake-up	
delay (PID), parameter	151
deviation (PID), parameter	151
warning	
automatic start up	6
dangerous voltages	5
disconnecting device (disconnecting means)	6
ELV (Extra Low Voltage)	25
EM1, EM3, F1 and F2 screws	6
filter on corner grounded TN system	6
filter on IT system	6
high temperatures	6
listing	5
not field repairable	6
parallel control connections	5
qualified installer	5
weight	295
wiring	
control	24
fault, parameter	127
installation	26
installation steps, IP21/cables	27
installation steps, IP21/conduit	28
installation steps, IP54/cables	29
installation steps, IP54/conduit	30
overview	19
requirements, general	19
XYZ	
zero speed	
delay, parameter	115
load, fault parameter	125

Further information

Product and service inquiries

Address any inquiries about the product to your local ABB representative, quoting the type designation and serial number of the unit in question. A listing of ABB sales, support and service contacts can be found by navigating to www.abb.com/drives and selecting *Sales, Support and Service Network*.

Product training

For information on ABB product training, navigate to www.abb.com/drives and select *Training courses*.

Providing feedback on ABB Drives manuals

Your comments on our manuals are welcome. Go to www.abb.com/drives and select *Document Library – Manuals feedback form (LV AC drives)*.

Document library on the Internet

You can find manuals and other product documents in PDF format on the Internet. Go to www.abb.com/drives and select *Document Library*. You can browse the library or enter selection criteria, for example a document code, in the search field.



3AJA0000145616 Rev C
EFFECTIVE: 3-15-2017

ABB Inc.

Automation Technologies
Drives & Motors
16250 West Glendale Drive
New Berlin, WI 53151
USA

Telephone +1 262 785-3200
Tech Support +1 800 752-0696
Fax +1 262 780-5135