

---

# ***Bus Conversion Unit***

**10.5" & 12.1" QuickPanel Ethernet Series**

**Installation Guide**

The following are trademarks of Total Control Products, Inc.: *QUICKPANEL*<sup>™</sup> and *QUICKPANEL jr.*<sup>™</sup>

Information in this document is subject to change without notice and does not represent a commitment on the part of Total Control Products, Inc. The software described in this document is provided under a license agreement. The software may be used or copied only under the terms of the agreement. Only one copy of the software may be made for a backup.

Total Control Products, Inc. makes no warranty, either expressed or implied, including but not limited to any implied warranties of merchantability or fitness for a particular purpose, regarding these materials and makes such materials available solely on an "as-is" basis.

In no event shall Total Control Products, Inc. be liable to anyone for special, collateral, incidental, or consequential damages in connection with or arising out of purchase or use of these materials. The sole and exclusive liability to Total Control Products, Inc., regardless of the form of action, shall not exceed the purchase price of the materials described herein.

No part of this manual may be reproduced or transmitted in any form or by any means, electronic or mechanical, including photocopying, recording, or information storage and retrieval systems, for any purpose other than the purchaser's personal use, without the express written permission of Total Control Products, Inc.

Copyright 1995, Total Control Products, Inc. All rights reserved.

**Total Control Products, Inc.**  
**2700 Oxford Tower, 10235-101 Street, Edmonton, Alberta T5J 3G1, CANADA**  
**Phone (780) 420-2000, Fax (780) 420-2049**

# **Bus Conversion Unit (QPI-PSL-201) (for 10.5" & 12.1" QP-Ethernet Series Units)**

Thank you for purchasing Total Control Products' Bus Conversion Unit (QPI-PSL-201), hereafter referred to as the "Unit". This Unit allows the attachment of QPI-xxx-20x series expansion units to 10.5" and 12.1" QP-Ethernet Series units. This manual provides an overview of this Unit, as well as procedures to follow when installing it in the User's system. Be sure to read all this important information carefully prior to using this Unit.

*This product is CE marked and UL/c-UL(CSA) compliant. Therefore, be aware that when it is used in combination with a product that is not CE marked and UL/c-UL(CSA) compliant, this product will lose its conformance with these standards.*

# Safety Precautions

This guide includes information that must be followed to ensure the correct and safe use of this product. Be sure to read both this guide and any related manuals to thoroughly understand the correct operation and functions of both the Bus Conversion Unit and the 10.5" and 12.1" QP-Ethernet Series units.

## ■ Usage of Safety Icons

Throughout this manual the following icons are shown near procedures requiring special attention to safety. The information given below these icons contains essential safety information.

The following examples explain the meaning of each safety icon:



**WARNING**

Indicates situations where severe bodily injury, death or major machine damage can occur.



**CAUTION**

Indicates situations where slight bodily injury or machine damage can occur.



## **WARNINGS**

- When attaching this unit to a 10.5" or 12.1" QP-Ethernet Series unit, make sure that the QP-Ethernet's power cord is not connected to the main power (constant), to prevent an electric shock.
- Do not modify this Unit in any way, since an electric shock or fire may occur.
- Do not use this Unit in areas where flammable gas is present, since an explosion may occur.
- Do not allow water, liquid or metallic objects to enter into the Unit, since they can cause either a malfunction or an electric shock.

### **To prevent this unit from malfunctioning :**

- Be sure the Unit is operated in an environment that is within the unit's designated temperature range.
- Do not operate or store this unit in an environment where it will be exposed to high temperatures.
- Do not operate or store this unit in an environment where it will be exposed to direct sunlight or excessive amounts of dust.
- Since this unit is a precision instrument, do not install it where strong impacts or vibration will occur.
- Do not operate or store this unit in an environment where it may be exposed to chemical vapors or fumes.

## UL/c-UL (CSA) Application Notes

The QPI-PSL-201 (Model #2980020-02) is a UL/c-UL listed product. (UL file No.E182139)

This unit conforms as a product to the following standards:

- **UL508**

Industrial Control Equipment

- **UL1604**

Electrical Equipment for use in Class I and II, Division 2, and Class III Hazardous (Classified) Locations.

- **CAN/CSA-C22.2, Nos. 142, and 213-M1987**

Standard for Safety of Information Technology Equipment, including Electrical Business Equipment

**QPI-PSL-201 (UL Registration Model #2980020-02)**

### **UL1604 Conditions of Acceptability and Handling Cautions:**

1. Power, input and output (I/O) wiring must be in accordance with Class I, Division 2 wiring methods - Article 501- 4(b) of the National Electrical Code, NFPA 70 within the United States, and in accordance with Section 18-152 of the Canadian Electrical Code for units installed within Canada.
2. Suitable for use in Class I, Division 2, Groups A, B, C and D, Hazardous Locations.
3. WARNING: Explosion hazard - substitution of components may impair suitability for Class I, Division 2.
4. WARNING: Explosion hazard - when in hazardous locations, turn power OFF before replacing or wiring modules.
5. WARNING: Explosion hazard - do not disconnect equipment unless power has been switched OFF, or the area is known to be non-hazardous.

## CE Marking Notes

The QPI-PSL-201 is a CE marked <sup>\*1</sup> product that conforms to EMC directives EN55011 Class A and EN61000-6-2.

*\*1 For detailed CE marking information, please contact your local distributor.*

# Package Contents

The following items are included in the Unit's package. Prior to using the Unit, be sure to confirm that all the items shown below are present.

■ **Bus Conversion Unit  
( QPI-PSL-201 )**

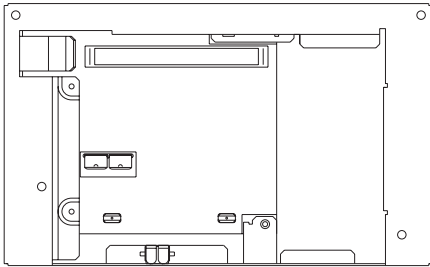

■ **Bus Conversion Unit  
Installation Guide ( 1 )  
( this document )**

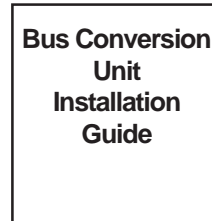

■ **Attachment Screws ( 4 )**

This unit has been carefully packed with special attention to quality. However, should you find anything damaged or missing, please contact your local distributor immediately.

## 1 Dimensions

The Unit's external dimensions are given below.

Unit: mm [in.]

Top

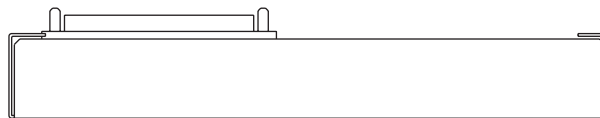

Right Side

Front

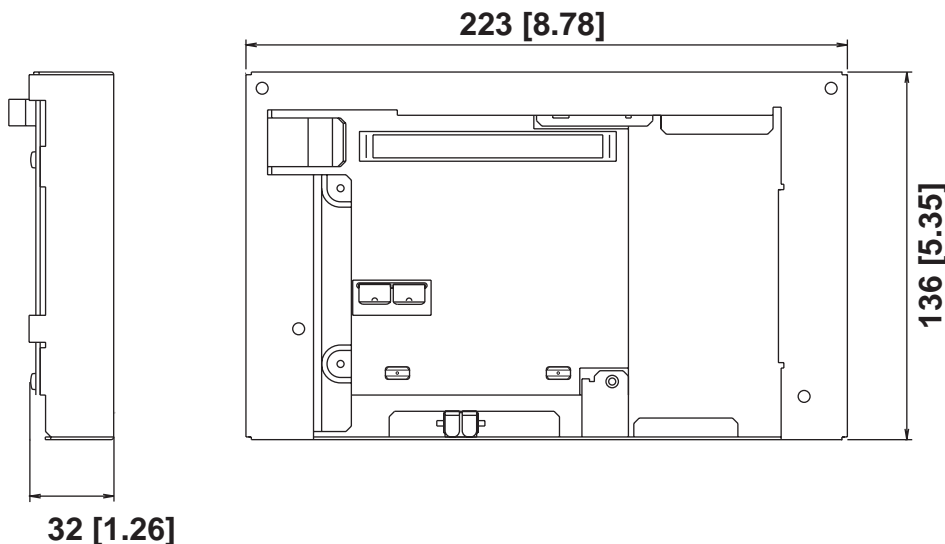

The figures below show the Bus Conversion Unit and an expansion unit attached to a 10.5" or 12.1" QP-Ethernet Series unit.

**Unit: mm [in.]**

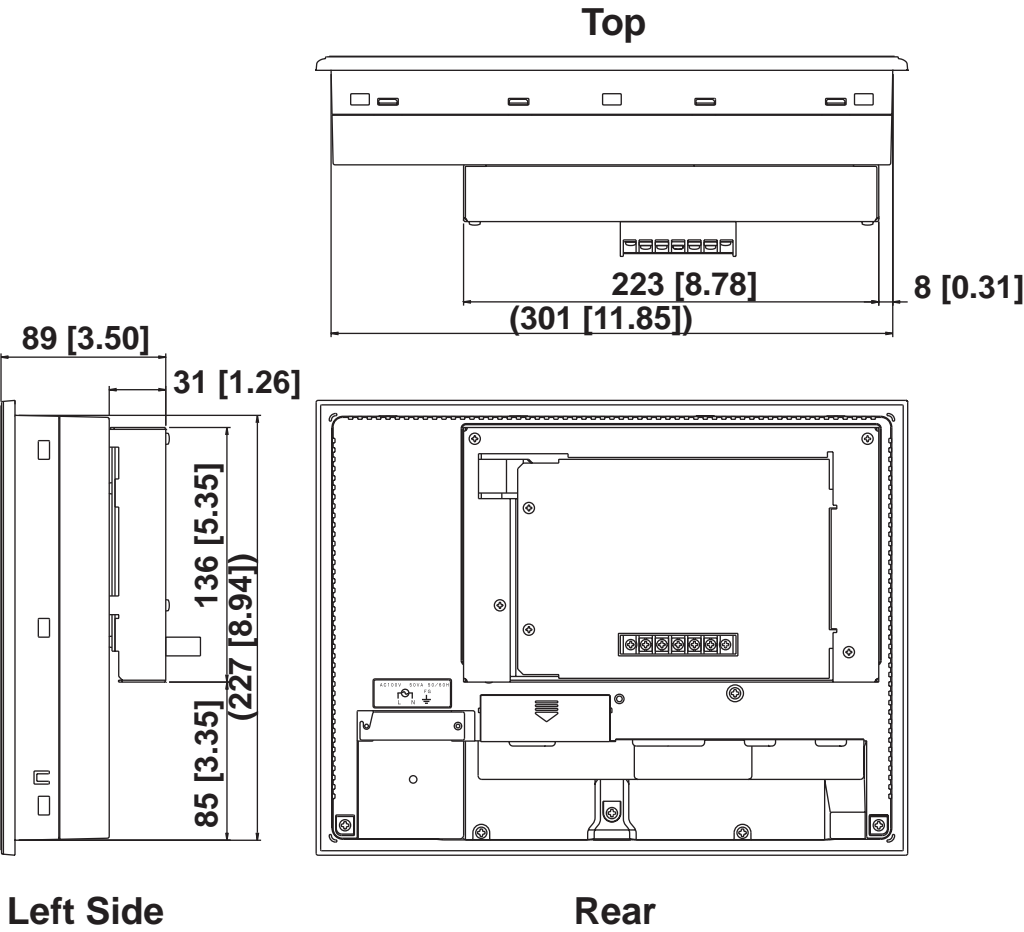

## 2 Part Name and Function

The Unit's part name and its function are explained below.

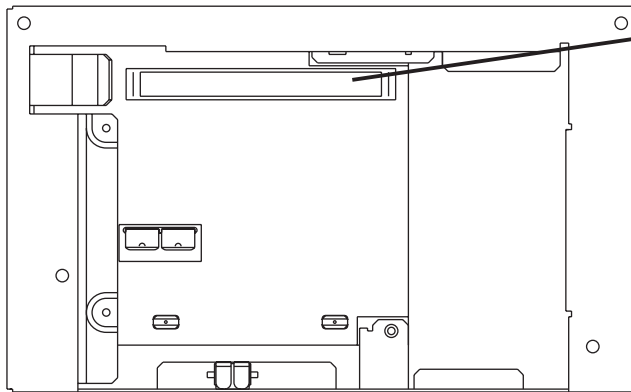

### Expansion Bus Connector

Used to connect QPI-xxx-20x series expansion units.

## 3 General Specifications

### ■ Environmental

Operating Temperature	0 °C to 50 °C
Storage Temperature	-20 °C to +60 °C
Humidity	10%RH to 90%RH (no condensation)
Vibration Resistance	based on JIS B 3501, IEC61131-2 (intermittent vibration) 10Hz to 57Hz 0.075mm 57Hz to 150Hz 9.8m/s <sup>2</sup> (continuous vibration) 10Hz to 57Hz 0.035mm 57Hz to 150Hz 4.9m/s <sup>2</sup> X, Y, and Z directions for 10 times each (80min.)
Corrosive Gas	Free of corrosive gas

### ■ Structural

External Dimensions	W223 [8.78] x H136 [5.35] x D32 [1.26] mm [in.] (Main unit only - excluding projections)
Weight	approx. 500g (1.10lb.)

## 4 Installation

Use the following procedures to install the Bus Conversion Unit in a QP-Ethernet Series unit.

### WARNINGS

Prior to installing this Unit:

- When attaching this unit to the QP-Ethernet Series units, make sure that the QP-Ethernet's power cord is not plugged in to the main power (constant), to prevent an electric shock.
- Be careful not to touch the surface of this unit's printed circuit board and be sure to wear cotton gloves.

1. Disconnect the QP-Ethernet Series power cord from the power supply.

2. Remove the three (3) Expansion Slot covers on the rear of the QP-Ethernet Series unit.

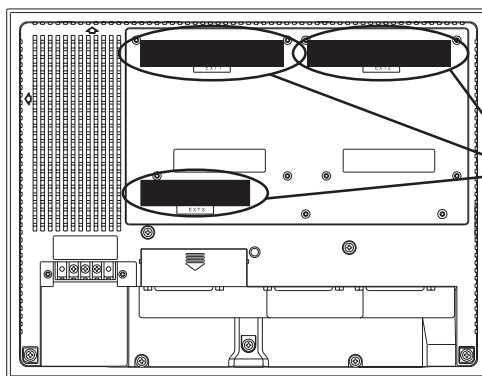

**Expansion  
Slot covers**

### CAUTIONS

- Do not touch the "copper spring" or the copper spring's contact. Be sure to wear gloves when installing this unit.

**Rear of Bus Conversion Unit**

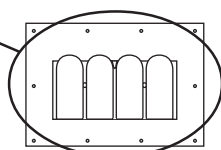
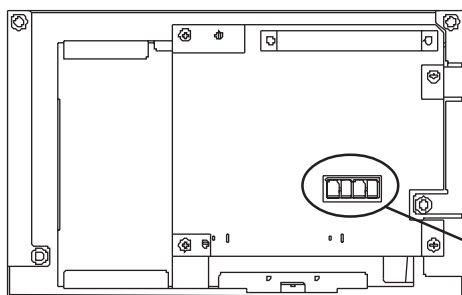

**Copper Spring**

**Rear of QP**

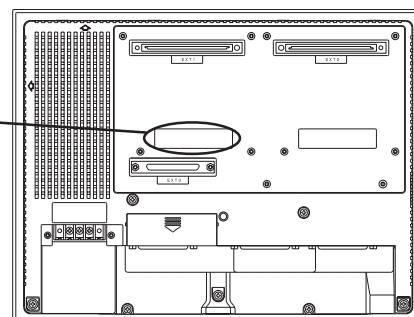

- Do not remove this Unit from the QP-Ethernet unless absolutely necessary. Excessive attachment and removal can lead to the Unit's premature breakdown or malfunction.

3. Align the Expansion Bus Connector over the QP-Ethernet Series unit's Rear Face Expansion Unit I/F. Then, press the Unit down so that the two unit's connect.

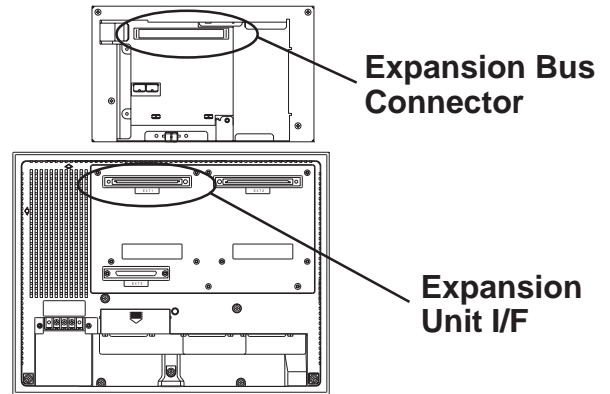

4. After the two connectors are securely attached, insert the four (4) attachment screws into the four (4) attachment screw holes and tighten the screws. Be sure that no gaps remain between the QP-Ethernet Series unit and the Unit.

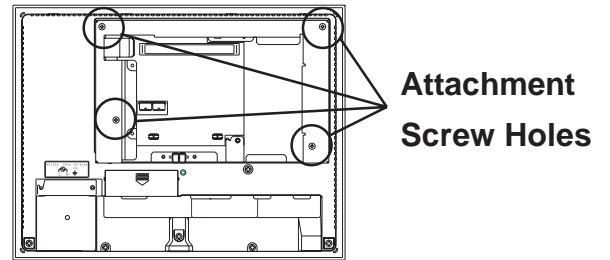

*A torque of only 0.5 to 0.6 N•m is required to tighten an attachment screw. Be careful not to use too much force, since it may damage the QP-Ethernet unit.*

5. Insert the expansion unit Attachment Tabs into the QP-Ethernet unit Attachment Slots. Be sure to install the expansion unit so that its smooth metal surface faces outward.

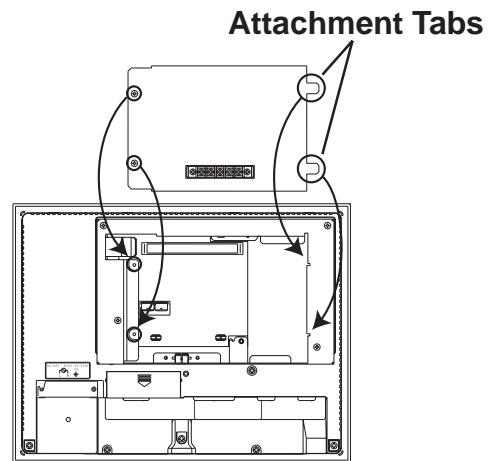

**Reference** Expansion Unit Users Manual

6. Attach the expansion unit to the Bus Conversion unit and tighten the two (2) expansion unit attachment screws (included with unit).

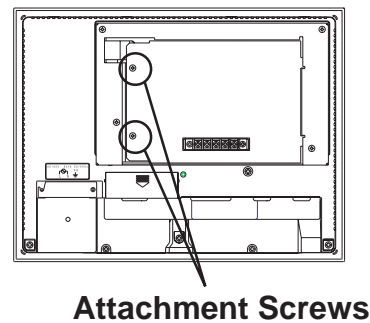

### Note

Please be aware that Total Control Products shall not be held liable by the user for any damages, losses, or third party claims arising from the uses of this product.