

F-Series

CIRCUIT BREAKER

The F-Series hydraulic-magnetic high amperage circuit breakers are designed to handle high current applications in extremely hot and/or cold locations. Due to its time-proven hydraulic-magnetic design, the F-Series load sensing mechanism is insensitive to changes in ambient or enclosure temperature, providing a consistent trip point over temperatures ranging from -40°C to +85°C. Additionally, the F-Series circuit breakers come with a choice of overload time delays, making them ideal for critical applications having inductive loads.

Further, the F-Series breakers are available up to 700A and an optional 25 millivolt metering shunt construction provides a safe method for monitoring current flowing through the breaker by simply connecting a meter with light gauge wire to the appropriate terminals located on the shunt housing at the rear of the breaker. Applications can be customized by measuring and displaying percentage of current, watts or safe/danger zones.

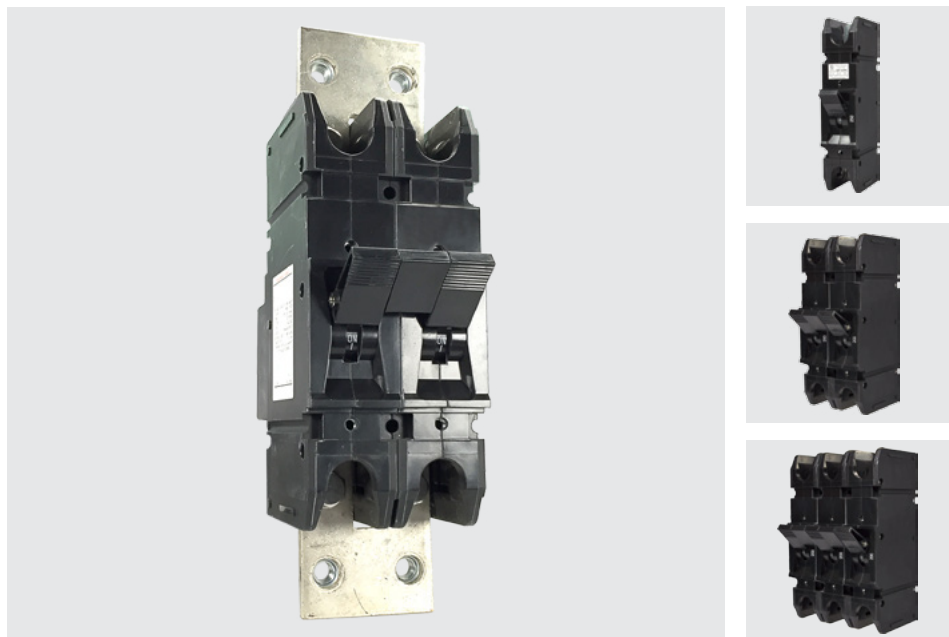

Product Highlights:

- ♦ AC ratings to UL 489
- ♦ DC voltage ratings up to 700A with metering shunt section
- ♦ Consistent trip point over temperatures ranging from -40°C to +85°C
- ♦ Optional 25 millivolt metering shunt construction

Typical Applications:

- ♦ Ideal for applications under extreme temperatures
- ♦ Higher Amperage Applications
- ♦ Battery Disconnect Systems
- ♦ Solar Power Systems
- ♦ Military



Electrical

Maximum Voltage 125VDC, 277VAC
 Current Ratings Standard current coils: 100, 125, 150, 175, 225, 250 amps. 300, 350, 400, 500, 600, 700 amps available as parallel pole construction.

Auxiliary Switch Rating SPDT; 10.1 Amps @ 250VAC, 1.0 Amps @ 65VDC, 0.5 Amps @ 80VDC 0.1 Amps @ 125VAC (with gold contacts).

Insulation Resistance Minimum: 100 Megohms at 500 VDC

Dielectric Strength 1960 VAC, 50/60 Hz for one minute between all electrically isolated terminals, except 2500 VAC for one minute between alarm/aux. switch and main terminals with contacts in open and closed position. F-Series circuit breakers comply with the 8mm spacing & 3750VAC 50/60 Hz dielectric requirements from hazardous voltage to operator accessible surfaces, between adjacent poles and from main circuits to auxiliary circuits per Publications EN 60950 and VDE 0805.

Resistance, Impedance Values from Line to Load Terminal - based on Series Trip Circuit Breaker.

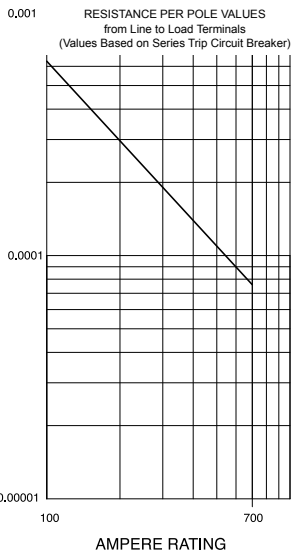

CURRENT (AMPS)	TOLERANCE (%)
100 - 700	50

Mechanical

Endurance 4000 ON-OFF operations with rated Current & Voltage & 4000 operations with no load (8000 operations total) @ 5 per minute. Parallel Pole construction: 1000 operations with rated Current and Voltage @ 5 per minute.

Trip Free All F-Series Circuit Breakers will trip on overload, even when the actuator is forcibly held in the ON position.

Trip Indication The operating actuator moves positively to the OFF position when an overload causes the circuit breaker to trip.

Physical

Number of Poles 1 - 3 Poles Note: Ratings over 250 Amps only available with parallel pole.

Internal Circuit Config. Series (with or without auxiliary switch), Switch Only (with or without auxiliary switch).

Available Accessories Factory installed: DC Current Metering Shunt (25 mV @Ir)

Weight Varies depending on construction. Consult factory.

Standard Colors Housing - Black; Actuator- Black or White with contrasting ON-OFF legend.

Environmental

Designed and tested in accordance with requirements of specification MIL-PRF-55629 & MIL-STD-202 as follows:

Shock Withstands 100 Gs, 6ms, sawtooth while carrying rated current per Method 213, Test Condition "I". Instantaneous and ultra-short curves tested @ 90% of rated current.

Vibration Withstands 0.060" excursion from 10-55 Hz, and 10 Gs 55-500 Hz, at rated current per Method 204C, Test Condition A. Instantaneous and ultrashort curves tested at 90% of rated current.

Moisture Resistance Method 106D; ten 24-hour cycles @ + 25°C to +65°C, 80-98% RH.56 days @ +85°C, 85% RH.

Salt Spray Method 101, Condition A (90-95% RH @ 5% NaCl Solution, 96 hrs).

Thermal Shock Method 107D, Condition A (Five cycles @ -55°C to +25°C to +85°C to +25°C).

Operating Temperature -40° C to +85° C

*Manufacturer reserves the right to change product specification without prior notice.

Electrical Tables

Table A: Lists UL Listed (489) and CSA Certified (C22.2 N0. 5.1-M) configurations and performance capabilities as a Molded Case Circuit Breaker

F SERIES TABLE A : UL489 LISTED BRANCH CIRCUIT BREAKERS						
CIRCUIT CONFIGURATION	VOLTAGE			CURRENT RATING	INTERRUPTING CAPACITY (AMPS)	
	MAX RATING	FREQUENCY	PHASE		FULL LOAD AMPS	UL / CSA
				1 - 3 POLES		1 or 2 POLES
SERIES	125	DC	---	50 - 250	50,000	25,000
	120 / 240 ¹	50 / 60	1	100 - 250	10,000	---
	277	50 / 60	1	100 - 250	10,000	---
	208Y / 120	50 / 60	3	100 - 250	10,000	---

Notes:

1 120/240V rating available in 2 or 3 poles. In a 3 pole construction the center pole is Neutral.

2 TUV constructions are not available with AC ratings and 150-250 amp ratings only.

Table B: Lists UL Listed configurations and performance capabilities as Circuit Breakers for use in Communications Equipment (Guide DITT, File E189195), under UL489A

F-SERIES TABLE B : UL489 LISTED BRANCH CIRCUIT BREAKERS				
CIRCUIT CONFIGURATION	VOLTAGE		CURRENT RATING	INTERRUPTING CAPACITY (AMPS)
	MAX. RATING	FREQUENCY		
SERIES	125	DC	251 - 700	50,000

Agency Certifications

UL Listed

UL 489



Circuit Breakers , Molded Case (Guide DIVQ, File E129899) Complies with the requirements of the CSA Standard for Molded Case Circuit Breakers,

CANCSA- C22.2 No. 5.1 –M

Circuit Breakers for Use in Communications Equipment (Guide DITT, File E189195)

TUV Certified



IEC 60947-2

Low Voltage Switchgear and Control Gear under TUV License No. R72031058

UL 489A



Circuit & Terminal Diagrams: in. [mm]

F SERIES NON-PARALLEL POLE CONSTRUCTION:

CIRCUIT BREAKER PROFILE	CIRCUIT SCHEMATIC		CIRCUIT CODE	AUX. SWITCH CODE	CIRCUIT SCHEMATIC		CIRCUIT CODE	AUX. SWITCH CODE
	ANSI	IEC			ANSI	IEC		
<p>SERIES TRIP (2 TERM.S.)</p>			A	0			BC	0
<p>SERIES TRIP W/AUX. SWITCH (5 TERM.S.)</p>			A	2 3 4 5 9			BC	2 3 4 5 9

TERMINAL DETAILS BACK CONNECT

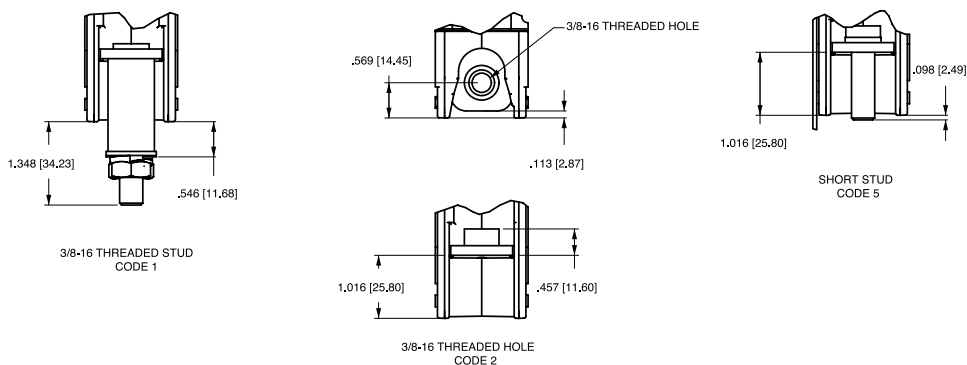

FRONT CONNECT

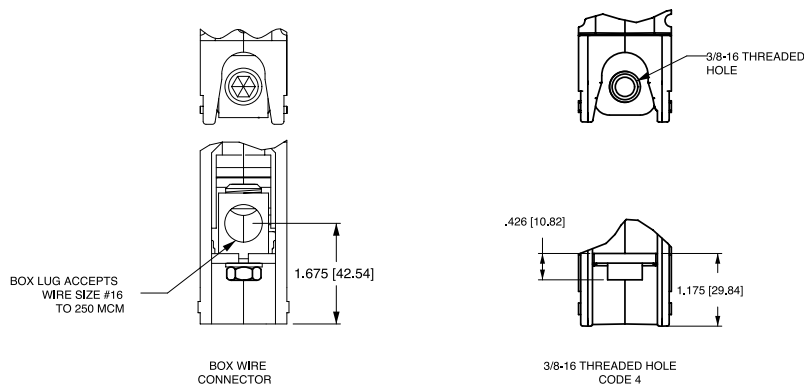

Notes:

- All dimensions are in inches [millimeters].
- Tolerance $\pm .020$ [.51] unless otherwise specified.

Circuit & Terminal Diagrams: in. [mm]

F-SERIES PARALLEL POLE CONSTRUCTION:

CIRCUIT BREAKER PROFILE	CIRCUIT SCHEMATIC		CIRCUIT CODE	AUX SWITCH CODE	CIRCUIT SCHEMATIC		CIRCUIT CODE	AUX SWITCH CODE
	ANSI	IEC			ANSI	IEC		
<p>SERIES TRIP (2 TERMS.)</p>	<p>SWITCH ONLY (NO COIL)</p>		A	0	<p>SERIES TRIP</p>		BC	0
<p>SERIES TRIP W/AUX. SWITCH (5 TERMS.)</p> <p>1.172 [29.76] TYP .335 [8.50] 1.273 [32.33] .480 [12.19] TYP 3.599 [91.41] 8.899 [226.03]</p>	<p>SWITCH ONLY (NO COIL) WITH ALARM OR AUX. SWITCH</p>		A	B	<p>SERIES TRIP WITH ALARM OR AUX. SWITCH</p>		BC	B
<p>SERIES TRIP W/METERING SHUNT (4 TERMS.)</p> <p>1.273 [32.33] (FOR 100-225 AMPS DIM = 2.000) 1.440 [36.57] 3.119 [79.22]</p>	<p>SWITCH ONLY (NO COIL) WITH METERING SHUNT</p>		N	0	<p>SERIES TRIP CURRENT COIL, WITH METERING SHUNT</p>		M	0
<p>RELAY TRIP (4 TERMS.)</p>	<p>SWITCH ONLY WITH ALARM OR AUX. SWITCH AND METERING SHUNT</p>		N	A	<p>SERIES TRIP WITH ALARM OR AUX. SWITCH AND METERING SHUNT</p>		M	A

- Notes:
 1 All dimensions are in inches [millimeters].
 2 Tolerance ±.020 [.51] unless otherwise specified.

Dimensional Specifications: in. [mm]

SERIES TRIP BACK CONNECT (STUD TERMINALS SHOWN)

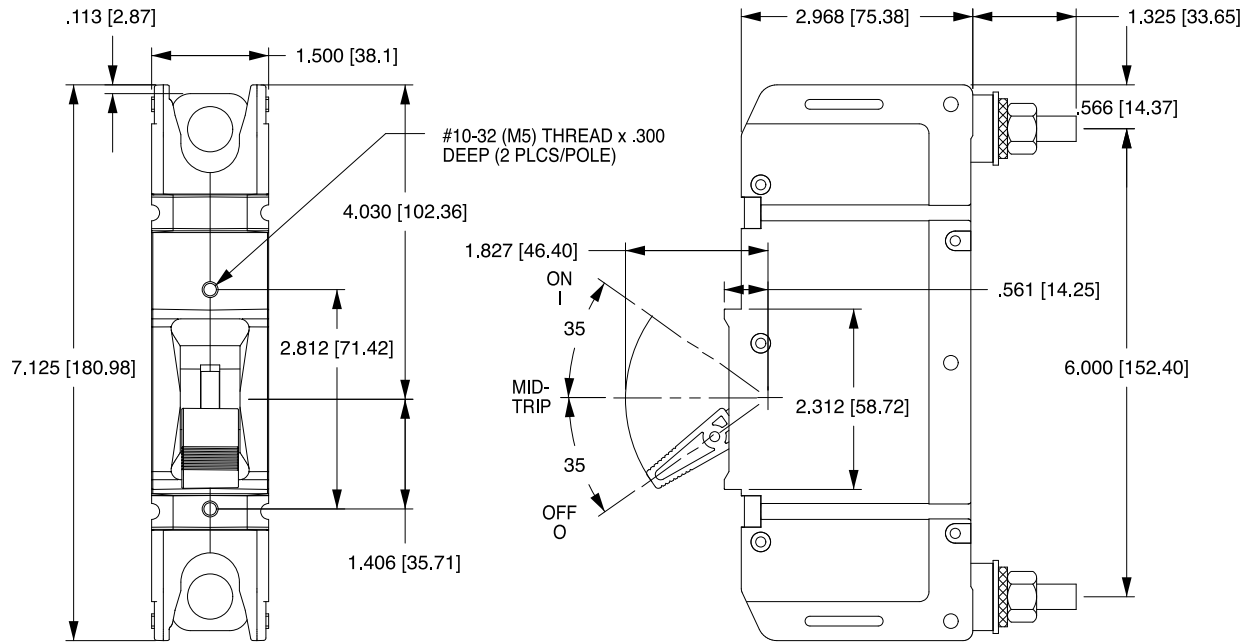

MULTIPOLE SERIES TRIP, SHOWING TERMINAL BARRIER

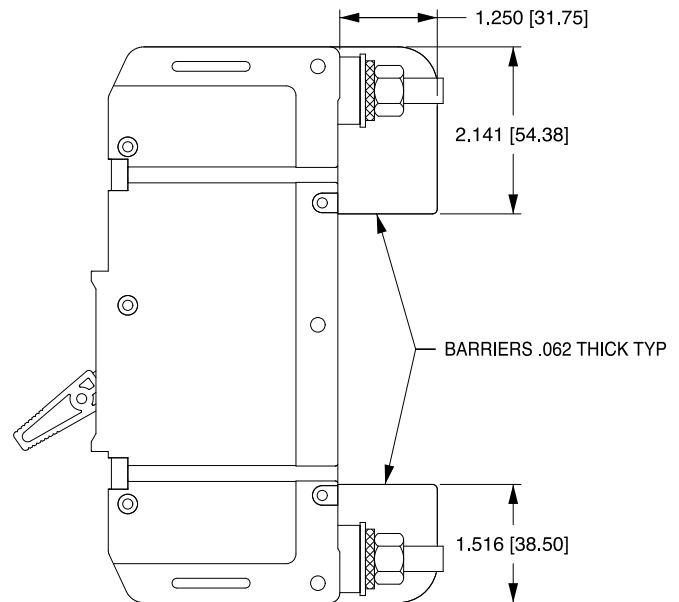
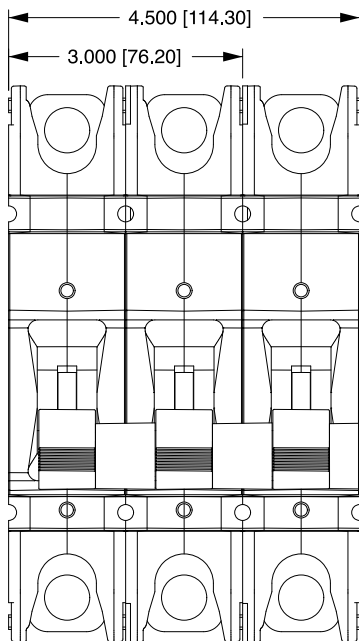

Notes:

- 1 All dimensions are in inches [millimeters].
- 2 Tolerance ± 0.020 [51] unless otherwise specified.

Dimensional Specifications: in. [mm]

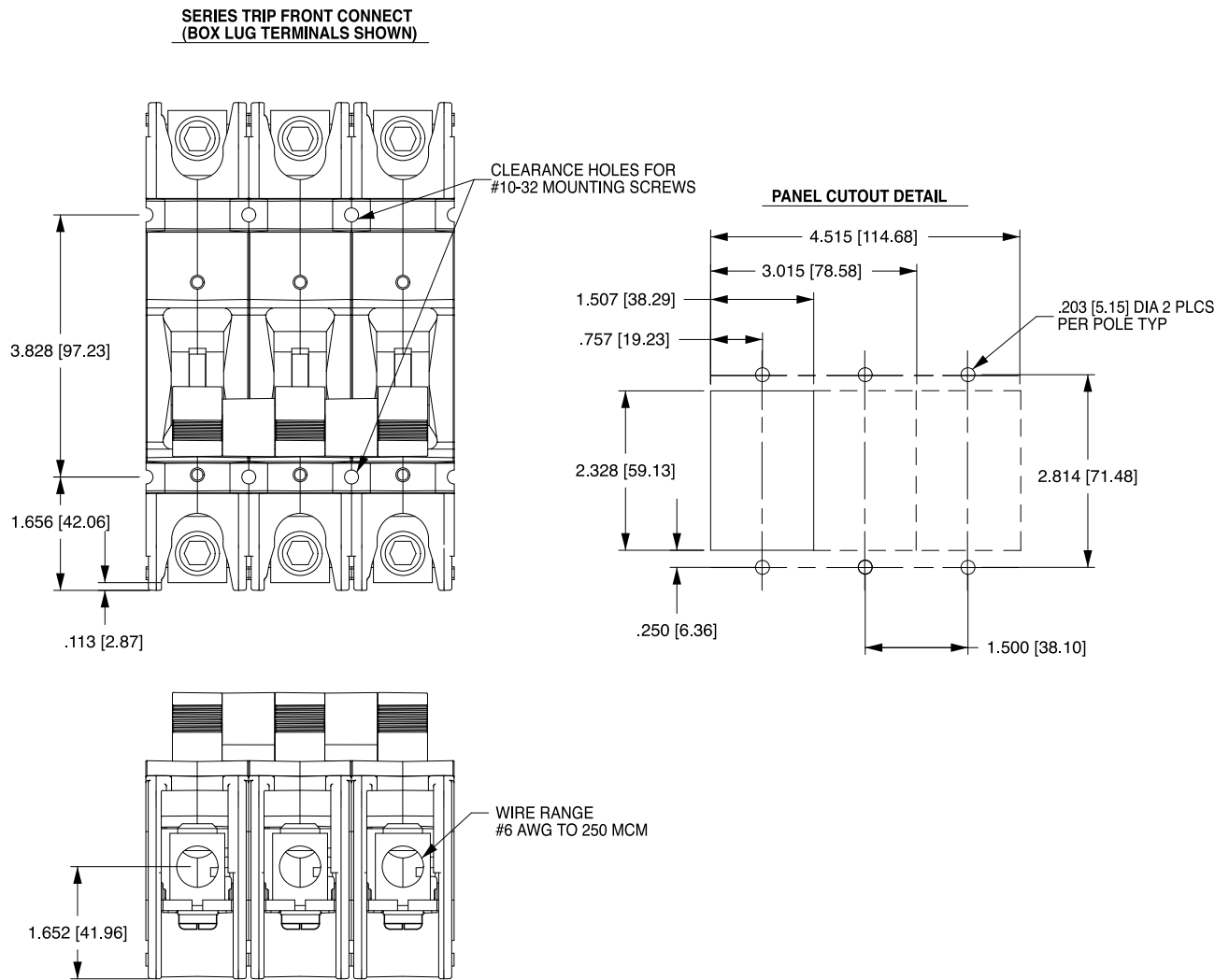

Notes:

- 1 All dimensions are in inches [millimeters].
- 2 Tolerance ± 0.020 [.51] unless otherwise specified.

Dimensional Specifications: in. [mm]

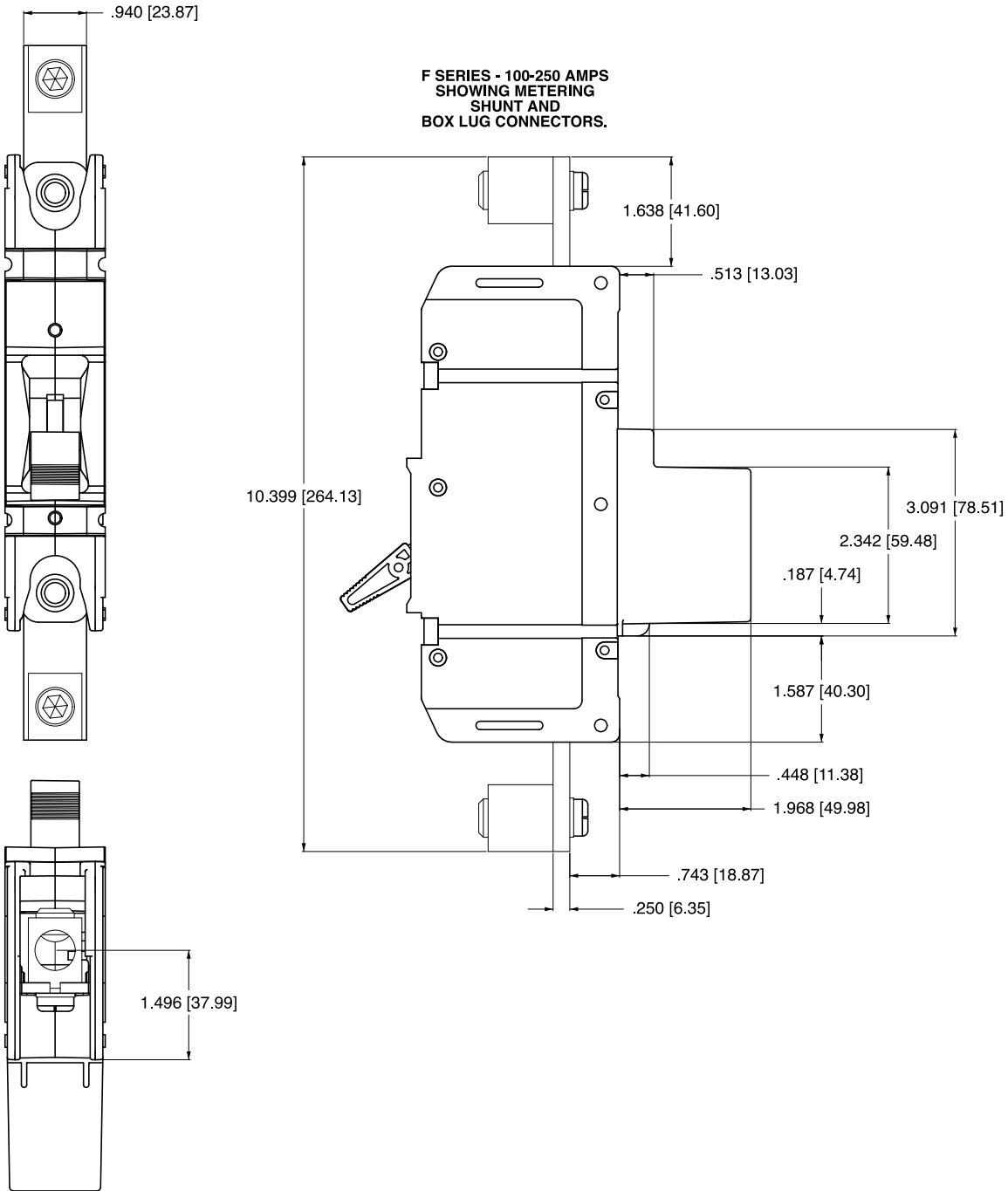

F-Series breakers are available up to 700A, and are also available with a 25 millivolt metering shunt construction. This optional construction provides a safe method for monitoring current flowing through the breaker by simply connecting a meter with light gauge wire to the appropriate terminals located on the shunt housing at the rear of the breaker. You can customize the application by measuring and displaying percentage of current, watts or safe/danger zones.

Notes:

- 1 All dimensions are in inches [millimeters].
- 2 Tolerance ± 0.020 [.51] unless otherwise specified.

Dimensional Specifications: in. [mm]

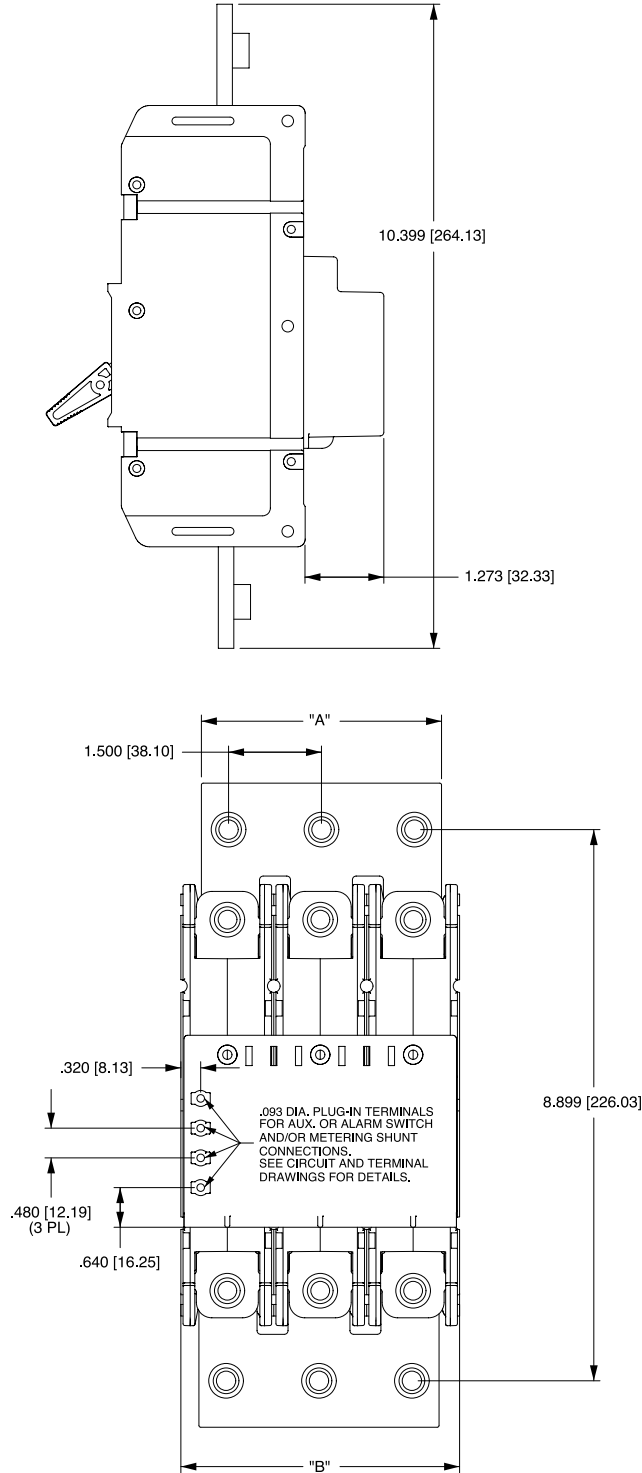

**F-SERIES PARALLEL POLE 250-700 AMPS
SHOWING FRONT CONNECT SCREW TERMINALS**

Notes:

- 1 All dimensions are in inches [millimeters].
- 2 Tolerance ± 0.020 [.51] unless otherwise specified.

F-SERIES TIME DELAY VALUES									
TRIP TIME SECONDS	PERCENT OF RATED CURRENT								
	Delay	100%	125%	150%	200%	400%	600%	800%	1000%
11	No Trip	.013 - .125	.010 - .070	.008 - .032	.006 - .020	.005 - .020	.004 - .020	.004 - .020	.004 - .020
12	No Trip	.475 - 10.0	.275 - 2.80	.140 - .850	.030 - .190	.015 - .125	.010 - .050	.008 - .038	.008 - .038
14	No Trip	10.0 - 110	6.00 - 40.0	2.50 - 15.0	.500 - 3.00	.180 - 1.00	.010 - .280	.008 - .080	.008 - .080
16	No Trip	110 - 1000	60.0 - 400	22.0 - 150	4.00 - 25.0	1.00 - 5.50	.010 - 1.80	.008 - .390	.008 - .390
22	No Trip	.700 - 12.0	.350 - 4.00	.130 - 1.30	.027 - .220	.008 - .130	.004 - .090	.004 - .045	.004 - .045
24	No Trip	10.0 - 160	6.00 - 60.0	.220 - 20.0	.300 - 3.00	.050 - 1.30	.007 - .500	.005 - .060	.005 - .060
26	No Trip	50.0 - 700	32.0 - 350	10.0 - 90.0	1.50 - 15.0	.500 - 7.00	.020 - 3.00	.006 - 2.00	.006 - 2.00

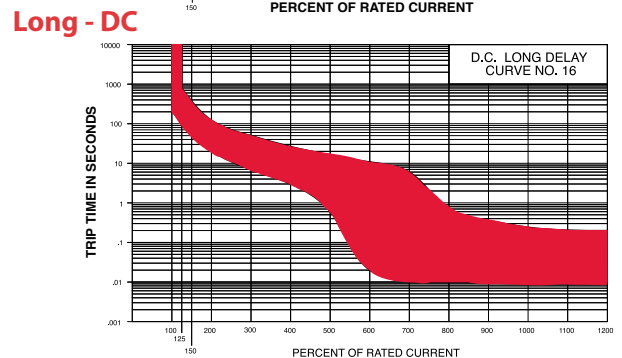
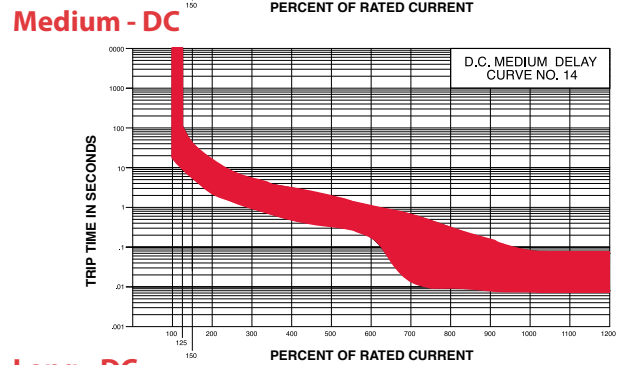
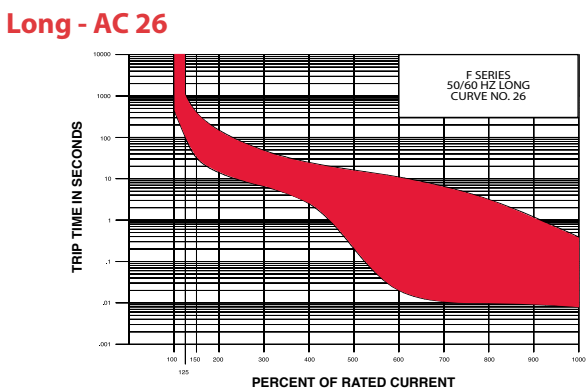
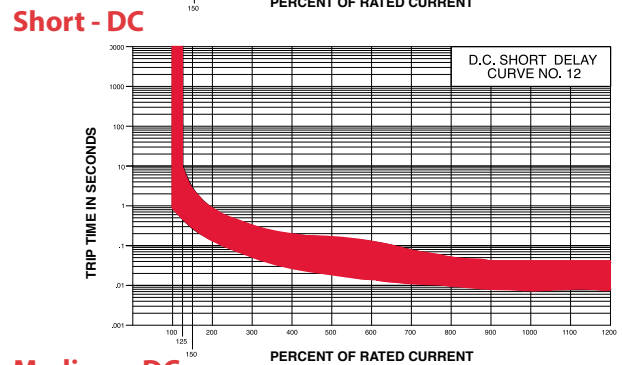
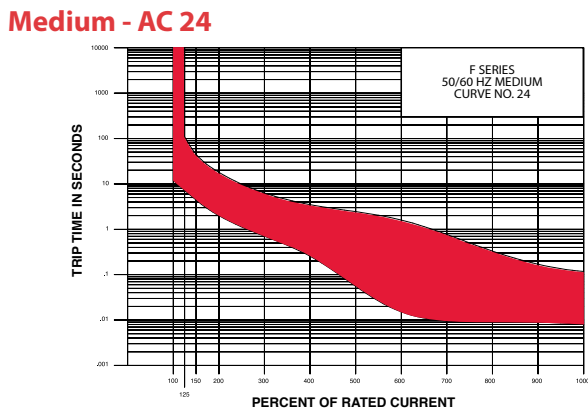
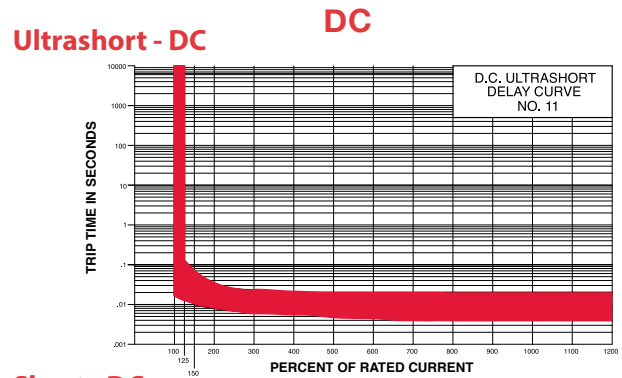
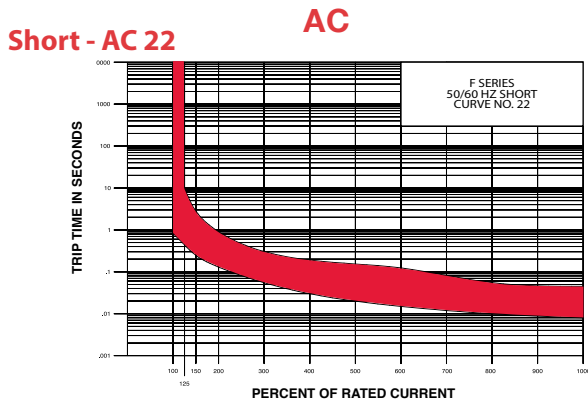

Authorized Sales Representatives and Distributors

Click on a region of the map below to find your local representatives and distributors or visit www.carlingtech.com/findarep.



About Carling

Founded in 1920, Carling Technologies is a leading manufacturer of electrical and electronic switches and assemblies, circuit breakers, electronic controls, power distribution units, and multiplexed power distribution systems. With four ISO registered manufacturing facilities and technical sales offices worldwide, Carling Technologies Sales, Service and Engineering teams do much more than manufacture electrical components, they engineer powerful solutions! To learn more about Carling please visit www.carlingtech.com/company-profile.

To view all of Carling's environmental, quality, health & safety certifications please visit www.carlingtech.com/environmental-certifications

Worldwide Headquarters

Carling Technologies, Inc.
60 Johnson Avenue, Plainville, CT 06062
Phone: 860.793.9281 **Fax:** 860.793.9231
Email: sales@carlingtech.com

Northern Region Sales Office: nrsm@carlingtech.com
Southeast Region Sales Office: sersm@carlingtech.com
Midwest Region Sales Office: mrrsm@carlingtech.com
West Region Sales Office: wrsm@carlingtech.com
Latin America Sales Office: larsm@carlingtech.com

Asia-Pacific Headquarters

Carling Technologies, Asia-Pacific Ltd.,
Suite 1607, 16/F Tower 2, The Gateway,
Harbour City, 25 Canton Road,
Tsimshatsui, Kowloon, Hong Kong
Phone: Int + 852-2737-2277 **Fax:** Int + 852-2736-9332
Email: sales@carlingtech.com.hk

Shenzhen, China: shenzhen@carlingtech.com
Shanghai, China: shanghai@carlingtech.com
Pune, India: india@carlingtech.com
Kaohsiung, Taiwan: taiwan@carlingtech.com
Yokohama, Japan: japan@carlingtech.com

Europe | Middle East | Africa Headquarters

Carling Technologies LTD
4 Airport Business Park, Exeter Airport,
Clyst Honiton, Exeter, Devon, EX5 2UL, UK
Phone: Int + 44 1392.364422 **Fax:** Int + 44 1392.364477
Email: ltd.sales@carlingtech.com

Germany: gmbh@carlingtech.com
France: sas@carlingtech.com



Carling Technologies®

Innovative Designs. Powerful Solutions.

Mouser Electronics

Authorized Distributor

Click to View Pricing, Inventory, Delivery & Lifecycle Information:

Carling Technologies:

[FA1-A0-03-825-12A-BA](#) [FA1-A2-03-825-32A-AA](#) [FA1-A2-03-825-32A-BA](#) [FA1-B0-11-815-12A-BG](#) [FA1-B0-12-815-42A-BG](#) [FA1-B0-12-820-12B-BG](#) [FA1-B0-12-825-11A-BG](#) [FA1-B0-12-825-12A-BG](#) [FA1-B0-12-825-1BA-BG](#) [FA1-B0-12-825-31A-BG](#) [FA1-B0-12-825-31A-BJ](#) [FA1-B0-12-917-11A-BG](#) [FA1-B0-14-810-12A-BG](#) [FA1-B0-14-815-11A-BA](#) [FA1-B0-14-815-12A-BG](#) [FA1-B0-14-815-12A-BJ](#) [FA1-B0-14-815-12B-BG](#) [FA1-B0-14-815-31A-BG](#) [FA1-B0-14-815-32A-BG](#) [FA1-B0-14-815-3BA-BG](#) [FA1-B0-14-820-11A-BA](#) [FA1-B0-14-820-12A-BG](#) [FA1-B0-14-820-12A-BJ](#) [FA1-B0-14-820-1DB-BG](#) [FA1-B0-14-820-22A-BG](#) [FA1-B0-14-820-3BA-BG](#) [FA1-B0-14-825-11A-BA](#) [FA1-B0-14-825-11A-BJ](#) [FA1-B0-14-825-12A-BJ](#) [FA1-B0-14-825-12B-BJ](#) [FA1-B0-14-825-1DA-BG](#) [FA1-B0-14-825-22A-BG](#) [FA1-B0-14-825-22B-BG](#) [FA1-B0-14-825-42A-BG](#) [FA1-B0-14-825-42B-BJ](#) [FA1-B0-14-825-52A-BG](#) [FA1-B0-14-912-12A-BG](#) [FA1-B0-14-912-12B-BG](#) [FA1-B0-14-917-12A-BG](#) [FA1-B0-14-917-41A-BG](#) [FA1-B0-14-922-12A-BG](#) [FA1-B0-14-922-42B-BJ](#) [FA1-B0-16-810-32A-BG](#) [FA1-B0-16-810-42A-BG](#) [FA1-B0-16-815-32A-BG](#) [FA1-B0-16-820-12A-BG](#) [FA1-B0-16-820-32A-BG](#) [FA1-B0-16-825-11A-BG](#) [FA1-B0-16-825-11B-BJ](#) [FA1-B0-16-825-12A-BT](#) [FA1-B0-16-825-31A-BJ](#) [FA1-B0-16-825-32A-BG](#) [FA1-B0-16-825-41B-BJ](#) [FA1-B2-12-815-12B-BG](#) [FA1-B2-12-815-32A-BG](#) [FA1-B2-12-825-12B-BG](#) [FA1-B2-12-825-12B-BJ](#) [FA1-B2-12-825-22A-BG](#) [FA1-B2-12-917-12A-BG](#) [FA1-B2-12-922-12A-BG](#) [FA1-B2-14-810-42A-BG](#) [FA1-B2-14-815-12A-BG](#) [FA1-B2-14-815-32A-BG](#) [FA1-B2-14-820-12A-BG](#) [FA1-B2-14-820-22A-BG](#) [FA1-B2-14-820-32A-BG](#) [FA1-B2-14-820-42A-BG](#) [FA1-B2-14-820-52A-BG](#) [FA1-B2-14-825-12B-BG](#) [FA1-B2-14-825-12B-BJ](#) [FA1-B2-14-825-22A-BG](#) [FA1-B2-14-912-12A-BG](#) [FA1-B2-14-922-31B-BG](#) [FA1-B3-12-912-12A-BG](#) [FA1-B4-12-825-12A-BG](#) [FA1-B4-12-912-12A-BG](#) [FA1-B4-14-815-12A-BG](#) [FA1-B9-12-815-32A-BG](#) [FA1-B9-14-810-22A-BG](#) [FA1-B9-14-825-22A-BG](#) [FA1-M0-14-825-42A-BG](#) [FA1-PB-16-922-22A-BA](#) [FA2-A0-03-825-12A-BA](#) [FA2-A0-03-825-42A-BA](#) [FA2-B0-12-810-12A-BG](#) [FA2-B0-12-815-32B-BG](#) [FA2-B0-12-815-52B-BA](#) [FA2-B0-12-815-52B-BG](#) [FA2-B0-12-820-12A-BG](#) [FA2-B0-12-825-11A-BG](#) [FA2-B0-14-810-11A-BG](#) [FA2-B0-14-810-12A-BG](#) [FA2-B0-14-810-12B-BG](#) [FA2-B0-14-815-11B-BA](#) [FA2-B0-14-815-12A-BG](#) [FA2-B0-14-815-12B-BG](#) [FA2-B0-14-815-42A-BJ](#) [FA2-B0-14-820-11A-BA](#) [FA2-B0-14-820-11A-BJ](#) [FA2-B0-14-820-12B-BG](#)