

DATA SHEET



LDMOS FIELD EFFECT TRANSISTOR NE55410GR

N-CHANNEL SILICON POWER LDMOS FET FOR 2 W + 10 W VHF to L-BAND SINGLE-END POWER AMPLIFIER

DESCRIPTION

The NE55410GR is an N-channel enhancement-mode LDMOS FET designed for driver 0.1 to 2.6 GHz PA, such as, cellular base station amplifier, analog/digital TV-transmitters, and the other PA's. This product has two different FET's on one die manufactured using our NEWMOS technology (our WSi gate lateral MOS FET), and its nitride surface passivation and quadruple layer aluminum silicon metalization offer a high degree of reliability.

FEATURES

- Two different FET's (Q1 : $P_{out} = 2\text{ W}$, Q2 : $P_{out} = 10\text{ W}$) in one package
- Over 25 dB gain available by connecting two FET's in series
 - : $G_L(Q1) = 13.5\text{ dB TYP.}$ ($V_{DS} = 28\text{ V}$, $I_{Dset}(Q1) = 20\text{ mA}$, $f = 2\text{ 140 MHz}$)
 - : $G_L(Q2) = 11.0\text{ dB TYP.}$ ($V_{DS} = 28\text{ V}$, $I_{Dset}(Q2) = 100\text{ mA}$, $f = 2\text{ 140 MHz}$)
- High 1 dB compression output power
 - : $P_{O(1\text{ dB})}(Q1) = 35.4\text{ dBm TYP.}$ ($V_{DS} = 28\text{ V}$, $I_{Dset}(Q1) = 20\text{ mA}$, $f = 2\text{ 140 MHz}$)
 - : $P_{O(1\text{ dB})}(Q2) = 40.4\text{ dBm TYP.}$ ($V_{DS} = 28\text{ V}$, $I_{Dset}(Q2) = 100\text{ mA}$, $f = 2\text{ 140 MHz}$)
- High drain efficiency
 - : $\eta_d(Q1) = 52\% \text{ TYP.}$ ($V_{DS} = 28\text{ V}$, $I_{Dset}(Q1) = 20\text{ mA}$, $f = 2\text{ 140 MHz}$)
 - : $\eta_d(Q2) = 46\% \text{ TYP.}$ ($V_{DS} = 28\text{ V}$, $I_{Dset}(Q2) = 100\text{ mA}$, $f = 2\text{ 140 MHz}$)
- Low intermodulation distortion
 - : $IM_3(Q1) = -40\text{ dBc TYP.}$ ($V_{DS} = 28\text{ V}$, $I_{Dset}(Q1+Q2) = 120\text{ mA}$,
 $f = 2\text{ 132.5/2 147.5 MHz}$, $P_{out} = 33\text{ dBm}$ (2 tones))
- <R> • Single Supply ($V_{DS} : 3\text{ V} < V_{DS} \leq 32\text{ V}$)
- Excellent Thermal Stability
- Surface mount type and Super low cost plastic package : 16-pin plastic HTSSOP
- Integrated ESD protection
- Excellent stability against HCI (Hot Carrier Injection)

APPLICATION

- <R> • Digital cellular base station PA : W-CDMA/GSM/D-AMPS/N-CDMA/PCS etc.
- UHF-band TV transmitter PA

Caution Observe precautions when handling because these devices are sensitive to electrostatic discharge.

The information in this document is subject to change without notice. Before using this document, please confirm that this is the latest version.

ORDERING INFORMATION

Part Number	Order Number	Package	Marking	Supplying Form
NE55410GR	NE55410GR-T3-AZ	16-pin plastic HTSSOP (Pb-Free) ^{Note}	55410	<ul style="list-style-type: none"> • Embossed tape 12 mm wide • Pin 1 and 8 indicates pull-out direction of tape • Qty 1 kpcs/reel

Note With regards to terminal solder (the solder contains lead) plated products (conventionally plated), contact your nearby sales office.

Remark To order evaluation samples, contact your nearby sales office.
Part number for sample order: NE55410GR

PIN CONNECTIONS AND INTERNAL BLOCK DIAGRAM

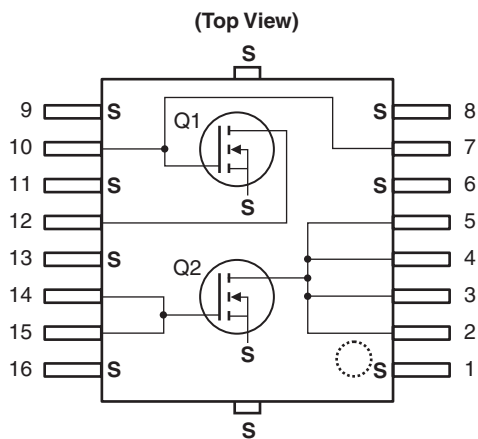

Pin No.	Pin Name	Pin No.	Pin Name
1	Source	9	Source
2	Drain (Q2)	10	Gate (Q1)
3	Drain (Q2)	11	Source
4	Drain (Q2)	12	Drain (Q1)
5	Drain (Q2)	13	Source
6	Source	14	Gate (Q2)
7	Gate (Q1)	15	Gate (Q2)
8	Source	16	Source

Remark All the terminals of a Q2 connected to a circuit. Backside : Source (S)

ABSOLUTE MAXIMUM RATINGS (T_A = +25°C, unless otherwise specified)

Parameter	Symbol	Test Conditions	Ratings	Unit
Drain to Source Voltage	V _{DS}		65	V
Gate to Source Voltage	V _{GS}		±7	V
Drain Current (Q1)	I _{D (Q1)}		0.25	A
Drain Current (Q2)	I _{D (Q2)}		1.0	A
Total Device Dissipation (T _{case} = 25°C)	P _{tot}		40	W
Input Power (Q1)	P _{in (Q1)}	f = 2.14 GHz, V _{DS} = 28 V	0.3	W
Input Power (Q2)	P _{in (Q2)}	f = 2.14 GHz, V _{DS} = 28 V	1.5	W
Channel Temperature	T _{ch}		150	°C
Storage Temperature	T _{stg}		-65 to +150	°C

THERMAL RESISTANCE (T_A = +25°C)

Parameter	Symbol	Test Conditions	MIN.	TYP.	MAX.	Unit
Channel to Case Resistance	R _{th (ch-c)}		–	2.5	3.0	°C/W

RECOMMENDED OPERATING CONDITIONS (T_A = +25°C)

Parameter	Symbol	MIN.	TYP.	MAX.	Unit
<R> Drain to Source Voltage	V _{DS}	–	28	32	V
Gate to Source Voltage	V _{GS}	2.7	3.3	3.7	V
Input Power (Q1), CW	P _{in (Q1)}	–	15	23	dBm
Input Power (Q2), CW	P _{in (Q2)}	–	20	30	dBm
<R> Average Output Power (Q1), CW ^{Note}	P _{O (ave.) (Q1)}	–	–	24	dBm
<R> Average Output Power (Q2), CW ^{Note}	P _{O (ave.) (Q2)}	–	–	30	dBm

<R> **Note** When mounting on the PWB that our company recommends.

ELECTRICAL CHARACTERISTICS (T_A = +25°C)

Parameter	Symbol	Test Conditions	MIN.	TYP.	MAX.	Unit
Q1						
Gate to Source Leak Current	I _{GSS (Q1)}	V _{GSS} = 5V	–	–	1	μA
Drain to Source Leakage Current	I _{DSS (Q1)}	V _{DSS} = 65 V	–	–	1	mA
Gate Threshold Voltage	V _{th (Q1)}	V _{DS} = 10 V, I _{DS} = 1 mA	2.2	2.8	3.4	V
Transconductance	g _{m (Q1)}	V _{DS} = 28 V, I _{DS} = 20 mA	–	0.09	–	S
Drain to Source Breakdown Voltage	BV _{DSS (Q1)}	I _{DSS} = 10 μA	65	75	–	V
Q2						
Gate to Source Leak Current	I _{GSS (Q2)}	V _{GSS} = 5V	–	–	1	μA
Drain to Source Leakage Current	I _{DSS (Q2)}	V _{DSS} = 65 V	–	–	1	mA
Gate Threshold Voltage	V _{th (Q2)}	V _{DS} = 10 V, I _{DS} = 1 mA	2.0	2.6	3.2	V
Transconductance	g _{m (Q2)}	V _{DS} = 28 V, I _{DS} = 100 mA	–	0.45	–	S
Drain to Source Breakdown Voltage	BV _{DSS (Q2)}	I _{DSS} = 10 μA	65	75	–	V

<R> RF CHARACTERISTICS (T_A = +25°C)

Parameter	Symbol	Test Conditions	MIN.	TYP.	MAX.	Unit
Q1						
Gain 1 dB Compression Output Power	P _{O (1 dB)}	f = 2 140 MHz, V _{DS} = 28 V,	–	35.4	–	dBm
Drain Efficiency	η _d	I _{Dset} = 20 mA	–	52	–	%
Linear Gain	G _L ^{Note1}		12	13.5	–	dB
Q2						
Gain 1 dB Compression Output Power	P _{O (1 dB)}	f = 2 140 MHz, V _{DS} = 28 V,	–	40.4	–	dBm
Drain Efficiency	η _d	I _{Dset} = 100 mA	–	46	–	%
Linear Gain	G _L ^{Note2}		9.5	11	–	dB
Gain 1 dB Compression Output Power	P _{O (1 dB)}	f = 1 840 MHz, V _{DS} = 28 V,	–	40.5	–	dBm
Drain Efficiency	η _d	I _{Dset} = 100 mA	–	49	–	%
Linear Gain	G _L ^{Note2}		–	14	–	dB
Q1 + Q2						
Gain 1 dB Compression Output Power	P _{O (1 dB)}	f = 880 MHz, V _{DS} = 28 V,	–	41.5	–	dBm
Drain Efficiency	η _d	I _{Dset} = 120 mA (Q1 + Q2)	–	55	–	%
Linear Gain	G _L ^{Note3}		–	30	–	dB
Gain 1 dB Compression Output Power	P _{O (1 dB)}	f = 2 140 MHz, V _{DS} = 28 V,	–	40.0	–	dBm
Drain Efficiency	η _d	I _{Dset} = 120 mA (Q1 + Q2)	34	42	–	%
Output Power	P _{out}		39	40	–	dB
Linear Gain	G _L ^{Note4}		24	25	–	dB
3rd Order Intermodulation Distortion	IM ₃	f = 2 132.5/2 147.5 MHz, V _{DS} = 28 V,	–	–40	–	dBc
Drain Efficiency	η _d	2 carrier W-CDMA 3GPP, Test Model1, 64DPCH, 67% Clipping, I _{Dset} = 120 mA (Q1 + Q2), Ave P _{out} = 33 dBm	–	21	–	%

- Notes 1. P_{in} = 15 dBm
- 2. P_{in} = 20 dBm
- 3. P_{in} = 5 dBm
- 4. P_{in} = 10 dBm

TYPICAL CHARACTERISTICS (TA = +25°C, VDS = 28 V, Idset = 120 mA, unless otherwise specified)

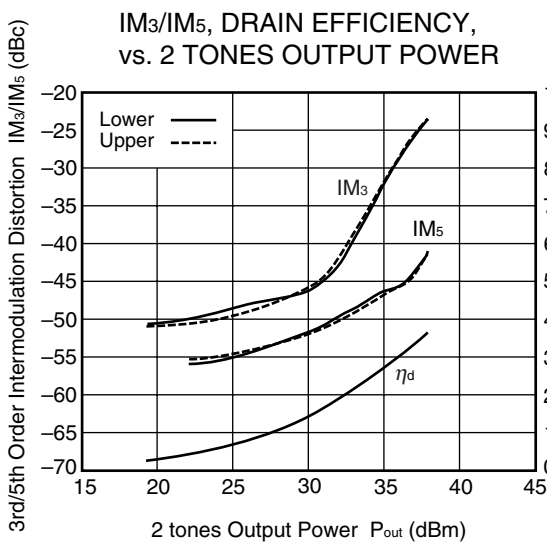
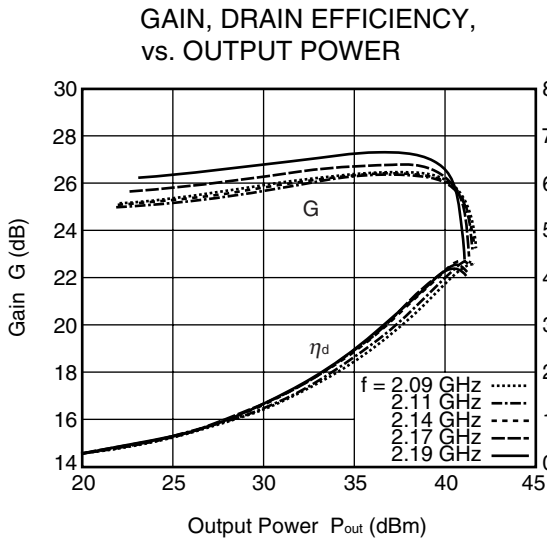
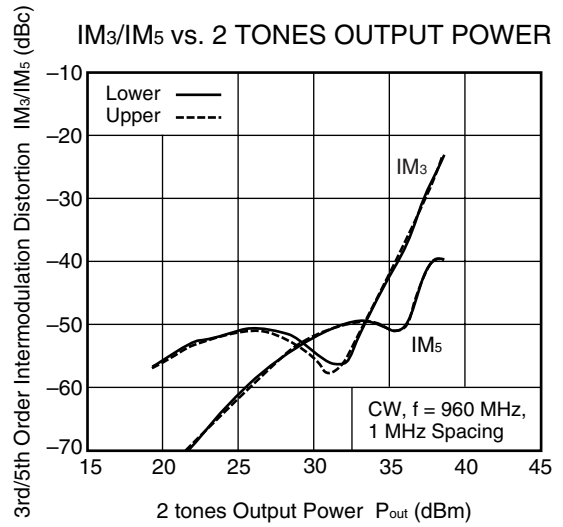
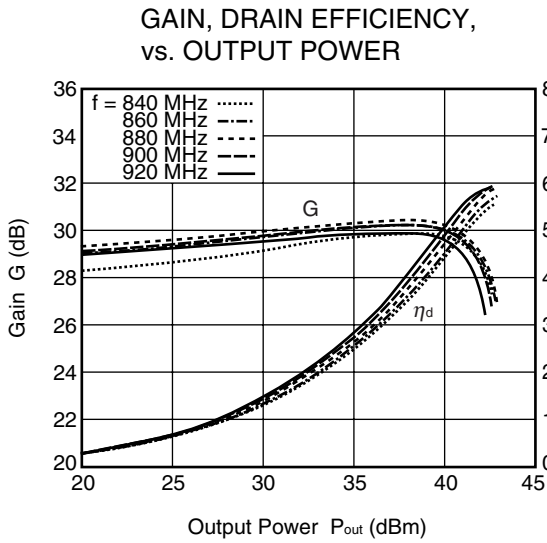

W-CDMA 3GPP, Test Model 1,
 64 DPCH, 67% Clipping,
 Center Frequency 2.14GHz,
 15 MHz spacing

Remark The graphs indicate nominal characteristics.

<R> **S-PARAMETERS**

S-parameters/Noise parameters are provided on our web site in a form (S2P) that enables direct import to a microwave circuit simulator without keyboard input.

Click here to download S-parameters.

[RF and Microwave] → [Device Parameters]

URL <http://www.ncsd.necel.com/microwave/index.html>

EVALUATION CIRCUIT (f = 840 to 960 MHz, V_{DS} = 28 V, I_{Dset} = 120 mA)

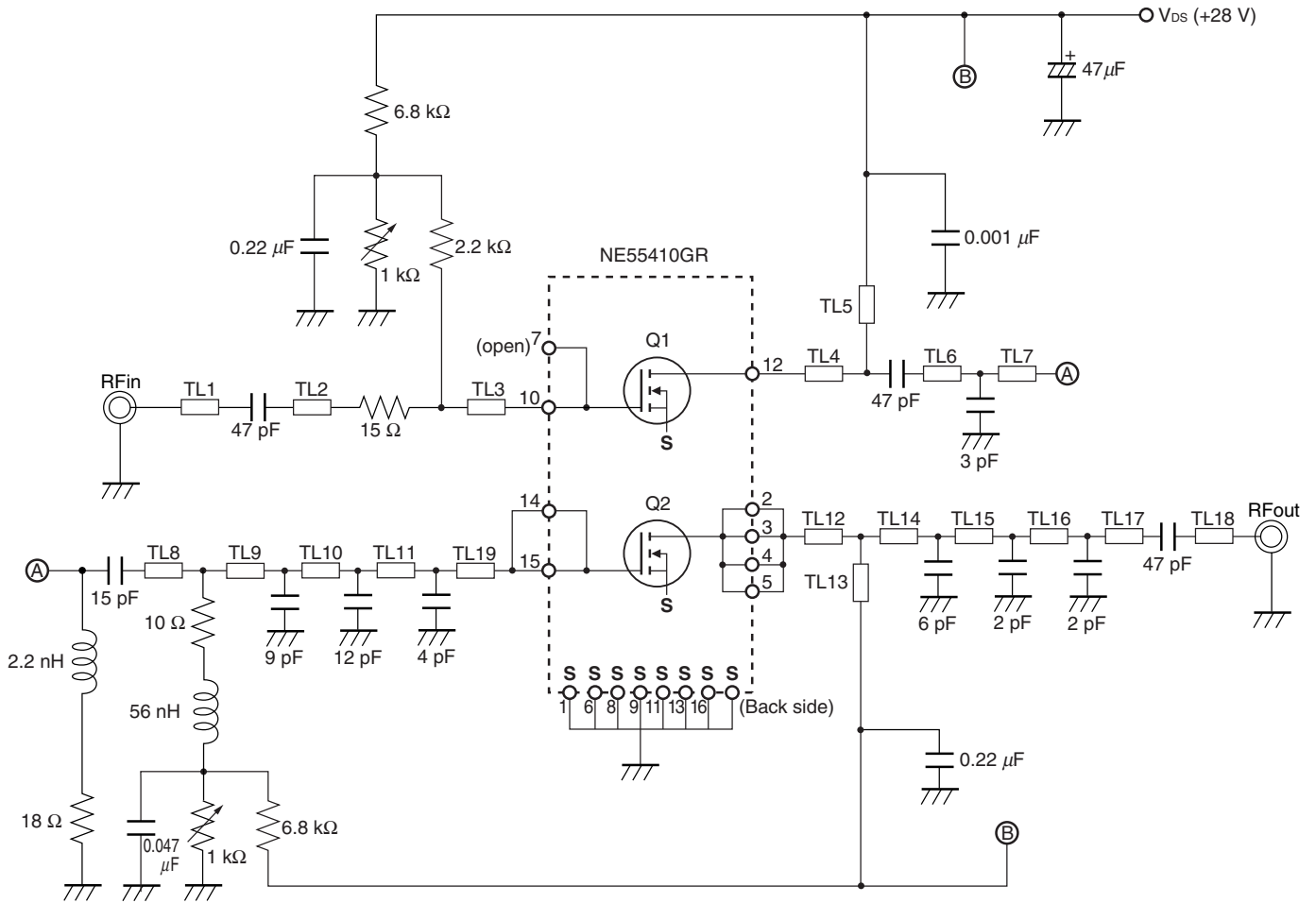

Symbol	Width (mm)	Length (mm)
TL1	1.0	3.0
TL2	4.5	10.0
TL3	0.5	16.0
TL4	0.5	5.0
TL5	1.0	48.0
TL6	1.0	4.0
TL7	1.0	3.0
TL8	1.0	6.0
TL9	1.0	3.0
TL10	1.0	4.0

Symbol	Width (mm)	Length (mm)
TL11	1.0	3.0
TL12	1.0	5.0
TL13	0.8	48.0
TL14	1.0	6.5
TL15	1.0	10.5
TL16	1.0	9.5
TL17	1.0	10.0
TL18	1.0	6.0
TL19	1.0	3.0

The application circuits and their parameters are for reference only and are not intended for use in actual design-ins.

EVALUATION CIRCUIT (f = 840 to 960 MHz, V_{DS} = 28 V, I_{Dset} = 120 mA)

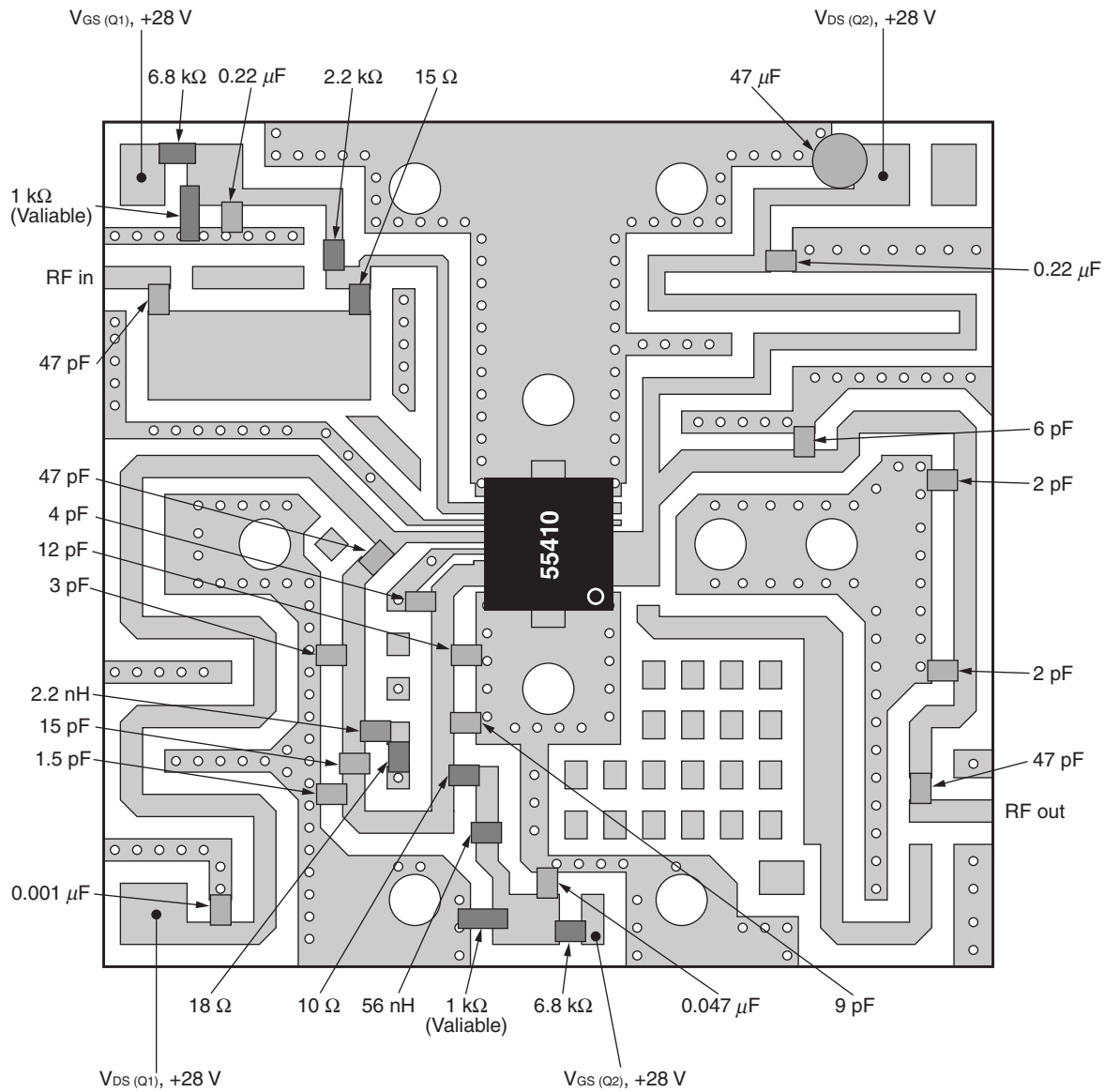

EVALUATION CIRCUIT (f = 2 090 to 2 190 MHz, V_{DS} = 28 V, I_{Dset} = 120 mA)

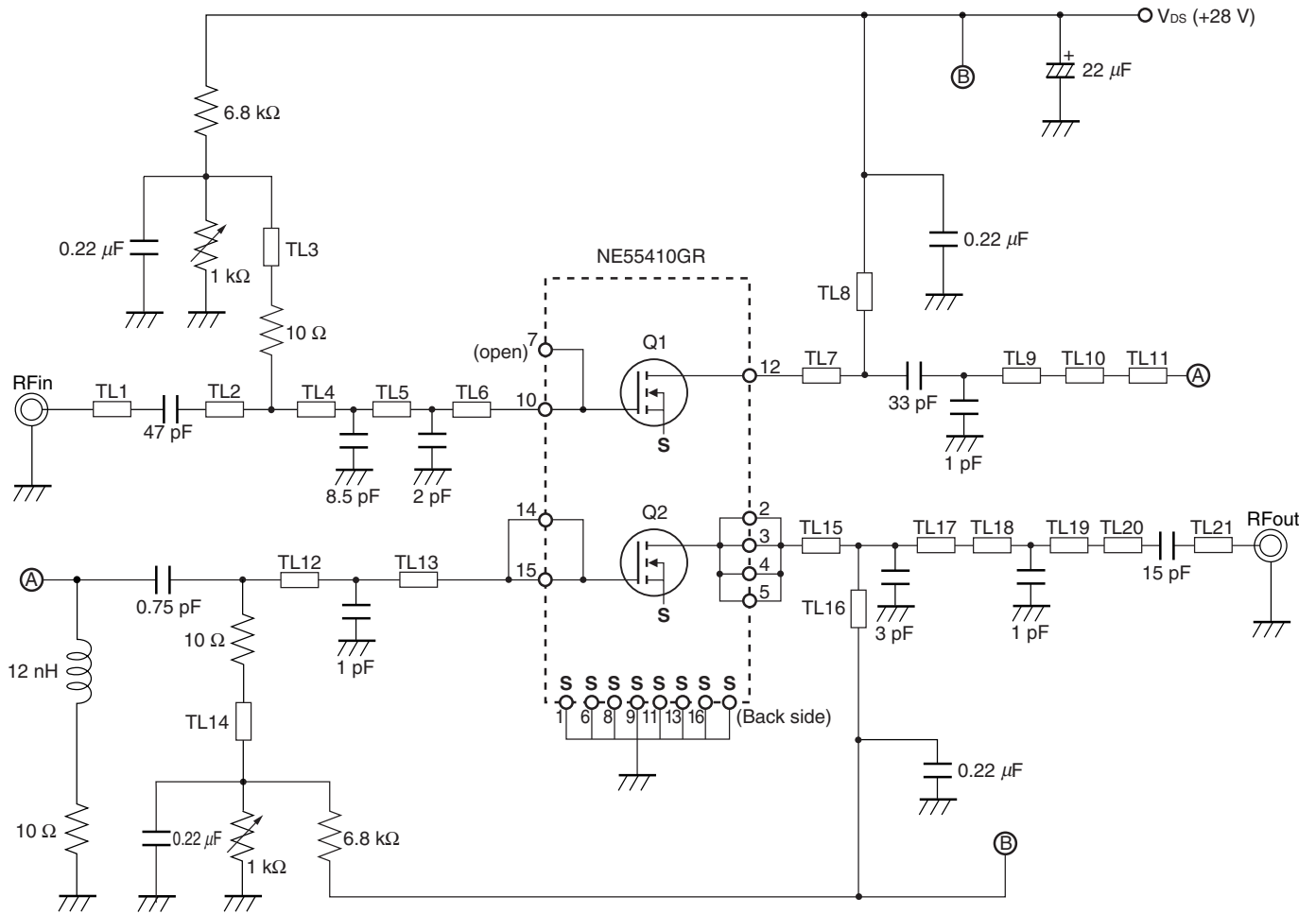

Symbol	Width (mm)	Length (mm)
TL1	1.0	17.0
TL2	1.0	4.0
TL3	1.0	24.5
TL4	1.0	2.5
TL5	1.0	3.0
TL6	0.5	2.5
TL7	0.5	4.5
TL8	1.0	25.5
TL9	1.0	2.5
TL10	4.5	4.5
TL11	1.0	3.5

Symbol	Width (mm)	Length (mm)
TL12	1.0	4.0
TL13	1.0	4.5
TL14	1.0	25.0
TL15	2.5	2.5
TL16	1.0	27.0
TL17	1.0	2.0
TL18	5.0	4.0
TL19	5.0	2.0
TL20	1.0	12.5
TL21	1.0	5.5

The application circuits and their parameters are for reference only and are not intended for use in actual design-ins.

<R> **EVALUATION CIRCUIT ($f = 2\ 090$ to $2\ 190$ MHz, $V_{DS} = 28$ V, $I_{Dset} = 120$ mA)**

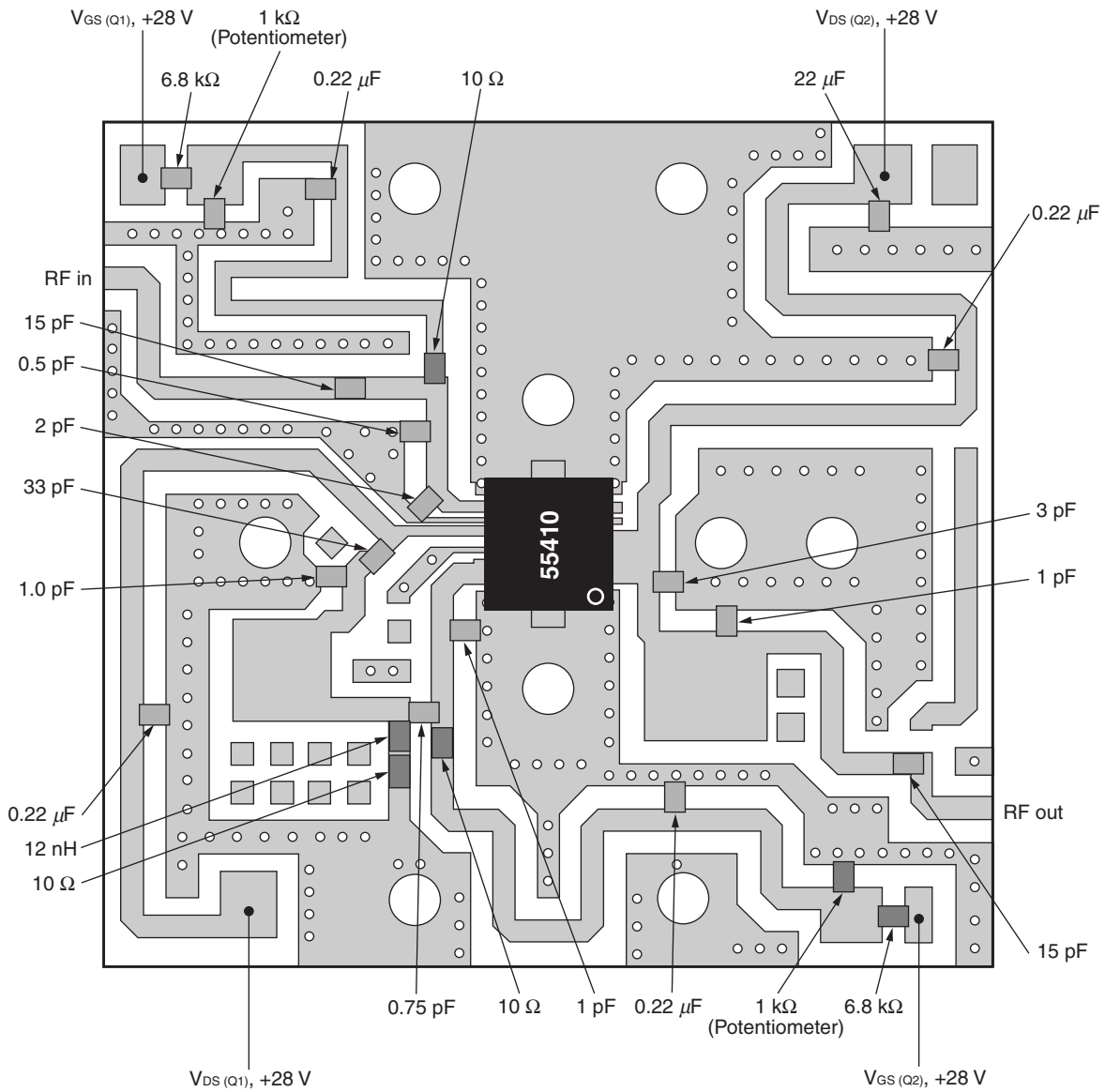

PACKAGE DIMENSIONS

16-PIN PLASTIC HTSSOP (UNIT: mm)

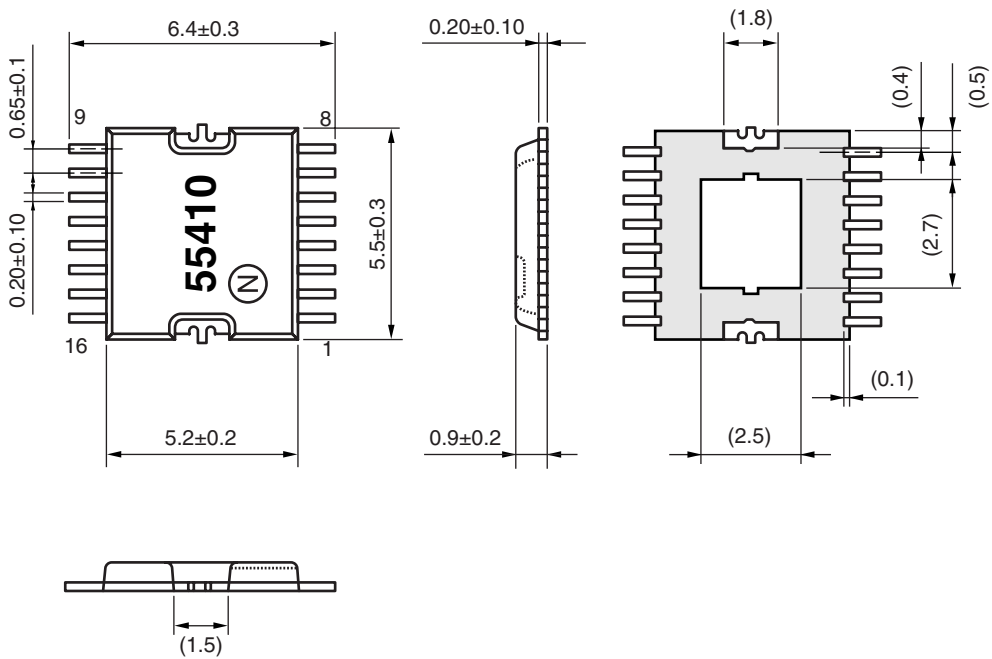

Remark (): Reference value

LAND PATTERN (UNIT: mm)

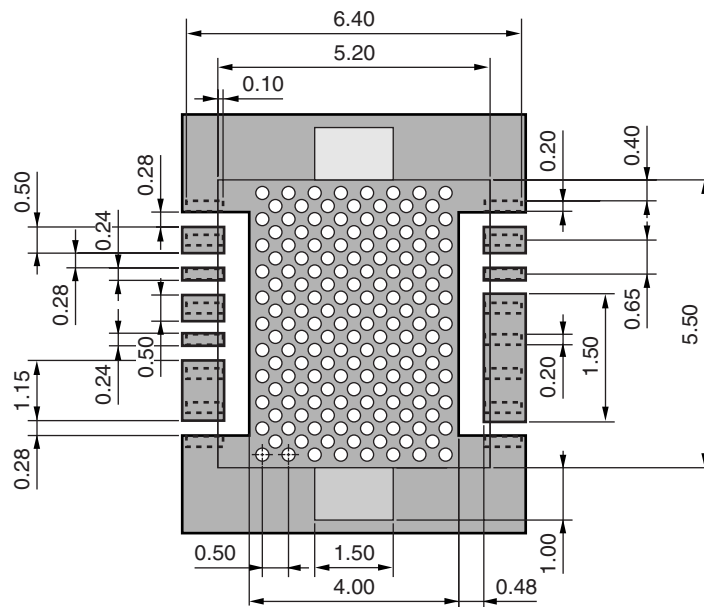

- Remarks**
1. Via holes : 158 holes
 2. Hole size : $\phi 0.15$ mm
 3. Min. spacing : 0.354 mm
 4.  : Solder resist or etching

<R>

RECOMMENDED SOLDERING CONDITIONS

This product should be soldered and mounted under the following recommended conditions. For soldering methods and conditions other than those recommended below, contact your nearby sales office.

Soldering Method	Soldering Conditions	Condition Symbol
Infrared Reflow	Peak temperature (package surface temperature) : 260°C or below Time at peak temperature : 10 seconds or less Time at temperature of 220°C or higher : 60 seconds or less Preheating time at 120 to 180°C : 120±30 seconds Maximum number of reflow processes : 3 times Maximum chlorine content of rosin flux (% mass) : 0.2%(Wt.) or below	IR260
Wave Soldering	Peak temperature (molten solder temperature) : 260°C or below Time at peak temperature : 10 seconds or less Preheating temperature (package surface temperature) : 120°C or below Maximum number of flow processes : 1 time Maximum chlorine content of rosin flux (% mass) : 0.2%(Wt.) or below	WS260
Partial Heating	Peak temperature (terminal temperature) : 350°C or below Soldering time (per side of device) : 3 seconds or less Maximum chlorine content of rosin flux (% mass) : 0.2%(Wt.) or below	HS350

Caution Do not use different soldering methods together (except for partial heating).

NOTICE

1. Descriptions of circuits, software and other related information in this document are provided only to illustrate the operation of semiconductor products and application examples. You are fully responsible for the incorporation of these circuits, software, and information in the design of your equipment. California Eastern Laboratories and Renesas Electronics assumes no responsibility for any losses incurred by you or third parties arising from the use of these circuits, software, or information.
2. California Eastern Laboratories has used reasonable care in preparing the information included in this document, but California Eastern Laboratories does not warrant that such information is error free. California Eastern Laboratories and Renesas Electronics assumes no liability whatsoever for any damages incurred by you resulting from errors in or omissions from the information included herein.
3. California Eastern Laboratories and Renesas Electronics do not assume any liability for infringement of patents, copyrights, or other intellectual property rights of third parties by or arising from the use of Renesas Electronics products or technical information described in this document. No license, express, implied or otherwise, is granted hereby under any patents, copyrights or other intellectual property rights of California Eastern Laboratories or Renesas Electronics or others.
4. You should not alter, modify, copy, or otherwise misappropriate any Renesas Electronics product, whether in whole or in part. California Eastern Laboratories and Renesas Electronics assume no responsibility for any losses incurred by you or third parties arising from such alteration, modification, copy or otherwise misappropriation of Renesas Electronics product.
5. Renesas Electronics products are classified according to the following two quality grades: "Standard" and "High Quality". The recommended applications for each Renesas Electronics product depends on the product's quality grade, as indicated below. "Standard": Computers; office equipment; communications equipment; test and measurement equipment; audio and visual equipment; home electronic appliances; machine tools; personal electronic equipment; and industrial robots etc. "High Quality": Transportation equipment (automobiles, trains, ships, etc.); traffic control systems; anti-disaster systems; anti-crime systems; and safety equipment etc. Renesas Electronics products are neither intended nor authorized for use in products or systems that may pose a direct threat to human life or bodily injury (artificial life support devices or systems, surgical implantations etc.), or may cause serious property damages (nuclear reactor control systems, military equipment etc.). You must check the quality grade of each Renesas Electronics product before using it in a particular application. You may not use any Renesas Electronics product for any application for which it is not intended. California Eastern Laboratories and Renesas Electronics shall not be in any way liable for any damages or losses incurred by you or third parties arising from the use of any Renesas Electronics product for which the product is not intended by California Eastern Laboratories or Renesas Electronics.
6. You should use the Renesas Electronics products described in this document within the range specified by California Eastern Laboratories, especially with respect to the maximum rating, operating supply voltage range, movement power voltage range, heat radiation characteristics, installation and other product characteristics. California Eastern Laboratories shall have no liability for malfunctions or damages arising out of the use of Renesas Electronics products beyond such specified ranges.
7. Although Renesas Electronics endeavors to improve the quality and reliability of its products, semiconductor products have specific characteristics such as the occurrence of failure at a certain rate and malfunctions under certain use conditions. Further, Renesas Electronics products are not subject to radiation resistance design. Please be sure to implement safety measures to guard them against the possibility of physical injury, and injury or damage caused by fire in the event of the failure of a Renesas Electronics product, such as safety design for hardware and software including but not limited to redundancy, fire control and malfunction prevention, appropriate treatment for aging degradation or any other appropriate measures. Because the evaluation of microcomputer software alone is very difficult, please evaluate the safety of the final products or systems manufactured by you.
8. Please contact a California Eastern Laboratories sales office for details as to environmental matters such as the environmental compatibility of each Renesas Electronics product. Please use Renesas Electronics products in compliance with all applicable laws and regulations that regulate the inclusion or use of controlled substances, including without limitation, the EU RoHS Directive. California Eastern Laboratories and Renesas Electronics assume no liability for damages or losses occurring as a result of your noncompliance with applicable laws and regulations.
9. Renesas Electronics products and technology may not be used for or incorporated into any products or systems whose manufacture, use, or sale is prohibited under any applicable domestic or foreign laws or regulations. You should not use Renesas Electronics products or technology described in this document for any purpose relating to military applications or use by the military, including but not limited to the development of weapons of mass destruction. When exporting the Renesas Electronics products or technology described in this document, you should comply with the applicable export control laws and regulations and follow the procedures required by such laws and regulations.
10. It is the responsibility of the buyer or distributor of California Eastern Laboratories, who distributes, disposes of, or otherwise places the Renesas Electronics product with a third party, to notify such third party in advance of the contents and conditions set forth in this document, California Eastern Laboratories and Renesas Electronics assume no responsibility for any losses incurred by you or third parties as a result of unauthorized use of Renesas Electronics products.
11. This document may not be reproduced or duplicated in any form, in whole or in part, without prior written consent of California Eastern Laboratories.
12. Please contact a California Eastern Laboratories sales office if you have any questions regarding the information contained in this document or Renesas Electronics products, or if you have any other inquiries.

NOTE 1: "Renesas Electronics" as used in this document means Renesas Electronics Corporation and also includes its majority-owned subsidiaries.

NOTE 2: "Renesas Electronics product(s)" means any product developed or manufactured by or for Renesas Electronics.

NOTE 3: Products and product information are subject to change without notice.

CEL Headquarters • 4590 Patrick Henry Drive, Santa Clara, CA 95054 • Phone (408) 919-2500 • www.cel.com

For a complete list of sales offices, representatives and distributors,
Please visit our website: www.cel.com/contactus