

### FEATURES

- GALLIUM ARSENIDE ACTIVE DEVICES
- LOW DISTORTION
- LOW NOISE FIGURE  
(6.4 dB TYP at 860 MHz)
- HIGH RELIABILITY  
(FIT = 125 at heat sink temperature of 100°C, Report available)
- INDUSTRY COMPATIBLE PACKAGE

### DESCRIPTION

The MC-7852 is a GaAs hybrid integrated circuit designed to be used as the input device in CATV applications up to 860 MHz. This unit has a minimum gain of 18 dB at 860 MHz, and because it is a GaAs device, it has lower distortion and lower noise figure. Reliability is assured by NEC's stringent quality and process control procedures. Devices are assembled and tested using fully automated equipment to maximize the consistency in part to part performance. The MC-7852G features round connection pins and slightly different body dimensions for customers desiring these packaging dimensions.

### OUTLINE DIMENSIONS (Units in mm)

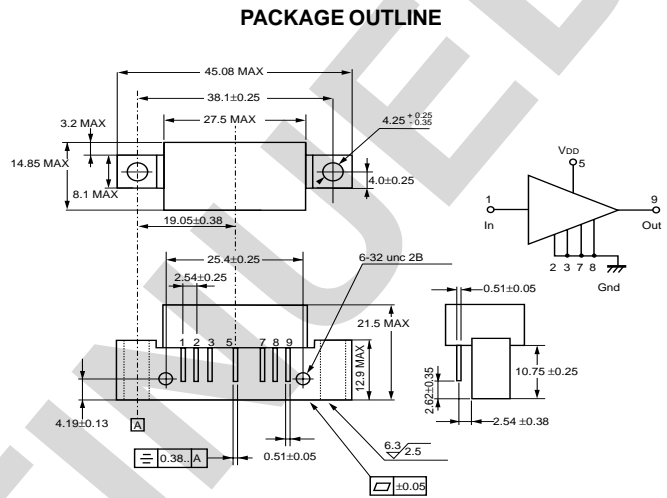

### ELECTRICAL CHARACTERISTICS (T<sub>case</sub> = 30 °C, V<sub>DD</sub> = 24 V, Z<sub>S</sub> = Z<sub>I</sub> = 75 Ω)

SYMBOLS	PART NUMBER	PARAMETERS	UNITS	MC-7852G			CONDITIONS
				MIN	TYP	MAX	
BW		Frequency Range	MHz	50		860	
GA		Gain	dB	18.0		19.5	f = 860 MHz
S		Gain Slope	dB	0		2.0	50 to 860 MHz
Gf		Gain Flatness	dB			1.0	50 to 860 MHz; Peak to Valley
S11		Input Return Loss	dB	18.0			50 to 160 MHz
			dB	17.0			160 to 320 MHz
			dB	16.0			320 to 640 MHz
			dB	14.5			640 to 860 MHz
S22		Output Return Loss	dB	18.0			50 to 160 MHz
			dB	17.0			160 to 320 MHz
			dB	16.0			320 to 640 MHz
			dB	14.5			640 to 860 MHz
S12		Reverse Isolation	dB	30			50 to 860 MHz
CTB		Composite Triple Beat, 110 Channels	dB		-59	-55	V <sub>OUT</sub> = 44 dBmV/ch
CSO		Composite Second Order, 110 Channels	dB		-62	-55	V <sub>OUT</sub> = 44 dBmV/ch
XMod		Cross Modulation, 110 Channels	dB		-62	-55	V <sub>OUT</sub> = 44 dBmV/ch
IDD		DC Current	mA		210	240	
NF		Noise Figure	dB		5.7	6.5	50 MHz
			dB		6.4	7.0	860 MHz

**ABSOLUTE MAXIMUM RATINGS<sup>1</sup>** (T<sub>CASE</sub> = 30 °C)

SYMBOLS	PARAMETERS	UNITS	RATINGS
V <sub>DD</sub>	Supply Voltage	V	30
V <sub>I</sub>	Input Voltage (Single Tone)	dBmV	65
T <sub>OP</sub>	Operating Temperature	°C	-30 to +100
T <sub>STG</sub>	Storage Temperature	°C	-40 to +100

Note:

1. Operation in excess of any one of these parameters may result in permanent damage.

**TYPICAL SCATTERING PARAMETERS**

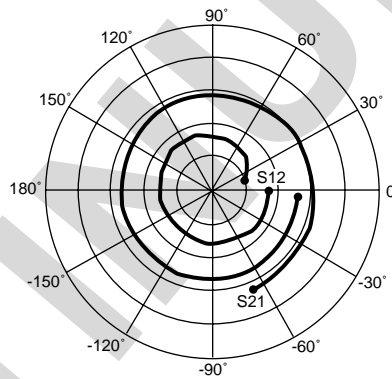
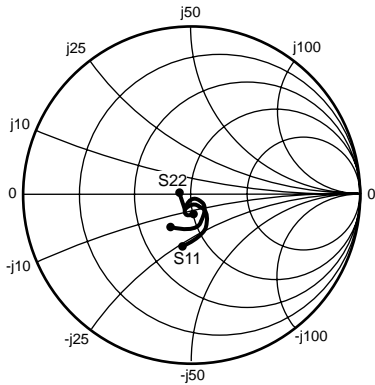

S<sub>21</sub> MAG:  
3.0/DIV., 15.00 FS  
S<sub>12</sub> MAG:  
0.01/DIV., 0.05 FS

V<sub>DD</sub> = 24 V

FREQUENCY (MHz)	S <sub>11</sub>		S <sub>21</sub>		S <sub>12</sub>		S <sub>22</sub>	
	MAG	ANG	MAG	ANG	MAG	ANG	MAG	ANG
50	0.052	-83.06	7.805	-2.112	0.017	-0.954	0.068	-176.60
100	0.057	-82.82	7.913	-29.080	0.017	-22.940	0.056	-163.50
150	0.071	-84.93	7.957	-51.100	0.017	-42.330	0.056	-143.70
200	0.085	-86.97	7.998	-71.670	0.016	-60.760	0.061	-133.30
250	0.099	-88.97	8.047	-91.690	0.016	-79.260	0.070	-125.10
300	0.113	-88.18	8.078	-111.600	0.016	-97.140	0.076	-117.30
350	0.123	-91.37	8.095	-131.800	0.015	-115.900	0.081	-118.10
400	0.133	-93.68	8.125	-151.100	0.015	-134.100	0.086	-115.50
450	0.132	-99.58	8.182	-171.100	0.015	-152.800	0.079	-119.90
500	0.129	-104.90	8.250	169.100	0.016	-171.200	0.070	-124.00
550	0.113	-107.80	8.333	149.000	0.016	170.500	0.050	-124.50
600	0.085	-110.10	8.431	128.600	0.016	153.400	0.023	-113.50
650	0.065	-97.46	8.522	108.200	0.017	136.900	0.031	-43.19
700	0.058	-68.52	8.575	87.710	0.017	120.900	0.063	-24.66
750	0.089	-53.94	8.675	67.150	0.017	105.200	0.104	-37.34
800	0.131	-52.90	8.836	46.370	0.016	90.700	0.141	-50.31
850	0.174	-58.69	9.042	25.010	0.016	75.670	0.170	-67.88
900	0.225	-70.76	9.312	3.054	0.015	60.340	0.193	-85.25
950	0.247	-83.43	9.481	-20.500	0.014	43.050	0.201	-97.83
1000	0.289	-92.15	9.452	-43.320	0.012	29.900	0.224	-112.00
1050	0.321	-100.70	9.657	-66.730	0.010	14.310	0.220	-125.10

EXCLUSIVE NORTH AMERICAN AGENT FOR **NEC** RF, MICROWAVE & OPTOELECTRONIC SEMICONDUCTORS

**CEL** CALIFORNIA EASTERN LABORATORIES • Headquarters • 4590 Patrick Henry Drive • Santa Clara, CA 95054-1817 • (408) 988-3500 • Telex 34-6393 • FAX (408) 988-0279  
24-Hour Fax-On-Demand: 800-390-3232 (U.S. and Canada only) • Internet: <http://WWW.CEL.COM>

DATA SUBJECT TO CHANGE WITHOUT NOTICE

05/17/2000