

# Machine Sync Supplemental Antenna

MPPC10118



**JOHN DEERE**

## INSTALLATION INSTRUCTIONS

### Machine Sync Supplemental Antenna

PFP24165 21JUL23 (ENGLISH)

**John Deere Ag Management Solutions**  
**PFP24165 (21JUL23)**

PRINTED IN U.S.A.  
COPYRIGHT © 2023  
DEERE & COMPANY

Moline, Illinois

All rights reserved.

A John Deere ILLUSTRATION™ Manual

PFP24165-19-21JUL23

PROOF PROOF

## Download Instructions

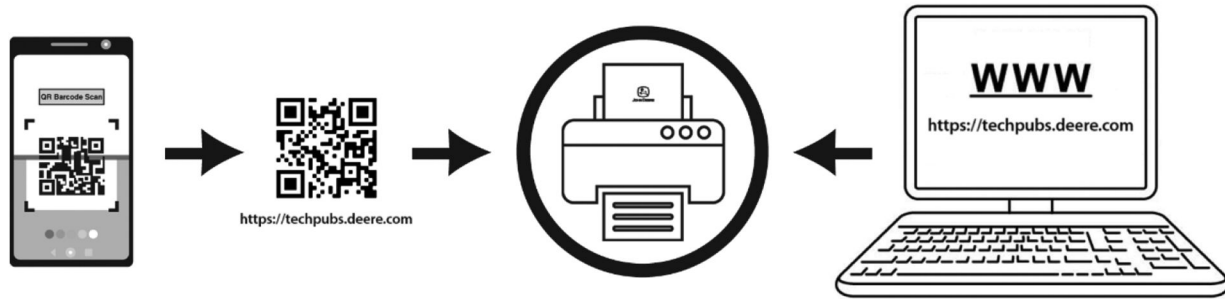

Instructions, manuals, and other documents may be downloaded at [www.techpubs.deere.com](http://www.techpubs.deere.com). Scanning the QR code on a mobile device will route to the site automatically.

Les instructions, les manuels et autres documents peuvent être téléchargés à cette adresse: [www.techpubs.deere.com](http://www.techpubs.deere.com). Scanner le QR code via un appareil mobile mène automatiquement au site.

Istruzioni, manuali e altri documenti possono essere scaricati su [www.techpubs.deere.com](http://www.techpubs.deere.com). La scansione del codice QR su un dispositivo portatile indirizza automaticamente al sito.

Anleitungen, Handbücher und andere Dokumente können unter [www.techpubs.deere.com](http://www.techpubs.deere.com) heruntergeladen werden. Durch Scannen des QR-Codes mit einem Mobilgerät wird man automatisch zur Webseite weitergeleitet.

Las instrucciones, los manuales y otros documentos se pueden descargar en [www.techpubs.deere.com](http://www.techpubs.deere.com). Al escanear el código QR en un dispositivo móvil, se abrirá automáticamente el sitio web.

Instruções, manuais e outros documentos podem ser baixados em [www.techpubs.deere.com](http://www.techpubs.deere.com). A leitura do código QR em um dispositivo móvel levará você automaticamente para o site.

Инструкции, руководства и другие документы можно загрузить на странице [www.techpubs.deere.com](http://www.techpubs.deere.com). Сканирование QR-кода на мобильном устройстве будет автоматически отправлять на сайт.

TS1746—UN—26APR21

DX.DOWNLOADINSTRUCTIONS,AT -19-27APR21-1/1

## Check Status of Installation Instructions

**IMPORTANT:** Before starting installation work, check if there is a newer version of

the Installation Instructions available in the Technical Information Store. See <https://techpubs.deere.com>.

GS75158,000CA63 -19-05OCT21-1/1

## Trademarks

Trademarks	
AutoTrac™	Trademark of Deere & Company
AutoTrac™ Turn Automation	Trademark of Deere & Company
CommandARM™	Trademark of Deere & Company
GreenStar™	Trademark of Deere & Company
iGuide™	Trademark of Deere & Company
iTEC™ Pro	Trademark of Deere & Company
RowSense™	Trademark of Deere & Company
Service ADVISOR™	Trademark of Deere & Company

bvmsit,1679897959849 -19-27MAR23-1/1

## Recognize Safety Information

This is a safety-alert symbol. When you see this symbol on your machine or in this manual, be alert to the potential for personal injury.

Follow recommended precautions and safe operating practices.



T81389 —UN—28JUN13

DX,ALERT -19-03OCT22-1/1

## Understand Signal Words

**DANGER;** The signal word DANGER indicates a hazardous situation which, if not avoided, will result in death or serious injury.

**WARNING;** The signal word WARNING indicates a hazardous situation which, if not avoided, could result in death or serious injury.

**CAUTION;** The signal word CAUTION indicates a hazardous situation which, if not avoided, could result in minor or moderate injury. CAUTION may also be used to alert against unsafe practices associated with events which could lead to personal injury.

A signal word—DANGER, WARNING, or CAUTION—is used with the safety-alert symbol. DANGER identifies the most serious hazards. DANGER or WARNING safety signs are located near specific hazards. General



**▲ WARNING**

**▲ CAUTION**

precautions are listed on CAUTION safety signs. CAUTION also calls attention to safety messages in this manual.

TS187 —19—30SEP88

DX,SIGNAL -19-05OCT16-1/1

### Follow Safety Instructions

Carefully read all safety messages in this instruction. Read the product operators manual for operating instructions and safety messages.

Do not let anyone operate machine until they have been properly instructed. (The operator's manual is available from the Service ADVISOR application.)

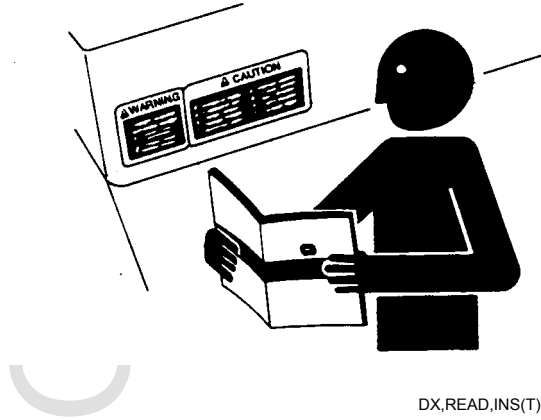

TS201 —UN—15APR13

DX,READ,INS(T) -19-04APR22-1/1

### Replace Safety Signs

Replace missing or damaged safety signs. See the machine operator's manual for correct safety sign placement.

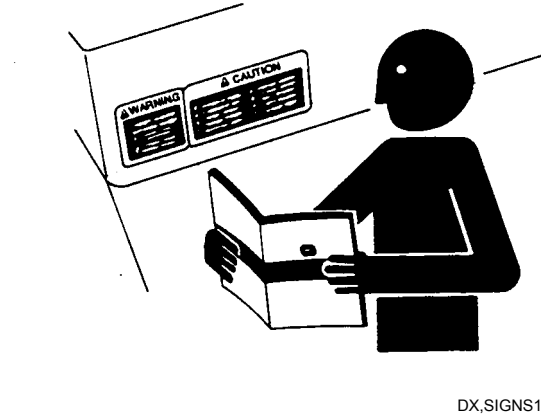

TS201 —UN—15APR13

DX,SIGNS1 -19-04JUN90-1/1

P  
R  
O  
O  
F

## Practice Safe Maintenance

Understand service procedure before doing work. Keep area clean and dry.

Never lubricate, service, or adjust machine while it is moving. Keep hands, feet, and clothing away from power-driven parts. Disengage all power and operate controls to relieve pressure. Lower equipment to the ground. Stop the engine. Remove the key. Allow machine to cool.

Securely support any machine elements that must be raised for service work.

Keep all parts in good condition and properly installed. Fix damage immediately. Replace worn or broken parts. Remove any buildup of grease, oil, or debris.

On self-propelled equipment, disconnect battery ground cable (-) before making adjustments on electrical systems or welding on machine.

On towed implements, disconnect wiring harnesses from tractor before servicing electrical system components or welding on machine.

Falling while cleaning or working at height can cause serious injury. Use a ladder or platform to easily reach each location. Use sturdy and secure footholds and handholds.



TS218 —UN—23AUG88

DX,SERV -19-28FEB17-1/1

## Use Steps and Handholds Correctly

Prevent falls by facing the machine when getting on and off. Maintain 3-point contact with steps, handholds, and handrails.

Use extra care when mud, snow, or moisture present slippery conditions. Keep steps clean and free of grease or oil. Never jump when exiting machine. Never mount or dismount a moving machine.

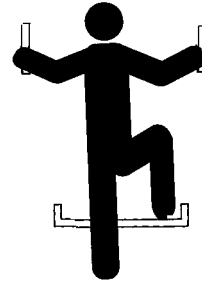

T133468 —UN—15APR13

DX,WW,MOUNT -19-12OCT11-1/1

ROOF

## Handle Electronic Components and Brackets Safely

Falling while installing or removing electronic components mounted on equipment can cause serious injury. Use a ladder or platform to easily reach each mounting location. Use sturdy and secure footholds and handholds. Do not install or remove components in wet or icy conditions.

If installing or servicing a RTK base station on a tower or other tall structure, use a certified climber.

If installing or servicing a global positioning receiver mast used on an implement, use proper lifting techniques and wear proper protective equipment. The mast is heavy and can be awkward to handle. Two people are required when mounting locations are not accessible from the ground or from a service platform.



TS249—UN—23AUG88

DX,WW,RECEIVER -19-24AUG10-1/1

## Electrical System — General Instructions on Safety

**CAUTION: Avoid Electrical Shock. Before working on the electrical system, always disconnect battery ground cable (-).**

*NOTE: Refer also to the Technical Manual before installing, removing or adjusting components.*

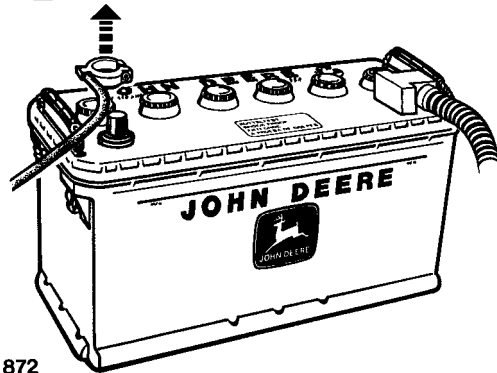

LX 000872

LX000872—UN—19SEP94

OUO6043,0000313 -19-12MAY23-1/1

## Use Technical Manuals

When performing the work described in this instruction, use relevant Technical Manuals for additional service instruction.

Carefully read and comply with safety messages and cautions presented throughout the text.

Both diagnostic and repair technical manuals are concise guides for specific equipment. They are on-the-job instructions containing vital information to diagnose, analyze, test, and repair the equipment.



ZX1051364—UN—20NOV12

OUO6043,0000314 -19-16OCT13-1/1

### Park Machine Safely

Before working on the machine:

- Lower all equipment to the ground.
- Stop the engine and remove the key.
- Disconnect the battery ground strap.
- Hang a "DO NOT OPERATE" tag in operator station.

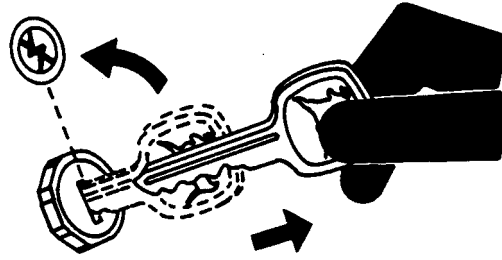

TS230—UN—24MAY89

DX,PARK -19-04JUN90-1/1

COF  
PROOF



## Instruction for Wire Routing

**IMPORTANT: Disconnect battery ground cable during installation. Connecting power during installation may result in damage to equipment.**

The term harnesses is used to mean all electrical leads and cables, bundled and unbundled.

Only use harnesses on intended platforms. Do not modify harness in any way.

Do not bend harnesses more than the recommended bend radius.

When installing harness, use tie bands and dual tie bands to attach harness to frame at least every 30 cm (12 in). Follow existing harnesses as much as possible and use the following guidelines.

Harness wires must be covered with tape or flexible sleeves up to the back of connectors and should not be visible.

Do not allow harnesses to contact or be attached to:

- Lines and hoses with high vibration forces or pressure spikes.
- Lines and hoses that carry hot fluids beyond harness components specifications.
- Lines and hoses that carry fuel or oil.
- If routing harnesses away from lines or hoses is unavoidable, use dual tie bands and ensure that enough distance is maintained.

Avoid contact with any sharp edge or abrading surfaces, such as (but not limited to):

- Sheared or flame cut edges.
- Edges of machined surfaces.
- Fastener threads or cap screw heads.
- Ends of adjustable hose clamps.
- Wire exiting conduit without protection, either ends or side of conduit.
- Hose and tube fittings.

When routing, do not allow harnesses to:

- Hang below machine or implement.

- Have the potential to become damaged due to exposure to exterior environment (for example, tree limbs, debris, or attachments).
- Have contact or placed in areas with machine components which develop temperatures higher than the temperature rating of harness components.
- Be near hot temperatures beyond harness components specifications without appropriate shielding or protection.

Allow sufficient clearance from the machine component operational zones including, but not limited to:

- Drive shafts, universal joints, or hitches (for example, 3-point hitch).
- Pulleys, gears, or sprockets.
- Deflection or backlash of belts and chains.
- Adjustment zones of adjustable brackets.
- Changes of position in steering or suspension systems.
- Moving linkages, cylinders, articulation joints, or attachments.
- Ground engaging components.

When routing harness sections that move during machine operation:

- Allow sufficient length for free movement without interference to prevent pulling, pinching, catching, or rubbing, especially in articulation and pivot points.
- Clamp harnesses securely to force controlled movement to occur in the desired harness section.
- Avoid sharp twisting or flexing of harnesses in short distances.
- Do not place connectors or splices in sections that move.

Protect harnesses from:

- Foreign objects such as rocks that may fall or be thrown by machine or implement.
- Buildup of dirt, mud, snow, ice, or liquid submersion.
- Tree limbs, brush, or debris.
- Damage where service personnel or operators might step or use as a grab bar.
- Damage when passing through metal structures.
- High-pressure wash.

RW00482,0000916 -19-17OCT19-1/1

### Operate Guidance Systems Safely

Do not use guidance systems on roadways. Always turn off (disable) guidance systems before entering a roadway. Do not attempt to turn on (activate) a guidance system while transporting on a roadway.

Guidance systems are intended to aid the operator in performing field operations more efficiently. The operator is always responsible for the machine path. Guidance systems do not automatically detect or prevent collisions with obstacles or other machines.

Guidance Systems include any application that automates machine steering. This includes, but may not be limited to AutoTrac, iGuide, iTEC Pro, AutoTrac Turn Automation, AutoTrac Universal (ATU), RowSense, and Machine Sync.

To prevent injury to the operator and bystanders:

- Never get on or off a moving machine.

- Verify the machine, implement, and guidance system are set up correctly.
  - If using iTEC Pro or AutoTrac Turn Automation, verify accurate boundaries have been defined.
  - If using Machine Sync, verify the follower's home point is calibrated with sufficient space between the machines.
- Remain alert and pay attention to the surrounding environment.
- Take control of the steering wheel, when necessary, to avoid field hazards, bystanders, equipment, or other obstacles.
- Stop operation if poor visibility conditions impair your ability to operate the machine or identify people or obstacles in the machine path.
- Consider field conditions, visibility, and machine configuration when selecting machine speed.

bvmsit,1679900281488 -19-27MAR23-1/1

### Use Seat Belt Properly

Avoid crushing injury or death during rollover.

This machine is equipped with a rollover protective structure (ROPS). USE a seat belt when you operate with a ROPS.

- Hold the latch and pull the seat belt across the body.
- Insert the latch into the buckle. Listen for a click.
- Tug on the seat belt latch to make sure that the belt is securely fastened.
- Snug the seat belt across the hips.

Replace entire seat belt if mounting hardware, buckle, belt, or retractor show signs of damage.

Inspect seat belt and mounting hardware at least once a year. Look for signs of loose hardware or belt damage, such as cuts, fraying, extreme or unusual wear,

discoloration, or abrasion. Replace only with replacement parts approved for your machine. See your John Deere dealer.

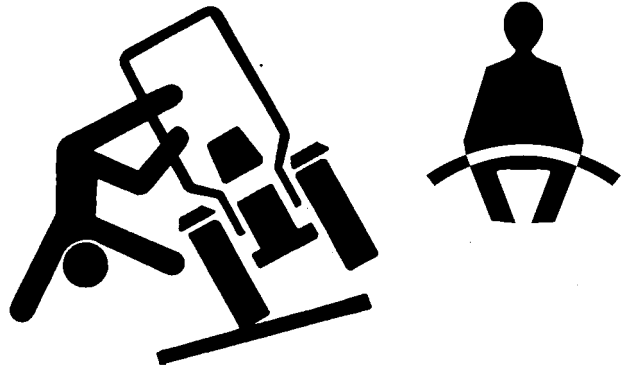

TS1729 —UN—24MAY13

DX,ROPS1 -19-22AUG13-1/1

### Avoid Exposure to High Radio Frequency Fields

Prevent injury from exposure to high radio frequency fields at the MTG antenna. Do not touch the MTG antenna while the system is transmitting. Always disconnect power to the antenna before installing or servicing.

The MTG antenna should always be separated from the operator or nearby persons by a minimum distance of 20 cm (8 in.)



PC12632 —UN—04JUN10

CZ76372,0000544 -19-30NOV12-1/1

**Antenna Information**

Additional Antenna Information

PFP23758

WiFi/BT 2.4 GHz Antenna

Wireless 2.4: 2400-2500 MHz Frequency

Bluetooth: 2402-2480 MHz Frequency

50  $\Omega$  Required Impedance

5 dBi Maximum Permissible Gain

LMR 240 UF RF Cable

50  $\Omega$  Impedance

6.0 GHz Maximum Operating Frequency

Cable Loss: 3.2 dBi (at 18 feet and at 2.5 GHz)

ck71239,1689960779324 -19-21JUL23-1/1

PROOF  
PROOF

Parts List

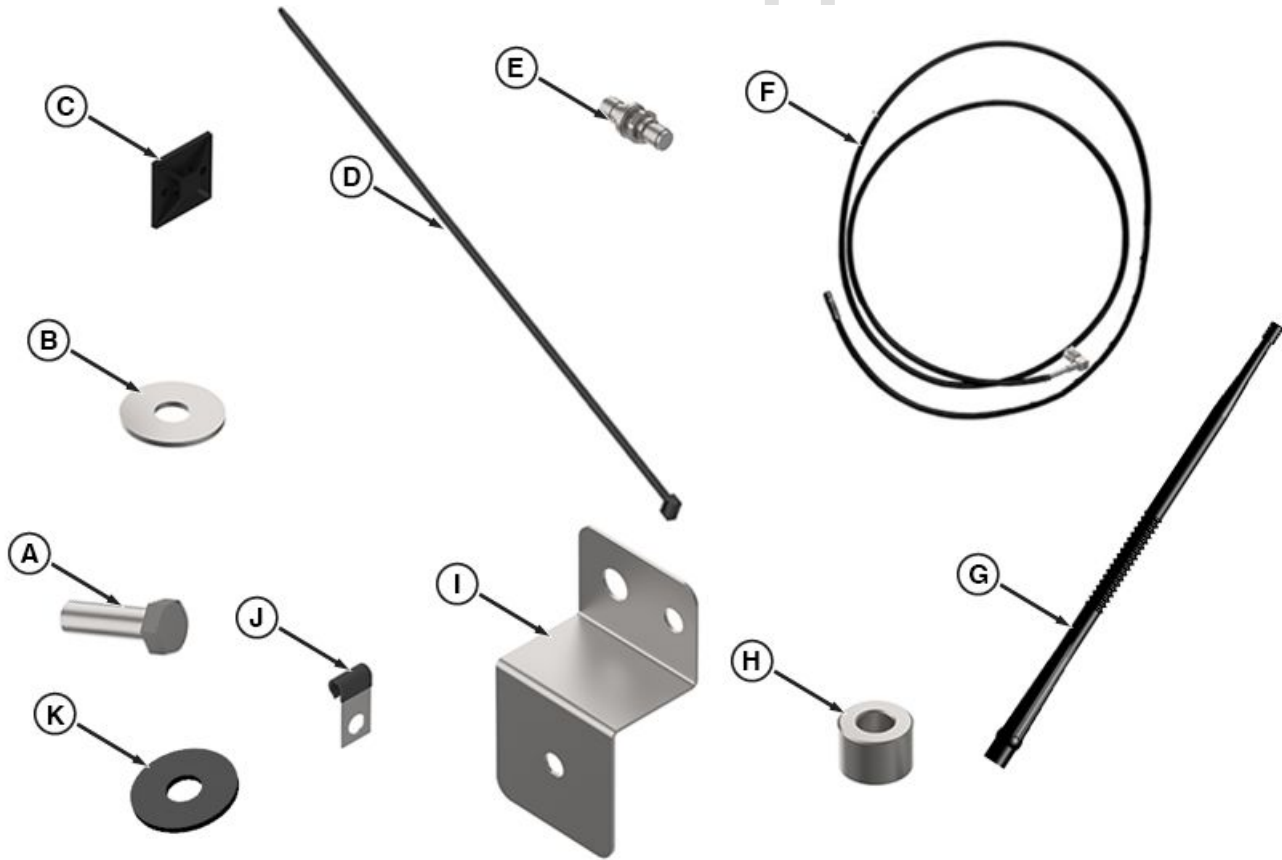

APY80376R—UN—18APR23

MPPC10118			
Position	Part Number	Description	Quantity
A	19M7397	Cap Screw M16 x 50 mm	1
B	24M7315	Washer 17 x 50 x 3 mm	2
C	A87105	Adhesive Anchor	6
D	H77698	Tie Band	20
E	PFP11510	Coax Adapter	1
F	PFP23754	Antenna Cable	1
G	PFP23758	Antenna	1
H	R115277	Spacer	1
I	R339834	Bracket	1
J	T32231	P-Clamp	6
K	L200226	Rubber Washer	1

bvmsit,1680106964188 -19-27APR23-1/1

## Table of Contents

### Harvesters:

- Install Antenna—Combine Harvester
- Install Antenna—Self-Propelled Forage Harvester

### Tractors:

- Install Antenna—Tractor (MY19 and Older)
- Install Antenna—Tractor (MY20+)

bvmsit,1680179723179 -19-31MAR23-1/1

## Install Antenna—Combine Harvester

1. Install O-ring into the coax adapter (A) groove.

A—O-ring

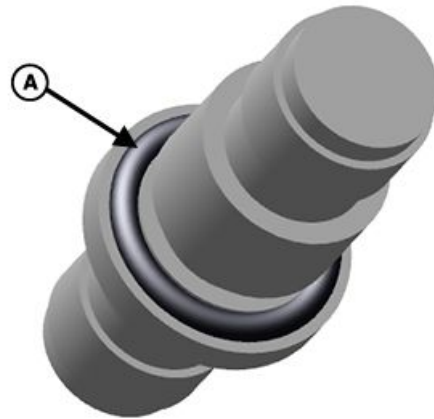

Coax Adapter

Continued on next page

bvmsit,1680107053593 -19-02MAY23-1/6

PC29055—UN—27APR23

2. Install coax adapter (A) to antenna bracket (B) using jam nut (C).

**NOTE:** Ensure that the coax adapter (A) face with the O-ring faces the upper side of the antenna bracket (B).

**Specification**

Jam Nut (C)—Torque.....15 N·m (133 lb·in)

**A—Coax Adapter**  
**B—Antenna Bracket**

**C—Jam Nut**

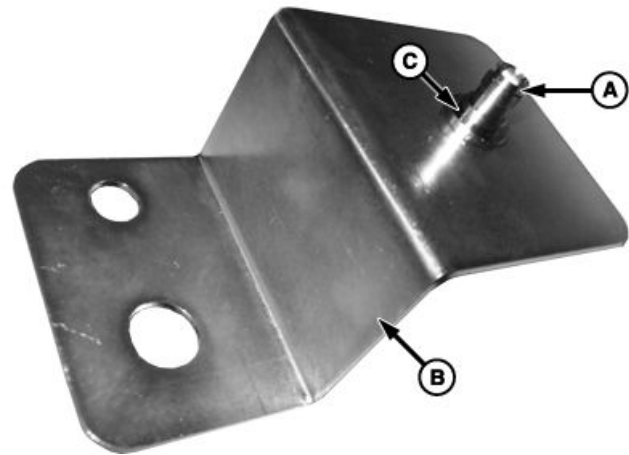

Antenna Bracket with Coax Adapter (Top View)

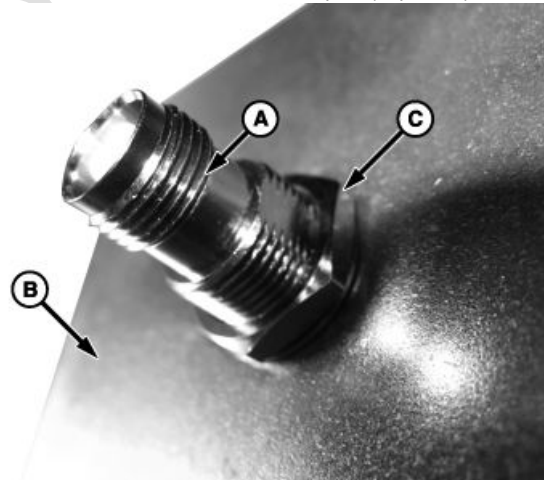

Antenna Bracket with Coax Adapter (Bottom View)

bvmsit,1680107053593 -19-02MAY23-2/6

PC14251—UN—15DEC11

PC14252—UN—15DEC11

3. Remove and retain left-hand cab lift cap screw (D).
4. Install hardware on cap screw (D) in the following order: metal washer (A), rubber washer (B), antenna bracket (C), metal washer (A), and rubber washer (B).

**A—Metal Washer (2 used)**  
**B—Rubber Washer (2 used)**

**C—Antenna Bracket**  
**D—Cab Lift Cap Screw**

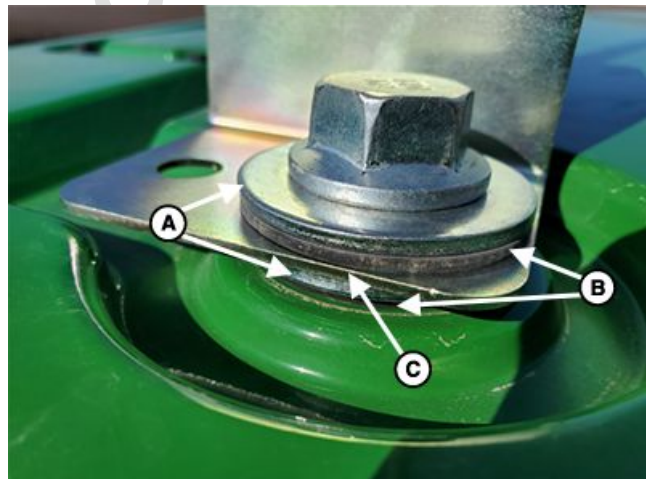

Left-Hand Cab Cap Screw Stackup

Continued on next page

bvmsit,1680107053593 -19-02MAY23-3/6

PC29012—UN—24APR23

5. Install antenna bracket (A) on the cab roof using cab lift cap screw (B). Tighten the cab lift cap screw (B).

*NOTE: If required, use the spacer and rubber washer to provide the clearance between the antenna bracket and cab roof. Ensure that the spacer, rubber washer, metal washer, and antenna bracket are placed over the cab roof opening before installing the cab lift cap screw.*

6. Install antenna (C) to the upper side of coax adapter (D) on the antenna bracket (A) as shown.
7. Connect antenna cable (E) to the lower side of coax adapter (D) as shown.

*NOTE: Thoroughly clean the surface before mounting the adhesive anchor on the machine.*

8. Route antenna cable (E) towards the left rear of the cab, across the back of the cab and down the right rear side of the cab. Secure antenna cable (E) to cab roof using the P-clamps (F) as shown.

*NOTE: Ensure that the antenna cable (E) is not tangled with any component on the machine.*

- |                      |                    |
|----------------------|--------------------|
| A—Antenna Bracket    | D—Coax Adapter     |
| B—Cab Lift Cap Screw | E—Antenna Cable    |
| C—Antenna            | F—P-Clamp (4 used) |

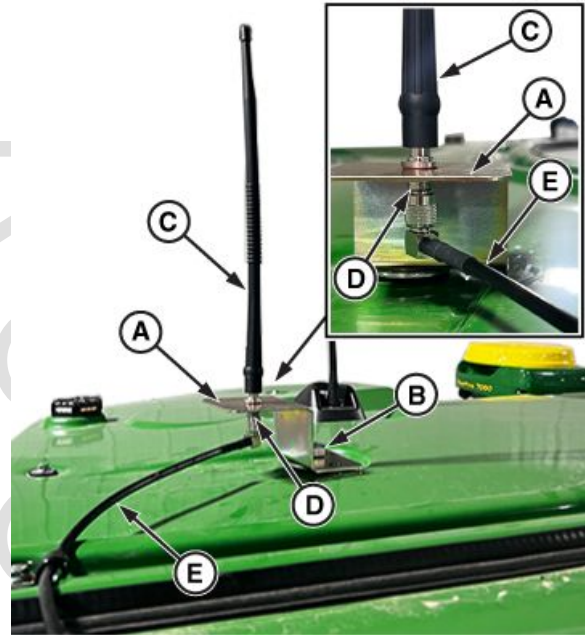

Antenna Bracket Installation

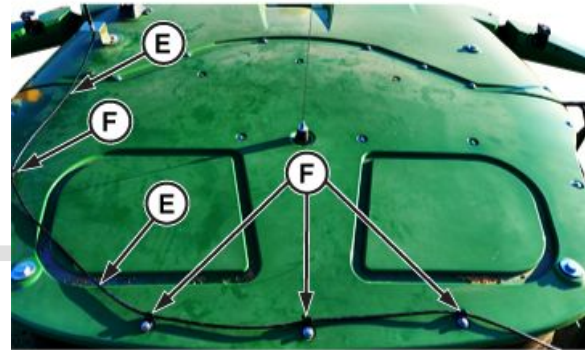

Antenna Cable Routing

Continued on next page

bvmsit,1680107053593 -19-02MAY23-4/6

APY80364 —UN—30MAR23

APY80365 —UN—29MAR23

- Open right-hand gull wing door (A).

*NOTE: Thoroughly clean the surface before mounting the adhesive anchor on the machine.*

- Route antenna cable behind the cab to the connector panel (B). Use the tie bands with edge clips (C) or adhesive anchor and tie band to secure the antenna cable to cab.
- Disconnect and remove the old antenna cable and antenna if installed on the machine.

**A—Right-Hand Gull Wing Door    C—Tie Band with Edge Clip**  
**B—Connector Panel**



*Gull Wing Door Opening*

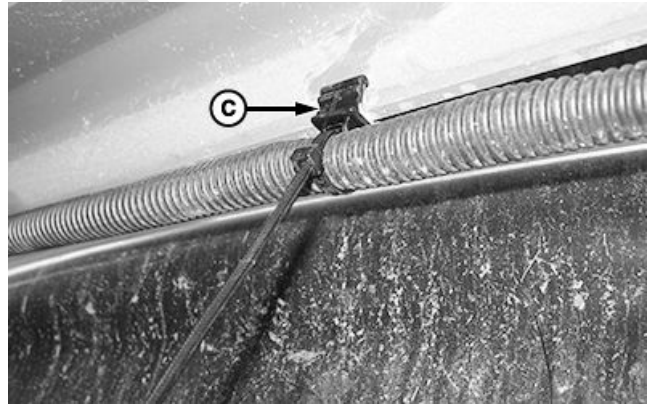

*Tie Band with Edge Clip Installation*

PC26166 —UN—28AUG18

PC26167 —UN—18DEC18

bvmsit,1680107053593 -19-02MAY23-5/6

- Connect antenna cable (A) to the bulkhead connector (B).
- Use tie bands to retain antenna cable to the machine harness.
- Secure excess antenna cable (A) with tie band at suitable location.

**A—Antenna Cable                      C—Connector Panel**  
**B—Bulkhead Connector**



*Antenna Cable Connection*

APY80366 —UN—29MAR23

bvmsit,1680107053593 -19-02MAY23-6/6



## Install Antenna—Self-Propelled Forage Harvester

**NOTE:** Position the antenna in line-of-sight of the follower's unloading position.

*If the leader is unloading on the left-hand side, place the antenna on the left-hand side of the machine.*

*If unloading from both sides of the machine, place the antenna in the middle of the rear crossbar.*

1. Install O-ring into the coax adapter (A) groove.
2. Install coax adapter (A) to antenna bracket (B) using jam nut (C).

**NOTE:** Ensure that the coax adapter (A) face with the O-ring faces the upper side of the antenna bracket (B).

### Specification

Jam Nut (C)—Torque..... 15 N·m (133 lb-in)

A—Coax Adapter                      C—Jam Nut  
 B—Antenna Bracket

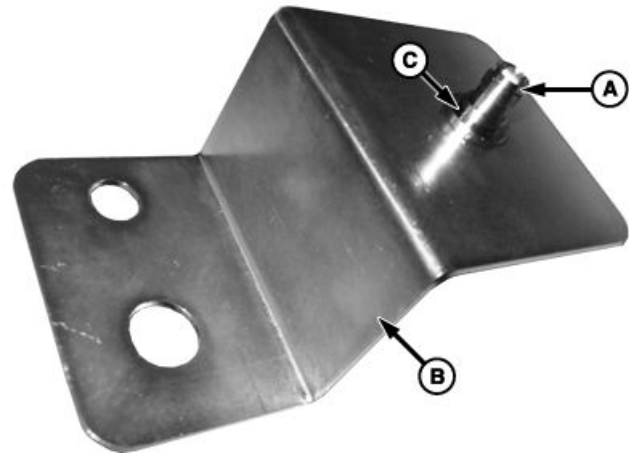

Antenna Bracket with Coax Adapter (Top View)

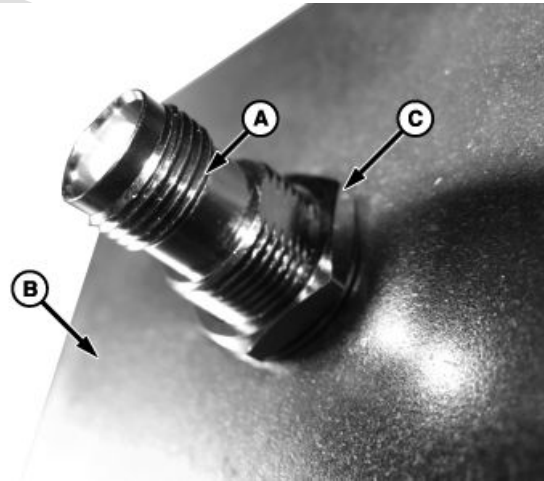

Antenna Bracket with Coax Adapter (Bottom View)

bvmsit,1680107053733 -19-02MAY23-1/6

PC14251—UN—15DEC11

PC14252—UN—15DEC11

3. Remove and retain left-hand cab lift cap screw.
4. Install hardware on cap screw (D) in the following order: metal washer (A), rubber washer (B), antenna bracket (C), metal washer (A), and rubber washer (B).

A—Metal Washer (2 used)              C—Antenna Bracket  
 B—Rubber Washer (2 used)            D—Cab Lift Cap Screw

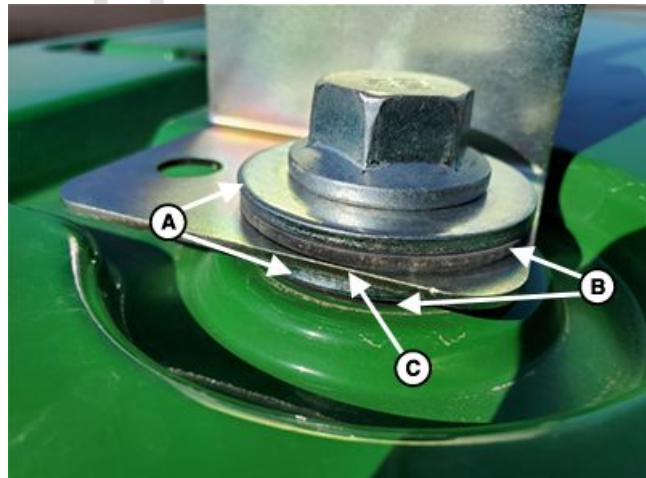

Left-Hand Cab Cap Screw Stackup

Continued on next page

bvmsit,1680107053733 -19-02MAY23-2/6

PC29012—UN—24APR23

5. Install antenna bracket (A) on the cab roof using cab lift cap screw (B). Tighten the cab lift cap screw (B).

*NOTE: If required, use the spacer and rubber washer to provide the clearance between the antenna bracket and cab roof. Ensure that the spacer, rubber washer, metal washer, and antenna bracket are placed over the cab roof opening before installing the cab lift cap screw.*

6. Install antenna (C) to the upper side of coax adapter (D) on the antenna bracket (A) as shown.
7. Connect antenna cable (E) to the lower side of coax adapter (D) as shown.

*NOTE: Thoroughly clean the surface before mounting the adhesive anchor on the machine.*

8. Route antenna cable (E) towards the left rear of the cab, across the back of the cab, and down the right rear side of the cab. Secure antenna cable (E) to cab roof using the P-clamps (F) and adhesive anchor (G) as shown.

*NOTE: Ensure that the antenna cable (E) is not tangled with any component on the machine.*

- |                      |                    |
|----------------------|--------------------|
| A—Antenna Bracket    | E—Antenna Cable    |
| B—Cab Lift Cap Screw | F—P-Clamp (4 used) |
| C—Antenna            | G—Adhesive Anchor  |
| D—Coax Adapter       |                    |

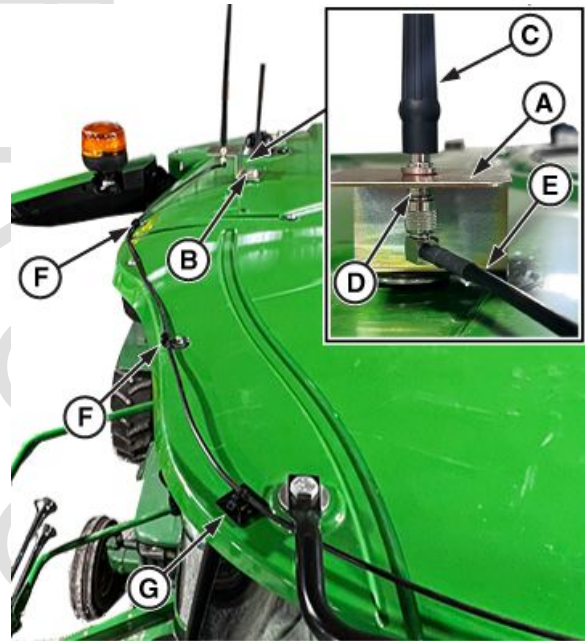

Antenna Bracket Installation

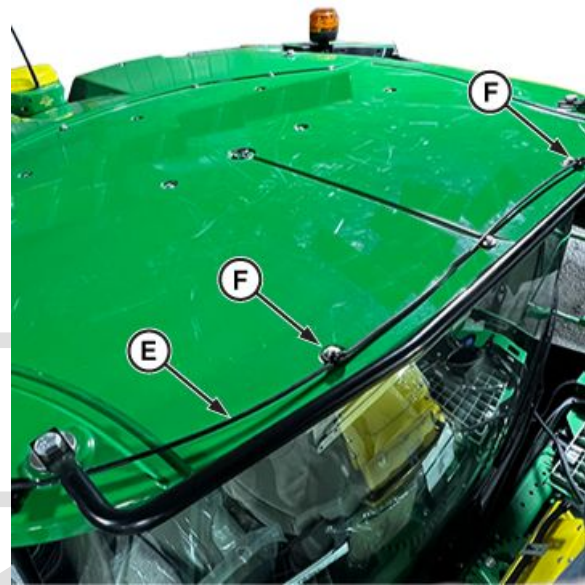

Antenna Cable Routing

Continued on next page

bvmsit,1680107053733 -19-02MAY23-3/6

APY80367 —UN—30MAR23

APY80368 —UN—29MAR23

**NOTE:** Thoroughly clean the surface before mounting the adhesive anchor on the machine.

9. Route antenna cable (A) along the left rear pillar of the cab. Secure antenna cable (A) to cab using adhesive anchors (B) as shown.

**A—Antenna Cable                      B—Adhesive Anchor (3 used)**

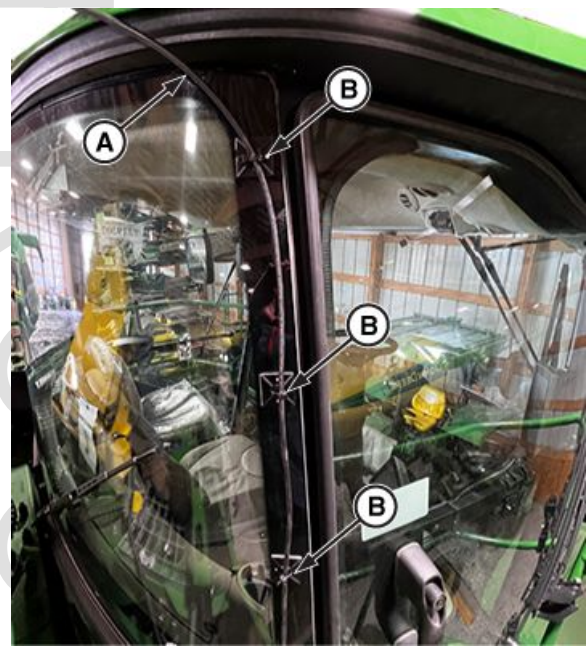

Antenna Cable Routing

bvmsit,1680107053733 -19-02MAY23-4/6

APY80369 —UN—29MAR23

10. Open the right-hand gull wing door (A).
11. Remove and retain cap screws (B) from the access panel (C) behind the cab.
12. Remove and retain the access panel (C).
13. Disconnect and remove the old antenna cable and antenna if installed on the machine.

**A—Right-Hand Gull Wing Door    C—Access Panel  
B—Cap Screw (3 used)**

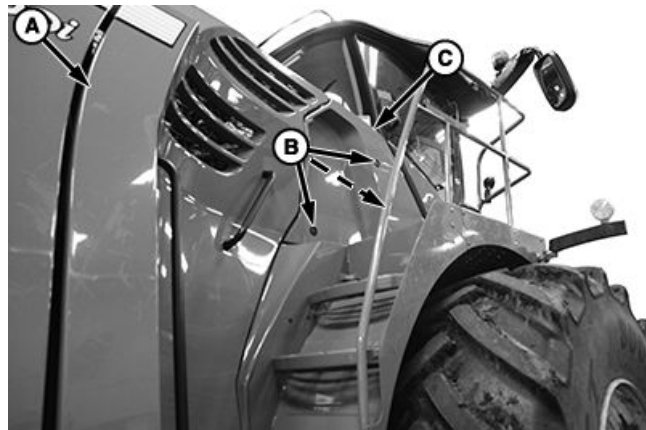

Gull Wing Door Opening

bvmsit,1680107053733 -19-02MAY23-5/6

PC28084 —UN—30JUL20

14. Connect antenna cable (A) to the front of the bulkhead connector (B).
15. Use tie bands to retain antenna cable to the machine harness.
16. Secure excess antenna cable (A) with tie band at suitable location.

**A—Antenna Cable                      B—Bulkhead Connector**

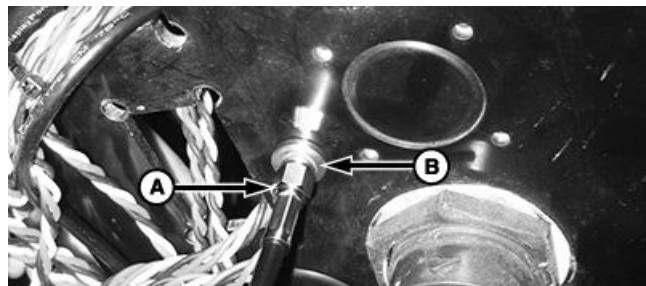

Antenna Cable Installation

bvmsit,1680107053733 -19-02MAY23-6/6

PC26640 —UN—17DEC18

### Install Antenna—Tractor (MY19 and Older)

*NOTE: If the tractor is used as a leader, install the antenna on the side of the machine that it unloads from.*

*If the tractor is used as a follower, install the antenna on the side of the machine closest to the leader.*

1. Install O-ring into the coax adapter (A) groove.

A—O-ring

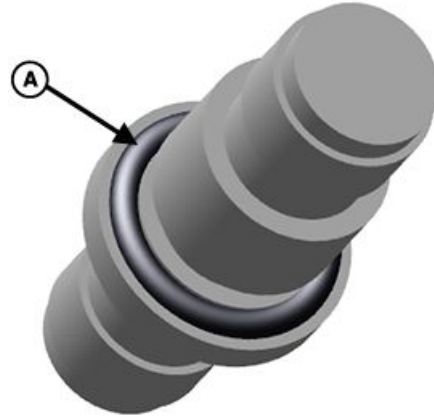

Coax Adapter

Continued on next page

bvmsit,1680060798840 -19-02MAY23-1/8

PC29055 —UN—27APR23

PROOF

2. Install coax adapter (A) to antenna bracket (B) using jam nut (C).

*NOTE: Ensure that the coax adapter (A) face with the O-ring faces the upper side of the antenna bracket (B).*

**Specification**

Jam Nut (C)—Torque.....15 N·m (133 lb·in)

**A—Coax Adapter**  
**B—Antenna Bracket**

**C—Jam Nut**

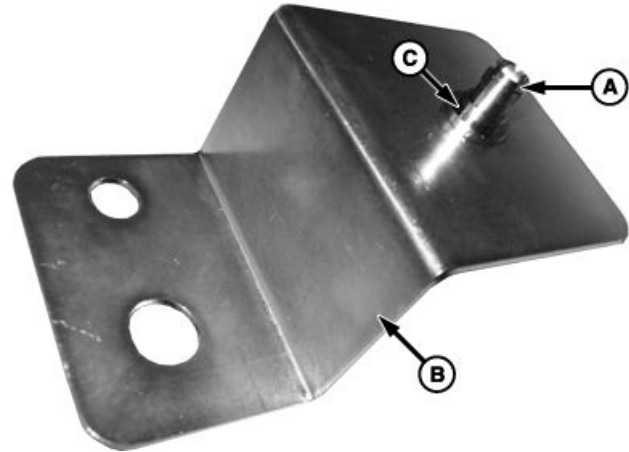

Antenna Bracket with Coax Adapter (Top View)

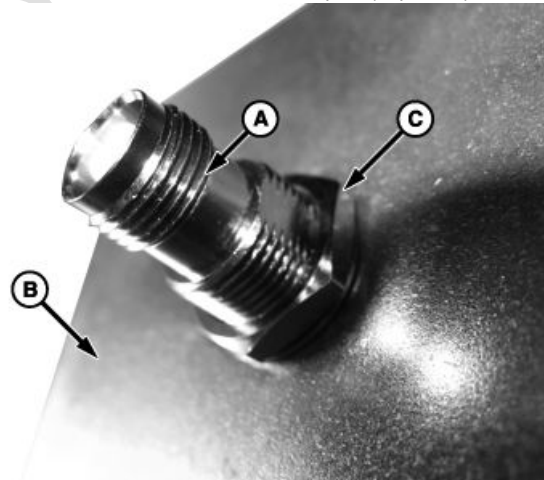

Antenna Bracket with Coax Adapter (Bottom View)

bvmsit,1680060798840 -19-02MAY23-2/8

PC14251—UN—15DEC11

PC14252—UN—15DEC11

3. Remove and retain right-hand cab lift cap screw (D).
4. Install hardware on cap screw (D) in the following order: metal washer (A), rubber washer (B), antenna bracket (C), metal washer (A), and rubber washer (B).

**A—Metal Washer (2 used)**  
**B—Rubber Washer (2 used)**

**C—Antenna Bracket**  
**D—Cab Lift Cap Screw**

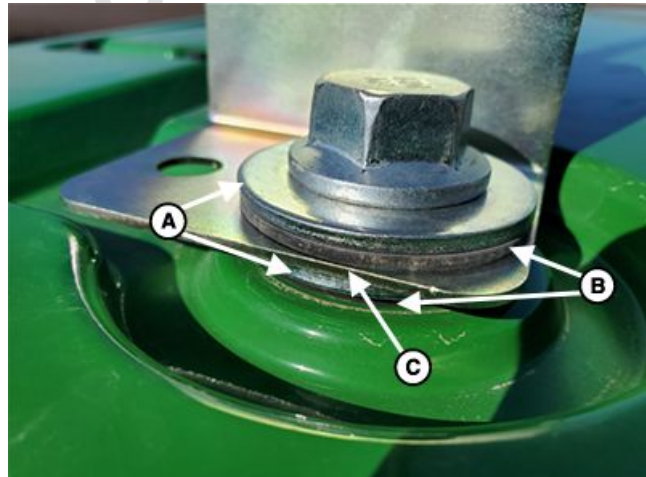

Right-Hand Cab Cap Screw Stackup

Continued on next page

bvmsit,1680060798840 -19-02MAY23-3/8

PC29012—UN—24APR23

5. Install antenna bracket (A).
  - a. Install antenna bracket (A) to cab roof using cab lift cap screw (B). Tighten the cab lift cap screw (B).

A—Antenna Bracket                      B—Cab Lift Cap Screw

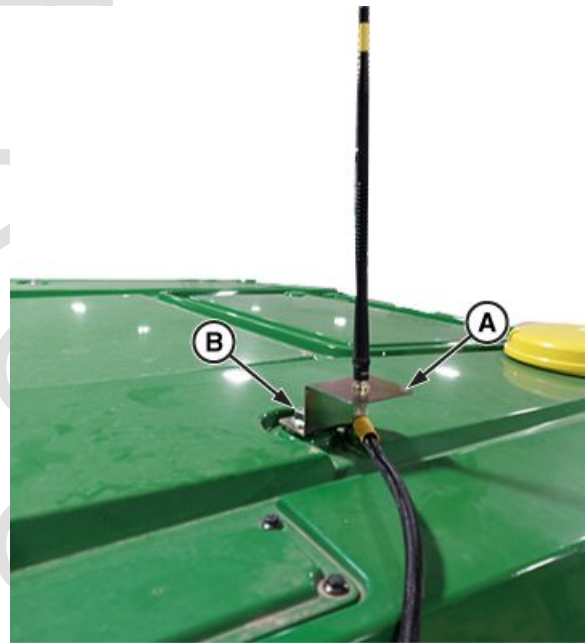

Antenna Bracket Installation

bvmsit,1680060798840 -19-02MAY23-4/8

APY80370—UN—29MAR23

- b. **For recessed cab lift screw:** Add a spacer to bottom of the rubber washer, metal washer (B) and antenna bracket stackup. Secure antenna bracket (C) to cab roof using cab lift cap screw (A).

*NOTE: Ensure that the rubber washer and spacer are sandwiched between the cab roof and the metal washer (B).*

A—Cab Lift Cap Screw                      C—Antenna Bracket  
 B—Metal Washer

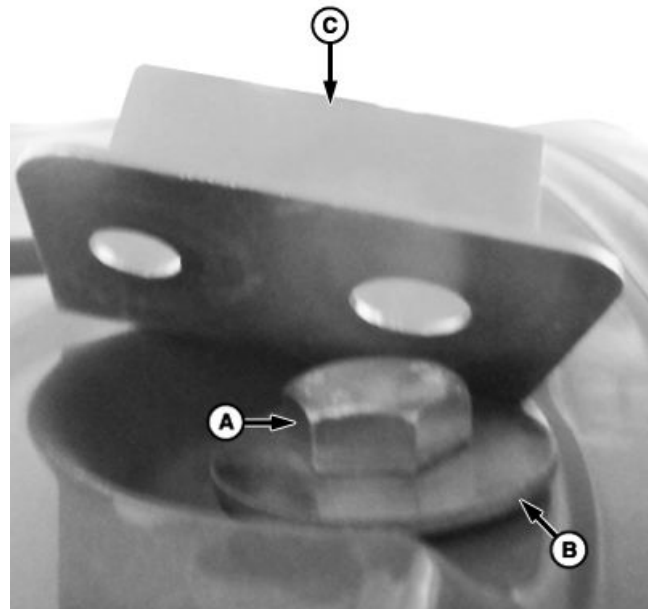

Antenna Bracket Installation

Continued on next page

bvmsit,1680060798840 -19-02MAY23-5/8

PC16328—UN—12DEC12

6. Install antenna (A) to the upper side of coax adapter (B) on the antenna bracket (C) as shown.
7. Connect antenna cable (D) to the lower side of coax adapter (B) as shown.

A—Antenna  
B—Coax Adapter

C—Antenna Bracket  
D—Antenna Cable

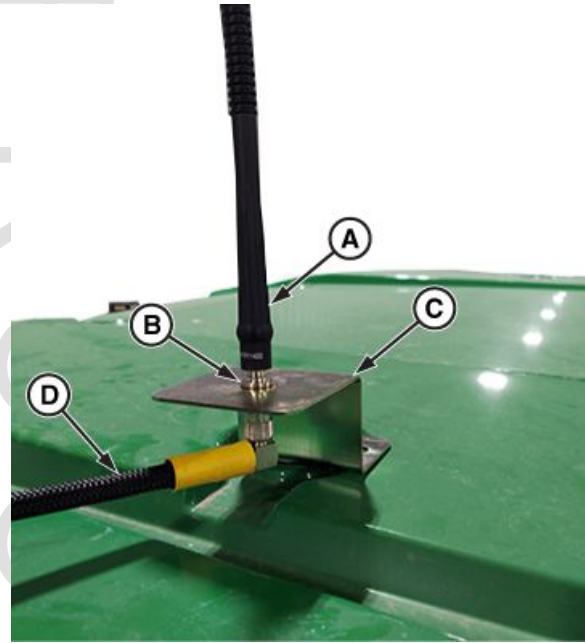

*Antenna Installation*

Continued on next page

bvmsit,1680060798840 -19-02MAY23-6/8

APY80371 —UN—29MAR23

P  
R  
O  
O  
F

**NOTE:** Thoroughly clean the surface before mounting the adhesive anchor on the machine.

8. Route the antenna cable (A):
  - a. To the right-hand rear corner of the cab.
  - b. Along the right-hand rear corner post to the window grommet (B).
  - c. Through the window grommet into the machine cab.

**NOTE:** The location of the JDLINK Modem within the cab or roof may vary depending on the model.

Refer to the machine Repair Manual to determine the JDLINK Modem location.

- d. Behind the cab interior cover (C) to the JDLINK Modem.

**NOTE:** Thoroughly clean the surface before mounting the adhesive anchor on the machine.

9. Attach the antenna cable (A) to the cab roof and corner post using tie bands and adhesive anchors. (P-clamps can also be used to secure antenna cable to cab roof.)

**NOTE:** Ensure that the antenna cable (A) is not tangled with any component on the machine.

- |                  |   |
|------------------|---|
| A—Antenna Cable  | C—Cab Upholstery                        |
| B—Window Grommet | D—Tie Band and Adhesive Anchor (4 used) |



Route Antenna Cable—Cab Roof

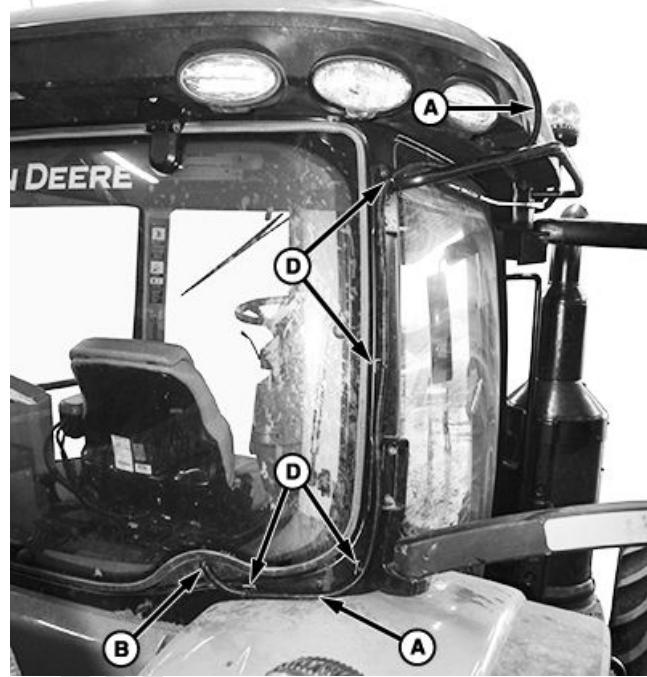

Route Antenna Cable—Corner Post

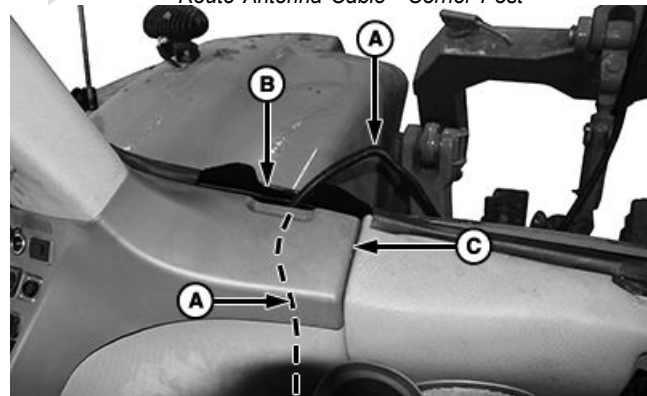

Route Antenna Cable—Cab

APY80377 —UN—31MAR23

PC28090 —UN—27AUG20

PC28091 —UN—12AUG20

Continued on next page

bvmsit,1680060798840 -19-02MAY23-7/8



10. Disconnect the existing wireless antenna connector (A) from the JDLink Modem.

11. Connect antenna cable (B) to JDLink Modem.

A—Wireless Antenna Connector

B—Antenna Cable

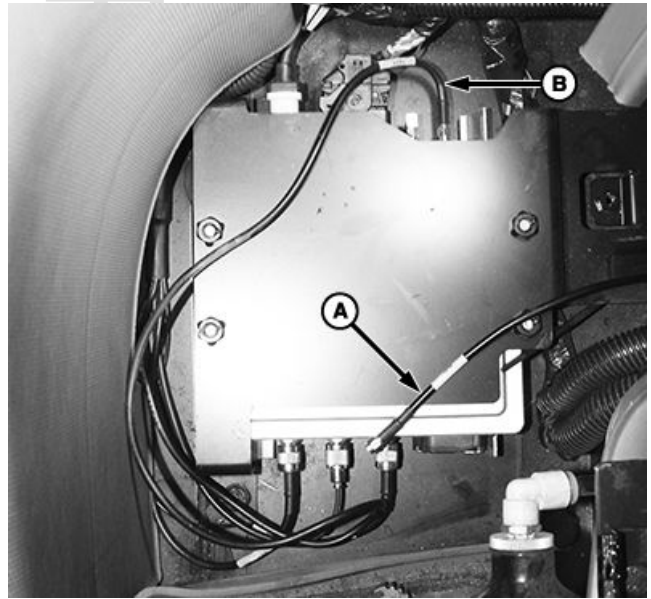

JDLink Modem Location

bvmsit,1680060798840 -19-02MAY23-8/8

PC28092—UN—31JUL20

### Install Antenna—Tractor (MY20+)

*NOTE: If the tractor is used as a leader, install the antenna on the side of the machine that it unloads from.*

*If the tractor is used as a follower, install the antenna on the side of the machine closest to the leader.*

1. Install O-ring into the coax adapter (A) groove.

A—O-ring

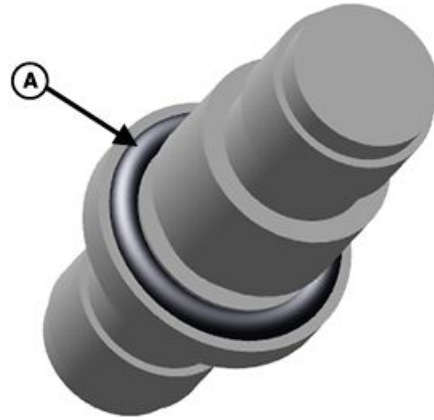

Coax Adapter

Continued on next page

bvmsit,1680071433915 -19-02MAY23-1/13

PC29055—UN—27APR23

2. Install coax adapter (A) to antenna bracket (B) using jam nut (C).

*NOTE: Ensure that the coax adapter (A) face with the O-ring faces the upper side of the antenna bracket (B).*

**Specification**

Jam Nut (C)—Torque.....15 N·m (133 lb·in)

**A—Coax Adapter**  
**B—Antenna Bracket**

**C—Jam Nut**

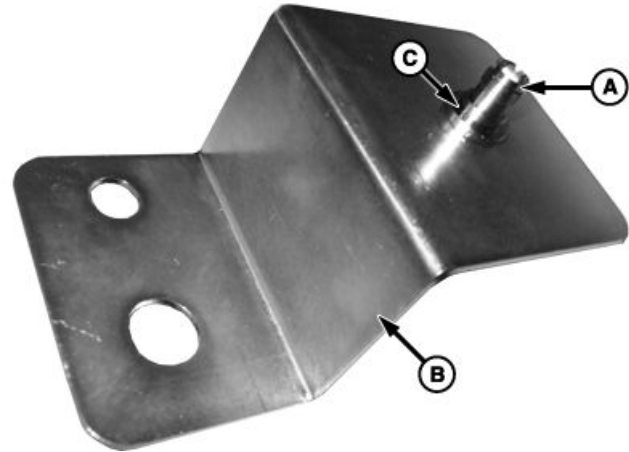

Antenna Bracket with Coax Adapter (Top View)

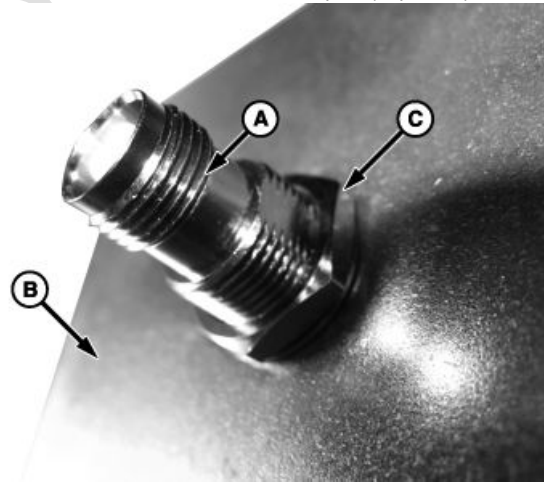

Antenna Bracket with Coax Adapter (Bottom View)

bvmsit,1680071433915 -19-02MAY23-2/13

PC14251—UN—15DEC11

PC14252—UN—15DEC11

3. Remove and retain right-hand cab lift cap screw.
4. Install hardware on cap screw (D) in the following order: metal washer (A), rubber washer (B), antenna bracket (C), metal washer (A), and rubber washer (B).
5. Install antenna bracket (A).

**A—Metal Washer (2 used)**  
**B—Rubber Washer (2 used)**

**C—Antenna Bracket**  
**D—Cab Lift Cap Screw**

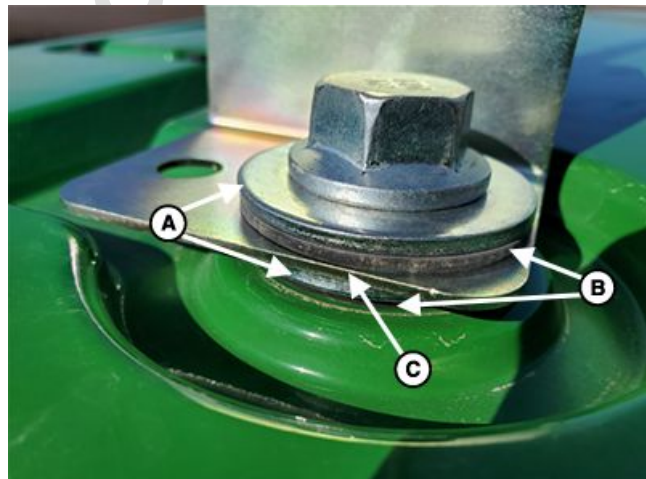

Right-Hand Cab Cap Screw Stackup

Continued on next page

bvmsit,1680071433915 -19-02MAY23-3/13

PC29012—UN—24APR23

- a. Install antenna bracket (A) to cab roof using cab lift cap screw (B). Tighten the cab lift cap screw (B).

A—Antenna Bracket

B—Cab Lift Cap Screw

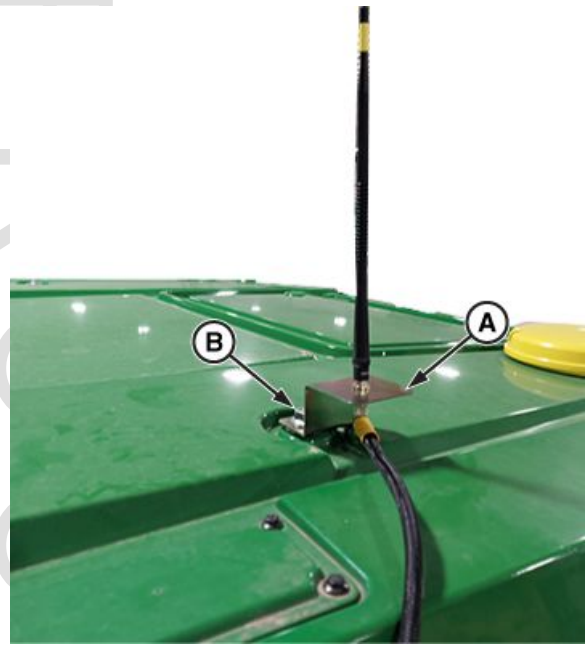

Antenna Bracket Installation

bvmsit,1680071433915 -19-02MAY23-4/13

APY80370—UN—29MAR23

- b. **For recessed cab lift cap screw:** Add a spacer to bottom of the rubber washer, metal washer (B) and antenna bracket stackup. Secure antenna bracket (C) to cab roof using cab lift cap screw (A).

*NOTE: Ensure that the rubber washer and spacer are sandwiched between the cab roof and the metal washer (B).*

A—Cab Lift Cap Screw  
B—Metal Washer

C—Antenna Bracket

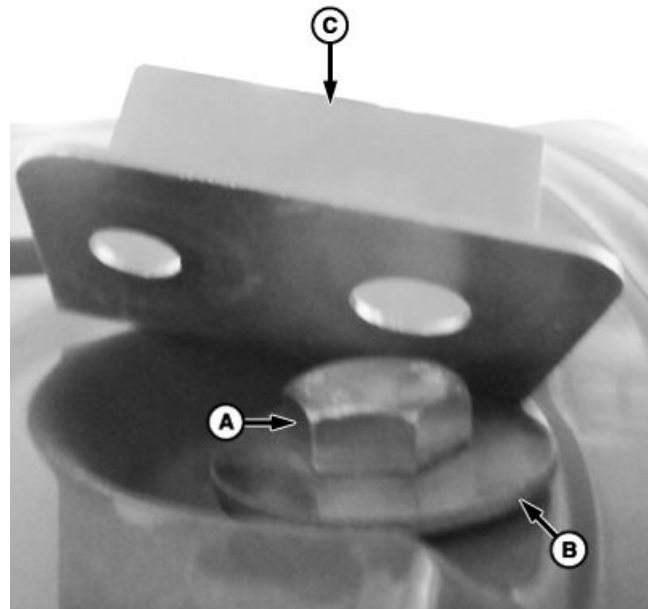

Antenna Bracket Installation

Continued on next page

bvmsit,1680071433915 -19-02MAY23-5/13

PC16328—UN—12DEC12

6. Install antenna (A) to the upper side of coax adapter (B) on the antenna bracket (C) as shown.
7. Connect antenna cable (D) to the lower side of coax adapter (B) as shown.

A—Antenna  
B—Coax Adapter

C—Antenna Bracket  
D—Antenna Cable

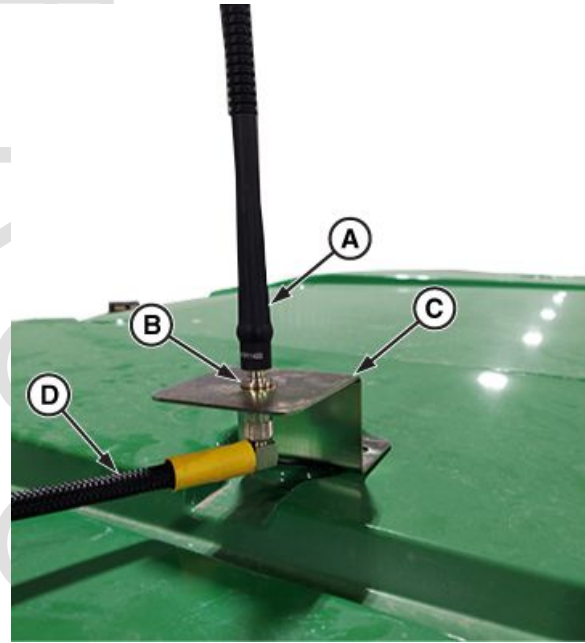

*Antenna Installation*

Continued on next page

bvmsit,1680071433915 -19-02MAY23-6/13

APY80371 —UN—29MAR23

P  
R  
O  
O  
F

*NOTE: Thoroughly clean the surface before mounting the adhesive anchor on the machine.*

8. Route antenna cable (A) towards the right rear pillar (C) of the cab. Then into the dust cover. Secure harness with P-clamps (B) and adhesive anchors.

*NOTE: Ensure that the antenna cable (A) is not tangled with any component on the machine.*

A—Antenna Cable                      C—Right Rear Pillar  
 B—P-Clamp (2 used)

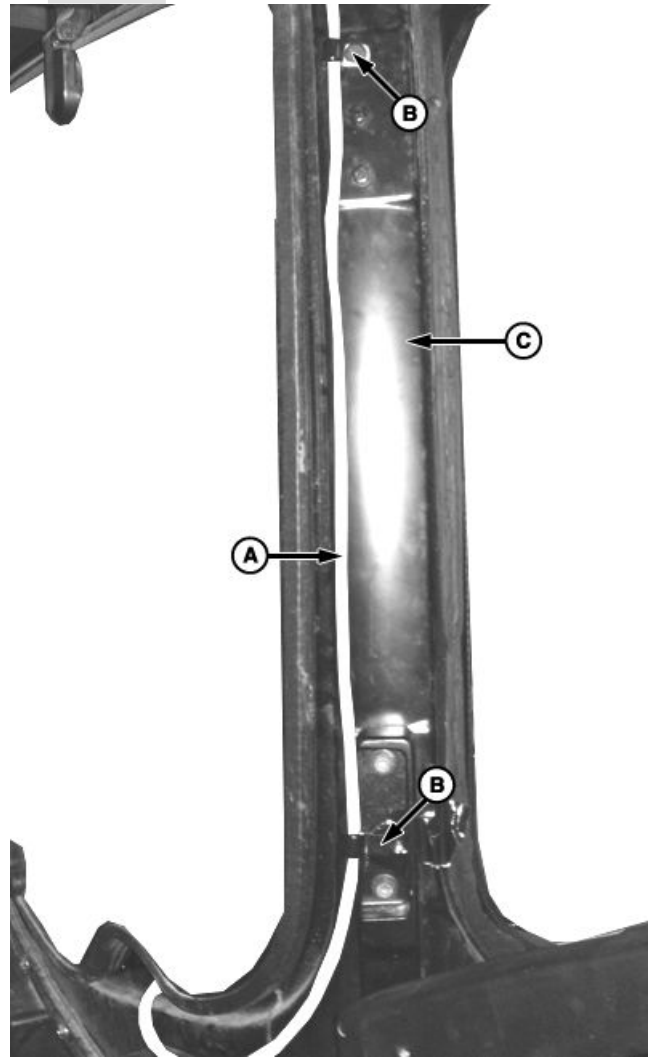

Antenna Cable Routing

Continued on next page

bvmsit,1680071433915 -19-02MAY23-7/13

PC14498 —UN—25JAN12

PROOF

9. Remove outlet cover cap screw (A), cab pillar cover cap screws (B) and left rear pillar cover (C).
10. The JDLINK Modem is located behind the radio. Either remove the radio or the business band radio compartment to access the JDLINK Modem antenna connector.

A—Cap Screw

B—Cap Screw (2 used)

C—Right Rear Pillar Cover



*Left Rear Pillar Cover Removal*

Continued on next page

bvmsit,1680071433915 -19-02MAY23-8/13

APY80372 —UN—29MAR23

**11. Radio Option:**

- a. Remove radio bezel (A) and cap screws (B).
- b. Disconnect wire harness connector (C) and remove display unit.

**A—Radio Bezel**  
**B—Cap Screw (2 used)**

**C—Wire Harness Connector**

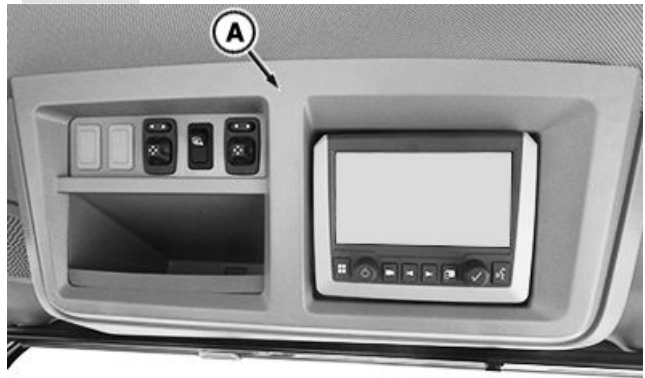

*Radio Bezel Removal*



*Cap Screw Removal*

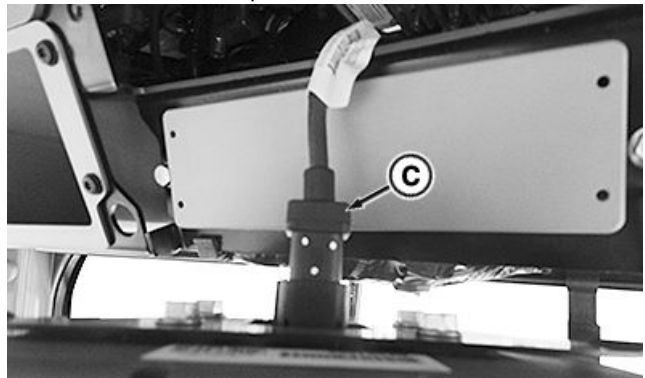

*Wiring Harness Disconnection*

RXA0169604 —UN—11JUL19

RXA0169605 —UN—11JUL19

RXA0169606 —UN—11JUL19

Continued on next page

bvmsit,1680071433915 -19-02MAY23-9/13

**12. Business Band Radio Compartment Option:**

- a. Remove radio bezel (A) and cap screws (B).
- b. Remove CB radio compartment.

**A—Radio Bezel**

**B—Cap Screw (2 used)**

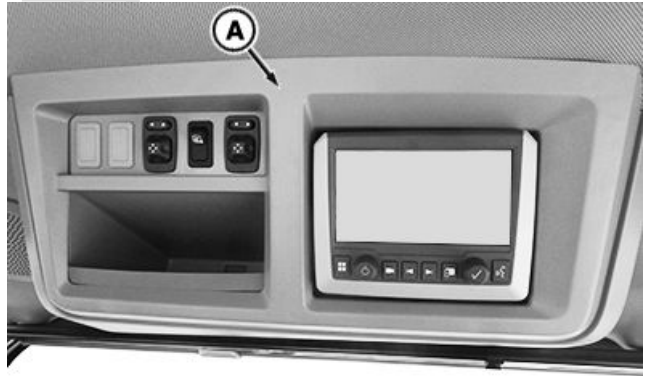

*Radio Bezel Removal*



*CB Radio Compartment*

RXA0169604 —UN—11-JUL19

APY80373 —UN—29-MAR23

Continued on next page

bvmsit,1680071433915 -19-02MAY23-10/13



13. Disconnect existing wireless antenna connector (A) from the JDLink Modem (B).

**A—Wireless Antenna Connector**

**B—JDLink Modem**

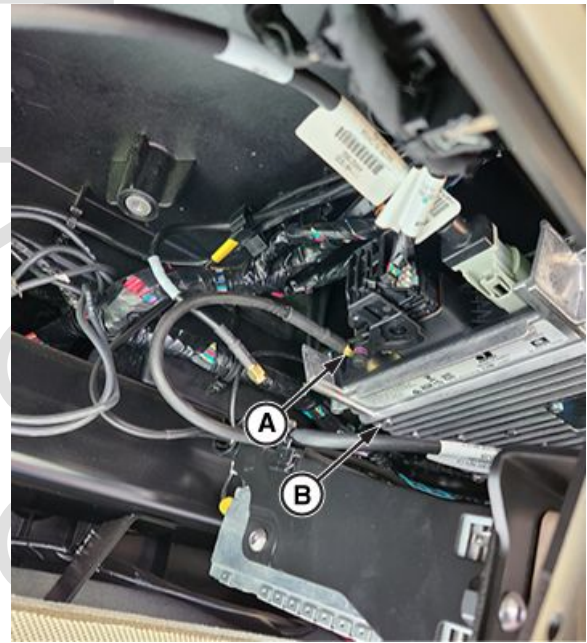

*Wireless Antenna Cable Location*

bvmsit,1680071433915 -19-02MAY23-11/13

APY80374—UN—29MAR23

14. Route antenna cable (A) up left rear corner post towards the JDLink Modem.

**A—Antenna Cable**



*Antenna Cable Routing*

Continued on next page

bvmsit,1680071433915 -19-02MAY23-12/13

APY80375—UN—29MAR23

15. Connect antenna cable (A) to JDLink Modem (B) wireless antenna connector.
16. Secure excess antenna cable with tie band at suitable location.
17. Install all hardware in the reverse order of removal.

**A—Antenna Cable**

**B—JDLink Modem**

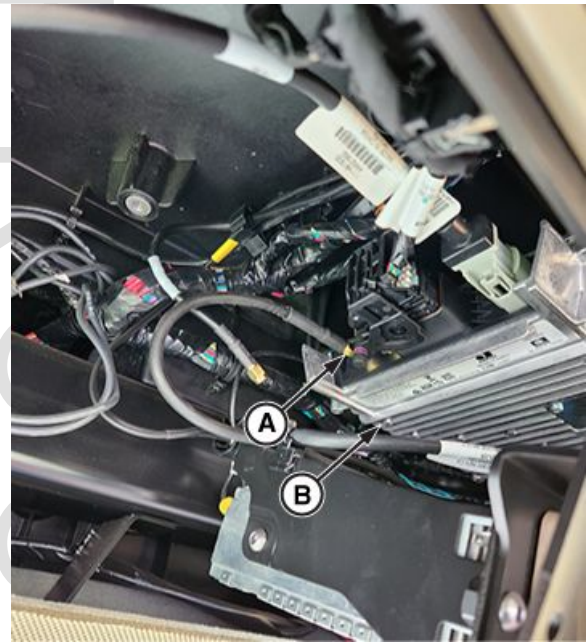

*Antenna Cable Connection*

bvmsit,1680071433915 -19-02MAY23-13/13

APY80374—UN—29MAR23

PROOF

PROOF PROOF

PROOF PROOF