

# JDLINK™ Machine Messenger



**JOHN DEERE**

## INSTALLATION INSTRUCTIONS JDLINK Machine Messenger PC20103 09JAN02 (ENGLISH)

**8020, 9020**

**John Deere Ag Management Solutions  
PC20103 (09JAN02)**

COPYRIGHT © 2001  
DEERE & COMPANY  
Moline, Illinois  
All rights reserved  
A John Deere ILLUSTRATION® Manual

PC20103-19-09JAN02



### Recognize Safety Information

This is a safety-alert symbol. When you see this symbol on your machine or in this manual, be alert to the potential for personal injury.

Follow recommended precautions and safe operating practices.



TB1389 -UN-07DEC88

DX.ALERT -19-29SEP98-1/1

### JDLINK Wiring Harness Reference

- A—Socket Connector To Controller
- B—CAN Bus Terminator Connector
- C—Ground wire
- D—CCD Bus Connector
- E—CAN Bus Terminator Connector
- F—Unswitched And Switch Power Wires
- G—SCV Panel Connector
- H—10 Amp Fuses

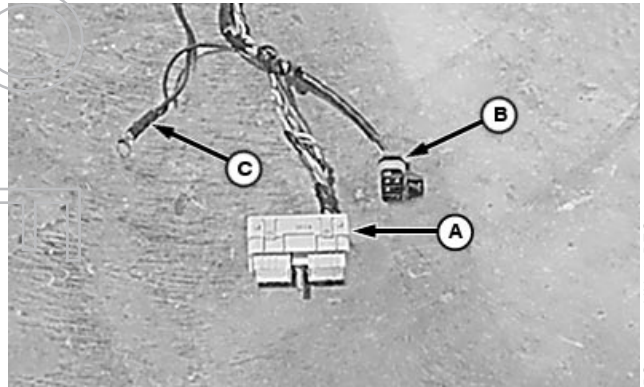

PC6783 -UN-19DEC01

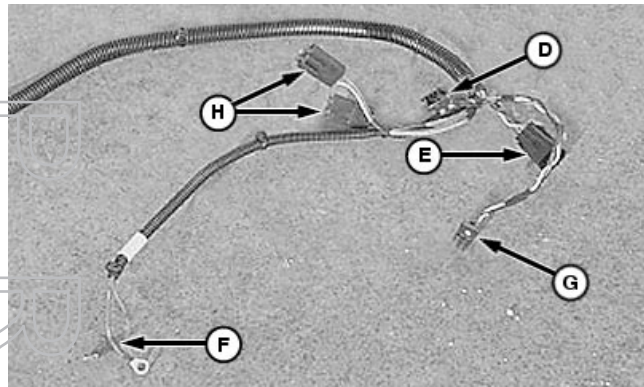

PC6782 -UN-19DEC01

OOU6091,0001435 -19-20AUG01-1/1

## Install JDLINK™ Machine Messenger

**IMPORTANT:** Avoid damage to electrical system of tractor when installing JDLINK wiring harness. Disconnect battery ground.

*NOTE:* After installing JDLINK Machine Messenger and before reassembling cab roof, login to JDLINK website at [www.jdlink.com](http://www.jdlink.com), go to Dealer Menu/Setup New Device wizard and follow online procedures. These procedures will allow JDLINK communication controller's serial number to be verified and tractor's serial number to be entered for proper system operation.

*Reference of JDLINK Machine Messenger's Technical Manual is required for this instruction.*

1. Shut off engine, set parking brake and remove key.

**NOTE:** If tractor is equipped with JDLINK wiring harness go to step 11.

2. Remove TORX® screws (A).
3. Remove plastic rivets (B).
4. Remove cap screw (C).

**NOTE:** To access console screws (D), remove fuse panel cover.

5. Remove screws (D) and console cover (E).

- A—TORX Screws
- B—Plastic Rivets
- C—Cap Screw
- D—Screws
- E—Console Cover

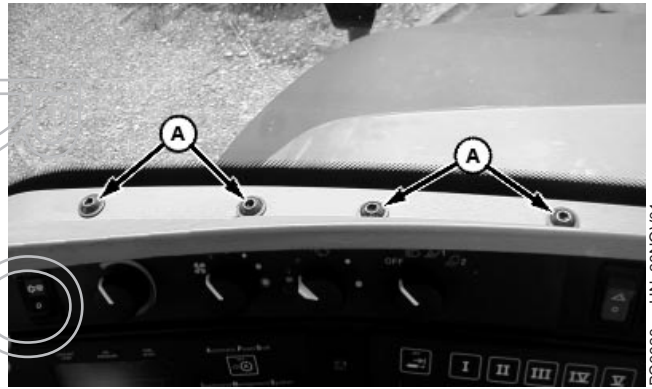

PC6928 -UN-28NOV01

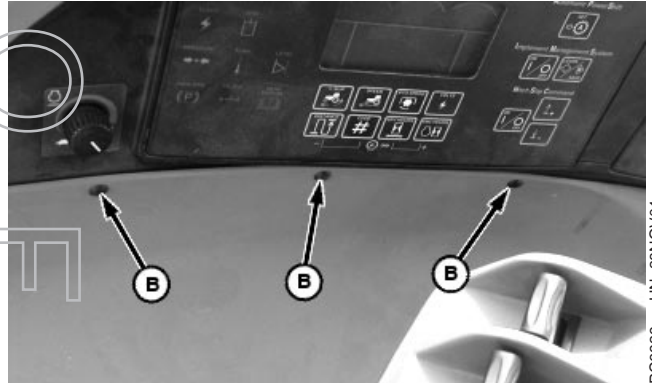

PC6929 -UN-28NOV01

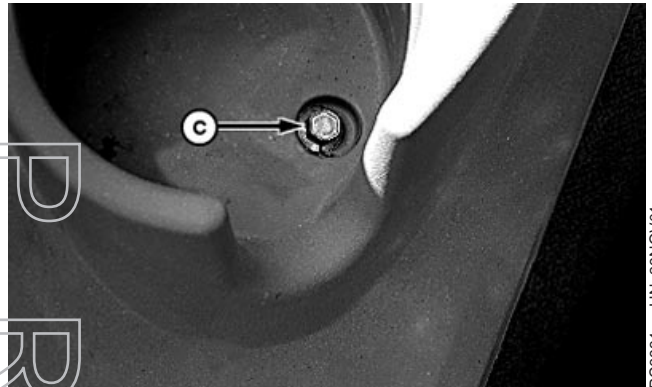

PC6931 -UN-29NOV01

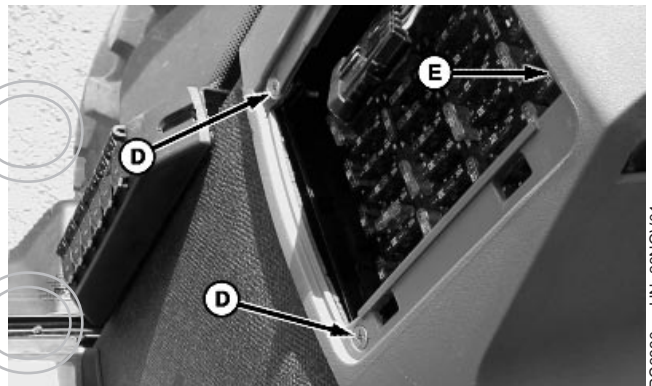

PC6930 -UN-28NOV01

6. Remove right rear shroud screws (A) and shroud (B).

- A—Shroud Screws
- B—Post Shroud

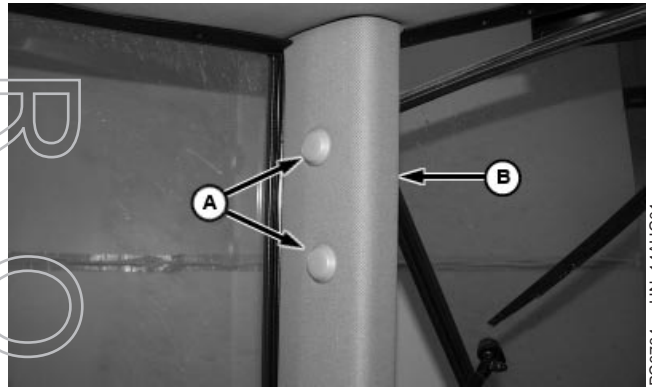

OUO6091.0001433 -19-14AUG01-3/27

*NOTE: Remove headliner enough to route wiring harness down right-rear corner post.*

7. Remove screw (A), light (B), trim screws (C) and headliner trim (D).

- A—Screw
- B—Light
- C—Trim Screws
- D—Trim

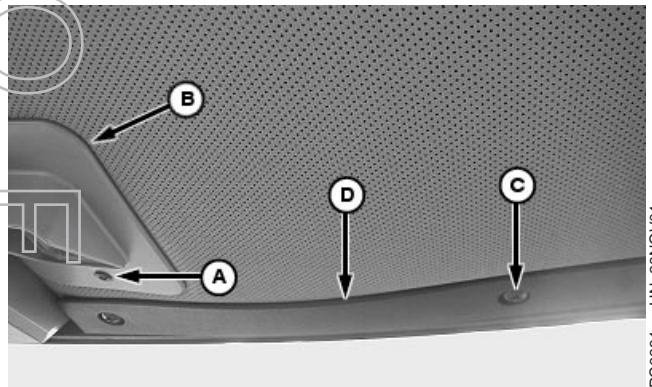

OUO6091.0001433 -19-14AUG01-4/27

8. Remove right rear window molding (A).

- A—Rear Window Molding

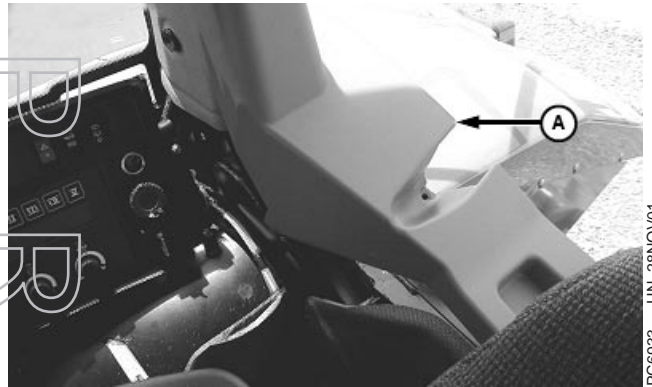

OUO6091.0001433 -19-14AUG01-5/27

9. Remove screw (A), panel spacer (B) and SCV setup panel (C).

- A—Screw
- B—Panel Spacer
- C—SCV Panel

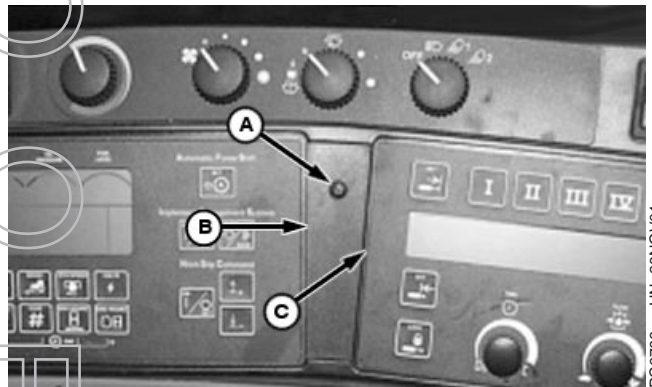

Continued on next page

OUO6091.0001433 -19-14AUG01-6/27

**NOTE:** CAN bus terminator will be reinstalled on roof of cab in a following step.

10. Disconnect and remove CAN bus terminator (A).

**A—CAN Bus Terminator**

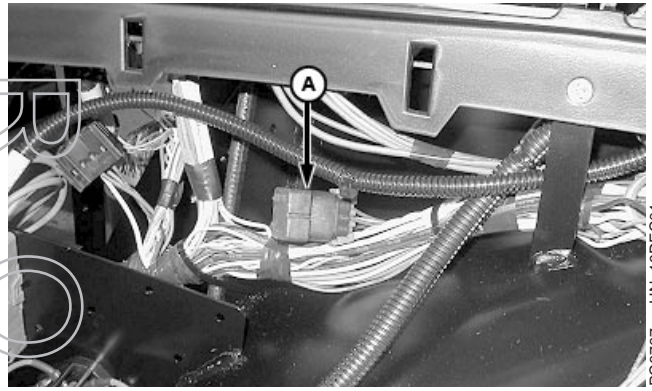

OUO6091,0001433 -19-14AUG01-7/27

11. Remove flange cap screws (A) and mirror (B).
12. Disconnect and remove STARFIRE™ receiver, if equipped.

**NOTE:** Refer to machine Technical Manual for removal of rear cab lights and radio antenna.

13. Remove rear cab lights and disconnect radio antenna.

**A—Cap Screws**  
**B—Mirror**



OUO6091,0001433 -19-14AUG01-8/27

STARFIRE is a trademark of Deere & Company

**NOTE:** Cab roof is awkward to handle, use suitable lifting device or two technicians.

14. Remove cap screws (A and B), washers and cab roof (C).

**A—Cap Screws (16 used)**  
**B—Cap Screws (2 used)**  
**C—Cab Roof**

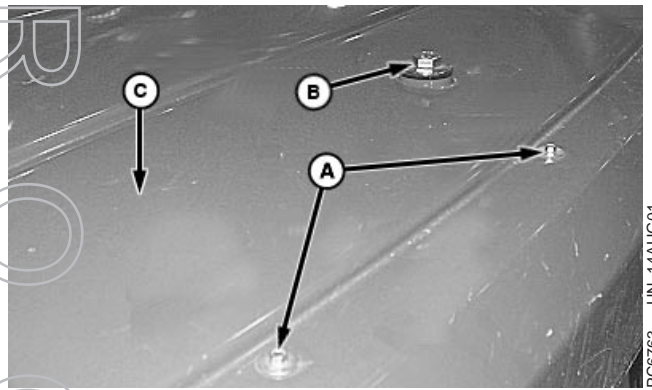

Continued on next page

OUO6091,0001433 -19-14AUG01-9/27

15. Connect coax cables (A and B) to antenna assembly (C).

**IMPORTANT:** Improperly installed antenna and receiver may interfere with the operation of machine's electronic system and possibly subject operator to higher than recommended radio frequency emission levels.

16. Attach antenna assembly to right rear-window hinge using existing cap screws (D).

- A—Coax
- B—Coax
- C—Antenna Assembly
- D—Cap Screws

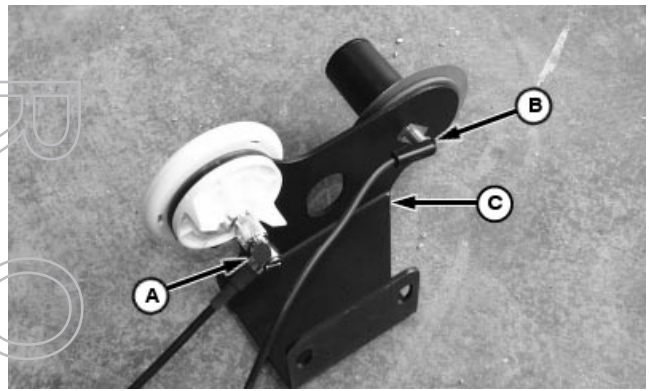

PC6781 -UN-20AUG01

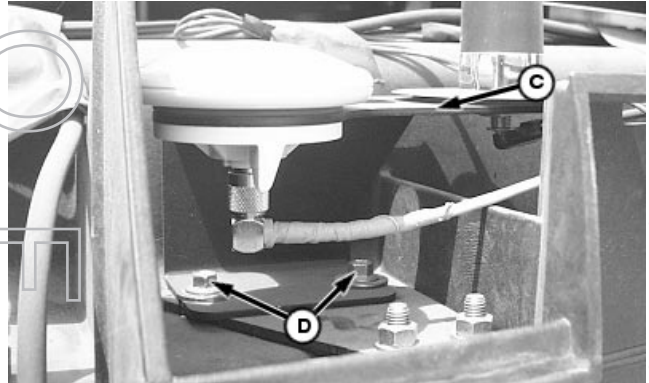

PC6771 -UN-20AUG01

OUO6091,0001433 -19-14AUG01-10/27

**NOTE:** For all machines, route coax cables on right side of cab.

17. Route coax cables (A) on right side of tractor cab from antenna assembly (B) to controller (C).

- A—Coax Cable
- B—Antenna Assembly
- C—Controller

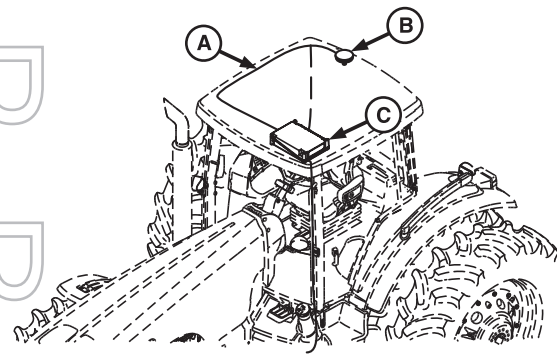

Reference Of 8020

PC6938 -UN-29NOV01

Continued on next page

OUO6091,0001433 -19-14AUG01-11/27



**NOTE:** Use pullout templates (included with this instruction) to locate and drill holes at left front section of cab. Templates below are for reference only. If tractor is equipped with JDLINK wiring harness, skip to step 21.

18. Install templates (A) and tape corners of templates to brackets. Locate and mark four holes (B) for drilling.
19. Remove templates.
20. Drill four 8 mm (5/16 in) holes (B).

A—Template  
B—Hole Guides

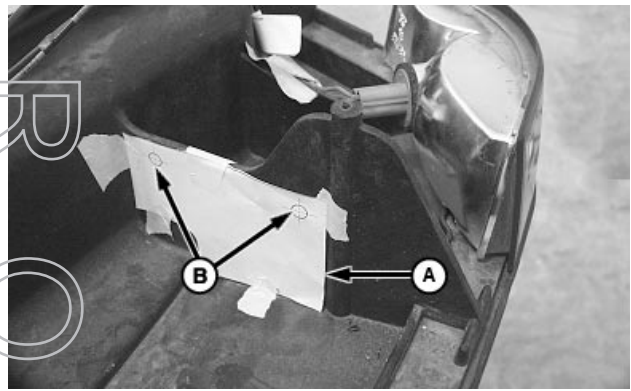

PC6768 -UN-14AUG01

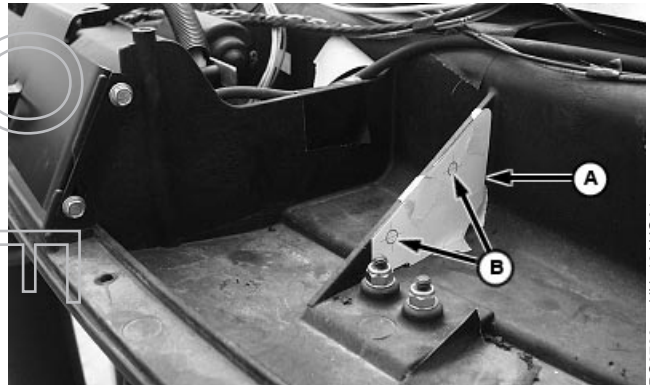

PC6769 -UN-16AUG01

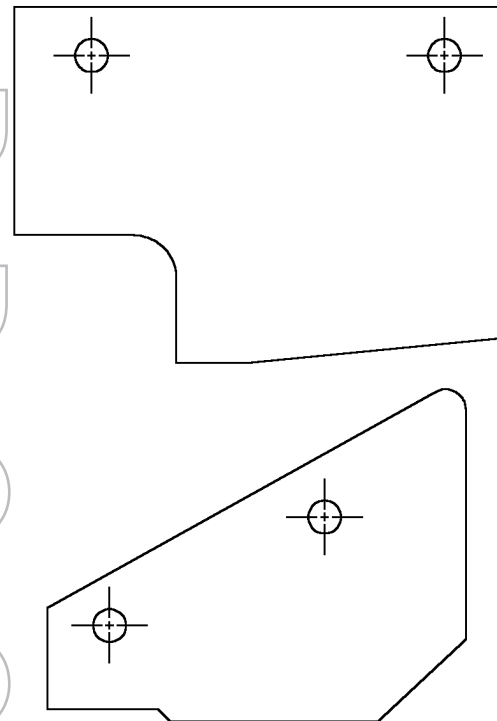

Template (Reference Only)

PC6760 -UN-10AUG01

Continued on next page

OUC6091,0001433 -19-14AUG01-12/27

21. Attach coax cables (A) to controller (B).
  22. Connect JDLINK wiring harness connector (C) to controller and tighten cap screw (D).
- NOTE: Record controller's 13 digit serial number for a following step.*
23. Install terminator (E) and retain with tie straps.

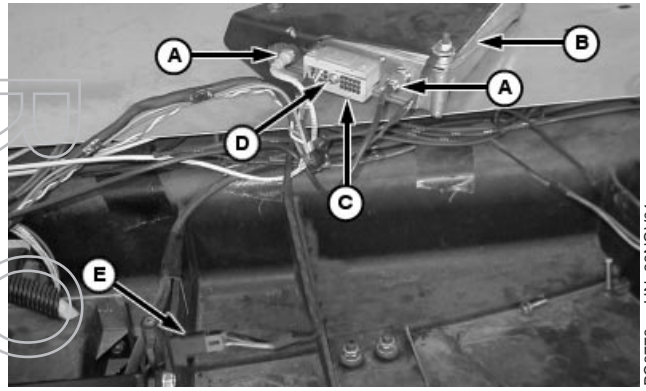

PC6773 -UN-28NOV01

OOU6091,0001433 -19-14AUG01-13/27

24. Attach controller (A), using four 6 mm cap screws (B).
25. Attach ground wire from JDLINK wiring harness (C) to controller using existing nut (D).

- A—Controller
- B—Cap Screws (4 used)
- C—Ground Wire
- D—Nut

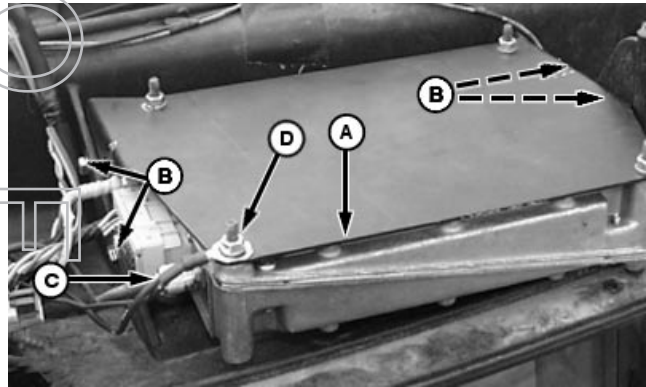

PC6780 -UN-28NOV01

Continued on next page

OOU6091,0001433 -19-14AUG01-14/27

U  
R  
O  
O  
T

**NOTE:** Record machine's 13 digit serial number for a following step.

If equipped with JDLINK wiring harness skip to step 32.

Place controller ground wire next to chassis behind second nut.

- 26. Route ground wire (C) along side of windshield washer hose and connect to chassis ground (E).

- A—JDLINK Controller
- B—JDLINK Antenna Assembly
- C—Ground Wire
- D—JDLINK Wiring Harness
- E—Chassis Post

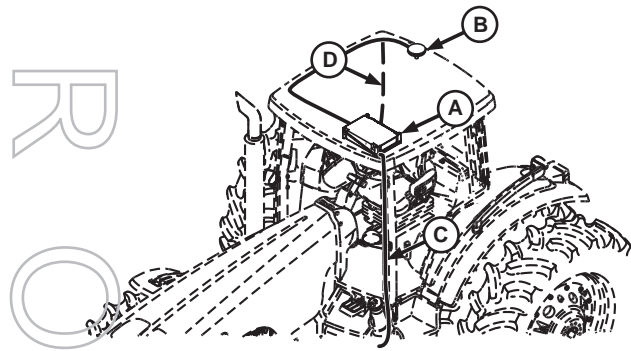

Ground Wire Route For 8020 Wheel And 9020 Track

PC6761 -UN-15AUG01

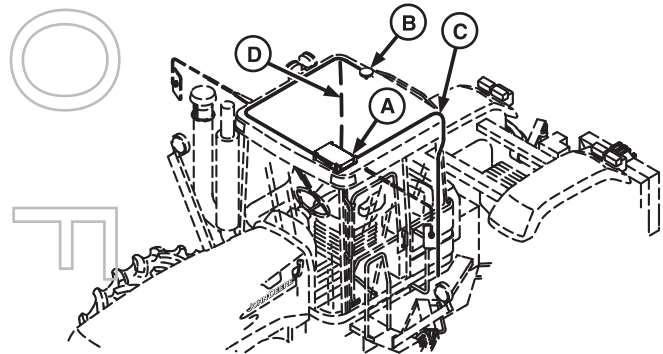

Ground Wire Route for 9020 Wheel

PC6966 -UN-18DEC01

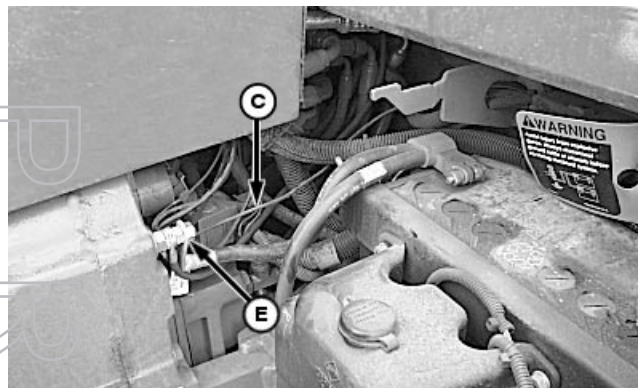

Chassis Ground for 8020

PC6774 -UN-14AUG01

Continued on next page

OOU6091,0001433 -19-14AUG01-15/27

**IMPORTANT:** Avoid damage to antenna coax cables and JDLINK wiring harness when reinstalling cab roof. Tie strap wiring harness and coax cables in areas on top of cab to prevent damage of wires and cables (tie strap cables and wiring harness together from right rear cab slot to controller).

27. Route JDLINK wiring harness (A) to SCV panel through slot (B) at right rear cab post.

A—JDLINK Wiring Harness  
B—Cab Slot

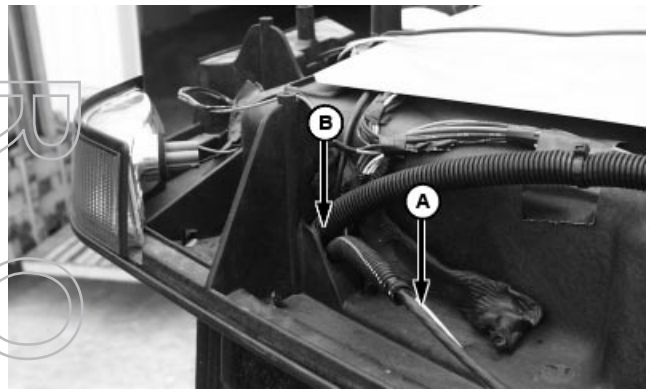

PC6775 -UN-14AUG01

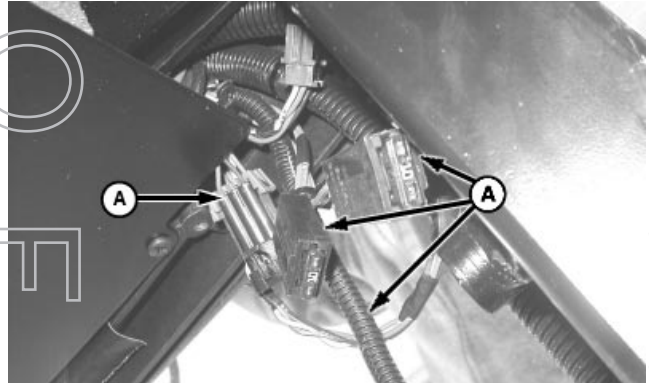

PC6939 -UN-28NOV01

OUO6091,0001433 -19-14AUG01-16/27

28. Connect JDLINK connector to CAN bus terminator connector (A).

A—JDLINK Connector And CAN Bus Terminator Connector



PC6971 -UN-20DEC01

OUO6091,0001433 -19-14AUG01-17/27

29. Connect JDLINK unswitch power wire (A) to post (B) and power switch wire (C) to post (D) with hardware provided.

A—Unswitch Power Wire, 262  
B—Post  
C—Switch Power Wire, 192  
D—Power Post

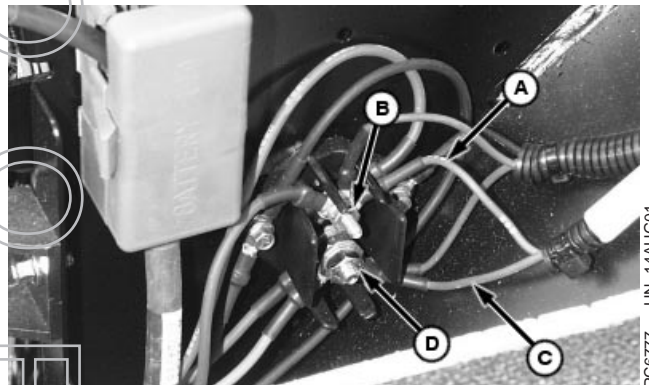

PC6777 -UN-14AUG01

Continued on next page

OUO6091,0001433 -19-14AUG01-18/27

*NOTE: Reference JDLINK wiring harness at beginning of instruction for CCD Bus connector.*

30. Connect JDLINK SCV connector (B) to SCV panel wiring harness connector (A).

**A—JDLINK SCV Connector**  
**B—SCV Panel Wiring Harness Connector**

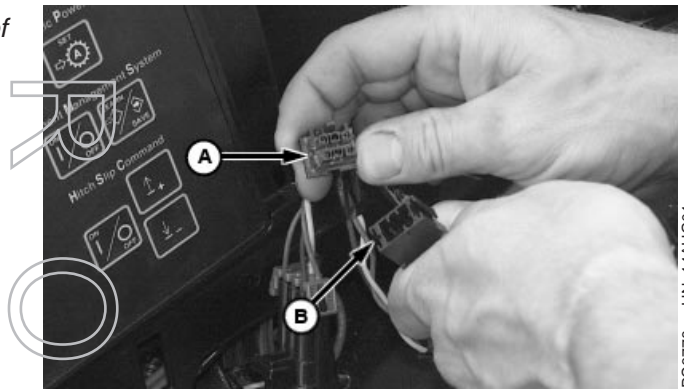

PC6778 -UN-14AUG01

Continued on next page

OOU6091,0001433 -19-14AUG01-19/27

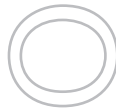

31. Connect JDLINK wiring harness CCD Bus connector (A) to SCV panel (B).

32. Reconnect battery ground.

**IMPORTANT: Avoid damage to machine, reinstall machine enough to be moved but do not fully reassemble until proper operation of JDLINK is confirmed.**

33. To properly confirm operation of JDLINK, move machine to an open area so it has clear view of sky horizon.

34. Shut off engine , set parking brake.

35. Reference JDLINK Machine Messenger's Technical Manual to force a contact from the machine to confirm cell service.

*NOTE: Machine must be turned to the RUN position for five minutes before step 6 of 8 in the online Setup Confirmation procedure of the machine and controller.*

36. Login to JDLINK website, go to Dealer Menu/Setup New Device Wizard and follow online procedures, which will include the input of machine and controller's serial number.

37. Confirm test data (i.e. time/date, map location, machine's engine hours and electronics system information).

If data is correct reassemble machine, if data is incorrect call 1-888-GRNSTAR.

38. Shut off engine, set parking brake and remove key.

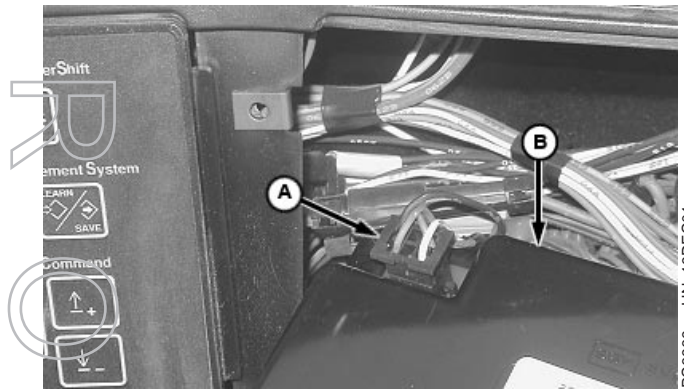

PC6969 -JUN-19DEC01

A—CCD Bus Connector  
B—SCV Panel

Continued on next page

OUO6091,0001433 -19-14AUG01-20/27

*NOTE: If equipped with JDLINK wiring harness skip to step 47.*

39. Reinstall SCV panel (C), panel spacer (B) and retain with screw (A).

- A—Screw
- B—SCV Panel Spacer
- C—SCV Panel

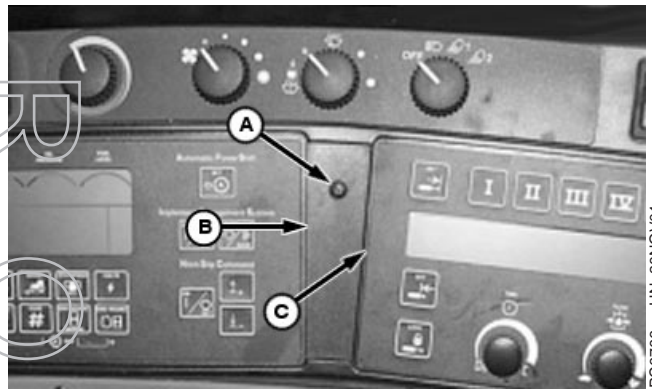

PC6766 -UN-28NOV01

Continued on next page

OUC6091,0001433 -19-14AUG01-21/27



*NOTE: After reinstallation of console, reinstall fuse panel cover.*

- 40. Reinstall console (E) and screws (D).
- 41. Reinstall cap screw (C) and new rivets (B).
- 42. Reinstall TORX screws (A).

- A—TORX Screws
- B—Rivets
- C—Cap Screw
- D—Screws
- E—Console

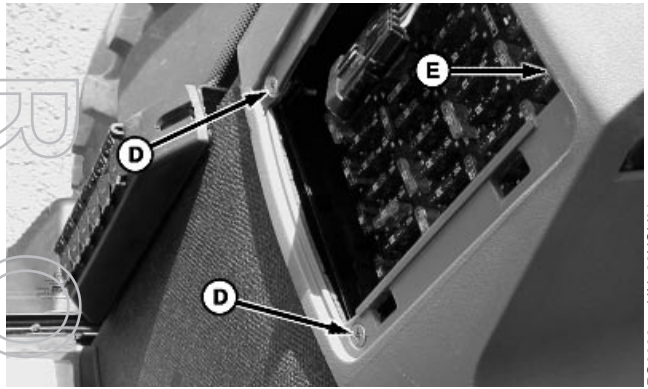

PC6830 -JUN-28NOV01

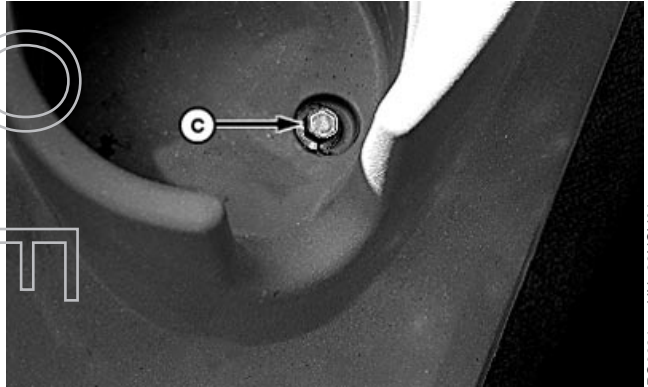

PC6831 -JUN-29NOV01

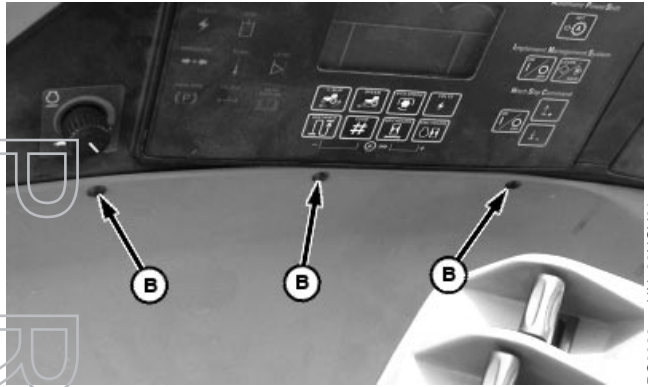

PC6929 -JUN-28NOV01

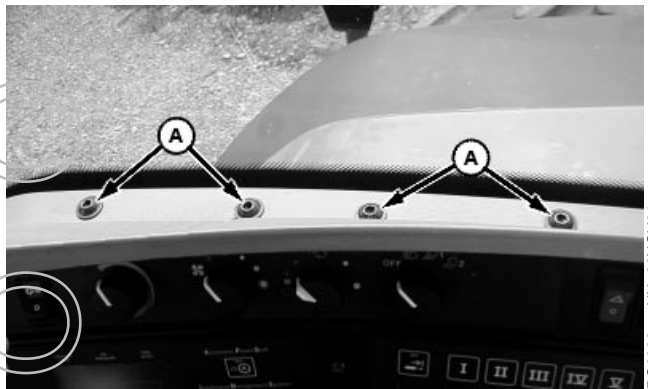

PC6928 -JUN-28NOV01

Continued on next page

OOU6091,0001433 -19-14AUG01-22/27



43. Reinstall rear window molding (A).

A—Rear Window Molding



PC6933 -UN-28NOV01

OUO6091,0001433 -19-14AUG01-23/27

44. Reinstall headliner trim (D) retain with screws (C).

45. Reinstall light (B) and retain with screw (A).

A—Screw  
B—Light  
C—Trim  
D—Trim Screws

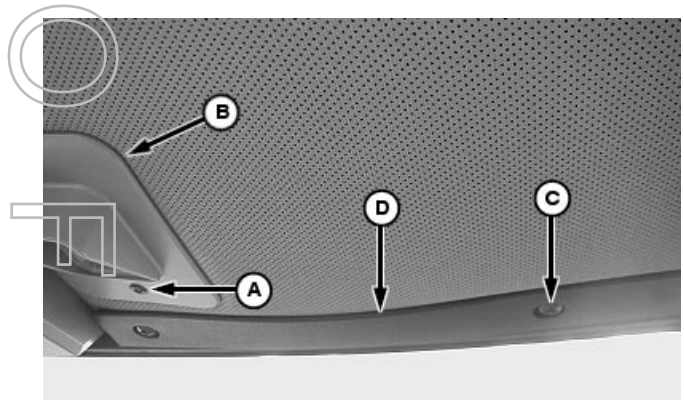

PC6934 -UN-28NOV01

OUO6091,0001433 -19-14AUG01-24/27

46. Reinstall right rear corner post shroud (B) retain with shroud screws (A).

A—Shroud Screws (2 used)  
B—Corner Post Shroud

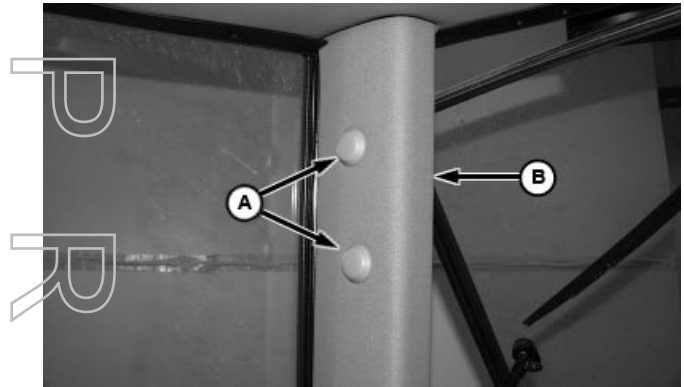

PC6764 -UN-14AUG01

OUO6091,0001433 -19-14AUG01-25/27

**NOTE:** Reinstall radio antenna coax and rear lights before installing cap screws.

47. Reinstall roof (C) and retain with washers and cap screws (A and B).

A—Cap Screws and Washers (16 used)  
B—Cap Screws and Washers (2 used)

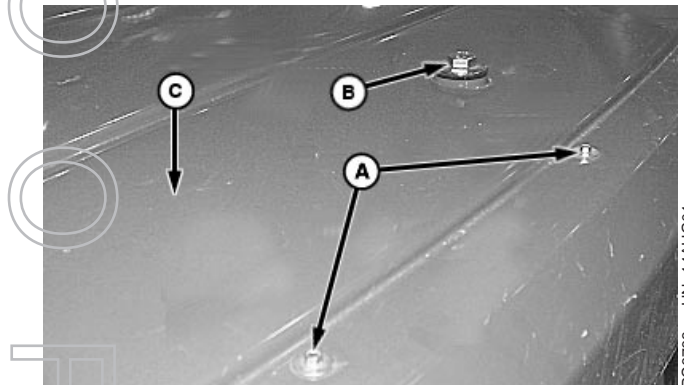

PC6763 -UN-14AUG01

Continued on next page

OUO6091,0001433 -19-14AUG01-26/27

- 48. Reinstall mirror (B) and retain with cap screws (A).
- 49. Reinstall STARFIRE receiver, if equipped.

A—Cap Screws  
B—Mirror

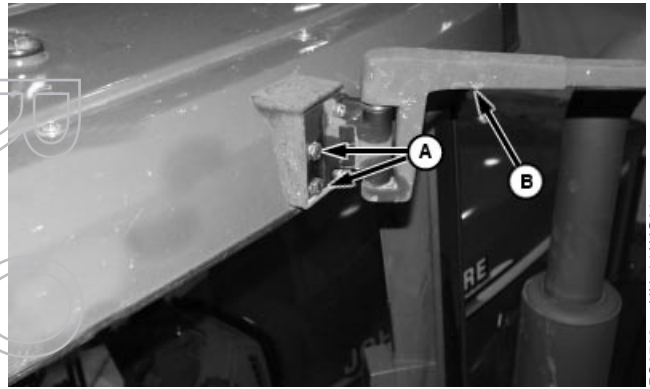

OUC6091,0001433 -19-14AUG01-27/27

O

F

R

R

O

O

F