

proxSafe[®]

mini

**Wiring & Installation
Instructions**

V06/05/08

© Copyright 2008 by deister electronic GmbH

All rights reserved. No part of this publication may be reproduced, stored in a retrieval system, or transmitted, in any form or by any means, electronic, mechanical, photocopying, recording, or otherwise, without prior written permission of deister electronic GmbH.

deister electronic GmbH reserves the right to make changes to any and all parts of this documentation without obligation to notify any person or entity of such changes.

May 2008 JR/IO/BF

deister electronic GmbH
Hermann-Bahlsen Str. 11
30890 Barsinghausen
Germany
Phone: +49 (0) 51 05 - 51 61 11
Fax: +49 (0) 51 05 - 51 62 17
E-Mail: info@deister-gmbh.de
Web: www.deister.com

Contents

1.	Technical data	4
1.1	Electrical characteristics.....	4
1.2	Housing	4
1.3	Customer interfaces	5
1.3.1	Communication	5
1.3.2	Power.....	6
1.4	Relay.....	6
1.5	Battery.....	7
2.	Wiring diagram	7
2.1	Signalisation	7
2.2	Configuration	7
2.3	Air interface	7
3.	General	8
4.	Implementing hints	9
5.	Shutter is blocked.....	9
6.	Emergency unlock	10
7.	Regulatory notices.....	13
7.1	Europe	13
7.2	FCC Digital Device Limitations.....	13

1. Technical data

1.1 Electrical characteristics

UB: 12-13,8V/DC*

In: 50mA (Standby)

I_{max}: 2,3A (during closing or opening, if no other components activated)

1.2 Housing

Width: 440mm without mounting angle
484mm with mounting angle

Height: 133mm

Depth: 173mm

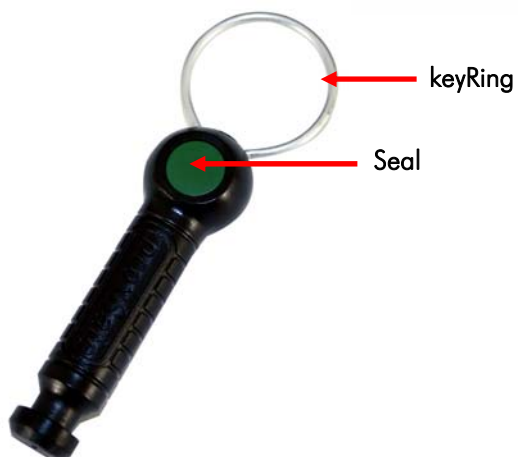

keyTag



proxCylinder

* 13,8 V needed if a battery is connected and needs to be charged
12 V if no battery charging is required.

This refers to all voltages in the manual.

1.3 Customer interfaces

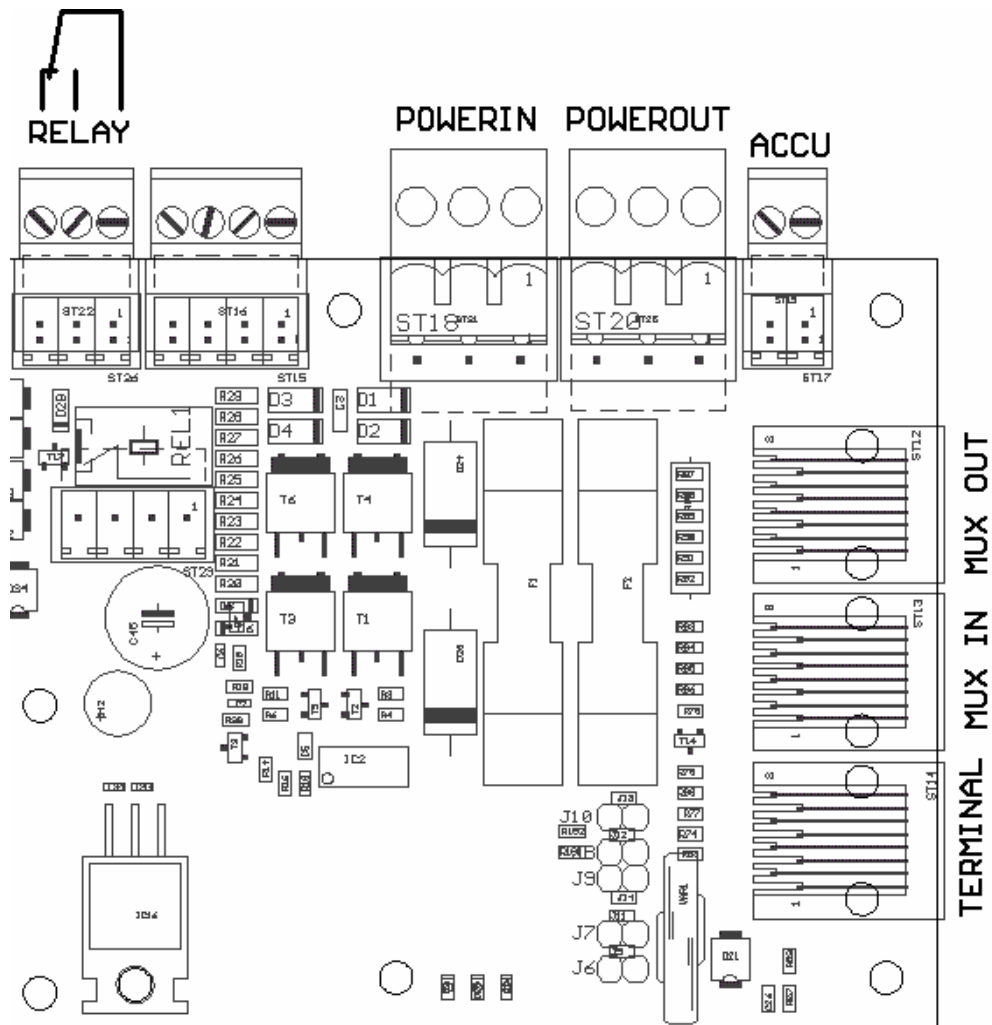

Figure 1: interfaces

1.3.1 Communication

RS485 deBus, 9600 Baud, 1 startbit, no parity, 1 stopbit, 8 bits

RJ45 Connector

Connect TERMINAL of the multiplexer to HOST (e.g. via SNG3)

Pin	Description
1	nc
2	nc
3	GND
4	GND
5	+UB (13ss,8V)
6	+UB (13,8V)
7	RS485 B
8	RS485 A

MUX IN: Data line from previous multiplexer

Pin	Description
1	nc
2	nc
3	GND
4	GND
5	+UB (13,8V)
6	+UB (13,8V)
7	RS485 B
8	RS485 A

MUX OUT: Data line to next multiplexer

Pin	Description
1	nc
2	nc
3	GND
4	GND
5	+UB (13,8V)
6	+UB (13,8V)
7	RS485 B
8	RS485 A

1.3.2 Power

3-Pin Connector, green RM5

POWER IN: Power line from previous multiplexer or from power supply

Pin	Description
1	nc
2	13,8V
3	GND

3-Pin Connector, green RM5

POWER OUT: Power line to next multiplexer

Pin	Description
1	nc
2	13,8V
3	GND

1.4 Relay

3-Position Field Wiring Connector, green RM3.5
(see Figure 1)

1.5 Battery

2-Pin Field Wiring Connector, Battery

Pin	Description
1	ACCU +
2	GND

2. Wiring diagram

The deBus supports a maximum of 32 devices. The amount of necessary power supplies is depending on the application (e.g. if shutters are used or not). In this example an SNG3 adapter is used to connect the data line to the HOST.

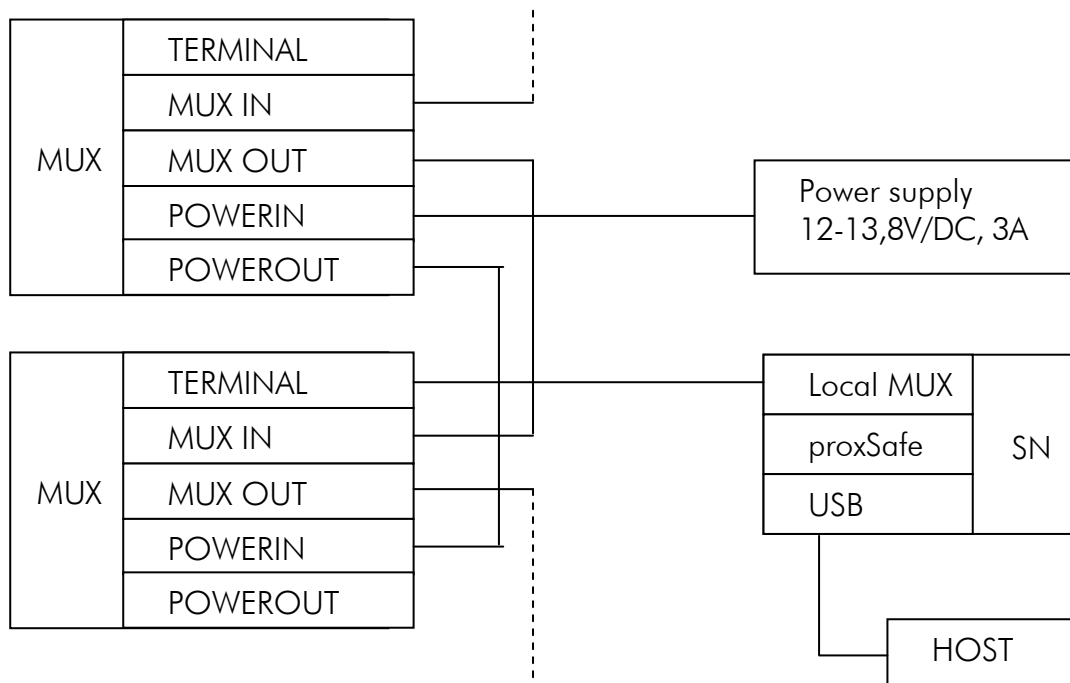

2.1 Signalisation

Beeper internal
Red LED internal
Green LED internal
Yellow LED internal

2.2 Configuration

Only device address is configurable (see deBus description).

Possible device addresses: 0x22,0x23,0x25...0x2F,0x41...0x4F,0x51,0x52

0x21 is standard address on delivery.

2.3 Air interface

Frequency: 125KHz

Bitrate: 4Kbit

3. General

proxSafe mini is part of a keyTag management system.
With proxSafe mini you can handle up to 8 proxCylinders in one device.
Connection of the proxCylinders is done by RJ45 connectors.
Each proxCylinder contains of the following devices:

- Relay for keyTag release
- Coil for keyTag identification
- Red LED for optical signalisation
- End switch for detecting, if the proxCylinder is occupied

UB: 13,8V/DC

proxSafe has a serial interface for communication:
RS485, 9600 Baud, no parity, 1 stopbit, 8 bits

Protocol: deBus

The following parts of the proxSafe can be controlled by the host:

- Beeper
- Yellow LED
- Red LED main board
- Red LEDs proxCylinders
- Relay proxCylinders
- Lock
- Motor

Following states are controlled by the main board:

- Tamper
- Low voltage
- Device alert (shutter blocked)
- Status lock
- Status cabinet (open, closed, in move or undefined)
- Status end switch top
- Status end switch bottom
- Voltage on antenna of the proxCylinders
(only after reset or after command "Get Image")

4. Implementing hints

You will find the implementing hints in the debus protocol for the proxsafe mini (available on request).

5. Shutter is blocked

If the terminal gives a signal to the multiplexer to close the shutter and the shutter is blocked, the multiplexer tries closing the shutter for three times. If the third attempt failed, the shutter remains in this position. The device alert flag is set (see error codes in debus protocol description). The beeper of the multiplexer is activated regularly for a short time. The beeper can be deactivated by sending a "Set Output"-command with TIM = 0x00 and StdIo = virtual beeper. The device alert flag is not influenced by this command. The device alert flag is reset by sending the "Reset Status"-command or if the next closing of the shutter succeeds.

6. Emergency unlock

If normal operation failed (e.g. processor does not work) to get keys out, an emergency unlock is integrated. The components for emergency unlock are at the backside of the proxSafe mini.

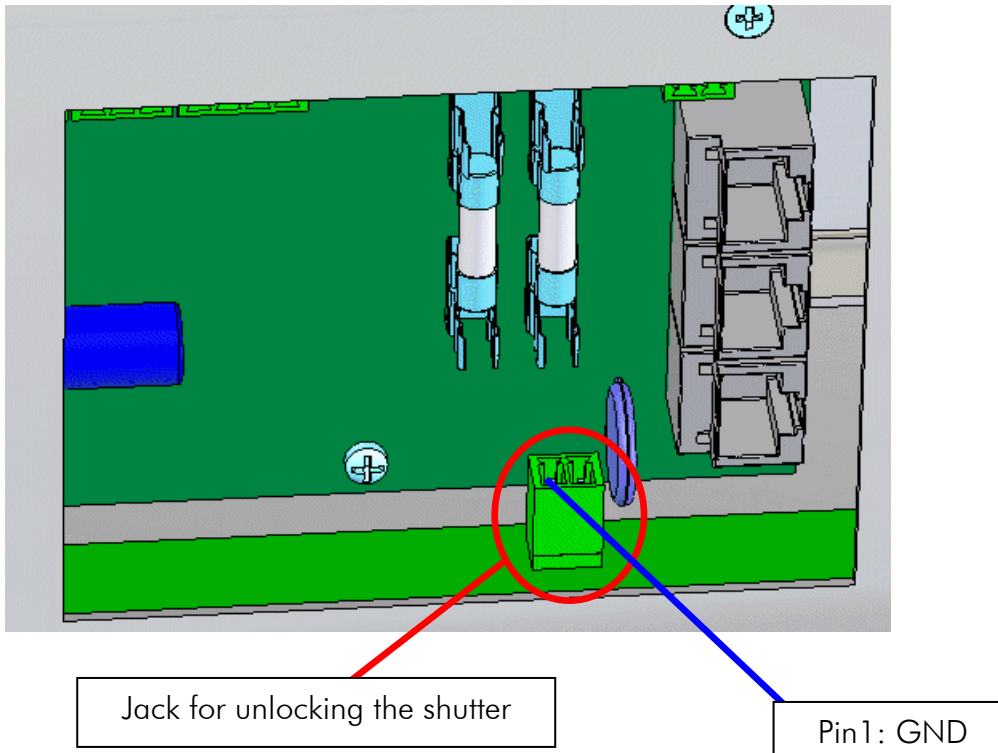

The first step is to open the shutter. The shutter is protected against opening by hand. For this reason in case of emergency the jack (red marked in the picture above) must be connected to the emergency opening box with the 2-pole cable (enclosed) as follows in order to unlock the shutter:

Pin	Connection
1	GND
2	12-13,8V/DC

While the jack is connected **and the switch of the emergency opening box is being pressed constantly**, the shutter can be opened by hand using a tool (for example a screw driver).

.mini

After the shutter has been opened this way, in a second step the emergency unlock for the proxCylinders must now be activated separately as follows:

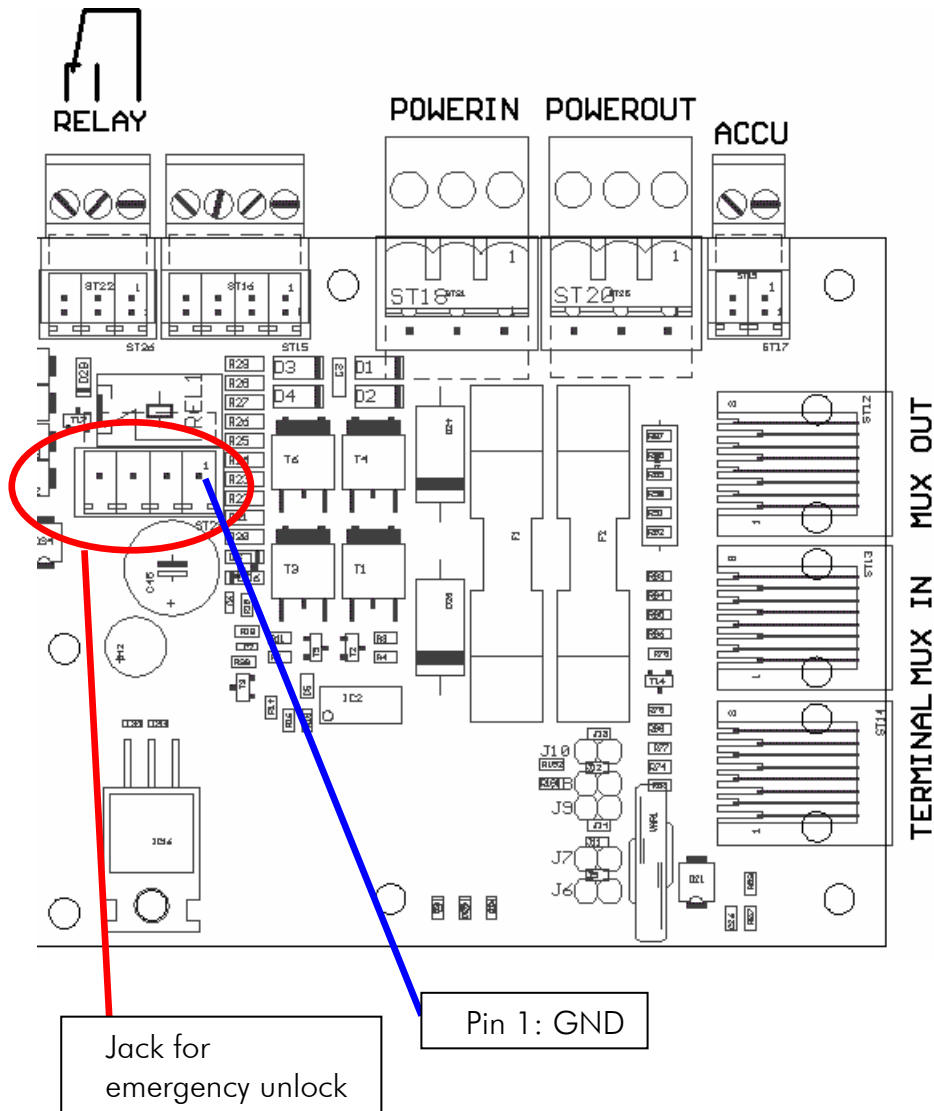

To activate this emergency unlock, the jack (red marked in the picture above) must be connected to the emergency opening box with the 4-pole cable (enclosed) as follows:

Pin	Connection
1	GND
2	12 -13,8V/DC
3	12 -13,8V/DC
4	12 -13,8V/DC

While this jack is connected **and the switch of the emergency box is being pressed constantly**, all keys can be taken out.

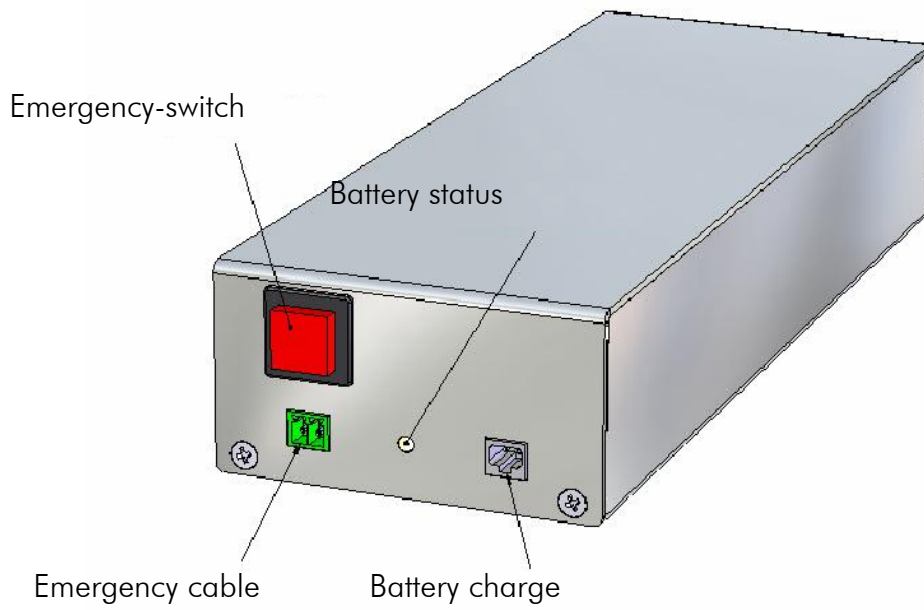

Emergency opening box with two different cables (one 2-pole-cable and one 4-pole cable)

7. Regulatory notices

7.1 Europe

Hereby, deister electronic GmbH declares that this equipment - if used according to the instructions - is in compliance with the essential requirements and other relevant provisions of the RTTE Directive 1999/5/ EC.

A complete declaration of conformity can be requested at:

info@deister-gmbh.de



Approved for use in all European countries.

7.2 FCC Digital Device Limitations

Radio and Television Interference

This equipment has been tested and found to comply with the limits for a Class A digital device, pursuant to Part 15 of the FCC rules. These limits are designed to provide reasonable protection against harmful interference when the equipment is operated in a commercial environment. This equipment generates uses and can radiate radio frequency energy and, if not installed and used in accordance with the instruction manual, may cause harmful interference to radio communications. Operation of this equipment in a residential area is likely to cause harmful interference, in which case the user will be required to correct the interference at his own expense.

This device complies with Part 15 of the FCC rules. Operation is subject to the following two conditions: (1) This device may not cause harmful interference, and (2) this device must accept any interference received, including interference that may cause undesired operation.

In order to maintain compliance with FCC regulations, shielded cables must be used with this equipment. Operation with non-approved equipment or unshielded cables is likely to result in interference to radio and television reception.

Caution! Changes or modifications not expressly approved by the manufacturer could void the user's authority to operate this equipment.

7.3 FCC Notice

To comply with FCC part 15 rules in the United States, the system must be professionally installed to ensure compliance with the Part 15 certification. It is the responsibility of the operator and professional installer to ensure that only certified systems are deployed in the United States. The use of the system in any other combination (such as co-located antennas transmitting the same information) is expressly forbidden.

7.4 Industry Canada

This Class A digital apparatus complies with Canadian ICES-003.
Cet appareil numérique de la classe A est conforme à la norme NMB-003 du Canada.

Germany:

deister electronic GmbH
Hermann-Bahlsen Str. 11
30890 Barsinghausen
Tel.: +49 (0) 51 05 - 51 61 11
Fax: +49 (0) 51 05 - 51 62 17
info@deister-gmbh.de

www.deister.com

Belgien & Luxemburg:

deister electronic office
Business Park E 19
Battelsesteenweg 455/A
2800 Mechelen
Tel.: +32 (0) 15 - 28 09 68
Fax: +32 (0) 15 - 28 09 71
info@benelux.deister.com

Frankreich:

deister electronic france
101 rue Pierre Semard
92320 Chatillon
Tel.: +33 (0) 1 47 - 35 78 78
Fax: +33 (0) 1 47 - 35 92 59
info@deister.fr

Großbritannien:

deister electronic (UK) Ltd.
Stapleton Way, Enterprise Park
Spalding, Lincolnshire
PE11 3YQ
Tel.: +44 (0) 1775 - 717100
Fax: +44 (0) 1775 - 717101
info@deister.co.uk

Niederlande:

deister electronic office
Tolnasingel 3
2411 PV Bodegraven
Tel.: +31 (0) 1726 - 32970
Fax: +31 (0) 1726 - 32971
info@nl.deister.com

Kanada:

Deister Electronics Inc.
1099 Kingston Road, Suite 212
Pickering, ON L1V 1B5
Tel.: +1 905 - 837 5666
Fax: +1 905 - 837 0777
info@deister-electronic.com

Japan:

deister electronic Japan, LTD.
Toshiba Hoshikawa Bldg. 4F
2-4 Kawabe-chô
Hodogaya-ku, Yokohama-shi
Kanagawa, 240-0001
Tel.: +81 (0) 45 340 1831
Fax: +81 (0) 45 340 1801
info@deister.jp

USA:

Deister Electronic USA, Inc.
9303 Grant Avenue
Manassas, VA 20110
Tel.: +1 703 - 368 2739
Fax: +1 703 - 368 9791
info@deister.com