



Dekolink WIRELESS Ltd.
16 Bazel St. Qiryat-Arieh Petah-Tikva, Israel, 49510
Tel- 972-3-9180-180 Fax-972-3- -
e-mail: marketing@decolink.com web www.decolink.com

INSTALLATION AND OPERATING INSTRUCTIONS FOR HIGH POWER REPEATER MODEL: MW-BDA-ESMR-50W90





Dekolink WIRELESS Ltd.
16 Bazel St. Qiryat-Arieh Petah-Tikva, Israel, 49510
Tel- 972-3-9180-180 Fax-972-3- -
e-mail: marketing@decolink.com web www.decolink.com

TABLE OF CONTENTS

| PARAGRAPH | PAGE No |
|--|----------------|
| REPEATER OVERVIEW | 3 |
| BLOCK DIAGRAM DESCRIPTION | 3 |
| REPEATER (BDA) CONNECTION | 3 |
| STEP ATTENUATOR & RF GAIN & SETTING | 4 |
| AGC FUNCTION | 4 |
| BDA MONITOR | 5 |
| BDA MONITOR FUNCTIONS | 6 |
| BDA INSTALLATION | 8 |
| BASE / DONOR ANTENNA INSTALLATION | 8 |
| REMOTE / MOBILE SERVICE ANTENNA INSTALLATION | 8 |
| ANTENNA ISOLATION | 8 |
| INSTALLATION STEPS | 9 |
| RF EXPOSURE WARNING | 10 |
| ELECTRICAL SPECIFICATIONS | 11 |
| MECHANICAL SPECIFICATIONS | 11 |
| ENVIRONMENTAL CONDITIONS | 11 |
| MECHANICAL LAYOUT | 12 |
| MECHANICAL OUTLINE | 13 |
| LIMITED WARRANTY | 14 |

LIST OF DRAWINGS

| DRAWING | PAGE No |
|--------------------------------|----------------|
| REPEATER(BDA) RF BLOCK DIAGRAM | 4 |
| BDA MONITOR | 7 |
| BDA MONITOR BLOCK DIAGRAM | 7 |
| MECHANICAL LAYOUT | 13 |
| MECHANICAL OUTLINE | 13 |



Dekolink WIRELESS Ltd.
16 Bazel St. Qiryat-Arieh Petah-Tikva, Israel, 49510
Tel- 972-3-9180-180 Fax-972-3- -
e-mail: marketing@decolink.com web www.decolink.com

REPEATER OVERVIEW:

The Bi-Directional Repeater assembly provides an exceptional repeater/booster performance to extend the coverage area of radio communications in buildings and RF shielded environments.

Features such as high linearity power amplifiers are contributing for the overall improved system linearity performances. The unit is based on a duplexed path configuration, having sharp out of band attenuation for improved isolation between the receiving and transmitting paths.

BLOCK DIAGRAM DESCRIPTION:

The Repeater Downlink path receives the RF signals from base station, amplifies them and transmits them to the subscriber. The Repeater Uplink path receives the RF signals from the subscriber, amplifies them and transmits them to the base station. Two duplexers frequency separate the signals to the proper amplifying path and isolate the two signals.

For each path two amplifiers do the path signal amplification; a low noise amplifier (LNA) and a high power amplifier. The low noise amplifier has a 30 dB step attenuator to set the gain of the specific path.

REPEATER (BDA) CONNECTION

The RF connection is made via two type "N" female connectors. The RF connector labeled "Base" must be connected to the antenna pointing to the base station; usually a rooftop antenna. The RF connection labeled "Mobile" must be connected to the antenna pointing into the area to be covered by the Repeater such as inside a building or outdoor shaded area.



Dekolink WIRELESS Ltd.
16 Bazel St. Qiryat-Arieh Petah-Tikva, Israel, 49510
Tel- 972-3-9180-180 Fax-972-3- -
e-mail: marketing@decolink.com web www.decolink.com

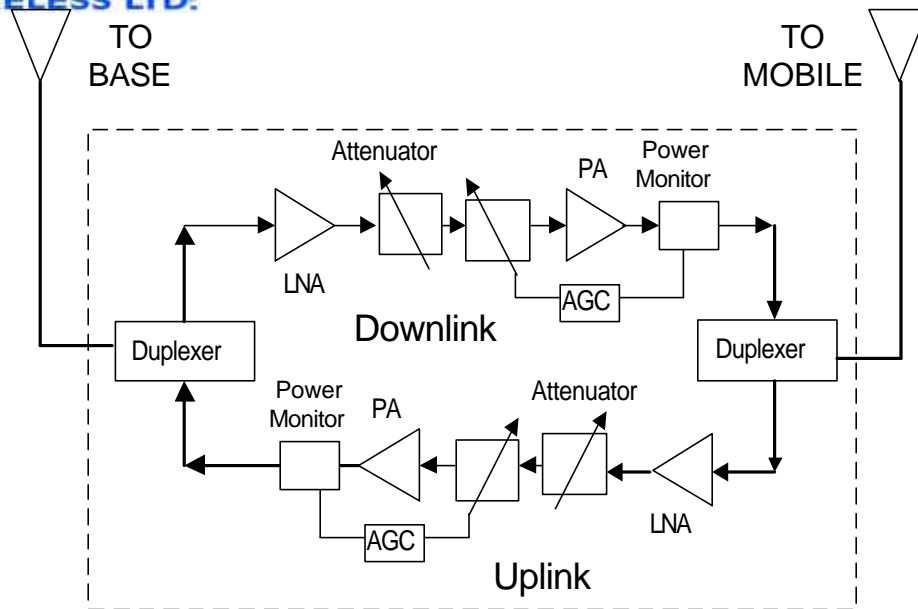

BDA RF BLOCK DIAGRAM

STEP ATTENUATOR AND RF GAIN SETTING

For proper operation of the Repeater, the isolation between the base station antenna and the mobile antenna should exceed the Repeater gain by at least 12 dB. If the Repeater gain were higher than the isolation between the antennas, oscillation would start and would saturate the amplifier. Isolation few dB higher than the Repeater gain cannot start oscillations but would cause gain ripple in the band.

The step attenuator on the low noise amplifier reduces the Repeater gain. The Repeater gain can be stepped down by the amount indicated on the step attenuator.

AGC FUNCTION

The Repeater has AGC function on both paths that serve to prevent the saturation of the power amplifier. When a high signal is received the AGC circuit detects the amplitude and sends a feedback signal to a variable attenuator, which attenuates the signal level so that the output power of the amplifier does not exceed the preset limit. The green LED on the BDA monitor (AGC Range) illuminates when the power output of the amplifier is within the set limit. An On/Off switch on the connection box enables the AGC function. If the AGC is disabled then the amplifier gives maximum gain.

WARNING: For proper operation the AGC switch must be ON to prevent excessive spurious.



Dekolink WIRELESS Ltd.
16 Bazel St. Qiryat-Arieh Petah-Tikva, Israel, 49510
Tel- 972-3-9180-180 Fax-972-3- -
e-mail: marketing@decolink.com web www.decolink.com

BDA MONITOR

The BDA monitor circuit monitors the following functions:

RF power transmitted by the power amplifiers.

For the **downlink channel** a red fault LED illuminates if the power is 10 dB below the specified composite power. In normal use the downlink channel continuously transmits RF signals and this LED should be on. When the donor reception from the base is bad this LED turns on to warn that the repeater is not being used efficiently. Another green LED illuminates when the power reaches or exceeds this power (10W). This is used to set the repeater gain. This limit is the same as the AGC limit and is factory preset.

For the **uplink channel** a green indicator LED illuminates when the power reaches or exceeds its composite power (1W). When the isolation between the antennas is bad this LED lites permanently. This LED should turns on only when a near by cellular is used. This limit is the same as the AGC limit and is factory preset.

DC voltage of the channels. The fault LED illuminates when the voltage is below or above the specified limits.

DC current to each of the two LNAs and the uplink power amplifier. If the current is below or above the specified limits then a LED illuminates.



Dekolink WIRELESS Ltd.
16 Bazel St. Qiryat-Arieh Petah-Tikva, Israel, 49510
Tel- 972-3-9180-180 Fax-972-3- -
e-mail: marketing@decolink.com web www.decolink.com

BDA MONITOR FUNCTIONS

P.S. (Uplink & down link) Illuminates when the Power Supply voltage is below or above its limits.

P.AMP. (Uplink) Illuminates when the uplink Power Amplifier current is above or below its specified limits

P.AMP. (Downlink) Illuminates when the uplink RF Power is 10 dB below the specified composite power.

L.N.A. (Uplink & Downlink) Illuminates when the Low Noise Amplifier current is above or below its specified limits.

AGC Range. (Downlink) This green LED on the downlink path illuminates when the transmitted power reaches or exceeds the AGC set power, which is the maximum specified composite power. For best efficient use of repeater RF power this LED should be on.

AGC Range. (Uplink) This green LED on the downlink path illuminates when the transmitted power reaches or exceeds the AGC set power, which is the maximum specified composite power. This LED should not lit permanently. It lights only when a nearby mobile is transmitting.

The **Pushbutton Switch** on the BDA monitor turns on all the alarms. This is used to test the alarm functions of the BDA.

REMOTE ALARM The BDA monitor has a dry contact relay arms output. These contacts are short circuit at no fault and open circuit at any fault or at power loss. This function can be used to operate a modem for remote alarm warning. The relay contacts are connected to pins A and C (small pins) on the alarm connector at the front panel.



Dekolink WIRELESS Ltd.
 16 Bazel St. Qiryat-Arieh Petah-Tikva, Israel, 49510
 Tel- 972-3-9180-180 Fax-972-3-
 e-mail: marketing@decolink.com web www.decolink.com

**BDA
MONITOR**

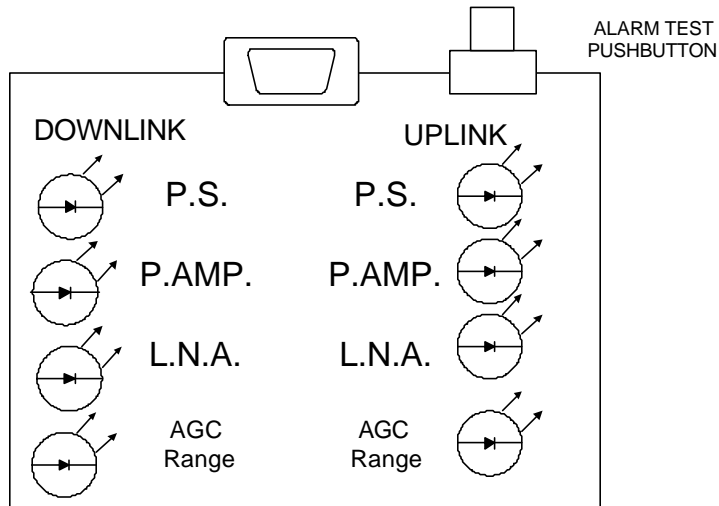

**BLOCK
DIGRAM**

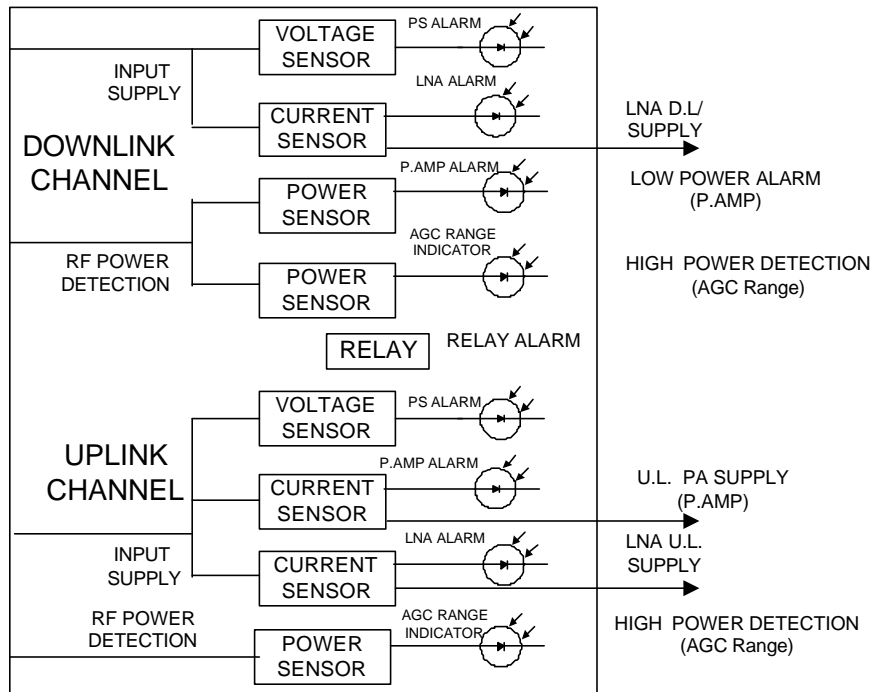



Dekolink WIRELESS Ltd.
16 Bazel St. Qiryat-Arieh Petah-Tikva, Israel, 49510
Tel- 972-3-9180-180 Fax-972-3- -
e-mail: marketing@decolink.com web www.decolink.com

BDA INSTALLTION

Install the BDA Repeater in a shielded, ventilated and easy to reach area. Use low loss cables to connect antennas to the BDA. Install the BDA close to the service area to improve output power and noise figure.

The BDA Base/Donor connector port is connected to donor antenna, usually a Yagi antenna, while the BDA Mobile/Remote connector port is connected to a mobile antenna; outdoor indoor.

BASE / DONOR ANTENNA INSTALLTION

Typically this is a directional antenna such as Yagi or Dish antenna of 10 to 15 dB gain. This antenna is pointed to the base station to get maximum input power. This antenna should be in line of sight with the base site. Raise this antenna higher if no line of site is achieved. The required Base signals should be the dominant signals; at least 6 dB higher power than other signals.

Choose the antenna site to get the maximum isolation from the remote (mobile serving) antenna.

REMOTE / MOBILE ANTENNA INSTALLTION

The remote antenna is an Omni antenna or a directional antenna according to the coverage requirements.

For indoor applications covering a large building, the RF signals are split using power dividers and distributed to many antennas each covering a floor or a small area.

ANTENNA ISOLATION

For proper operation the isolation between these two antennas must be at least 12 dB higher than the BDA gain. Lower isolation would lead to high in-band ripple. Oscillations will build up when the isolation is lower than BDA gain.

The isolation between the antennas is critical for high gain outdoor repeaters.

To measure the isolation; inject a known signal into one antenna and measure the power at the other antenna. This should be done across the frequency range of both uplink and downlink bands.



INSTALLATION STEPS

1. Install all antennas and connect them to the BDA inputs.
2. Turn the AGC On for both Uplink and Downlink power amplifiers. This AGC limits the output power of the BDA to the desired level.

WARNING: For proper operation the AGC switch must be ON to prevent excessive spurious beyond FCC limitation.

The AGC on the Downlink path guarantees constant downlink power when and if the Donor power changes.

3. Set downlink gain to minimum; uplink gain to minimum.
4. Increase the downlink channel gain till the green LED turns from off to on. This is the best gain setting giving highest usable power.
5. The green LED on the downlink power amplifier will illuminate if adequate donor power has reached the BDA. If the donor power is low the LED will not lit and the BDA usable power is not used efficiently. The red LED will illuminate if the donor power is 10 dB or more below the maximum usable power indicating a fault.
6. Set the uplink gain to the same as the downlink gain.
7. Check that the uplink green LED on the BDA monitor does not lit permanently. This LED would lit permanently If the isolation between antennas is low (BDA oscillations) or the BDA is faulty. In such a case:
 - Disconnect one of the cables from the BDA connectors and connect a load at the connectors.
 - If the LED on this amplifier illuminates permanently then the BDA is faulty (oscillating) and needs replacing.
 - If the LEDs stops illuminating then the isolation between the donor and remote antennas is low. Either improve the isolation (e.g. increase separation) or reduce BDA gain.
 - To reduce gain, reconnect the antenna cables. Reduce the gain at both uplink and downlink path until this LED stops illuminating. Reduce the gain further by 10 dB. This is the maximum usable gain.



Dekolink WIRELESS Ltd.
16 Bazel St. Qiryat-Arieh Petah-Tikva, Israel, 49510
Tel- 972-3-9180-180 Fax-972-3- -
e-mail: marketing@decolink.com web www.decolink.com

RF EXPOSURE WARNING

In order to satisfy the FCC RF exposure requirements, you must ensure that the installation complies with the following:

One antenna is connected via cable that has typical 1~10 dB attenuation (depends on the length of the cable) to the BDA base port. This antenna is installed outdoor and has very sharp beam (Yagi type or similar) pointed to the donor (BTS). This type of antenna has about 10 dBi gain. Typical specifications: gain: 8 dBd (=10.1 dBi), VSWR: better than 1.5:1 , Impedance: 50 ohm. The outdoor antenna must be installed to provide a minimum separation distance of 1 m (100 cm) from persons within the area.

The second antenna is connected via cable that has typical 1~10 dB attenuation (depends on the length of the cable) to the BDA MOBILE port. This type of antenna is omnidirectional (isotropic), or wide beam, with 0 to 2 dBi typical gain and is installed and distributes indoor (in buildings, tunnels, basements, park lots, shopping centers etc.). Typical specifications: gain: 2 dBi, VSWR: better than 2:1 , Impedance: 50 ohm. For direct connection to the BDA this antenna must be installed to provide a minimum separation distance of 2 m (200 cm) from persons within the area.

Less separation is needed if the power from this power is divided into many antennas covering many floors or areas.



Dekolink WIRELESS Ltd.
 16 Bazel St. Qiryat-Arieh Petah-Tikva, Israel, 49510
 Tel- 972-3-9180-180 Fax-972-3- -
 e-mail: marketing@decolink.com web www.decolink.com

ELECTRICAL SPECIFICATIONS:

| PARAMETER | SPECIFICATIONS | |
|---------------------------------------|--|-------------|
| | Down Link | Up Link |
| Frequency Range | 851-866 MHz | 806-821MHz |
| Gain | 90±4 dB | |
| Pass Band ripple | <3 dB p-p | |
| Manual Attenuation Range | 0 to 30dB in 2dB Step | |
| Noise Figure | 5dB | |
| Output Power @ 1 dB compression | 50W | 16W |
| 3 rd order intercept point | 62 dBm typ. | 50 dBm typ. |
| Composite Power Output, max | +40dBm | +31dBm |
| Down Link IMD @ two tone 37dBm each | 50 dBc | ----- |
| Up Link IMD @ two tone 27dBm each | ----- | 44 dBc |
| AGC Factory set level (nom.) | 40 dBm | 31 dBm |
| AGC range | 15 dB | 20 dB |
| Impedance | 50 Ohms | |
| VSWR | <1.5:1 | |
| Rx/Tx Isolation | > 100 dB | |
| Fault Monitoring | LED indication for each fault | |
| Remote Alarm | Summarized alarm by dry contact | |
| Power Supply | AC 110/220V/50Hz Range: 176~264 V, 45~65Hz Option +28 VDC | |

Mechanical Specifications:

| | |
|----------------|--|
| Size | 400X400X300 mm approx. |
| RF Connectors | N-type Female |
| Weight | 30 kg. Approx. |
| Enclosure Type | Weatherproof Enclosure for Wall Mounted Installation |

Environmental Conditions:

| | |
|-------------------------|-------------------|
| Operating temperature | -30°C to +50°C |
| Humidity | 95% |
| Weatherproof conditions | Protected to IP65 |

MECHANICAL LAYOUT

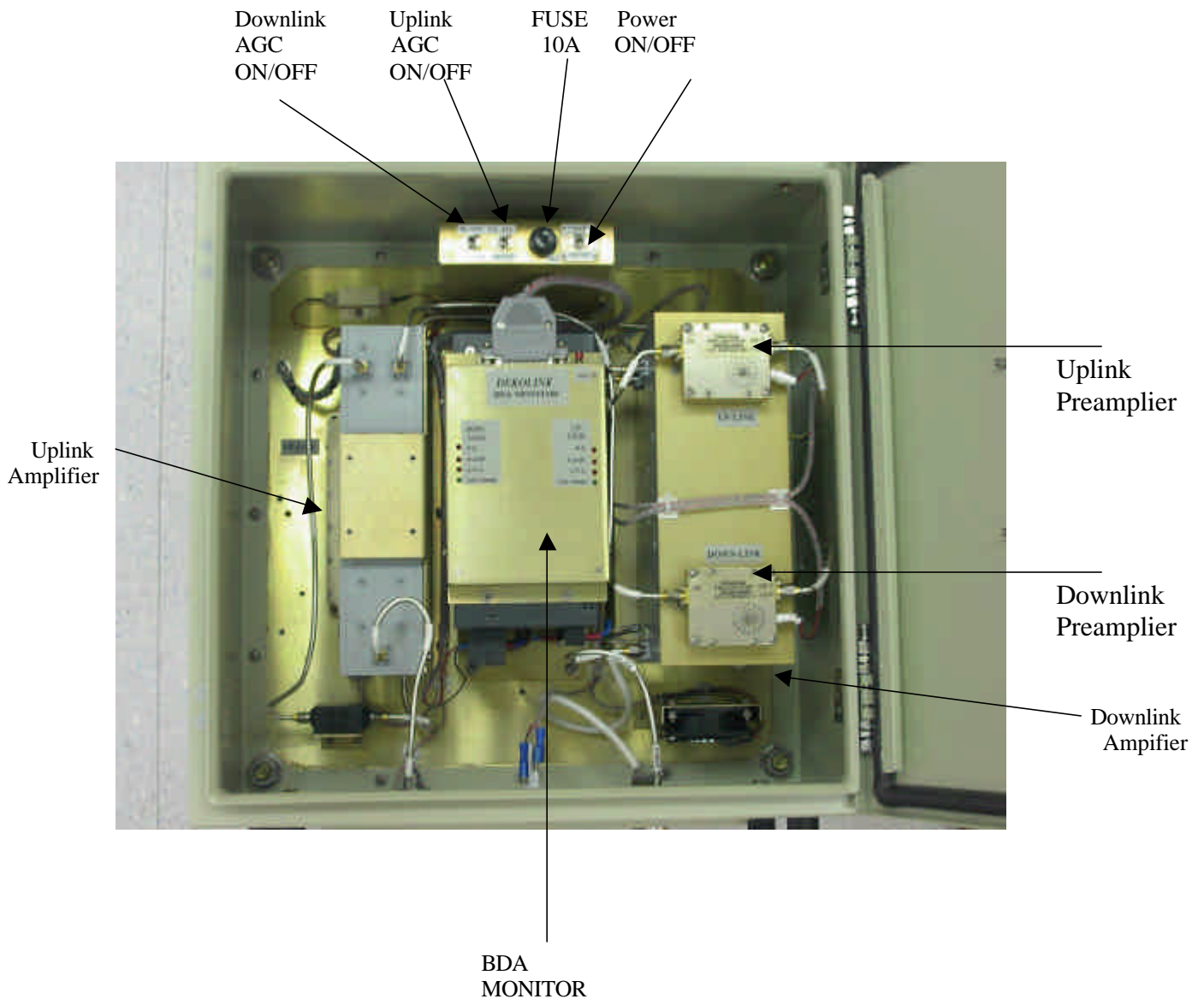



Dekolink WIRELESS Ltd.
16 Bazel St. Qiryat-Arieh Petah-Tikva, Israel, 49510
Tel- 972-3-9180-180 Fax-972-3-
e-mail: marketing@decolink.com web www.decolink.com

MECHANICAL OUTLINE

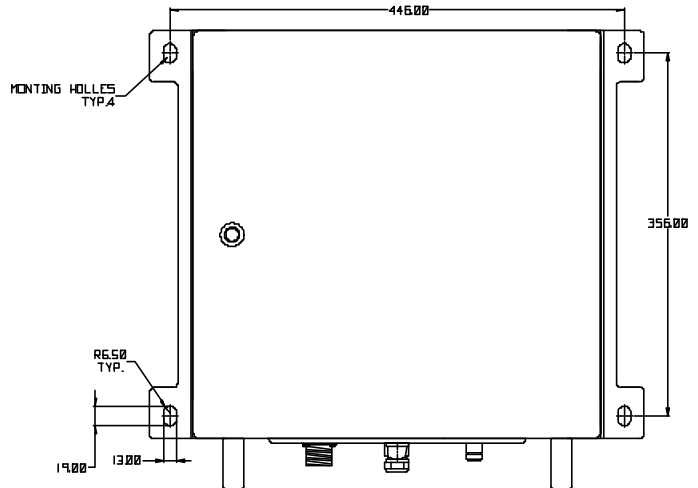
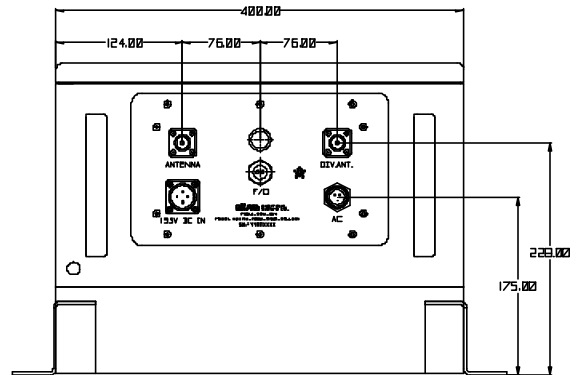
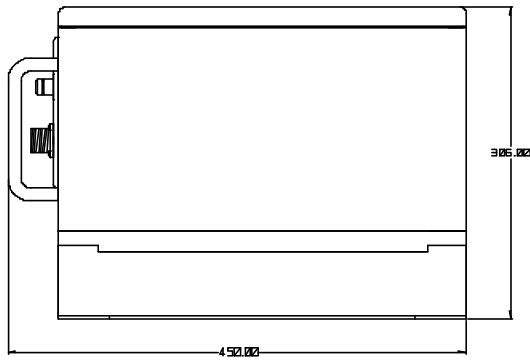



Dekolink WIRELESS Ltd.
16 Bazel St. Qiryat-Arieh Petah-Tikva, Israel, 49510
Tel- 972-3-9180-180 Fax-972-3- -
e-mail: marketing@decolink.com web www.decolink.com

DEKOLINK WIRELESS

LIMITED WARRANTY

Dekolink Wireless [Ltd.] ("Dekolink"), manufacturer of this product (the "Product") warrants to the original purchaser ("Purchaser") that the Product is free from defects in materials and workmanship for a term that ends on the earlier of twelve (12) months from the date of activation of the Product or fifteen (15) months from the date of shipment of the Product by Dekolink. The obligations of Dekolink under this warranty shall be limited solely to the repair or exchange or giving credit for, at the option of Dekolink, any Product that may prove defective in accordance with evidence satisfactory to Dekolink. Any repair or replacement of the Product by Dekolink shall not extend the original warranty period. This warranty is exclusive to the original Purchaser and is not assignable.

This warranty applies only upon the condition that the Product has been installed, maintained and operated under conditions of normal use. The provisions of this warranty shall not apply if, in Dekolink's judgment, the Product has been subject to misuse or neglect, damaged in an accident or by act of vandalism, or repaired or altered in any way that adversely affects its performance or reliability.

To obtain warranty service, Purchaser may, upon the prior written authorization of Dekolink or its authorized service representative, return the defective Product to Dekolink's authorized service center. All shipping and insurance charges are the sole responsibility of Purchaser and are not included in this warranty. Dekolink expressly excludes and disclaims all other warranties, including but not limited to any warranties of merchantability or fitness for a particular purpose.

Dekolink shall in no event be liable for any special, indirect, incidental, consequential or punitive damages or for loss, damage, or expense, including loss of use, profits, revenue, or goodwill, directly or indirectly arising from purchaser's use or inability to use the merchandise, or for loss or destruction of other property or from any other cause, even if Dekolink has been advised of the possibility of such damage. Some states do not allow the exclusion or limitation of incidental or consequential damages so these limitations may not apply under certain circumstances.

The liability of Dekolink shall in no event exceed an amount equivalent to the purchase price paid by the purchaser for the defective product.

This warranty shall not be extended, altered or varied except by a written instrument duly signed by Dekolink.