

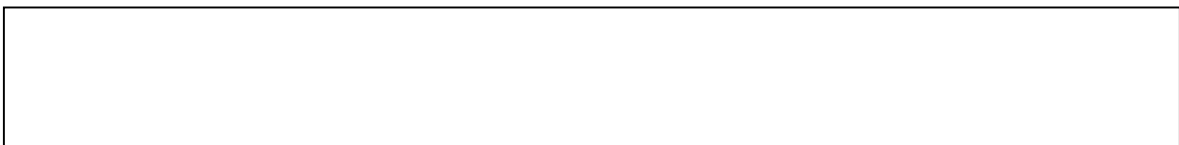

**ELISRA  
GROUP**

**Installation  
and  
Operating Instructions  
for  
MW-CBDA-SMR-800-900-1W80  
Dual Band  
Compact Bi-Directional Amplifier**





# ELISRA GROUP

## Table of Contents

Paragraph	Page No
CBDA Overview	3
Main Characteristics	3
Top Cover Alarm Indications	3
Remote Alarm Connector (back panel)	4
CBDA Indications and Control ( side windows)	4
Block Diagram Description	4
RF Block Diagram	5
Step Attenuator and RF Gain Setting	5
AGC Function	6
AGC & Gain Controls	6
AGC Amplifier Layout	6
CBDA Monitor and Alarm	7
CBDA Monitor and Alarm Function Block Diagram	8
CBDA Installation	9
Base / Donor Antenna Installation	9
Remote / Service Antenna Installation	9
Antenna Isolation	9
Installation Steps	10
Diagnostics Guide	11
Top Cover LED Indications	11
RF Faults and RF Power Amplifiers LED Indications:	12
Electrical Specifications	13
Environmental Conditions	14
Mechanical Specifications	14
RF Exposure Warning	14
Mechanical Outline	15
Dekolink Wireless Limited Warranty	16



**ELISRA  
GROUP**

## **CBDA Overview**

The Compact Bi-Directional Amplifier (CBDA) assembly provides exceptional repeater/booster performances to extend the coverage area of radio communications in buildings and RF shielded environments.

## **Main Characteristics**

- Covers both SMR 800 and SMR 900 in one product.
- 80 dB RF gain
- Over 24 dBm (1/4 Watt) downlink composite power.
- Alarm indication by LED and Dry contact
- Automatic power limit option
- Exceptionally high linear operation
- Ideal for in-building coverage solutions
- Relative small size and light weight
- Cost effective solution
- Wall mounted easy Installation
- Reliable operation, maintenance free

## **Top Cover Alarm Indications**

PWR: Power on green LED

UL: Illuminates at uplink power amplifier current fault

DL: Downlink RF power fault. Illuminates when the DL transmitted power is less than +15 dBm.



**ELISRA  
GROUP**

### **Remote Alarm Connector (back panel)**

Dry contact relay arms are connected to this D9 connector. The relay arms switch over at either one of the two alarms indicated on the top cover.

### **CBDA Indications and Control (side windows)**

These are reached by opening the window on the sides of the CBDA

AGC LED: This red led illuminates when the transmitted power is equal or higher than the composite power (factory preset at +24 dBm and DL).

AGC ON/OFF switch: Turns on the automatic power control.

**Warning: The AGC switch must be always ON in order to limit the spurious signals.**

Step attenuator: The CBDA gain can be stepped down by the amount indicated on the step attenuator.

### **Block Diagram Description**

The CBDA Downlink path receives TX signals from base station amplifies them and transmits them to the subscriber. The CBDA Uplink path receives RX signals from the subscriber amplifies them and transmits them to the base station. Two quad filter assemblies frequency separate the signals to the proper amplifying path and isolate the two signals.

Each path has two amplifiers; a low noise amplifier (LNA) and a high power amplifier. The low noise amplifier has a 30 dB step attenuator, which is used to set the repeater gain.

The power amplifiers in the CBDA have an AGC option switch. They also have a Power LED lamp that illuminates when the output power has reached the preset power limit.

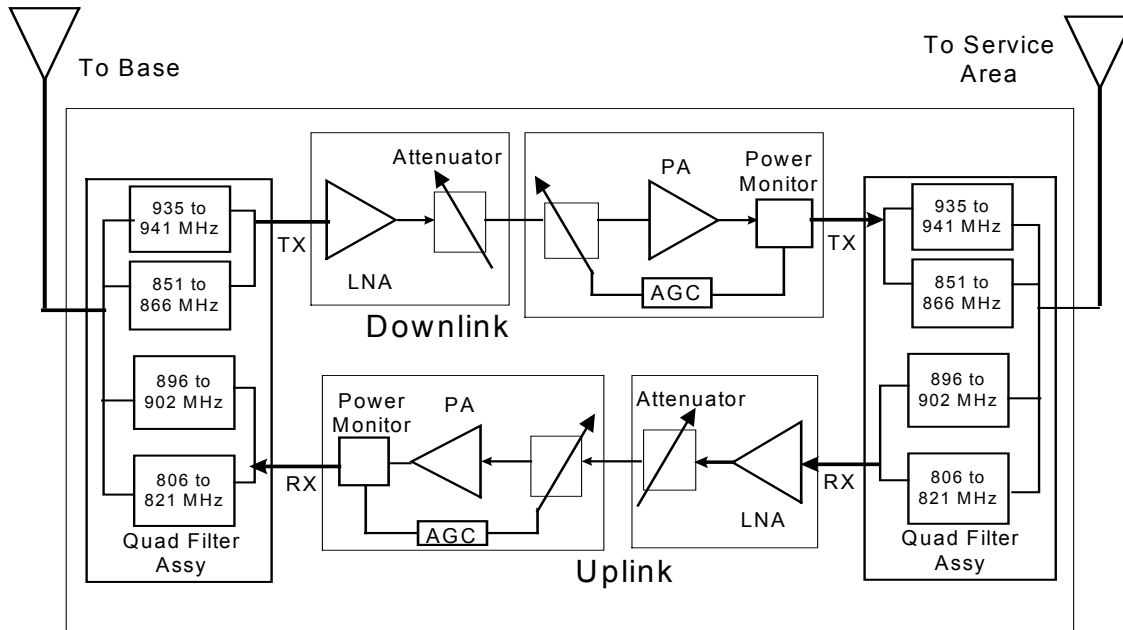

## RF Block Diagram

### Step Attenuator & RF Gain Setting

For proper operation of the CBDA; the isolation between the base station antenna and the mobile antenna should exceed the CBDA gain by at least 12 dB. If the CBDA gain were higher than the isolation between the antennas, oscillation would start and would saturate the amplifier. Isolation few dB higher than the CBDA gain cannot start oscillations but would cause gain ripple in the band.

The step attenuator on the low noise amplifier can reduce the CBDA gain. The CBDA gain can be stepped down by the amount indicated on the step attenuator (0 to 30 dB in 2 dB steps).



## AGC Function

The CBDA has AGC function on both paths that serve to prevent the saturation of the power amplifier. Their amplifier has a directional coupler and a detector at the output of the high power amplifier monitoring the output power. When a high signal is received the automatic level control detects the amplitude and sends a feedback signal to a voltage variable attenuator, which attenuates the signal level so that the output power of the amplifier does not exceed the preset limit. The LED on the amplifier illuminates when the power out the amplifier is within the set limit (when the AGC is On and when the AGC is OFF).

The switch on the RF amplifier enables the AGC function. If the AGC is disabled then the amplifier gives maximum gain and maximum power.

## AGC and Gain Controls

The AGC and GAIN SETTING functions for the up link path are reached by opening the small slide door located on the CBDA left side, adjacent to the BASE antenna port. For the down link path the door is on the right side adjacent to the MOBILE antenna port

**RF Power LED:** The LED illuminates when the output power exceeds the AGC Set.

**AGC ON / OFF Switch:** When OFF the amplifier works with its highest gain (AGC Function OFF). When set to ON (AGC Function ON) the amplifier power output cannot exceed the set limit.

**Warning:** The AGC switch must be always ON in order to limit the spurious signals.

**Gain setting:** By using the rotary knob, the attenuation can be adjusted from 0 to 30 dB in 2 dB steps.

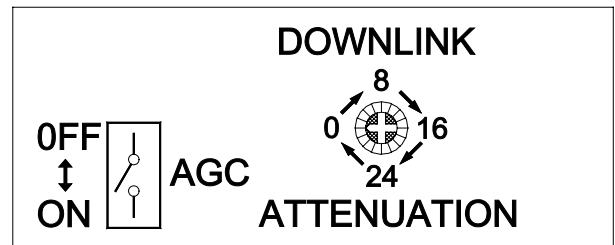
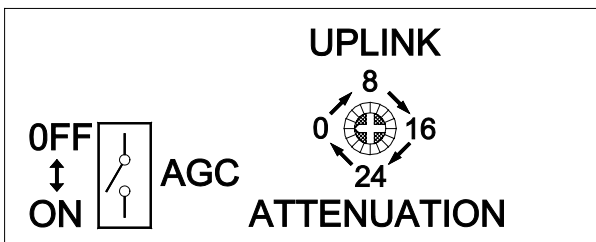



**ELISRA  
GROUP**

## **CBDA Monitor and Alarm**

The two main active elements are the Downlink Power Amplifier and the Uplink power amplifier. Each CBDA has a monitor circuit to monitor these elements and give alarm signal when there is a deviation from normal operation. The summarized alarm output of the monitor card is sent to a D-type connector on the front panel.

The monitor circuit performs the following functions:

- Monitors the current of uplink power amplifier. If the current is below or above the specified limits then an automatic alarm function is provided by a LED on the CBDA cover which illuminates and by dry contacts of a relay.
- Monitors the downlink RF output power. If the output power is over 10 dB below the rated value then an alarm function is provided by a LED on the CBDA cover which illuminates and by dry contacts of a relay.
- The relay arms are normally open, they close when power goes on (at no faults). Whenever any fault occurs or when the power is cut off from the CBDA the relay arms open. The relay arms are connected to pins 2,4 of a 9 pin D type male connector on the front panel of the CBDA for remote sensing of faults.  
Pin 2 and 3 of the D type connector provide complimentary relay alarm function; short at fault and open at no fault.
- The alarm LEDs (red) are displayed on the CBDA cover. The green led is power on indication.

**CBDA Monitor and Alarm Function**  
**Block Diagram**

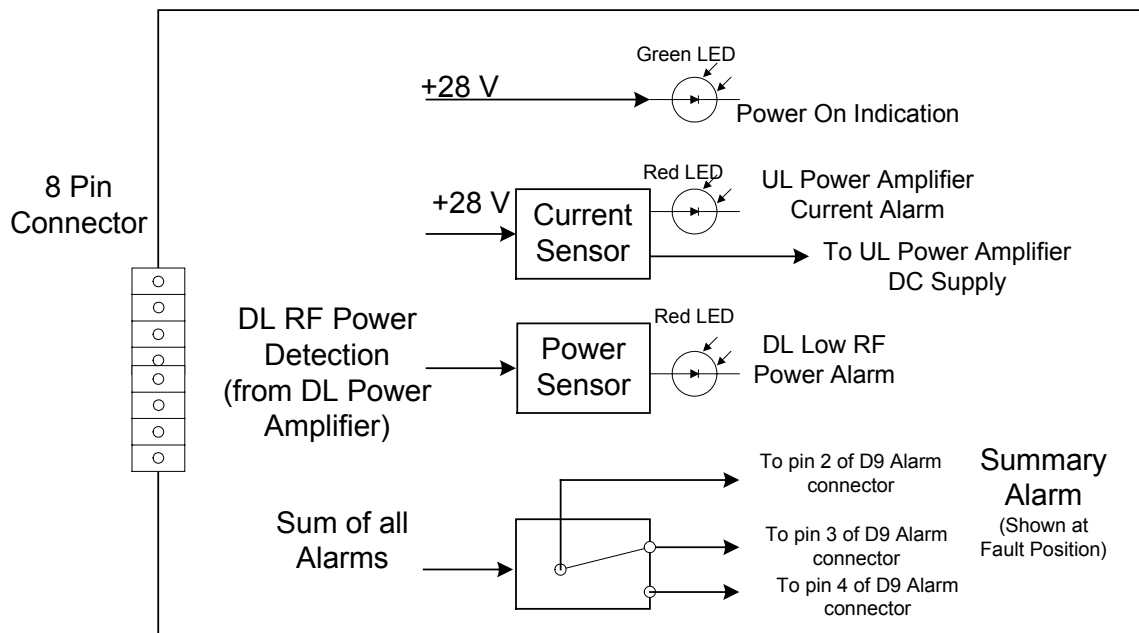

**Alarm relay connection to D connector:**  
 Pin 2 to 4 open at any fault; short at no fault  
 Pin 2 to 3 short at any fault; open at no fault





**ELISRA  
GROUP**

## **CBDA Installation**

Install the CBDA Repeater in a shielded, ventilated and easy to reach area. Use low loss cables to connect antennas to the CBDA. Install the CBDA close to the service area to improve output power and noise figure. Mount the CBDA with RF connectors pointing down. The RF connection is made via two type "N" female connectors. The RF connector labeled "Base" must be connected to the antenna; usually a Yagi; pointing to the base station. The RF connection labeled "Mobile" must be connected to the antenna pointing into the area to be covered by the CBDA.

**Note:** For cooling purposes The CBDA must be installed with the RF connectors facing down.

## **Base/ Donor Antenna Installation**

Typically this is a directional antenna such as Yagi or Dish antenna of 10 to 15 dB gain. This antenna is pointed to the base station to get maximum input power. This antenna should be in line of sight with the base site. Raise this antenna higher if no line of sight is achieved. The required Base signals should be the dominant signals; at least 6 dB higher power than other signals.

Choose the antenna site to get the maximum isolation from the remote (mobile serving) antenna.

## **Remote / Service Antenna Installation**

The remote antenna is an Omni antenna or a directional antenna according to the coverage requirements.

For indoor applications covering a large building, the RF signals are split using power dividers and distributed to many antennas each covering a floor or a small area.

## **Antenna Isolation**

For proper operation the isolation between these two antennas must be at least 12 dB higher than the CBDA gain. Lower isolation would lead to high in-band ripple. Oscillations will build up when the isolation is lower than CBDA gain.

The isolation between the antennas is critical for high gain outdoor repeaters.

To measure the isolation; inject a known signal into one antenna and measure the power at the other antenna. This should be done across the frequency range of both uplink and downlink bands.



**ELISRA  
GROUP**

## **Installation Steps**

1. Install all antennas and connect them to the CBDA inputs.
2. Open the access windows at the sides of the CBDA so that the variable attenuator is reached and the LED is visible.

Turn the AGC On. This AGC limits the output power of the CBDA. The AGC on the Downlink path guarantees constant downlink power when and if the Donor power changes.

**Warning: The AGC switch must be always ON in order to limit the spurious signals.**

3. Set downlink gain to minimum; uplink gain to minimum (by increasing the attenuation).
4. Increase the downlink channel gain (by decreasing the attenuation) till the LED turns from off to on. This is the best gain setting giving highest usable power. Higher gain setting will overdrive the AGC circuit.
5. The LED on the downlink power amplifier will illuminate if adequate donor (composite) power has reached the CBDA. If the donor power is low the LED will not lit and the CBDA usable power is not used efficiently.
6. The RF power alarm LED on the CBDA cover will lit if the downlink power is over 10 dB below the composite power.
7. Set the uplink gain to the same as the downlink gain.
8. Check that the uplink LED on the CBDA monitor does not lit permanently. This LED would lit permanently If the isolation between antennas is low (CBDA oscillations) or the CBDA is faulty.
9. If the uplink LED light permanently then:
  - Disconnect one of the cables from the CBDA connectors and connect a load at the connectors.
  - If the LED on this amplifier illuminates permanently then the CBDA is faulty (oscillating) and needs replacing.
  - If the LEDs stops illuminating then the isolation between the donor and remote antennas is low. Either improve the isolation (e.g. increase separation) or reduce CBDA gain.
  - To reduce gain, reconnect the antenna cables. Reduce the gain at both uplink and downlink path until this LED stops illuminating. Reduce the gain further by 10 dB. This is the maximum usable gain.



## **Diagnostic Guide**

The CBDA provides long term, carefree operation and requires no periodic maintenance.

This section covers possible problems related to the installation environment.

## **Top Cover LED Indications**

Once the CBDA is installed the red LEDs on the top cover indicate uplink and downlink faults.

The green LED is AC power on indication.

<b>Indication</b>	<b>Cause</b>	<b>Action</b>
Downlink LED (on cover) is ON	Indicates low RF power at downlink path <15 dBm)	Check base antenna connection. Check antenna alignment to base. Use higher gain BDA
Uplink Amp LED (on cover) is ON	Uplink amplifier over current or undercurrent fault	Replace CBDA

These faults can be sensed remotely from the dry contact relay arms wired to the D9 connector at the back of the CBDA.

### **Alarm relay connection to D connector:**

Pin 2 to 4 open at any fault; short at no fault

Pin 2 to 3 short at any fault; open at no fault



**RF Faults and RF Power Amplifiers LED Indications**

The LED on each power amplifiers is set to turn on when the transmitted power has reached or exceeded the specified composite power.

Normally the LED at the downlink power amplifier should be ON indicating good forward power transmission. The LED on the uplink power amplifier turns on only when a near by mobile is transmitting.

<b>Indication</b>	<b>Cause</b>	<b>Action</b>
Downlink LED (on amplifier) does not light	Indicates low RF power at downlink path (below AGC setting)	Check base antenna connection Check antenna alignment to base. Increase CBDA RF gain.
Downlink LED (on amplifier) lights  (This is not a fault)	Indicates good power transmission in the downlink amplifier.  Make sure the amplifier is not overloaded	Turn AGC on, or reduce gain so that LED just turns from off to on.  Set the same gain for the uplink channel
Uplink LED (on amplifier) lights all the time	Bad antenna isolation causing the repeater system to oscillate	Improve the isolation between the antennas or reduce RF gain. To verify disconnect one RF port; LED should turn off
Uplink LED (on amplifier) lights all the time	Faulty system. Can be quad filter assembly or power amplifier fault	System fault. To verify disconnect one RF port to verify. If LED remains on then system is faulty.
Excessive intermodulation or spurious	Amplifier oscillation caused by insufficient isolation	Improve the isolation between the antennas or reduce RF gain.
Excessive noise in downlink	High input power causing amplifier overload	Turn AGC on, or reduce gain so that LED just turns from off to on. Set the same gain for the uplink channel



## Electrical Specifications

Downlink frequency range	851- 869 MHz 935 - 941 MHz
Uplink frequency range	806 - 824 MHz 896 - 902 MHz
Pass band gain @min attenuation	80 dB nominal
Pass band ripple	± 2 dB typical
Manual attenuation range	0 to 30 dB in 2 dB step
Noise figure @max gain	6.0 dB max
V.S.W.R In/Out	1.5: 1 max
AGC selection	By ON/OFF Switch
AGC attenuation range	25 dB typical
AGC LED indication	LED turn ON when power reaches AGC Set Power Level. (both at On and Off positions).
Composite power	+25 dBm nom.
AGC factory power preset	+24 dBm nom.
3rd Order output spurious	48 dBc typical for 2 signals +20 dBm each
3rd Order output Intercept point	+44 dBm typical
Downlink alarm turn on	DL power <15 dBm
Power Supply	110/220V AC, 50-60 Hz /50 Watt



**ELISRA  
GROUP**

## **Environmental Conditions**

Operating temperature	0°C to + 50°C
Storage temperature	- 50°C to + 90°C

## **Mechanical Specifications**

Size mm(Inch)	330(13) x 300(11.8) x190(7.5)
RF Connectors	N-type Female
Weight	14 kg. (31 lb.) Approx

## **RF Exposure Warning**

In order to satisfy the FCC RF exposure requirements, you must ensure that the installation complies with the following:

One antenna is connected via cable that has typical 1~10 dB attenuation (depends on the length of the cable) to the CBDA BASE port. This antenna is installed outdoor and has very sharp beam (Yagi type or similar) pointed to the donor (BTS). This type of antenna has about 10 dBi gain. Typical specifications: gain: 8 dBd (=10.1 dBi), VSWR: better than 1.5:1 , Impedance: 50 ohm. The outdoor antenna must be installed to provide a minimum separation distance of 0.5 m (50 cm) from persons within the area.

The second antenna is connected via cable that has typical 1~10 dB attenuation (depends on the length of the cable) to the CBDA MOBILE port. This type of antenna is omni-directional (isotropic), or wide beam, with 0 to 2 dBi typical gain and is installed and distributes indoor (in buildings, tunnels, basements, park lots, shopping centers etc.). Typical specifications: gain: 2 dBi, VSWR: better than 2:1 , Impedance: 50 ohm. The indoor antenna must be installed to provide a minimum separation distance of 0.2 m (20 cm) from persons within the area.



**ELISRA  
GROUP**

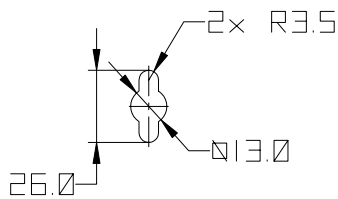
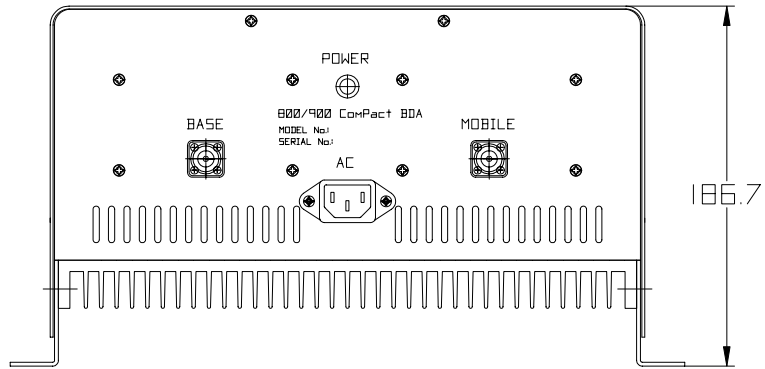

DETAIL A  
TYP.4

Install this way up with RF connectors facing down

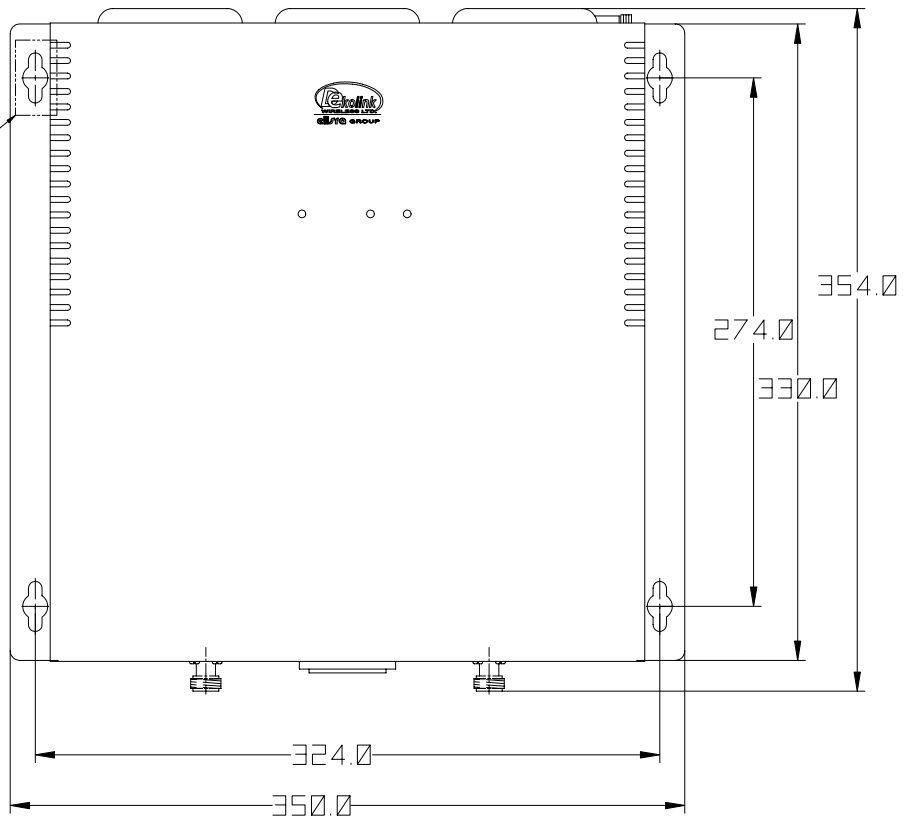

**Mechanical Outline**



**ELISRA  
GROUP**

## **DEKOLINK WIRELESS LIMITED WARRANTY**

Dekolink Wireless [Ltd.] ("Dekolink"), manufacturer of this product (the "Product") warrants to the original purchaser ("Purchaser") that the Product is free from defects in materials and workmanship for a term that ends on the earlier of twelve (12) months from the date of activation of the Product or fifteen (15) months from the date of shipment of the Product by Dekolink. The obligations of Dekolink under this warranty shall be limited solely to the repair or exchange or giving credit for, at the option of Dekolink, any Product that may prove defective in accordance with evidence satisfactory to Dekolink. Any repair or replacement of the Product by Dekolink shall not extend the original warranty period. This warranty is exclusive to the original Purchaser and is not assignable.

This warranty applies only upon the condition that the Product has been installed, maintained and operated under conditions of normal use. The provisions of this warranty shall not apply if, in Dekolink's judgment, the Product has been subject to misuse or neglect, damaged in an accident or by act of vandalism, or repaired or altered in any way that adversely affects its performance or reliability.

To obtain warranty service, Purchaser may, upon the prior written authorization of Dekolink or its authorized service representative, return the defective Product to Dekolink's authorized service center. All shipping and insurance charges are the sole responsibility of Purchaser and are not included in this warranty. Dekolink expressly excludes and disclaims all other warranties, including but not limited to any warranties of merchantability or fitness for a particular purpose.

Dekolink shall in no event be liable for any special, indirect, incidental, consequential or punitive damages or for loss, damage, or expense, including loss of use, profits, revenue, or goodwill, directly or indirectly arising from purchaser's use or inability to use the merchandise, or for loss or destruction of other property or from any other cause, even if Dekolink has been advised of the possibility of such damage. Some states do not allow the exclusion or limitation of incidental or consequential damages so these limitations may not apply under certain circumstances.

The liability of Dekolink shall in no event exceed an amount equivalent to the purchase price paid by the purchaser for the defective product.

This warranty shall not be extended, altered or varied except by a written instrument duly signed by Dekolink.