

**INSTALLATION
AND
OPERATING INSTRUCTIONS
FOR
MW-CBDA-ESMR-10W80-A
MW-CBDA-ESMR-1W80-A
COMPACT BI-DIRECTIONAL
AMPLIFIERS**



TABLE OF CONTENTS

PARAGRAPH	PAGE No
BDA OVERVIEW	3
BLOCK DIAGRAM DESCRIPTION	3
BDA OPERATION	4
STEP ATTENUATOR & RF GAIN & SETTING	4
AGC FUNCTION	5
AGC AMPLIFIER CONTROLS	5
RF EXPOSURE WARNING	6
ELECTRICAL SPECIFICATIONS	7
ENVIRONMENTAL CONDITIONS	7
MECHANICAL SPECIFICATIONS	8

LIST OF DRAWINGS

DRAWING	PAGE No
BDA RF BLOCK DIAGRAM	4
AGC AMPLIFIER	5
MECHANICAL OUTLINE	8

BDA OVERVIEW:

The Compact Bi-Directional Amplifier (CBDA) assembly provides an exceptional repeater/booster performances to extend the coverage area of radio communications in buildings and RF shielded environments.

Features such as high linearity power amplifiers are contributing for the overall improved system linearity performances. The unit is based on a duplexed path configuration, having sharp out of band attenuation for improved isolation between the receiving and transmitting paths.

BLOCK DIAGRAM DESCRIPTION:

The CBDA Downlink path receives the RF signals from base station amplifies them and transmits them to the subscriber. The BDA Uplink path receives the RF signals from the subscriber amplifies them and transmits them to the base station. Two duplexers frequency separate the signals to the proper amplifying path and isolate the two signals.

For each path two amplifiers do the path signal amplification; a low noise amplifier (LNA) and a high power amplifier. The low noise amplifier has a 30 dB step attenuator at its output. The step attenuator is used to set the BDA repeater gain.

The power amplifiers in the BDA have an AGC option switch. When switched on, the AGC circuit limits the amplifier output power. The AGC circuit senses the output power and introduces more attenuation, when the output power exceeds the preset level. This way the gain of the amplifier is reduced, its output power is limited and the intermodulations products are kept below the desired level.

The AGC amplifier has a Power LED lamp that illuminates when the output power has reached the preset power limit.

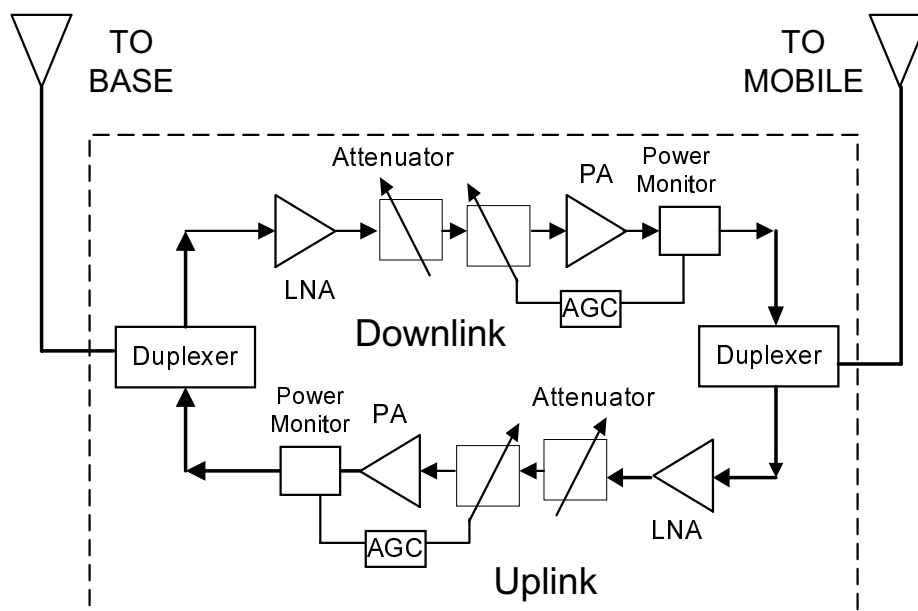

BDA RF BLOCK DIAGRAM

BDA OPERATION

The RF connection is made via two type “N” female connectors. The RF connector labeled “Base” must be connected to the antenna pointing to the base station; usually a rooftop antenna. The RF connection labeled “Mobile” must be connected to the antenna pointing into the area to be covered by the BDA; such as inside a building.

Step Attenuator & RF Gain Setting

For proper operation of the BDA; the isolation between the base station antenna and the mobile antenna should exceed the BDA gain by at least 12 dB. If the BDA gain were higher than the isolation between the antennas, oscillation would start and would saturate the amplifier. Isolation few dB higher than the BDA gain cannot start oscillations but would cause gain ripple in the band.

The step attenuator on the low noise amplifier can reduce the BDA gain. The BDA gain can be stepped down by the amount indicated on the step attenuator.

AGC FUNCTION

The BDA has AGC function on both paths that serve to prevent the saturation of the power amplifier. Their amplifier has a directional coupler and a detector at the output of the high power amplifier to monitor the output power. When a high signal is received the automatic level control detects the amplitude and sends a feedback signal to a voltage variable attenuator which attenuates the signal level so that the output power of the amplifier does not exceed the preset limit. The LED on the amplifier illuminates when the power out the amplifier is within the set limit (when the AGC is On and when the AGC is OFF).

The switch on the RF amplifier enables the AGC function. If the AGC is disabled then the amplifier gives maximum gain.

Note: The BDA is shipped with the AGC switch in the OFF position.

The screw on the amplifier is used to set the AGC power limit. This is a factory-preset level.

AGC AND GAIN CONTROLS

The AGC and GAIN SETTING functions for the up link path are reached by opening the small slide door located on the CBDA left side, adjacent to the BASE antenna port. For the down link path the door is on the right side adjacent to the MOBILE antenna port

RF Power LED: The LED illuminates when the output power exceeds the AGC Set .

AGC ON / OFF Switch: When OFF the amplifier works with its highest gain (AGC Function OFF). When set to ON (AGC Function ON) the amplifier power output cannot exceed the set limit.

Gain setting: By using the rotary knob , the attenuation can be adjusted in 2 dB steps.

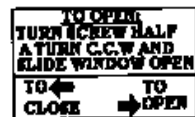
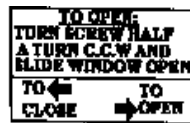

RF EXPOSURE WARNING

In order to satisfy the FCC RF exposure requirements, you must ensure that the installation complies with the following:

One antenna is connected via cable that has typical 1~10 dB attenuation (depends on the length of the cable) to the BDA BASE port. This antenna is installed outdoor and has very sharp beam (Yagi type or similar) pointed to the donor (BTS). This type of antenna has about 10 dBi gain. Typical specifications: gain: 8 dBd (=10.1 dBi), VSWR: better than 1.5:1 , Impedance: 50 ohm. The outdoor antenna must be installed to provide a minimum separation distance of 0.3 m (30 cm) from persons within the area.

The second antenna is connected via cable that has typical 1~10 dB attenuation (depends on the length of the cable) to the CBDA MOBILE port. This type of antenna is omnidirectional (isotropic), or wide beam, with 0 to 2 dBi typical gain and is installed and distributes indoor (in buildings, tunnels, basements, park lots, shopping centers etc.). Typical specifications: gain: 2 dBi, VSWR: better than 2:1 , Impedance: 50 ohm.

For CBDA-1W80 the indoor antenna must be installed to provide a minimum separation distance of 0.2 m (20 cm) from persons within the area.

For CBDA-10W80 the output power can be distributed to several antennas.

For single indoor antenna, the antenna must be installed to provide a minimum separation distance of 0.5 m (50 cm) from persons within the area.

When 4 antennas (or more) are used, the indoor antenna must be installed to provide a minimum separation distance of 0.2 m (20 cm) from persons within the area.

ELECTRICAL SPECIFICATIONS:

Frequency Range (MHz)	Up link: 806-821MHz. Down link : 851-866 MHz
Passband Gain @Min attenuation	80 dB nominal
Passband Ripple	± 1.5 dB typical
Manual Attenuation Range	0 to 30 dB in 2 dB step
Noise Figure	6.0 dB max
Impedance level	50 ohms
V.S.W.R In/Out	1.5 : 1 max
AGC Selection	By ON/OFF Switch
AGC Attenuation Range	25 dB typical
AGC LED Indication	LED turn ON when power reaches AGC Set Power Level. (both at On and Off positions).
AGC Factory Power Preset	Up link: +24 dBm nom. Down link - for CBDA 10W :+30 dBm nom. - for CBDA 1W : +24 dBm nom.
Amplifier Power Output @1 dB Compression	Up Link : 1 Watts Down Link - for CBDA 10W :10 Watts - for CBDA 1W : 1 Watt
3rd Order output Intercept point	Up Link : +45 dBm typical Down Link - for CBDA 10W :+50 dBm typical - for CBDA 1W : +45 dBm typical
Power Supply	110/220V AC, 50-60 Hz /1A

ENVIRONMENTAL CONDITIONS:

Operating temperature	: - 30 C to + 50 C
Storage temperature	: - 50 C to + 90 C

Mechanical Specifications:

Size mm(Inch)	265(10.4) x 250(9.8) x140(5.5)
RF Connectors	N-type Female
Weight	8 kg. Approx

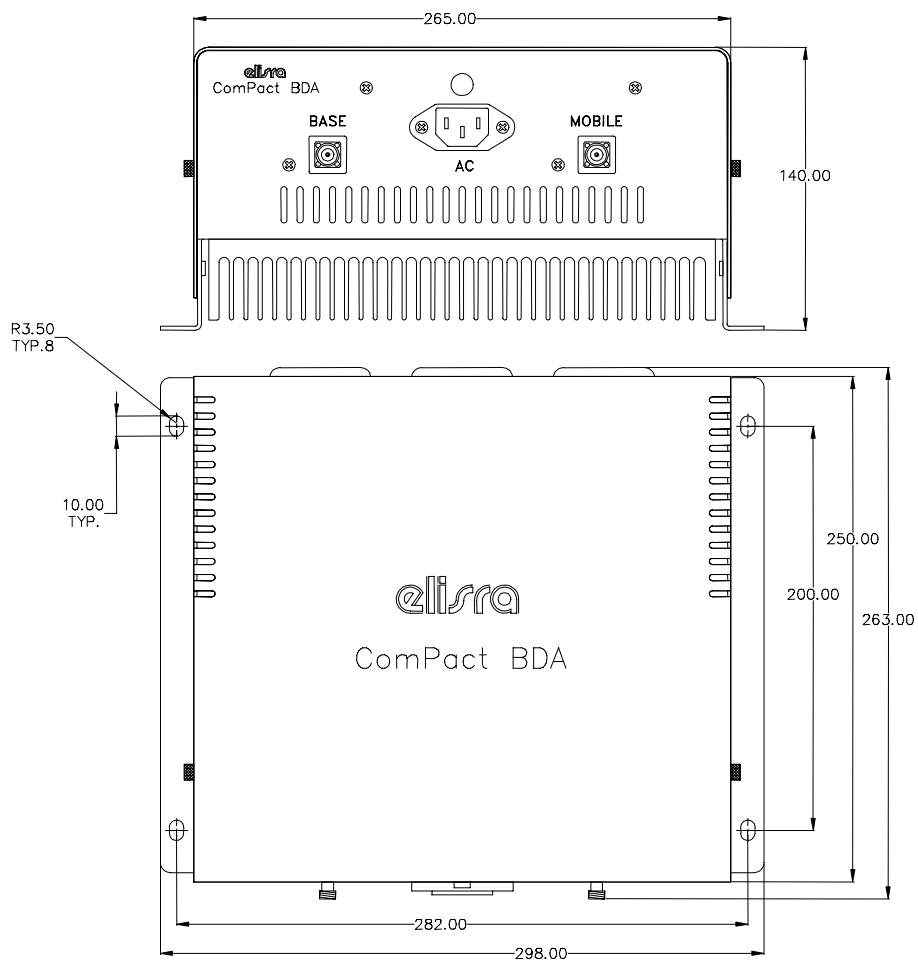

MECHANICAL OUTLINE