



**ELISRA  
GROUP**

**INSTALLATION  
AND  
OPERATING INSTRUCTIONS  
FOR  
MW-CBDA SERIES 1W-80-A  
COMPACT BI-DIRECTIONAL  
AMPLIFIERS**





# ELISRA GROUP

## INSTALLATION & OPERATING INSTRUCTIONS

### CBDA 1W-80-A COMPACT BI-DIRECTIONAL AMPLIFIERS

## TABLE OF CONTENTS

PARAGRAPH	PAGE No
BDA OVERVIEW	3
BLOCK DIAGRAM DESCRIPTION	3
STEP ATTENUATOR & RF GAIN & SETTING	4
AGC FUNCTION	5
AGC & GAIN CONTROLS	5
BDA INSTALLATION	6
BASE/DONOR ANTENNA INSTALLATION	6
REMOTE/MOBILE ANTENNA INSTALLATION	6
ANTENNA ISOLATION	6
INSTALLATION STEPS	7
DIAGNOSTICS GUIDE	8
ELECTRICAL SPECIFICATIONS	9
SYSTEM FREQUENCY RANGE	9
ENVIRONMENTAL CONDITIONS	10
MECHANICAL SPECIFICATIONS	10
RF EXPOSURE WARNING	10
LIMITED WARRANTY	12

## LIST OF DRAWINGS

DRAWING	PAGE No
BDA RF BLOCK DIAGRAM	4
AGC AMPLIFIER	5
MECHANICAL OUTLINE	11



**ELISRA  
GROUP**

## **BDA OVERVIEW:**

The Compact Bi-Directional Amplifier (CBDA) assembly provides an exceptional repeater/booster performances to extend the coverage area of radio communications in buildings and RF shielded environments.

Features such as high linearity power amplifiers are contributing for the overall improved system linearity performances. The unit is based on a duplexed path configuration, having sharp out of band attenuation for improved isolation between the receiving and transmitting paths.

## **BLOCK DIAGRAM DESCRIPTION:**

The CBDA Downlink path receives the RF signals from base station amplifies them and transmits them to the subscriber. The BDA Uplink path receives the RF signals from the subscriber amplifies them and transmits them to the base station. Two duplexers frequency separate the signals to the proper amplifying path and isolate the two signals.

For each path two amplifiers do the path signal amplification; a low noise amplifier (LNA) and a high power amplifier. The low noise amplifier has a 30 dB step attenuator at its output. The step attenuator is used to set the BDA repeater gain.

The power amplifiers in the BDA have an AGC option switch. When switched on, the AGC circuit limits the amplifier output power. The AGC circuit senses the output power and introduces more attenuation, when the output power exceeds the preset level. This way the gain of the amplifier is reduced, its output power is limited and the intermodulations products are kept below the desired level.

The AGC amplifier has a Power LED lamp that illuminates when the output power has reached the preset power limit.

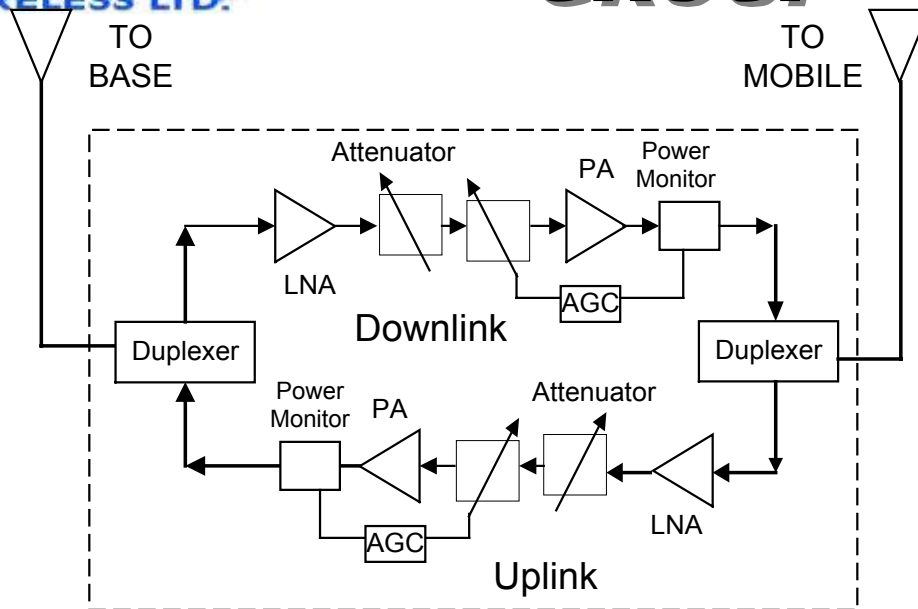

## BDA RF BLOCK DIAGRAM

### Step Attenuator & RF Gain Setting

For proper operation of the BDA; the isolation between the base station antenna and the mobile antenna should exceed the BDA gain by at least 12 dB. If the BDA gain were higher than the isolation between the antennas, oscillation would start and would saturate the amplifier. Isolation few dB higher than the BDA gain cannot start oscillations but would cause gain ripple in the band.

The step attenuator on the low noise amplifier can reduce the BDA gain. The BDA gain can be stepped down by the amount indicated on the step attenuator.



# ELISRA GROUP

## AGC FUNCTION

The BDA has AGC function on both paths that serve to prevent the saturation of the power amplifier. Their amplifier has a directional coupler and a detector at the output of the high power amplifier to monitor the output power. When a high signal is received the automatic level control detects the amplitude and sends a feedback signal to a voltage variable attenuator which attenuates the signal level so that the output power of the amplifier does not exceed the preset limit. The LED on the amplifier illuminates when the power out the amplifier is within the set limit (when the AGC is On and when the AGC is OFF).

The switch on the RF amplifier enables the AGC function. If the AGC is disabled then the amplifier gives maximum gain.

## AGC AND GAIN CONTROLS

The AGC and GAIN SETTING functions for the up link path are reached by opening the small slide door located on the CBDA left side, adjacent to the BASE antenna port. For the down link path the door is on the right side adjacent to the MOBILE antenna port

**RF Power LED:** The LED illuminates when the output power exceeds the AGC Set .

**AGC ON / OFF Switch:** When OFF the amplifier works with its highest gain (AGC Function OFF). When set to ON (AGC Function ON) the amplifier power output cannot exceed the set limit.

**Warning:** The AGC switch must be always ON in order to limit the spurious signals.

**Gain setting:** By using the rotary knob , the attenuation can be adjusted in 2 dB steps.

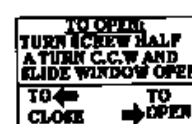
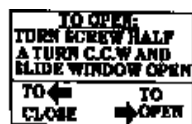



**ELISRA  
GROUP**

## **BDA INSTALLATION**

Install the BDA Repeater in a shielded, ventilated and easy to reach area. Use low loss cables to connect antennas to the BDA. Install the BDA close to the service area to improve output power and noise figure. Mount the BDA with RF connectors pointing down. The RF connection is made via two type "N" female connectors. The RF connector labeled "Base" must be connected to the antenna; usually a Yagi; pointing to the base station. The RF connection labeled "Mobile" must be connected to the antenna pointing into the area to be covered by the BDA.

## **BASE / DONOR ANTENNA INSTALLATION**

Typically this is a directional antenna such as Yagi or Dish antenna of 10 to 15 dB gain. This antenna is pointed to the base station to get maximum input power. This antenna should be in line of sight with the base site. Raise this antenna higher if no line of sight is achieved. The required Base signals should be the dominant signals; at least 6 dB higher power than other signals.

Choose the antenna site to get the maximum isolation from the remote (mobile serving) antenna.

## **REMOTE / MOBILE ANTENNA INSTALLATION**

The remote antenna is an Omni antenna or a directional antenna according to the coverage requirements.

For indoor applications covering a large building, the RF signals are split using power dividers and distributed to many antennas each covering a floor or a small area.

## **ANTENNA ISOLATION**

For proper operation the isolation between these two antennas must be at least 12 dB higher than the BDA gain. Lower isolation would lead to high in-band ripple. Oscillations will build up when the isolation is lower than BDA gain.

The isolation between the antennas is critical for high gain outdoor repeaters.

To measure the isolation; inject a known signal into one antenna and measure the power at the other antenna. This should be done across the frequency range of both uplink and downlink bands.



**ELISRA  
GROUP**

## **INSTALLATION STEPS**

1. Install all antennas and connect them to the BDA inputs.
2. Open the access windows at the sides of the BDA so that the variable attenuator is reached and the LED is visible.

Turn the AGC On. This AGC limits the output power of the BDA. The AGC on the Downlink path guarantees constant downlink power when and if the Donor power changes.

**Warning: The AGC switch must be always ON in order to limit the spurious signals.**

3. Set downlink gain to minimum; uplink gain to minimum (by increasing the attenuation).
4. Increase the downlink channel gain (by decreasing the attenuation) till the LED turns from off to on. This is the best gain setting giving highest usable power.
5. The LED on the downlink power amplifier will illuminate if adequate donor power has reached the BDA. If the donor power is low the LED will not lit and the BDA usable power is not used efficiently.
6. Set the uplink gain to the same as the downlink gain.
7. Check that the uplink LED on the BDA monitor does not lit permanently. This LED would lit permanently If the isolation between antennas is low (BDA oscillations) or the BDA is faulty.
8. If the uplink LED light permanently then:
  - Disconnect one of the cables from the BDA connectors and connect a load at the connectors.
  - If the LED on this amplifier illuminates permanently then the BDA is faulty (oscillating) and needs replacing.
  - If the LEDs stops illuminating then the isolation between the donor and remote antennas is low. Either improve the isolation (e.g. increase separation) or reduce BDA gain.
  - To reduce gain, reconnect the antenna cables. Reduce the gain at both uplink and downlink path until this LED stops illuminating. Reduce the gain further by 10 dB. This is the maximum usable gain.



**DIAGNOSTICS GUIDE**

The BDA provides long term, carefree operation and requires no periodic maintenance.

This section covers possible problems related to the installation environment.

**RF Faults and RF Power Amplifiers LED Indications:**

The LEDs on the power amplifier are set to turn on when the transmitted power has reached or exceeded the specified composite power.

Normally the LED at the downlink power amplifier should be on indicating good forward power transmission. The LED on the uplink power amplifier turns on only when a near by mobile is transmitting.

<b>Indication</b>	<b>Cause</b>	<b>Action</b>
Downlink LED does not light	Indicates low RF power at downlink path	Check base antenna connection Check antenna alignment to base. Increase BDA RFgain.
Downlink LED lights (This is not a fault)	Indicates good power transmission in the downlink amplifier. Make sure the amplifier is not overloaded	Turn AGC on, or reduce gain so that LED just turns from off to on. Set the same gain for the uplink channel
Uplink LED lights all the time	Bad antenna isolation causing the repeater system to oscillate	Improve the isolation between the antennas or reduce RF gain. To verify disconnect one RF port; LED should turn off
Uplink LED lights all the time	Faulty system. Can be diplexer or power amplifier fault	System fault. To verify disconnect one RF port to verify. If LED remains on then system is faulty.
Excessive intermodulation or spurious	Amplifier oscillation caused by insufficient isolation	Improve the isolation between the antennas or reduce RF gain.
Excessive noise in downlink	High input power causing amplifier overload	Turn AGC on, or reduce gain so that LED just turns from off to on. Set the same gain for the uplink channel





**ELECTRICAL SPECIFICATIONS:**

Frequency Range (MHz)	SEE TABLE
Passband Gain @Min attenuation	80 dB nominal
Passband Ripple	± 1.5 dB typical
Manual Attenuation Range	0 to 30 dB in 2 dB step
Noise Figure	6.0 dB max
Impedance level	50 ohms
V.S.W.R In/Out	1.5 : 1 max
AGC Selection	By ON/OFF Switch
AGC Attenuation Range	25 dB typical
AGC LED Indication	LED turn ON when power reaches AGC Set Power Level. (both at On and Off positions).
AGC Factory Power Preset	+24 dBm nom.
Amplifier Power Output @1 dB Compression	1 Watts
3rd Order output Intercept point	+45 dBm typical
Power Supply	110/220V AC, 50-60 Hz /1A

**System Frequency Range**

SYSTEM TYPE	MODEL No	DOWN-LINK	UP-LINK
E-SMR (iDEN)	MW-CBDA-ESMR-1W80A	851-866	806-821
<b>SMR 800-Public Safety</b>	<b>MW-CBDA-SMR-1W80A-PS8</b>	<b>851-869</b>	<b>806-824</b>
SMR - 900 MHz	MW-CBDA-SMR-1W80A-PS9	935-941	892-902
GSM	MW-CBDA-GSM-1W80A	935-960	890-915
TDMA Band B	MW-CBDA-CELLB-1W80A	880-894	835-849
CDMA/TDMA/N-AMPS	MW-CBDA-AB-1W80A	870-894	825-849



**ELISRA  
GROUP**

## **ENVIRONMENTAL CONDITIONS:**

Operating temperature	- 30°C to + 50°C
Storage temperature	- 50°C to + 90°C

## **MECHANICAL SPECIFICATIONS:**

Size mm(Inch)	265(10.4) x 250(9.8) x140(5.5)
RF Connectors	N-type Female
Weight	8 kg. Approx

## **RF EXPOSURE WARNING**

In order to satisfy the FCC RF exposure requirements, you must ensure that the installation complies with the following:

One antenna is connected via cable that has typical 1~10 dB attenuation (depends on the length of the cable) to the BDA BASE port. This antenna is installed outdoor and has very sharp beam (Yagi type or similar) pointed to the donor (BTS). This type of antenna has about 10 dBi gain. Typical specifications: gain: 8 dBd (=10.1 dBi), VSWR: better than 1.5:1 , Impedance: 50 ohm. The outdoor antenna must be installed to provide a minimum separation distance of 0.3 m (30 cm) from persons within the area.

The second antenna is connected via cable that has typical 1~10 dB attenuation (depends on the length of the cable) to the CBDA MOBILE port. This type of antenna is omnidirectional (isotropic), or wide beam, with 0 to 2 dBi typical gain and is installed and distributes indoor (in buildings, tunnels, basements, park lots, shopping centers etc.). Typical specifications: gain: 2 dBi, VSWR: better than 2:1 , Impedance: 50 ohm. The indoor antenna must be installed to provide a minimum separation distance of 0.2 m (20 cm) from persons within the area.

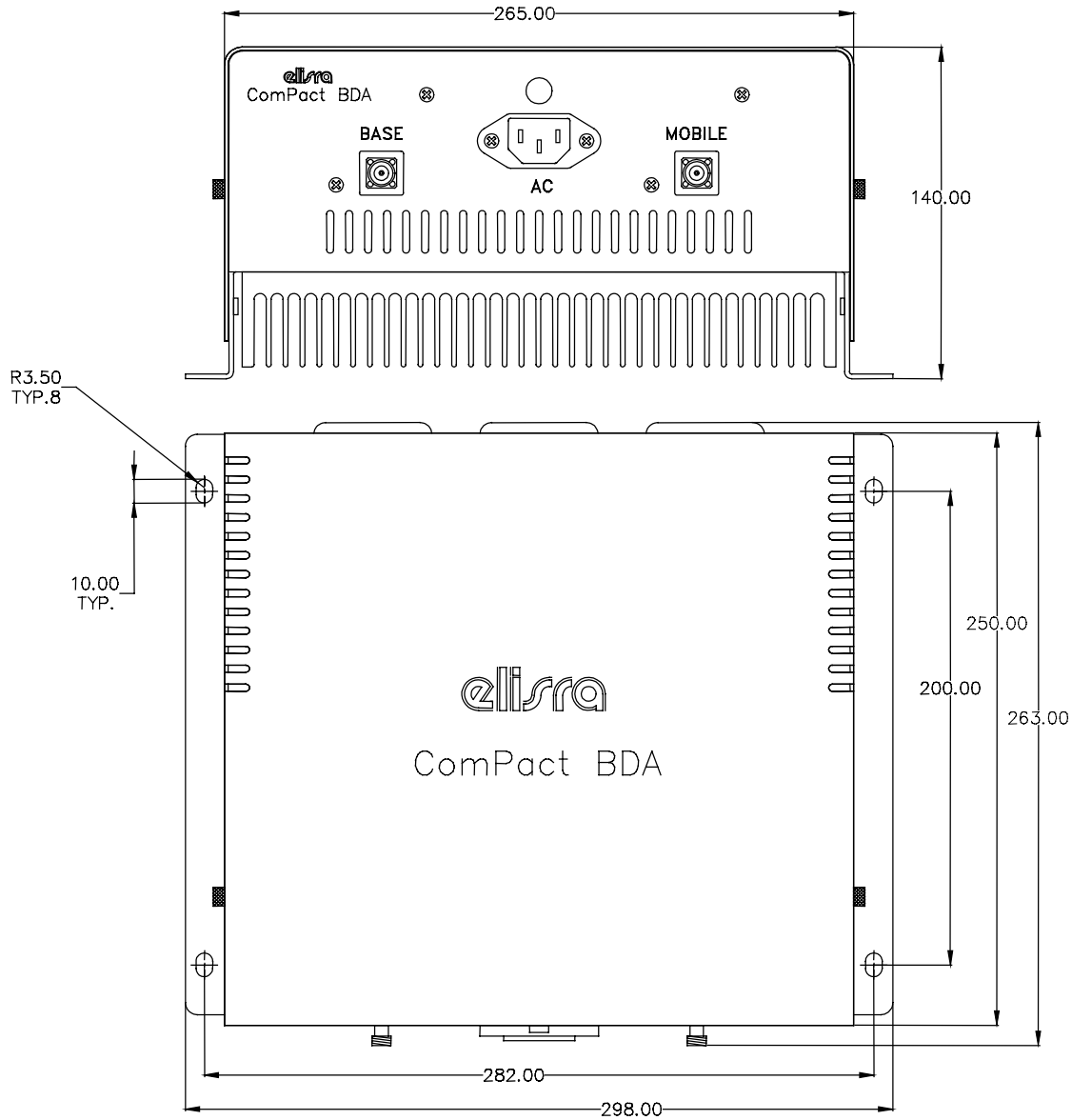

## MECHANICAL OUTLINE



**ELISRA  
GROUP**

## **DEKOLINK WIRELESS LIMITED WARRANTY**

Dekolink Wireless [Ltd.] ("Dekolink"), manufacturer of this product (the "Product") warrants to the original purchaser ("Purchaser") that the Product is free from defects in materials and workmanship for a term that ends on the earlier of twelve (12) months from the date of activation of the Product or fifteen (15) months from the date of shipment of the Product by Dekolink. The obligations of Dekolink under this warranty shall be limited solely to the repair or exchange or giving credit for, at the option of Dekolink, any Product that may prove defective in accordance with evidence satisfactory to Dekolink. Any repair or replacement of the Product by Dekolink shall not extend the original warranty period. This warranty is exclusive to the original Purchaser and is not assignable.

This warranty applies only upon the condition that the Product has been installed, maintained and operated under conditions of normal use. The provisions of this warranty shall not apply if, in Dekolink's judgment, the Product has been subject to misuse or neglect, damaged in an accident or by act of vandalism, or repaired or altered in any way that adversely affects its performance or reliability.

To obtain warranty service, Purchaser may, upon the prior written authorization of Dekolink or its authorized service representative, return the defective Product to Dekolink's authorized service center. All shipping and insurance charges are the sole responsibility of Purchaser and are not included in this warranty. Dekolink expressly excludes and disclaims all other warranties, including but not limited to any warranties of merchantability or fitness for a particular purpose.

Dekolink shall in no event be liable for any special, indirect, incidental, consequential or punitive damages or for loss, damage, or expense, including loss of use, profits, revenue, or goodwill, directly or indirectly arising from purchaser's use or inability to use the merchandise, or for loss or destruction of other property or from any other cause, even if Dekolink has been advised of the possibility of such damage. Some states do not allow the exclusion or limitation of incidental or consequential damages so these limitations may not apply under certain circumstances.

The liability of Dekolink shall in no event exceed an amount equivalent to the purchase price paid by the purchaser for the defective product.

This warranty shall not be extended, altered or varied except by a written instrument duly signed by Dekolink.