

INSTALLATION AND OPERATING INSTRUCTIONS

The following is a copy of Installation and Operating Instructions of the MW-CBDA-SMR-1W60PS-8 Cellular Bi-Directional Amplifier/Booster.

INSTALLATION

AND

OPERATING INSTRUCTIONS

FOR

MW-CBDA-SMR-1W60PS-8

BI-DIRECTIONAL AMPLIFIER

(COMPACT BDA)

TABLE OF CONTENTS

PARAGRAPH	PAGE NO
BDA OVERVIEW	4
BDA BLOCK DIAGRAM DESCRIPTION	4
BDA BLOCK DIAGRAM DRAWING	5
ELECTRICAL SPECIFICATIONS	6
MECHANICAL SPECIFICATIONS	7
ENVIRONMENTAL CONDITIONS	7
BDA CONNECTIONS	8
PERIODIC MAINTENANCE	8
DIAGNOSTIC GUIDE	9
MECHANICAL OUTLINE	10
RF EXPOSURE WARNING	11

BDA OVERVIEW:

The BDA assembly provides an exceptional repeater/booster performances to extend the coverage area of radio communications in buildings and RF shielded environments.

Features such as high linearity power amplifiers are contributing for the overall improved system linearity performances. The unit is based on a duplexed path configuration, having sharp out of band attenuation for improved isolation between the receiving and transmitting paths.

BDA BLOCK DIAGRAM DESCRIPTION:

The BDA Downlink path receives the RF signals from base station amplifies and transmits them to the subscriber. The BDA Uplink path receives the RF signals from the subscriber amplifies and transmits them to the base station. Two duplexers frequency separate the signals to the proper amplifying path and isolate the two signals.

BDA with AGC (Option A)

The amplifiers in this BDA have an AGC feedback loop. The AGC circuit senses the output power and when it exceeds the preset level of +20 dBm it introduces more attenuation. In this manner the gain of the amplifier is reduced, its output power is limited to +20 dBm and the Intermodulation products are kept low.

The AGC Dynamic range is 30 dB.

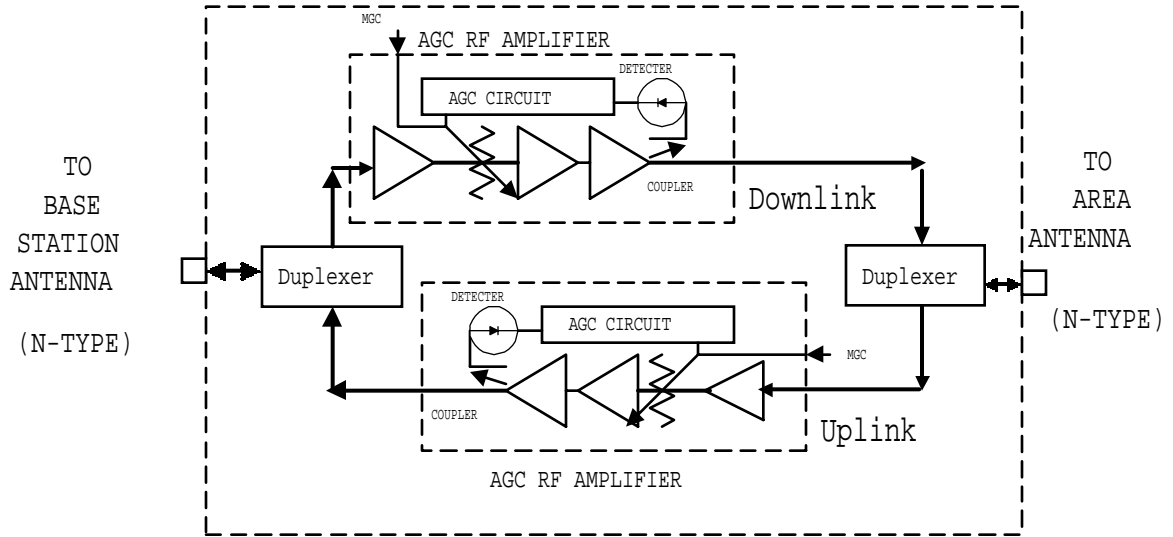

BDA BLOCK DIAGRAM

MW-CBDA-SMR-1W60PS-8

ELECTRICAL SPECIFICATIONS:

Frequency Range	: Up Link : 806 – 824 MHz : Down Link : 851 – 869 MHz
Passband Gain @ min attenuation	: 60 dB minimum
Passband Ripple	: ±1.5 dB typical
Noise Figure @+25°C at max gain	: 6.0 dB max
3rd Order Intercept point	: +45 dBm typical
IMD @2 tone @+20 dBm/carrier	: 50 dBc typical
Isolation between Up/Down Link	: 70 dB min
Impedance Level	: 50 Ohms
VSWR In	: 1.5 : 1 max
Power Supply	: 80 to 240 VAC; 50 to 60 Hz; @500 mA

MECHANICAL SPECIFICATIONS:

Size	: 9.84 x 9.61 x 4.53 inch (250 x 244 x 115 mm)
RF Connectors	: N-type Female
Weight	: 10 Lbs. (5kg.) approx.

ENVIRONMENTAL CONDITIONS:

The unit is designed for indoor applications:

Operating temperature	: - 30°C to + 50°C
Storage temperature	: - 50°C to + 90°C

BDA CONNECTIONS

The BDA AC power is supplied through a standard 3-wire male plug with phase, neutral and safety ground wires. The AC power is only used to supply a high efficiency DC switching power supply. The two amplifiers (Uplink and Downlink) and the Power On lamp use only DC power.

The RF connection is made via two type “N” female connectors. The RF connector labeled “Base” must be connected to the antenna pointing to the base station. The RF connection labeled “Mobile” must be connected to the antenna pointing into the area to be covered by the BDA.

The connections must be made through 50 ohms impedance cables.

The isolation between the base station antenna and the mobile antenna should be at least 12 dB higher than the BDA gain. If the isolation were less than the BDA gain, oscillation would start and would saturate the amplifier. Isolation few dB higher than the BDA gain cannot start oscillations but would causes gain ripple in the band.

PERIODIC MAINTENANCE

The BDA should provide long term, care free operation with no need of any periodic maintenance.

The BDA has no user adjustments or alignments.

The front panel lamp indicates power supply turn on.

DIAGNOSTICS GUIDE

As mentioned before the BDA should provide long term, care free operation with no need of any periodic maintenance. This section will cover possible problems that may show up after installation.

a. Gain Reduction

Possible causes: Bad RF cables and RF connections to antennas, Damaged antennas.

b. Excessive Intermodulation or Spurious

Possible causes:

Amplifier oscillation caused by insufficient isolation. The isolation between two antennas is given by the equation:

$$\text{Isolation} = 92.5 + 20 \text{ Log } (F \times D) - G_t - G_r$$

F is frequency in GHz

D is separation in Km

G_t is the transmit antenna gain (at the direction of the receive antenna).

G_r is the receive antenna gain (at the direction of the transmit antenna).

For example at the SMR frequency the antenna isolation at 100 m separation is about 71 dB for omni antennas (0 dB gain). To increase isolation the antennas should have higher directivity and must be pointed away from each other.

c. Occasional Drop-out of some Channels

Possible causes: One channel with very strong power dominating the RF output of the amplifier.

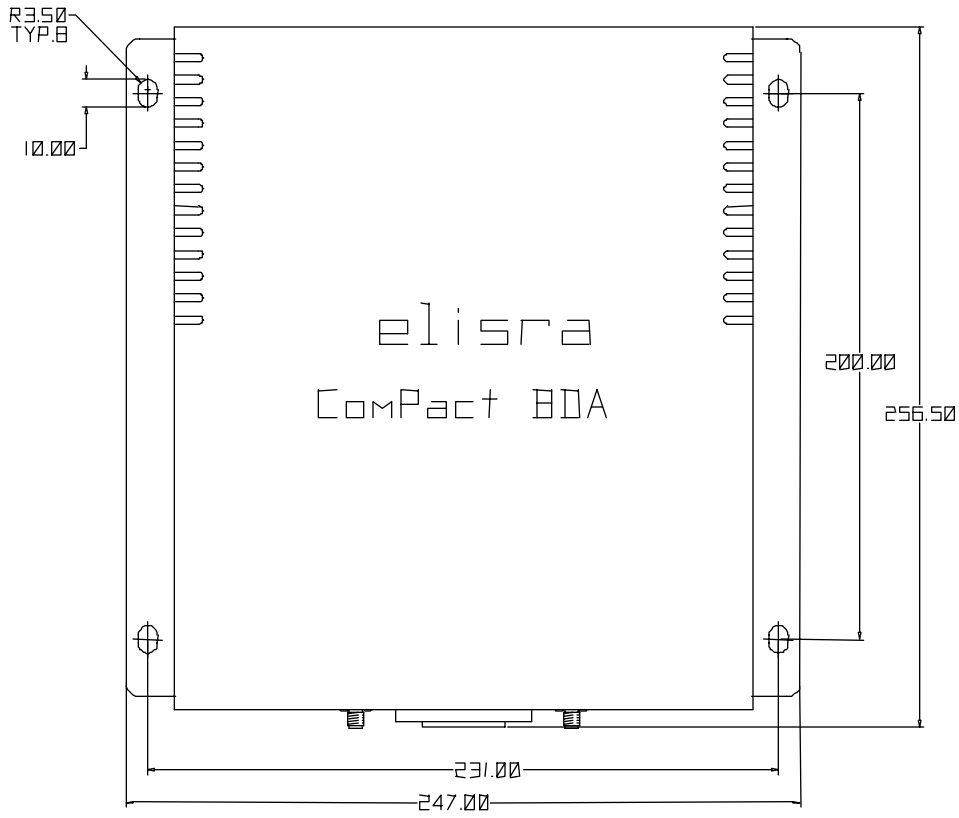
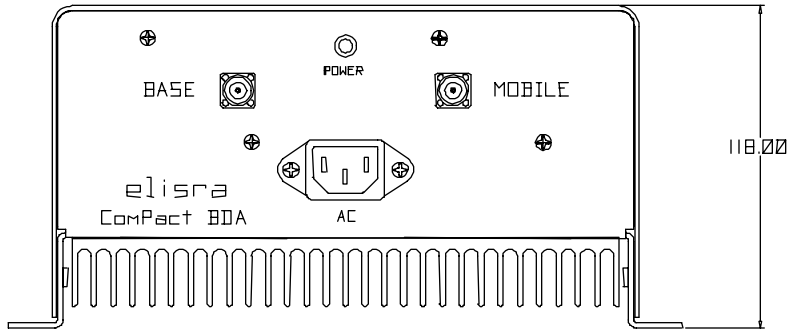

MECHANICAL OUTLINE

RF EXPOSURE WARNING:

In order to satisfy the FCC RF exposure requirements, you must ensure that the installation complies with the following:

One antenna is connected via cable that has 3~10 dB attenuation (depends on the length of the cable) to the CBDA BASE port. This antenna is installed outdoor and has very sharp beam (Yagi type or similar) pointed to the donor (BTS). This type of antenna has about 10 dBi gain. Typical specifications: (model ASPD2996): gain: 8dBd (=10.1dBi), VSWR: better than 1.5:1 , Impedance: 50 ohm, F/B ratio: 18 dB, E-plane Beamwidth: 47deg., H-plane Beamwidth: 58 deg. You must maintain a minimum distance of 0.3m from the outdoor antenna to people within the area.

The second antenna is connected via cable that has 2~6 dB attenuation (depends on the length of the cable) to the CBDA MOBILE port. This type of antenna is omnidirectional (isotropic) with 0 to 2 dBi gain and is installed and distributes indoor (in buildings, tunnels, basements, park lots, shopping centers etc.). This antenna is installed usually on the ceiling. Typical specifications: (Kathrein model No. 741 572): gain: 2dBi, VSWR: better than 2:1 , Impedance: 50 ohm, Polarization: Vertical. You must maintain a minimum distance of 0.1m from the indoor antenna to people within the area.