





ALIENWARE®

ALIENWARE DESKTOP MANUAL

Notes, Cautions, and Warnings

 **NOTE:** A NOTE indicates important information that helps you make better use of your computer.

 **CAUTION:** A CAUTION indicates either potential damage to hardware or loss of data and tells you how to avoid the problem.

 **WARNING:** A WARNING indicates a potential for property damage, personal injury, or death.

This item incorporates copy protection technology that is protected by U.S. patents and other intellectual property rights of Rovi Corporation. Reverse engineering and disassembly are prohibited.

The contents herein are subject to change without notice.

© 2010 Dell Inc. All rights reserved.

Reproduction of these materials in any manner whatsoever without the prior written permission of Dell Inc. is strictly prohibited.

Trademarks used in this manual: Alienware[®], AlienFX[®], and the AlienHead logo are trademarks or registered trademarks of Alienware Corporation; Dell[™] is a trademark of Dell Inc; Microsoft[®], Windows[®], and the Windows start button logo are either trademarks or registered trademarks of Microsoft Corporation in the United States and/or other countries; Intel[®] is a registered trademark and Core[™] and Speedstep[™] are trademarks of Intel Corporation in the U.S. and other countries; Blu-ray Disc[™] is a trademark of the Blu-ray Disc Association; Bluetooth[®] is a registered trademark owned by Bluetooth SIG, Inc. and is used by Dell Inc. under license.

Other trademarks and trade names may be used in this manual to refer to either the entities claiming the marks and names or their products. Dell Inc. disclaims any proprietary interest in trademarks and trade names other than its own.

Regulatory Model: DOIM Regulatory Type: DOIM003

Rev. A00 September 2010

CONTENTS

CHAPTER 1: SETTING UP YOUR DESKTOP	7	CHAPTER 4: INSTALLING ADDITIONAL OR REPLACEMENT COMPONENTS	33
Before Setting Up Your Desktop	8	Before You Begin	34
Connect the Display	9	Removing and Replacing the Side Panel	36
Connect the Keyboard and Mouse	10	Inside View of Your Computer	37
Connect the Network Cable (Optional)	10	Removing and Replacing Memory Module(s)	37
Connect the Power Cable	11	Removing and Replacing Hard Drive(s)	39
Press the Power Button	11	Removing and Replacing Expansion Card(s)	42
Set Up Microsoft Windows	12	CHAPTER 5: TROUBLESHOOTING	45
Connect to the Internet (Optional)	12	Basic Hints and Tips	46
CHAPTER 2: GETTING TO KNOW YOUR DESKTOP	15	Backup and General Maintenance	46
Front View Features	16	Software Diagnostic Tools	47
Back View Features	17	CHAPTER 6: SYSTEM RECOVERY	55
Top View Features	21	AlienRespawn	56
CHAPTER 3: USING YOUR DESKTOP	23	Dell DataSafe Online Backup (Optional)	57
Alienware Command Center	24	CHAPTER 7: SPECIFICATIONS	59
Working With RAID	24	APPENDIX A: GENERAL AND ELECTRICAL SAFETY PRECAUTIONS	63
Optimizing Performance	26	APPENDIX B: CONTACTING ALIENWARE	65
Configuring the BIOS	26		

Dear Valued Alienware Customer,

Welcome to the Alienware family. We are thrilled to include you among the growing number of savvy high-performance computer users.

The Alienware technicians who have crafted your computer have made certain that your high-performance computer is properly optimized and performs to its fullest potential. We build computers with a single unwavering purpose: Build It As If It Were Your Own. The technicians will not rest until your new computer meets or exceeds our very demanding criteria!

We have tested your computer extensively in order to ensure that you enjoy the highest levels of performance. In addition to a standard burn-in period, your computer has been evaluated using real-world tools such as synthetic performance benchmarks.

We invite you to share your experience with your new high-performance computer with us, so do not hesitate to either e-mail or call Alienware with any questions or concerns. The entire staff shares your enthusiasm for new technology and we hope that you enjoy using your new computer as much as Alienware enjoyed building it for you.

Sincerely,

Alienware Staff

אנחנו מודים לך על שיתוף הפעולה

CHAPTER 1: SETTING UP YOUR DESKTOP

Before Setting Up Your Desktop

Congratulations on the purchase of your Alienware Aurora!

Read all safety and setup instructions before connecting your new desktop. Begin by carefully opening the box and removing all components that were shipped to you.

Before setting up your desktop or components, see the included invoice to verify that all items ordered are present and be sure to inspect all items for any physical damage that may have occurred during shipment. Report any missing components to customer service within 5 days of receiving the shipment. Anything reported missing after the first 5 days of receiving a shipment will not be honored. Some of the most common items to check for include:

- Computer
- Microsoft CD-key located at the back of the desktop
- Keyboard (if ordered)
- Mouse (if ordered)
- Multimedia speakers and sub-woofer (if ordered)
- Joystick controllers (if ordered)

You may also need a small flathead and/or a Phillips head screwdriver for connecting peripheral cables to the desktop.

Product Documentation and Media

The documentation that ships with your Alienware desktop is designed to provide answers to many of the questions that may arise as you explore your new desktop's capabilities. You may see the documentation for technical information or general use as required to answer questions in the future, or aid you in finding answers and solutions. The media included with your desktop is referenced in some sections of the documentation and may be needed to complete certain tasks. As always, our technical support staff is available to assist you.

Placing Your Desktop



WARNING: Do not place the desktop near or over a radiator or heating vent. If all or parts of your desktop are placed in a cabinet, ensure that adequate ventilation is provided. Do not place the desktop in a humid location or in any area where the desktop may be exposed to rain or water. Be careful not to spill liquid of any kind on or into the desktop.

When placing your desktop, ensure that:









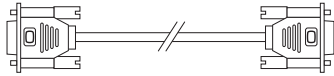
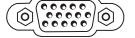
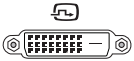
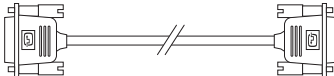

- It is placed on a surface that is both level and stable.
- The power and other cable connectors are not jammed between the desktop and a wall – or any other object.
- Nothing obstructs airflow in front of, behind, or below the desktop.
- The desktop has enough room so that optical drives and other external storage drives can be easily accessed.

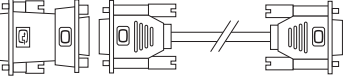
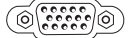
Connect the Display

Connect the display using the connector available on the graphics card in the expansion card slot on your computer.

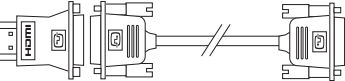
You can purchase the DVI-to-VGA adapter, HDMI-to-DVI adapter, and additional HDMI or DVI cables at www.dell.com.

Use the appropriate cable based on the connectors available on your computer and display. See the following table to identify the connectors on your computer and display.

Connection Type	Computer	Cable	Display
VGA-to-VGA (VGA cable)			
DVI-to-DVI (DVI cable)			
DVI-to-VGA (DVI-to-VGA adapter + VGA cable)			
HDMI-to-HDMI (HDMI cable)			
HDMI-to-DVI (HDMI-to-DVI adapter + DVI cable)			
DisplayPort-to-DisplayPort (DisplayPort cable)			

Connect the Keyboard and Mouse

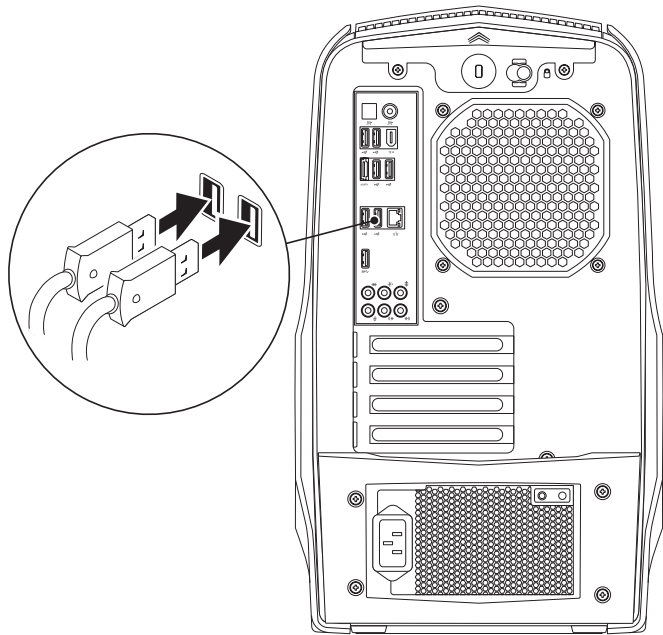

Connect the Network Cable (Optional)

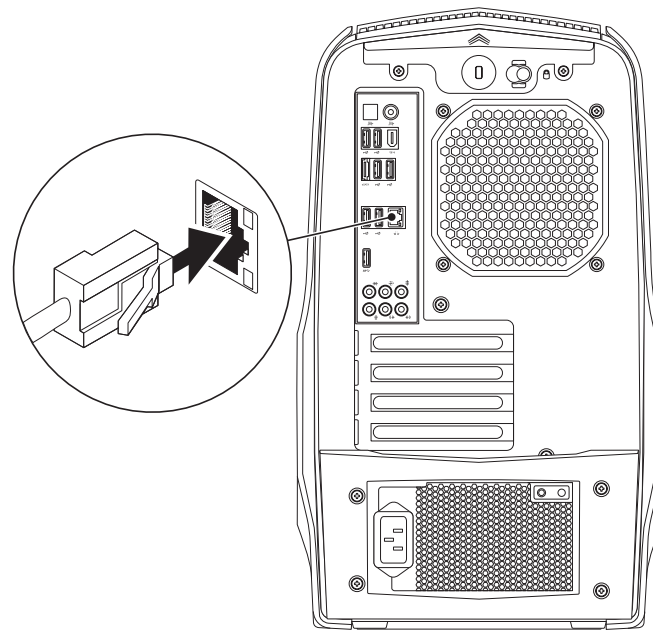

Connect the Power Cable



WARNING: The power connectors and power strips vary among countries. Using an incompatible cable or improperly connecting the cable to a power strip or electrical outlet may cause fire or equipment damage.

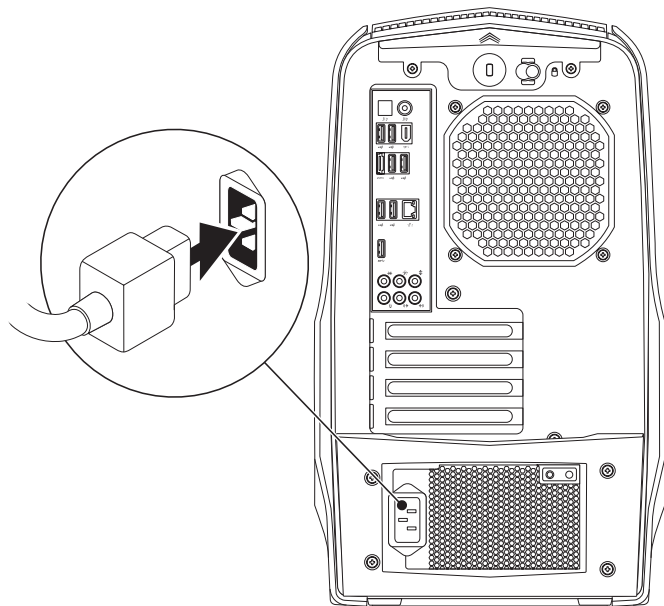

Press the Power Button

Press the power button on the top of the computer.

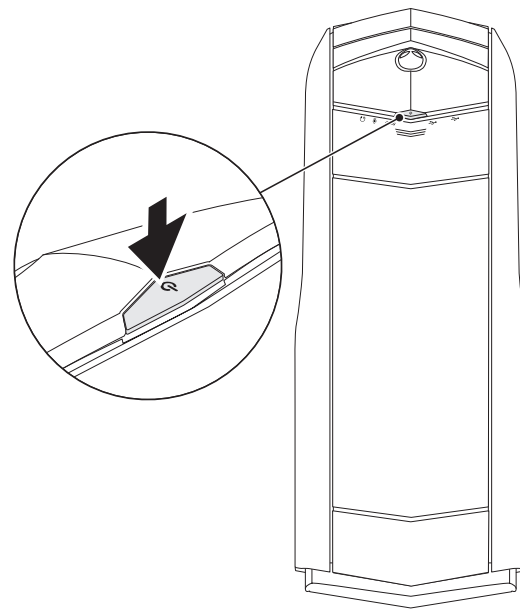

Set Up Microsoft Windows

Your computer is preconfigured with the Microsoft Windows operating system. To set up Windows for the first time, follow the instructions on the screen. These steps are mandatory and may take some time to complete. The Windows setup screens will take you through several procedures including accepting license agreements, setting preferences, and setting up an Internet connection.

 **CAUTION:** Do not interrupt the operating system's setup process. Doing so may render your desktop unusable.

 **NOTE:** For optimal performance of your computer, it is recommended that you download and install the latest BIOS and drivers for your computer available at support.dell.com.

 **NOTE:** For more information on the operating system and features, see support.dell.com/MyNewDell.

Connect to the Internet (Optional)

Setting Up a Wired Connection

- If you are using a dial-up connection, connect the telephone line to the optional external USB modem and to the telephone wall jack before you set up your Internet connection.
- If you are using a DSL or cable/satellite modem connection, contact your ISP or cellular telephone service for setup instructions.

To complete setting up your wired Internet connection, follow the instructions in "Setting Up Your Internet Connection" on page 13.

Setting Up a Wireless Connection



NOTE: To set up your wireless router, see the documentation that shipped with your router.

Before you can use your wireless Internet connection, you need to connect to your wireless router.

To set up your connection to a wireless router:

1. Save and close any open files, and exit any open programs.
2. Click **Start**  **→ Control Panel**.
3. In the search box, type `network`, and then click **Network and Sharing Center** **→ Connect to a network**.
4. Follow the instructions on the screen to complete the setup.

Setting Up Your Internet Connection

ISPs and ISP offerings vary by country. Contact your ISP for offerings available in your country.

If you cannot connect to the Internet but have successfully connected in the past, the Internet Service Provider (ISP) might have a service outage. Contact your ISP to check the service status, or try connecting again later.

Have your ISP information ready. If you do not have an ISP, the **Connect to the Internet** wizard can help you get one.

To set up your Internet connection:

1. Save and close any open files, and exit any open programs.
2. Click **Start**  → **Control Panel**.
3. In the search box, type `network`, and then click **Network and Sharing Center** → **Set up a new connection or network** → **Connect to the Internet**.

The **Connect to the Internet** window appears.



NOTE: If you do not know which type of connection to select, click **Help me choose** or contact your ISP.

4. Follow the instructions on the screen and use the setup information provided by your ISP to complete the setup.



CHAPTER 2: GETTING TO KNOW YOUR DESKTOP

This chapter provides information about your new desktop to familiarize you with its various features, and to get you up and running quickly.

Front View Features

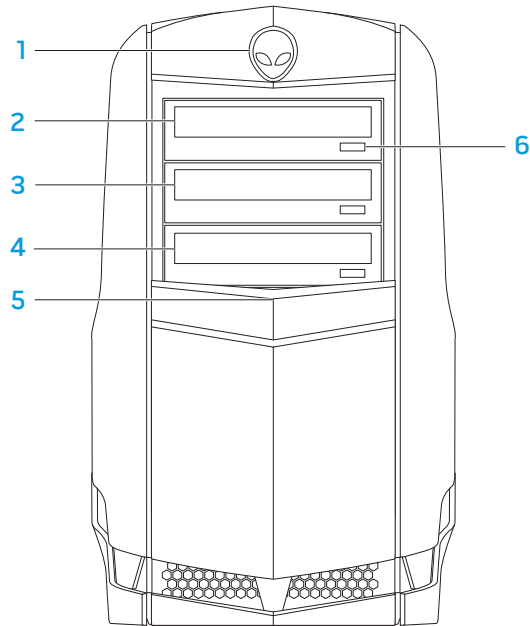

- 1 **Alienhead** — Lowers the drive panel when pressed. The drive panel can also be lowered when the computer is turned off.
- 2 **Optical drive** — Plays or records CDs, DVDs, and Blu-ray Discs.
- 3 **Optical-drive bay** — Can support additional optical drive.
- 4 **Media Card Reader/Optical-drive bay** — Can support an optional Media Card Reader or an additional optical drive.
- 5 **Drive panel** — Covers the optical drive(s) or optical-drive bay(s).
NOTE: The drive panel is shown in the open position.
- 6 **Optical drive eject button** — Ejects the optical-drive tray.

Back View Features

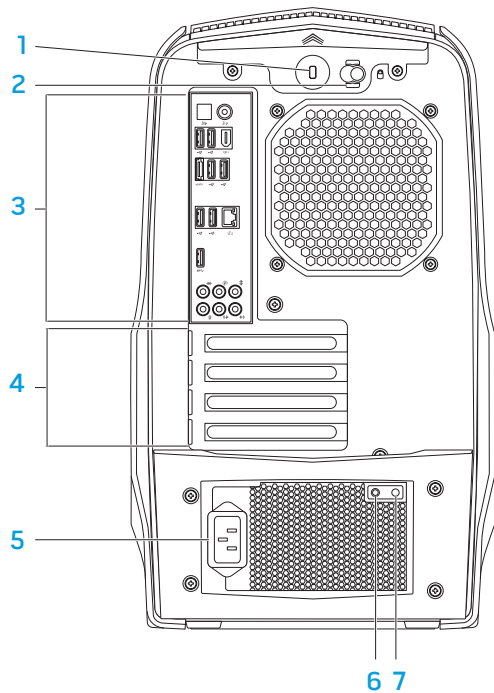

- 1 Security cable slot** — Attaches a commercially available security cable to the computer.
NOTE: Before you buy a security cable, ensure that it fits into the security cable slot on your computer.
- 2 Latch** — Closes or opens the security cable slot and locks or unlocks the release panel. Slide the latch to the right to open the security cable slot and to unlock the release panel.
- 3 Back panel connectors** — Connect USB, audio, and other devices into the appropriate connectors.
For more information, see “Back Panel Connectors” on page 19.
- 4 Expansion card slots** — Access connectors for any installed PCI and PCI Express cards.
- 5 Power connector** — Connects to the power cable.
- 6 Diagnostic light** — Indicates if the power supply is in working condition.
- 7 Diagnostic button** — Turns on the diagnostic light when pressed.





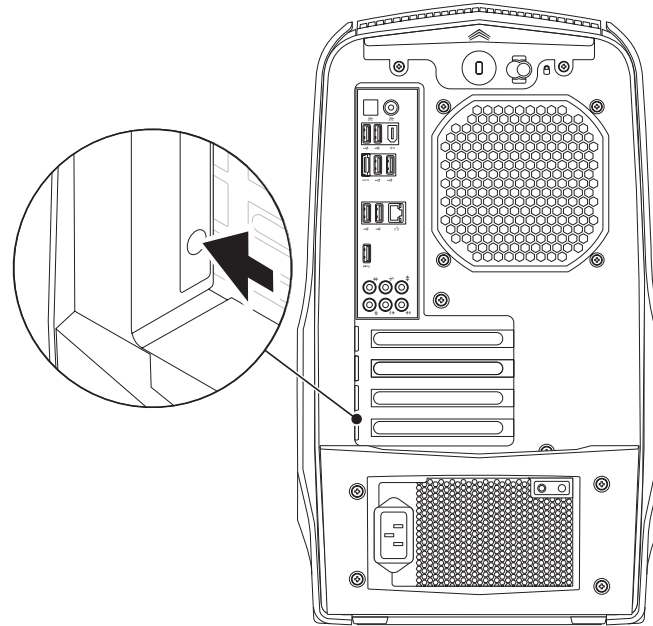

Back Light Button

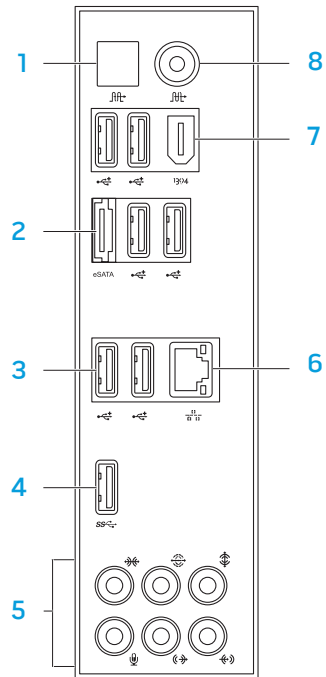
Press the back light button to turn on the light to view the back panel connectors. This light automatically turns off after a few seconds.



Back Panel Connectors







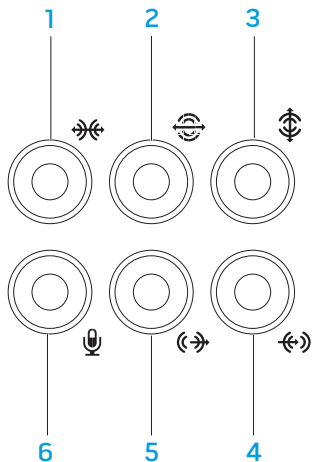

- 1**  **Optical S/PDIF connector** — Connects to amplifiers, speakers, or TVs for digital audio output through optical digital cables. This format carries an audio signal without going through an analog audio conversion process.
- 2**  **eSATA connector** — Connects to eSATA compatible storage devices such as external hard drives or optical drives.
- 3**  **USB 2.0 connectors (6)** — Connect to USB devices, such as a mouse, keyboard, printer, external drive, or MP3 player.
- 4**  **USB 3.0 connector** — Provides faster data transmission between your computer and USB devices.
- 5** **Audio connectors** — Connect to speakers, microphones, and headphones. **NOTE:** For information on audio connectors, see “Connecting External Speakers” on page 20 .
- 6**  **Network connector** — Connects your computer to a network or broadband device.
- 7**  **IEEE 1394 connector** — Connects to high-speed serial multimedia devices such as digital video cameras.
- 8**  **Coaxial S/PDIF connector** — Connects to amplifiers, speakers, or TVs for digital audio output through coaxial digital cables. This format carries an audio signal without going through an analog audio conversion process.

Connecting External Speakers

Your Alienware desktop has five integrated audio out connectors and one audio in connector. The audio out connectors deliver quality sound and support 7.1 surround audio. You can connect the audio input connector from a home stereo or speaker system for a heightened gaming and media experience.

 **NOTE:** On computers with a sound card, use the connector on the card.



- 1  **Side L/R surround connector** — Connects to side L/R surround speakers.
- 2  **Rear L/R surround connector** — Connects to rear L/R surround speakers.
- 3  **Center/subwoofer connector** — Connects to a center speaker or subwoofer.
- 4  **Line-in connector** — Connects to recording or playback devices such as a microphone, cassette player, CD player, or VCR.
- 5  **Front L/R line-out connector** — Connects to front L/R speakers.
- 6  **Microphone connector** — Connects to a microphone or inputs signal for use with audio programs.

Top View Features

Accessing the Top Panel Connectors



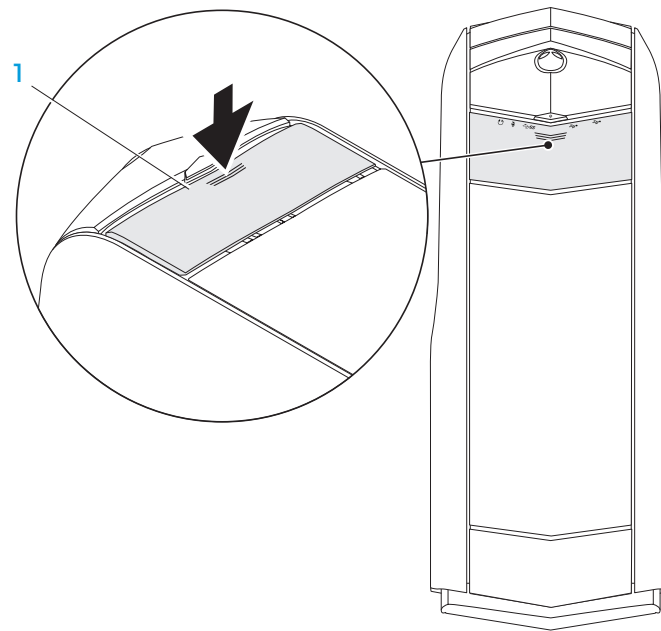

Press the top panel downwards to access the top panel connectors.

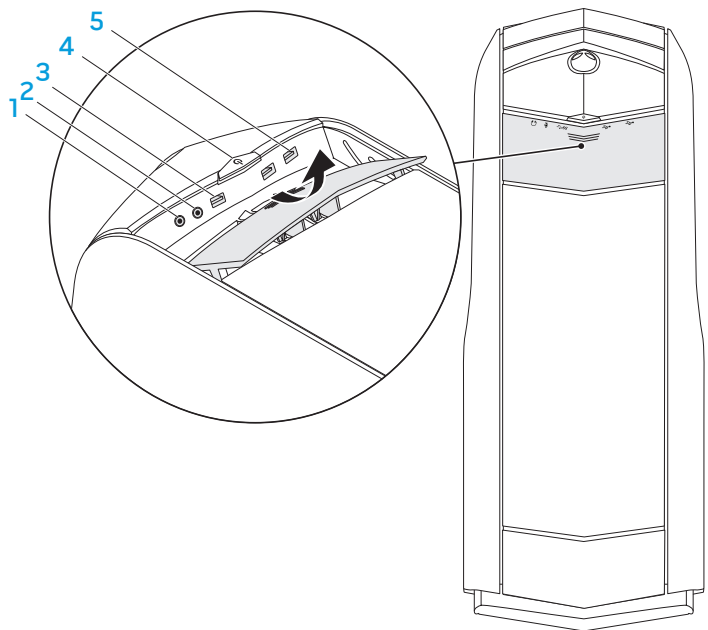

1 Top panel

Top Panel Connectors



-  **Headphone connector** — Connects to headphones.
NOTE: To connect to a powered speaker or sound system, use the audio out connector or one of the S/PDIF connectors at the back of your computer.
-  **Microphone connector** — Connects to a microphone or inputs signal for use with audio programs.
-  **USB 3.0 connector** — Provides faster data transmission between your computer and USB devices.
-  **Power button** — Turns the computer on or off when pressed. The color of the button rim indicates the power status.
 - Off — the computer is either turned off, in hibernate mode, or is not receiving power.
 - Solid white — the computer is on.
 - Blinking white — the computer is in sleep or standby mode.The color indicating the power status can be changed using the AlienFX software. For information on AlienFX, see “AlienFX” on page 24.
-  **USB 2.0 connectors (2)** — Connect to USB devices, such as a mouse, keyboard, printer, external drive, or MP3 player.



CHAPTER 3: USING YOUR DESKTOP

Alienware Command Center

The Alienware Command Center gives you access to Alienware's exclusive software and is a continuously upgradable control panel. As Alienware releases new programs, they download directly into the Command Center allowing you to build a library of system management, optimization, and customization tools.

To access the Command Center, click **Start**  → **All Programs** → **Alienware** → **Command Center** → **Command Center**.

AlienFX

AlienFX allows you to customize the lighting behavior on your computer. You can assign lighting behaviors to events like receiving new e-mail, computer going into the sleep mode, and opening a new application.

AlienFusion

AlienFusion provides access to your Alienware computer's power management controls to help increase energy efficiency.

Thermal Controls

If you have vents present on top of your computer, use thermal controls to control the thermal and venting capabilities of your computer by changing the fan speed and behavior of the vents.

Working With RAID

A Redundant Array of Independent Disks (RAID) is a disk storage configuration that increases performance or data redundancy. There are two basic RAID levels discussed in this section.

- RAID level 0 is recommended for higher performance (faster throughput).
- RAID level 1 is recommended for users who need a high level of data integrity.



NOTE: RAID requires multiple hard drives. The number of hard drives required varies depending on the RAID configuration.



NOTE: For maximum performance of hard drive(s), connect the SATA 3.0 (6Gb/s) compatible hard drive(s) to the SATA 3.0 (6Gb/s) port(s) on the system board.

RAID Level 0



CAUTION: RAID level 0 provides no redundancy. Therefore, a failure of one drive results in the loss of all data. Perform regular backups to protect your data.

RAID level 0 uses data striping to provide a high data access rate. Data striping writes consecutive segments, or stripes, of data sequentially across the physical drive(s) to create a large virtual drive. This allows one of the drives to read data while the other drive is searching for and reading the next block.

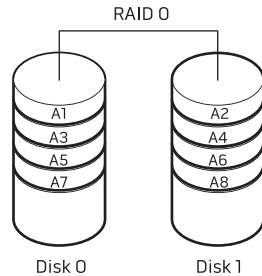

RAID 0 uses the full storage capacities of both drives. For example, two 2 GB hard drives combine to provide 4 GB of hard drive space on which to store data.



NOTE: In a RAID 0 configuration, the size of the configuration is equal to the size of the smallest drive multiplied by the number of drives in the configuration.

RAID Level 1

RAID level 1 uses data mirroring to enhance data integrity. When data is written to the primary drive, the data is also duplicated, or mirrored, on the secondary drive in the configuration. RAID 1 sacrifices high data-access rates for data redundancy.

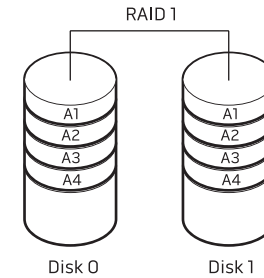

If a drive failure occurs, read and write operations are directed to the remaining drive. A replacement drive can then be rebuilt using the data from the remaining drive.



NOTE: In a RAID 1 configuration, the size of the configuration is equal to the size of the smallest drive in the configuration.

Optimizing Performance

Your computer has been configured to operate optimally across a wide range of applications. Depending on the configuration you purchased, the computer may have been overclocked at the factory to achieve maximum performance in resource intensive applications including gaming and multimedia development.

 **CAUTION: Technical support verifies the full functionality of the computer at the factory configured settings. Alienware does not provide technical support for any hardware or software issues arising from operating the computer beyond the factory configured settings.**

Performance Tuning

Using System Setup

 **CAUTION: It is not recommended to operate the processor or other system components beyond the preset settings in the BIOS. Doing so may cause system instability, reduced component operating life, or permanent component damage.**

For computers with the Intel Core i7 Extreme Edition processor, the BIOS has preset overclocking levels that allow you to easily overclock your computer.

For more information, see “Configuring the BIOS” on page 26.

Configuring the BIOS

System Setup

The System Setup options allow you to:

- Change the system configuration information after you add, change, or remove any hardware in your desktop.
- Set or change a user-selectable option.
- View the amount of memory installed.
- Set the type of hard drive installed.

Before you use System Setup, it is recommended that you write down the current System Setup information for future reference.

 **CAUTION: Do not change the settings in System Setup unless you are an expert computer user. Certain changes can cause your computer to work incorrectly.**

Entering System Setup

1. Turn on (or restart) your desktop.



NOTE: Keyboard failure may result when a key on the keyboard is held down for extended periods of time. To avoid possible keyboard failure, press and release <F2> in even intervals until the System Setup screen appears.

2. While the desktop is booting, press <F2> immediately before the operating system logo appears to access the **BIOS Setup Utility**.
If an error occurs during Power On Self Test (POST), you may also enter the **BIOS Setup Utility** by pressing <F2> when prompted.



NOTE: If you wait too long and the operating system logo appears, continue to wait until you see the Microsoft Windows desktop, then shut down your desktop and try again.

System Setup Screens

The **BIOS Setup Utility** window displays current or changeable configuration information for your desktop.

Key functions appear at the bottom of the **BIOS Setup Utility** window and lists keys and their functions within the active field.

System Setup Options



NOTE: Depending on your computer and installed devices, the items listed in this section may not appear, or may not appear exactly as listed.



NOTE: For the updated system setup information, see the *Service Manual* at support.dell.com/manuals.

Main

BIOS Information

Product Information

Build Date	Displays the BIOS release date.
Product Name	Displays the product name.
BIOS Version	Displays the BIOS version number.
Service Tag	Displays the service tag of the computer.
Asset Tag	Displays the asset tag of the computer.

Memory Information

Total Memory	Displays the total memory of the computer.
Memory Available	Displays the amount of memory available on the computer.
Memory Technology	Displays the type of memory technology used.
Memory Speed	Displays the memory speed.

Main

CPU Information

CPU Type	Displays the processor type.
CPU ID	Displays the processor identification code.
CPU Speed	Displays the processor speed.
Cache L2	Displays the processor L2 cache size.
Cache L3	Displays the processor L3 cache size.

Advanced — Standard CMOS Features

System Date (mm:dd:yy)	Displays current date.
System Time (hh:mm:ss)	Displays the current time.
Device Information	
SATA Port0	Displays the SATA 0 drive integrated in the computer.
SATA Port1	Displays the SATA 1 drive integrated in the computer.
SATA Port2	Displays the SATA 2 drive integrated in the computer.

Advanced — Standard CMOS Features

SATA Port3	Displays the SATA 3 drive integrated in the computer.
SATA Port4	Displays the SATA 4 drive integrated in the computer.
SATA Port5	Displays the SATA 5 drive integrated in the computer.
SATA Port6	Displays the SATA 6 drive integrated in the computer.
SATA Port7	Displays the SATA 7 drive integrated in the computer.
Wait for 'F1' If Errors	If enabled, the system will HALT during boot to display system errors.

Advanced — Advanced BIOS Features

Bootup Num-Lock	Select power-on state for num-lock.
OptionROM Display Screen	Allows you to enable or disable the RAID Option ROM screen during POST.

Advanced — CPU Configuration

Hyper-threading Technology	If disabled only one thread per enabled core is active.
XD Bit Capability	Enable XD Bit Capability to allow the processor to distinguish between the bits of code that can be executed and the ones that cannot be executed.
Intel(R) Speedstep tech	If enabled, the processor clock speed and core voltage are adjusted dynamically based on the processor load.
Intel(R) C-State Tech	If enabled, C-State: Processor idle is set to C2/C3/C4.

Advanced — Integrated Devices

USB Controller	Allows you to enable or disable the integrated USB controller.
HD Audio	Allows you to enable or disable the integrated audio controller.
Onboard IEEE1394 Controller	Allows you to enable or disable the onboard IEEE 1394 controller.
Onboard LAN Controller	Allows you to enable or disable the onboard LAN controller.
LAN Option ROM	Allows you to enable or disable the network controller's boot option.

Advanced — Integrated Devices

Jmicron 362 ATA Controller	Allows you to enable or disable the ATA controller.
ICH SATA Configuration SATA Mode	Allows you to configure the integrated hard drive controller to AHCI or RAID.

Advanced — Power Management Setup

Suspend Mode	Sets the energy-saving mode of the ACPI function.
AC Recovery	Sets what action the computer takes when power is restored.
Auto Power On	Allows the computer to start up at a certain time.

Advanced — Frequency/Voltage Control

Current CPU Frequency	Displays the current processor speed.
Current DRAM Frequency	Displays the current memory speed.
Adjust Cpu Ratio	Allows you to change the processor ratio.
Memory Ratio	Allows you to change the memory ratio.
DRAM Timing Mode	Allows you to change the memory timing mode.

Advanced — Frequency/Voltage Control

Advance DRAM Configuration	Allows you to access the Advance DRAM Configuration submenu.
Overclock Configuration	Allows you to access the Overclock Configuration submenu.
Overvoltage Configuration	Allows you to access the Overvoltage Configuration submenu.
Load Level 1 Defaults	Allows you to load Level 1 default setting. NOTE: This setting may not be available for some processors.
Load Level 2 Defaults	Allows you to load Level 2 default setting. NOTE: This setting may not be available for some processors.

Advanced — ME Subsystem

ME Version	Displays the ME version number.
ME subsystem	Allows you to enable or disable the ME subsystem.
End of Post Message	Allows you to enable or disable the End of Post Message.

Advanced — ME Subsystem

Execute MEBx	Allows you to enable or disable the Execute MEBx.
Integrated Clock Chip Configuration	Allows you to access the Integrated Clock Chip Configuration submenu.

Advanced — ME Subsystem — Integrated Clock Chip Configuration Submenu

ICC OverClocking Lib Version	Displays the ICC OverClocking Lib Version number.
Number of ICC Profiles:	Displays the number of ICC Profiles supported on your computer.
Current ICC Profile Index:	Displays the current ICC Profile Index value.
ICC Enable	Allows you to enable or disable the Integrated Clock Chip.

Advance DRAM Configuration Submenu

Memory-Z	Opens submenu to display the SPD configuration for each memory module.
Command Rate	Displays the Command Rate (editable in Manual Mode).
tCL	Displays the Column Address Strobe Latency (editable in Manual Mode).

Advance DRAM Configuration Submenu

tRCD	Displays timing of RAS to CAS delay (editable in Manual Mode).
tRP	Displays timing of RAS Precharge (editable in Manual Mode).
tRAS	Displays timing of Row Address Strobe (editable in Manual Mode).
tRFC	Displays timing of Refresh to Archive/Refresh cycle time (editable in Manual Mode).
tWR	Displays timing of Write Recover (editable in Manual Mode).
tWTR	Displays Write to Read Delay (editable in Manual Mode).
tRRD	Displays RAS to RAS delay (editable in Manual Mode).
tRTP	Displays Read to Precharge Command Delay (editable in Manual Mode).
tFAW	Displays the Four Activate Window (editable in Manual Mode).
tWCL	Displays the Write CAS Latency (editable in Manual Mode).
tCKE	Displays the Minimum CKE High and Low Pulse Width (editable in Manual Mode).

Overclock Configuration Submenu

Turbo Mode	If enabled, allows processor to run at faster frequencies than marked.
Long duration power limit	Allows you to change the long duration power limit.
Long duration maintained	Allows you to change the long duration time limit.
Short duration power limit	Allows you to change the short duration power limit.
1-Core Ratio Limit	Allows you to change the ratio limit of the processor's first core.
2-Core Ratio Limit	Allows you to change the ratio limit of the processor's second core.
3-Core Ratio Limit	Allows you to change the ratio limit of the processor's third core.
4-Core Ratio Limit	Allows you to change the ratio limit of the processor's fourth core.
VID Override for Max Turbo Ratio	Allows you to change the VID override for max turbo ration value.

Overvoltage Configuration Submenu

DDR3 Memory Voltage	Adjusts the DDR3 Memory Voltage.
Dynamic CPU VCore Offset	Allows you to change the Processor Core Voltage Offset value.
Adjust DDR_VREF_DQ_A	Adjusts the DDR3 Data VREF – Channel A.
Adjust DDR_VREF_DQ_B	Adjusts the DDR3 Data VREF – Channel B.
Adjust DDR_VREF_CA_A	Adjusts the DDR3 Address VREF – Channel A.
Adjust DDR_VREF_CA_B	Adjusts the DDR3 Address VREF – Channel B.

Security

Supervisor Password:	Allows you to change the supervisor password.
User Password:	Allows you to change the user password. You cannot use the user password to enter the BIOS setup, during POST.
Set Supervisor Password	Allows you to set a supervisor password.

Boot

Set Boot Priority	
1st Boot Device	Displays the first boot device.
2nd Boot Device	Displays the second boot device.
3rd Boot Device	Displays the third boot device.
4th Boot Device	Displays the fourth boot device.
5th Boot Device	Displays the fifth boot device.
6th Boot Device	Displays the sixth boot device.
7th Boot Device	Displays the seventh boot device.
Hard Disk Drive BBS Priorities	Sets the hard drive boot priority. The items displayed are dynamically updated according to the hard drives detected.
CD/DVD ROM Drive BBS Priorities	Sets the CD/DVD drive boot priority.

Exit

Provides options to Save Changes and Reset, Discard Changes and Reset, Restore Defaults, and Reset System with ME disable Mode.

~XVCXVI ©: XCDXVEEACI: VU"XAXXZCVZ
XI IXCXY-VIICX -ZTCZCICX

CHAPTER 4: INSTALLING ADDITIONAL OR REPLACEMENT COMPONENTS

This chapter provides guidelines and instructions for increasing the processing power and storage capacity, by upgrading equipment. You can purchase components for your desktop at www.dell.com or www.alienware.com.



NOTE: See the *Service Manual* at support.dell.com/manuals for installation instructions of all serviceable components. Parts purchased from Dell and Alienware ship with specific replacement instructions.

Before You Begin

This section provides procedures for removing and installing the components in your desktop. Unless otherwise noted, each procedure assumes that the following conditions exist:

- You have performed the steps in “Turning Off Your Desktop” and “Before Working Inside Your Desktop” in this section.
- You have read the safety information that shipped with your desktop.
- A component can be replaced or—if purchased separately—installed by performing the removal procedure in reverse order.

The procedures in this section may require the following tools:

- Small flat-blade screwdriver
- Phillips screwdriver
- BIOS executable update program available at support.dell.com

Turning Off Your Desktop



CAUTION: To avoid losing data, save and close all open files and exit all open programs before you turn off your desktop.

1. Save and close all open files and exit all open programs.
2. Click **Start**  → **Shut Down**.
The desktop turns off after the operating system shutdown process finishes.
3. Ensure that the desktop and any attached devices are turned off. If your desktop and attached devices do not automatically turn off when you shut down your operating system, press and hold the power button for at least 8 to 10 seconds until the desktop turns off.

Before Working Inside Your Desktop

Use the following safety guidelines to help protect your desktop from potential damage and to help to ensure your own personal safety.



WARNING: Before working inside your desktop, read the safety information that shipped with your computer. For additional safety best practices information, see www.dell.com/regulatory_compliance.



CAUTION: Handle components and cards with care. Do not touch the components or contacts on a card. Hold a card by its edges. Hold a component such as a processor by its edges, not by its pins.



CAUTION: Only a certified service technician should perform repairs on your desktop. Damage due to servicing that is not authorized by Dell is not covered by your warranty.



CAUTION: To avoid electrostatic discharge, ground yourself by using a wrist grounding strap or by periodically touching an unpainted metal surface (such as a connector on the back of the computer).



CAUTION: When you disconnect a cable, pull on its connector or on its pull-tab, not on the cable itself. Some cables have connectors with locking tabs; if you are disconnecting this type of cable, press in on the locking tabs before you disconnect the cable. As you pull connectors apart, keep them evenly aligned to avoid bending any connector pins. Also, before you connect a cable, ensure that both connectors are correctly oriented and aligned.

To avoid damaging the desktop, perform the following steps before you begin working inside the desktop.

1. Ensure that the work surface is flat and clean to prevent the side panel from being scratched.
2. Turn off your desktop (see “Turning Off Your Desktop” on page 34).



CAUTION: To disconnect a network cable, first unplug the cable from your desktop and then unplug the cable from the network device.

3. Disconnect all telephone or network cables from the desktop.
4. Disconnect your desktop and all attached devices from their electrical outlets.
5. Press the power button to ground the system board.

Removing and Replacing the Side Panel

 **CAUTION:** Before removing the side panel, disconnect the power cable from your desktop.

To remove the side panel:

1. Follow the instructions in “Before You Begin” on page 34.

 **NOTE:** Ensure that you remove the security cable from the security cable slot (if applicable).

2. Slide the latch to the right to unlock the release panel.
3. Lift the release panel to open the side panel.
4. Place the side panel in a secure location.

 **NOTE:** Theater lighting turns on automatically when the side panel is removed. Theater lighting is powered by internal batteries.

To replace the side panel, push the side panel against the side of the computer until it locks into place.

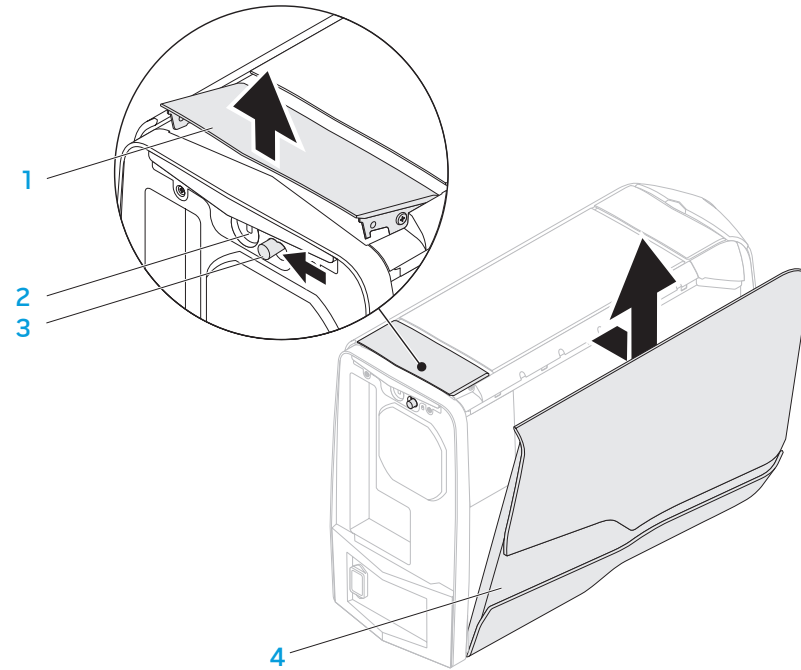

1 release panel
3 latch

2 security cable slot
4 side panel

Inside View of Your Computer

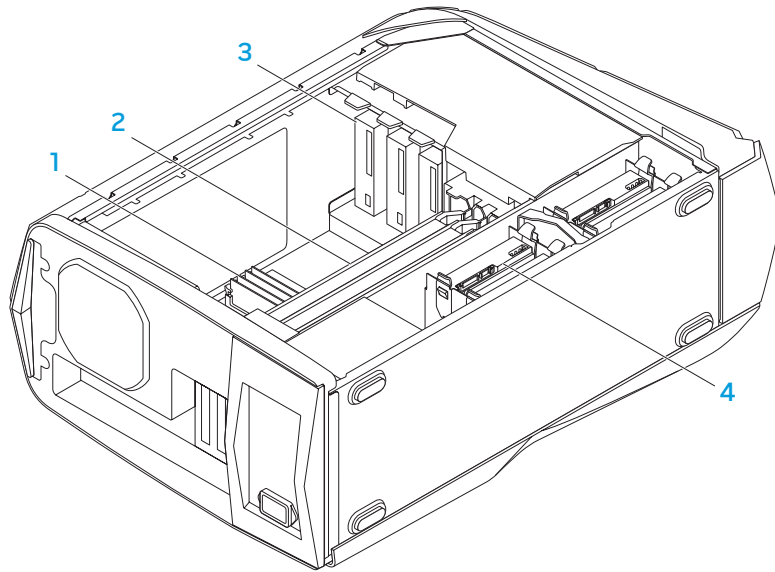



- | | | | |
|---|--------------------|---|--------------------|
| 1 | memory module(s) | 2 | graphics cards (2) |
| 3 | optical drives (3) | 4 | hard drives (4) |

Removing and Replacing Memory Module(s)

To remove the memory module(s):

1. Follow the instructions in "Before You Begin" on page 34.
2. Remove the side panel (see "Removing and Replacing the Side Panel" on page 36).
3. Locate the memory module connectors on the system board (see "Inside View of Your Computer" on page 37).

 **CAUTION:** The memory module(s) may become very hot during normal operation. Allow the memory module(s) to cool before touching them.

 **NOTE:** For better access to memory module(s), remove the graphics card if the card is full length.

4. Spread apart the securing clips at both ends of the memory module connector.
5. Lift the memory module off the memory module connector. If the memory module is difficult to remove, gently ease the memory module back and forth to remove it from the memory module connector.

To replace memory module(s):

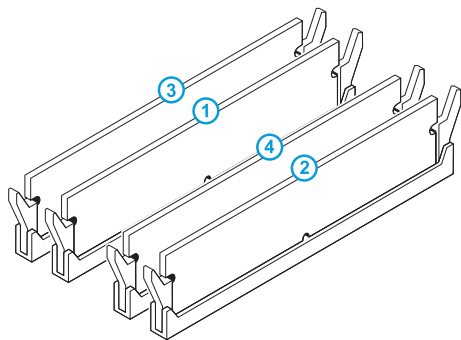

Recommended memory configuration:

Type	Slots
1333 MHz, 1600 MHz, and 1866 MHz	Slots 1 and 2 or slots 1 — 4

1. Follow the instructions in “Before You Begin” on page 34.
2. Align the notch on the bottom of the memory module with the tab on the memory module connector.

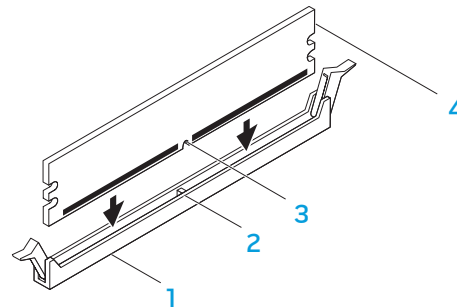

- | | |
|---------------------------|-----------------|
| 1 memory module connector | 2 tab |
| 3 notch | 4 memory module |



CAUTION: To avoid damage to the memory module, press the memory module straight down into the memory module connector while you apply equal force to each end of the memory module.

3. Insert the memory module into the memory module connector until the memory module snaps into position.

If you insert the memory module correctly, the securing clips snap into the cutouts at each end of the memory module.



NOTE: If the memory module is not installed properly, the computer may not boot.

4. Replace the side panel (see “Removing and Replacing the Side Panel” on page 36).
5. Connect the power cable, and all the external peripherals to the computer.
6. Turn on the computer.

As the computer boots, it detects the additional memory and automatically updates the system configuration information. To confirm the amount of memory installed in the computer:

Click **Start**  → **Control Panel** → **System and Security** → **System**.

Removing and Replacing Hard Drive(s)



NOTE: For maximum performance of hard drive(s), connect the SATA 3.0 (6Gb/s) compatible hard drive(s) to the SATA 3.0 (6Gb/s) port(s) on the system board.

To remove the hard drive(s):

1. Follow the instructions in “Before You Begin” on page 34.
2. Remove the side panel (see “Removing and Replacing the Side Panel” on page 36).
3. Disconnect the power and data cable from the hard drive (if applicable).

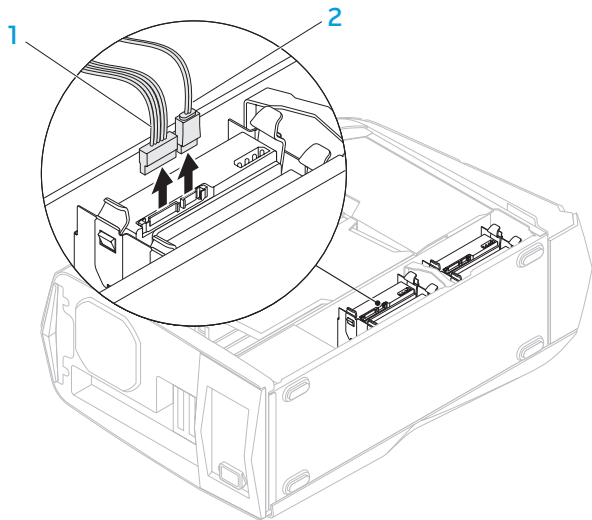

1 power cable

2 data cable

4. Press the release tabs together and slide the hard drive out of the hard drive cage.

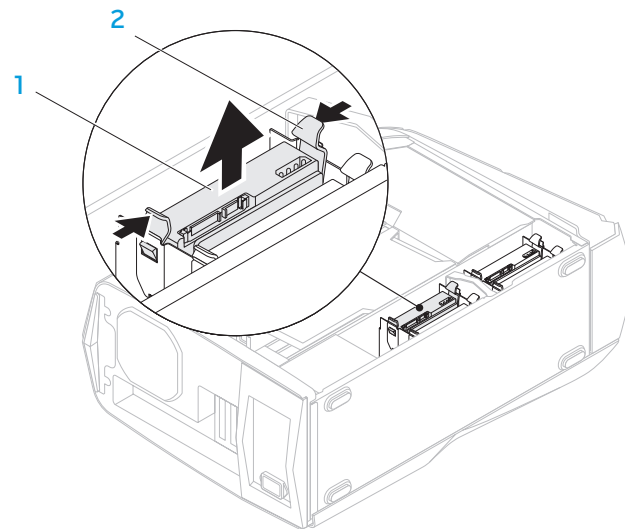

1 hard drive

2 release tabs (2)

5. Remove the hard drive out of the hard-drive bracket (if applicable).

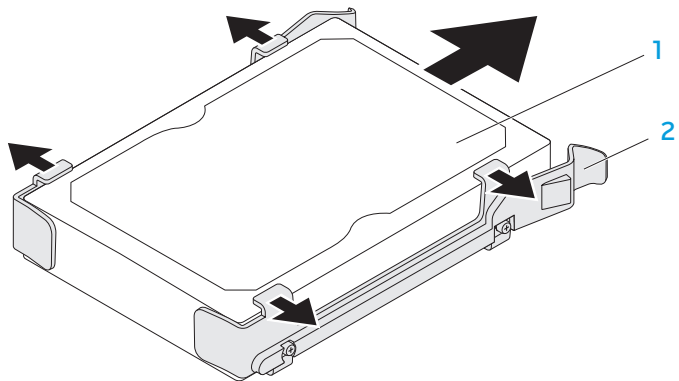

1 hard drive

2 hard-drive bracket

To replace a hard drive:

1. Follow the instructions in "Before You Begin" on page 34.
2. See the documentation that shipped with your new hard drive to verify that it is configured for your computer.
3. Snap the new hard-drive bracket on to the new hard drive (if applicable).
4. Slide the new hard drive into the hard-drive cage until the release tabs snap into place.
5. Connect the power and data cables (if applicable).
6. Replace the side panel (see "Removing and Replacing the Side Panel" on page 36).
7. Reconnect the power cable, and all the external peripherals to the computer.
8. Turn on the computer.

Removing and Replacing Expansion Card(s)

To remove a card:

1. Follow the instructions in “Before You Begin” on page 34.
2. Remove the side panel (see “Removing and Replacing the Side Panel” on page 36).
3. Press the shroud button and rotate the shroud away from the computer.

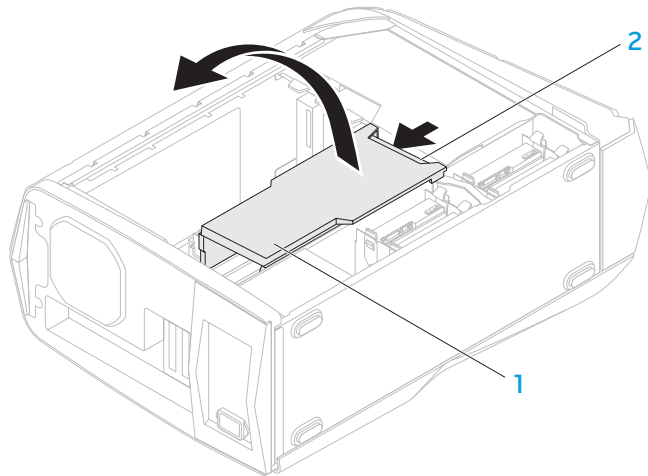

1 shroud

2 shroud button

4. Locate the expansion card on the system board (see “Inside View of Your Computer” on page 37).
5. Disconnect any cables connected to the card (if applicable).
6. Remove the screw that secures the card to the chassis.
7. Remove the card.
 - For a PCI Express x1 card, grasp the card by its top corners, and ease it out of its connector.
 - For a PCI Express x16 card, press the securing tab on the card connector as you grasp the card by its top corners, and then ease the card out of the connector.

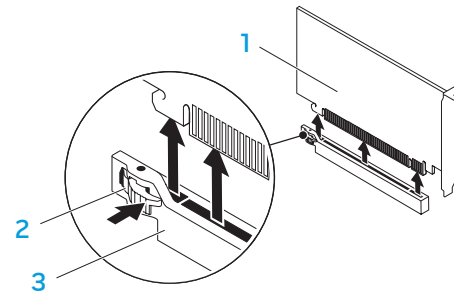

1 PCI Express x16 card

2 securing tab

3 connector



NOTE: If you are not replacing a card, install a filler bracket in the empty card-slot opening.

To replace a card:

1. Follow the instructions in “Before You Begin” on page 34.
2. Remove the filler bracket to create a card-slot opening (if applicable).
3. Align the card with the slot on the connector.
4. Place the card in the connector and press down firmly. Ensure that the card is firmly seated in the slot.

If you are installing a PCI Express Card into the x16 connector, press the securing tab and place the card in the connector.

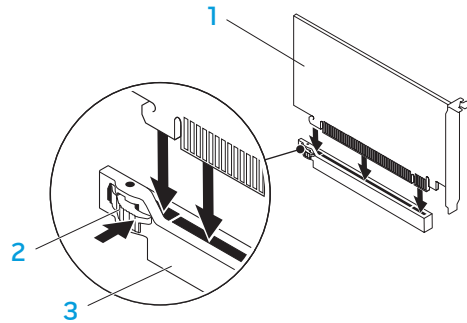

1 PCI Express x16 card

2 securing tab

3 connector

5. Connect any cables that should be attached to the card (if applicable). For information about the card's cable connections, see the documentation that shipped with the card.
6. Replace the screw that secures the card to the chassis.
7. Push the shroud to snap it into place.
8. Replace the side panel (see “Removing and Replacing the Side Panel” on page 36).
9. Reconnect the power cable, and all the external peripherals to the computer.
10. Turn on the computer.

ህዝብ ለግብይት

CHAPTER 5: TROUBLESHOOTING

Basic Hints and Tips

- The computer does not turn on: Is your computer securely plugged into a working electrical outlet? If plugged into a power strip, ensure that the strip is working.
- Connections: Check all the cables to ensure that there are no loose connections anywhere.
- Power Savings: Ensure that your computer is not in hibernate or standby mode by pressing the power button for less than 4 seconds. The power status light will fade from blinking white to off while in standby mode; in hibernate mode it will be off.

Backup and General Maintenance

- Always backup your important data on a regular basis and keep copies of your operating system and software safe. Do not forget to note the serial numbers if you are storing them outside of their original cases — for example in a CD wallet.
- Run maintenance programs as often as you can. You may schedule these programs to run at times when you are not using your computer. You can use those provided with your operating system, or buy more powerful, dedicated programs to do so.
- Write down your passwords and keep them safe (away from your computer). This is especially important if you choose to password-protect your computer's BIOS and operating system.
- Document vital settings such as network, dialup, mail and Internet settings.

When troubleshooting your computer, remember the following safety guidelines:

- Before touching any of the computer's internal components, touch an unpainted portion of the chassis. Doing so will safely discharge any static electricity, which could damage your computer.
- Turn off your computer and any connected peripherals.
- Disconnect any peripherals from your computer.

Things to check before troubleshooting:

- Ensure that the power cable is properly connected to your computer and a power outlet. Ensure that the power outlet is working.
- Ensure that the UPS or power strip is turned on (if applicable).
- If your peripheral devices (for example keyboard, mouse, printer, and so on) are not working, ensure that all connections are secure.
- If any computer components were added or removed before the problem began, check to see if you performed the removal and installation procedure properly.
- If an error message appears on the screen, write down the exact error message prior to calling Alienware Technical Support to aid in diagnosing and resolving your issue.
- If an error occurs in a specific program, see the program's documentation.

Software Diagnostic Tools

Pre-Boot System Assessment (PSA)

The computer runs the Pre-boot System Assessment (PSA), a series of initial tests for the system board, keyboard, display, memory, hard drive, and so on.

To invoke PSA:

1. Turn on (or restart) your desktop.
2. When the Alienware logo appears, press <F12> immediately to access the **Boot Menu**.



NOTE: If you wait too long and the operating system logo appears, continue to wait until you see the Microsoft Windows desktop; then, shut down your computer and try again.

3. Select **Diagnostics** from the menu and press <Enter>.
4. During the assessment, answer any questions that appear on the screen.
 - If a failure is detected, the computer stops and beeps. To stop the assessment and restart the computer, press <n>; to continue to the next test, press <y>; to retest the component that failed, press <r>.
 - If failures are detected during the Pre-boot System Assessment, write down the error code(s) and contact Alienware (see "CONTACTING ALIENWARE" on page 65).

If the PSA completes successfully, the following message appears on your screen.

```
"Do you want to run the remaining memory tests? This will
take about 30 minutes or more. Do you want to continue?
(Recommended)."
```

Press <y> to continue if you are experiencing memory issue, otherwise press <n> to finish PSA testing.

When you press <n>, the following message appears on the screen.

```
"Booting Dell Diagnostic Utility Partition. Press any key to
continue."
```

5. Select **Exit** to reboot your computer.

Alienware Diagnostics

If you experience a problem with your Alienware desktop, run the Alienware Diagnostics before you contact Alienware for technical assistance. It is recommended that you print these procedures before you begin.



NOTE: Back up all data before initiating a system recovery.



NOTE: The *Resource DVD* contains drivers for your computer. You can also download the latest drivers and software for your computer from support.dell.com.

Review your desktop's configuration information, and ensure that the device that you want to test appears in the system setup program and is active. Start the Alienware Diagnostics from the *Resource DVD*.

Starting Alienware Diagnostics From the Resource DVD

1. Insert the *Resource DVD*.
2. Shut down and restart the desktop.
When the Alienware logo appears, press <F12> immediately.



NOTE: If you wait too long and the operating system logo appears, continue to wait until you see the Microsoft Windows desktop; then, shut down your computer and try again.



NOTE: The next steps change the boot sequence for one time only. On the next start-up, the computer boots according to the devices specified in the system setup program.

3. When the boot device list appears, highlight **CD/DVD/CD-RW** and press <Enter>.
4. Select **Boot from CD-ROM** from the menu that appears and press <Enter>.
5. Select **Alienware Diagnostics** from the numbered list. If multiple versions are listed, select the version appropriate for your computer.
6. When the Alienware Diagnostics **Main Menu** appears, select the test you want to run.



NOTE: Write down any error codes and problem descriptions exactly as they appear and follow the instructions on the screen.

7. After all tests have completed, close the test window to return to the Alienware Diagnostics **Main Menu**.
8. Remove your *Resource DVD*, then close the **Main Menu** window to exit the Alienware Diagnostics and restart the computer.

Computer Problems

The computer fails the POST

The Power On Self Test (POST) ensures that all hardware is working properly before starting the remainder of the boot process. If the computer passes the POST, the computer continues to start normally. However, if the computer fails the POST, the computer emits a series of beeps during start-up. The following repetitive beep codes help you troubleshoot problems with your computer. For assistance, contact Alienware (see “CONTACTING ALIENWARE” on page 65).



NOTE: To replace parts, see the *Service Manual* at support.dell.com/manuals.

Beep Code	Possible Problem
One	Possible motherboard failure — BIOS ROM checksum failure
Two	No RAM detected NOTE: If you installed or replaced the memory module, ensure that the memory module is seated properly.
Three	Possible motherboard failure — Chipset error
Four	RAM read/write failure
Five	Real Time Clock failure
Six	Video card or chip failure
Seven	Processor failure

The computer stops responding or a solid blue screen appears

 **CAUTION:** You might lose data if you are unable to perform an operating system shutdown.

If you are unable to get a response by pressing a key on your keyboard or moving your mouse, press and hold the power button for at least 6 seconds until the computer turns off, then restart your computer.

A program stops responding or crashes repeatedly

End the program:

1. Press <Ctrl><Shift><Esc> simultaneously.
2. Click the **Applications** tab and select the program that is no longer responding.
3. Click **End Task**.

Check the software documentation.

If necessary, uninstall and then reinstall the program.

A program is designed for an earlier version of Microsoft Windows

Run the Program Compatibility Wizard:

The **Program Compatibility Wizard** configures a program so that it runs in an environment similar to non-Windows operating system environment.

1. Click **Start**  → **Control Panel** → **Programs** → **Run programs made for previous versions of Windows**.
2. In the welcome screen, click **Next**.
Follow the instructions on the screen.

Other software problems

Back up your files immediately

Use a virus-scanning program to check the hard drive, or CDs

Save and close any open files or programs and shut down your computer through the Start menu.

Scan the computer for spyware:

If you are experiencing slow computer performance, you frequently receive pop-up advertisements, or you are having problems connecting to the Internet, your computer might be infected with spyware. Use an anti-virus program that includes anti-spyware protection (your program may require an upgrade) to scan the computer and remove spyware.

Check the software documentation or contact the software manufacturer for troubleshooting information:

- Ensure that the program is compatible with the operating system installed on your computer.
- Ensure that your computer meets the minimum hardware requirements needed to run the software. For more information see the software documentation.
- Ensure that the program is installed and configured properly.
- Verify that the device drivers do not conflict with the program.
- If necessary, uninstall and then reinstall the program.

Run the PSA Diagnostics:

If all the tests run successfully, the error condition is related to a software problem.

Hard Drive Problems



NOTE: For maximum performance of hard drive(s), connect the SATA 3.0 (6Gb/s) compatible hard drive(s) to the SATA 3.0 (6Gb/s) port(s) on the system board.

Allow the computer to cool before turning it on

A hot hard drive may prevent the operating system from starting. Try allowing the computer to return to room temperature before turning it on.

Run Check Disk

1. Click **Start**  → **Computer**.
2. Right-click **Local Disk C:**.
3. Click **Properties** → **Tools** → **Check Now**.
If the **User Account Control** window appears, click **Continue**.
4. Follow the instructions on the screen.

Memory

Memory errors detected on start up

- Check memory modules for correct seating and orientation. Reseat the memory modules if applicable (for more information, see “Removing and Replacing Memory Module(s)” on page 37).
- Computers using a dual-channel memory configuration require that memory modules be installed in pairs. If you require assistance, contact Alienware Technical Support (see “CONTACTING ALIENWARE” on page 65).

Display

If the display is blank

- The computer maybe in a power saving mode. Press a key on the keyboard or press the power button to resume normal operation.
- Test the electrical outlet. Ensure that the electrical outlet is working by testing it with another device, such as a lamp.

Power

When you press the power button, the computer does not turn on

- If the computer is connected into a surge protector or UPS, ensure that the surge protector or UPS is securely connected to an electrical outlet, is switched on and is working correctly.
- Ensure that the electrical outlet is working properly by testing another device such as a radio or lamp that is known to be working. If the electrical outlet is not working, contact an electrician or your power company for further assistance.
- Ensure all devices on the computer are properly connected to your computer and that the computer is properly connected to the surge protector or UPS.
- When the computer is connected into an electric outlet, press the diagnostic button and observe the diagnostic light (to locate the diagnostic button and diagnostic light, see “Back View Features” on page 17) .
 - If the diagnostic light turns ON, the power supply is functioning as designed.
 - If the diagnostic light does not turn ON, there may be a problem with the computer.

For further assistance, contact Alienware support (see “CONTACTING ALIENWARE” on page 65).

USB Devices



NOTE: For maximum performance of USB device(s), connect USB 3.0 compatible USB device(s) to the USB 3.0 port(s) on your computer.

USB keyboard or mouse is not responding when connected to USB 3.0 connector

Ensure that the USB keyboard and mouse are properly connected to your computer and then restart your computer.



CHAPTER 6: SYSTEM RECOVERY

Your computer has the following system recovery options:

- **Operating System Reinstallation DVD** — Contains operating system installation media.
- **AlienRespawn** — Your computer is pre-installed with AlienRespawn (see “AlienRespawn” on page 56).
- **Dell DataSafe Online** — Dell DataSafe Online is an online data backup service (see “Dell DataSafe Online Backup” on page 57).
- **System Drivers** — You can download the latest drivers for your computer from support.dell.com.
- **Resource DVD** — Contains drivers for your computer. You can also download the latest system drivers from support.dell.com.
- **System Applications** — Some of the software that is pre-installed on your computer does not include a backup CD/DVD. This software is available at [My Dell Downloads \(DownloadStore.dell.com/media\)](http://MyDellDownloads.DownloadStore.dell.com/media).



NOTE: My Dell Downloads may not be available in all regions.

AlienRespawn

 **CAUTION:** Using AlienRespawn permanently removes any programs or drivers installed after you received your computer. Create backup media of applications you need to install on your computer before using AlienRespawn. Use AlienRespawn only if System Restore did not resolve your operating system problem.

 **CAUTION:** Although AlienRespawn is designed to preserve the data files on your computer, it is recommended that you backup your data files before using AlienRespawn.

You can use AlienRespawn to restore your hard drive to the operating state it was in when you purchased your computer, while preserving the data files.

AlienRespawn allows you to backup and restore your computer to an earlier operating state.

AlienRespawn Basic

To restore the factory image while preserving the data files:

1. Turn off your computer.
2. Disconnect all the devices connected to the computer (such as USB drive, printer, and so on) and remove any recently added internal hardware.



NOTE: Do not disconnect the monitor, keyboard, mouse, and the power cable.

3. Turn on your computer.
4. When the Alienware logo appears, press <F8> several times to access the **Advanced Boot Options** window.



NOTE: If you wait too long and the operating system logo appears, continue to wait until you see the Microsoft Windows desktop; then, shut down your computer and try again.

5. Select **Repair Your Computer**.
6. Select **AlienRespawn and Emergency Backup** from the **System Recovery Options** menu and follow the instructions on the screen.



NOTE: The restoration process may take an hour or more depending on the size of the data to be restored.



NOTE: For more information on AlienRespawn, see knowledge base article 353560 at support.dell.com.

Upgrading to AlienRespawn Professional

AlienRespawn provides additional features that allow you to:

- Backup and restore your computer based on file types
- Backup files to a local storage device
- Schedule automated backups

To upgrade to AlienRespawn Professional:

1. Double-click the AlienRespawn icon  in the notification area of your desktop.
2. Click **Upgrade Now!**
3. Follow the instructions on the screen.

Dell DataSafe Online Backup (Optional)



NOTE: Dell DataSafe Online Backup may not be available in all regions.



NOTE: A broadband connection is recommended for fast upload/download speeds.

Dell DataSafe Online is an automated backup and recovery service that helps protect your data and other important files from catastrophic incidents like theft, fire, or natural disasters. You can access the service on your computer using a password-protected account.

For more information, go to delldatasafe.com.

To schedule backups:

1. Double-click the Dell DataSafe Online icon  on the taskbar.
2. Follow the instructions that appear on the screen.



CHAPTER 7: SPECIFICATIONS

This chapter provides specifications of your desktop.

Computer Model

Alienware Aurora-R3

Dimensions

Height
(with top vents open) 432 mm (17 inches)

Width 249 mm (9.8 inches)

Depth 635 mm (25 inches)

Average weight 22.09 kg (48.7 lb)

NOTE: The weight of your desktop will vary depending on the configuration and the manufacturing variability.

Processor and System Chipset

Processor Intel Core i7
Intel Core i5
Intel Core i3

L2 cache 256 KB

L3 cache up to 8 MB

System chipset Intel P67

DMI speed 2.5 GT/s

DRAM bus width 64 bits

Processor address bus width 64 bits

Data bus bandwidth up to 6.4 GT/s

RAID support (internal SATA drives only) RAID 0
RAID 1
RAID 1+0

BIOS chip (NVRAM) 32 MB

Memory

Connectors	four internally-accessible DDR3 DIMM sockets
Capacities	1 GB, 2 GB, and 4 GB <i>1333 MHz, 1600 MHz, and 1866 MHz</i>
Minimum	3 GB
Maximum	16 GB
Memory types	2- channel DDR3

NOTE: For instructions on upgrading the memory, see “Removing and Replacing Memory Module(s)” on page 37.

Back Panel Connectors

IEEE 1394	one 6-pin serial connector
Network adapter	one RJ45 connector
USB	one 4-pin USB 3.0-compliant connector six 4-pin USB 2.0-compliant connectors
eSATA	one 4-pin connector
Audio	7.1 channel line output, stereo microphone, and stereo line input connectors
S/PDIF	one optical and one coaxial output connector

Top Panel Connectors

USB	one 4-pin USB 3.0-compliant connector two 4-pin USB 2.0-compliant connectors
Audio	one stereo headphone and microphone connectors

Communications

Network adapter	10/100/1000 Ethernet LAN on system board
Wireless (optional)	WiFi/Bluetooth wireless technology

Drives

Externally accessible	three 5.25-inch drive bays for a Blu-ray Disc combo, Blu-ray Disc Writer (6x), DVD+/-RW, DVD Combo, or Media Card Reader (optional)
Internally accessible	four 3.5-inch drive bays for SATA hard drives NOTE: Your computer supports up to two SATA 3.0 (6Gb/s) hard drives.

Expansion Bus

PCI Express x1:

Connectors	two
Connector size	36-pin connectors

PCI Express x16:

Connectors	two
Connector size	164 pins connectors

Audio

Type	integrated 7.1 channel, High Definition Audio with S/PDIF support
Controller	Realtek ALC892 codec

Video

Type	up to two graphic adapters - double-width, full length PCI Express x16
Operating speed	x16 with a single x16 video card x8/x8 with dual x16 video cards

Power

Voltage	100-240V AC
---------	-------------

NOTE: For information on voltage settings, see the safety information shipped with your computer.

Computer Environment

Temperature ranges:

Operating	10°C to 35°C (50°F to 95°F)
Storage	-10°C to 45°C (14°F to 113°F)
Relative humidity (maximum)	20% to 80% (noncondensing)

Maximum vibration (using a random-vibration spectrum that simulates user environment):

Operating	0.25 GRMS
Non-Operating	2.2 GRMS

Maximum shock (measured with hard drive in head-parked position and a 2-ms half-sine pulse):

Operating	40 G for 2 ms with a change in velocity of 20 in/s (51 cm/s)
Non-Operating	50 G for 26 ms with a change in velocity of 320 in/s (813 cm/s)

Altitude (maximum):

Operating	-15.2 to 3048 m (-50 to 10,000 ft)
Storage	-15.2 to 10,668 m (-50 to 35,000 ft)
Airborne contaminant level	G2 or lower as defined by ISA-S71.04-1985

APPENDIX A: GENERAL AND ELECTRICAL SAFETY PRECAUTIONS

Computer Setup

- Read all instructions marked on the product and in the documentation before operating your computer.
- Retain all safety and operating instructions.
- Never use this product near water or a heat source.
- Only set-up the computer on a stable work surface.
- Only operate the computer using the power source type indicated on the rating label.
- Never block or cover any openings or fans in the computer case. These are required for ventilation.
- Never insert objects of any kind into the ventilation openings.
- Ensure that your computer is properly grounded when in use.
- Do not attempt to plug your computer into an outlet that is not properly grounded.
- If an extension cable is used with your computer, ensure that the total ampere rating on the computer does not exceed the maximum rating on the extension cable.

Computer Use

- Route the power cable and all cables away from where people might walk or trip over them. Do not allow anything to rest on the power cable.
- Do not spill anything on or into your computer.
- To avoid electrical shock, always unplug all power, modem and any other cables from the electrical outlets before handling the computer.

Electrostatic Discharge (ESD) Warning

Electrostatic Discharge (ESD) can cause damage to internal system components if precautions are not taken. ESD is caused by static electricity and the damage caused is usually permanent.

Computer technicians wear a special wrist-strap that grounds them to the computer's case to prevent ESD damage. You can reduce the chances of ESD damage by doing the following:

- Turn off your computer's power and wait several minutes before starting to work.
- Ground yourself by touching the case of the computer.
- Touch only those items which must be replaced.
- Avoid walking around while replacing items inside the case, especially if you are on a carpet or during low temperature and low humidity.
- If you have to remove peripheral cards for any reason, place them on the portion of the computer's case that was removed. Do not touch the connectors at the bottom of the card that connect to the system board.

General Safety Precautions

- **Mechanical Shock:** Your computer should never be subjected to severe mechanical shocks. Careless handling of your computer may cause damage. Mechanical Shock is not covered by the warranty.
- **Electrical Shock:** If you do not open up your computer, there is nothing to worry about. Your computer protects itself against most irregularities in the power source.

When Should You Contact Alienware?

- The power cable or plug is damaged.
- Your computer has had liquid spilled into it.
- Your computer was dropped or the case was damaged.
- Normal operation of the computer does not occur when the operating instructions are followed.

Replacement Components or Accessories

It is only advised to use replacement parts or accessories recommended by Alienware.

Retain all boxes that were originally shipped to you in case you need to return any merchandise.

APPENDIX B: CONTACTING ALIENWARE

For customers in the United States/Canada, call 1-800-ALIENWARE.



NOTE: If you do not have an active Internet connection, you can find contact information on your purchase invoice, packing slip, bill, or Dell product catalog.

Dell provides several online and telephone-based support and service options. Because availability varies by country and product, some services may not be available in your area.

To contact Dell for sales, technical support, or customer service issues:

1. Visit www.dell.com/contactdell.
2. Select your country or region.
3. Select the appropriate service or support link based on your need.
4. Choose the method of contacting Dell that is convenient for you.

Websites

You can learn about Alienware products and services on the following websites:

- www.dell.com
- www.dell.com/ap (Asian/Pacific countries only)
- www.dell.com/jp (Japan only)
- www.euro.dell.com (Europe only)
- www.dell.com/la (Latin American and Caribbean countries)
- www.dell.ca (Canada only)

You can access Alienware Support through the following websites:

- support.dell.com
- support.jp.dell.com (Japan only)
- support.euro.dell.com (Europe only)
- support.la.dell.com (Argentina, Brazil, Chile, Mexico)

Information for NOM, or Official Mexican Standard (Only for Mexico)

The following information is provided in the device(s) described in this document in accordance with the requirements of the Official Mexican Standard (NOM):

Importer:

Dell México S.A. de C.V.
Paseo de la Reforma 2620 - Flat 11°
Col. Lomas Altas
11950 México, D.F.

Regulatory Model Number	Regulatory Type	Voltage	Frequency	Output Intensity
D01M	D01M003	100-240V AC	50-60 Hz	10.0 A/7.9 A

For details, read the safety information that shipped with your computer.

For additional safety best practices information, see www.dell.com/regulatory_compliance.

