

Dell Edge Gateway 3003

Installation and Operation Manual

Computer Model: Dell Edge Gateway 3003
Regulatory Model: N03G
Regulatory Type: N03G001



Notes, cautions, and warnings

 **NOTE:** A NOTE indicates important information that helps you make better use of your product.

 **CAUTION:** A CAUTION indicates either potential damage to hardware or loss of data and tells you how to avoid the problem.

 **WARNING:** A WARNING indicates a potential for property damage, personal injury, or death.

Contents

1 Overview.....	5
2 System views.....	6
Top view.....	6
Bottom view.....	7
Left view.....	7
Right view.....	10
3 Installing your Edge Gateway.....	11
Safety and regulatory information.....	11
Professional installation instructions.....	12
Instructions d'installation professionnelles.....	12
Federal Communication Commission interference statement.....	12
Industry Canada statement.....	13
Setting up your Edge Gateway.....	14
Activating your mobile broadband service.....	20
Mounting your Edge Gateway.....	21
Mounting the Edge Gateway using the standard-mount bracket.....	21
Mounting the Edge Gateway using quick-mount bracket.....	28
Attaching the cable control bars to the standard-mount bracket.....	36
Mounting the Edge Gateway on a DIN rail using the DIN-rail bracket.....	39
Mounting the Edge Gateway using the perpendicular mount.....	42
Mounting the Edge Gateway using a VESA mount.....	45
4 Setting up the ZigBee dongle.....	47
5 Setting up the operating system.....	48
Windows 10 IoT Enterprise LTSB 2016.....	48
Boot up and login – Direct system configuration.....	48
Boot up and login—Static IP system configuration.....	48
Restoring Windows 10 IoT Enterprise LTSB 2016.....	49
Windows 10 IOT Enterprise LTSB 2016 basic functions.....	49
Ubuntu Core 16.....	50
Overview.....	50
Boot up and log in – Direct system configuration	50
Boot up and log in – Static IP system configuration.....	51
Updating operating system and applications.....	51
Additional Ubuntu commands.....	51
Ubuntu Network Manager.....	52
Security.....	56
Watchdog Timer (WDT).....	56
Cloud LED On/Off.....	57



Global Positioning Systems (GPS).....	57
Snappy auto update/Autopilot.....	57
Accessing Snappy Store/Snapweb.....	57
Sensors.....	59
Ignition Pin.....	60
System Power Management.....	60
Restoring Ubuntu Core 16.....	61
Flashing a new OS image.....	63
Creating the recovery USB flash drive.....	63
6 Accessing and updating BIOS.....	65
Accessing BIOS settings.....	65
Entering BIOS setup during POST.....	65
Updating BIOS.....	65
Using the USB invocation script.....	66
Flashing the BIOS from a USB flash drive.....	66
Updating the BIOS on a Windows system.....	66
Using UEFI capsule update on an Ubuntu system.....	66
Dell Command Configure (DCC).....	67
Edge Device Manager (EDM).....	67
Default BIOS settings.....	68
General (BIOS level 1).....	68
System configuration (BIOS level 1).....	69
Security (BIOS level 1).....	70
Secure boot (BIOS level 1).....	71
Performance (BIOS level 1).....	71
Power management (BIOS level 1).....	72
POST behavior (BIOS level 1).....	72
Virtualization support (BIOS level 1).....	72
Maintenance (BIOS level 1).....	73
System logs (BIOS level 1).....	73
7 References.....	74
8 Appendix.....	75
Antenna specifications.....	75
De-mounting from DIN-rail bracket.....	76
Connecting to the Edge Gateway.....	77
Windows 10 IoT Enterprise LTSB 2016.....	77
Ubuntu Core 16.....	77
9 Contacting Dell.....	79



Overview

The Edge Gateway 3000 Series is an Internet-of-Things (IoT) device. It is mounted at the edge of a network, enabling you to collect, secure, analyze, and act on data from multiple devices and sensors. It enables you to connect with devices used in transportation, building automation, manufacturing, and other applications. The Edge Gateway has a low-power architecture, which is capable of supporting industrial automation workloads while remaining fanless to satisfy environmental and reliability requirements. It supports Windows 10 IoT Enterprise LTSC 2016 and Ubuntu Core 16 operating systems.



System views

Top view

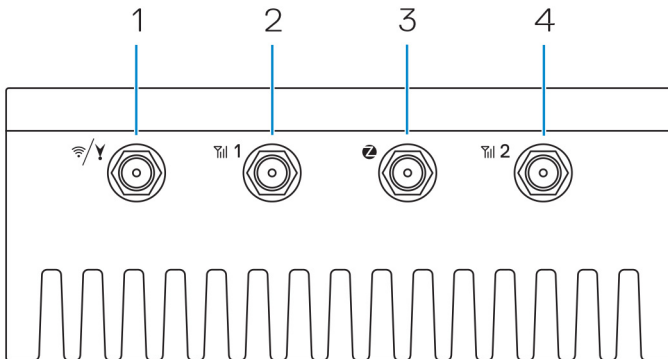

Table 1. Top view

Features		
1	WLAN, Bluetooth, or GPS connector	Connect the antenna to increase the range and strength of wireless, Bluetooth, or satellite signals.
2	Mobile broadband antenna-connector one (3G/LTE)	Connect the mobile broadband antenna to increase the range and strength of mobile broadband signals.
3	ZigBee antenna connector	Connect the ZigBee antenna for intermittent data transmissions from a ZigBee-compliant sensor or input device.
4	Mobile broadband antenna-connector two (LTE Auxiliary only)	Connect the mobile broadband antenna to increase the range and strength of mobile broadband signals.

NOTE: Depending on the configuration ordered, some of the antenna connectors may not be present or may be capped. For more information about connecting antennas to the Edge Gateway, see the documentation that is shipped with the antenna.

Bottom view

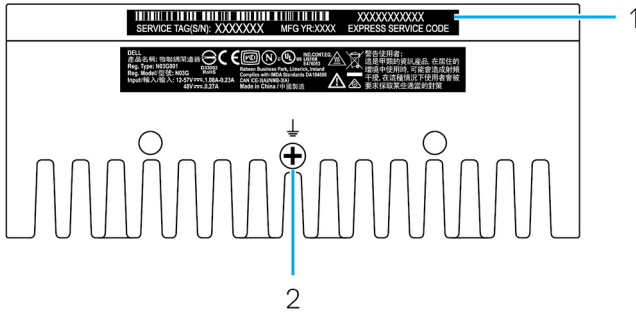

Table 2. Bottom view

Features		
1	Service Tag label	The Service Tag is a unique alphanumeric identifier that enables the Dell service technicians to identify the hardware components in your Edge Gateway and access warranty information.
2	Earth ground	A large conductor attached to one side of the power supply, which serves as the common return path for current from many different components in the circuit.

Left view

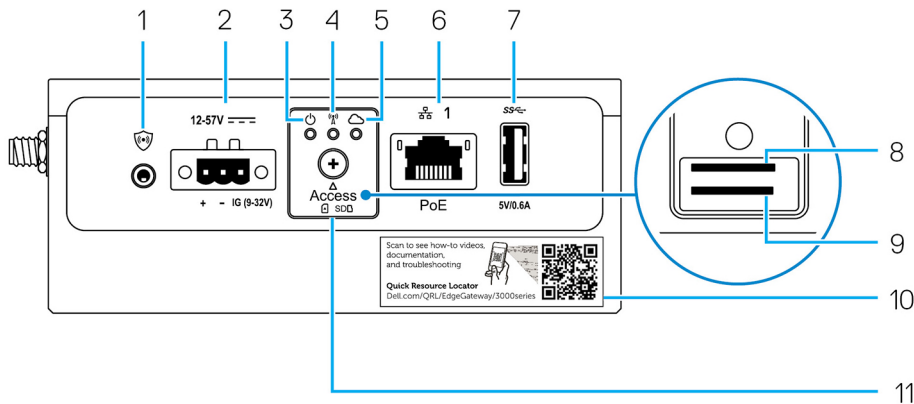









Table 3. Left view

Features		
1	Intrusion switch	An intrusion event is triggered when the enclosure (in which the Edge Gateway is installed) is opened.
<p> NOTE: External enclosure is sold separately.</p>		

Features

		<p> NOTE: An intrusion event is triggered by a third-party enclosure to the Edge Gateway through a sensor. The sensor should have a cable that is compatible with the intrusion switch connector on the Edge Gateway.</p>
2	Power or ignition port	<p>Connect a 12-57 VDC (1.08-0.23 A) power cable to supply power to the Edge Gateway.</p> <p> NOTE: Power cable is sold separately.</p> <p> NOTE: For marine applications, limit input voltage to 12-48 VDC. The cable length for rail applications must not exceed 30 meters.</p>
3	Power and System status light	Indicates the power status and system status.
4	WLAN or Bluetooth status light	Indicates if WLAN or Bluetooth is ON or OFF.
5	Cloud-connection status light	Indicates the cloud connection status.
6	Ethernet port one (with Power over Ethernet support)	<p>Connect an Ethernet (RJ45) cable to gain network access. Provides data transfer speeds up to 10/100 Mbps and supports Alternative A of the IEEE 802.3af standard.</p> <p> NOTE: The Edge Gateway is an IEEE 802.3af Alternative A compliant Powered Device (PD).</p> <p> NOTE: To comply with EU Declaration of Conformity (DoC), ensure cable length from the system to the device does not exceed 30 meters.</p> <p> NOTE: To comply with regulatory requirements in Brazil, ensure cable length from the system to the device does not exceed 10 meters.</p>
7	USB 3.0 port ¹	Connect a USB enabled device. Provides data transfer speeds up to 5 Gbps.
8	SIM card slot (optional)	Insert a micro-SIM card into the slot.
9	SD card slot (optional)	<p>Insert a micro-SD card into the slot.</p> <p> NOTE: Remove the SD card slot filler before inserting a micro-SD card.</p>
10	Quick Resource Locator label	Scan with a QR reader to access documentation and other system information.
11	micro-SIM or micro-SD card access door	Open the access door to access the micro-SIM or micro-SD card.

¹ USB power is limited to 0.6 A/3 W.

Table 4. Status-light indicators

Function	Indicator	Color	Control	Status
System	Power status and System status	Green or Amber	BIOS	<p>Off: System off</p> <p>On (Solid Green): System on or Boot successful</p> <p>On (Solid Amber): Power up or boot fail</p> <p>Blinking Amber: Fault or error</p>

Function	Indicator	Color	Control	Status
	WLAN or Bluetooth	Green	Hardware	Off: WLAN or Bluetooth module is off On: WLAN or Bluetooth module is on
	Cloud	Green	Software	Off: No connection to the cloud device or service On: Edge Gateway connected to a cloud device or service Blinking Green: Activity to a cloud device or service
LAN (RJ-45)	Link	Green/Amber	Driver (LAN)	Off: No network link or cable is not connected On (Green): High-speed connection (100 Mbps) On (Amber): Low-speed connection (10 Mbps)
	Activity	Green	Driver (LAN)	Off: No activity on link Blinking Green: LAN activity. The blink rate is related to packet density.

NOTE: The power and system status light may operate differently during different boot-up scenarios, for example, when a USB script file is run during boot-up.

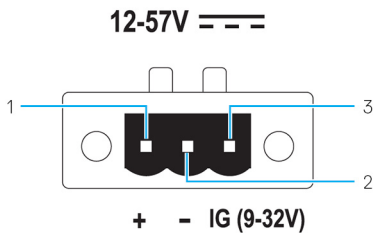

Table 5. Power connector pin definition details

Pin	Signal	Function
1	DC+	12–57 VDC power
2	DC–	Ground
3	IG	9–32 VDC ignition

NOTE: Pin 3 (IG) is connected to the vehicle's ignition status indicator (optional) or a wake pin. A voltage of more than 9 V on the signal indicates that the vehicle's engine is running. The Ignition or Wake pin is used to prevent the draining of the vehicle battery when the vehicle is turned off for an extended amount of time.

NOTE: The IG signal can be used to gracefully shutdown or enter low-power state when the vehicle is turned off (battery powered). It can also be used for powering on the Edge Gateway when the vehicle starts.

Right view

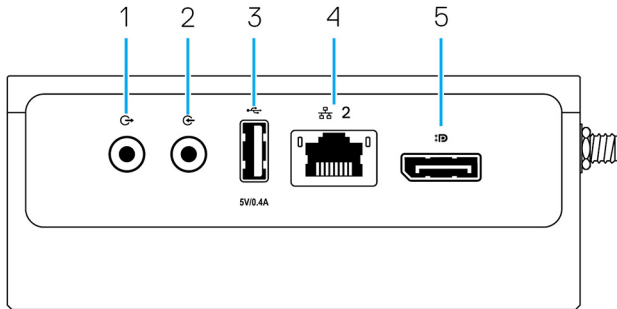

Table 6. Right view—3003











Features		
1	Audio line-out (GREEN)	Connect audio-output devices such as speakers and amplifiers.
2	Audio line-in (BLUE)	Connect recording or playback devices.
3	USB 2.0 port ¹	Connect a USB enabled device. Provides data transfer speeds up to 480 Mbps.
4	Ethernet port two (Non-PoE)	Connect an Ethernet (RJ45) cable for network access. Provides data transfer speeds up to 10/100 Mbps.
5	DisplayPort connector	Connect a monitor or another DisplayPort-enabled device. Provides video and audio output.

¹ USB power is limited to 0.4 A/2 W.

Installing your Edge Gateway

 **WARNING:** Before you begin any of the procedures in this section, read the [safety and regulatory information](#) that is shipped with your system. For additional best practices information, go to www.dell.com/regulatory_compliance.

Safety and regulatory information

-  **WARNING:** The Edge Gateway must be installed by knowledgeable, skilled persons familiar with local and/or international electrical codes and regulations.
-  **WARNING:** The Edge Gateway is not designed for use in wet environments. If the Edge Gateway is to be installed in a wet environment, depending on the location and environment, it must be installed in a panel box or enclosure with an Ingress Protection (IP) rating of IP54, IP65, or higher.
-  **WARNING:** To reduce the risk of electric shock, power to the DC+ and DC- terminals must be provided by a power supply or transformer/rectifier circuit that is designed with double-insulation. The power supply or power circuit source must comply with local codes and regulations; for example, in the USA, NEC Class 2 (SELV/limited energy circuit, or LPS circuitry). If powered by a battery, double-insulation is not required.
-  **WARNING:** When installing the Edge Gateway, the responsible party or integrator shall use the 12-57 VDC or Power over Ethernet (PoE) power source 37-57 VDC, with a minimum of 13 W power already present as part of the client's installation.
-  **WARNING:** Ensure that the power source providing power to the Edge Gateway is reliably grounded and filtered such that the peak-to-peak ripple component is less than 10 percent of the input DC voltage.
-  **WARNING:** When installing the Edge Gateway 3003, use a cable appropriate for the load currents: 3-core cable rated 5 A at 90°C (194°F) minimum, which conform to either IEC 60227 or IEC 60245. The system accepts cables from 0.8 mm to 2 mm. The maximum operating temperature of the Edge Gateway is 60°C (140°F). Do not exceed this maximum temperature while operating the Edge Gateway inside an enclosure. Internal heating of the Edge Gateway electronics, other electronics, and the lack of ventilation inside an enclosure can cause the operating temperature of the Edge Gateway to be greater than the outside ambient temperature. Continuous operation of the Edge Gateway at temperatures greater than 60°C (140°F) may result in an increased failure rate and a reduction of the product life. Ensure that the maximum operating temperature of the Edge Gateway when placed inside an enclosure is 60°C (140°F) or less.
-  **WARNING:** Always ensure that the available power source matches the required input power of the Edge Gateway. Check the input power markings next to power connector(s) before making connections. The 12-57 VDC (1.08-0.23 A) or the PoE power source must be compliant with local Electrical Codes and Regulations.
-  **WARNING:** To ensure the protection provided by the Edge Gateway is not impaired, do not use or install the system in any manner other than what is specified in this manual.
-  **WARNING:** If a battery is included as part of the system or network, the battery must be installed within an appropriate enclosure in accordance with local fire and electrical codes and laws.
-  **WARNING:** The system is for installation in a suitable industrial enclosure (provides electrical, mechanical, and fire hazard protection).
-  **WARNING:** The core module only can be wall-mounted (without the need for an additional enclosure).



Professional installation instructions

Installation personnel

This product is designed for specific applications and needs to be installed by qualified personnel with RF and regulatory-related knowledge. The general user shall not attempt to install or change the setting.

Installation location

The product shall be installed at a location where the radiating antenna is kept 20 cm from nearby persons in its normal operation condition in order to meet regulatory RF exposure requirements.

External antenna

Use only approved antenna(s). Non-approved antenna(s) may produce spurious or excessive RF transmitting power which may lead to a violation of FCC/IC limits.

Installation procedure

Refer to user's manual for installation instructions.



WARNING: Carefully select the installation position and make sure that the final output power does not exceed the limits described in the product's documentation. The violation of these rules could lead to serious federal penalties.

Instructions d'installation professionnelles

Le personnel d'installation

Ce produit est conçu pour des applications spécifiques et doit être installé par un personnel qualifié avec RF et connaissances connexes réglementaire. L'utilisateur ne doit pas tenter générale d'installer ou de modifier le réglage.

Lieu d'installation

Le produit doit être installé à un endroit où l'antenne de rayonnement est maintenue à 20 cm de personnes à proximité dans son état de fonctionnement normal, afin de répondre aux exigences réglementaires d'exposition aux radiofréquences.

Antenne externe

Utilisez uniquement l'antenne(s) qui ont été approuvés par le demandeur. Antenne (s) peuvent produire de l'énergie RF parasite indésirable ou excessive transmission qui peut conduire à une violation des normes de la FCC / IC est interdite et non-approuvé.

Procédure d'installation

ATTENTION: S'il vous plaît choisir avec soin la position d'installation et assurez-vous que la puissance de sortie final ne dépasse pas les limites fixées dans les règles pertinentes. La violation de ces règles pourrait conduire à des sanctions fédérales graves.

Federal Communication Commission interference statement

This device complies with Part 15 of the FCC Rules. Operation is subject to the following two conditions: (1) This device may not cause harmful interference, and (2) this device must accept any interference received, including interference that may cause undesired operation.

This equipment has been tested and found to comply with the limits for a Class A digital device, pursuant to Part 15 of the FCC Rules. These limits are designed to provide reasonable protection against harmful interference in a residential installation. This equipment generates, uses, and can radiate radio frequency energy and, if not installed and used in accordance with the instructions,

may cause harmful interference to radio communications. However, there is no guarantee that interference will not occur in a particular installation. If this equipment does cause harmful interference to radio or television reception, which can be determined by turning the equipment off and on, the user is encouraged to try to correct the interference by one of the following measures:

- Reorient or relocate the receiving antenna.
- Increase the separation between the equipment and receiver.
- Connect the equipment into an outlet on a circuit different from that to which the receiver is connected.
- Consult the dealer or an experienced radio/TV technician for help.

FCC caution:

- Any changes or modifications not expressly approved by the party responsible for compliance could void the user's authority to operate this equipment.
- This transmitter must not be co-located or operating in conjunction with any other antenna or transmitter.

Radiation exposure statement:

This equipment complies with FCC radiation exposure limits for an uncontrolled environment. This equipment should be installed and operated with a minimum distance of 20 cm between the active transceiver and your body.

 **NOTE: The country code selection is for a non-US model only and is not available to all US model. Per FCC regulation, all WiFi products marketed in the US must be fixed to US operation channels only.**

Industry Canada statement

This device complies with Industry Canada license-exempt RSS standard(s). Operation is subject to the following two conditions:

1. this device may not cause interference, and
2. this device must accept any interference, including interference that may cause undesired operation of the device.

Le présent appareil est conforme aux CNR d'Industrie Canada applicables aux appareils radio exempts de licence. L'exploitation est autorisée aux deux conditions suivantes:

1. l'appareil ne doit pas produire de brouillage, et
2. l'utilisateur de l'appareil doit accepter tout brouillage radioélectrique subi, même si le brouillage est susceptible d'en compromettre le fonctionnement.

Under Industry Canada regulations, the radio transmitter(s) may only operate using an antenna(s) of a type and maximum (or lesser) gain approved for the transmitter(s). To reduce potential radio interference to other users, the antenna type(s) and gain(s) should be chosen so that the Equivalent Isotropic Radiated Power (E.I.R.P.) is not more than what was approved for the transmitter(s).

This Class A digital apparatus complies with Canadian ICES-003.

Cet appareil numérique de la classe A est conforme à la norme NMB-003 du Canada.

This device complies with RSS-210 of Industry Canada. Operation is subject to the condition that this device does not cause harmful interference.

Cet appareil est conforme à la norme RSS-210 d'Industrie Canada. L'opération est soumise à la condition que cet appareil ne provoque aucune interférence nuisible.

This device and its antenna(s) must not be co-located or operating in conjunction with any other antenna or transmitter, except tested built-in radios.

Cet appareil et son antenne ne doivent pas être situés ou fonctionner en conjonction avec une autre antenne ou un autre émetteur, exception faites des radios intégrées qui ont été testées.

The County Code Selection feature is disabled for products marketed in the US/Canada.



La fonction de sélection de l'indicatif du pays est désactivée pour les produits commercialisés aux États-Unis et au Canada.

Radiation Exposure Statement: This equipment complies with IC radiation exposure limits set forth for an uncontrolled environment. This equipment should be installed and operated with minimum distance of 20 cm between the active transceiver and your body.

Déclaration d'exposition aux radiations: Cet équipement est conforme aux limites d'exposition aux rayonnements IC établies pour un environnement non contrôlé. Cet équipement doit être installé et utilisé avec un minimum de 20 cm de distance entre la source de rayonnement et votre corps.

Setting up your Edge Gateway

- 📌 **NOTE:** Edge Gateway mounting options are sold separately.
- 📌 **NOTE:** Mounting can be done before or after configuring your Edge Gateway. For more information about mounting your Edge Gateway, see [Mounting your Edge Gateway](#).
- 📌 **NOTE:** In some environments where the Edge Gateway may be installed, a more robust mounting method is required. For example, for mounting in marine applications, it is recommended to use only the standard— mount bracket. The recommendation is due to the presence of vibrations unique to the marine environment.

1. Use USB cables to connect a display, keyboard, and mouse.

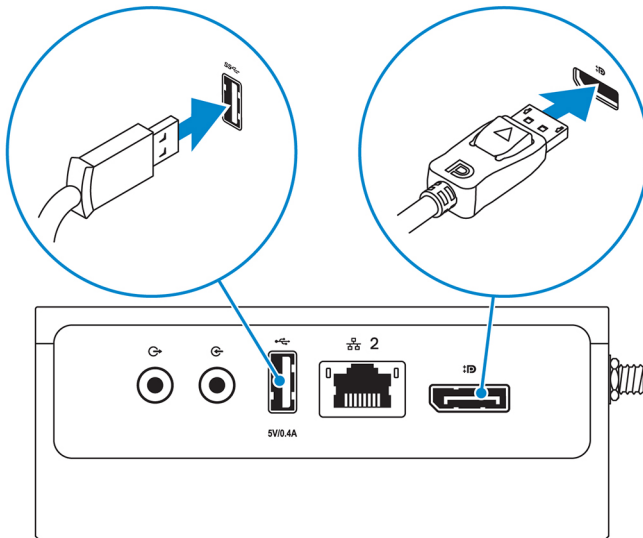

- 📌 **NOTE:** USB power is limited to 0.6 A/3 W for USB 3.0 port and 0.4 A/2 W for USB 2.0 port to ensure that the Edge Gateway is within the allowed 13 W PoE Class 0 range.



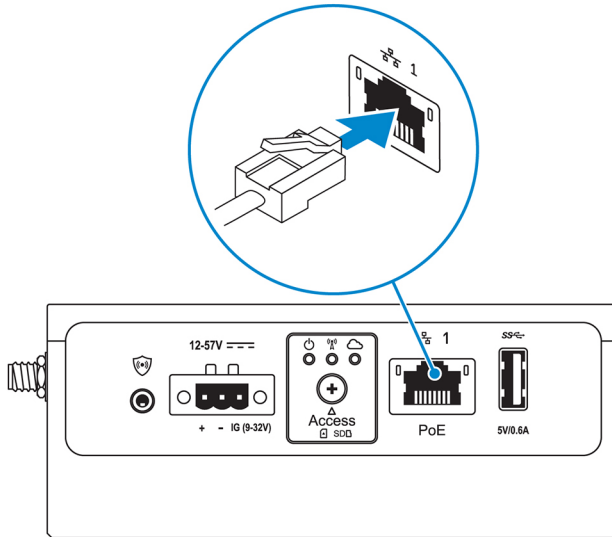

2. Connect an Ethernet cable to Ethernet port one.

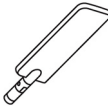

3. Connect the antennas depending on the configuration ordered (optional).

NOTE: The antennas supported in the Edge Gateway vary depending on the configuration ordered.

Table 7. Antennas supported in Edge Gateway 3003

Antennas supported				
Signals				
3003	Yes	Yes	Yes	Not applicable

NOTE: Use only the supplied antennas or third-party antennas that meet the [minimum specifications](#).

NOTE: Depending on the configuration ordered, some of the antenna connectors may not be present or may be capped.

NOTE: Mobile broadband antenna connector two is for LTE Auxiliary only; it does not support 3G.

4. Insert the antenna into the connector.

NOTE: If you are installing multiple antennas, follow the sequence indicated in the following image.

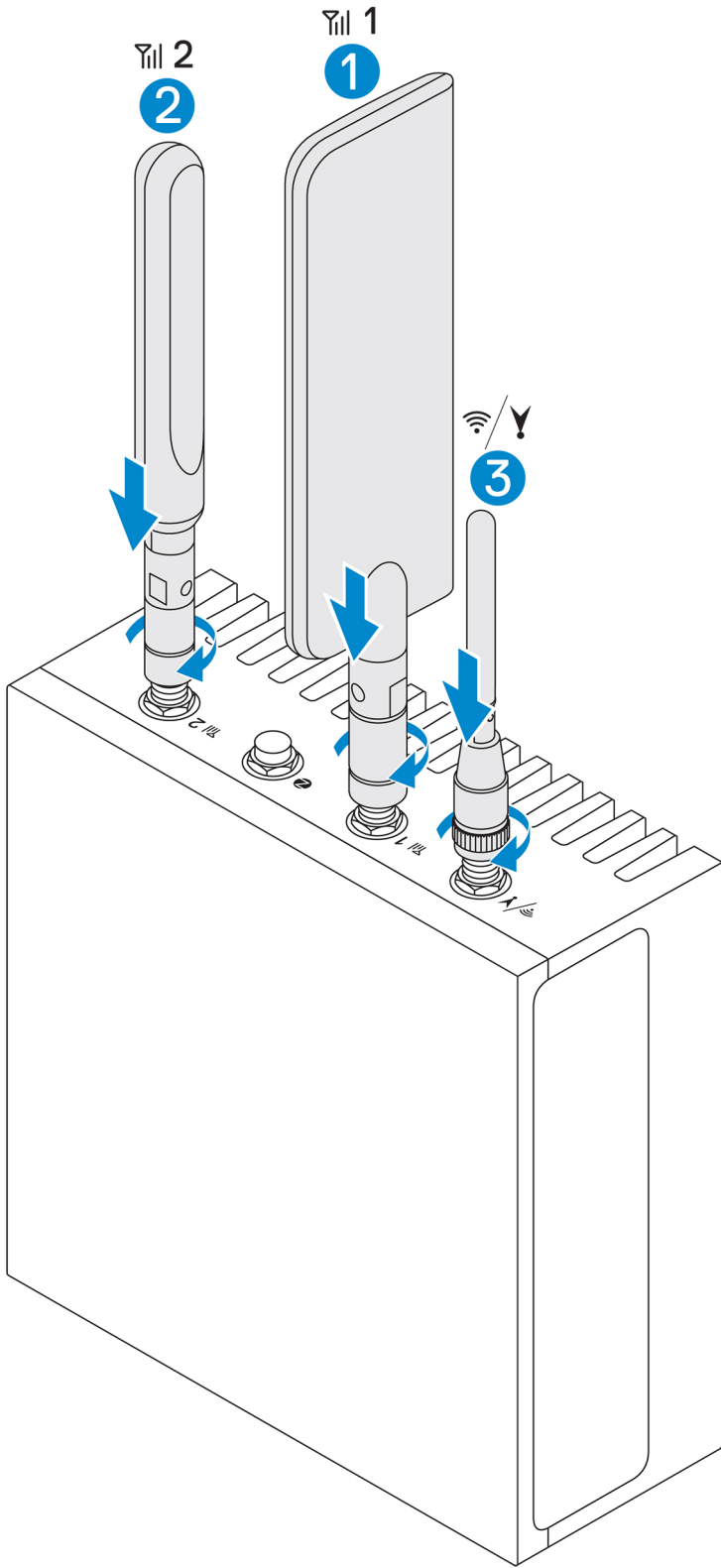

5. Secure the antenna by tightening the rotating head of the connector until it firmly holds the antenna in the preferred position (upright or straight).

 **NOTE: Antenna images are for illustrative purposes only. Actual appearance may differ from the images provided.**

6. Connect all desired cables to the appropriate I/O ports on the Edge Gateway.
7. Open the micro-SIM or micro-SD card access door.
8. Insert a micro-SIM card into the top micro-SIM card slot and [activate your mobile broadband service](#).

 **CAUTION: Dell recommends that you insert the micro-SIM card before turning on the Edge Gateway.**

 **NOTE: Ensure that you firmly screw back the access door after closing.**

 **NOTE: Contact your service provider to activate your micro-SIM card.**

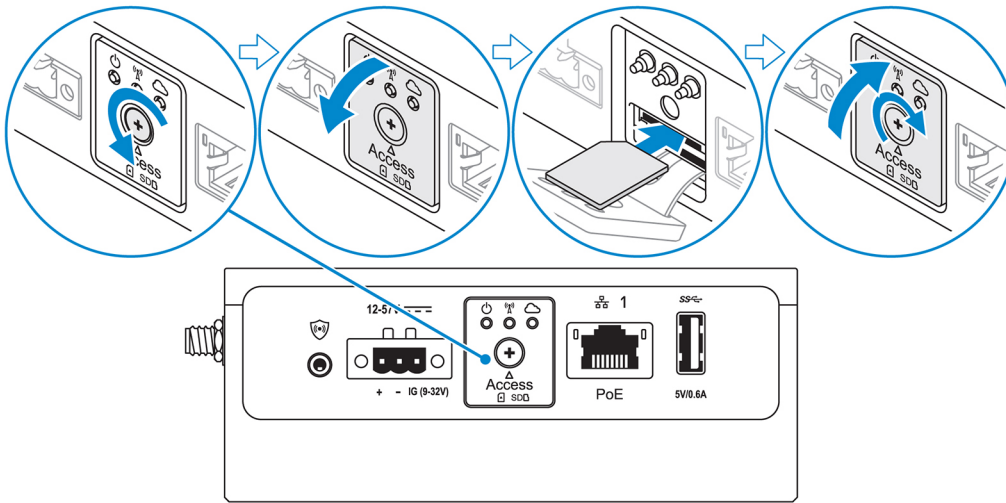

9. Insert a micro-SD card into the bottom micro-SD card slot.

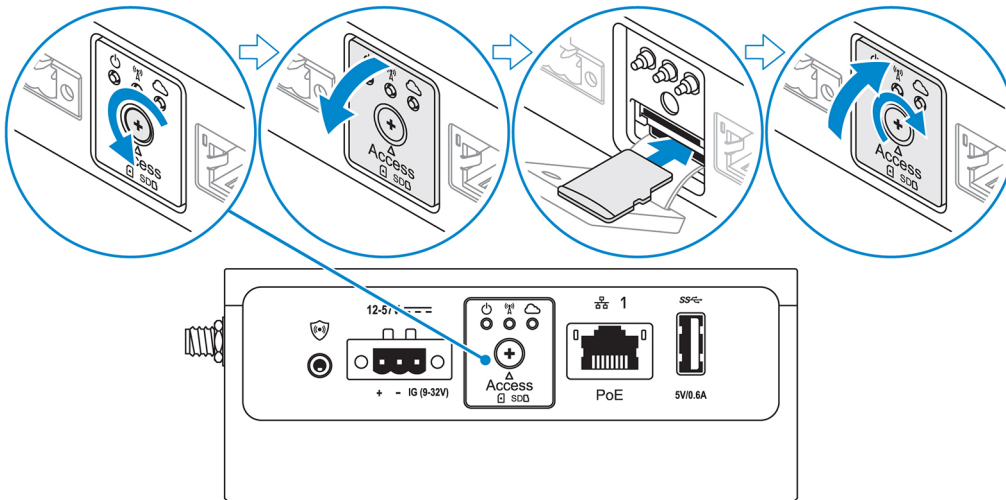

 **NOTE: Remove the SD card slot filler before inserting a micro-SD card.**

 **NOTE: Ensure that you firmly screw back the access door after closing.**

10. Connect a grounding cable between the Edge Gateway and the secondary enclosure.

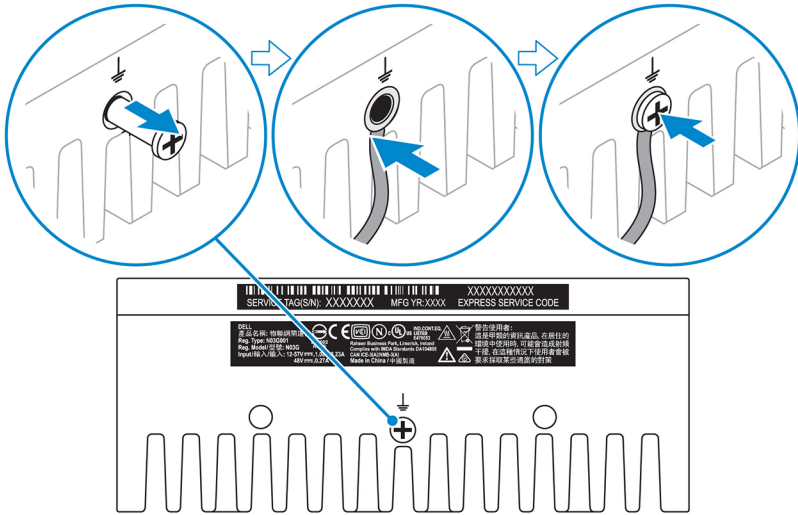

NOTE: Secondary enclosures are sold separately.

11. Connect the Edge Gateway to one of the following power sources:

- DC-IN

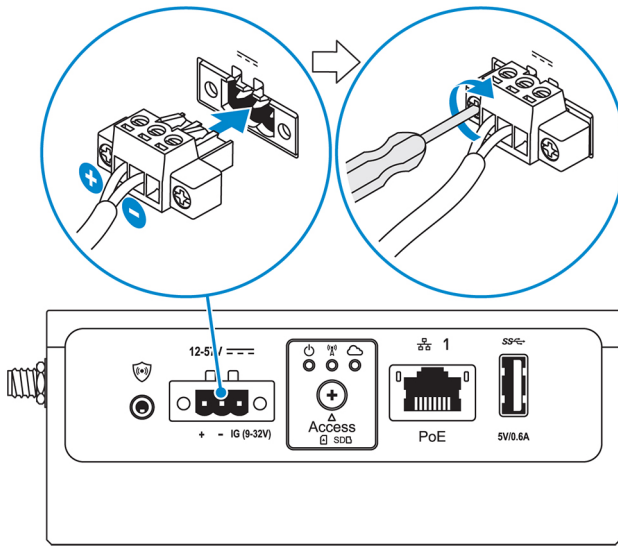

- PoE

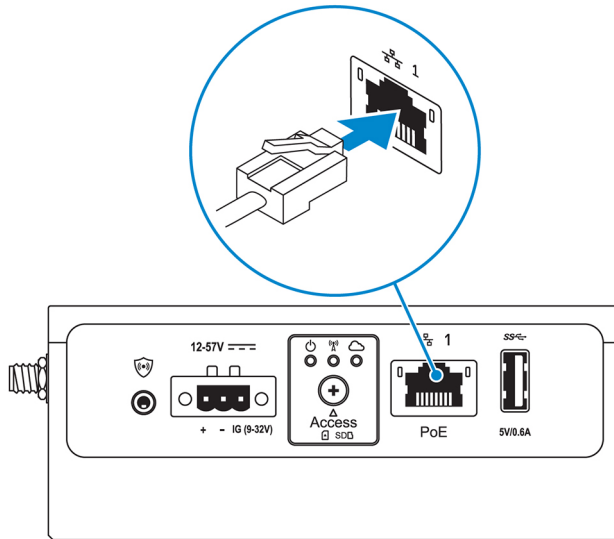

NOTE: Shut down your system before you change the power sources.

12. Replace the dust caps on any unused ports.
13. When setting up the Edge Gateway for the first time, complete the operating system setup.
For more information, see [Setting up your operating system](#).

NOTE: MAC addresses and the IMEI number are available on the label at the front of the Edge Gateway. Remove the label at install.

NOTE: The Edge Gateway is shipped with either Windows 10 IoT Enterprise LTSC 2016 or Ubuntu Core 16 operating system.

NOTE: The default user name and password for Windows 10 IoT Enterprise LTSC 2016 is *admin*.

NOTE: The default user name and password for Ubuntu Core 16 is *admin*.

14. Access the BIOS by pressing F2 to enter the BIOS setup or F12 to enter the BIOS boot menu.

Windows 10 IOT Enterprise LTSC 2016

Click **Start** → **All Programs** → **Dell** → **Command Configure** → **Dell Command | Configure Wizard**.

Ubuntu Core 16

Use the `dcc . cct.k` command to access the Dell Command | Configure application.

NOTE: For more information about BIOS settings on the Edge Gateway, see [Default BIOS settings](#).

15. Install the Edge Gateway using one of the following mounting options:

NOTE: An open space of 63.50 mm (2.50 in) is recommended around the Edge Gateway for optimal air circulation.

- [Standard mount](#)
- [DIN rail mount](#)
- [Quick mount](#)
- [Perpendicular mount](#)
- [Cable control bar](#)
- [VESA mount](#)



Activating your mobile broadband service

CAUTION: Before you power on the Edge Gateway, insert a micro-SIM card.

NOTE: Ensure that the service provider has already activated the micro-SIM card before you use it in the Edge Gateway.

1. Remove the screw to open the micro-SIM card access door.
2. Insert a micro-SIM card into the top micro-SIM card slot.

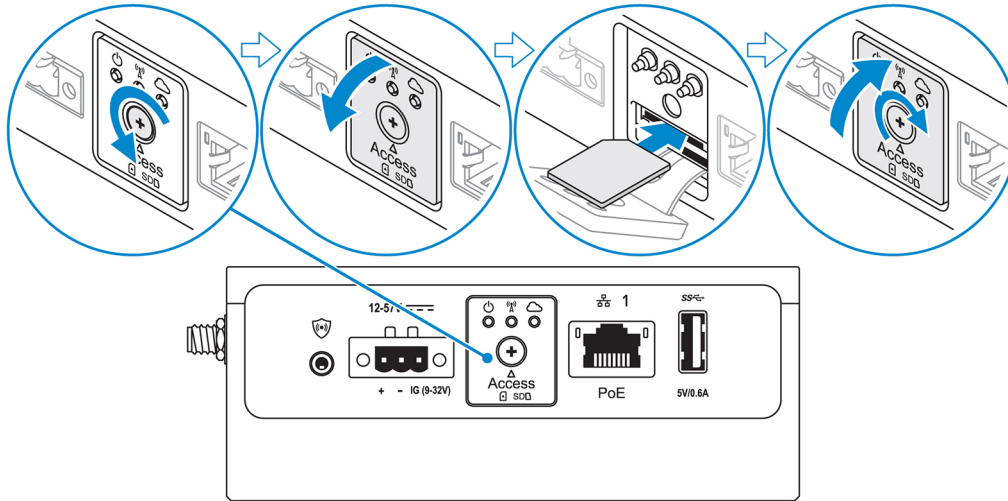

3. Replace the screw, and close the micro-SIM card access door.
4. Power on the Edge Gateway.
5. Connect to a mobile network.

Windows operating system

- a. Click the network icon from the taskbar, and then click **Cellular**.
- b. Select **Mobile Broadband Carrier** → **Advanced Options**.
- c. Make a note of the **International Mobile Equipment Identity (IMEI)** and **Integrated Circuit Card Identifier (ICCID)**.
- d. Enter your APN number and any other credentials that your service provider requires.

Ubuntu operating system

- a. Open the **Terminal** window.
- b. Enter `$sudo su -` to access super user mode.
- c. Configure the Mobile Broadband connection profile:

Command line:

```
network-manager.nmcli con add type <type> ifname <ifname> con-name <connection-name> apn <apn>
```

Example (Verizon):

```
network-manager.nmcli con add type gsm ifname cdc-wdm0 con-name VZ_GSMDEMO apn vzwinternet
```

Example (AT&T):

```
network-manager.nmcli con add type gsm ifname cdc-wdm0 con-name ATT_GSMDEMO apn broadband
```

Example (3G):

```
network-manager.nmcli con add type gsm ifname cdc-wdm0 con-name 3G_GSMDEMO apn internet
```

d. Connect to the mobile network:

Command line:

```
network-manager.nmcli con up <connection-name>
```

Example (Verizon):

```
network-manager.nmcli con up VZ_GSMDEMO
```

Example (AT&T):

```
network-manager.nmcli con up ATT_GSMDEMO
```

Example (3G):

```
network-manager.nmcli con up 3G_GSMDEMO
```

To disconnect from the mobile network:

Command line: `network-manager.nmcli con down <connection-name>`

Example (Verizon):

```
network-manager.nmcli con down VZ_GSMDEMO
```



Example (AT&T):

```
network-manager.nmcli con down ATT_GSMDEMO
```

Example (3G):

```
network-manager.nmcli con down 3G_GSMDEMO
```

Mounting your Edge Gateway

-  **NOTE:** Mounting can be completed before or after configuring your Edge Gateway.
-  **NOTE:** Mounting options are sold separately. Mounting instructions are available in the documentation shipped with the mounting device.
-  **NOTE:** In some environments where the Edge Gateway is installed, a more robust mounting method is required. For example, in marine applications, due to vibrations unique to that environment, only standard-mount bracket should be used.

Mounting the Edge Gateway using the standard-mount bracket

Mounting dimensions



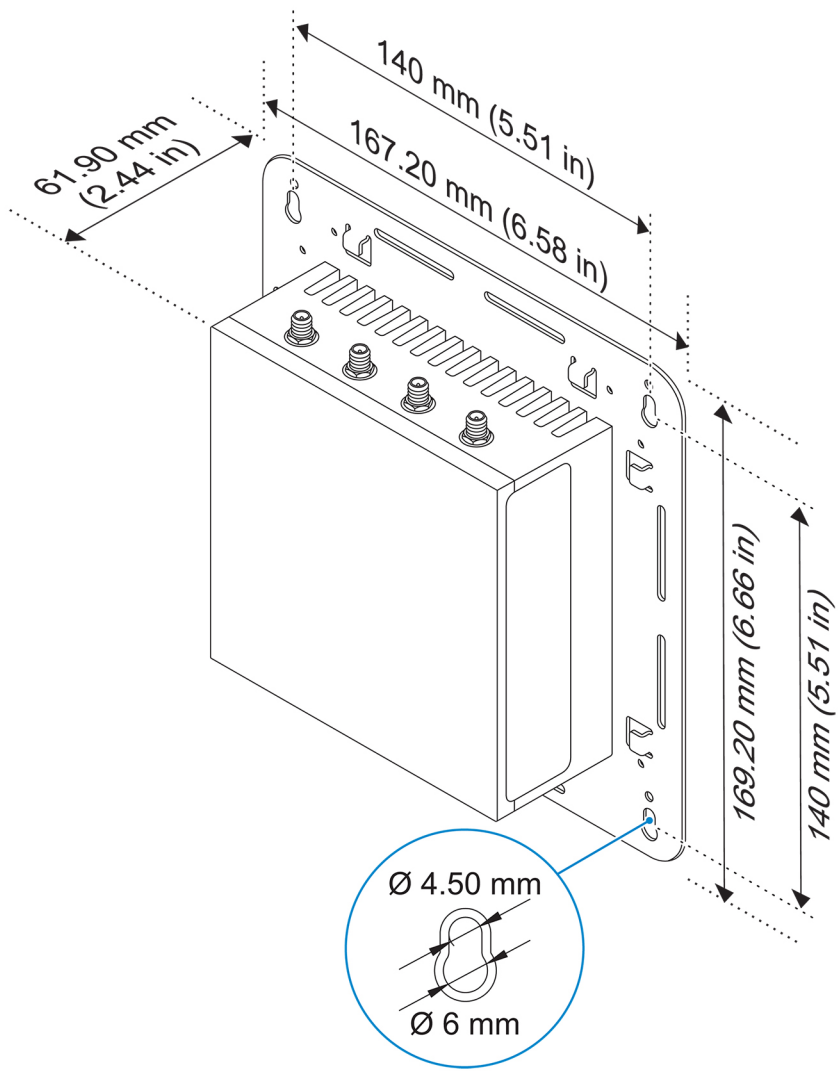

NOTE: The mounting brackets are shipped with only those screws that are required for securing the mounting brackets to the Edge Gateway.

1. Secure the standard-mount bracket to the back of the Edge Gateway using the four M4x4.5 screws.

NOTE: Torque the screws at 8 ± 0.5 kilograms-centimeter (17.64 ± 1.1 pounds-inch).

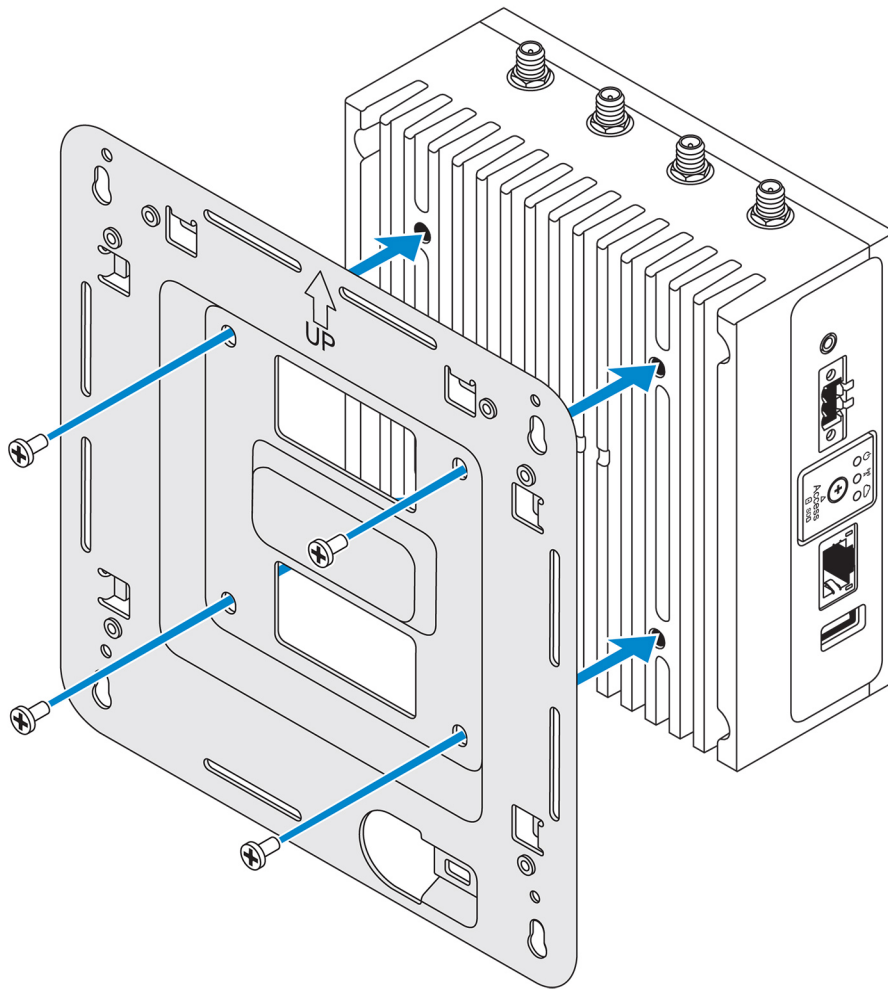

2. Place the Edge Gateway against the wall, and align the holes in the standard-mount bracket with the holes on the wall. Screw holes on the bracket have a diameter of 3 mm (0.12 in).

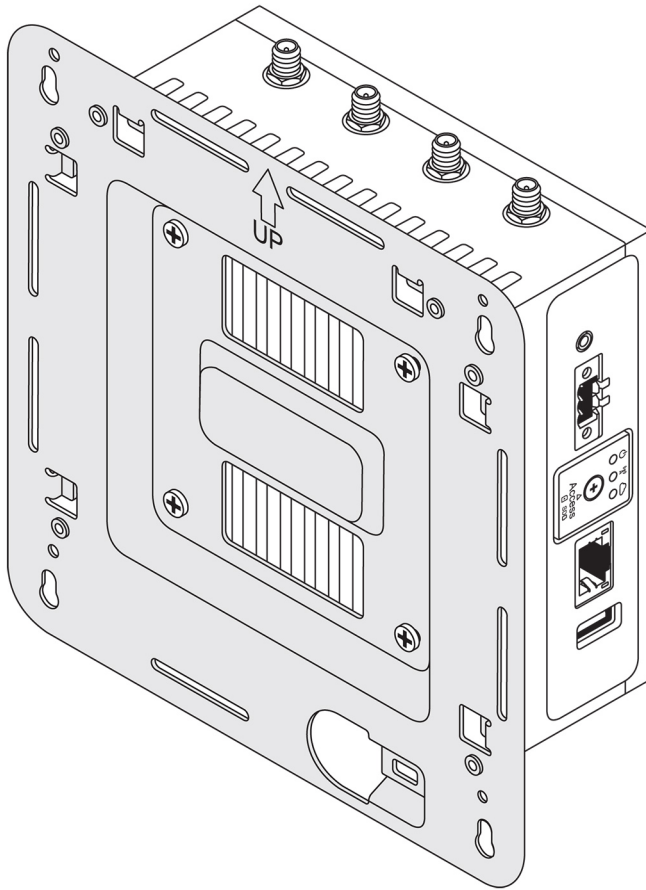

3. Place the standard-mount bracket on the wall, and using the holes above the screw holes on the bracket, mark the positions to drill the four holes.

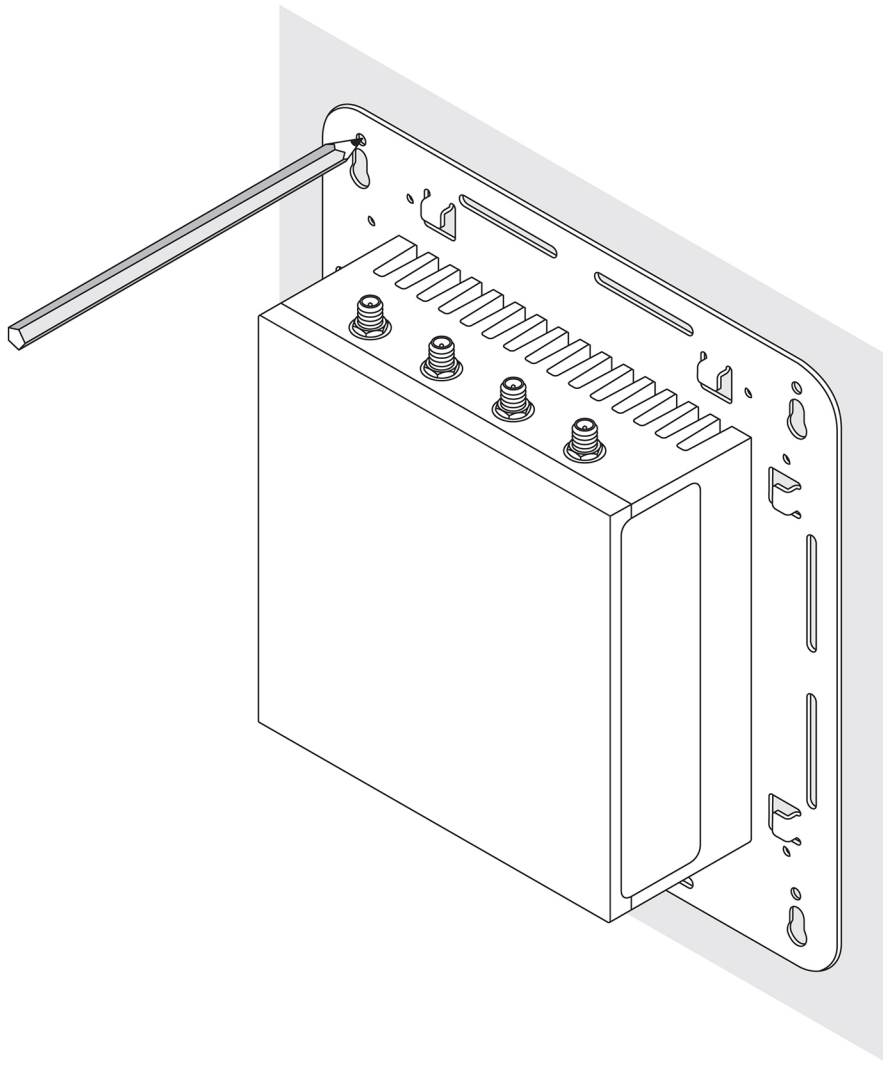

4. Drill four holes in the wall as marked.
5. Insert and tighten four screws (not supplied) to the wall.

 **NOTE: Purchase screws that fit the diameter of the screw holes.**

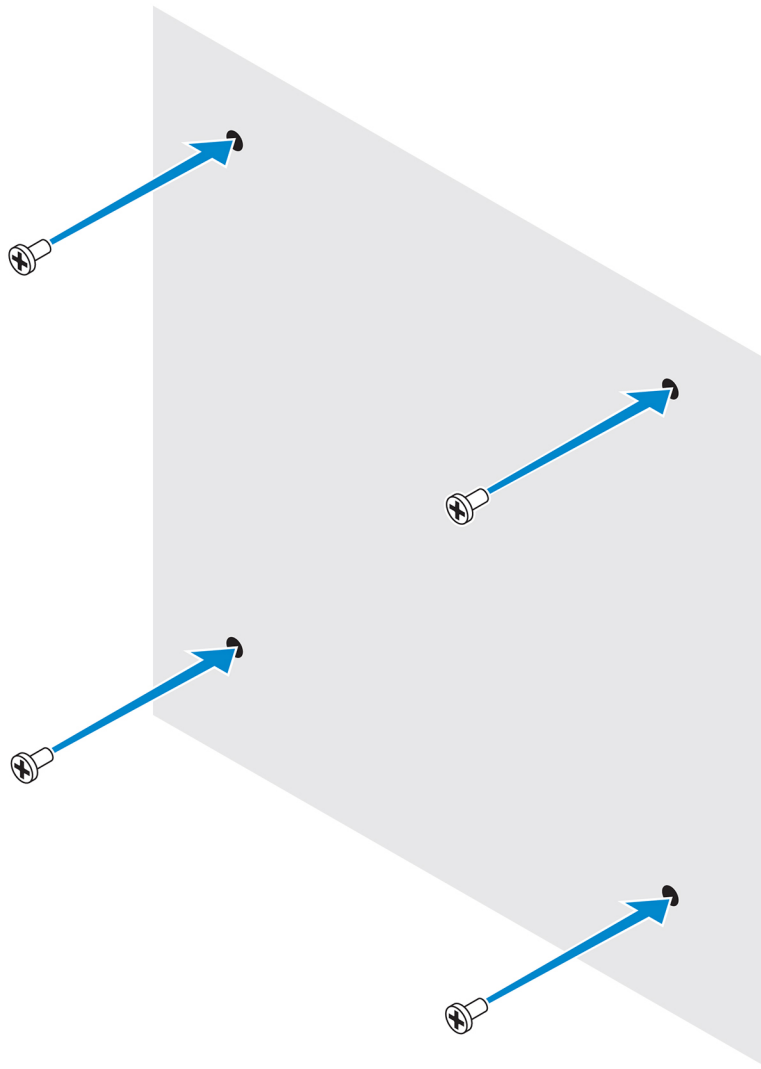

6. Align the screw holes on the standard-mount bracket with the screws and place the Edge Gateway onto the wall.

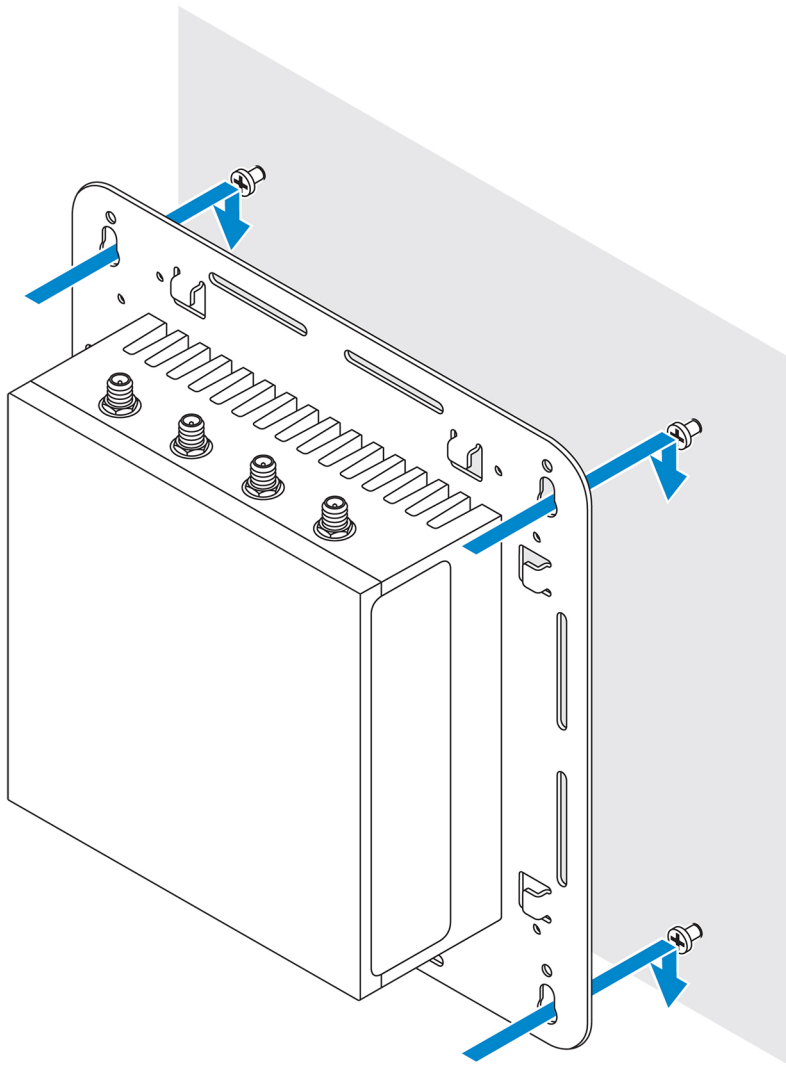

7. Tighten the screws to secure the assembly to the wall.

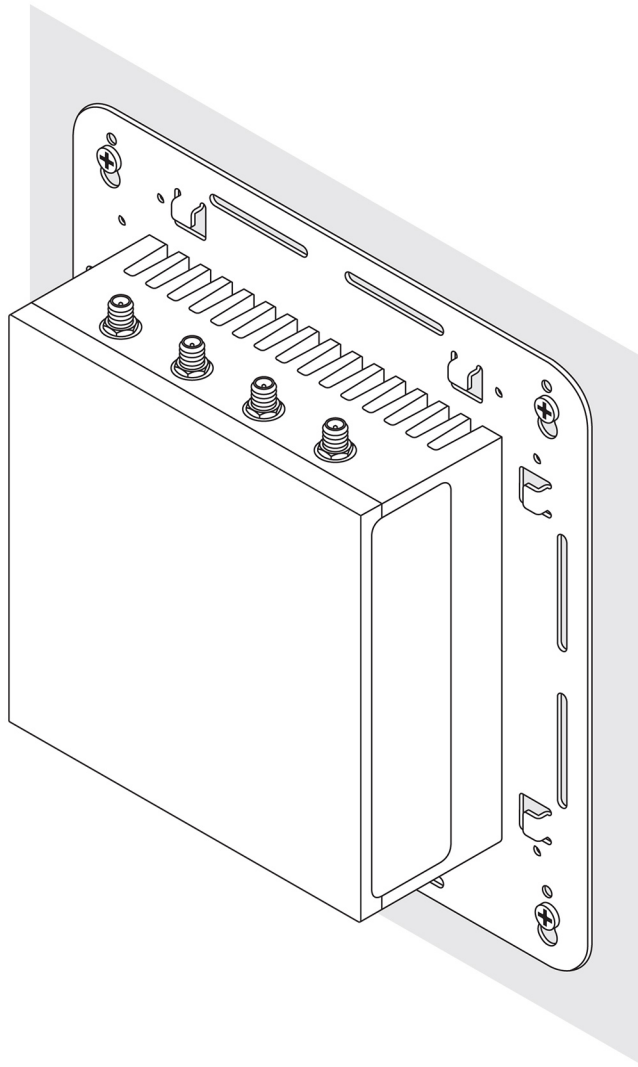

Mounting the Edge Gateway using quick-mount bracket

The quick-mount bracket is a combination of the standard-mount bracket and the DIN-rail bracket. It enables you to easily mount and demount the Edge Gateway.

 **NOTE:** The mounting brackets are shipped with only those screws required for securing the mounting brackets to the Edge Gateway.

Mounting dimensions

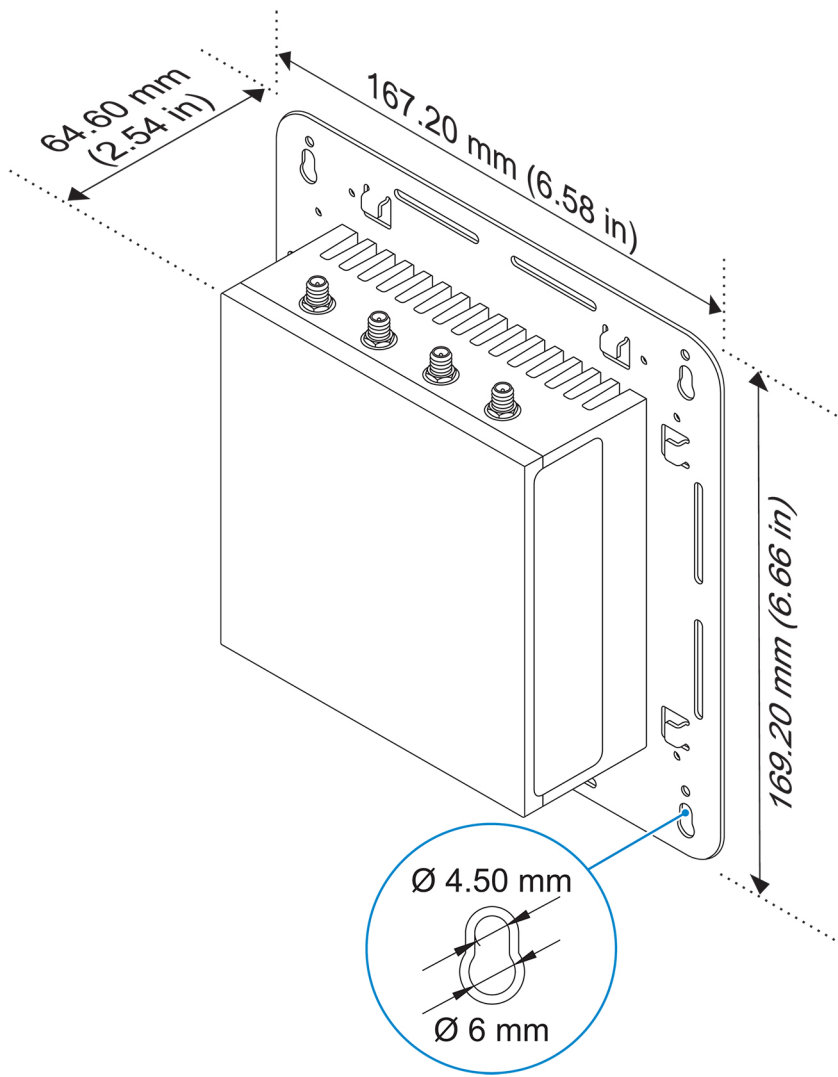

Mounting instructions

1. Place the standard-mount bracket on the wall, and using the holes above the screw holes on the bracket, mark the positions to drill the four holes.

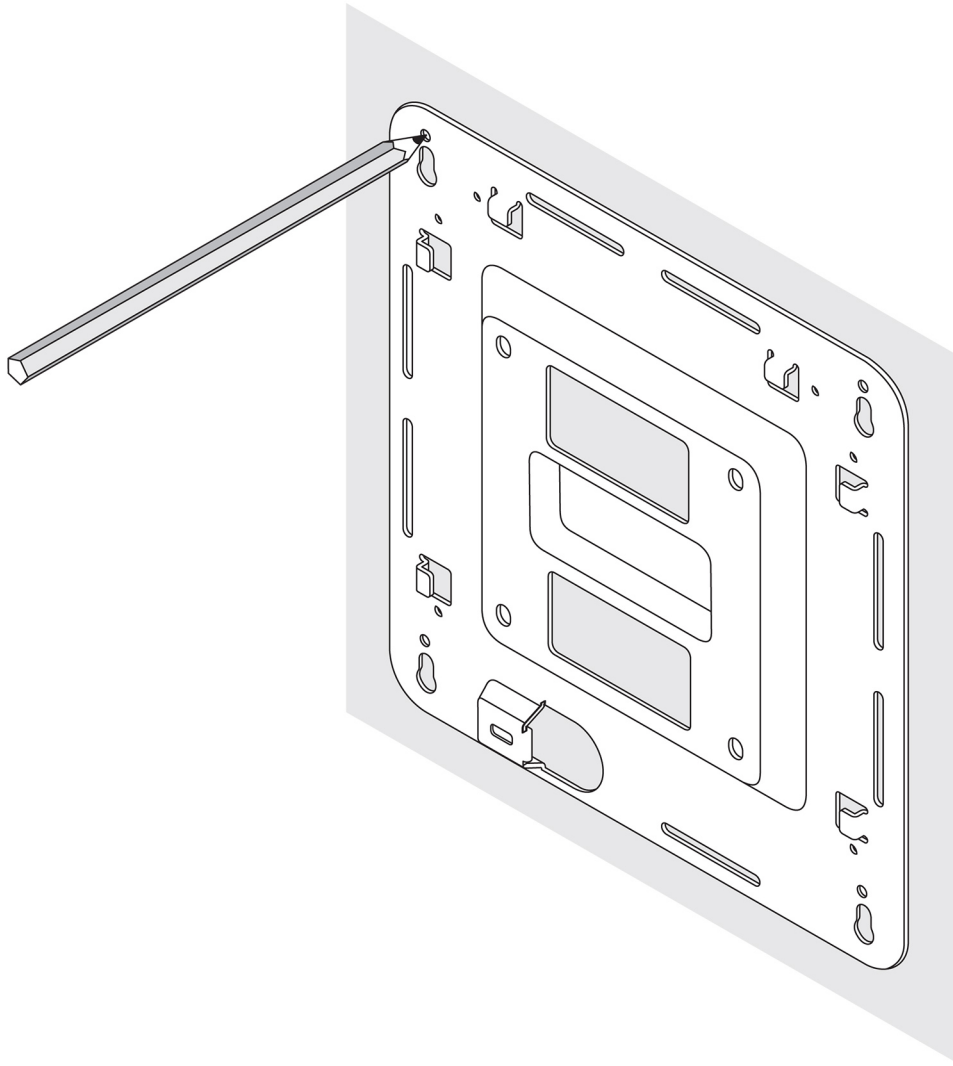

2. Drill four holes in the wall as marked.
3. Insert and tighten four screws (not supplied) to the wall.

 **NOTE: Purchase screws that fit the diameter of the screw holes.**

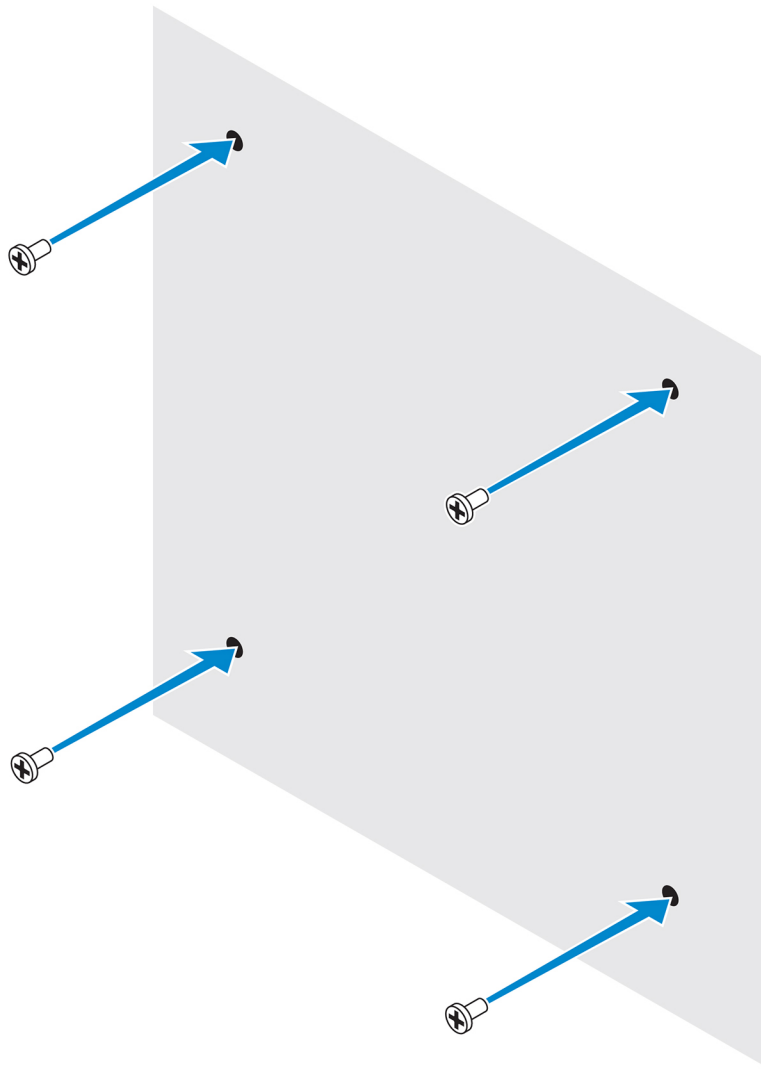

4. Align the screw holes on the standard-mount bracket with the screws on the wall, letting the bracket hang on the screws.

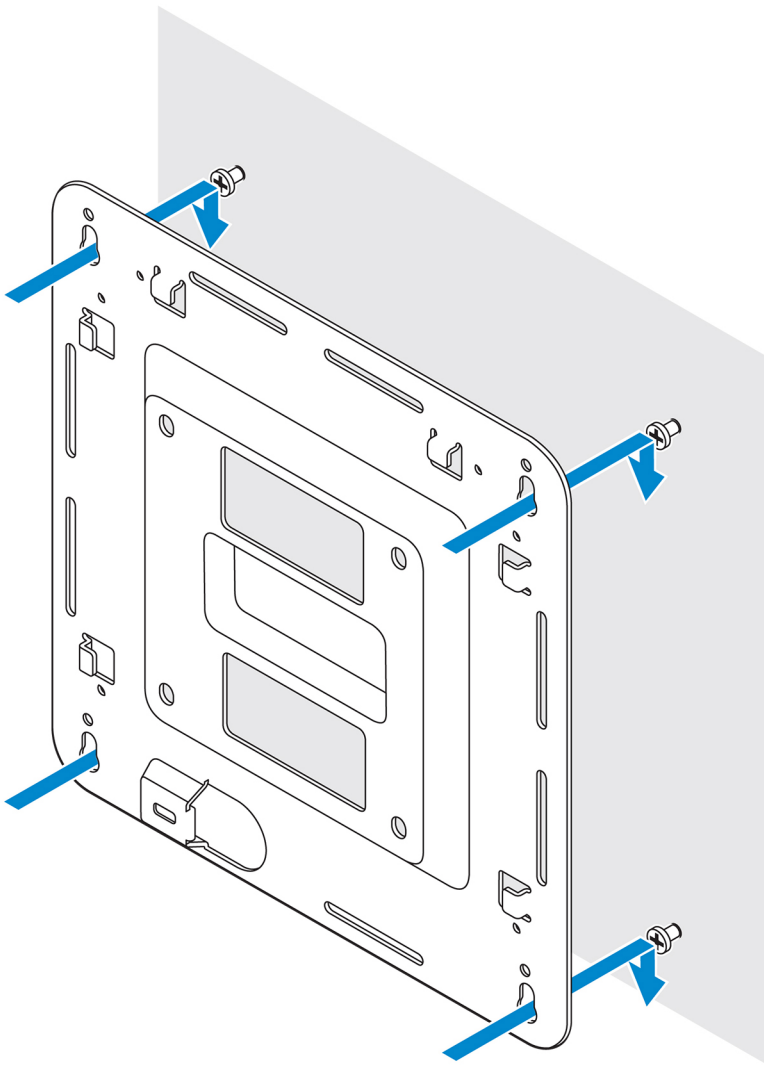

5. Tighten the screws to secure the assembly to the wall.

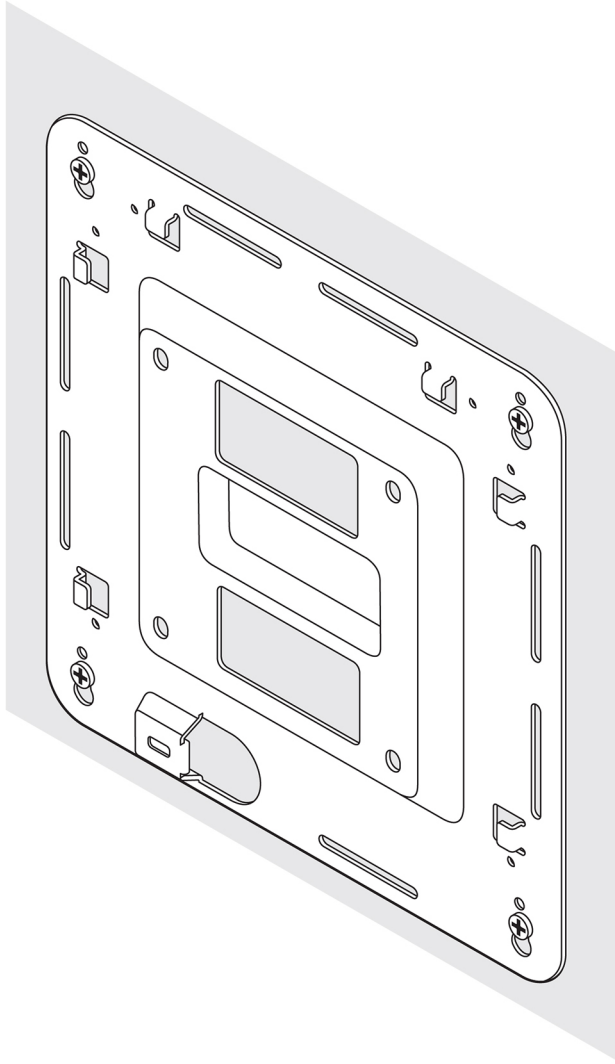

6. Align the screw holes on the DIN-rail bracket with the screw holes at the back of the Edge Gateway.
7. Place the two M4x5 screws on the DIN-rail bracket and secure it to the Edge Gateway.

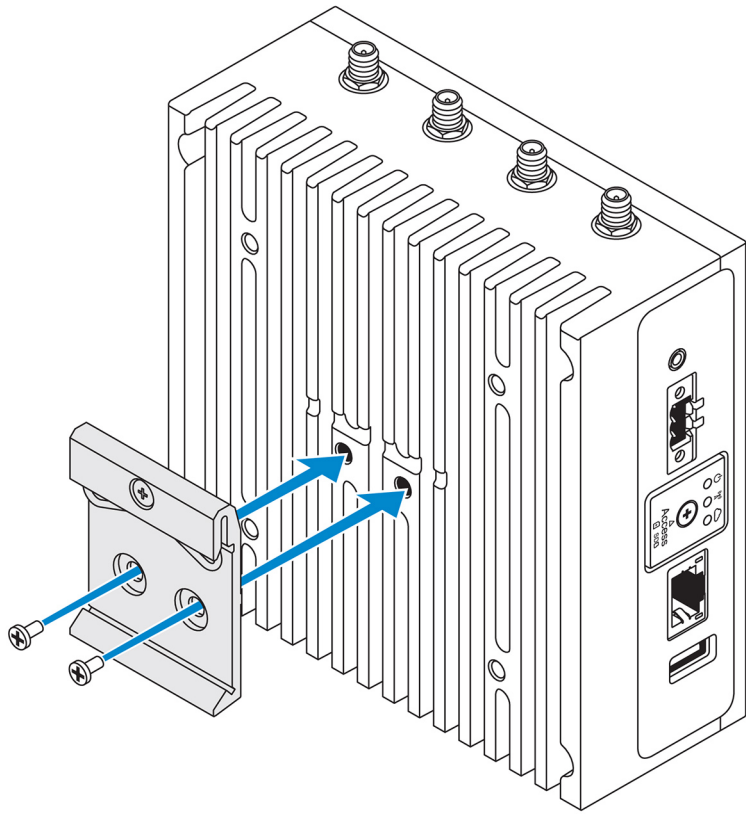

8. Place the Edge Gateway on the standard mount at an angle, and then pull the Edge Gateway down to compress the springs at the top of the DIN-rail bracket.

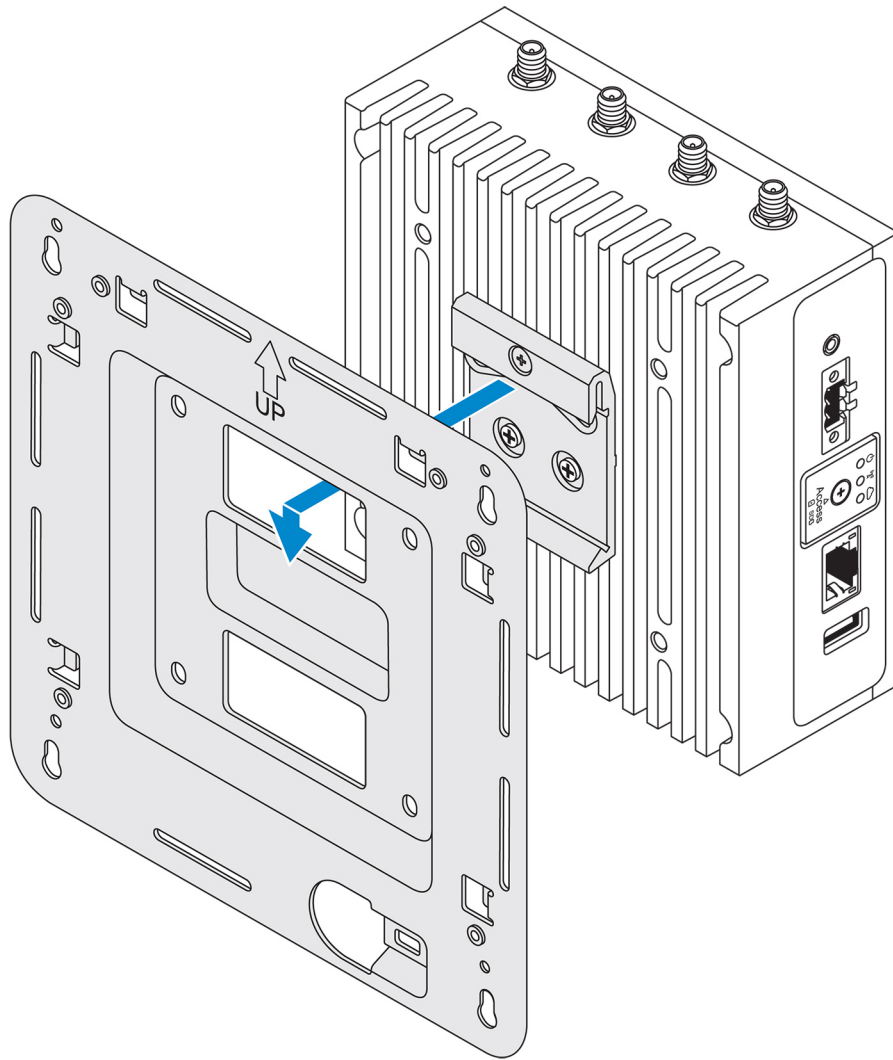

9. Push the Edge Gateway towards the DIN-rail to secure it on the standard-mount bracket.

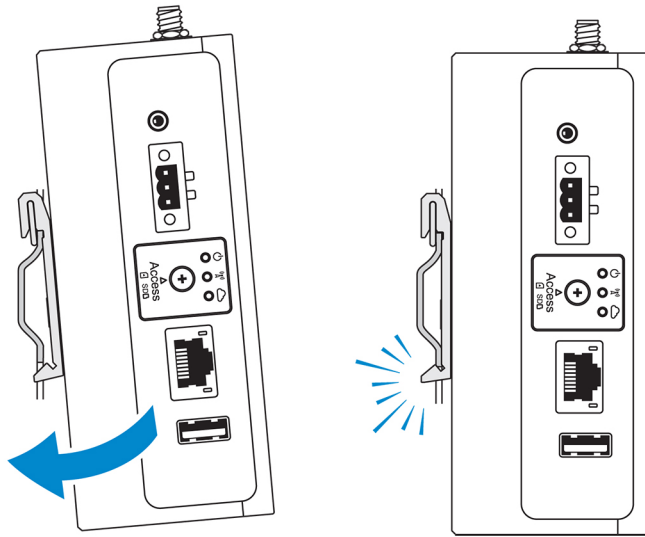

 **NOTE:** For more information about demounting the DIN-rail, see [Demounting DIN rail](#).

Attaching the cable control bars to the standard-mount bracket

1. Mount the Edge Gateway on the wall using the [standard-mount bracket](#) or [quick-mount bracket](#).
2. Place the cable control bar on the mounting bracket and secure it to the notch.

 **CAUTION:** Use the top cable control bar only with coaxial cable connections. Do not use with antennas.

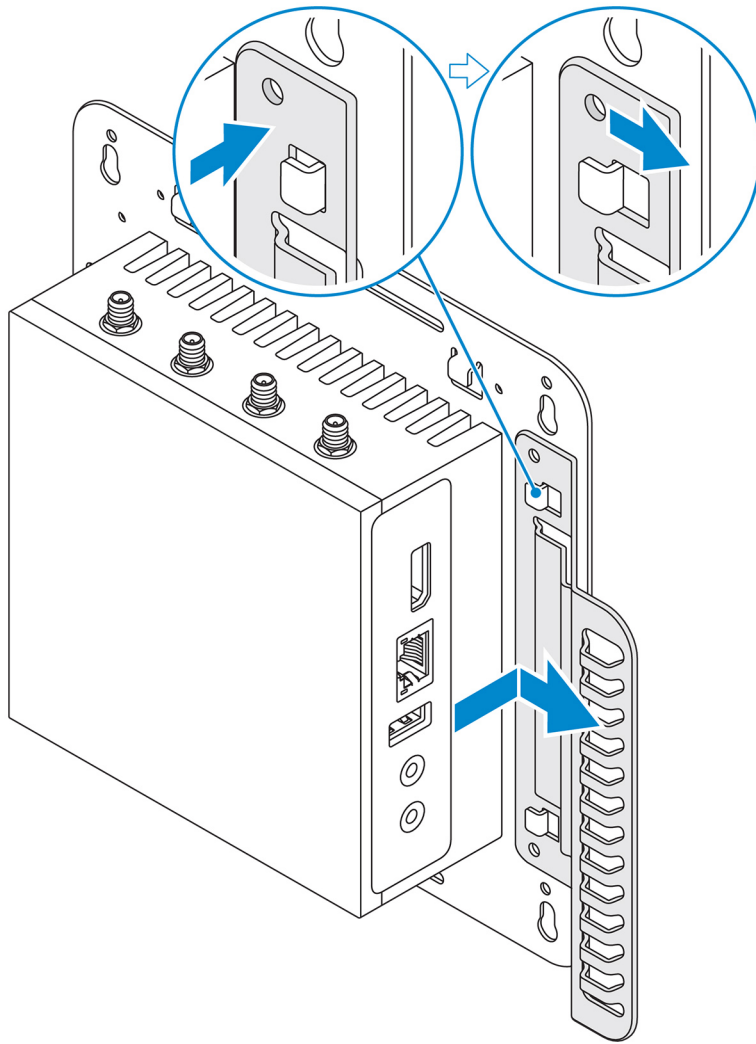

3. Align the screw holes on the cable control bar with the screw holes on the mounting bracket.
4. Tighten the six M3x3.5 mm screws that secure the cable control bar to the mounting bracket.

 **NOTE: Torque the screws at 5±0.5 kilograms-centimeter (11.02±1.1 pounds-inch).**

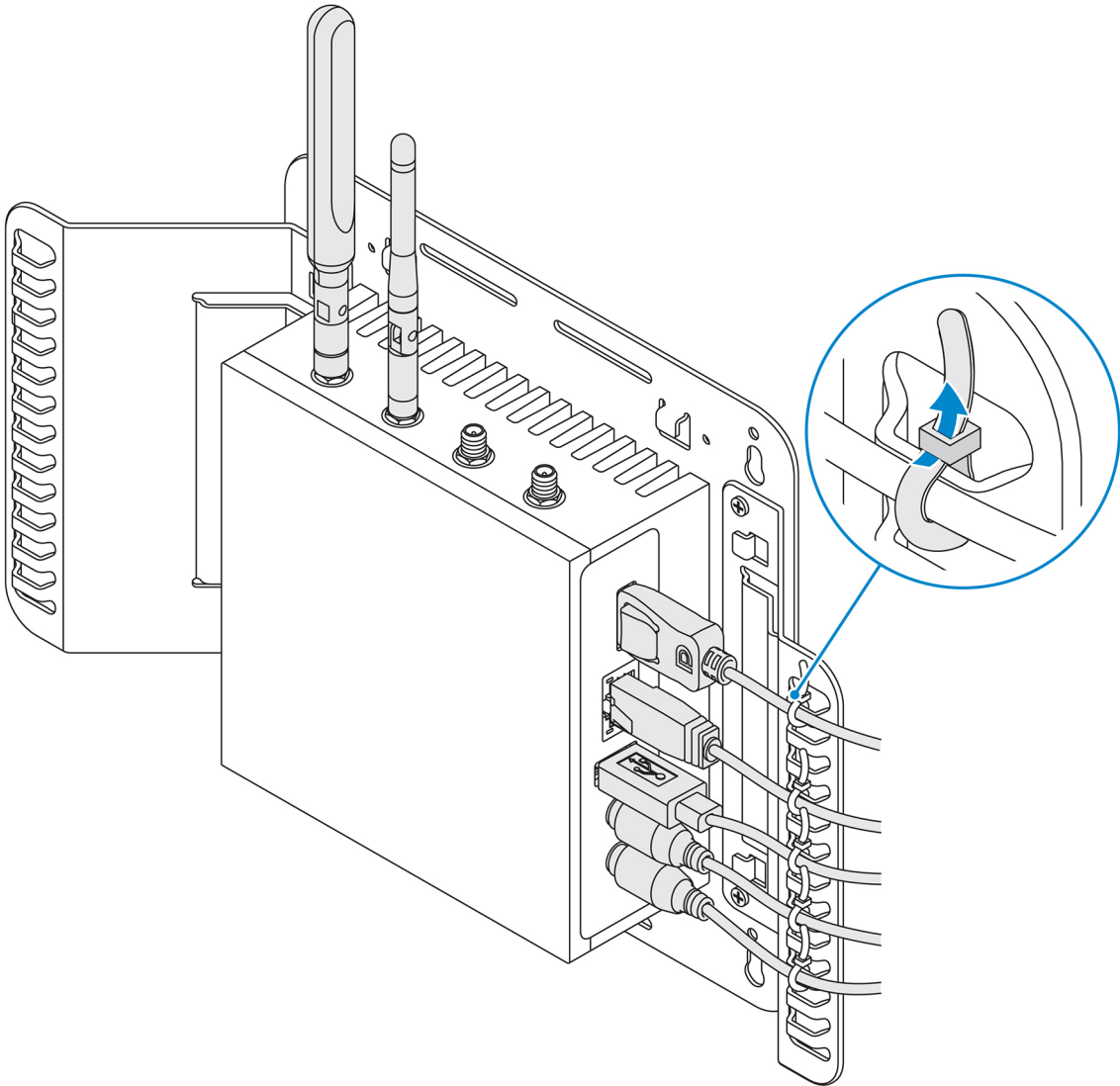

5. Connect the cables to the Edge Gateway.
6. Loop the cable lock (not supplied) to secure each cable to the cable control bar.

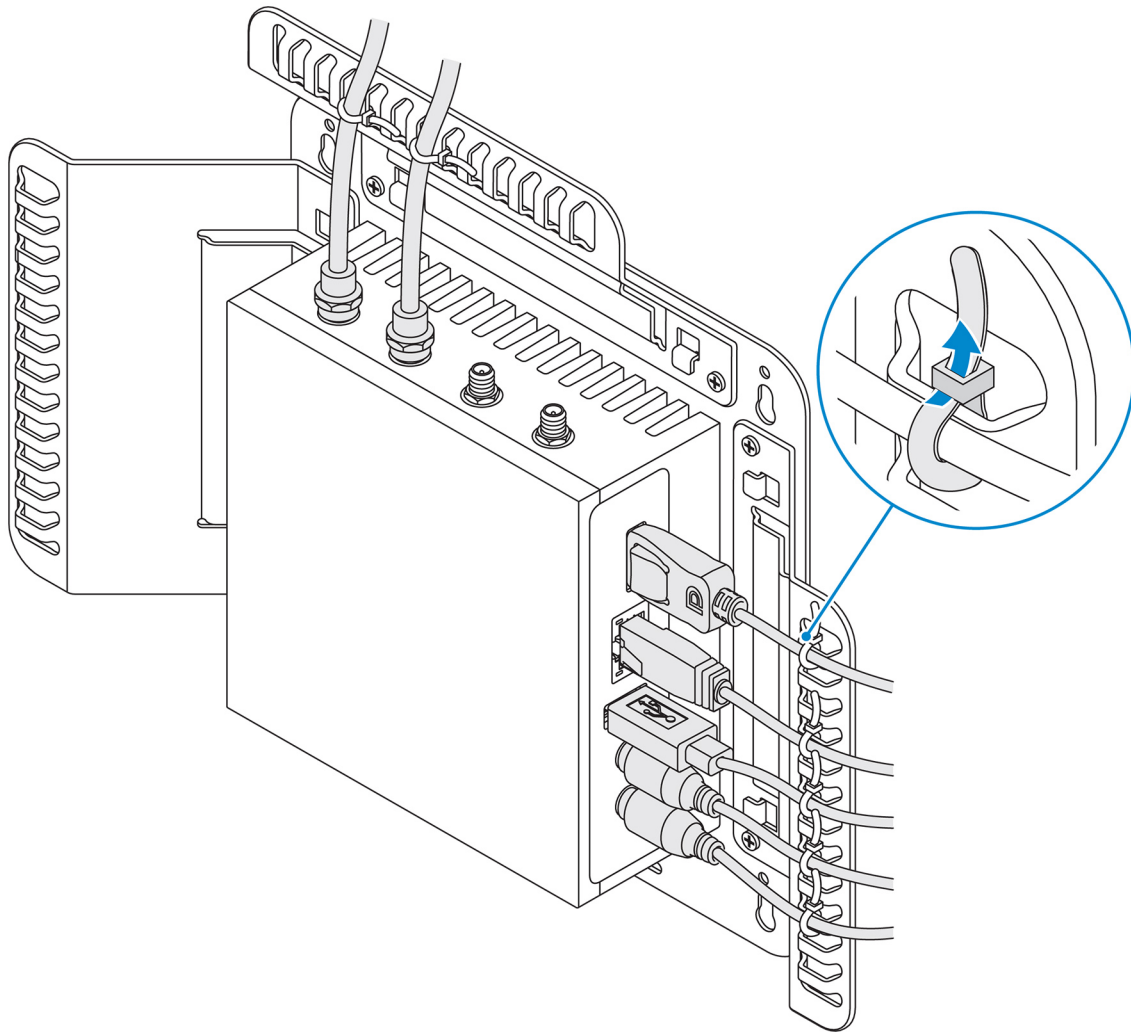

Mounting the Edge Gateway on a DIN rail using the DIN-rail bracket

 **NOTE:** The DIN-rail bracket includes the screws that are required for securing the bracket to the Edge Gateway.

1. Align the screw holes on the DIN-rail bracket with the screw holes at back of the Edge Gateway.
2. Place the two M4x5 screws on the DIN-rail bracket and secure it to the Edge Gateway.

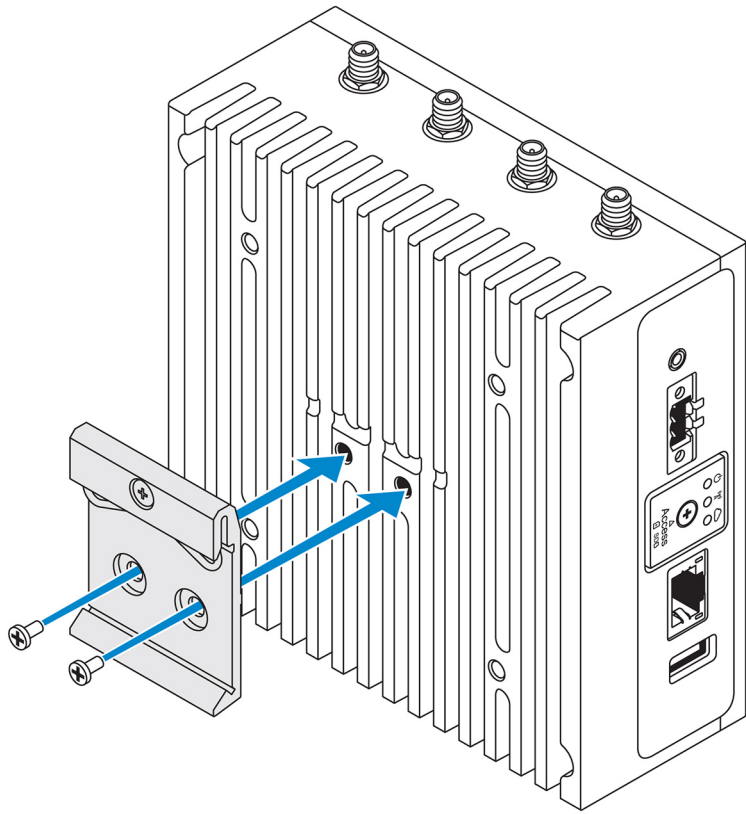

3. Secure the DIN-rail mounting bracket to the Edge Gateway using the two M4x5 screws provided.

 **NOTE: Torque the screws at 8 ± 0.5 kilograms-centimeter (17.64 ± 1.1 pounds-inch) on the DIN-rail mounting bracket.**

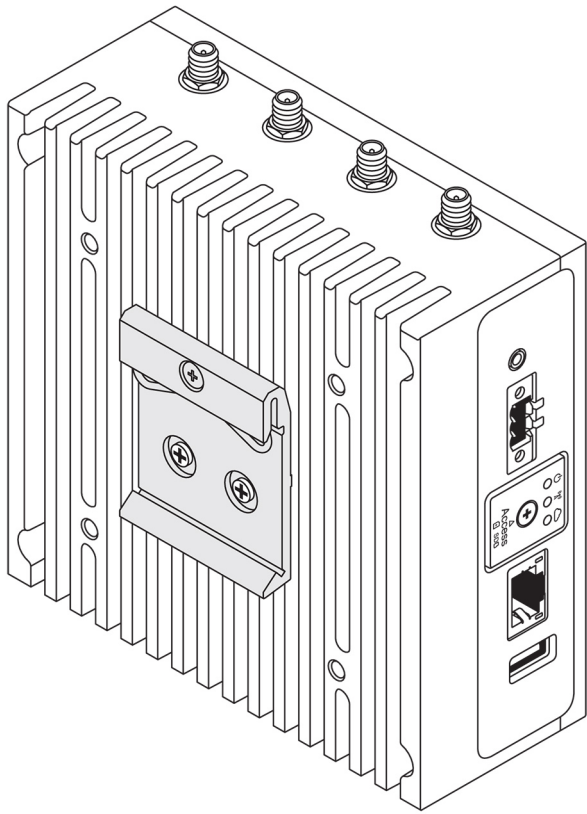

4. Place the Edge Gateway on the DIN rail at an angle, and then pull the Edge Gateway down to compress the springs at the top of the DIN-rail mounting bracket.
5. Push the Edge Gateway towards the DIN-rail to secure the lower clip of the bracket onto the DIN rail.

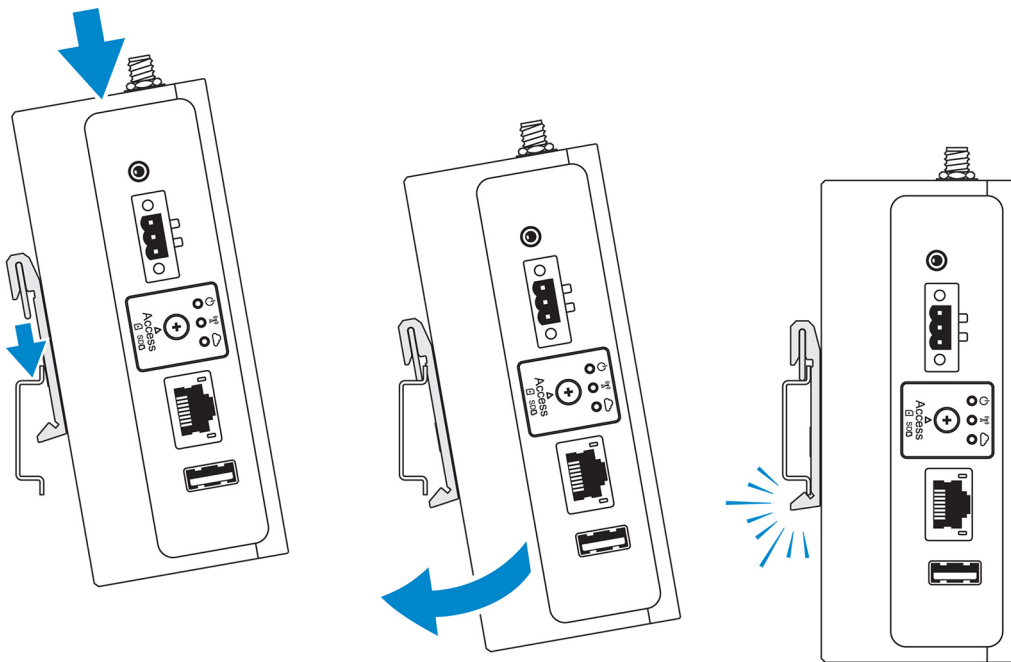

 **NOTE:** For more information about demounting the DIN-rail, see [Demounting DIN rail](#).

Mounting the Edge Gateway using the perpendicular mount

 **NOTE:** The perpendicular mount is designed for mounting in a DIN-rail only.

 **NOTE:** An open space of 63.50 mm (2.50 in) around the Edge Gateway is recommended for optimal air circulation. Ensure that the environmental temperature in which the Edge Gateway is installed does not exceed the operating temperature of the Edge Gateway. For more information about the operating temperature of the Edge Gateway, see the *Edge Gateway Specifications*.

1. Align the screw holes on the perpendicular-mount bracket with the screw holes on the Edge Gateway.

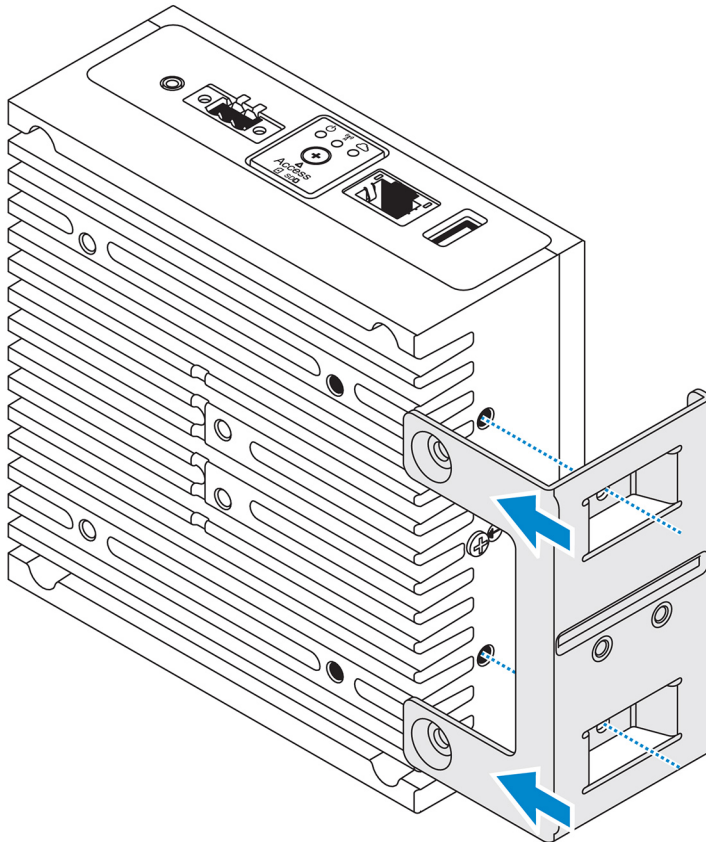

2. Tighten the four M4x7 screws to secure the Edge Gateway to the perpendicular-mount bracket.

 **NOTE:** Torque the screws at 8 ± 0.5 kilograms-centimeter (17.64 ± 1.1 pounds-inch).

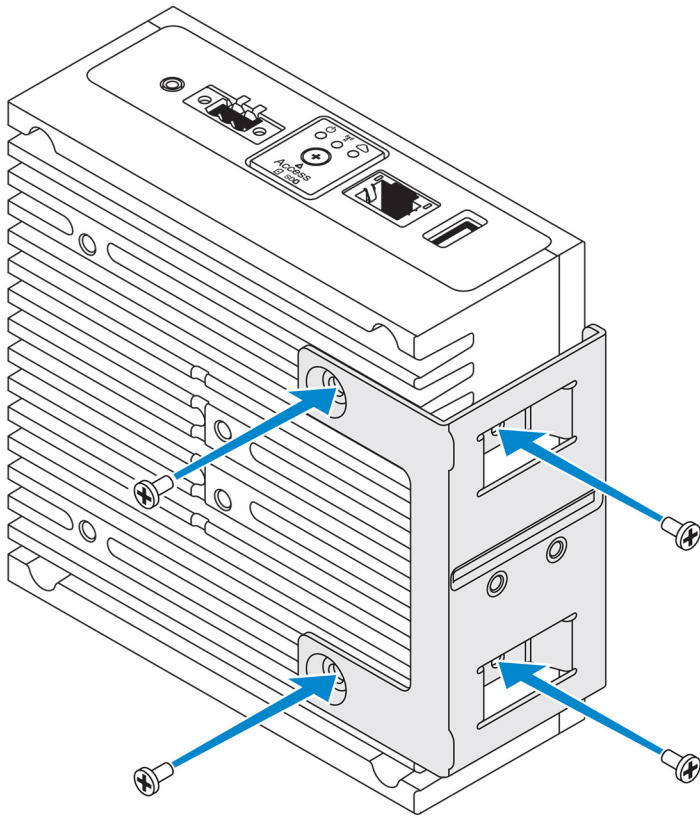

3. Align the screw holes on the DIN-rail mount bracket with the screw holes on the perpendicular-mount bracket, and tighten the two screws.

 **NOTE: Torque the screws at 8 ± 0.5 kilograms-centimeter (17.64 ± 1.1 pounds-inch).**

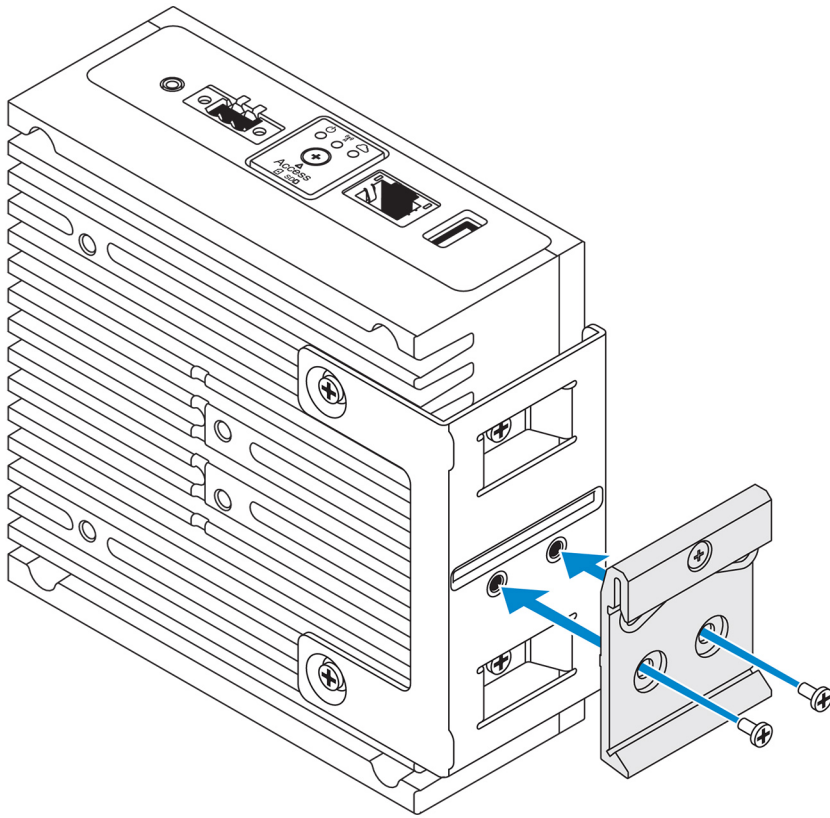

4. Place the Edge Gateway on the DIN rail at an angle and push the Edge Gateway down to compress the springs on the DIN-rail mount brackets.

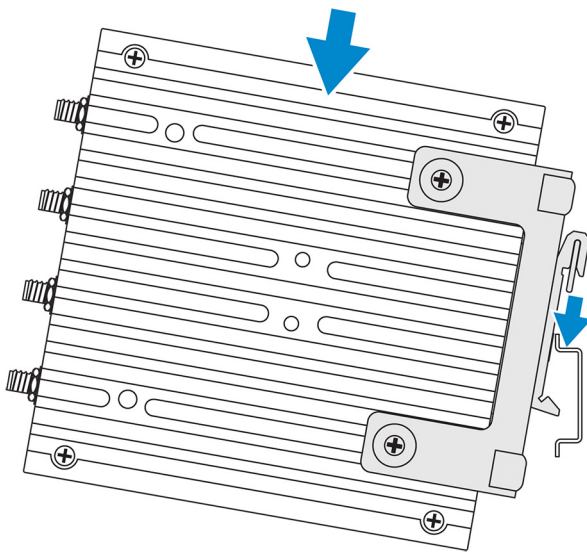

5. Push the Edge Gateway towards the DIN-rail to secure the lower clip of the bracket onto the DIN rail.

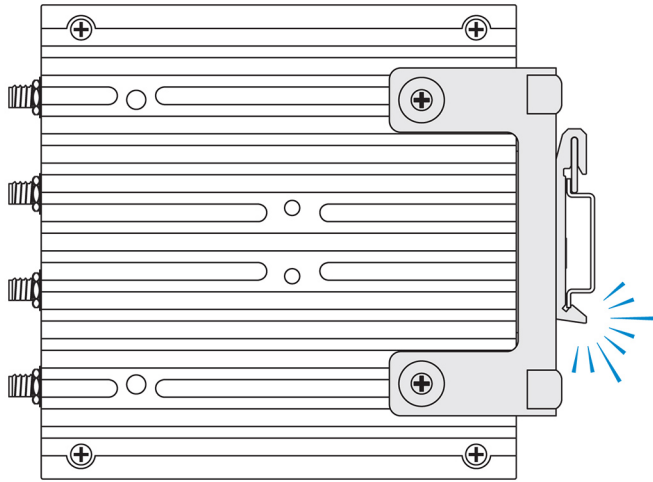

6. Secure the Edge Gateway on the DIN rail.

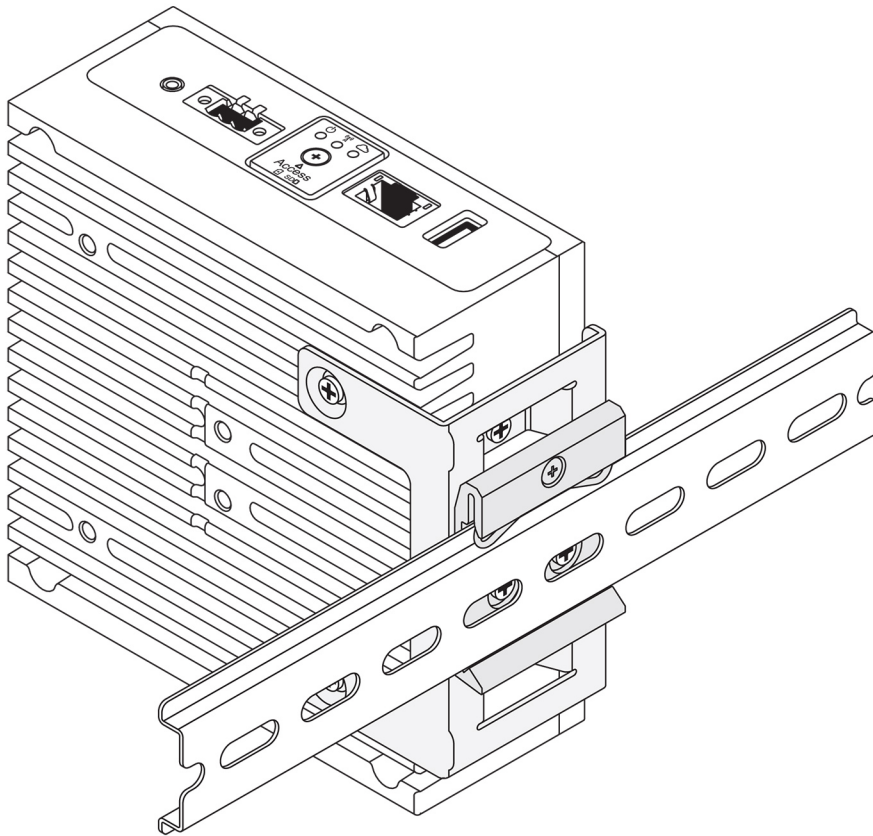

Mounting the Edge Gateway using a VESA mount

The Edge Gateway can be mounted on a standard VESA mount (75 mm x 75 mm).

-  **NOTE:** The VESA mount option is sold separately. For VESA mounting instructions, see the documentation that is shipped with the VESA mount.

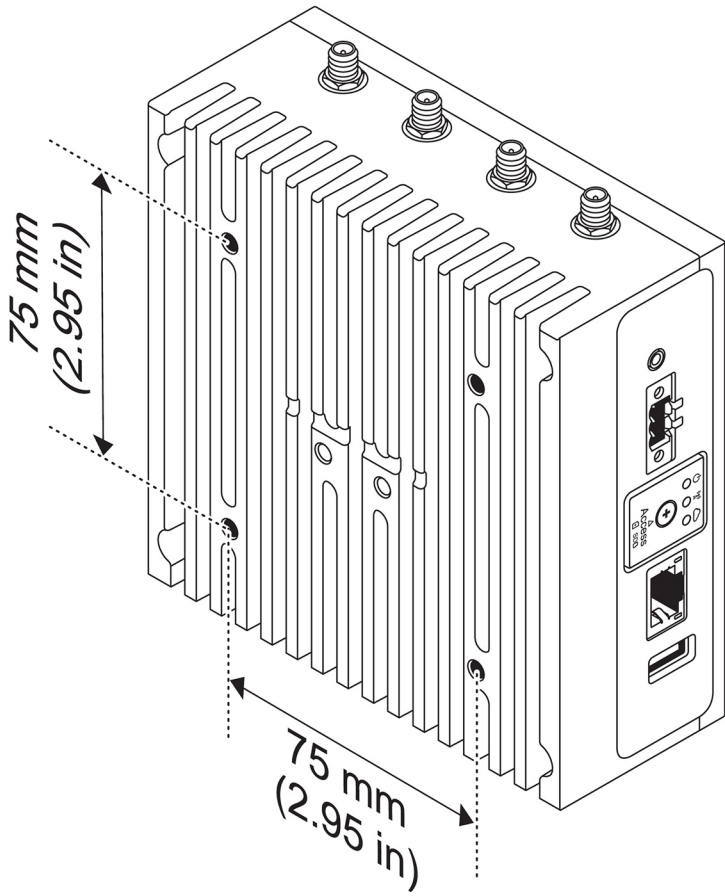

Setting up the ZigBee dongle

CAUTION: Do not connect the ZigBee dongle if the Edge Gateway is installed inside the enclosure.

1. Power off your Edge Gateway.
2. Connect the ZigBee dongle to any external USB port on your Edge Gateway.

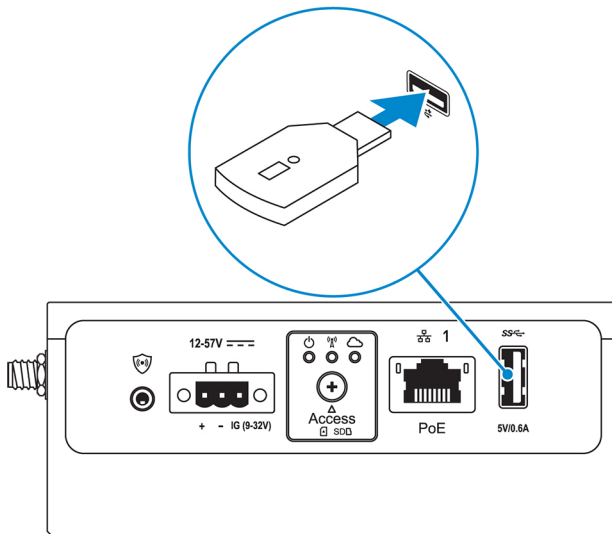

3. Power on your Edge Gateway and complete the setup.

NOTE: For more information about the ZigBee development, see www.silabs.com.

Setting up the operating system

 **CAUTION:** To prevent operating system corruption from sudden power loss, use the operating system to gracefully shut down the Edge Gateway.

The Edge Gateway is shipped with one of the following operating systems:

- Windows 10 IoT Enterprise LTSC 2016
- Ubuntu Core 16

 **NOTE:** For more information about Windows 10 operating system, see msdn.microsoft.com.

 **NOTE:** For more information about the Ubuntu Core 16 operating system, see www.ubuntu.com/desktop/snappy.

Windows 10 IoT Enterprise LTSC 2016

Boot up and login – Direct system configuration

1. Connect a monitor, keyboard and mouse to the Edge Gateway before you login.
2. Power on the Edge Gateway. At the first boot, you will not be prompted to enter login credentials. Subsequent boots will prompt for you to log in.

 **NOTE:** The default user name and password are both `admin`.

Boot up and login—Static IP system configuration

 **NOTE:** To help set up the Edge Gateway remotely, the static IP address of Ethernet port two on the Edge Gateway is set to these values at the factory:

- IP address: 192.168.2.1
- Subnet mask: 255.255.255.0
- DHCP server: Not applicable

You can connect your Edge Gateway to a Windows computer that is on the same subnet using a crossover cable.

1. On the Windows computer, search for **View network connections** in the control panel.
2. In the list of network devices displayed, right-click the Ethernet adaptor that you want to use to connect to the Edge Gateway, then click **Properties**.
3. On the **Networking** tab, click **Internet Protocol Version 4 (TCP/IPv4)** → **Properties**.
4. Select **Use the following IP address**, then enter 192.168.2.x (where x represents the last digit of the IP address, for example, 192.168.2.2).

 **NOTE:** Do not set the IPv4 address to the same IP address as the Edge Gateway. Use an IP address between 192.168.2.2 to 192.168.2.254.

5. Enter the subnet mask 255.255.255.0, then click **OK**.
6. Secure a crossover network cable between Ethernet port two on the Edge Gateway and the configured Ethernet port on the computer.
7. On the Windows computer, launch **Remote Desktop Connection**.
8. Connect to the Edge Gateway using the IP address 192.168.2.1. The default username and password are both `admin`.

Restoring Windows 10 IoT Enterprise LTSB 2016

 **CAUTION: These steps will delete all the data on your Edge Gateway.**

You can restore Windows 10 IoT Enterprise LTSB 2016 by using a USB flash drive.

Prerequisites

Create the recovery USB flash drive. For more information, see [Creating the recovery USB flash drive](#).

Procedure

1. Connect the recovery USB flash drive to the Edge Gateway.
2. Power on the Edge Gateway.

The Edge Gateway will automatically boot from the USB recovery flash drive and restore Windows back to the factory image. Restoration takes about 25 minutes to complete and a confirmation log file is stored on the USB flash drive. Once restoration is complete, the system will power off.

 **NOTE: The confirmation log file is named <service tag>_<date>_<time>.txt**

Windows 10 IOT Enterprise LTSB 2016 basic functions

BIOS update

Download BIOS updates for the Edge Gateway from www.dell.com/support. The download includes an executable file that may be run from the local machine. For more information about updating the BIOS, see [Accessing and updating the BIOS](#).

Watchdog Timer

The Watchdog Timer for Windows 10 IoT Enterprise LTSB 2016 is controlled through the BIOS setting. Enter the BIOS during boot by pressing F2.

The Watchdog Timer is enabled and disabled under the BIOS setting **Watchdog Timer**.

 **NOTE: For more information about BIOS settings on the Edge Gateway, see [Default BIOS settings](#).**

Cloud LED

 **NOTE: To utilize the Cloud LED, download the necessary tools and drivers from www.dell.com/support.**

One unique feature of the Edge Gateway 3000 Series is the *Cloud LED*. Cloud LED enables you to visually inspect the operational status of the Edge Gateway by looking at the display light on the left panel of the Edge Gateway.

To enable this feature, you must expose and program a GPIO register on the Edge Gateway.

Follow these steps to control the Cloud LED on the Edge Gateway:

1. Download the Cloud LED utility from www.dell.com/support.
2. Extract the following files:
 - a. DCSTL64.dll
 - b. DCSTL64.sys
 - c. DCSTL64.inf
 - d. DCSTL64.cat
 - e. CloudLED.exe

 **NOTE: These files must be in the same directory.**

3. Run the **CloudLED.exe** from Command Prompt or PowerShell with administrative rights. Run the following commands:



- CloudLED.exe ON
- CloudLED.exe OFF

TPM support

Windows 10 IoT Enterprise LTSC 2016 supports TPM 2.0. For more information about TPM resources, see technet.microsoft.com/en-us/library/cc749022.

System shutdown and restart

Click **Start** → **Power**, and then click **Restart** or **Shutdown** to restart or shutdown the Edge Gateway, respectively.

LAN and WLAN network configuration

In the **Search** box, type `Settings` and open the **Settings** window. Select **Network & Internet** to configure the network.

Bluetooth configuration

In the **Search** box, type `Settings` and open the **Settings** window. Select **Devices**, and then select **Bluetooth** from the menu on the left panel to configure the network.

WWAN (5815) network configuration

 **NOTE:** Ensure that the micro-SIM card is already activated by your service provider before using it in the Edge Gateway. For more information, see [activate your mobile broadband service](#).

Follow these steps after installing the micro-SIM card:

1. In the **Search** box, type `Settings` and open the **Settings** window.
2. Select **Network & Internet**.
3. Locate the WWAN connection in the Wi-Fi section and select the entry to connect and disconnect from the WWAN adapter.

Ubuntu Core 16

Overview

Ubuntu Core 16 is a Linux OS distribution that is an entirely new mechanism for managing IOT systems and its applications. For more information about Ubuntu Core 16 OS, see

- www.ubuntu.com/cloud/snappy
- www.ubuntu.com/internet-of-things

Prerequisites for setting up Ubuntu Core 16

Infrastructure

An active connection to the internet is needed to update the Ubuntu Core 16 operating system as well as applications (snaps).

Prior knowledge

- Ensure the personnel setting up Ubuntu Core 16 operating system has prior knowledge of the following:
 - Unix/Linux commands
 - Serial communication protocol
 - SSH terminal emulators (for example, PuTTY)
 - Network settings (for example, proxy URL)

Boot up and log in – Direct system configuration

1. Power on the Edge Gateway. The system sets up the operating system automatically and restarts multiple times to apply all the configurations. The system takes approximately one minute to boot to the operating system.

- When prompted, log in using the default credentials. The default user name and password are both `admin`. The default computer name is the service tag.

For example;

```
Ubuntu Core 16 on 127.0.0.1 (tty1)
localhost login: admin
Password: admin
```

Boot up and log in – Static IP system configuration

This allows you to connect your Edge Gateway through a host computer, which must be on the same subnet.

 **NOTE: The static IP address of Ethernet port two on the Edge Gateway is set to these values at the factory:**

- IP address: 192.168.2.1
- Subnet mask: 255.255.255.0
- DHCP server: Not applicable

- On the host computer, configure the Ethernet adaptor that is connected to the Edge Gateway with a static IPv4 address under the same subnet. Set the IPv4 address to 192.168.2.x (where x represents the last digit of the IP address, for example, 192.168.2.2).

 **NOTE: Do not set the IPv4 address to the same IP address as the Edge Gateway. Use an IP address between 192.168.2.2 to 192.168.2.254.**

- Set the subnet mask to 255.255.255.0.

Updating operating system and applications

After enabling the network connections and connecting to the internet, Dell recommends to have the latest OS components and applications installed. To update Ubuntu Core 16, run:

```
admin@localhost:~$ sudo snap refresh
```

Viewing operating system and application versions

Run the command:

```
admin@localhost:~$ sudo uname -a
```

returns

```
Linux ubuntu.localdomain 4.4.30-xenial_generic #1 SMP Mon Nov 14 14:02:48 UTC 2016 x86_64
x86_64 x86_64 GNU/Linux
```

 **NOTE: Check if a newer version of the software is available. For more information on checking for updates, see [Updating operating system and applications](#).**

Additional Ubuntu commands

Basic commands

 **NOTE: For more information about Ubuntu commands, see <https://snapcraft.io/>.**

Table 8. Basic commands

Action	Ubuntu Core 16
Viewing system attributes	<code>#sudo snap version</code>
Updating the image to the latest release	<code>#sudo snap update</code>
Viewing a list of all the snaps that are currently installed	<code>#sudo snap find</code>
Viewing a set and attribute to a snap	<code>#sudo snap set <snap> <attribute>=<value></code>
Querying attributes from a snap	<code>#sudo snap get <snap></code>



Action	Ubuntu Core 16
Rebooting the system	<p>Run the command:</p> <pre>admin@localhost:~\$ sudo reboot</pre> <p>returns:</p> <pre>System reboot successfully</pre>
Shutting down the system	<p>Run the command:</p> <pre>admin@localhost:~\$ sudo poweroff</pre> <p>The system shuts down successfully.</p>
Add a new user if libnss-extrausers is pre-installed	<pre>\$sudo adduser --extrausers testuser</pre>
Change a user's password	<pre>\$sudo passwd <user-name></pre>
Re-mount the Ubuntu Snappy 16 root-file system as read only	<pre>Snappy 16 rootfs is Read-Only</pre>
Accessing the built-in help	<pre>admin@localhost:~\$ sudo snap --help</pre>
Listing the installed snaps	<pre>admin@localhost:~\$ sudo snap list</pre>
Updating the system name	<pre>admin@localhost:~\$ network-manager.nmcli general hostname <NAME></pre>
Changing the time zone	<p>When the system arrives from the factory, the operating system is usually set to the UTC time zone.</p> <p>To change the time zone to your location, run the command:</p> <pre>admin@localhost:~\$ sudo timedatectl --help</pre>
Root-user credential	<p>Run the command:</p> <pre>admin@localhost:~\$ sudo su -</pre> <p>Returns:</p> <pre>\$ admin@localhost:~# sudo su - \$ root@localhost:~#</pre>
Identifying the System Service Tag	<p>Run the command:</p> <pre>admin@localhost:~\$ cat /sys/class/dmi/id/product_serial</pre> <p>The system tag is printed.</p>
Identifying the system vendor	<p>Run the command:</p> <pre>admin@localhost:~\$ cat /sys/class/dmi/id/board_vendor</pre> <p>returns</p> <pre>Dell Inc.</pre> <p>The system tag is printed.</p>

Ubuntu Network Manager

Network-Manager is a native Ubuntu Snappy connection manager. The application can be used to configure the Edge Gateway so that it's automatically-detected and connected to the network. The application can be used to configure multiple network devices. A command-line utility **nmcli** is included with Network-Manager to support non-graphical user interface configurations.

 **NOTE:** For more information about Network Manager, see <https://wiki.archlinux.org/index.php/NetworkManager>

Connecting through WWAN

 **NOTE:** For more information on configuring and connecting through WWAN, see <https://docs.ubuntu.com/core/en/stacks/network/network-manager/docs/configure-cellular-connections>.

1. Check if a modem is present and identify the modem index number.

```
$ sudo modem-manager.mmcli -L
```

2. Check the modem status and identify the primary port.

```
$ sudo modem-manager.mmcli -m <x>
```

 **NOTE:** <x> refers to the modem index number. Replace <x> with the modem index number after running the command at step 1.

3. Create a profile.

```
$ sudo network-manager.nmcli c add con-name test type gsm ifname <primary port> apn internet
```

 **NOTE:** Depending on the return results from step 2, replace <primary port > after ifname with the actual primary port name.

4. Check the WWAN status.

```
$ network-manager.nmcli r wwan
```

5. Turn on WWAN.

```
$ sudo network-manager.nmcli r wwan on
```

6. Find wwan0 in the interface list.

```
$ ifconfig -a
```

7. Enable the connection profile.

```
$ sudo network-manager.nmcli c up test
```

8. Check the **Network Manager** status.

```
$ network-manager.nmcli d
```

9. Disable the connection profile.

```
$ sudo network-manager.nmcli c down test
```

10. Check the **Network Manager** status.

```
$ network-manager.nmcli d
```

Connecting through WLAN

1. Show a list of network interfaces like **eth0**, **eth1**, **wlan0**, **mlan0**, and so on.

```
$ network-manager.nmcli d
```

2. Show a list of network interfaces like **eth0**, **eth1**, **wlan0**, **mlan0**, and so on.

```
$ network-manager.nmcli d
```

3. Show a list of available wireless access points.

```
$ network-manager.nmcli device wifi list
```

4. Wireless connection with nmcli: Run the following commands and replace \$SSID, \$PSK, and \$WIFI_INTERFACE with the variables for your environment.

- Connect:

```
$ sudo network-manager.nmcli dev wifi connect $SSID password $PSK ifname $WIFI_INTERFACE
```

- Disconnect:

```
$ sudo network-manager.nmcli dev disconnect $WIFI_INTERFACE
```

Connecting through software-enabled Access Point (SoftAP)

This feature depends on the wireless module and its associated driver to function as a wireless-access point.





NOTE: For more information on SoftAP, see <https://docs.ubuntu.com/core/en/stacks/network/wifi-ap/docs/index>.

1. Login to Ubuntu Snappy. Make sure that the system is connected to the internet.

2. Run the command to find the application from the Ubuntu Snappy Store.

```
#sudo snap search wifi-ap
```

3. Run the command to install the application.

```
#sudo snap install wifi-ap
```

4. After snap is installed, run the command to check the status.

```
$ wifi-ap.status
```

5. Run the command to enable the access point and restart the service.

```
$ wifi-ap.config set disabled=false
```

The WiFi-AP default SSID **Ubuntu** is now visible to clients.

To secure the WiFi access point with WPA 2 personal, change the following configuration items.

```
$ wifi-ap.config set wifi.security=wpa2 wifi.security-passphrase=Test1234
```

The command enables WPA2 security with the passphrase set to Test1234.

Connecting through Bluetooth

This feature allows the system to connect to Bluetooth devices such as a Bluetooth keyboard.

1. Run the command to start **bluetoothctl** console.

```
#bluetoothctl -a
```

The **bluetoothctl** console opens.

2. Run the command to power on the Bluetooth device.

```
$power on
```

3. Register the agent for the keyboard:

```
$agent KeyboardOnly  
$default-agent
```

4. Run the command to put the Bluetooth controller in pair-able mode.

```
$pairable on
```

5. Run the command to scan for nearby Bluetooth devices.

```
$scan on
```

6. Run the command to stop scanning after the Bluetooth keyboard is found.

```
$scan off
```

7. Run the command to pair the Bluetooth keyboard.

```
$pair <MAC address of Bluetooth keyboard>
```

8. Enter the PIN code on the Bluetooth keyboard, if needed.

9. Run the command to trust the Bluetooth keyboard.

```
$trust <MAC address of Bluetooth keyboard>
```

10. Run the command to connect the to the Bluetooth keyboard.

```
$connect <MAC address of Bluetooth keyboard>
```

11. To quit the **bluetoothctl** console.

```
$quit
```

Switching between WLAN and Bluetooth modes

1. Unload the WLAN/BT driver.

```
$ modprobe -r ven_rsi_sdio
```

2. Adjust the mode in `/etc/modprobe.d/rs9113.conf`

3. Reload the WLAN/BT driver.

```
$ modprobe ven_rsi_sdio
```

4. Verify the operation mode. Refer to the table for operating mode values.

```
$ cat /sys/module/ven_rsi_sdio/parameters/dev_oper_mode
```

Table 9. Operating-mode values for WLAN and Bluetooth

Operating mode value	WiFi station	BT/BLE modes supported	softAP	Clients supported by softAP
1	X	N/A		N/A
1		N/A	X	32
13	X	Dual (BT classic and BTLE)		N/A
14		Dual (BT classic and BTLE)	X	4
5	X	BT Classic		N/A
6		BT Classic	X	32

Bluetooth Serial Port Profile (SPP)

Assumptions for MAC addresses of each BT adapter:

- BT MAC(MYCLIENT): XX:XX:XX:XX:XX:XX
- BT MAC(MYSERVER): YY:YY:YY:YY:YY:YY

1. Pre-requirements (for Debian-only, not required on Ubuntu Core OS).

```
sudo apt-get install bluez bluez-tools
```

2. Prepare to pair MYSERVER and MYCLIENT

```
$ sudo bluez.bluetoothctl -a
[bluetoothctl]# power on
[bluetooth]# discoverable on
[bluetooth]# scan on
[NEW] Device XX:XX:XX:XX:XX:XX MYCLIENT
[bluetooth]# scan off
```

3. Pair with each other. As of Bluetooth v2.1, Secure Simple Pairing is a requirement, and offers three methods of pairing devices, which are applicable on the Dell Gateway 3000 series:

- Just Works
- Numeric Comparison
- Passkey Entry

 **NOTE:** For more information about bluetooth pairing, see <https://blog.bluetooth.com/bluetooth-pairing-part-4>.

```
[bluetooth]# agent on
[bluetooth]# default-agent
[bluetooth]# pairable on
[bluetooth]# pair XX:XX:XX:XX:XX:XX <MAC Address of Device to Pair>
[bluetooth]# connect XX:XX:XX:XX:XX:XX [CHG] Device XX:XX:XX:XX:XX:XX Connected: yes
[bluetooth]# exit
```

4. Configure SPP.

Server Device

```
$ bluez.sdptool add --channel=22 SP
$ ./rfcomm -r listen /dev/rfcomm0 22
Waiting for connection on channel 22
```



```
Connection from XX:XX:XX:XX:XX:XX to /dev/rfcomm0 <These lines will be seen when client comes>
Press CTRL-C for hangup
```

Then, create a new instance of terminal to screen the data over bluetooth serial.

```
$ cat /dev/rfcomm0
```

Client Device

```
$ bluez.sdptool add --channel=22 SP
$ ./rfcomm -r connect /dev/rfcomm0 YY:YY:YY:YY:YY:YY 22
```

Then, create a new instance of terminal to send data, for example, a new instance of ssh.

```
$ echo "test" > /dev/rfcomm0
```

 **NOTE: The rfcomm command is not available in this command. If required, you can copy the binary to the Edge Gateway from an AMD64-based system running Ubuntu 16.04 or above.**

Security

Trusted Platform Module (TPM)

 **NOTE: For more information about the TPM, see <https://developer.ubuntu.com/en/snappy/guides/security-whitepaper/>.**

TPM is only supported on devices that have TPM hardware installed on products with Snappy-enhanced security support. The TPM on/off setting is configurable in the BIOS and manageable in the operating system.

If TPM is turned off, the device node (/dev/tpm0) does not exist.

```
(plano)ubuntu@localhost:~$ ls /dev/tpm0
ls: cannot access /dev/tpm0: No such file or directory
```

If TPM is turned on, the device node (/dev/tpm0) exists.

```
(plano)ubuntu@localhost:~$ ls /dev/tpm0
/dev/tpm0
```

Watchdog Timer (WDT)

 **NOTE: For more information about Watchdog Timer (WDT) commands, see www.sat.dundee.ac.uk/~psc/watchdog/Linux-Watchdog.html.**

Dell recommends that you enable the WDT by default to activate the fail-safe circuitry. Snappy, a WDT-compatible operating system, provides the capability to detect and recover the system from malfunctions or unexpected crashes.

To check daemon status, run the command:

```
admin@localhost:$ systemctl show | grep -i watchdog
```

Returns:

```
RuntimeWatchdogUSec=1min
ShutdownWatchdogUSec=10min
```

 **NOTE: The default value is 10. The actual value should be greater than 0.**

To configure WDT, run the command:

```
admin@localhost:$ sudo vi /etc/systemd/system.conf.d/watchdog.conf
```

Cloud LED On/Off

1. To export Cloud LED PIN, run the command:

```
#sudo su -  
#echo 346 > /sys/class/gpio/export  
#echo out > /sys/class/gpio/gpio346/direction
```

2. To turn on Cloud LED, run the command:

```
#echo 1 > /sys/class/gpio/gpio346/value
```

or

To turn off Cloud LED, run the command:

```
#echo 0 > /sys/class/gpio/gpio346/value
```

Global Positioning Systems (GPS)

 **NOTE:** For more information about GPS configurations, see <http://locationd.readthedocs.io/en/latest/intro.html>.

National Marine Electronics Association (NMEA) data is supported if the GPS module is present in the system. In the operating system, the location service is a central hub for multiplexing access to positioning subsystems available through hardware and software. It provides a client API offering positioning capabilities to applications and other system components..

To retrieve NMEA streaming data:

- Device node for NMEA streaming: Edge Gateway 3001/3003

```
$ cat /dev/ttyS4
```

To access location service:

```
$ sudo locationd.monitor  
Enabled position/heading/velocity updates...  
Update(Position(lat: 26.9511 deg, lon: 155.087 deg, alt: n/a, hor.acc.: n/a, ver.acc.: n/  
a),  
1489044234694526189)  
Update(0.552 m s-1, 1489044234695698701)  
Update(Position(lat: 26.9477 deg, lon: 155.098 deg, alt: n/a, hor.acc.: n/a, ver.acc.: n/  
a), 1489044234718316599)
```

Snappy auto update/Autopilot

Snappy auto update is a feature which runs in the background, ensuring that your software always up-to-date. We recommend that you enable the feature by default. The settings can be adjusted in the Ubuntu Core.

 **NOTE:** For more information automatic updates, see <https://docs.ubuntu.com/core/en/reference/automatic-refreshes>.

Accessing Snappy Store/Snapweb

1. Enter `ip_address:4200` in a browser.



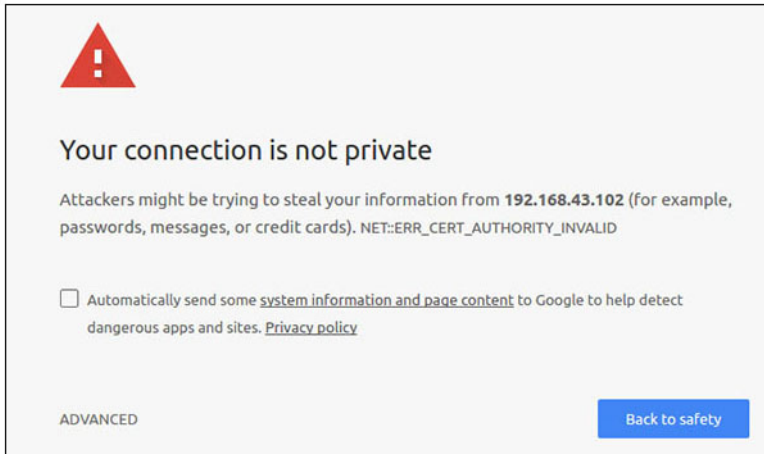

2. Select Advanced, then select proceed to the ip_address (unsafe).
3. Using the default login of 'admin', keeping the password blank, open Terminal and ssh remote login

```
lo@lo-latitude-E7470:~$ ssh admin@10.101.46.209
admin@10.101.46.209's password:
```

4. While running `sudo snapweb.generate-token`, copy the token.

```
lo@lo-latitude-E7470:~$ ssh admin@10.101.46.209
admin@10.101.46.209's password:
Welcome to Ubuntu 16.04.1 LTS (GNU/Linux 4.4.0-45-generic x86_64)
```

```
* Documentation: https://help.ubuntu.com
* Management:   https://landscape.canonical.com
* Support:      https://ubuntu.com/advantage
Welcome to Snappy Ubuntu Core, a transactionally updated Ubuntu.

* See https://ubuntu.com/snappy
```

It's a brave new world here in Snappy Ubuntu Core! This machine does not use apt-get or deb packages. Please see 'snap --hwlp' for app installation and transactional updates.

```
Last login: Tue Nov 01:10:12 2016 from 10.101.46.187
Admin@localhost:~$ sudo snapweb.generate-toen
Snapweb Access Token:
```

GtYaoevIodhTgHDyFWczWtYkEhDYOpX0pf27K62TtTOVooUwRuQ) IgBB7ECznCP

Use the above token in the Snapweb interface to be granted access.
admin@localhost:~\$

5. Paste the token on the web page and click Submit.

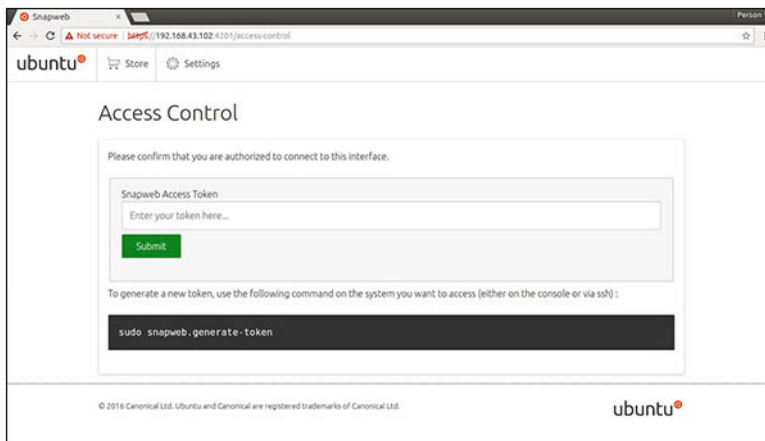

You can now access the snapweb.

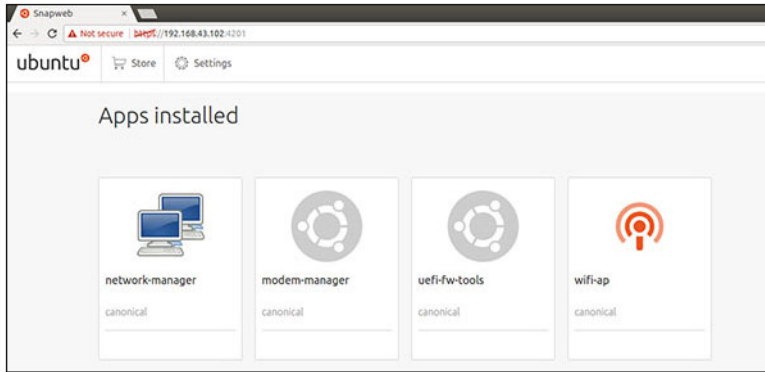

Sensors

The sensors on the Edge Gateway provide measurements on pressure, relative humidity and temperature, and motion.

Table 10. Sensor types

Relative humidity and temperature sensor	ST Micro HTS221
Motion sensor—Accelerometer	ST Micro LNG2DMTR
Pressure sensor	ST Micro LPS22HB

Retrieve the raw data from the sensors by running the following commands. Then, apply the formula in the table to convert the data collected into measurements such as relative humidity and temperature.

Retrieving raw data from sensors

- To query sensor devices, run the command.

```
$ cat /sys/bus/iio/devices/iio:device*/name
```

```
hts221 <-- device0, Humidity and temp.
```

```
lng2dm_accel <-- device1, G-sensor
```

```
lps22hb <-- device2, Pressure
```

- To retrieve data from the humidity and temperature sensor, run the command.

```
$ cat in_humidityrelative_offset  
$ cat in_humidityrelative_raw  
$ cat in_humidityrelative_scale  
$ cat in_temp_offset  
$ cat in_temp_raw  
$ cat in_temp_scale
```

- To retrieve data from the motion sensor, run the command.

```
$ cat in_accel_scale_available  
$ cat in_accel_*_scale  
$ cat in_accel*_raw
```

- To retrieve data from the pressure sensor, run the command.

```
$ cat in_pressure_raw  
$ cat in_pressure_scale
```

Converting raw data for use

Apply the formula in the table to convert the raw data collected into usable measurements.



Configure hibernate state–S4

```
$ sudo systemctl hibernate
```

Rebooting or power off

To reboot the system

```
$ sudo reboot
```

To power off

```
$ sudo poweroff
```

Configuring system wake-up from LAN or WLAN

1. Enable **Wake on LAN** in the BIOS program. For more information on accessing the BIOS program, see [Accessing BIOS settings](#)
2. Connect the system to a wireless network.

```
$ sudo network-manager.nmcli dev wifi connect $SSID password $PSK ifname wlan0
```

3. Enable **Wake on LAN**.

```
$ sudo iw phy0 wowlan enable magic-packet
```

4. Recheck the support status.

```
$ sudo iw phy phy0 wowlan show
```

5. Make sure wlan0 is up and running with IP address.

6. Perform sleep.

```
$ sudo systemctl sleep
```

Or, perform hibernation.

```
$ sudo systemctl hibernate
```

7. Use another system to wake from wlan (Supported tools: wakeonlan, and etherwake).

```
$ sudo wakeonlan MAC
```

```
$ sudo etherwake MAC
```

Restoring Ubuntu Core 16

When the operating system is restored to the factory image, all data on the system is deleted. You can restore Ubuntu Core 16 operating system to the factory image using one of the following methods:

- Restore Ubuntu Core 16 from USB flash drive
- Restore Ubuntu Core 16 from the recovery partition on the Edge Gateway
 - [Option 1: Restoring from the operating system](#)
 - [Option 2: Restoring during system POST](#)
 - [Option 3: Restoring from boot menu \(Edge Gateway 3003 only\)](#)

Option 1: Restoring from the operating system

 **CAUTION: These steps will delete all the data on your Edge Gateway**

1. Connect the Edge Gateway remotely or through a KVM session.
2. Log in to the operating system.
3. Run the following command to trigger native eMMC recovery partition:

```
$ sudo efibootmgr -n $(efibootmgr | grep "factory_restore" | sed 's/Boot//g' | sed 's/[^0-9A-B]*//g') ; reboot
```



Option 2: Restoring during system POST

 **CAUTION: These steps delete all the data on your Edge Gateway.**

1. Connect a USB keyboard to the Edge Gateway.
2. Power on the Edge Gateway.
The Power LED turns solid green while the Cloud LED is off.
3. During the first 20 seconds after applying power, press `Ctrl+F` repeatedly to trigger the operating system recovery.
4. When the Cloud LED starts blinking green, continue with one of these options:

 **NOTE: If the Cloud LED does not start blinking after 50 seconds, power off the Edge Gateway and repeat Steps 2 and 3.**

Table 15. Start or cancel restoration during system POST

To start restoration

- Press `y`, then press `Enter`.

The Cloud LED changes to solid green indicating that recovery is in progress. Once restoration is complete, the Cloud LED turns off and the system reboots. The restoration takes about 2 minutes to complete.

To cancel restoration

- Press `n`, then press `Enter`. Or, if the system does not detect any key-press within 30 seconds.

The Cloud LED turns off, and the system reboots.

Option 3: Restoring from boot menu

 **CAUTION: These steps will delete all the data on your Edge Gateway.**

1. Connect a USB keyboard and display to the Edge Gateway.
2. Power on the Edge Gateway.
3. Press `F12` when the Dell logo is displayed on the screen to enter the boot menu.
4. Select `Factory Restore` from the boot menu.
5. When you receive the message `Factory Restore will delete all user data, are you sure? [Y/N]`, press `Y`.

Restore Ubuntu Core 16 from USB flash drive

 **CAUTION: These steps will delete all the data on your Edge Gateway.**

Prerequisites

Create the recovery USB flash drive. For more information, see [Creating the recovery USB flash drive](#).

Procedure

 **NOTE: For a video tutorial on how to restore Ubuntu Core 16 from a USB flash drive on the Edge Gateway 3003, click [here](#).**

1. Insert the USB flash drive into the USB port on the Edge Gateway.
2. Power on the Edge Gateway.
3. The Edge Gateway boots through the USB flash drive and flashes the Ubuntu Core installation image into storage automatically.

 **NOTE: When the installation images are being flashed to the storage, the Power LED is solid green and Cloud LED is blinking green.**

4. The system powers off after the installation is complete.

 **NOTE: The installation takes about 3 minutes to complete.**

5. Remove the USB drive after the Edge Gateway powers off.

6. Power on the Edge Gateway again to continue the installation. The system reboots several times during the installation and takes about 10 minutes to complete.

Once installation is complete, a login screen is displayed.

 **NOTE: On the Edge Gateway 3003, the login screen is displayed only if the display port is connected a monitor.**

7. At the login screen, enter the default user name and password: `admin`.

The Edge Gateway is now ready for use.

 **NOTE: For more information about accessing Ubuntu on the Edge Gateway 3003 directly, see [Boot up and log in—Direct system configuration](#).**

Flashing a new OS image

Prerequisites

- A blank and FAT32–formatted USB flash drive with at least 4 GB of storage space
- Ubuntu Desktop ISO

 **NOTE: You can download the latest version of the Ubuntu Desktop ISO file from <http://releases.ubuntu.com>.**

- A released Ubuntu Core 16 image from Dell.com/support: `<unique name-date> img.xz`
- LCD monitor
- USB keyboard
- USB mouse
- DisplayPort cable
- Ubuntu workstation with Ubuntu Desktop 14.04 or higher

Flashing new Ubuntu OS image

1. Insert a USB flash drive into the Ubuntu Desktop workstation.
2. Copy `<unique name-date>img.xz` to `~/Downloads/` directory.
3. Flash the installation image to USB flash drive.
 - a. Start the **Terminal** application. It can be found by typing `Terminal` in the Unity Dash.

 **CAUTION: The `dd` command erases the content of the drive it writes to.**

- b. Type the following command and press Enter.

```
xzcat /cdrom/<unique name-date> img.xz | sudo dd  
of=/dev/sdb bs=32M ; sync
```

 **NOTE: The `sdb` may have to be replaced with the actual name of the drive on the system.**

4. Unmount and remove the USB flash drive.
5. Connect the power, keyboard, monitor, and Ethernet cable to your Edge Gateway.
6. Insert the USB flash drive into your Edge Gateway.
7. Power on and boot up the Edge Gateway from the USB flash drive.

The installation USB flash drive flashes the Ubuntu Core 16 installation image into storage automatically. After the installation is complete, the system shuts down.
8. Remove the USB flash drive.
9. Power on the system.

Ubuntu Core 16 is installed on your Edge Gateway.

Creating the recovery USB flash drive

Prerequisites:

- Service Tag of the Edge Gateway



- A Windows computer with administrator rights and at least 8 GB of available storage space to download the Dell ISO recovery image
 - A blank USB flash drive with at least 8 GB of storage space. These steps delete all data on the USB flash drive.
 - .NET Framework 4.5.2 or higher
1. Download and save the Dell ISO recovery image file from:
 - For Windows: dell.com/support/home/us/en/19/drivers/osiso/win
 - For Ubuntu: dell.com/support/home/us/en/19/drivers/osiso/linux
 2. Download and install the **Dell OS Recovery Tool** on your computer.
 3. Launch the **Dell OS Recovery Tool**.
 4. Click **Yes** in the **User Account Control** prompt.
 5. Connect the USB flash drive to the computer.
 6. Click **Browse** and navigate to the location where the Dell ISO recovery image file is saved.
 7. Select the Dell ISO recovery image file and click **Open**.
 8. Click **Start** to begin creating the bootable USB recovery media.
 9. Click **Yes** to continue.
 10. Click **OK** to complete.

Accessing and updating BIOS

Accessing BIOS settings

Use Dell Command | Configure (DCC) to access BIOS settings

Dell Command | Configure (DCC) is a factory-installed application in the Edge Gateway that helps to configure the BIOS settings. It consists of a Command Line Interface (CLI) to configure various BIOS features. For more information about DCC, see www.dell.com/dellclientcommandsuite/manuals.

- On the connected computer running Windows, click **Start** → **All Programs** → **Command Configure** → **Dell Command | Configure Wizard**
- On the connected computer running Ubuntu Core, access **Dell Command | Configure** using the command `dcc . cctk`

For more information on how to use the Dell Command | Configure application, see the Dell Command | Configure *Installation Guide* and *User's Guide* at www.dell.com/dellclientcommandsuite/manuals.

For more information about BIOS settings on the Edge Gateway, see [Default BIOS settings](#)

Use Edge Device Manager (EDM) to access BIOS settings

Edge Device Manager (EDM) enables you to perform remote management and system configuration. By using the EDM cloud console, you can view and configure the BIOS settings. For more information about the EDM, see www.dell.com/support/home/us/en/19/product-support/product/wyse-cloud-client-manager/research.

Entering BIOS setup during POST

 **NOTE: These steps are applicable only to the Edge Gateway 3003.**

1. Connect a display, keyboard and mouse to the system.
2. Power on the Edge Gateway.
3. During POST, when the Dell logo is displayed, watch for the F2 prompt to appear, and then press **F2** immediately.

Updating BIOS

 **NOTE: Download the latest BIOS file from dell.com/support/home/us/en/19/product-support/product/dell-edge-gateway-3000-series/drivers/.**

Select one of these options to update the BIOS on the Edge Gateway.

- [Using the USB invocation script](#)

 **NOTE: Dell recommends the use of the USB invocation script to update the BIOS.**

- (Edge Gateway 3003 only) [Flashing the BIOS from a USB flash drive](#)
- [Updating the BIOS on a Windows system](#)
- [Using UEFI capsule update on an Ubuntu system](#)
- [Dell Command | Configure \(DCC\)](#)



- [Edge Device Manager \(EDM\)](#)

Using the USB invocation script

The Edge Gateway 3000 Series come in headless configurations—that is, configurations without any video output. Certain basic system administration tasks traditionally accomplished by the BIOS Setup program are not possible without video. Hence, to perform these system administration tasks, Edge Gateways contain a facility for running an invocation script of BIOS commands from a USB flash drive.

For more information about USB invocation script, see the *Edge Gateway USB script utility User's Guide* at www.dell.com/support/home/us/en/19/product-support/product/dell-edge-gateway-3000-series/drivers/.

Flashing the BIOS from a USB flash drive

Prerequisites

- BIOS file. Download the file from www.dell.com/support.
- A blank USB 2.0 or 3.0 USB flash drive with at least 4 GB of storage space.

Follow these steps to update the BIOS:

1. Power off the Edge Gateway.
2. Copy the BIOS update file to a USB flash drive.
3. Insert the USB flash drive in one of the available USB ports on the Edge Gateway.
4. Power on the Edge Gateway.
5. Press **F12** when the system is starting up to enter the one-time boot screen.
6. On the one-time boot screen, choose **Flash the BIOS**.
7. In the next screen, select the BIOS file on the USB flash drive.
8. Start the flash process.

Updating the BIOS on a Windows system

Follow these steps to update the BIOS:

1. After connecting to the Edge Gateway.

 **NOTE: Connect and login to the Edge Gateway with one these options:**

- [Direct system configuration](#) (only for Edge Gateway 3003)
- [Static IP system configuration](#) (only for Edge Gateway 3002 and 3003)

2. Go to www.dell.com/support.
3. Click **Product support**, enter the Service Tag of your system, and then click **Submit**.

 **NOTE: If you do not have the Service Tag, use the auto-detect feature or manually browse to your system model.**

4. Click **Drivers & downloads**.
5. Select the operating system installed on your system.
6. Scroll down the page and expand **BIOS**.
7. Click **Download** to download the latest version of the BIOS for your system.
8. After the download is complete, navigate to the folder where you saved the BIOS file.
9. Double-click the BIOS update file icon and follow the instructions on the screen.

Using UEFI capsule update on an Ubuntu system

The `fwupdmgpt` tool or commands are used to update the UEFI BIOS on the system. The UEFI BIOS for this platform is released through online Linux Vendor File System (LVFS) based methods

Dell recommends that you enable the UEFI Capsule update by default so that it is running in the background to keep the system BIOS up to date.

 **NOTE:** For more information about `fwupd` commands, see www.fwupd.org/users.

Without an internet connection

1. Download the latest .cab file from secure-lvfs.rhcloud.com/lvfs/devicelist.

2. Check the current BIOS details.

```
$ sudo uefi-fw-tools.fwupdmgr get-devices
```

3. Copy the `firmware.cab` file to `/root/snap/uefi-fw-tools/common/` folder.

```
$ sudo cp firmware.cab /root/snap/uefi-fw-tools/common/
```

4. Check the details of the BIOS from the .cab file.

```
$ sudo uefi-fw-tools.fwupdmgr get-details [Full path of firmware.cab]
```

5. Apply the update.

```
$ sudo uefi-fw-tools.fwupdmgr install [Full path of firmware.cab] -v
```

6. Restart the system.

```
$ sudo reboot
```

With an internet connection

1. Connect and login to the Edge Gateway.

 **NOTE:** Connect and login to the Edge Gateway with one these options:

- [Direct system configuration](#) (only for Edge Gateway 3003)
- [Static IP configuration](#) (only for Edge Gateway 3002 and 3003)

2. Check the current BIOS details.

```
$sudo uefi-fw-tools.fwupdmgr get-devices
```

3. Check if the update is available from LVFS service.

```
$sudo uefi-fw-tools.fwupdmgr refresh
```

4. Download the BIOS from the www.dell.com/support.

```
$sudo uefi-fw-tools.fwupdmgr get-updates
```

5. Apply the update.

```
$sudo uefi-fw-tools.fwupdmgr update -v
```

6. Restart the system.

```
$ sudo reboot
```

Dell Command | Configure (DCC)

Use DCC to update and configure the BIOS settings.

For more information on how to use DCC, see the *DCC Installation Guide* and *User's Guide* at www.dell.com/dellclientcommandsuite/manuals.

For more information about BIOS settings on the Edge Gateway, see [Default BIOS settings](#).

Edge Device Manager (EDM)

BIOS can be updated remotely through the EDM console connected to a remote system.

For more information about EDM, see www.dell.com/support/home/us/en/19/product-support/product/wyse-cloud-client-manager/research.



Default BIOS settings

General (BIOS level 1)

Table 16. General (BIOS level 1)

BIOS level 2	BIOS level 3	Item	Default value	
System Information	System Information	BIOS Version	Not applicable	
		Service Tag	Not applicable	
		Asset Tag	Not applicable	
		Ownership Tag	Not applicable	
		Manufacturing Date	Not applicable	
		Ownership Date	Not applicable	
		Express Service Code	Not applicable	
	Memory Information	Memory Installed	Not applicable	
		Memory Available	Not applicable	
		Memory Speed	Not applicable	
		Memory Channel Mode	Not applicable	
		Memory Technology	Not applicable	
		Processor Information	Processor Type	Not applicable
			Core Count	Not applicable
	Processor ID		Not applicable	
	Current Clock Speed		Not applicable	
	Minimum Clock Speed		Not applicable	
	Maximum Clock Speed		Not applicable	
	Processor L2 Cache		Not applicable	
	Device Information	Processor L3 Cache	Not applicable	
		HT Capable	Not applicable	
		64-Bit Technology	Not applicable	
			eMMC Drive	Not applicable
			LOM MAC Address	Not applicable

BIOS level 2	BIOS level 3	Item	Default value
		LOM2 MAC Address	Not applicable
		Video Controller	Not applicable
		Video BIOS Version	Not applicable
		Wi-Fi Device	Not applicable
		Celluar Device	Not applicable
		Bluetooth Device	Not applicable
Boot Sequence	Boot Sequence	Boot Sequence - Depends on installed boot devices	Depends on installed boot devices
		Boot List option [Legacy/UEFI]	UEFI
Advanced Boot Options	Advanced Boot Options	Enable Legacy Option ROMs [Enable/Disable]	Enabled
Date/Time	Date/Time	Date [MM/DD/YY]	Not applicable
		Time [HH:MM:SS A/P]	Not applicable

System configuration (BIOS level 1)

Table 17. System configuration (BIOS level 1)

BIOS level 2	BIOS level 3	Item	Default value
Integrated NIC	Integrated NIC	Enable UEFI Network Stack [Enable/Disable]	Enabled
		[Disabled, Enabled, Enabled w/PXE]	Enabled w/PXE
	Integrated NIC 2	[Disabled, Enabled]	Enabled
USB Configuration	USB Configuration	Enable Boot Support [Enable/Disable]	Enabled
		Enable USB 3.0 Controller [Enable/Disable]	Enabled
		Enable USB Port1 [Enable/Disable]	Enabled
		Enable USB Port2 [Enable/Disable]	Enabled
	Audio	Enable Audio [Enable/Disable]	Enabled
	Miscellaneous Devices	Enable WWAN [Enable/Disable]	Enabled



BIOS level 2	BIOS level 3	Item	Default value
		Enable WLAN/Bluetooth [Enable/Disable]	Enabled
		Enable Dedicated GPS Radio [Enable/Disable]	Enabled
		Enable MEMs Sensor [Enable/Disable]	Enabled
Watchdog Timer Support	Watchdog Timer Support	Enable Watchdog Timer [Enable/Disable]	Disabled

Security (BIOS level 1)

Table 18. Security (BIOS level 1)

BIOS level 2	BIOS level 3	Item	Default value
Admin Password	Admin Password	Enter the old password	Not Set
		Enter the new password	Not applicable
		Confirm new password	Not applicable
System Password	System Password	Enter the old password	Not Set
		Enter the new password	Not applicable
		Confirm new password	Not applicable
Strong Password	Strong Password	Enable Strong Password [Enable/Disable]	Disabled
Password Configuration	Password Configuration	Admin Password Min	4
		Admin Password Max	32
		System Password Min	4
		System Password Max	32
Password Bypass	Password Bypass	[Disabled/Reboot Bypass]	Disabled
Password Change	Password Change	Allow Non-Admin Password Changes [Enable/Disable]	Enabled
UEFI Capsule Firmware Updates	UEFI Capsule Firmware Updates	Enable UEFI Capsule Firmware Updates [Enable/Disable]	Enabled
TPM 2.0 Security	TPM 2.0 Security	TPM 2.0 Security [Enable/Disable]	Enabled
		TPM On [Enable/Disable]	Enabled
		PPI Bypass for Enable Commands [Enable/Disable]	Disabled

BIOS level 2	BIOS level 3	Item	Default value
		PPI Bypass for Disable Commands [Enable/Disable]	Disabled
		Attestation Enable [Enable/Disable]	Enabled
		Key Storage Enable [Enable/Disable]	Enabled
		SHA-256 [Enable/Disable]	Enabled
		Clear [Enable/Disable]	Disabled
Computrace(R)	Computrace(R)	Deactivate/Disable/Activate	Deactivate
Chassis Intrusion	Chassis Intrusion	[Disable/Enable/On-Silent]	Disable
CPU XD Support	CPU XD Support	Enable CPU XD Support [Enable/Disable]	Enabled
Admin Setup Lockout	Admin Setup Lockout	Enable Admin Setup Lockout [Enable/Disable]	Disabled

Secure boot (BIOS level 1)

Table 19. Secure boot (BIOS level 1)

BIOS level 2	BIOS level 3	Item	Default value
Secure Boot Enable	Secure Boot Enable	[Enable/Disable]	Disabled
Expert Key Management	Expert Key Management	Enable Custom Mode [Enable/Disable]	Disabled
		Custom Mode Key Management {PK/KEK/db/dbx}	PK

Performance (BIOS level 1)

Table 20. Performance (BIOS level 1)

BIOS level 2	BIOS level 3	Item	Default value
Inter SpeedStep		Enable Intel SpeedStep [Enable/Disable]	Enabled
C-States Control	C-States Control	C-states [Enable/Disable]	Enabled
Limit CPUID Value	Limit CPUID Value	Enable CPUID Limit [Enable/Disable]	Disabled



Power management (BIOS level 1)

Table 21. Power management (BIOS level 1)

BIOS level 2	BIOS level 3	Item	Default value
Auto On Time	Auto On Time	Time Selection: [HH:MM A/P] Auto On Time (if Wake Period =0)	12:00AM
		Value Selection: [0-254] Auto-Wake Period (0-254 minutes)	000
		Day Selection: [Disabled/Every Day/Weekdays/Select Days]	Disabled
		Under [Select Days] when enabled [Sunday/Monday.../Saturday]	Not applicable
Wake on LAN/WLAN	Wake on LAN/WLAN	[Disabled/LAN Only/WLAN only/LAN or WLAN]	Disabled

POST behavior (BIOS level 1)

Table 22. POST behavior (BIOS level 1)

BIOS level 2	BIOS level 3	Item	Default value
Numlock LED	Numlock LED	Enable Numlock LED [Enable/Disable]	Enabled
Keyboard Errors	Keyboard Errors	Enable Keyboard Error Detection [Enable/Disable]	Enabled
Fastboot	Fastboot	[Minimal/Thorough/Auto]	Thorough
Extend BIOS POST Time	Extend BIOS POST Time	[0 seconds/5 seconds/10 seconds]	0 seconds
Full Screen Logo	Full Screen Logo	Enable Full Screen Logo [Enable/Disable]	Disabled
Warnings and Errors	Warnings and Errors	[Prompt on Warnings and Errors/Continue on Warnings/Continue on Warnings and Errors]	Prompt on Warnings and Errors

Virtualization support (BIOS level 1)

Table 23. Virtualization support (BIOS level 1)

BIOS level 2	BIOS level 3	Item	Default value
Virtualization	Virtualization	Enable Intel Virtualization Technology [Enable/Disable]	Enabled

Maintenance (BIOS level 1)

Table 24. Maintenance (BIOS level 1)

BIOS level 2	BIOS level 3	Item	Default value
Service Tag	Service Tag	<System Service Tag>, text entry capability when blank	Not applicable
Asset Tag	Asset Tag	<System Asset Tag>, text entry capability	Not applicable
SERR Messages	SERR Messages	Enable SERR Messages [Enable/Disable]	Enabled
BIOS Downgrade	BIOS Downgrade	Allow BIOS Downgrade [Enable/Disable]	Enabled
Data Wipe	Data Wipe	Wipe on Next Boot [Enable/Disable]	Disabled
BIOS Recovery	BIOS Recovery	BIOS Recovery from Hard Drive [Enable/Disable]	Enabled

System logs (BIOS level 1)

Table 25. System logs (BIOS level 1)

BIOS level 2	BIOS level 3	Item	Default value
BIOS Events	BIOS Events	List of BIOS events with "Clear Log" button to clear the log	Not applicable

References

In addition to the *Installation and Operation Manual*, you can see the following documents available at www.dell.com/support/manuals.

- *Dell Edge Gateway Specifications*
- *Dell Edge Gateway Service Manual*
- *Dell SupportAssist For Dell OpenManage Essentials Quick Start Guide*
- *Dell Command | Configure User's Guide*
- *Dell Command | Configure Reference Guide*
- *Dell Command | Monitor User's Guide*
- *Dell Command | PowerShell Provider User's Guide*

For more information on using **Dell Data Protection | Encryption** see the documentation for the software at www.dell.com/support/manuals.

Appendix

Antenna specifications

The Edge Gateway is a professionally installed equipment. The Radio Frequency output power does not exceed the maximum limit allowed in the country of operation.

 **CAUTION: Unauthorized antennas, modifications, or attachments may damage the device and potentially violate international regulations.**

 **NOTE: Use only the supplied or an approved replacement antenna.**

 **NOTE: Modifications to the device or use of unauthorized antennas not expressly approved by Dell is the sole responsibility of the user or configurator or operator to reassess the equipment in accordance to all applicable international Safety, EMC, and RF standards.**

The Dell authorized antenna specifications are as follows:

- Mobile Broadband
 - Main: Dipole
 - LTE Auxiliary: PIFA
- GPS/WiFi/Zigbee: Monopole

The following tables provide the gain specifications for different antenna positions.

Table 26. Mobile broadband main antenna maximum gain (dBi)

Frequency (MHz)	Antenna position—Bent		Antenna position—Straight	
	3G (dBi)	4G (dBi)	3G (dBi)	4G (dBi)
704~806	Not applicable	2	Not applicable	1.7
824~894	1	1.4	2.1	2.1
880~960	0.5	1.4	1.4	1.5
1710~1880	3.2	4.2	1.9	3
1850~1990	3.9	4.3	3.2	3.4
1920~2170	4	4.4	3.2	3.4

Table 27. Mobile broadband auxiliary antenna maximum gain (dBi)

Frequency (MHz)	Antenna position—Bent		Antenna position—Straight	
	4G (dBi)		4G (dBi)	
704~806	0.6		1.9	
824~894	-0.3		-0.1	
880~960	-1.9		-2.5	
1710~1880	2.3		2.0	
1850~1990	3.6		3.2	
1920~2170	3.6		3.2	

Table 28. WiFi/GPS antenna maximum gain (dBi)

Frequency (MHz)	Antenna position—Bent		Antenna position—Straight	
	GPS (dBi)	WLAN (dBi)	GPS (dBi)	WLAN (dBi)
1561~1602	2.6	Not applicable	2.4	Not applicable
2400~2500	Not applicable	3.4	Not applicable	1.6

De-mounting from DIN-rail bracket

1. Pull the Edge Gateway down to release from DIN-rail bracket.
2. Lift the Edge Gateway bracket off the DIN rail.

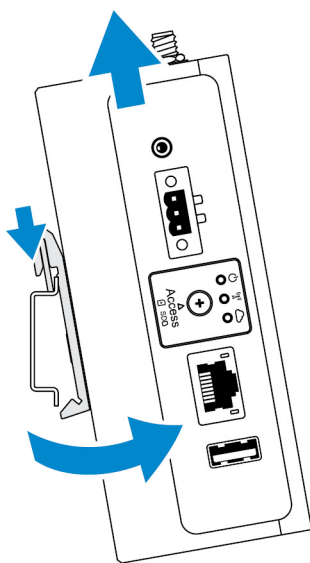

Connecting to the Edge Gateway

Windows 10 IoT Enterprise LTSC 2016

Boot up and login – Direct system configuration

1. Connect a monitor, keyboard and mouse to the Edge Gateway before you login.
2. Power on the Edge Gateway. At the first boot, you will not be prompted to enter login credentials. Subsequent boots will prompt for you to log in.

 **NOTE: The default user name and password are both `admin`.**

Boot up and login—Static IP system configuration

 **NOTE: To help set up the Edge Gateway remotely, the static IP address of Ethernet port two on the Edge Gateway is set to these values at the factory:**

- IP address: 192.168.2.1
- Subnet mask: 255.255.255.0
- DHCP server: Not applicable

You can connect your Edge Gateway to a Windows computer that is on the same subnet using a crossover cable.

1. On the Windows computer, search for **View network connections** in the control panel.
2. In the list of network devices displayed, right-click the Ethernet adaptor that you want to use to connect to the Edge Gateway, then click **Properties**.
3. On the **Networking** tab, click **Internet Protocol Version 4 (TCP/IPv4) → Properties**.
4. Select **Use the following IP address**, then enter 192.168.2.x (where x represents the last digit of the IP address, for example, 192.168.2.2).

 **NOTE: Do not set the IPv4 address to the same IP address as the Edge Gateway. Use an IP address between 192.168.2.2 to 192.168.2.254.**

5. Enter the subnet mask 255.255.255.0, then click **OK**.
6. Secure a crossover network cable between Ethernet port two on the Edge Gateway and the configured Ethernet port on the computer.
7. On the Windows computer, launch **Remote Desktop Connection**.
8. Connect to the Edge Gateway using the IP address 192.168.2.1. The default username and password are both `admin`.

Ubuntu Core 16

Boot up and log in – Remote system configuration

1. Connect a network cable from Ethernet port one on the Edge Gateway to a DHCP-enabled network or router that provides IP addresses.
2. In your network's DHCP server, use the command `dhcp-lease-list` to obtain the IP address associated with the Edge Gateway's MAC address.
3. Setup an SSH session using an SSH terminal emulator (for example, native command-line ssh client on Linux or PuTTY on Windows).

 **NOTE: The SSH service is enabled on Ubuntu Core 16 by default.**

4. Enter the command `ssh admin@<IP address>`, followed by the default user name and password. The default user name and password are both `admin`.



For example;

```
lo@lo-Latitude-E7470:~$ ssh admin@10.101.46.209
admin@10.101.46.209's password:
```

Boot up and log in – Static IP system configuration

This allows you to connect your Edge Gateway through a host computer, which must be on the same subnet.

 **NOTE: The static IP address of Ethernet port two on the Edge Gateway is set to these values at the factory:**

- IP address: 192.168.2.1
- Subnet mask: 255.255.255.0
- DHCP server: Not applicable

1. On the host computer, configure the Ethernet adaptor that is connected to the Edge Gateway with a static IPv4 address under the same subnet. Set the IPv4 address to 192.168.2.x (where x represents the last digit of the IP address, for example, 192.168.2.2).

 **NOTE: Do not set the IPv4 address to the same IP address as the Edge Gateway. Use an IP address between 192.168.2.2 to 192.168.2.254.**

2. Set the subnet mask to 255.255.255.0.

Contacting Dell

To contact Dell for sales, technical assistance, or customer service issues:

1. Go to www.dell.com/contactdell.
2. Verify your country or region in the drop-down list at the bottom of the page.
3. Select the appropriate service or support link based on your requirement or choose the method of contacting Dell that is convenient for you.

Dell provides several online and telephone-based support and service options. Availability varies by country and product, and some services may not be available in your area.



NOTE: If you do not have an active internet connection, you can find the contact information on your purchase invoice, packing slip, bill, or Dell product catalog.