

## 1 Before You Begin

**Warning!** Before you set up and operate your Dell storage system, review the safety instructions that came with your storage system.

### Unpack Storage Center Equipment

A Dell SCv3000 series storage system includes:

- Documentation
- Storage system
- Front bezel
- Rack rails
- Power cables (2)
- USB cables (2)

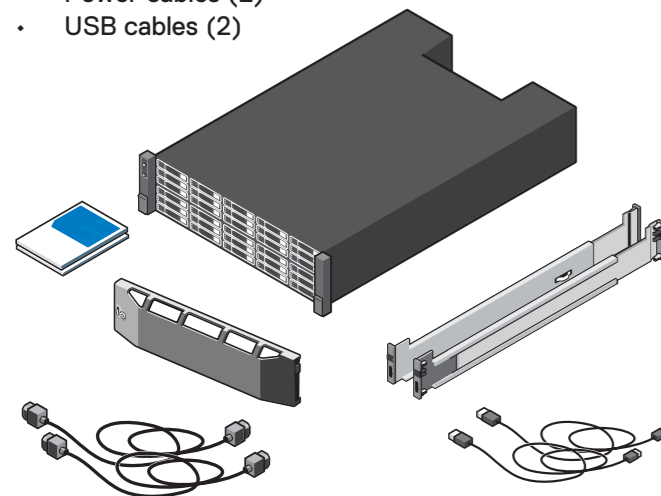

### Develop a Configuration Plan

Before installing the storage hardware, develop a configuration plan where you can record host server information, switch information, and network information.

### Record System Information

- System management IPv4 address for Storage Center
- IPv4 address of the MGMT port on each storage controller
- Domain name
- DNS server address

### Consider Plans for Multipath/Failover

Redundancy is provided by fault domains, which allow alternate paths if a path fails. Fault domains are determined by the number of independent fabrics. Each switch carries a separate fault domain. If a port fails, any port within the same fault domain takes over for the failed port. Dell recommends using multipathing, so that volumes are mapped to ports in more than one fault domain.

### More Information

For operating system, NIC or iSCSI host bus adapter (HBA), and switch requirements, refer to the *Dell Storage Compatibility Matrix* on the Dell Tech Center at <http://en.community.dell.com/techcenter/storage>.

## 2 Mount the Chassis and Optional Enclosures

**Warning!** The chassis is heavy. Do not attempt to lift the chassis without assistance.

Use the racking instructions included with your package to mount the chassis.

Mount the storage system chassis and expansion enclosures in a manner that allows for expansion in the rack and prevents the rack from becoming top-heavy. Secure the storage system chassis to the rack using the mounting screws that are located behind the latches on each chassis ear. Dell recommends mounting the storage system chassis in the bottom of the rack.

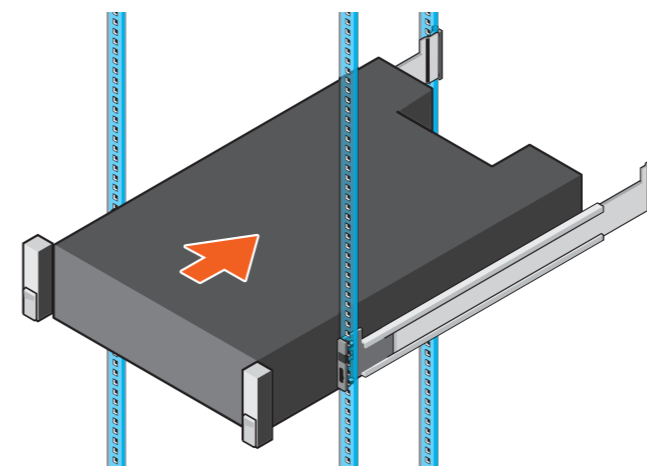

## 3 Install the Bezel

1. Hold the bezel with the logo upright.
2. Hook the right end of the bezel into the right side of the chassis.
3. Swing the left end of the bezel toward the left side of the chassis.
4. Press the bezel into place until the release latch closes.
5. Use the key to lock the front bezel.

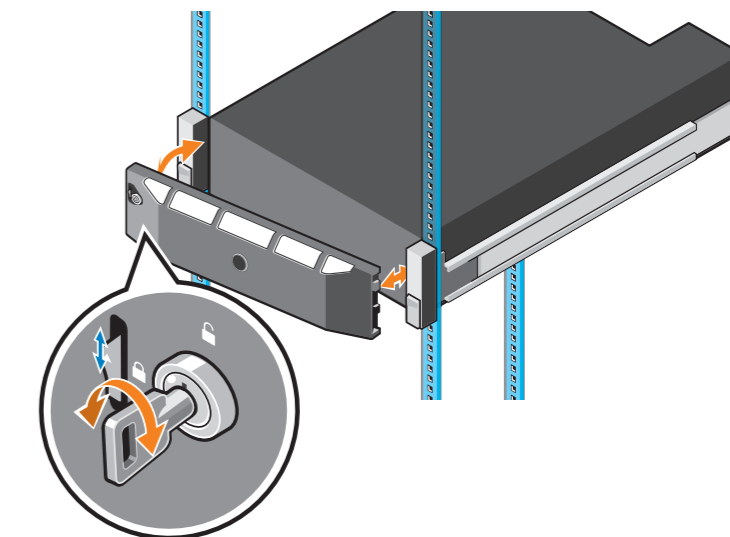

## 4 Cable the Host Servers to the Storage System

Fault domains provide fault tolerance at the storage controller level. Dell recommends using redundant cabling to avoid a single point of failure.

1. Identify the protocol being used to connect the host servers to the disk array.
2. Refer to the diagram below that corresponds to the proper protocol. These cabling guidelines ensure the configuration has redundancy and failover capability.

### iSCSI IO Card Cabling

Connect the host servers and storage system to the corresponding Ethernet switches.

#### iSCSI 4 Port Configuration

1. Install the NIC or iSCSI HBAs in the host servers.
2. Connect each host server to both switches.
  - Connections shown in orange belong to fault domain 1.
  - Connections shown in blue belong to fault domain 2.
3. Connect fault domain 1 (in orange) to switch 1.
  - Top storage controller: port 1 to switch 1
  - Top storage controller: port 3 to switch 1
  - Bottom storage controller: port 1 to switch 1
  - Bottom storage controller: port 3 to switch 1
4. Connect fault domain 2 (in blue) to switch 2.
  - Top storage controller: port 2 to switch 2
  - Top storage controller: port 4 to switch 2
  - Bottom storage controller: port 2 to switch 2
  - Bottom storage controller: port 4 to switch 2

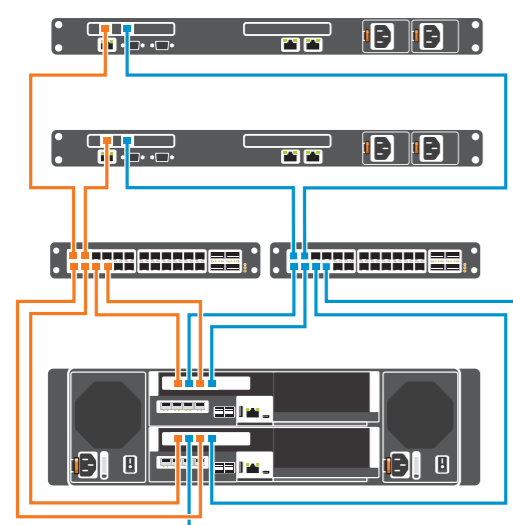

#### iSCSI 2 Port Configuration

1. Install the NIC or iSCSI HBAs in the host servers.
2. Connect each host server to both switches.
  - Connections shown in orange belong to fault domain 1.
  - Connections shown in blue belong to fault domain 2.
3. Connect fault domain 1 (in orange) to switch 1.
  - Top storage controller: port 1 to switch 1
  - Bottom storage controller: port 1 to switch 1
4. Connect fault domain 2 (in blue) to switch 2.
  - Top storage controller: port 2 to switch 2
  - Bottom storage controller: port 2 to switch 2

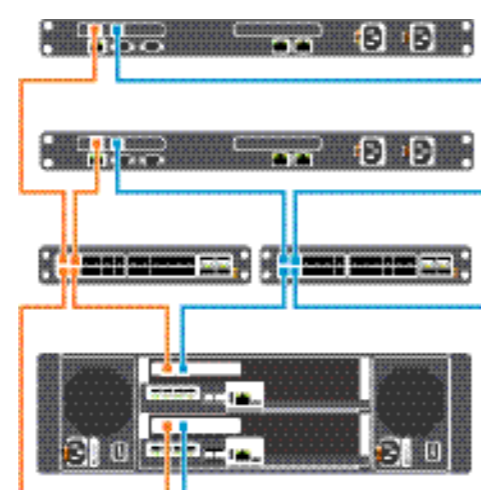

## 5 Connect to Management Network

The Ethernet management interface of each storage controller must be connected to a management network. The Ethernet management port provides access to the Storage Center and is used to send emails, alerts, SNMP traps, and support data.

1. Connect the Ethernet management port on the top storage controller to the Ethernet switch.
2. Connect the Ethernet management port on bottom storage controller to the Ethernet switch.

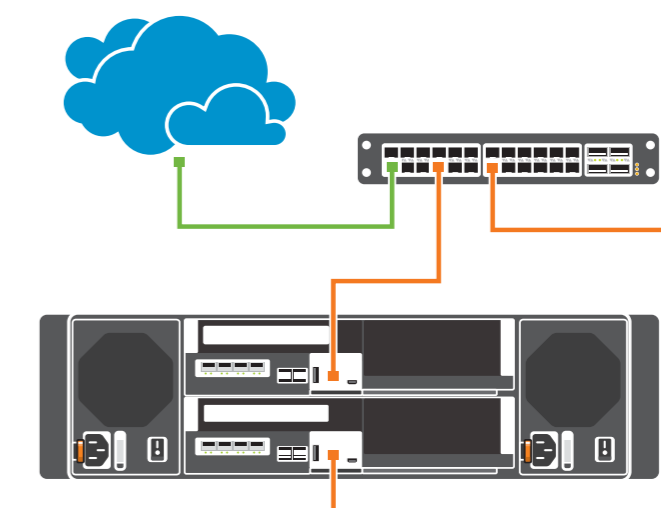



## 6 Cable the Backend

To add capacity to your storage system, you can connect up to sixteen SCv300, eight SCv320, or two SCv360 expansion enclosures to an SCv3000 series storage system. A maximum of 222 physical disks are supported in an SCv3000 series storage system.

Each expansion enclosure includes two Enclosure Management Modules (EMM) in two interface slots.

**NOTE:** If the storage system is installed without expansion enclosures, do not interconnect the back-end SAS ports on the storage controllers.

### Cable SCv300 or SCv320 Expansion Enclosures

To connect SCv300 or SCv320 expansion enclosures to the storage system:

#### Chain 1: A Side (Orange)

1. Connect part 1 on the top storage controller to port 1 on the top EMM of the first expansion enclosure.
2. Connect the remaining expansion enclosures in series from port 2 to port 1 using the top EMMs.
3. Connect port 2 on the top EMM of the last expansion enclosure to port 2 on the bottom storage controller.

#### Chain 1: B Side (Blue)

1. Connect port 1 on bottom storage controller to port 1 on the bottom EMM of the first expansion enclosure.
2. Connect the remaining expansion enclosures in series from port 2 to port 1 using the bottom EMM.
3. Connect port 2 on the bottom EMM of the last expansion enclosure to port 2 on the top storage controller.

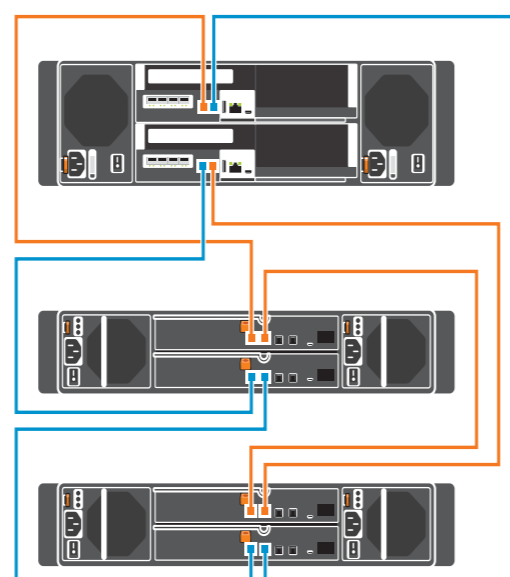

### Cable SCv360 Expansion Enclosures

To connect SCv360 expansion enclosures to the storage system:

#### Chain 1: A Side (Orange)

1. Connect part 1 on the top storage controller to port 1 on the top EMM of the first expansion enclosure.
2. Connect the remaining expansion enclosures in series from port 2 to port 1 using the top EMMs.
3. Connect port 2 on the top EMM of the last expansion enclosure to port 2 on the bottom storage controller.

#### Chain 1: B Side (Blue)

1. Connect port 1 on bottom storage controller to port 1 on the bottom EMM of the first expansion enclosure.
2. Connect the remaining expansion enclosures in series from port 2 to port 1 using the bottom EMM.
3. Connect port 2 on the bottom EMM of the last expansion enclosure to port 2 on the top storage controller.

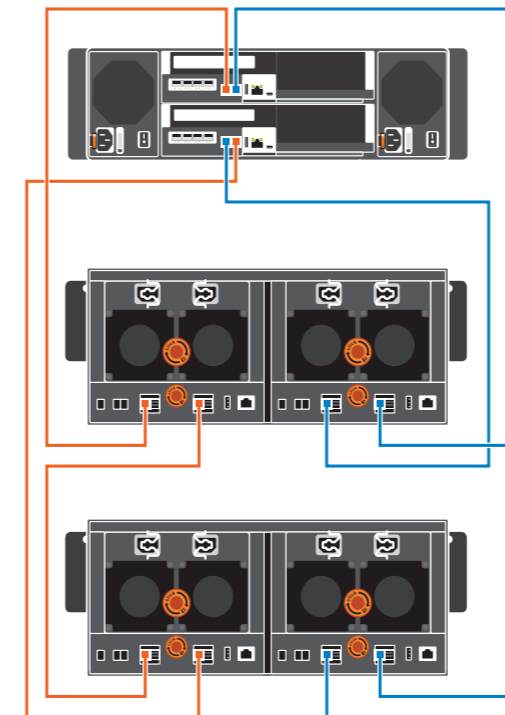

## 7 Connect the Power Cables

**CAUTION:** Make sure that the power switches are in the OFF position before connecting the power cables.

1. Connect the power cables to both power supply/cooling fan modules in the storage system chassis.

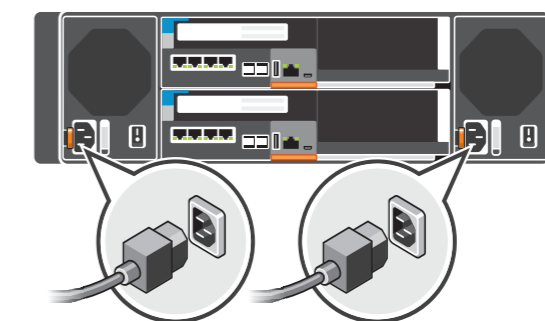

2. Use the velcro straps to secure the power cables to the storage system chassis.

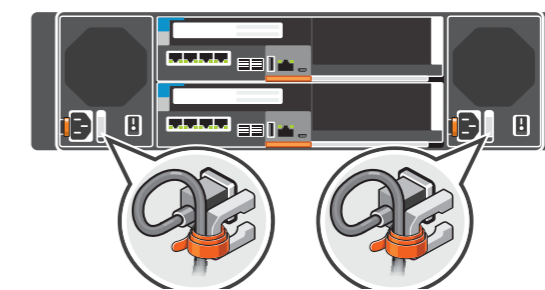

3. Plug the other end of the power cables into a grounded electrical outlet or a separate power source such as an uninterruptible power supply (UPS) or a power distribution unit (PDU).

## 8 Power on Storage System Components

1. Power on any network switches, routers, or other standalone components.
2. Power on any expansion enclosures that might be a part of the system.
3. Power on the storage system by turning on both power supply/cooling fan modules.

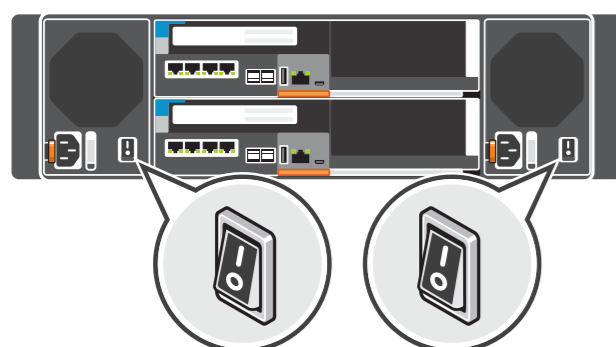

## 9 Download, Install, and Run the Dell Storage Manager Client

The Dell Storage Manager Client provides access to the initial setup wizards. The wizards help you remotely discover and configure storage systems and configure connected host servers.

**NOTE:** The initial setup wizards are only supported on 64-bit operating systems.

### Install and Start the Dell Storage Manager Client

1. Log in to the Dell Digital Locker at [www.dell.com/support/software](http://www.dell.com/support/software), register your storage system, and download the Windows or Linux version of the Dell Storage Manager Client.
2. Install the Dell Storage Manager Client on the host server. To discover and configure a Storage Center, the software must be installed on a host server that is located on the same subnet as the storage system. For host setup, the client does not have to be on the same subnet as the storage system.
3. To start the software on a Windows computer, right-click on the Dell Storage Manager Client shortcut and select **Run as administrator**. To start the software on a Linux computer, execute the command `./Client` from the `var/lib/dell/bin` directory. The Dell Storage Manager Client welcome screen opens.

### Discover and Configure Storage Center Wizard

1. Click the **Discover and Configure Uninitialized Storage Centers** link. The Discover and Configure Storage Center wizard opens.
2. Follow the steps in the wizard to discover and configure uninitialized Storage Centers.

**NOTE:** If the wizard does not discover the Storage Center, refer to the [Dell SCv3000 and SCv3020 Storage System Deployment Guide](#) for additional methods to deploy the Storage Center.

### Related Publications

The following documentation is available on the Dell support site for the Dell SCv3000 Series Storage Systems:

- Dell SCv3000 and SCv3020 Storage System Getting Started Guide
- Dell SCv3000 and SCv3020 Storage System Owner's Manual
- Dell Storage Center Release Notes
- Dell Storage Manager Administrator's Guide
- Dell Storage Manager Installation Guide
- Dell Storage Manager Release Notes

## 10 Attach the Host Servers

Refer to the [Dell Storage Compatibility Matrix](#) for a list of supported iSCSI network adapters.

### Windows and Linux Hosts

Install the iSCSI HBAs or network adapters, install the drivers, and make sure that the latest supported BIOS is installed.

1. Install the iSCSI HBAs or network adapters dedicated for iSCSI traffic in the host servers.
2. Install supported iSCSI HBA drivers and make sure that iSCSI HBAs have the latest supported firmware.
3. Use the iSCSI cabling diagrams to cable the host servers to switches. Connecting host servers directly to the storage system without using Ethernet switches is not supported.
4. Assign IP addresses to each iSCSI port to match the subnets for each fault domain.

**CAUTION:** Make sure to assign the correct IP addresses to the HBAs or network adapters. Assigning IPs to the wrong ports can cause connectivity issues.

**NOTE:** If using jumbo frames, enable and configure jumbo frames on all devices in the data path.

### VMware ESXi Hosts

Install the iSCSI HBAs or network adapters (NICs) and make sure that the latest supported BIOS is installed.

1. Install the iSCSI HBAs or NICs dedicated for iSCSI traffic in the ESXi hosts.
2. Use the iSCSI cabling diagrams to cable the ESXi hosts to switches. Connecting ESXi hosts directly to the storage system without using Ethernet switches is not supported.
3. Create a VMkernel port for each iSCSI HBA or NIC to be used for iSCSI.
4. Assign IP addresses for each adapter port to match the subnets for each fault domain.

**CAUTION:** Make sure to assign the correct IP addresses to the HBAs or network adapters. Assigning IPs to the wrong ports can cause connectivity issues.

**NOTE:** If using jumbo frames, enable and configure jumbo frames on all devices in the data path: adapter ports, switches, and storage system.

5. If using the software iSCSI initiator and the server has iSCSI offload, the iSCSI hardware initiator must be disabled.
6. If using iSCSI HBAs, configure Network Port Binding to add the VMkernel ports to the iSCSI Storage Adapter. Do not bind NICs to the software initiator.
7. If using software iSCSI initiator, add the Storage Center's iSCSI target IPs to the Dynamic Discovery.

### Configure Host Access to a Storage Center

1. For Windows and Linux servers, click the **Configure this host to access a Storage Center** link and log in to the Storage Center. For VMware ESXi servers, click **Configure VMware vSphere to access a Storage Center**.
2. Follow the steps in the wizard to configure the host to access the Storage Center and configure best practices for performing I/O.

When the host configuration is complete, use the Dell Storage Manager Client to create and map volumes.



### Notes, Cautions, and Warnings

- A **NOTE** indicates important information that helps you make better use of your product.
- A **CAUTION** indicates potential damage to hardware or loss of data and tells you how to avoid the problem.
- A **WARNING** indicates a potential for property damage, personal injury, or death.

