

# E0 PTT蓝牙耳机说明书

感谢您购买 德青科技E0 PTT蓝牙耳机。希望您能喜欢！本说明手册将帮助您充分了解和使  
用您的蓝牙耳机。

## 安全注意事项

禁止跌落以及冲击等有害本产品的行为发生，否则会造成机器故障的发生。

请勿长时间将本产品放置在近火或阳光直射的地方。

否则会引起火灾等故障的发生。

禁止在骑乘摩托车的同时，进行本产品的设定变更、手机通话等操作，以免引起交通事故的  
发生。万一，因骑乘过程中操作本产品或不当使用本产品而产生的任何伤害，本公司概不负  
责，敬请谅解。

避免骑乘中的通话行为。养成在路边安全停车之后再行进行通话的习惯。

发生冒烟、发烫、异臭等异常时，请立即切断电源，并停止使用。

如果继续使用可能会引起触电、火灾等事故的发生。

请勿拆卸、改装本产品，否则会造成产品破损或者触电、火灾等事故发生。

请勿将本产品放入口中，避免伤害事故的发生。

家里有儿童的使用者需要特别的注意存放。远离儿童。

本产品可在-15℃--45℃的温度环境中使用，超过此温度范围，  
本公司无法保证产品可以正常使用。

本公司产品所附配件均经过认证检验，如使用非本公司认证的配件可能影响  
产品正常使用。

## 充电注意事项

请务必使用本公司附带的 USB 线充电，否则会引起冒烟、起火等情况的发生。

如长时间不使用本产品时，至少半年充电一次，以免过度放电而导致电池损坏。

充电请使用 PC 的 USB 端子或者附带的 USB 端子输出电源适配器，并在常温下  
进行。请避免在近火处进行充电，以免引起冒烟和起火等情况的发生。

充电完成后，请不要使其长时间处于充电状态，以免引起冒烟和起火等情况的发生。

充电过程中，如果发生异臭、发烫等异常情况，请立即切断电源，停止充电，  
以免引起冒烟和起火等情况的发生。

## 产品描述

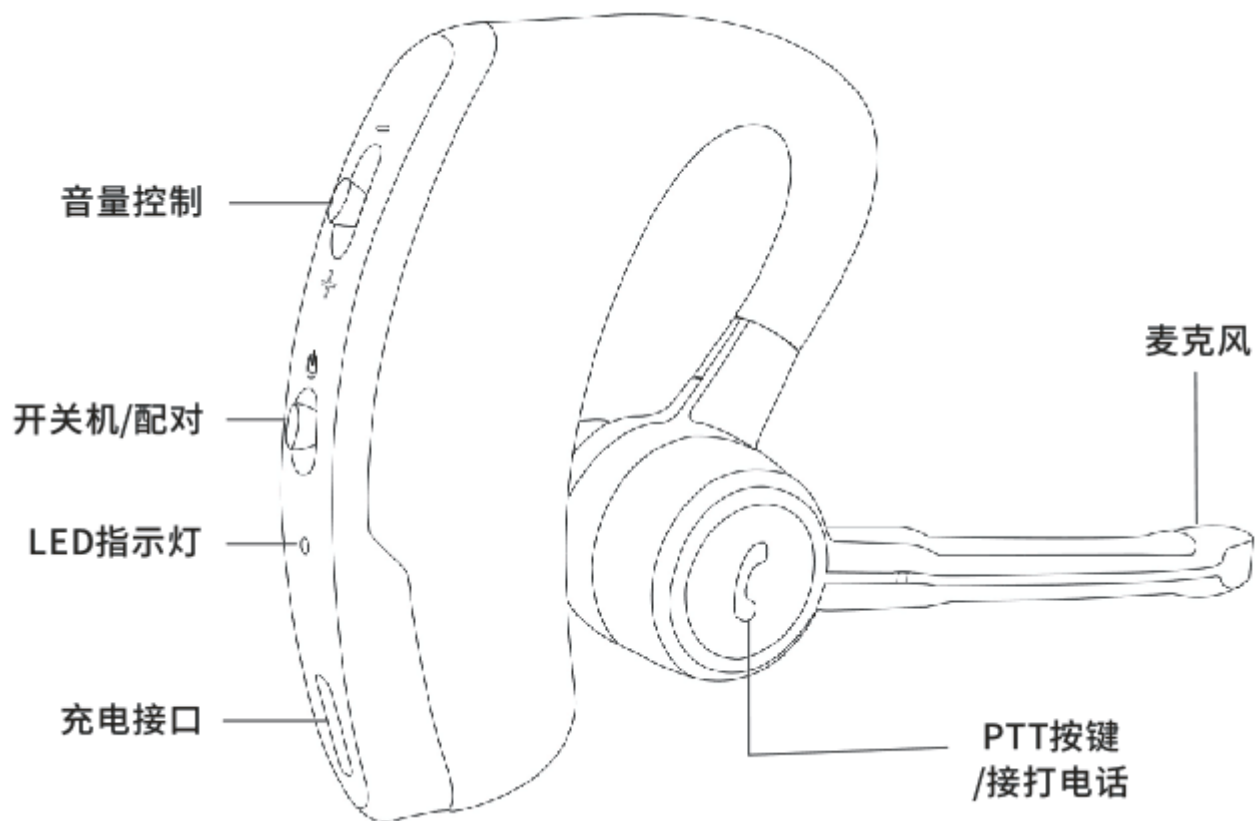

## 耳机功能

- ◇ PTT功能
- ◇ 接听来电
- ◇ 结束通话
- ◇ 拒绝来电

**注： 在使用耳机之前，请为耳机充电**

为了更好地使用蓝牙耳机，请确保您的耳机在使用前先充电两个小时，然后再进行使用。当指示灯呈红色一闪一闪时，表示耳机正在充电。当耳机完全充满电时，指示灯将变为红色长亮。请注意：如果长时间不对耳机充电，电池寿命会大大缩短。因此建议您每月至少为耳机充一次电。

## 开机和关机

- 🔌 - 关机状态下，往电源图标方向长按开关配对键3秒，蓝灯慢闪为开机。

 - 开机状态下，往电源图标方向长按开关配对键6秒，所有指示灯关闭为关机。

## 耳机与手机配对

### 1 使耳机处于配对模式

◇首次开启E0耳机时，请在关机的状态下，长按开关机键10秒进入红蓝指示灯快闪，进入配对模式，打开手机蓝牙设置，搜索蓝牙耳机设备名：Dellking PTT Mic 或含E0 相关设备名，点击手机搜索到的相关设备名，点击配对，配对成功后手机会显示连接成功，蓝牙耳机红蓝快闪指示灯进入蓝灯慢闪，即为配对成功。

### 2 设置蓝牙手机，使之发现“E0”

◇按照手机的说明书指南进行操作。首先确保已激活手机的蓝牙功能，然后设置手机使其找到耳机。这通常包括进入电话的“设置”、“连接”或“蓝牙”菜单并选择用来“发现”或“添加”蓝牙设备的选项。

### 3 您的手机将找到“E0”耳机

◇手机将找到名为“E0”的耳机，然后，手机将询问您是否希望与该耳机配对。按手机上的“是”或“确定”接受配对。如果手机要求您输入密码或 pin 码确认，则输入“0000”。手机会在完成配对时进行确认，指示灯将从红蓝快闪状态切换为蓝灯慢闪状态。

#### 注意：

1. 有些手机是不需要输入配对密码的。
2. 耳机与手机仅在首次配合使用时需要配对。当耳机与手机完成首次配对之后，只要耳机开启且手机已激活蓝牙功能，它们就会自动连接。如果耳机与手机已配对但没有立即连接，请轻按“PTT”按钮，或进入手机的蓝牙设置界面，选中配对的Dellking PTT Mic 或含E0 相关设备名，点击链接即可。

## 操作

### PTT (Push To Talk) 按住说话功能

◇配对完成后，即可使用蓝牙耳机 E0 控制手机里的对讲软件的 PTT 控制功能，如 app 有特殊设置，请在 app 设置处选择 Dellking PTT Mic 或含 E0 相关设备名蓝牙设备，同时确保 app 对讲模式是在蓝牙模式下进行，即 app 某个特定的地方显示的对讲模式（一般有扩音免提模式、手机听筒模式、蓝牙模式）。

◇同时若配对德青科技的对讲机适配器一起使用，也可以控制对讲机的 PTT 功能。

## 接听来电

- ◇ 轻按耳机上的PTT “” 按钮接听来电。

## 结束通话

- ◇ 双击PTT “” 按钮，结束当前通话。

## 拒绝来电

- ◇ 当电话铃声响起时，双击PTT “” 按钮，可以拒绝来电。  
根据您的电话设置，拨打来电的人会被转接到语音信箱或者听到忙音。

## 自动接听

- ◇ 当电话铃声响起时，如何10秒内，无任何操作，耳机将会自动接听来电。

## 拨打电话

- ◇ 使用手机拨打电话时，呼叫会自动转移到耳机（由电话的设置控制）。

## 调节声音和音量

- ◇ 往“-”号图标方向拨音量键并持续按住，音量会由大变小至最小音量。  
往“+”号图标方向拨音量键并持续按住，音量会由小增大至最大音量。

## 技术参数

版本	蓝牙V4.1
射频等级	Class2
传输范围	10米
支持模式	HFP、HSP、PTT
持续通话时间	6小时
待机时间	55小时
充电时间	小于3小时
工作温度	-15℃~45℃
存储温度	-25℃~60℃

## LED 状态及充电指示

LED 指示灯闪烁模式	状态指示
蓝灯每 1 秒闪烁一次	工作/待机模式
红蓝灯交替快闪	配对模式
红蓝灯每 2 秒闪烁一次	低电量
红灯每 1 秒闪烁一次	正在充电
红灯长亮	充电完成

## 故障排除和常见问题解答

### 我听到了噼啪的噪声

◇ 作为一种无线电技术，蓝牙对耳机与所连接设备之间的物体很敏感。根据设计规格，耳机与所连接设备的使用间距应保持在 10 米（33 英尺）之内，而且二者之间不应存在大型物体（如墙壁等）。

### 我的耳机听不到任何声音

- ◇ 增大耳机的音量。
- ◇ 确保耳机已与正在通话的设备配对正确。
- ◇ 通过轻按“接听 / 结束”按钮确认耳机已与您的手机正确配对。

### 配对不成功，怎么办？

◇ 您可能在手机中删除了耳机配对连接。请按照配对说明操作。

### 无法开机，怎么办？

◇ 把耳机插上 USB 充电线充电 3 小时直至红灯长亮再次重新开机。

# E0 Bluetooth Headset User Manual

## Please read below content carefully before using

Thanks for purchasing E0 Bluetooth helmet intercom headset, may you will enjoy it. Please read the “Safety Instructions” before using the product for your safety and correct use.

### Caution

Do not immerse in water to avoid damaging the product as well as shortening its lifetime.
---

DO NOT drop or apply shock to the product. Such act may cause irreparable damage to the product.
--

DO NOT expose the product to open flame or under the direct sunlight for a prolonged period of the time. Such environment may cause malfunction or fire.
--

Please do not change the setting or talk on the cell phone while driving. It may cause an accident. Please note: in no event our product shall be liable for any special, indirect, punitive, incidental, exemplary or consequential damages, or any damages whatsoever resulting from the usage of this product.
---

Conversation on the cell phone when driving is extremely dangerous. Please go out of the road for doing the telephone call.
---

If anything unusual such as smoke, heat or bad smell is detected, please disconnect immediately the power and stop the usage. Continuing the use may cause electric shock or fire.
--

DO NOT lick, bite or put the product into the mouth. Such act may result in serious injuries/accidents. Take utmost caution around children.
--

DO NOT change the mic when it gets wet. With water exposure, it may cause fire, electrification or failure.
---

Temperature range of use: -15°C-45°C
--------------------------------------

Please use only qualified accessories which have been authenticated by us, in order to guarantee the product correct functioning.
---

### Note on battery charge

For battery charge, use USB terminal or USB adaptor at normal temperature.
--

Use regulation USB terminal only. Otherwise it may cause smoke generation or fire.
--

When charging the battery, if any strange odor or high heat should broken out, please immediately pull the plug from the body. It may cause smoke generation or fire.
---

Do not leave the product in a state of charge long after the charging is completed. Such condition may cause smoking/ignition.
--

Charge battery at least once every six months even if the product is not use for an extended period of time. Over discharge may require battery replacement.
--

## Product description:

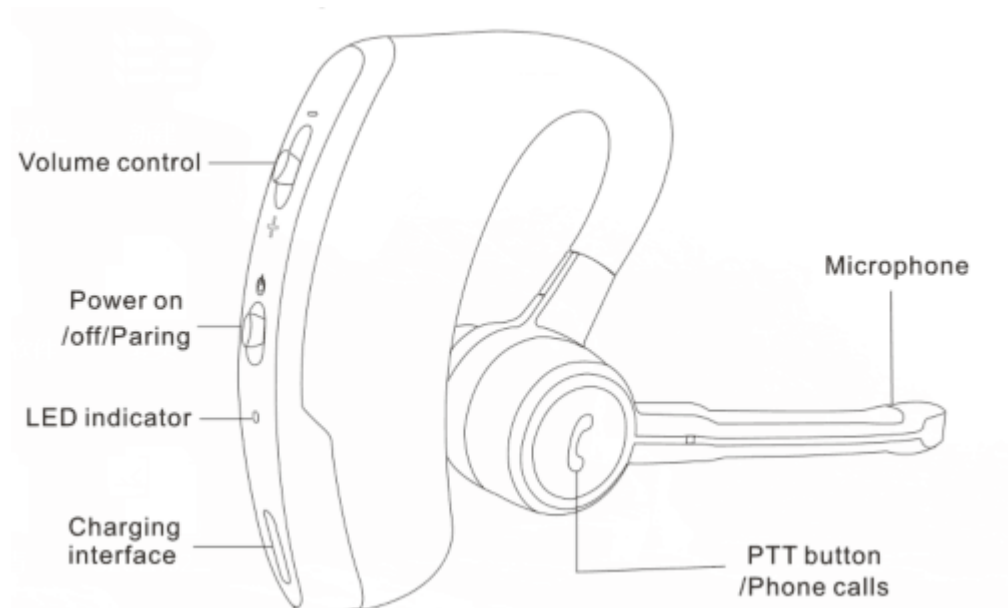

## Function:

- ◇ PTT function
- ◇ Answer incoming call
- ◇ Hang up call
- ◇ Reject incoming call

### Before using the headset, please recharge headphones

Make sure your headset is fully charged three hours before use. From a mains socket. When a red light blinks, indicating the headset is under charging. After the headset has been fully charged, the indicator will show a solid red light. Please note: if it has been left too long without being charged, the battery life may be greatly reduced. Therefore, it is recommended that you charge the E0 BT headset at least once a month.

## Operation

 **Power on**

In power off state, press **Power on/off Button** and hold it for about 3 seconds, until you hear a “di” tone, release the button, the blue indicator will flash slowly to indicate power on successfully.

## **Power off**

In power on state, press **Power on/off Button** towards to power icon and hold it for about 6 seconds, until hear a long “di” tone, red indicator will flash quickly to indicate power off.

## **Pairing with mobile phone**

- ① Place the E0 Bluetooth headset and the mobile phone in a visible area within 1 meter range.
- ② Make sure the Bluetooth headset is in power off state.
- ③ Turn **Power on/off Button** towards to power icon for about 8 seconds, when the Blue LED and the Red LED flashing alternately, release the button then the E0 Bluetooth headset is in pairing state now.
- ④ Follow the user manual of your mobile phone, turn on the Bluetooth function, and searching the Bluetooth headset devices
- ⑤ From the found devices in your mobile phone, select the device named “DellKing PTT Mic” or “E0”, and then try to pair with it, when it prompts to enter password, enter pin code <0000>. Once paired successful, LED Indicator will change from Blue/Red alternately to Blue flashing, and with a “di” tone to note that the Bluetooth headset has connected with your mobile phone. Now you can use the headset to push to talk or answer you phone call.

Note:

- 1. Password code may be not necessary for some mobile phones.**
- 2. The pairing will be remembered after the first pair, so when you second or next time use the device, do not need to pair again.**





## Push To Talk Function For Poc App and Radio Phone

After connected to your cell phone Poc(Ptt Over Cellphone) app or DellKing Bluetooth Dongle/Adapter with E0, just push the PTT button to remote control the PTT function. Some Poc app may need some setting change to Bluetooth before use. Details please refer to the user guide of Poc App.

**Note: Poc means PTT Over Cell Phone.**



### Phone call operation

#### Answer incoming call

① When there is an incoming phone call, press Power PTT Button  to answer the call, or it may be automatically answered if there's no user operation for 10s.

#### ② Reject incomin

Double press **Power PTT Button**  to reject an incoming phone call.

#### ③ Hang up call

In call active state, double press **PTT Button**  to hang up the call.

#### ④ Voice dial

While the E0 is connected with the mobile phone, quick double press **Volume + Button**, then the mobile will prompt you to speak out your desired name.

(Note: Voice dial need Mobile Phone supports correspond HFP Voice Dial function )

#### Volume control

Turn volume control button towards to “+” icon and hold it, the volume will be louder and louder, When maximum volume reached, a remind tone will be played. Turn volume control button to “-” icon and hold it, the volume will be turned lower and lower, when minimum volume reached a remind tone will be played.

## Technical Specification:

Model	E0
Bluetooth version	V4.1 Class 2
Operation range	10m
Profile	HFP,HSP,PTT
Talking time	About 6 hours
Standby time	About 55 hours
Charging time	Less than 3 hours
Working temperature	-15°C ~ 45°C
Storage temperature	-25°C ~ 60°C

## About Led Indicator and Charging

LED indicator flash mode	State of indication
LED indicator flashes blue every 1s	Working/Standby mode
LED indicator flashes red/blue alternately and quickly	Pairing mode
LED indicator flashes red and blue every 2s	Battery low
LED indicator flashes red every 1s	Charging
LED indicator keeps red	Charging completed

## **FAQ :**

### **1,Can not power on**

It might low battery, please try again after charging for 3 hours, then power on again.

### **2,No sound**

Please check if the speaker mic have connected to the device or the volume too low?

### **3,Disconnect with mobile phone, Bt Adapter/dongle, or GPS**

Make sure if it is low battery, if not, the distance between the speaker mic and mobile phone within 10m? Or between them exist obstacles that absorb frequency signals like metals or water?

### **4,Fail to re-connect or automatically re-connect with mobile phone**

First make sure your Bluetooth function in in your mobile phone have been turned on, then remove all the paired Bluetooth device in you cell phone. Then turn off your mobile phone, restart mobile phone and pair with Bluetooth speaker-mic and set the headset read as “default/trust/test/permit automatically connection/always visible/allow to be found” device, and further ensure that the phone prompt tone is not vibrating mode (because the vibrating impulse wave would interfere with Bluetooth frequency signal sometimes), then repair and connect with your mobile phone. For android system, please make sure in the Bluetooth device option list, you have “Phone” options selected.

### **5,System halted**

Use USB cable to charge the headset once then the headset will reset itself..

### **6,Abnormal instruction of Charging indicator**

- 1) When the headset haven' t been used for long time or overused, it need to be pre-charge for an hour, then pull out and in the charger, it will indicate normal charging. Please don' t count the pre-charging time into normal charging time.
- 2) Try another charging cable or charger.

### **7,Crackle**

Put E0 headset nearer (less than 10 meter range) to your cell phone. Put E0 and cellphone in a least obstacle blocking range.

**8,Please send back your BT Speaker-mic head set to our after-sales service department for help if above for help if above suggestions fail to solve your problem.**

NOTE: This equipment has been tested and found to comply with the limits for a Class B digital device, pursuant to part 15 of the FCC Rules. These limits are designed to provide reasonable protection against harmful interference in a residential installation. This equipment generates uses and can radiate radio frequency energy and, if not installed and used in accordance with the instructions, may cause harmful interference to radio communications. However, there is no guarantee that interference will not occur in a particular installation. If this equipment does cause harmful interference to radio or television reception, which can be determined by turning the equipment off and on, the user is encouraged to try to correct the interference by one or more of the following measures:

- Reorient or relocate the receiving antenna.
- Increase the separation between the equipment and receiver.
- Connect the equipment into an outlet on a circuit different from that to which the receiver is connected.
- Consult the dealer or an experienced radio/TV technician for help

Changes or modifications not expressly approved by the party responsible for compliance could void the user's authority to operate the equipment. This device complies with Part 15 of the FCC Rules. Operation is subject to the following two conditions:

- (1) this device may not cause harmful interference, and
- (2) this device must accept any interference received, including interference that may cause undesired operation.