

FCC ID: H79DB-995

EUT: COLOR MONITOR

DELTA ELECTRONICS, INC.

USER'S MANUAL

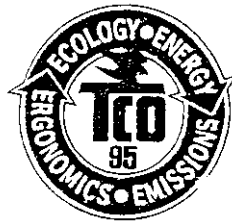

Congratulations! You have just purchased a TCO'95 approved and labelled product! Your choice has provided you with a product developed for professional use. Your purchase has also contributed to reducing the burden on the environment and to the further development of environmentally-adapted electronic products.

Why do we have environmentally-labelled computers?

In many countries, environmental labelling has become an established method for encouraging the adaptation of goods and services to the environment. The main problem as far as computers and other electronic equipment are concerned is that environmentally harmful substances are used both in the products and during their manufacture. Since it has not been possible so far for the majority of electronic equipment to be recycled in a satisfactory way, most of these potentially damaging substances sooner or later enter Nature.

There are also other characteristics of a computer, such as energy consumption levels, that are important from both the working and natural environment viewpoints. Since all types of conventional electricity generation have a negative effect on the environment (acidic and climate-influencing emissions, radioactive waste, etc.), it is vital to conserve energy. Electronic equipment in offices consumes an enormous amount of energy, since it is often routinely left running continuously.

What does labelling involve?

This product meets the requirements for the TCO'95 scheme, which provides for international environmental labelling of personal computers. The labelling scheme was developed as a joint effort by the TCO (The Swedish Confederation of Professional Employees), Naturskyddsforeningen (The Swedish Society for Nature Conservation) and NUTEK (The National Board for Industrial and Technical Development in Sweden).

The requirements cover a wide range of issues: environment, ergonomics, usability, emission of electrical and magnetic fields, energy consumption and electrical and fire safety.

The environmental demands concern among other things restrictions on the presence and use of heavy metals, brominated and chlorinated flame retardants, CFCs (freons), and chlorinated solvents. The product must be prepared for recycling and the manufacturer is obliged to have an environmental plan, which must be adhered to in each country where the company implements its operational policy.

The energy requirements include a demand that the computer and/or display after a certain period of inactivity shall reduce its power consumption to a lower level, in one or more stages. The length of time to reactivate the computer shall be reasonable for the user.

Labelled products must meet strict environmental demands, for example in respect of the reduction of electric and magnetic fields, along with physical and visual ergonomics and good usability.

FEDERAL COMMUNICATIONS COMMISSION

NOTE

This equipment has been tested and found to comply with the limits for a Class B digital device, pursuant to Part 15 of the FCC Rules. These limits are designed to provide reasonable protection. This equipment generates, uses and can radiated radio frequency energy and, if not installed and used in accordance with the instructions, may cause harmful interference to radio communications. However, there is no guarantee that interference will not occur in a particular installation. If this equipment does cause harmful interference to radio or television reception, which can be determined by turning the equipment off and on, the user is encouraged to try to correct the interference by one or more of the following measures:

- Reorient or relocate the receiving antenna.
- Increase the separation between the equipment and receiver.
- Connect the equipment into an outlet on a circuit different from that to which the receiver is connected.
- Consult the dealer or an experienced radio/TV technician for help.

Shielded interface cables must be used in order to comply with emission limits.

Changes or modifications not expressly approved by the party responsible for compliance could void the user's authority to operate the equipment.

INTRODUCTION

Congratulations on your purchase of the Diamond Scan 90e high resolution color monitor. Mitsubishi designed this monitor to provide you with years of reliable trouble-free operation. Once again, thank you for selecting our product and welcome to Mitsubishi!

This guide tells you how to connect, adjust and care for your Diamond Scan 90e monitor. This guide also provides technical specifications and instructions for troubleshooting any basic problems you may experience with your monitor.

1.1 Features

The Diamond Scan 90e is a 49.5cm/19" (46cm/18.0" Diagonal Viewable Image) intelligent, microprocessor-based monitor compatible with most analog RGB (Red, Green, Blue) display standards. It provides crisp text and vivid color graphics with VGA, SVGA, XGA (non-interlaced), and most Macintosh compatible color video cards.

The monitor's wide auto-scanning compatibility range makes it possible to upgrade video cards or software without purchasing a new monitor.

Digitally controlled auto-scanning is done using an internal microprocessor, for horizontal scan frequencies between 30kHz and 95kHz, and vertical scan frequencies between 50Hz and 152Hz. The microprocessor-based intelligence allows the monitor to operate in each frequency mode with the precision of a fixed frequency monitor.

The monitor contains resident memory for pre-programmed screen display standards and is also capable of storing additional user adjustment parameters.

The monitor is capable of producing a maximum horizontal resolution of 1280 dots and a maximum vertical resolution of 1024 lines typically. This display is well suited for windowing environments.

Because of the analog signal inputs, the monitor can display an unlimited palette of colors that can be manually adjusted to suit your specific needs.

The monitor has a power management function accorded to VESA-DPMS-standard. To save energy, the monitor must be connected to a system compliant with the VESA DPMS-standard. (Refer to your computer and/or video card instructions for proper operation.)

To ensure ease of installation and ongoing use, the monitor features More Clear Function and On-Screen Display (OSD) of all monitor set-up and adjustment functions.

For use in a variety of applications, the monitor complies with UL 1950, CSA C22.2 No. 950 and EN60950 for safety, FCC Class-B, VCCI Class II and EN55022 Class-B for EMI, MPR-II, ISO 9241-3 and ISO 9241-8 for ergonomics. The monitor also complies with TCO'95 guideline for environmentally safe use.

Digital Chassis design for lighter, more compact enclosure and increased screen performance.

Short neck (ZENTAN) CRT with 0.25mm pitch shadow mask, advanced-focus DC-DAF (Double Quadrupole-Dynamic Astigmatism and Focus system) electron gun and high contrast optical-quality coating.

The monitor complies with Video Electronics Standards Association (VESA™) DDC1/2B(EDID) specification. If your computer provides DDC1/2B(EDID) function, setup will be done automatically.

1.4 DDC

The monitor includes the DDC1 and DDC2B feature. DDC (Display Data Channel) is a communication channel over which the monitor automatically informs the host system about its capabilities (e.g., each supported resolution with its corresponding timing).

DDC is routed through previously unused pins of the 15-pin VGA connector.

The system will perform "Plug and Play" feature if both, monitor and host, implement the DDC protocol.

1.5 Location Considerations

When setting up and using the monitor, keep the following in mind:

- For optimum viewing, avoid placing the monitor against a bright background or where sunlight or other light sources may reflect on the display area of the monitor; place the monitor just below eye level.
- Place the monitor away from strong magnetic or electromagnetic fields, such as high capacity transformers, electric motors, large current power lines, steel pillars, etc.... Magnetism can cause distortion in the picture and/or color purity.
- Avoid covering the slots or openings of the monitor. Allow adequate ventilation around the monitor so the heat from the monitor can properly dissipate. Avoid putting the monitor into any enclosure that does not have adequate ventilation.
- Avoid exposing the monitor to rain, excessive moisture, or dust, as this can cause a fire or shock hazard.
- Avoid placing the monitor, or any other heavy object, on the power cord. Damage to the power cord can cause a fire or electrical shock.
- When transporting the monitor, handle it with care.

CAUTION

Keep your fingers away from the pivot area of the tilt/swivel base.

1.6 Cleaning Your Monitor

When cleaning the monitor, please follow these guidelines:

- Always unplug the monitor before cleaning.
- Wipe the screen and cabinet front and sides with a soft cloth.
- If the screen requires more than dusting, apply a household window cleaner to a soft cloth to clean the monitor screen.

CAUTION

Do not use benzene, thinner or any volatile substances to clean the unit as the finish may be permanently marked. Never leave the monitor in contact with rubber or vinyl for an extended time period.

1.9 Quick Operation Chart

To summarize the steps in connecting your computer and adapter with Diamond Scan 90e color monitor and setting the necessary controls and switches, refer to the chart below.

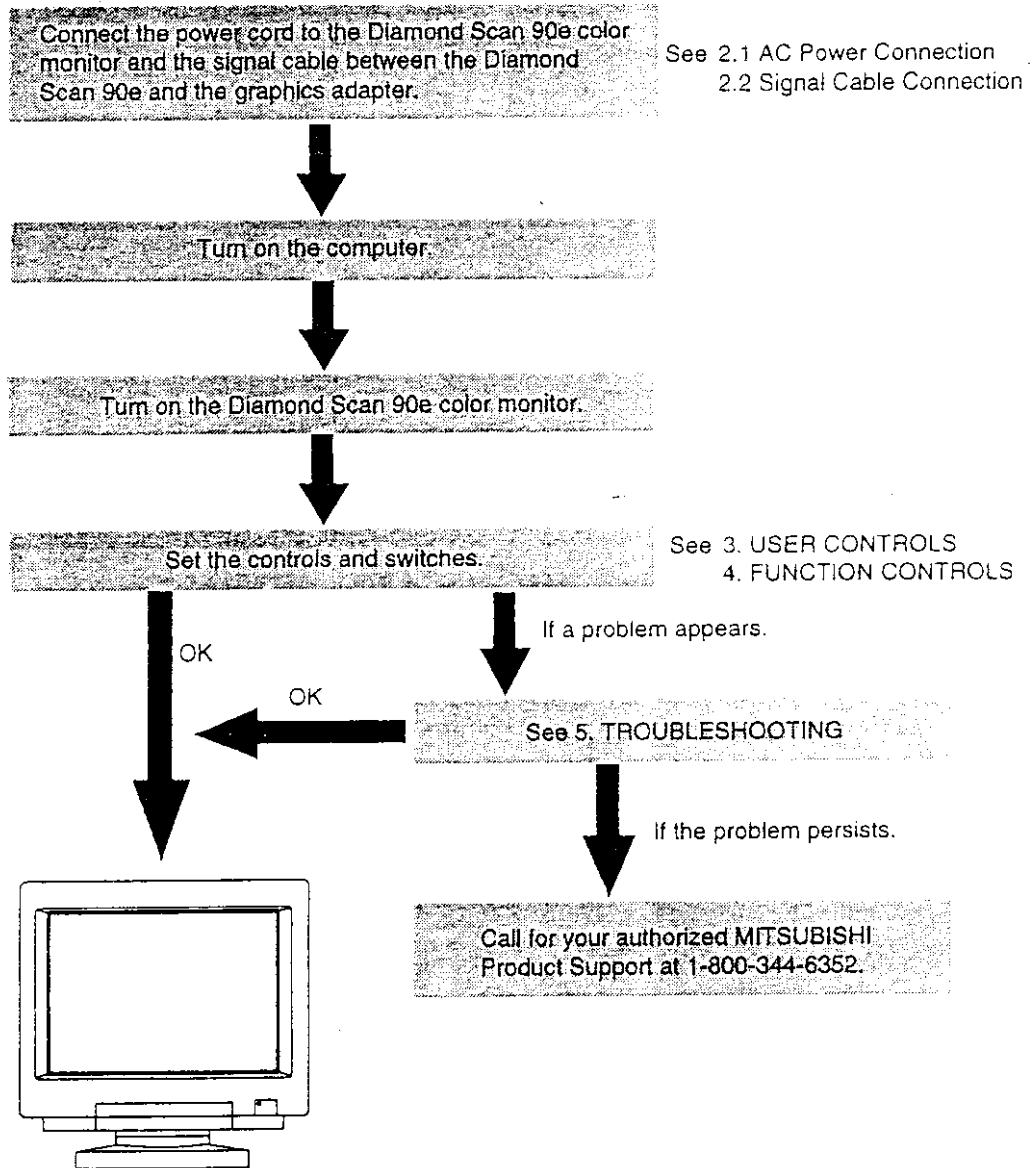



This page is left blank intentionally.

3

USER CONTROLS

3.1 Control Names

See Figure 6 and 7 for the location of the following user controls and indicators. Each control is identified by number and is described individually on page 14.

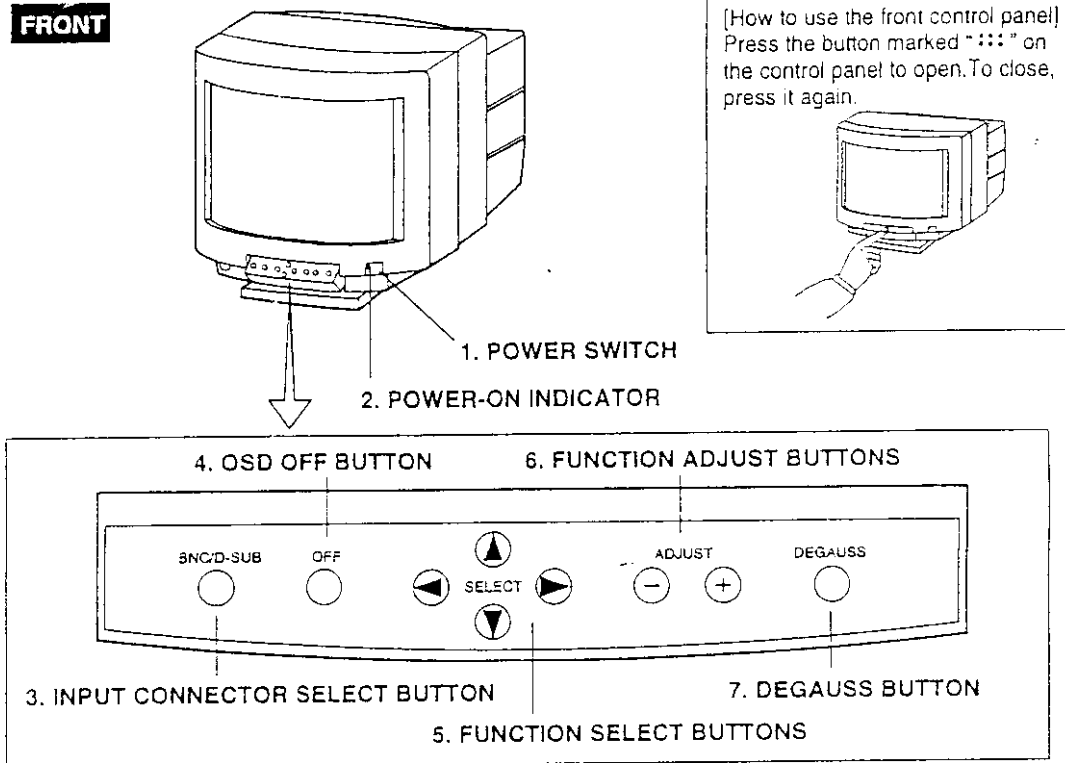

Figure 6

3.2 Function

1. **POWER SWITCH:** A push-on push-off switch for AC power.
2. **POWER-ON INDICATOR:** This indicator illuminates Green when AC power is on or Stand-by mode, and illuminates Amber when suspend or power-off mode.
3. **INPUT CONNECTOR SELECT BUTTON:** Push the BNC/D-SUB button to select the input signal BNC or D-SUB.
4. **OSD OFF BUTTON:** A push type button that is used to turn off the OSD.
5. **FUNCTION SELECT BUTTONS:** Push the select buttons to choose one of the functions that is superimposed on the display screen.
6. **FUNCTION ADJUST BUTTONS:** Push the adjust buttons to adjust the image on the screen that is selected via the function select buttons.
7. **DEGAUSS BUTTON:** A push type button that is used to eliminate possible color shading or impurity.

REAR

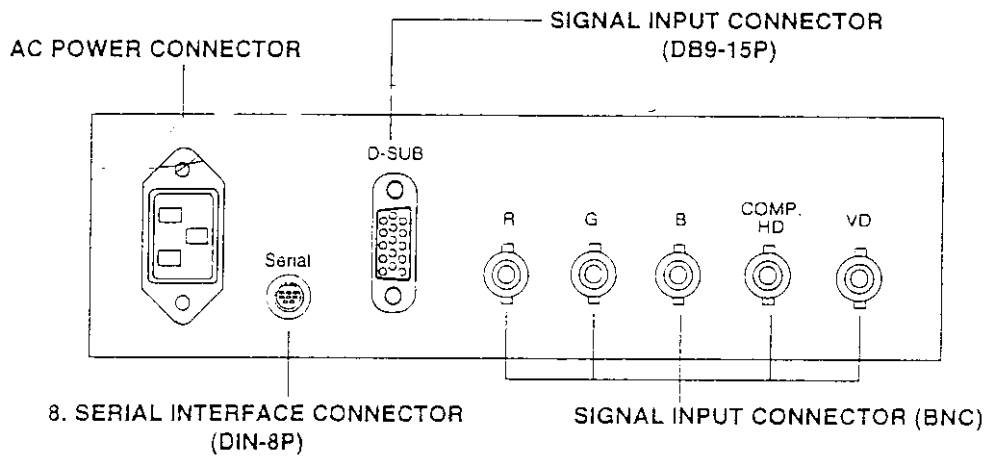
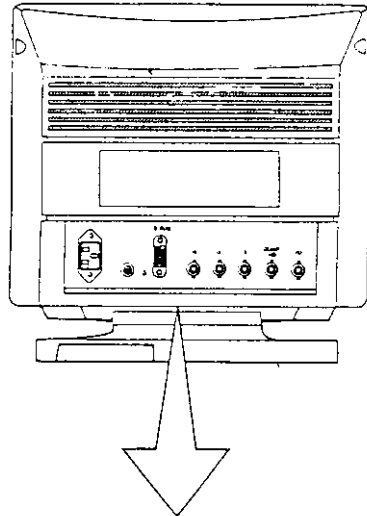

Figure 7

8. **SERIAL INTERFACE CONNECTOR:** The monitor has a DIN-8P connector for serial interface communication.

4.1 Operation

Press any select button and control indicators will be superimposed on the display screen called 1st layer.







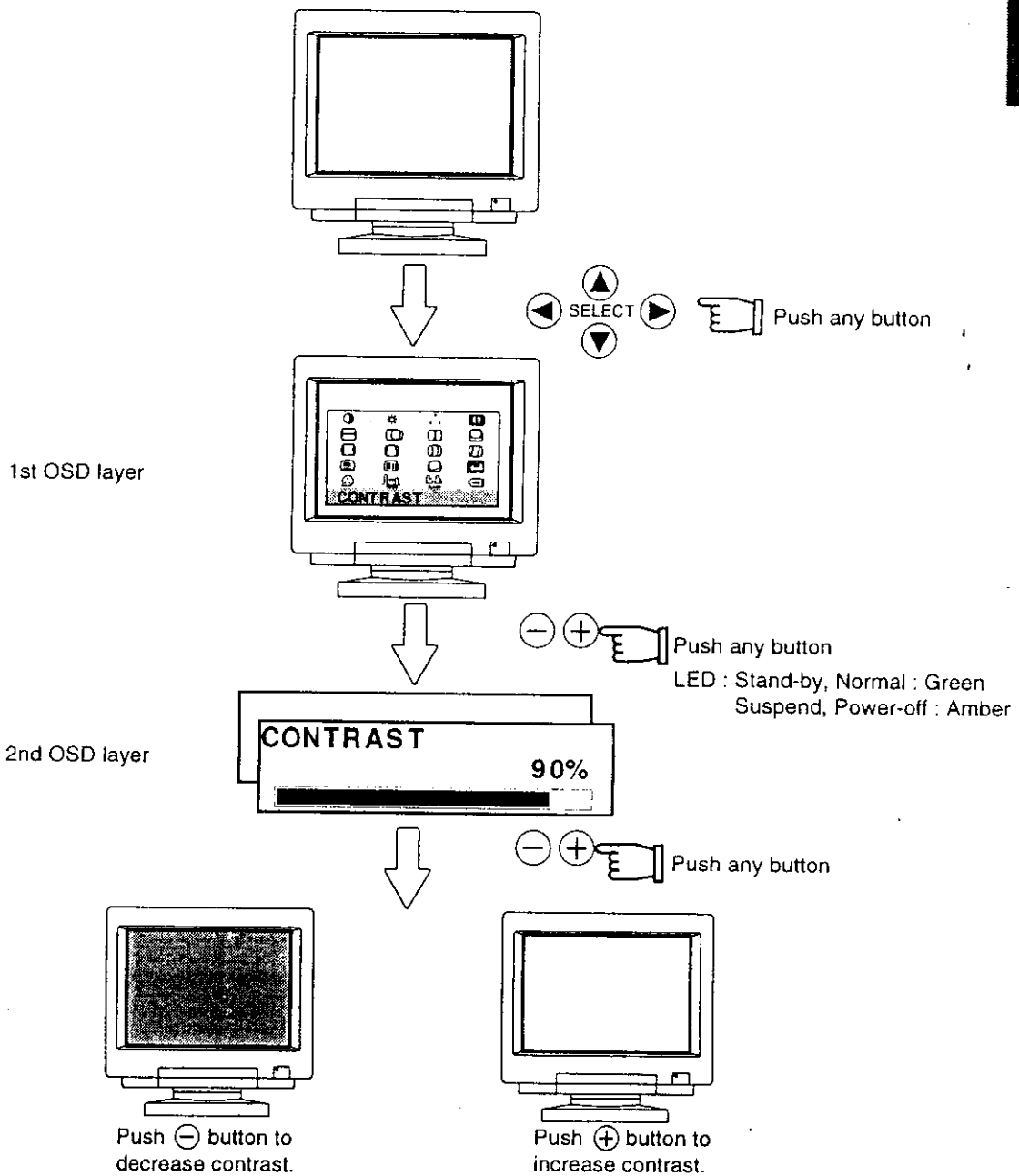

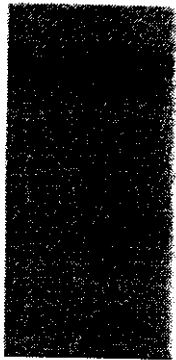





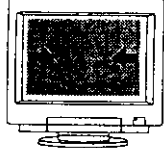
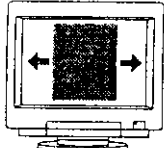

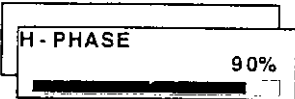
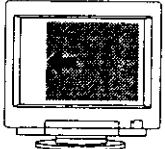
Refer to Figure 6 for the location of the monitor function (◀ ▶ ▲ ▼) controls. Press the select buttons to choose one of the following controls.

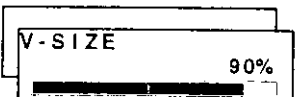
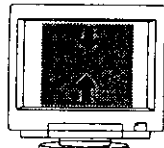
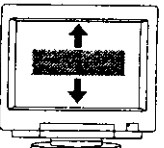





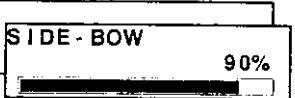

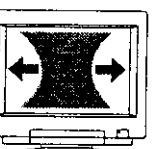

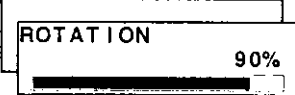
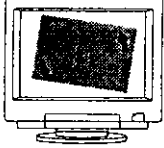
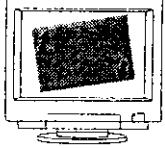

The indication of a function symbol changes to blue.

When selected the function symbol of above OSD, press the adjust button (⊕ or ⊖), the OSD screen changes to following called 2nd layer. Then you can adjust each function by ⊕ ⊖ buttons.

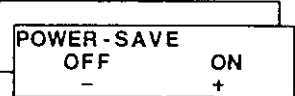

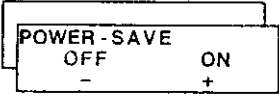

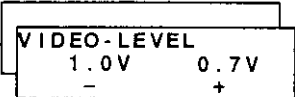
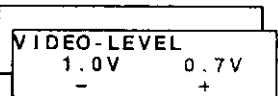
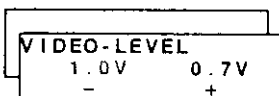
Symbol of 1st OSD layer	2nd OSD layer	Press the Minus Adjust Button: 	Press the Plus Adjust Button: 
⑤ H-SIZE 	 LEVEL: 00 - 100%	 To narrow the width of the image on the screen.	 To expand the width of the image on the screen.
⑥ H-PHASE 	 LEVEL: 00 - 100%	 To move the image to the left.	 To move the image to the right.
⑦ V-SIZE 	 LEVEL: 00 - 100%	 To narrow the height of the image on the screen.	 To expand the height of the image on the screen.
⑧ V-POSITION 	 LEVEL: 00 - 100%	 To move the image down.	 To move the image up.
⑨ SIDE-BOW 	 LEVEL: 00 - 100%	 To collapse the center of the image.	 To expand the center of the image.

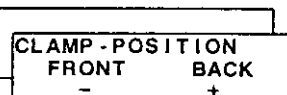
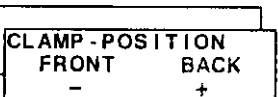
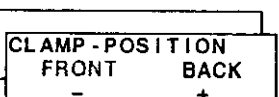
Symbol of 1st OSD layer	2nd OSD layer	Press the Minus Adjust Button: 	Press the Plus Adjust Button: 
⑮ ROTATION 	 LEVEL: 00 - 100%	 To rotate to the left. Press plus and minus buttons together, to restore to factory preset level.	 To rotate to the right.
⑯ GEOMETRY RESET 		To cancel the geometry reset operation.	To reset the geometry data to factory adjusted condition. 
⑰ POWER-SAVE 		To select the constant power-on mode. 	To select the power-save mode. 
⑱ VIDEO-LEVEL 		To select 1.0V of video input. 	To select 0.7V of video input. 
⑲ CLAMP-POSITION 		To clamp the video signal at the front of the H-Sync pulse. 	To clamp the video signal at the back of the H-Sync pulse. 

4.2 POWER SAVE

NOTE

When the monitor has no sync signal or incorrect connection and the signal frequency is out of range, the following CAUTION comes on the screen. Check input signal, signal cable connection and signal frequency.

1. POWER SAVE IS OFF

When POWER SAVE is OFF and there is no sync signal, the following screen is displayed.

**ATTENTION
NO SIGNAL
PLEASE CHECK
INPUT SIGNAL OR
CONNECTION.**

2. POWER SAVE IS ON

(1) When POWER SAVE is ON and there is no sync signal, the following screen is displayed for 5 seconds.

**ATTENTION
NO SIGNAL
PLEASE CHECK
INPUT SIGNAL OR
CONNECTION.**

(2) Before 2 seconds POWER SAVE function works, the following screen is displayed. The power on indicator illuminates to change Amber.

POWER SAVE

3. POWER SAVE IS ON OR OFF

When signal frequency is out of range, the following screen(ex. 96.8kHz/73Hz timing input) is displayed.

**ATTENTION
SIGNAL FREQUENCY
IS OUT OF RANGE.
PLEASE CHANGE
SIGNAL TIMING.**

6

SPECIFICATIONS

CRT	Size	49.5cm/19" (46cm/18" Diagonal Viewable Image)	
	Mask type	SHADOW MASK	
	Gun	In-line	
	Deflection angle	100°	
	Phosphors	Red, Green, Blue EBU (medium short persistence) Crystal pigment	
	Dot pitch	0.25mm	
	Face Plate	Anti-glare, Anti-reflection and Anti-static coating	
	Focusing method	Double Quadrupole-Dynamic Astigmatism and Focus system(DQ-DAF)	
INPUT SIGNAL	Video	0.7 and 1.0Vp-p analog RGB	
	Sync	Sync. on Green or separated H, V sync. or Composite sync	
INTERFACE	Input Connector	5BNC, DB9-15P, DIN-8P(for USB kit)	
	Input Impedance	75Ω (video), 1kΩ (sync)	
SCANNING FREQUENCY	Horizontal	31.5-91KHz	
	Vertical	60-85Hz.	
RESOLUTION (HxV)	1280 x 1024 Non-interlaced maximum addressable resolution format at 75Hz		
WARM-UP TIME	30 minutes to reach optimum performance level		
BRIGHTNESS	≥ 100cd/ m ² , standard full white video signal		
VIDEO AMPLIFIER	50Hz - 150MHz (typ.)		
BLANKING TIME	Horizontal	≥ 2.3 μsec (typ.)	
	Vertical	≥ 500 μsec (typ.)	
DISPLAY SIZE	340mm x 255mm (typ.)	ratio 4:3, e.g. 1600dots x 1200lines	
COLOR	5000 - 9950K		
POWER SOURCE	AC100-240V±10% 50/60Hz 150W (typ.) < 130W (typ.: without USB-Unit KT-X406) >		
OPERATING ENVIRONMENT	Temperature	5 - 35°C	
	Humidity	10 - 90%RH (without condensation)	
CABINET	(W)18.5inch x (H)18.5inch x (D)16.1inch (W)470mm x (H)468mm x (D)408 mm		
WEIGHT	2.5kg (49.6lbs.)		
TILT/SWIVEL BASE	Tilt Angle	-5° - +10°	
REGULATIONS	Swivel Angle	±45°	
	Safety	UL1950 (UL), CSA C22.2 No.950 (C-UL) EN60950 (TÜV-GS)	
	EMC	FCC Class-B, DOC Class-B EN55022 Class-B, VCCI Class-2 EN50082-1, EN61000-3-2	
	X-Ray	DHHS, HWC Röv vom 8.1, 1987	
	Other	CE-Marking, MPR-II ISO 9241-3, ISO 9241-8 (TÜV-ERGO) TCO '95 ZH1/618 (TÜV-GS) International Energy Star Program Guidelines for the Suppression of Harmonics in Appliances and General-Use Equipment	

7.3 SC-B102 Signal Cable

PIN ASSIGNMENT AND SIGNAL LEVEL

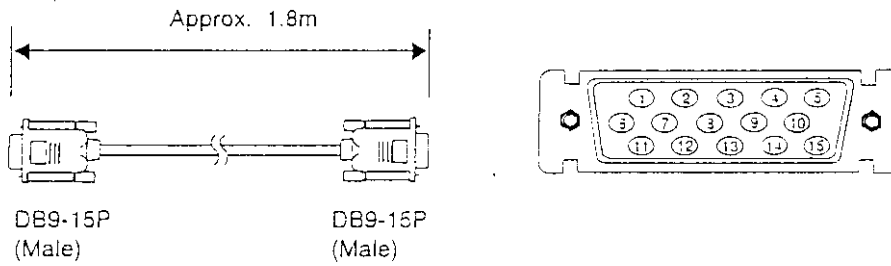

Wire : 5 coaxial

PIN ASSIGNMENT \ SIGNAL	ANALOG
1	RED
2	GREEN
3	BLUE
4	GROUND
5	DDC GROUND
6	RED GROUND
7	GREEN GROUND
8	BLUE GROUND
9	NC
10	SYNC GROUND
11	GROUND
12	SDA
13	HORIZONTAL SYNC
14	VERTICAL SYNC(VCLK)
15	SCL

SIGNAL LEVEL
 NC NO-CONNECTION
 DDC: DISPLAY DATA CHANNEL
 SDA: SERIAL DATA
 SCL: SERIAL CLOCK

7

APPENDIX

7.1 Monitor Signal Input Connector (DB9-15P)

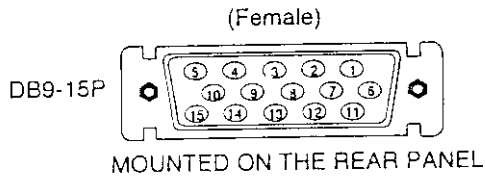

DDC DISPLAY DATA CHANNEL
 SDA SERIAL DATA
 SCL SERIAL CLOCK
 NC NO-CONNECTION

PIN ASSIGNMENT

Pin No.	Signal
1	RED VIDEO
2	GREEN VIDEO or COMPOSITE SYNC with GREEN VIDEO
3	BLUE VIDEO
4	GROUND
5	DDC GROUND
6	RED GROUND
7	GREEN GROUND
8	BLUE GROUND
9	NC
10	SYNC GROUND
11	GROUND
12	SDA
13	HORIZONTAL SYNC or COMPOSITE SYNC
14	VERTICAL SYNC(VCLK)
15	SCL

7.2 Serial Interface Input Connector (DIN-8P) For Serial Interface Function

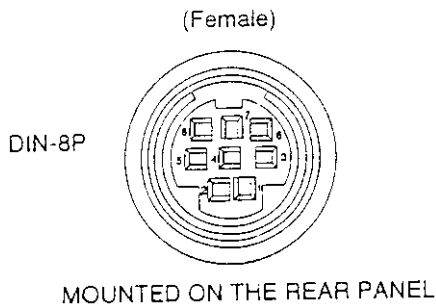

PIN ASSIGNMENT

Pin No.	Signal
1	DTR (Data Terminal Ready)
2	NC
3	TXD (Transmitted Data)
4	GND
5	RXD (Receive Data)
6	GND
7	NC
8	NC

NC..... NO-CONNECTION

5

TROUBLESHOOTING

Before calling your Authorized Product Support, please check that the items below are properly connected or set.

In case of using a non-standard signal, please check the pin assignments and the signal timing of your computer with the specification outlined in SPECIFICATION 6 and APPENDIX 7.

PROBLEM		ITEMS TO CHECK	LOCATION
No picture	LED On-Green	<ul style="list-style-type: none"> • Contrast and brightness controls. 	<ul style="list-style-type: none"> • Front (Adjust to the maximum brightness or push the reset button)
	LED Off	<ul style="list-style-type: none"> • Power switch. • AC power cord disconnected. 	<ul style="list-style-type: none"> • Front • Rear
	LED On-Amber	<ul style="list-style-type: none"> • Signal cable disconnected. • BNC cables are misconnected or the green cable is disconnected. • Computer power switch. • Power management function is active. 	<ul style="list-style-type: none"> • Rear • Check the graphics adapter and cables • Computer • Check the power management function. (see P25)
Abnormal picture	Un-stable picture	<ul style="list-style-type: none"> • BNC cables are misconnected. • Input signal frequency range is disagreement. CGA MODE is not available. MDA MODE is not available. EGA MODE is not available. 	<ul style="list-style-type: none"> • Rear • Check the specification of graphics adapter and monitor
	No green color with BNC	<ul style="list-style-type: none"> • BNC cables are misconnected. (Green and composite sync. connection is reversed) 	<ul style="list-style-type: none"> • Rear
Display is missing, center shifts, or too small or too large of a display size		<ul style="list-style-type: none"> • Adjust H.SIZE, V.SIZE, H.PHASE, and V.POSITION with non-standard signals • Monitor may not be able to get full-screen image depend on signal. In this case, please select other resolution, or other vertical refresh timing. • Make sure you wait a few seconds after adjusting the size of the image before changing or disconnecting the signal or powering OFF the monitor. 	<ul style="list-style-type: none"> • Front (OSD) • Front (OSD)
Display is not stable		<ul style="list-style-type: none"> • BNC cables are misconnected. 	<ul style="list-style-type: none"> • Rear
Display is dark or too bright		<ul style="list-style-type: none"> • Input video signal level select is not at the appropriate position for your graphics adapter output.(0.7V or 1.0Vp-p) 	<ul style="list-style-type: none"> • Front (OSD)

Symbol of 1st OSD layer	2nd OSD layer	Press the Minus Adjust Button:	Press the Plus Adjust Button:
⑳ USB PORT SELECT 	<div style="border: 1px solid black; padding: 5px; text-align: center;"> USB STATUS PLEASE CHECK MONITOR CONNECTION OR USB IS SUSPENDED </div>	<p>This "USB PORT SELECT" is prepared for optional part "USB-unit KT-X406" installed only.</p> <p>Attention OSD screen is displayed without USB unit.</p> <p>For installing USB-unit, please read the manual of USB kit.</p>	

㉑ ADJUST LOCK

1. Press the right of select button and minus of adjust button together, the "ADJUST LOCK" screen appears.

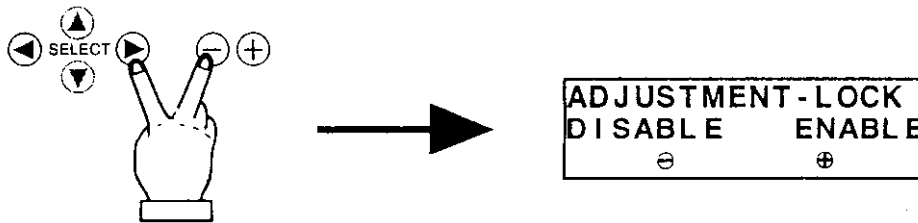







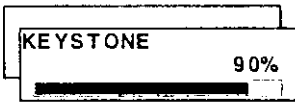
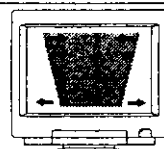
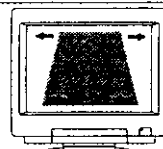

2. Press the plus button to lock on the OSD, and "LOCKED" character is indicated on 1st layer. You can operate OSD menu only CONTRAST, BRIGHTNESS and INFORMATION.

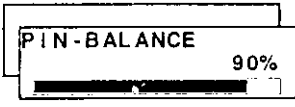
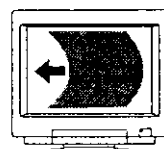
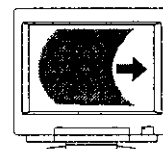

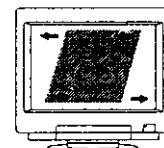

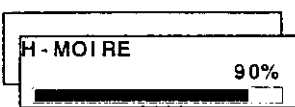

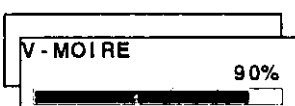

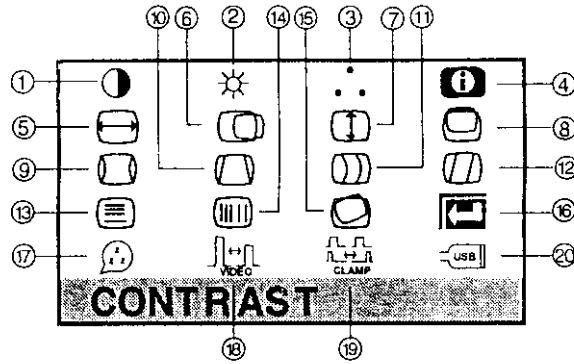

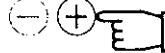

3. Press the minus button to lock off the OSD. You can operate OSD and all can be selected menu again.

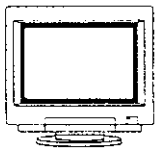

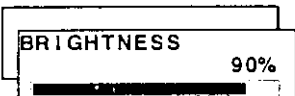
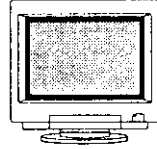
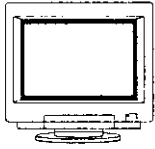
Symbol of 1st OSD layer	2nd OSD layer	Press the Minus Adjust Button:	Press the Plus Adjust Button:
⑩ 	 LEVEL: 00 - 100%	 The decrease the width at the top of the screen image and to increase the width at the bottom.	 The increase the width at the top of the screen image and to decrease the width at the bottom.
⑪ 	 LEVEL: 00 - 100%	 To move the top and bottom of the screen image to the right.	 To move the top and bottom of the screen image to the left.
⑫ 	 LEVEL: 00 - 100%	 To make the screen slant to the left.	 To make the screen slant to the right.
⑬ 	 LEVEL: 00 - 100%	Press the plus or minus button to decrease the level of the horizontal moire wave. Press plus and minus buttons together, to restore to factory preset level.	
⑭ 	 LEVEL: 00 - 100%	Press the plus or minus button to decrease the level of the vertical moire wave. Press plus and minus buttons together, to restore to factory preset level.	

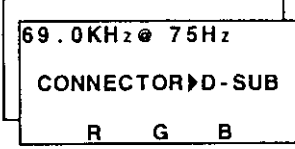

Symbol of 1st OSD layer	2nd OSD layer	Press the Minus Adjust Button: 	Press the Plus Adjust Button: 
① CONTRAST 	 LEVEL: 00 - 100%	 To decrease the contrast. Press plus and minus buttons together, to restore to factory preset level.	 To increase the contrast.
② BRIGHTNESS 	 LEVEL: 00 - 100%	 To decrease the brightness. Press plus and minus buttons together, to restore to factory preset level.	 To increase the brightness.
③ COLOR TEMPERATURE 	 LEVEL: 5000 - 9950K	To increase the red color level. Data indicates color temperature (k:kelvin)	To increase the blue color level.
④ INFORMATION 		<ul style="list-style-type: none"> • Indicate the horizontal frequency and the vertical frequency of input signal. • Indicate input connector. 	

4

OSD(On Screen Display) FUNCTIONS

- (1) **CONTRAST:** Adjusts to the desired contrast level.
- (2) **BRIGHTNESS:** Adjusts to the black level of the screen.
- (3) **COLOR-TEMPERATURE:** Adjusts the color temperature of the screen image.
- (4) **INFORMATION:** Indicate current,Screening frequency and Input Video signal port (signal connector)
- (5) **H-SIZE (Horizontal Size):** Controls the horizontal size of the image on the screen.
- (6) **H-PHASE (Horizontal Position):** Controls the horizontal position of the image on the screen.
- (7) **V-SIZE (Vertical Size):** Controls the vertical size of the image on the screen.
- (8) **V-POSITION (Vertical Position):** Controls the vertical position of the image on the screen.
- (9) **SIDE-BOW (Pincushion or Bow Amplitude):** Straightens the left and right sides of the screen image.
- (10) **KEY STONE:** Adjusts the parallelism of the left and right sides of the screen image.
- (11) **PIN-BALANCE:** Adjusts the curvature of the left and right sides of the screen image.
- (12) **KEY-BALANCE:** Adjusts the vertical slant or tilt of the screen image.
- (13) **H-MOIRE:** Adjusts the horizontal moire level on the screen.
- (14) **V-MOIRE:** Adjusts the vertical moire level on the screen.
- (15) **ROTATION:** Adjusts the rotation or twist of the picture.
- (16) **GEOMETRY-RESET:** Restore to factory preset following mode; H-SIZE, H-PHASE, V-SIZE, V-POS, SIDE-BOW, KEY STONE, PIN-BALANCE, KEY-BALANCE.
- (17) **POWER-SAVE (ON/OFF):** When adjusting ON, reduces the power consumption of the monitor when not in use.
- (18) **VIDEO LEVEL:** Selects video levels 1.0V or 0.7V.
- (19) **CLAMP-POSITION:** Use this function to eliminate excessive green or white background that may occur when both Sync-On-Green and external sync signals are applied to the monitor.
- (20) **USB PORT SELECT:** Control upstream connection with using optional USB unit KT-X406.

This page is left blank intentionally.

BNC CONNECTION

- (1) IN CASE OF A COMPOSITE SYNC ON GREEN VIDEO SIGNAL (SYNC ON GREEN):
Connect the R, G and B video signals to the BNC receptacles on the back of the monitor.

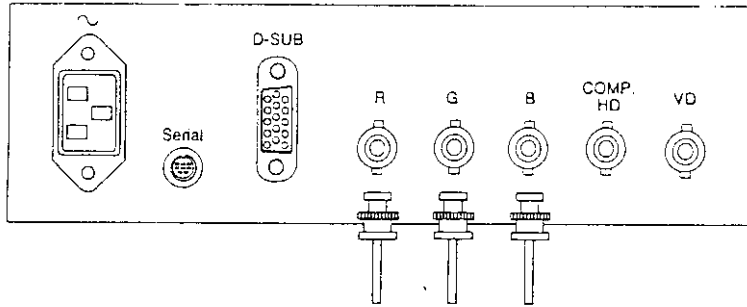

- (2) IN CASE OF EXTERNAL COMPOSITE SYNC SIGNAL:
Connect the R, G and B video signals and the Composite sync signal to BNC receptacles on rear panel, respectively.

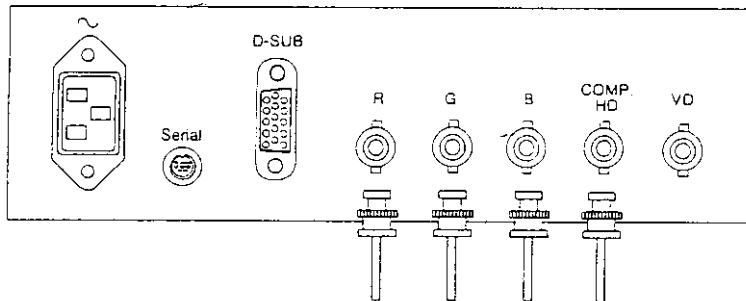

- (3) IN CASE OF SEPARATE HORIZONTAL AND VERTICAL SYNC SIGNALS:
Connect the R, G and B video signals and the horizontal and vertical sync signals to the BNC receptacles on the rear panel.

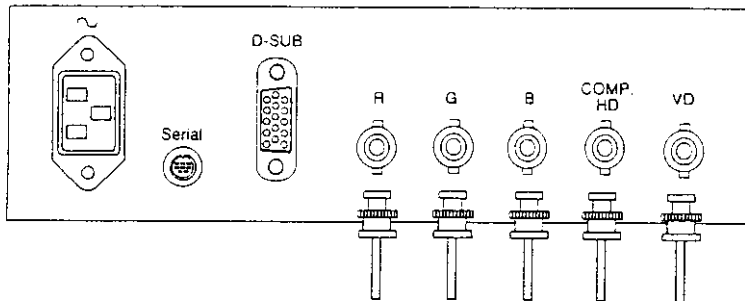

2

CONNECTING THE MONITOR

On the back of the monitor are four plug-in connections: one for the AC power cord, DB9-15P connector, BNC connector for video and a DIN-8P connector for the optional USB-unit.

2.1 AC Power Connection

One end of the AC power cord is connected into the AC power connector on the back of the monitor. The other end is plugged into a properly grounded three-prong AC outlet. The monitor's auto-sensing power supply can automatically respond to the power supply input of 100-240V AC and 50/60Hz.

2.2 Signal Cable Connection

The attached video signal cable provides a DB9-15P connector for the VGA compatible analog RGB outputs on your computer. The RGB signal may be derived from an IBM® PS/2, or compatible Apple Macintosh built-in video. Most third party color cards can also be interfaced using the free Mitsubishi Apple adaptor available from your dealer.

2.2.1 Connecting to Any IBM VGA Compatible System

Figure 3 shows the SC-B102 cable connection to the Video Graphics Array (VGA) port in an IBM Personal System/2® Model 50, 60, 70 and 80, or any VGA compatible system.

1. Power off, the monitor and the computer.
2. Connect the one end of the SC-B102 cable to the DB9-15P connector on the VGA controller card.
3. Connect the other end of the SC-B102 cable to the DB9-15P receptacle on the back of the monitor.
4. Power on the computer, then the monitor.
5. After using the system, power off the monitor, then the computer.

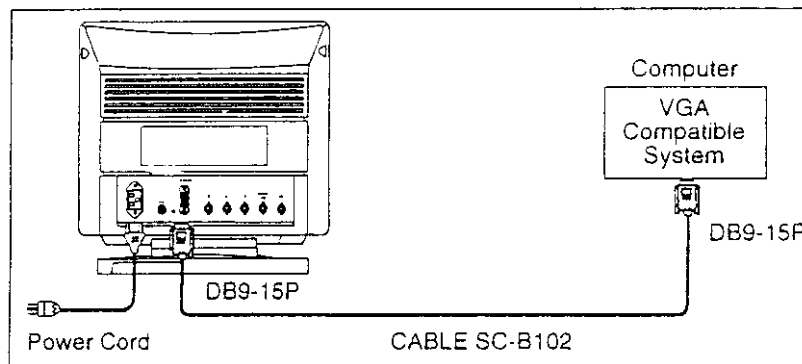

Figure 3.

CAUTION

The socket-outlet shall be installed near the equipment and shall be easily accessible. During servicing, disconnect the plug from the socket-outlet.

Même si le moniteur est mis hors tension il reste toujours alimenté. La prise secteur devrait ainsi être facilement accessible en cas d'urgence.



1.7 Unpacking

After you unpack the box you should have all of the items indicated in Figure 1. Save the box and packing materials in case you ship or transport the monitor. Complete and mail in warranty cards.

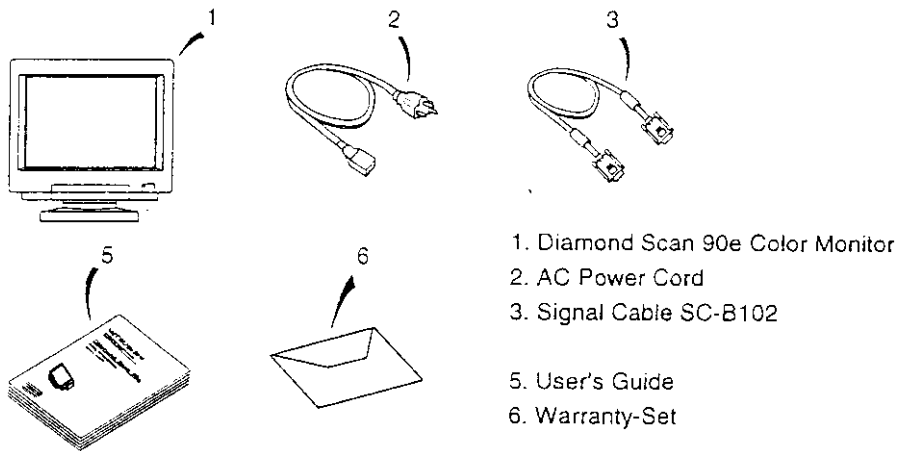

Figure 1.

1.8 Tilt/Swivel Base

The monitor comes with a tilt/swivel base. This enables you to position the monitor to the best angle and tilt for maximum viewing comfort.

Screen Position Adjustment

Adjust the tilt and rotation of the monitor by placing your hands at opposite sides of the case, as shown in Figure 2. You can adjust the monitor 45 degrees right or left, 15 degrees up or 5 degrees down, as shown below.

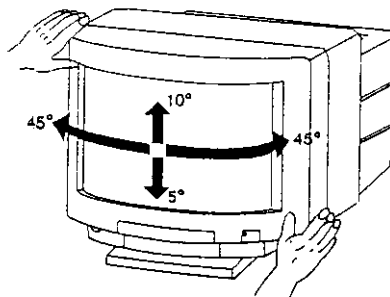

Figure 2.

- **Power-off mode**
 When the horizontal sync signal and vertical sync signal are off, after about 10 seconds the monitor is switched to a power-off mode, which reduces the monitor power consumption to less than the power consumed at suspend mode above.
 When the monitor is in power-off mode, the screen is off, and the power indicator will change to amber. After both the sync signals are restored, picture will be displayed within several seconds.
- **Suspend mode**
 When the vertical sync signal is off, after about 10 seconds the monitor is switched to a suspend mode which reduces the monitor power consumption to less than 15W.
 When the monitor is in suspend mode, the screen is off and the power indicator will change to amber. After the vertical sync signal is restored, picture will be displayed within a few seconds.
- **Stand-by mode**
 When the horizontal sync signal is off after about 10 seconds, the monitor is switched to a stand-by mode. When the monitor is in stand-by mode, the screen is off.
 After the horizontal sync signal is restored, picture will be displayed immediately.

The monitor has the power management function which reduces the power consumption of the monitor when not in use. There are three reduced power level modes.

1.3 Power Management Function

Resolution	Fh (KHz)	Fv (Hz)	Polarity	
			H	V
640 x 480 N.I.	31.5	60.0	-	-
640 x 480 N.I.	37.5	75.0	-	-
800 x 600 N.I.	46.9	75.0	+	+
1024 x 768 N.I.	60.0	75.0	+	+
1152 x 870 N.I.	68.7	75.1	-	-
1280 x 1024 N.I.	80.0	75.0	+	+
1280 x 1024 N.I.	91.1	85	+	+

Table 1. Memory Buffer Factory Presets

To minimize adjustment needs, the factory has preset popular display standards into the monitor, as shown in Table 1. If any of these display standards are detected, the picture size and centering are automatically adjusted. All of the factory presets may be overwritten by adjusting the user controls. The monitor is capable of automatically storing up to 10 additional display standards. The new display information must differ from any of the existing display standards by at least 1KHz for the horizontal scan frequency or 5Hz for the vertical scan frequency or the sync signal polarities must be different.

1.2 Internal Preset Memory Capability

CONTENTS

1. INTRODUCTION	6
1.1 Features	6
1.2 Internal Preset Memory Capability	7
1.3 Power Management Function	7
1.4 DDC	8
1.5 Location Considerations	8
1.6 Cleaning Your Monitor	8
1.7 Unpacking	9
1.8 Tilt/Swivel Base	9
Screen Position Adjustment	9
1.9 Quick Operation Chart	10
2. CONNECTING THE MONITOR	11
2.1 AC Power Connection	11
2.2 Signal Cable Connection	11
2.2.1 Connecting to Any IBM VGA Compatible System	11
3. USER CONTROLS	14
3.1 Control Names	14
3.2 Function	14
4. OSD(On Screen Display) FUNCTIONS	16
4.1 Operation	17
4.2 POWER SAVE	23
5. TROUBLESHOOTING	24
6. SPECIFICATIONS	25
7. APPENDIX	26
7.1 Monitor Signal Input Connector (DB9-15P)	26
7.2 Serial Interface Input Connector (DIN-8P) For Serial Interface Function ..	26
7.3 SC-B102 Signal Cable	27

Note : This manual is designed for use with Diamond Scan 90e color display monitor.

In and after the middle of this page, you will find a brief summary of the environmental requirements met by this product. The complete environmental criteria document may be ordered from:

TCO Development Unit
S-114 94 Stockholm
Sweden

Fax: +46 8 782 92 07

E-mail (Internet): development@tco.se

Current information regarding TCO'95 approved and labelled products may also be obtained via the Internet, using the address:

<http://www.tco-info.com/>

TCO'95 is a co-operative project between



Environmental Requirements

Brominated flame retardants are present in printed circuit boards, cabling, casings and housings, and are added to delay the spread of fire. Up to 30 % of the plastic in a computer casing can consist of flame-retardant substances. These are related to another group of environmental toxins, PCB, and are suspected of giving rise to similar harm, including reproductive damage in fish-eating birds and mammals. Flame retardants have been found in human blood and researchers fear that they can disturb foetus development. Bio-accumulative* TCO'95 demands require that plastic components weighing more than 25 grammes must not contain flame retardants with organically bound chlorine or bromine.

Lead

can be found in picture tubes, display screens, solder and capacitors. Lead damages the nervous system and in higher doses, causes lead poisoning. The relevant bio-accumulative* TCO'95 requirement permits the inclusion of lead, as no replacement has yet been developed.

Cadmium

is present in rechargeable batteries and in the colour-generating layers of certain computer displays. Cadmium damages the nervous system and is toxic in high doses. The relevant bio-accumulative* TCO'95 requirement states that batteries may not contain more than 25 ppm (parts per million) of cadmium. The colour-generating layers of display screens must not contain any cadmium.

Mercury

is sometimes found in batteries, relays and switches. Mercury damages the nervous system and is toxic in high doses. The relevant bio-accumulative* TCO'95 requirement states that batteries may not contain more than 25 ppm (part per million) of mercury.

demands require that no mercury is present in any of the electrical or electronic components concerned with the display unit.

CFCs (freons) are sometimes used for washing printed circuit boards and in the manufacture of expanded foam for packaging. CFCs break down ozone and thereby damage the ozone layer in the stratosphere, causing increased reception on Earth of ultra-violet light with consequent increased risks of skin cancer (malignant melanoma). The relevant TCO'95 requirement: Neither CFCs nor HCFCs may be used during manufacture of the product or its packaging.

* Bio-accumulative is defined as substances which accumulate within living organisms.