

# Installation and Operation Manual

## Delta Distributed Power Information Collector



Before you use this equipment, please read this important operation manual.

Dear Customer,

Thank you for choosing the Delta Distributed Power Information Collector. This device is a part of the Delta Solar Energy Monitoring System (EMS). With this device, you can monitor Delta PV micro inverters that are connected to the photovoltaic modules. The DDP collects energy and performance data from the PV micro inverter over in-home AC power lines. It then forwards that data to Delta Solar EMS via the Internet for statistical reporting, analysis, and storing.

Before you use this equipment, please read this important operation manual. Should you have any questions, please do not hesitate to contact your dealer for further assistance.

It is our pleasure to have you as our customer.

## **Federal Communication Commission Interference Statement**

This device complies Part 15 of the FCC Rules. Operation is subject to the following two conditions: (1) This device may not cause harmful interference, and (2) this device must accept interference received, including interference that may cause undesired operation.

This equipment has been tested and found to comply with the limits for a Class B digital device, pursuant to part 15 of the FCC Rules. These limits are designed to provide reasonable protection against harmful interference in a residential installation. This equipment generates, uses and can radiate radio frequency energy and, if not installed and used in accordance with the instructions, may cause harmful interference to radio communications. However, there is no guarantee that interference will not occur in a particular installation. If this equipment does cause harmful interference to radio or television reception, which can be determined by turning the equipment off and on, the user is encouraged to try to correct the interference by one of the following measures:

- Reorient or relocate the receiving antenna.
- Increase the separation between the equipment and the receiver.
- Connect the equipment into an outlet on a circuit different from that to which the receiver is connected.
- Consult the dealer or an experienced radio/TV technician for help.

FCC Caution: Any changes or modifications not expressly approved by the party responsible for compliance could void the user's authority to operate this equipment.

This transmitter must not be co-located or operating in conjunction with any other antenna or transmitter.

### **Radiation Exposure Statement:**

This equipment complies with FCC radiation exposure limits set forth for an uncontrolled environment. This equipment should be installed and operated with minimum distance 20cm between the radiator & your body.

Note: The country code selection is for non-US model only and is not available to all US model. Per FCC regulation, all WiFi product marketed in US must fixed to US operation channels only.

Pursuant to IEC60950, the Data Collector involves technologies and materials or methods provide a level of safety. Any modifications or changes made to this equipment may void the user warranty.

## Table of Contents

1. <b>DDP Function</b> .....	4
2. <b>DDP Installation</b> .....	5
Preparation.....	5
Installation .....	5
For US Users .....	6
For European Users .....	7
Wall Mounting .....	7
Relocating the DDP.....	10
3. <b>DDP Operation</b> .....	11
Starting the DDP.....	11
DDP Menu.....	12
Interface Screen.....	13
Other Screen.....	14
System Screen.....	14
Restart the DDP.....	17
Normal Operation.....	17
4. <b>Troubleshooting</b> .....	19
Potential Problems and Solutions.....	19
5. <b>DDP Internet Interface</b> .....	20
Login and Register Screen with Connect to Internet.....	20
Monitor with no Internet.....	29
User Host with Connect to Internet.....	31
Event Message.....	32
6. <b>Technical Data</b> .....	34

## 1. DDP Function

The **DDP information collector** is a device for Delta Solar Energy Monitor System to communicate with Delta PV micro inverter. This device monitors Delta PV micro inverters that are connected to the photovoltaic modules. The DDP collects energy and performance data from the PV micro inverter over in-home AC power lines and forwards that data to the Delta Solar EMS via the Internet for statistical reporting.

The **Delta PV Micro Inverter** system is a device that converts the solar panel DC output into grid-compliant AC power. This fully integrated device can maximize the modules' energy production by utilizing a sophisticated Maximum Power Point Tracking (MPPT) algorithm. This integrated system maximizes energy harvest and provides individual AC output without hazardous voltage. And in case of any failure of any individual solar panel or inverter, this will not impact other modules and inverter operations. Unlike traditional center inverter structures, this PV micro inverter system provides true redundancy and eliminates hazardous voltage levels.

The **Delta Solar EMS** collects and analyzes the per-module data from each PV micro inverter.

This system automatically detects any shortfall in energy production. It is easy for a repair technician to locate the failed solar module and perform the necessary replacement. It monitors and stores data on a constant basis. User can access the data for commercial or personal use.

The DDP is designed for easy installation and is easy to operate. User does not need any specialized equipment. It simply plugs to the grid tied wall AC outlet and routers for communications with the Delta Solar EMS. The DDP communicates with the individual PV micro inverters over the existing power lines in the residence or business.

After installation and device scanning, it assembles an internal database of all known Delta PV micro inverters at the site it manages. As a constant monitor, the DDP utilizes the customer's site broadband router to forward information to the Delta Solar EMS. The DDP also reports any error conditions that affect the DDP or the PV micro inverters. You can view both energy data and error conditions in the Delta Solar EMS.

## 2. DDP Installation

### Preparation

Before you install this device, first please check if the following items are included in the DDP package box. If there is any item missing, please contact your dealer for a free replacement:

- DDP Communications
- Ethernet cable
- Wi-Fi antenna
- AC power cord
- A kit of conical anchors and screws
- Wall bracket
- User manual

The following networking environment is required for install DDP:

- A reliable broadband internet connection
- Web browser to view **DELTA Solar EMS** webpage
- Router / LAN or Router/WLAN with Ethernet port (or AP Router with Wi-Fi connection)
- Grid connected standard AC electrical outlet. Please do not plug DDP into a transformer protection device like a power strip, surge protector, or un-interruptible power supply. These devices could block the communication signal.

### Installation

Pick a suitable location to place your DDP device. We suggest this location to be as close as possible to the wireless AP (if you have the Wi-Fi function) or the Service Panel (Load center). This DDP is designed to perform at an environment between -10 degrees C to +40 degrees C that should cover the majority of indoor environments.



#### **Attention**

Please call the installer if you have below conditions:

1. You are unable to understand how it works.
2. You notice any operation anomalies.
3. You don't understand or fear that you can't complete the fully install steps.
4. This device must be installed in rooms with suitable environmental conditions (see technical data).

**DO NOT install outdoors.**

5. Don't equip to operate in environments that have particular flammability or explosive conditions.

**For US Users:**

See below PV micro inverter system installation instructions. After installing Data Collector, you can plug into 120Vac wall socket. In order to have good communication between Data Collector and PV micro inverter system, you should install a power line phase coupler(see below picture). It is an in-box passive circuit that couples power line signal for different phase of residential power line communication. After installation, you should set Internet Interface. See page 20 to finish all of installation.

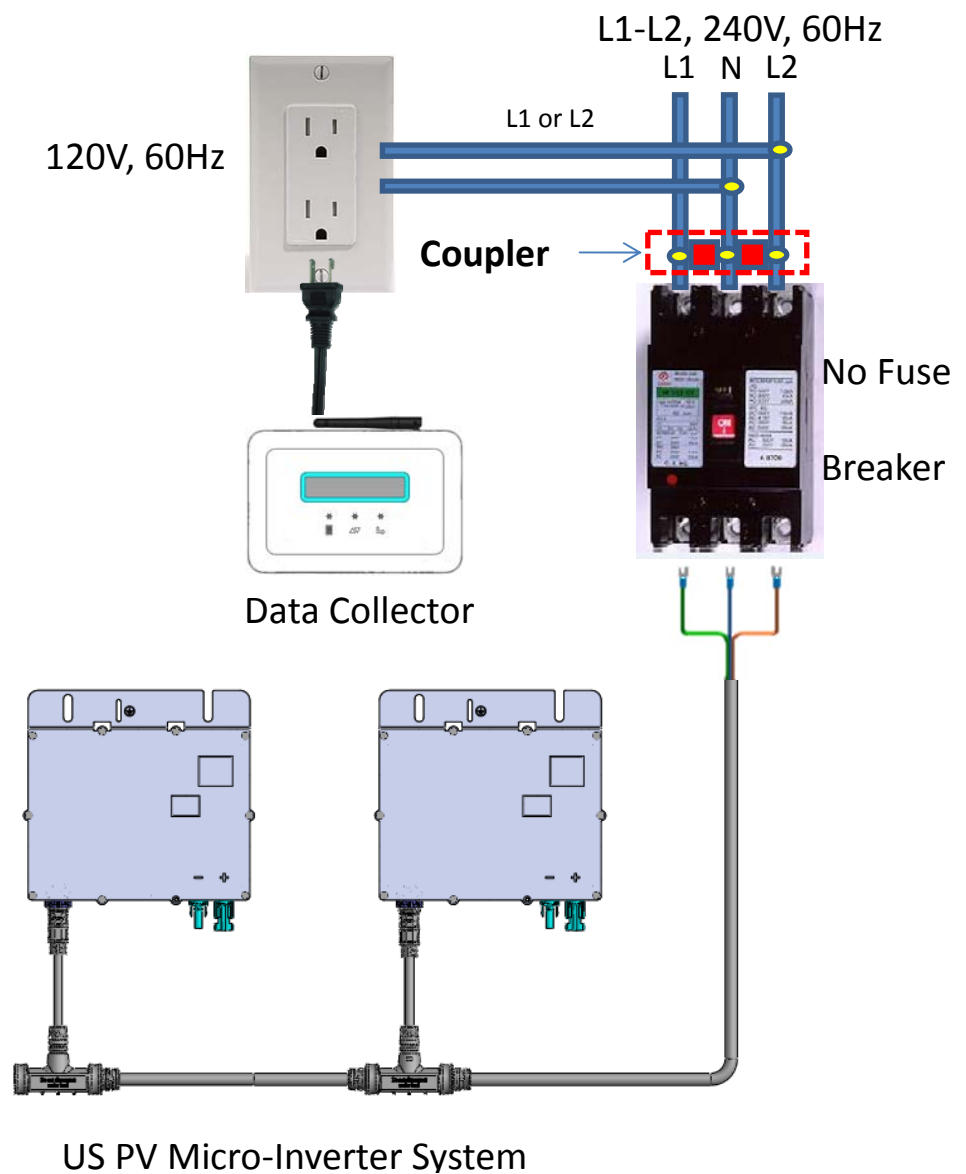

### For European Users:

See below PV micro inverter system installation instructions. After installing Data Collector, you can plug into 230Vac wall socket. And then, you should set Internet Interface. See page 20 to finish all of installation.

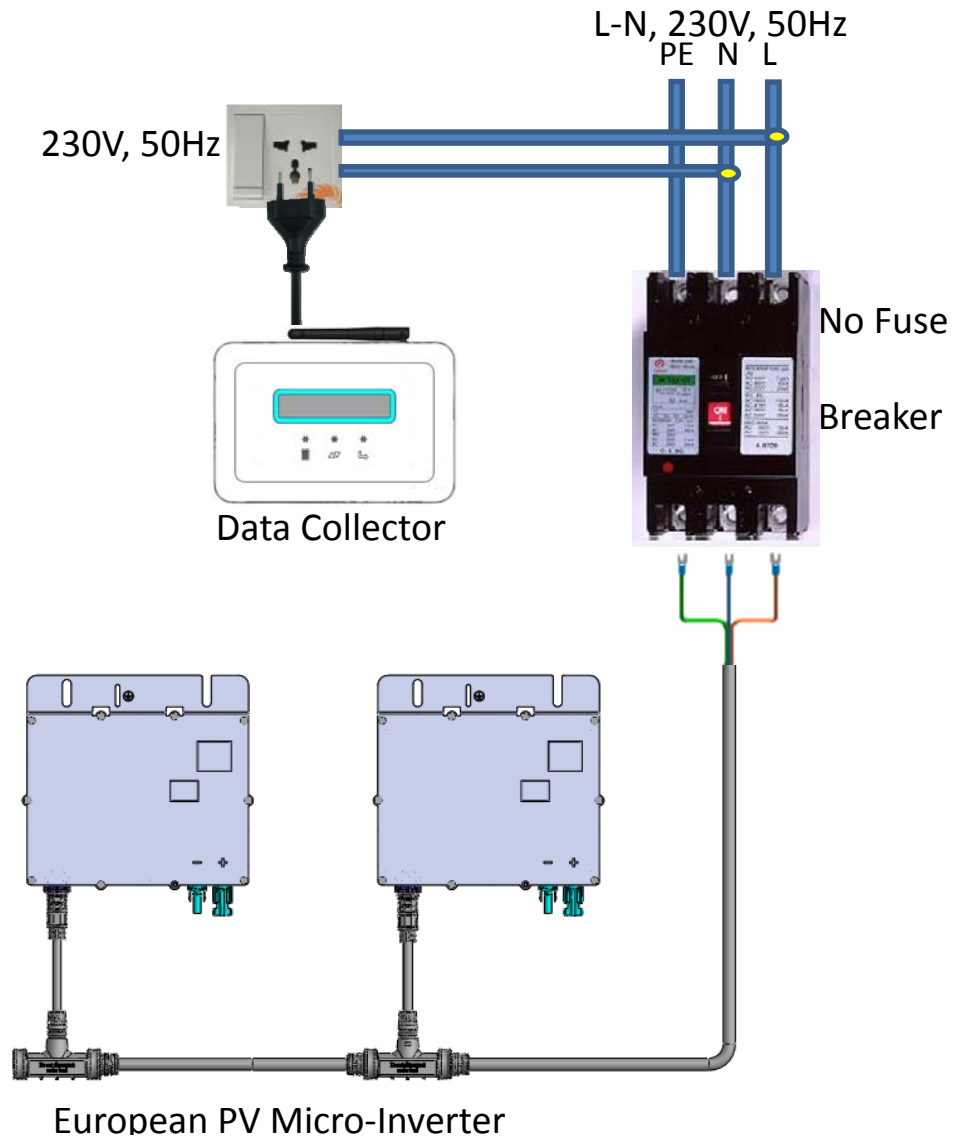

### Wall Mounting

**(Caution: For safety consideration, the device must be mounted on a wall)**

Customer can choose to wall mount this device.

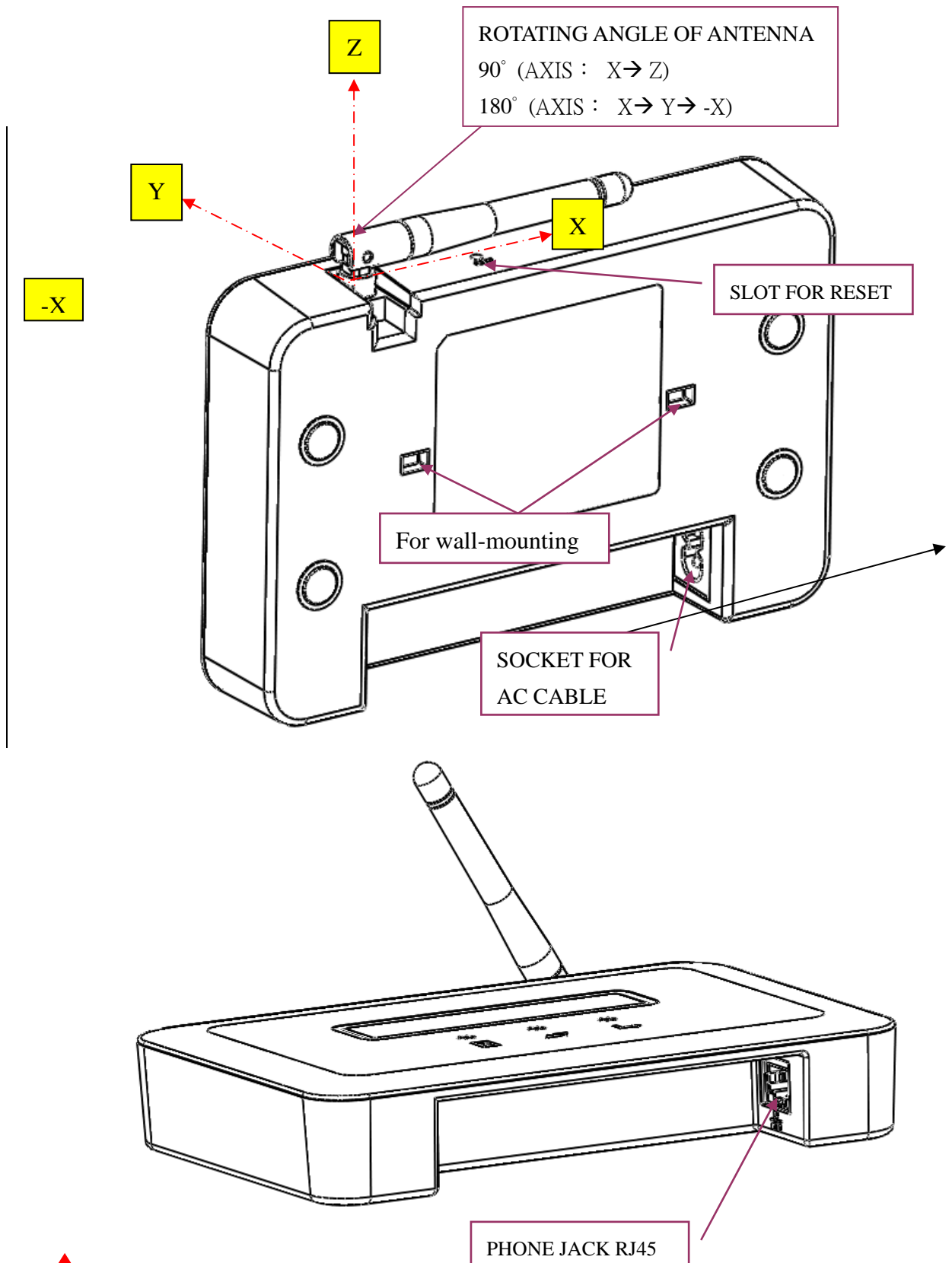

**Attention**

Please follow rotating angles of Antenna same as the above picture. Please install during the daytime to make sure it can connect with inverters.



Refer to the following pictures and steps for wall-mounting.

- 1) To drill two holes at the distance of 83mm on the wall.  
Recommended drill size: 3/16( $\phi$  4.7)
- 2) To insert two conical anchors in the drilled holes.
- 3) To use two screws to mount the wall-bracket on the conical anchors.

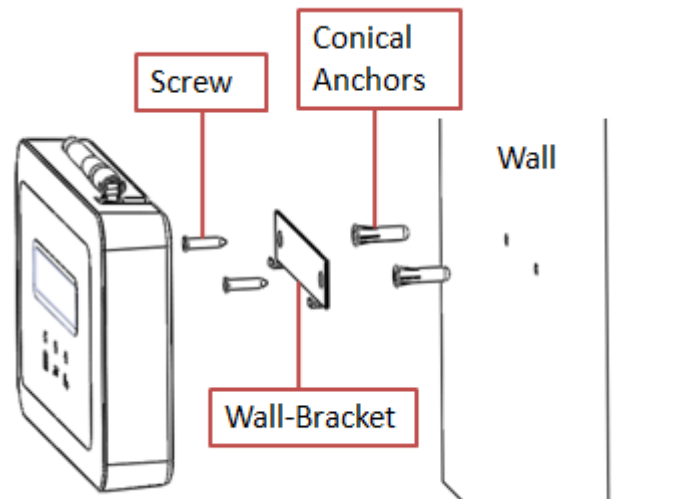

Looking at the picture shown below, the function of three marks is "**MENU**", "**DOWN**" and "**SELECT**". To press down lightly on these marks to operate the DDP menu functions (Refer to page **12**).

The "**MENU**" mark also serves as the "**RETURN**" key for certain features within the menu functions

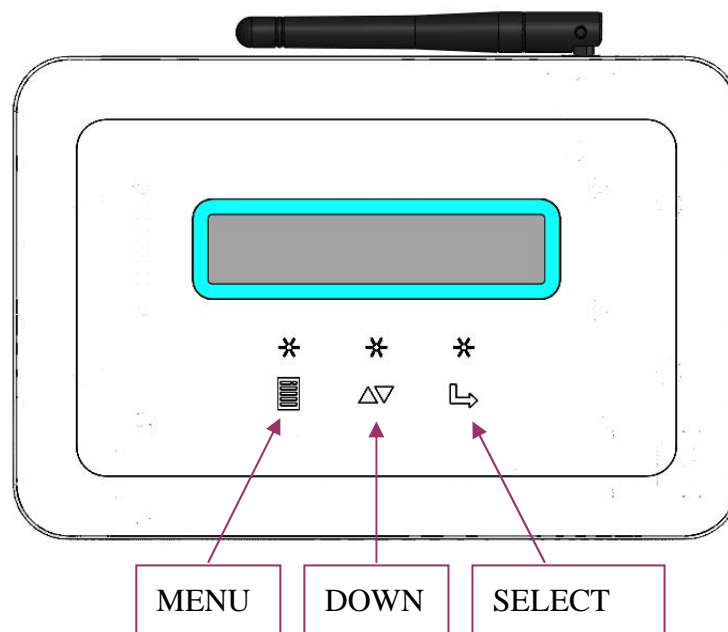

## Reallocating the DDP

If you ever lose power, or need to relocate the DDP to another location, just plug it in (if not already done) and let the DDP restart again. It will resume operation when power and internet connection are restored.



### Attention

Please put DDP on the Recycle Bin because it can be recycling.

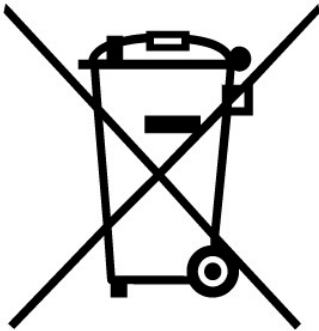

### 3. DDP Operation

#### Starting the DDP

After plugging the power cord, you will see the "Wi-Fi DEVICE" and "ETHERNET DEVICE" message display on the LCD of the DDP. It requires you to choose one device to be the data transmitter. If you do not have an AP router or Wi-Fi function, you only can choose the "ETHERNET DEVICE" option. Otherwise, the device will not operate.



> Wi-Fi DEVICE  
ETHERNET DEVICE

After the initial setup, the system restores the default value or user setting. It will then display the IP address and Power in watts on the LCD after initializing is finished.

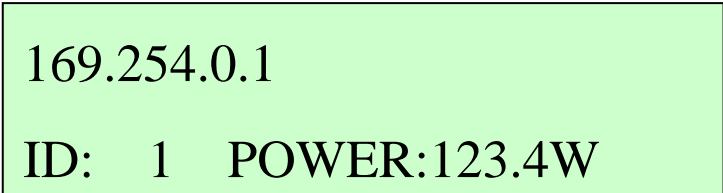

169.254.0.1  
ID: 1 POWER:123.4W

The LCD display will then change to become a calendar with power information after 10 sec.

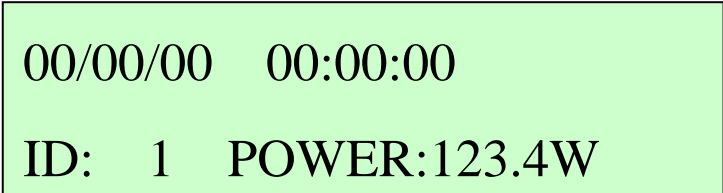

00/00/00 00:00:00  
ID: 1 POWER:123.4W



#### Attention

If you do not choose a valid device, the display will remain on the device choice menu. The OLED fonts will disappear after user selects a device. If you would like to choose another transmitter again, you can select the "SYSTEM RESET" function of the menu or "Reset Button" of the slot to go to the initial step.

Wi-Fi operates at a frequency of 2.4GHz that follows the IEEE802.11b/g communication standard. The 802.11g has a maximum raw data rate of 54Mbps/s and data access rate as defined in 802.11g. Sometimes, the RF signal **decay** or **interference** will be caused the data lose or DDP disconnection. So, please find the places which no interference or decay to let RF signal stable and strong. For WiFi compatible list, please refer the WiFi supplier web site.

The Ethernet speed supports 10/100 Mbps. Please change router setting to support it if you use the 1000Mbps router.

Our device can't support the internet which has "**Proxy**" or "**Firewall**" and "**ISP disconnect**" to transmit the data. So, please kindly checking about these conditions if you meet the data can't transmit to the server.

## DDP MENU

The DDP has three buttons on the box labeled, "MENU", "SELECT" and "DOWN". The user can depress the "MENU" button to turn on the LCD Display (OLD) menu. Our DDP OLD menu includes the "**OLED CONFIG**", "**DATE/TIMING SET UP**", "**DST CONFIG**", "**LCD DISPLAY CONFIG**", "**SYSTEM RESET**", "**RSSI DETECT**", "**WPS (WiFi Protection Set up) START**" and "**EXIT MENU**". You can use the "DOWN" button to scroll the menus that are like interface menus (OLED/TIME) and SYSTEM MENU (RSSI DETECT/SYSTEM RESET/WPS START) and so on.

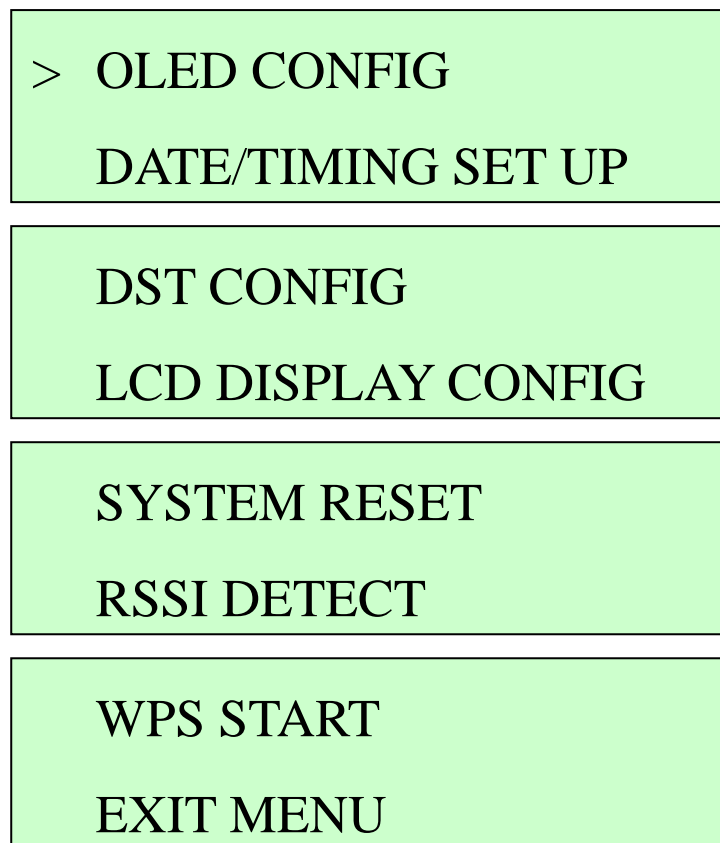

### Attention

"**RSSI DETECT**" and "**WPS START**" menu can choice if user selects the **WiFi** transmitter. If you choice another (Ethernet), it will disappear. All settings are not storage beside the "**DST CONFIG**". Please re-set again if you plug AC on/off.

## Interface Screen (OLED / DATE)

This screen lets the user adjust the function status. User can press "OLED CONFIG" menu to choose the OLED fonts display or dormancy mode. You can manually configure the calendar when you choose the enable item in "DATE/TIMING SET UP" menu.

OLED CONFIG  
DATE/TIMING SET UP

In OLED menu, the user can select "POWER ALWAYS ON" or "POWER SAVE MODE". "POWER ALWAYS ON" means the OLED fonts will always stay lit. "POWER SAVE MODE" means the OLED fonts will darken after 30 sec and LED will blink at right up side. The OLED fonts will light again when the user presses any buttons. The default value is "POWER SAVE MODE".

POWER ALWAYS ON  
# POWER SAVE MODE

In DATE/TIMING menu, you can adjust the calendar manually. The '#' will appear when you press "SELECT" and then you can adjust it. The value adjusts individually as you press the "DOWN" button. The character will blink per second when you hold it. It will jump to next value to adjust when you press the "SELECT" button. The '#' will disappear when set up is finished.

DATE: 00/00/00  
TIME: 00:00:00

You do not need to adjust calendar manually if you register with our Delta Solar EMS webpage. It can get the local time automatically. The default values are 00/00/00 00:00:00.



### Attention

The DATE indicate as: Year / Month / Day

The TIME indicate as: Hour/ Min / Sec

### Other Screen (DST / LCD DISPLAY)

In this screen, you can choice Daylight Saving Time (DST) mode or change the LCD display information.

DST CONFIG  
LCD DISPLAY CONFIG

DST is different with other countries. So, you can select the DST menu to "ENABLE" (+1 hour) or "DISABLE" (-1 hour) it to choice. The default value is "DISABLED".

ENABLE  
#DISABLE

LCD DISPLAY can change the inverter power information to inverter status. The status event message can be referenced on page 32. The default is POWER DISPLAY.

#POWER DISPLAY  
STATUS DISPLAY

STATUS display: (Status must be referred page 32)

169.254.0.1  
ID: 1 STATUS: XXXX

### System Screen (SYSTEM RESET / RSSI DETECT / WPS START)

This screen has two situations.

It includes "RSSI DETECT" and "WPS START" menu if user choices **WiFi** to be transmitter.

SYSTEM RESET  
RSSI DETECT

WPS START  
EXIT MENU

The other has no above menus if user choices **Ethernet** to be transmitter.

**SYSTEM RESET**  
**EXIT MENU**

If you choose the wrong one or want to change the transmit device, you can go into the "SYSTEM RESET" item and then display confirm message "RESET DEVICE?" It will return to select the transmit device menu again by pressing "SELECT". Note, it will also clear all the setting after pressing. You can return to original menu if you press "MENU". It does not affect the PLC data of the memory but system data of DDP will return to default. So, it will display power information if you register EMS again.

**RESET DEVICE?**  
**MENU:NO    SELECT:YES**

The WiFi signal strength detect between DDP with AP router if user press "RSSI DETECT". It will display "SCANNING..." if you have already connected with AP and press it.

**SCANNING...**

Otherwise, it will display "SCAN CAN'T WORK PLEASE CONNECT AP" message if user don't connect with AP first.

**SCAN CAN'T WORK**  
**PLEASE CONNECT AP**

It will take few seconds (less than 1 min) to detect DDP with AP router signal strength. Then, it will display "SCANNING FINISH PRESS 'MENU' BACK" message to indicate the scan function has finished.

**SCANNING FINISH**  
**PRESS 'MENU' BACK**

You can press "MENU" button back to menus or back to power information after 30 second timeout.

You will see the WiFi signal strength display on LCD as bellow:

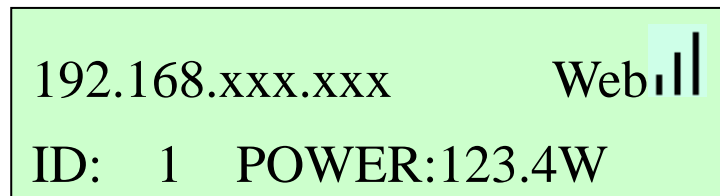

If your AP router has logo  and use the WiFi to be transmitter, it also can use the WPS function to do quick communicate with AP router. It just only can support the security **above WPA** mode, such as WPA, WPA2...etc. (It can't support WEP serials.)

It will display the "**WPS EXECUTION PLEASE WAIT...**" if user presses the "**WPS START**".

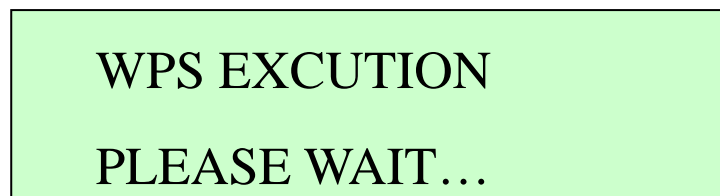

Please press the **WPS** button on the AP router (you can refer AP router manual to find it), then AP router indicator will blinking and start to find the device which want to connect each other.

It will cost about **30 seconds** to connect and get new IP if it connects successful. The success message will display as below:

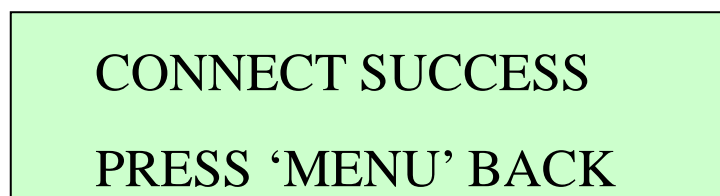

It will reconnect 3 times if AP router blinking doesn't dark and find any devices. So, it will cost almost 1'30 seconds. The "**CONNECT FAIL**" message display as below if it also can't find any devices. Press "**MENU**" and then press "**ENTER**", you also can do WPS again.

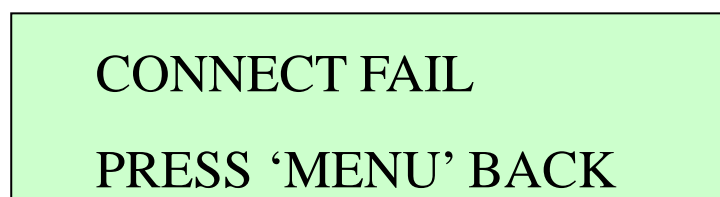

It will display as below message as you press "**WPS START**" function again if you have already connected successful.



**IT HAS CONNECTED  
WPS CAN NOT WORK**

**NOTE:**

We suggestion you don't use WPS function if your AP router doesn't have



If you want to do it when you have already connected, you must press **“SYSTEM RESET”** to do again.

Finally, it will return to power information when you press the **“EXIT MENU”**.

**Restart the DDP**

If the utility power fails, or you need to restart the DDP equipment, just press the Reset button to start up again. It will resume operation when power and internet connection are restored. If you use the Wi-Fi transmittal method, you need to reset again to connect the internet. When it resumes operation, the LCD window displays the **“Wi-Fi DEVICE”** and **“ETHERNET DEVICE”** message. The LCD window will display the following:

**> Wi-Fi DEVICE  
ETHERNET DEVICE**

After the restart step, normal operation resumes.

**Normal Operation**

Begins or resumes normal operation when the DDP system initialization is complete. At this point, the LCD will display as below:

**192.168.xxx.xxx                  Web  
ID: 1    POWER:123.4W**

On screen display values are indicated as bellow:

- The IP address, such as: **192.168.x.x** (your actual local IP will be different from your AP configuration)

- The **Web** appears if the DDP gets DHCP from user AP router. Otherwise, it will disappear.
- Indication of the present panel ID, in **ID: xxx** (where xxx is a value which get from the PV micro inverter serial number )
- Indication of the present power-production, in **power: xxx W** (where xxx is a value from the actual panel value)

## 4. Troubleshooting

If you experience problems, some of them are described below. For system status and event message information, please see Event Messages on page 32.

### Potential Problems and Solutions

#### IP Address Problem:

If the IP address displayed on the DDP LCD does not match or you get the DHCP subnet from your internal network or AP router, it always shows "**169.254.0.1**", it means it was unsuccessful to obtain a DHCP from your AP router. Check network connectivity to the AP router or other DHCP server. You may also wish to contact your Internet Service Provider or refer to your AP router documentation for assistance or setting.



#### **Attention**

WiFi signal strength will depend on user's AP router distance. So, please possibly to set up our device near with your AP router to make sure RF signal have low decay or interference. You must change your AP router channel to others if you meet our device not easily to connection each other. If interference serious, it easily to meets this symptom.

## 5. DDP Internet Interface

You need the Internet to connect with our Delta Solar EMS webpage to monitor and analyze the information recorded.

If you use **Wi-Fi** to be your transmitter type, please follow the method below to connect to our Delta Solar EMS webpage step by step. If you press the “**WPS START**” to get the new IP address successful, you can skip to **step 4** operate.

Skip to **step 5** and press the **I Accept** button if you use the ETHERNET.

### Login and Register Screen with Connect to Internet

Step 1. Please select the **DELTA\_XXXXXXXXXX** and connect to it after the system startup. X is Wi-Fi MAC address.

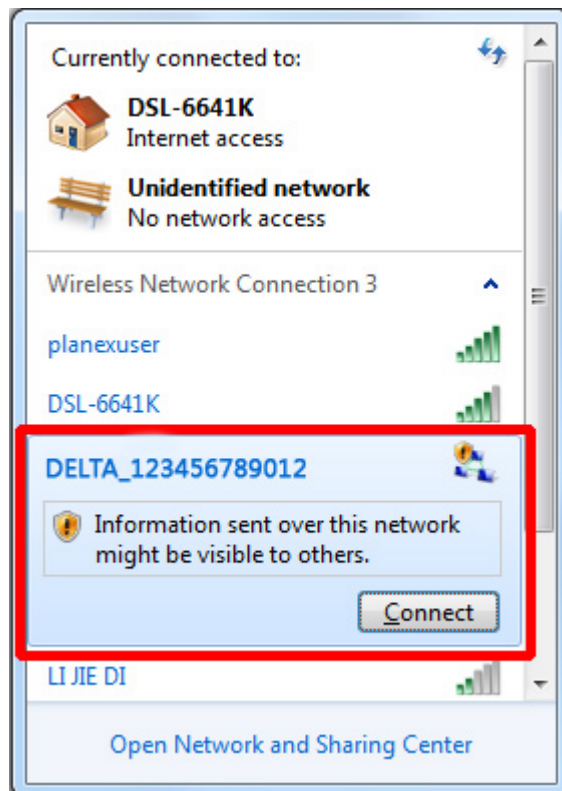

Step 2. Press **169.254.0.1** on your notebook (or computer) with Wi-Fi function to connect device. Then press **Scan Wireless Networks** button. You should see all AP router lists after device detecting has finished.



Step 3. Please select your AP router to be your data transmitter. There is no need to do anything further if your AP router is not set to encryption mode. Otherwise, input the password if your AP router is set to encryption protect mode.

#### SCAN Wireless Networks:

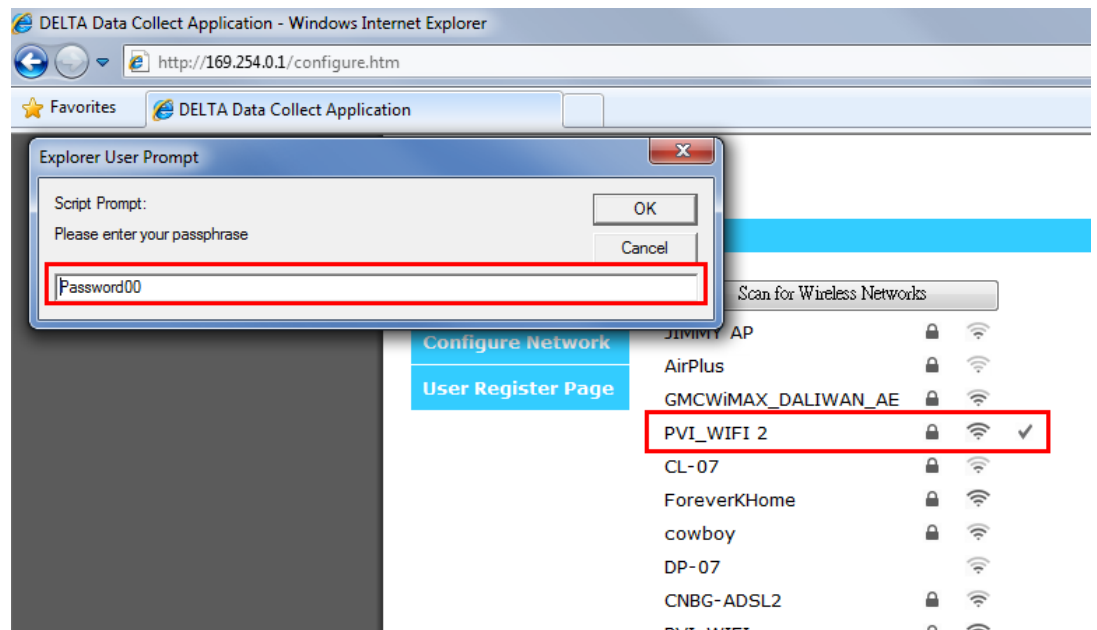

#### Other Network Manually:

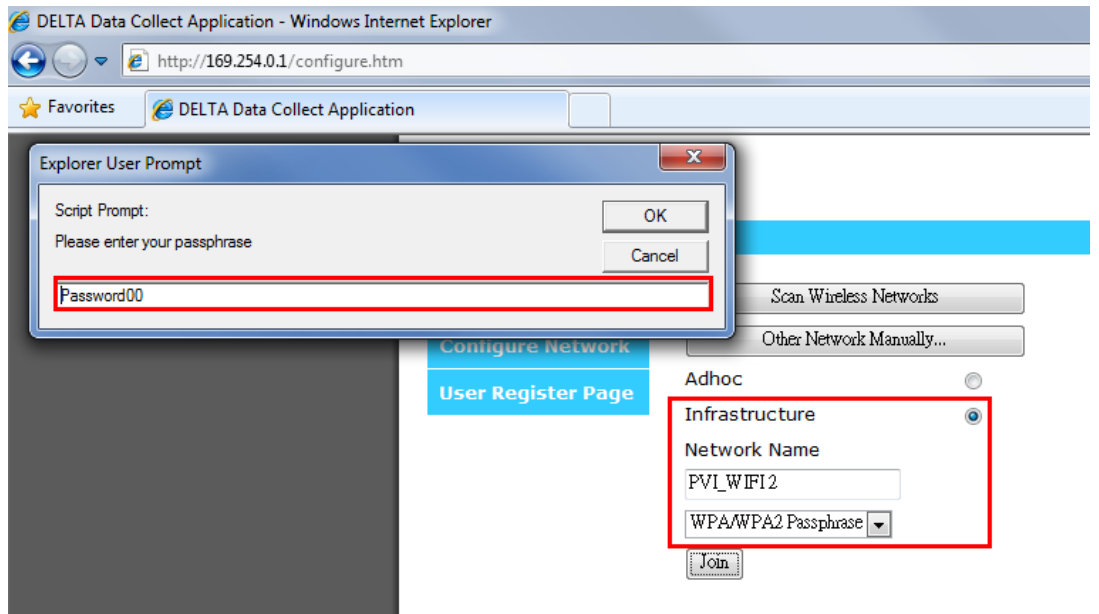

- User Host Setting
- Configure Network
- User Register Page

## Reconnection in Progress

A connection to another network is now underway! You will need to connect this laptop/PC/portable device to the new network ("PVI\_WIFI 2") to regain access.

As a reminder, this is the network you were on:

- **SSID:** "DELTA\_001EC001EBCA"
- **WLAN type:** adhoc (IBSS)

This is the network that you will be going to:

- **SSID:** "PVI\_WIFI 2"
- **WLAN type:** infrastructure (BSS)

Step 4. Your PC must change the AP router which you selected. Then your PC can communicate with the DDP again.

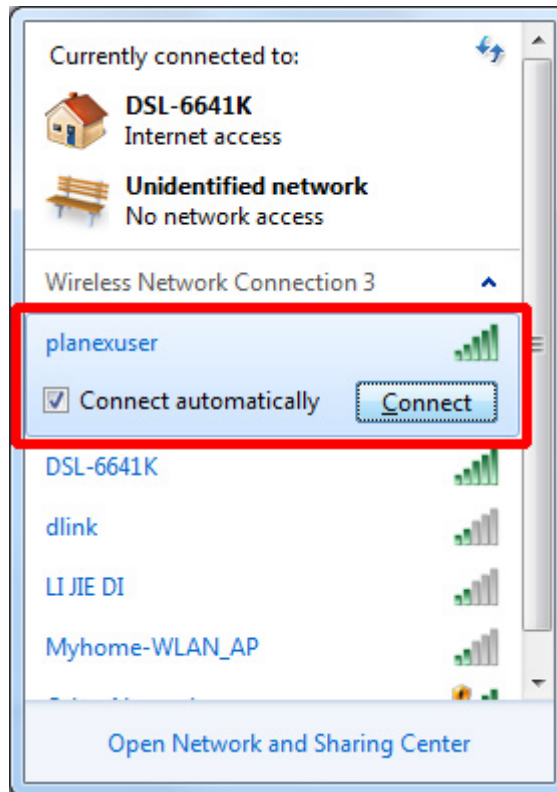

Step 5. After selecting finish, user needs to choice “**User Register Page**” firstly and then, pressing the **I Accept** button to connect with our website.



Step 6. Once the Delta Solar EMS appears, the user needs to register one new account for our database. You must register one account for our webpage to monitor the information if you have never registered.

LOG IN FORM (OR SIGN UP) ✕

Account

.....

Remember me ENTER

[Forgot password or account?](#)

Step 7. Register your detail personal data if you are new user.

## SIGN UP

Account:	<input type="text"/>	(Check)
Password:	<input type="password"/>	
Confirm Password:	<input type="password"/>	
Email:	<input type="text"/>	
First Name:	<input type="text"/>	
Last Name:	<input type="text"/>	
Security Question:	13 - 16 = ?	
	<input type="text"/>	

**SUBMIT**  Agree the Terms of Use

Step 8. Login Delta Solar EMS.



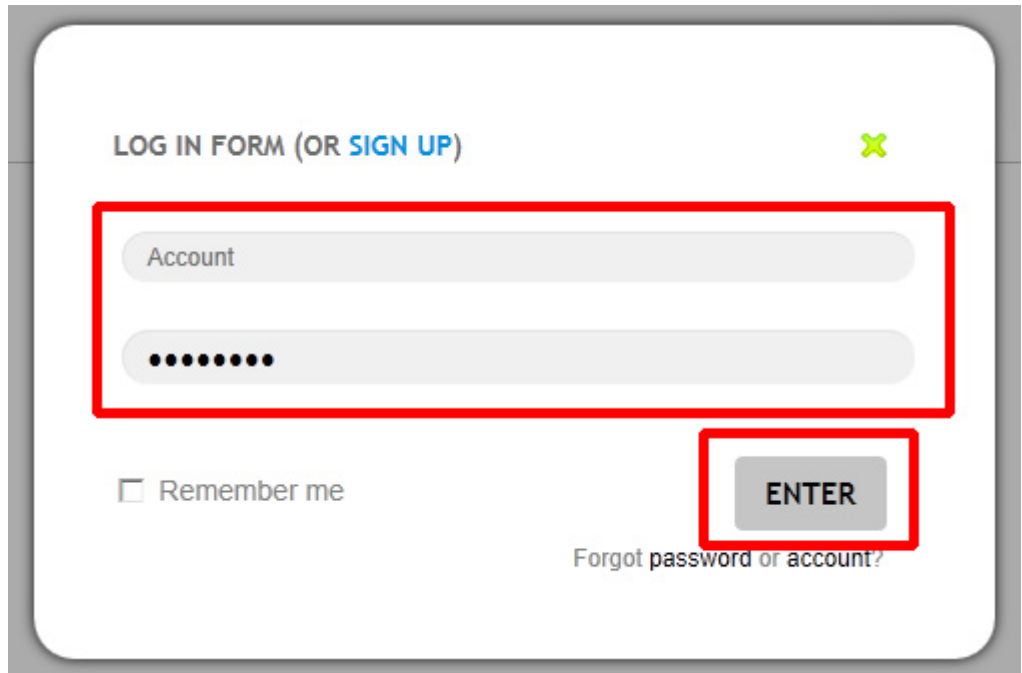

Step 9. If you are newer, it will show the PV micro inverter Serial Number register information. You just register serial numbers which you have. Or else skip to step 12 to reactive device or update setting.  
Register

### PLEASE ENTER THE INVERTER SERIAL NUMBERS

Inverter Serial Number 1:

Inverter Serial Number 2:

Inverter Serial Number 3:

Step 10. Register the collect name, time zone and location

## COLLECTOR REGISTRATION

Collector Serial Number:	<input type="text" value="C1116000031"/>
Collector Name:	<input type="text" value="Vince Test"/>
Timezone:	<input type="text" value="(UTC+09:00) Tokyo"/> ▼
Address:	<input type="text" value="Tokyo"/> <a href="#">Update Map</a> <a href="#">Detect My Current Address</a>



Auto update address when you drag to set marker position.

NEXT

Step 11. Check the DDP and other information

## COLLECTOR REGISTER

**Collector Name:** Test Hoc 1  
**Location:** Taoyuan City, Taoyuan County, Taiwan 330  
**Collector manufacture:** Delta  
**Collector model:** EBDD\_DDC  
**Collector number of Inverter:** 3  
**Timezone:** GMT+8:00

BACK

SUBMIT

Step 12. You will see this page if you ever registered your device. There are two statuses will display as bellow: one is reactive directly if you ever register. Another is updating the inverter serial number and collector location information if you want to add new inverters or change your DDP location.

# COLLECTOR REGISTER

REACTIVE

EDIT SETTING

Step 13. After pressing the "SUBMIT" or "REACTIVE", you can see the message "PLEASE AWAIT CONFIG" display on LCD. The time count is depending on your PV micro inverter numbers to connect with DDP.

The power information displays after time counting finishes.

PLEASE AWAIT CONFIG

XX:XX



## Attention

The DDP connects with PV micro inverters by using the power line communication (PLC) method. It takes some times to connect, but it doesn't connect successful because the PLC can't verify success. So, it will display two statuses as bellow if time count has finished.

Status 1 : It connects successful if LCD displays the power information after few minutes.

192.168.xxx.xxx                      Web

ID: 1    POWER:123.4W

Status 2: It connects fail if LCD doesn't display power information. For this status, it needs to spend some time to connect again until it connects successful. Please kindly inform our service if it always can't display after 20 min or above.

192.168.xxx.xxx                      Web

ID: 1    POWER:              W

Step 14. After checking, you can scroll the lists to see the detail information of all inverters from the website as shown below.

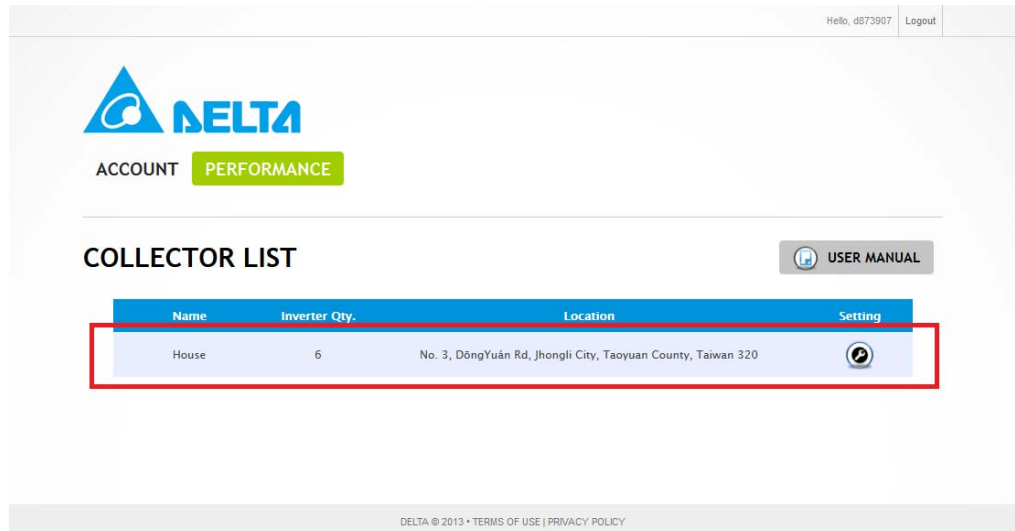

Step 15. You also can see the power data of the individual panel display by different date types.



### Attention

The best resolution is 1024x768.

The browsers are below:

Google Chrome

Firefox 4.0+

Internet Explorer 8.0+

Safari 5.0+

Opera 11+

## Monitor with no Internet

Step 1. Please select the **DELTA\_XXXXXXXXXX** and connect to it after the system startup. X is Wi-Fi MAC address.

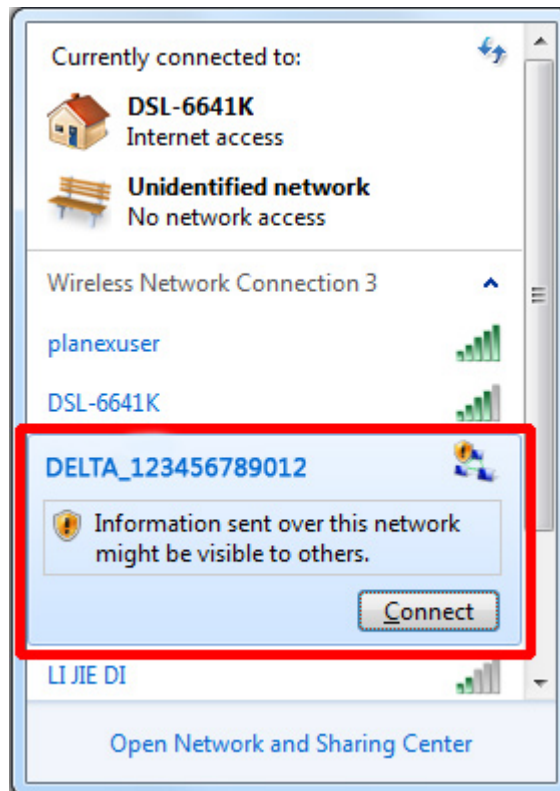

Step 2. Press **169.254.0.1** on your notebook (or computer) with Wi-Fi or ETHERNET function to connect device. Then choice the "User Register Page".



Step 3. Keying your inverter serial number in this page. You can press "+" to increase and "-" to decrease the inverter number. Press "Setting" if you set it finish. And please repeat step 3 and step 4 again if you set fail.

- User Host Setting
- Configure Network
- User Register Page

## DELTA Data Collect Device Setup

### Local Setting

Setting Inverter Serial Number:

Inverter Serial Number 01:  +

Setting

Copyright © 2011 DELTA Technology, Inc.

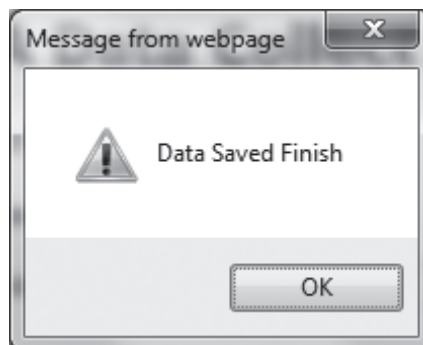

Step 4. After pressing the "SETTING", you can see the message "PLEASE AWAIT CONFIG" display on LCD. The time count is depending on your PV micro inverter numbers to connect with DDP. The power information displays after time counting finishes.

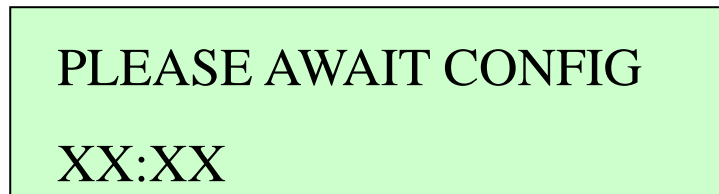

#### Attention

The DDP connects with PV micro inverters by using the power line communication (PLC) method. It takes some times to connect, but it doesn't connect successful because the PLC can't verify success. So, it will display two statuses as bellow if time count has finished.

Status 1 : It connects successful if LCD displays the power information after few minutes.

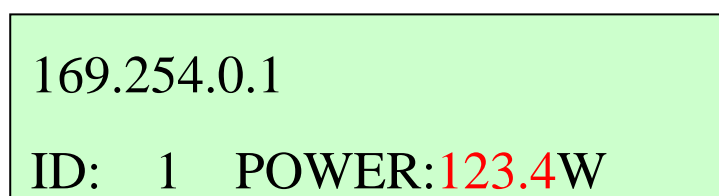

Status 2: It connects fail if LCD doesn't display power information. For this status, it needs to spend some time to connect again until it connects successful. Please kindly inform our service if it always can't display after half hour or above.

169.254.0.1  
ID: 1 POWER: W

### User Host with Connect to Internet

Step 1. Please refer the "Login and Register Screen with Connect to Internet" session to follow from step 1 to step 4 if user select the WiFi transmitter or reference

Step 2. It can modify the IP address or domain name by user if you follow the step1. Otherwise, it will block if you don't connect to internet.



Press the "Setting" if you key in finish. The default is our host.



Step 3. Then, please keep following the step 5 until finish all operations with **“Login and Register Screen with Connect to Internet”** session.

## Event Messages

The table below lists the all messages that the DDP can produce to indicate certain conditions. These messages are displayed on our webpage and they can provide Delta Customer Support with needed information, if you should call for assistance.

The Message Displayed:		
LCD Status Indication	EMS Status	Description
0001	Input over voltage	The PV Micro-Inverter detects an input over-voltage event
0002	Input under voltage	The PV Micro-Inverter detects an input under-voltage event
0004	Input over current	The PV Micro-Inverter detects an input over-current event
0008	Output over voltage	The PV Micro-Inverter detects an output over-voltage event
0010	Output under voltage	The PV Micro-Inverter detects an output under-voltage event
0020	Output over current	The PV Micro-Inverter detects an output over-current event
0040	Output over frequency	The PV Micro-Inverter detects an output over-frequency event
0080	Output under frequency	The PV Micro-Inverter detects an output under-frequency event
0100	Islanding effect	The PV Micro-Inverter detects an unintentional islanding event
0200	Ground fault detection & interruption	The PV Micro-Inverter detects a ground fault event
0400	Main point over temperature	The PV Micro-Inverter detects an over-temperature event from main thermal sensing point
0800	Second point over temperature	The PV Micro-Inverter detects an over-temperature event



		from second thermal sensing point
4000	Loss feedback message	This data collector can't communicate with PV micro-inverter

P.S: For example, if "**Input over voltage**" and "**Output over current**" happen on the same time, the LCD status indication will display "**0011**".



### **Attention**

Please don't dismantle the device or make any repairs if you are not installer or qualified personnel. These error messages must perform by these personals. So, please call these personals if you can't solve error problems.

## 6. Technical Data

<b>Communication Interface</b>	
Power Line	Narrowband PLC Up to 28.8kbps
Ethernet	10/100BASE-T / IEEE 802.3™
Wi-Fi	IEEE Std. 802.11b/g™ 2.4 GHz / 11/54 Mbps
DHCP Client Service	Yes
<b>AC Input Power Requirements</b>	
Minimum Input	90(Vrms)
Maximum Input	264 (Vrms)
Nominal Input	100-240(Vrms)
Minimum Input Frequency	47(Hz)
Maximum Input Frequency	62(Hz)
Nominal Input Frequency	50-60(Hz)
Input power (maximum)	6W
<b>Mechanical Data</b>	
Outside Dimension (W x H x D)	172.4mm x 114.9mm x 31.2mm
Weight	700g +/-10g
Maximum operation altitudes	Sea level 3000 m
Operating Temperature	-10° C to +40° C
Cooling	Natural convection – no fans
Enclosure Environment Rating	Indoor - NEMA 1
<b>Display</b>	
Two Columns OLED Display	Yes
<b>Safety and Standard</b>	
Compliance (Wi-Fi Module)	IEC 60950-1, FCC Part 15 Class B FCC Part 15, Subpart C
<b>Reliability and Warranty</b>	
Warranty Period	1 year
Maximum PV micro Inverter	72pcs*

\*Please kindly refer to Delta assembly manual of micro inverter to ensure you install correctly.



### **Attention**

**Delta reserves the right for specification change**



### **Attention**

For one data collector just can only set up these pieces at the single phase. If you need to cross over the other phases, the PLC signal strength will have decay or interference problems. It may be caused data loses symptoms.