



Zigbee Module

Data sheet

DFZM-TS2xx

An IEEE 802.15.4 System-On-Chip Zigbee module



Contents

1.	Features	4
2.	Zigbee Model No. Definition.....	6
3.	Architecture.....	7
	3-1.Block Diagram.....	7
	3-2.Block Diagram Description	8
	3-2-1.Overview	8
	3-2-2.CPU and Memory.....	8
	3-2-3.Clocks and Power Management	9
	3-2-4.Peripherals	9
	3-3.Power Management	13
4.	Pin-out and Signal Description	15
	4-1.Device Pin-out Diagram (Module top view)	15
	4-2.Module Pins Description	16
5.	Electrical Characteristics	18
	5-1.Absolute Maximum Rating.....	18
	5-2.Recommended Operating Conditions.....	18
	5-3.Power Consumption.....	18
	5-4.DC Characteristics	20
	5-5.Wake-up and Timing.....	20
	5-6.Radio Parameters	21
	5-7.ADC Parameters	22
	5-8.SPI AC Characteristics	24
6.	Package and Layout Guidelines.....	26
	6-1.Recommended PCB Footprint and Dimensions.....	26
	6-2.Layout Guidelines.....	30
	6-2-1.Surface Mount Assembly	32
	6-3.Recommended Stencil Aperture	34
7.	Ordering Information	36



Revision History

Version	Date	Reason of change	Maker
0.1	2013/3/11	Initial release	Fred
0.2	2013/4/26	Add Peripheral I/O Pin Mapping	Fred
0.3	2013/7/1	Add "Not available for DFZM-TS21X-DT0R" at 4-2. Module Pins Description(Pins 10 、 13 、 25)	JunRu
0.4	2013/8/22	Update power consumption and radio parameters	JunRu

DFZM-TS2xx IEEE802.15.4 System-On-Chip Zigbee Module

THIS DOCUMENT describes the DFZM-TS2xx Zigbee module hardware specification. The CC2530 based modules provide cost effective, low power, and flexible platform to add Zigbee connectivity for embedded devices for a variety of applications, such as wireless sensors and energy monitoring. It combines 8051-based processors, in-system programmable flash memory, 8-KB RAM, 256KB flash memory and off module certified antenna options, and various RF front end options for end customer range needs in order to provide a Zigbee and regulatory certified. The module has various operating modes, making it highly suit for system where ultralow power consumption is required. Short transition times between operating modes further ensure low energy consumption.

1. Features

- ▶ Family of modules with different antenna and output power options:
 - DFZM-TS22x 22 mm by 16 mm by 3.3mm (Length * Width * Height) 28-pin Dual Flat pack PCB Surface Mount Package.
 - DFZM-TS21x 27 mm by 16 mm by 3.3 mm (Length * Width * Height) 28-pin Dual Flat pack PCB Surface Mount Package.
 - DFZM-TS220, DFZM-TS221, DFZM-TS210, and DFZM-TS211 are all pin to pin compatible (see section 7 Ordering Information), and the user has to account only for power consumption, module outline, and PCB antenna keep out (if used) to accommodate “one size fits all” for various end applications.
 - Simple API for embedded markets covering large areas of applications.
- ▶ Compliant with IEEE 802.15.4 and regulatory domains:
 - RoHS compliant.

- FCC/NCC Certified.

	DFZM-TS220	DFZM-TS221	DFZM-TS210	DFZM-TS211
FCC ID	H79DFZM-TS220	H79DFZM-TS220	TBD	TBD
NCC ID	CCAJ12LP2570T7	CCAJ12LP2571T9	TBD	TBD

▶ Microcontroller:

- High-Performance and Low Power 8051 Microcontroller core with code prefetch .
- 256KB In-System-Programmable Flash.
- 8KB RAM with Retention in all power mode.
- Hardware debug support.

▶ Interfaces:

- Chip antenna or external antenna options.
- Two powerful USART with support for several serial protocols.
- Up to 21 configurable general purpose I/Os.
- Single 3.3V supply option:
 - Wide supply voltage range 2.0 ~ 3.3V.
- One PWM output.
- One 7~ 12-bit ADC with 30KHz~40KHz bandwidth resolution.

▶ Embedded RTC (Real Time Clock) can run directly from battery.

▶ Low-power mode operations.

- ▶ Power mode 1, 2, 3.

2. Zigbee Model No. Definition

D F Z M - T S 2 2 0 - DT 0 R

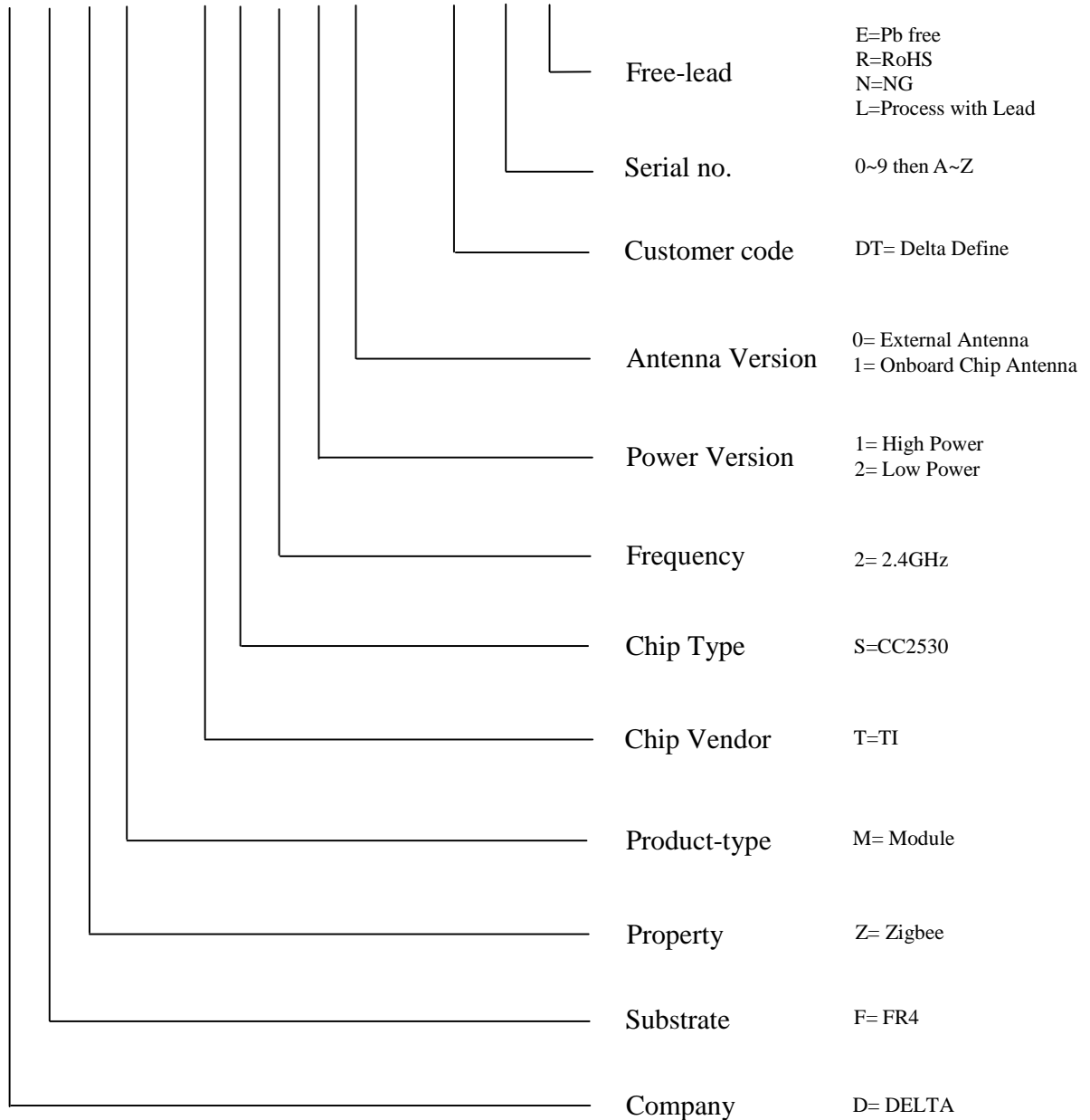

3. Architecture

3-1. Block Diagram

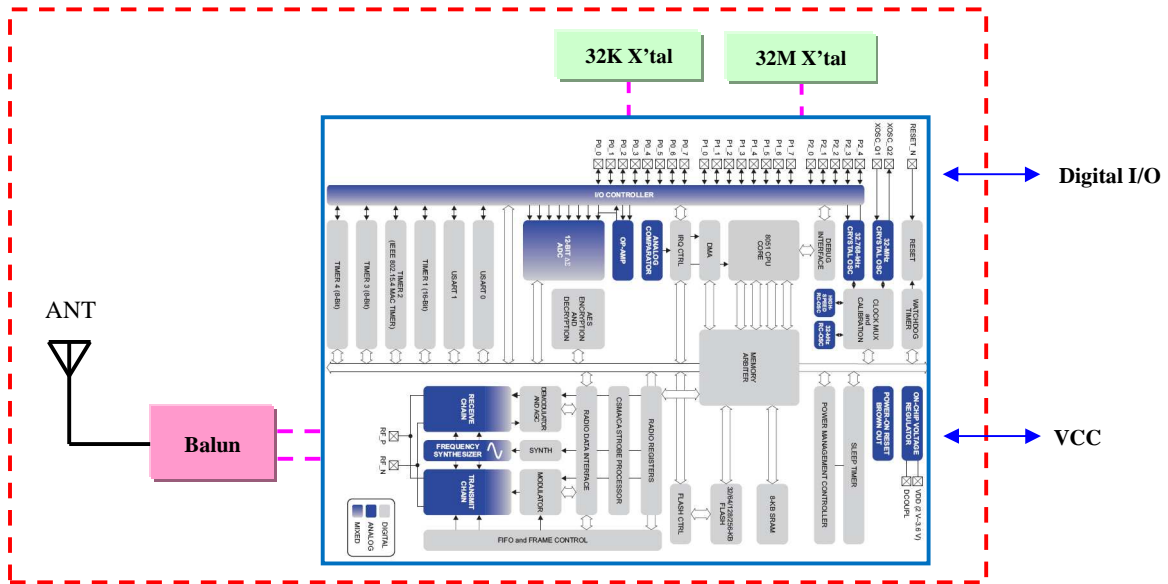

Figure 3-1: DFZM-TS22x Block Diagram

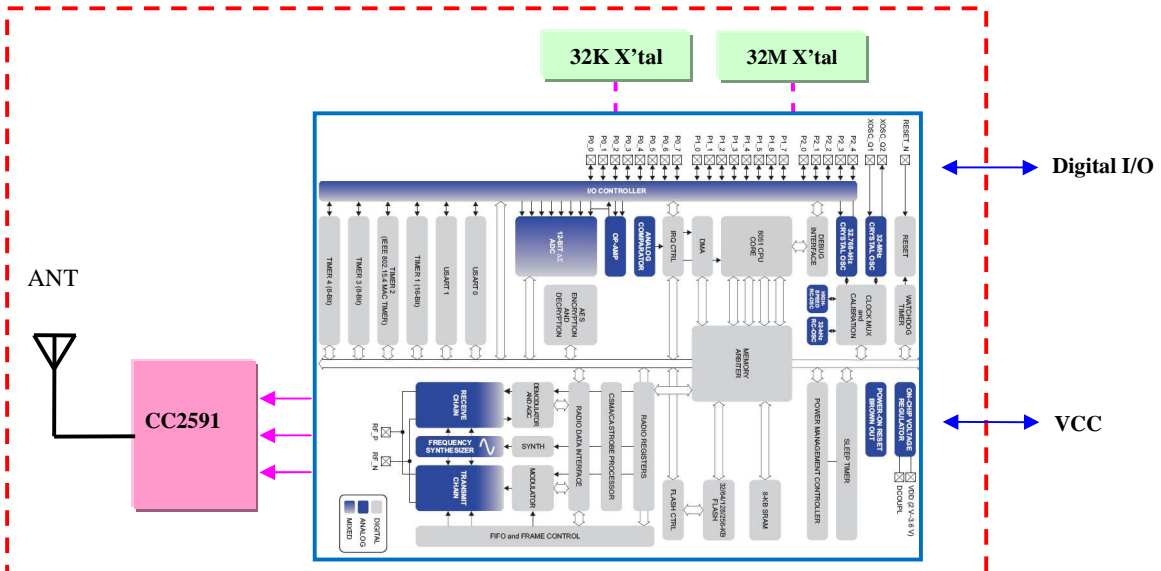

Figure 3-2: DFZM-TS21x Block Diagram

3-2. Block Diagram Description

3-2-1. Overview

DFZM-TS2xx module is a highly integrated Zigbee system-on-chip (SOC) that contains the following:

- The module includes TI CC2530 SoC, which contains CPU- and memory-related, peripherals-related, clocks and power management-related in a single package.
- The module features an IEEE802.15.4-compliant radio transceiver with onboard 32 KHz & 32 MHz crystal circuitries, RF, and certified chip antenna or external antenna options.
 - The low power module option has a capability of +4.5dBm output power at the antenna (see Figure 3-1).
 - The high power module option has a capability of +18.5dBm output power at the antenna (see Figure 3-2).
- Variety of interfaces are available such as two USART and SPI, four TIMER, one 7~12 bit ADC, Operational amplifier and GPIO.
- DFZM-TS2xx contains single power supply (VCC).

3-2-2. CPU and Memory

The **8051 CPU** core used in the CC253x device family is a single-cycle 8051-compatible core. It has three different memory-access buses (SFR, DATA and CODE/XDATA) with single-cycle access to SFR, DATA, and the main SRAM. It also includes a debug interface and an 18-input extended interrupt unit.

The **interrupt controller** services a total of 18 interrupt sources, divided into six interrupt groups, each of which is associated with one of four interrupt priorities. Any interrupt service request is serviced also when the device is in idle mode by going back to active mode. Some interrupts can also wake up the device from sleep mode (power modes 1–3).

The **memory arbiter** is at the heart of the system, as it connects the CPU and DMA controller with the physical memories and all peripherals through the SFR bus. The memory arbiter has four memory access points, access of which can map to one of three physical memories: an 8-KB SRAM, flash memory, and XREG/SFR registers. It is responsible for performing arbitration and sequencing between simultaneous memory accesses to the same

physical memory.

The **8-KB SRAM** maps to the DATA memory space and to parts of the XDATA memory spaces. The 8-KB SRAM is an ultralow-power SRAM that retains its contents even when the digital part is powered off (power modes 2 and 3). This is an important feature for low-power applications.

The **256 KB flash block** provides in-circuit programmable non-volatile program memory for the device, and maps into the CODE and XDATA memory spaces. In addition to holding program code and constants, the non-volatile memory allows the application to save data that must be preserved such that it is available after restarting the device. Using this feature one can, e.g., use saved network-specific data to avoid the need for a full start-up and network find-and-join process.

3-2-3.Clocks and Power Management

The digital core and peripherals are powered by a 1.8-V low-dropout **voltage regulator**. It provides **power management** functionality that enables low power operation for long battery life using different power modes. Five different **reset** sources exist to reset the device.

3-2-4.Peripherals

The CC2530 includes many different peripherals that allow the application designer to develop advanced applications.

The **debug interface** implements a proprietary two-wire serial interface that is used for in-circuit debugging. Through this debug interface, it is possible to perform an erasure of the entire flash memory, control which oscillators are enabled, stop and start execution of the user program, execute supplied instructions on the 8051 core, set code breakpoints, and single-step through instructions in the code. Using these techniques, it is possible to perform in-circuit debugging and external flash programming elegantly.

The device contains flash memory for storage of program code. The flash memory is programmable from the user software and through the debug interface. The **flash controller** handles writing and erasing the embedded flash memory. The flash controller allows page-wise erasure and 4-bytewise programming.

The **I/O controller** is responsible for all general-purpose I/O pins. The CPU can configure whether peripheral modules control certain pins or whether they are under software control, and if so, whether each pin is configured

as an input or output and if a pullup or pulldown resistor in the pad is connected. CPU interrupts can be enabled on each pin individually. Each peripheral that connects to the I/O pins can choose between two different I/O pin locations to ensure flexibility in various applications.

A versatile five-channel **DMA controller** is available in the system, accesses memory using the XDATA memory space, and thus has access to all physical memories. Each channel (trigger, priority, transfer mode, addressing mode, source and destination pointers, and transfer count) is configured with DMA descriptors anywhere in memory. Many of the hardware peripherals (AES core, flash controller, USARTs, timers, ADC interface) achieve highly efficient operation by using the DMA controller for data transfers between SFR or XREG addresses and flash/SRAM.

Timer 1 is a 16-bit timer with timer/counter/PWM functionality. It has a programmable prescaler, a 16-bit period value, and five individually programmable counter/capture channels, each with a 16-bit compare value. Each of the counter/capture channels can be used as a PWM output or to capture the timing of edges on input signals. It can also be configured in **IR Generation Mode** where it counts Timer 3 periods and the output is ANDed with the output of Timer 3 to generate modulated consumer IR signals with minimal CPU interaction.

Timer 2 (the MAC Timer) is specially designed for supporting an IEEE 802.15.4 MAC or other time-slotted protocol in software. The timer has a configurable timer period and a 24-bit overflow counter that can be used to keep track of the number of periods that have transpired. A 40-bit capture register is also used to record the exact time at which a start-of-frame delimiter is received/transmitted or the exact time at which transmission ends, as well as two 16-bit output compare registers and two 24-bit overflow compare registers that can send various command strobes (start RX, start TX, etc.) at specific times to the radio modules.

Timer 3 and Timer 4 are 8-bit timers with timer/counter/PWM functionality. They have a programmable prescaler, an 8-bit period value, and one programmable counter channel with an 8-bit compare value. Each of the counter channels can be used as a PWM output.

The **sleep timer** is an ultralow-power timer that counts 32-kHz crystal oscillator or 32-kHz RC oscillator periods. The sleep timer runs continuously in all operating modes except power mode 3 (PM3). Typical applications of this timer are as a real-time counter or as a wake-up timer to come out of power mode 1 (PM1) or 2 (PM2).

The **ADC** supports 7 to 12 bits of resolution in a 30 kHz to 4 kHz bandwidth, respectively. DC and audio conversions with up to eight input channels (Port 0) are possible. The inputs can be selected as single-ended or differential. The reference voltage can be internal, AVDD, or a single-ended or differential external signal. The ADC also has a temperature-sensor input channel. The ADC can automate the process of periodic sampling or conversion over a sequence of channels.

The **operational amplifier** is intended to provide front-end buffering and gain for the ADC. Both inputs as well as the output are available on pins, so the feedback network is fully customizable. A chopper-stabilized mode is available for applications that need good accuracy with high gain.

The ultralow-power **analog comparator** enables applications to wake up from PM2 or PM3 based on an analog signal. Both inputs are brought out to pins; the reference voltage must be provided externally. The comparator output is connected to the I/O controller interrupt detector and can be treated by the MCU as a regular I/O pin interrupt.

The **random-number generator** uses a 16-bit LFSR to generate pseudorandom numbers, which can be read by the CPU or used directly by the command strobe processor. It can be seeded with random data from noise in the radio ADC.

The **AES encryption/decryption core** allows the user to encrypt and decrypt data using the AES algorithm with 128-bit keys. The core is able to support the AES operations required by IEEE 802.15.4 MAC security, the ZigBee network layer, and the application layer.

A built-in **watchdog timer** allows the CC2530 to reset itself in case the firmware hangs. When enabled by software, the watchdog timer must be cleared periodically; otherwise, it resets the device when it times out. It can alternatively be configured for use as a general 32-kHz timer.

USART 0 and USART 1 are each configurable as either a SPI master/slave or a UART. They provide double buffering on both RX and TX and hardware flow control and are thus well suited to high-throughput full-duplex applications. Each has its own high-precision baud-rate generator, thus leaving the ordinary timers free for other uses.



Note that peripheral units have two alternative locations for their I/O pins; see Table 3-1. Priority can be set between peripherals if conflicting settings regarding I/O mapping are present . All combinations not causing conflicts can be used.

Periphery/ Function	P0								P1								P2				
	7	6	5	4	3	2	1	0	7	6	5	4	3	2	1	0	4	3	2	1	0
ADC	A7	A6	A5	A4	A3	A2	A1	A0													T
Operational amplifier						O	-	+													
Analog comparator			+	-																	
USART 0 SPI			C	SS	MO	MI															
Alt. 2											MO	MI	C	SS							
USART 0 UART			RT	CT	TX	RX															
Alt. 2											TX	RX	RT	CT							
USART 1 SPI			MI	MO	C	SS															
Alt. 2									MI	MO	C	SS									
USART 1 UART			RX	TX	RT	CT															
Alt. 2									RX	TX	RT	CT									
TIMER 1		4	3	2	1	0															
Alt. 2	3	4												0	1	2					
TIMER 3												1	0								
Alt. 2									1	0											
TIMER 4															1	0					
Alt. 2																		1			0
32-kHz XOSC																	Q1	Q2			
DEBUG																			DC	DD	
OBSSSEL											5	4	3	2	1	0					

Table 3-1: DFZM-TS2xx Peripheral I/O Pin Mapping

3-3.Power Management

Different operating modes, or power modes, are used to allow low-power operation. Ultralow-power operation is obtained by turning off the power supply to modules to avoid static (leakage) power consumption and also by using clock gating and turning off oscillators to reduce dynamic power consumption.

The five various operating modes (power modes) are called active mode, idle mode, PM1, PM2, and PM3 (PM1/PM2/PM3 are also referred to as sleep modes). Active mode is the normal operating mode, whereas PM3 has the lowest power consumption. The impact of the different power modes on system operation is shown in Table 3-2, together with voltage regulator and oscillator options.

Power Mode	High-Frequency Oscillator	Low-Frequency Oscillator	Voltage Regulator (Digital)
Configuration	A: 32MHz XOSC B: 16MHz RCOSC	C: 32KHz XOSC D: 32KHz RCOSC	
Active/idle mode	A or B	C or D	ON
PM1	OFF	ON	ON
PM2	OFF	ON	OFF
PM3	OFF	OFF	OFF

Table 3-2: DFZM-TS2xx Power Management

Active mode: The fully functional mode of operation where the CPU, peripherals, and RF transceiver are active. The voltage regulator to the digital core is on, and either the 16MHz RC oscillator or the 32MHz crystal oscillator or both is running. Either the 32KHz RCOSC or the 32KHz XOSC is running.

Idle mode: Identical to active mode, except that the CPU core stops operating (is idle). All other peripherals function normally, and any enabled interrupt wakes up the CPU core (to transition back from idle mode to active mode).

PM1: The voltage regulator to the digital part is on. Neither the 32MHz XOSC nor the 16MHz RCOSC is running. Either the 32KHz RCOSC or 32KHz XOSC is running. When PM1 is entered, a power-down sequence is run.

PM1 is used when the expected time until a wakeup event is relatively short (less than 3 ms), because PM1 uses a fast power-down/up sequence.

PM2: The voltage regulator to the digital core is turned off. Neither the 32MHz XOSC nor the 16MHz RCOSC is running. Either the 32KHz RCOSC or the 32KHz XOSC is running. PM2 has the second-lowest power consumption. In PM2, the power-on reset, external interrupts, selected 32KHz oscillator, and Sleep Timer peripherals are active. I/O pins retain the I/O mode and output value set before entering PM2. All other internal circuits are powered down. The voltage regulator is also turned off. When PM2 is entered, a power-down sequence is run.

PM2 is typically entered when using the Sleep Timer as the wakeup event, and also combined with external interrupts. PM2 should typically be chosen, compared to PM1, when expected sleep time exceeds 3 ms. Using less sleep time does not reduce system power consumption compared to using PM1.

PM3: The voltage regulator to the digital core is turned off. None of the oscillators is running. PM3 is used to achieve the operating mode with the lowest power consumption. In PM3, all internal circuits that are powered from the voltage regulator are turned off (basically all digital modules; the only exceptions are interrupt detection and POR level sensing).

Reset (POR or external) and external I/O port interrupts are the only functions that operate in this mode. I/O pins retain the I/O mode and output value set before entering PM3. A reset condition or an enabled external I/O interrupt event wakes the device up and places it into active mode (an external interrupt starts from where it entered PM3, whereas a reset returns to start-of-program execution). The content of RAM and registers is partially preserved in this mode. PM3 uses the same power-down/up sequence as PM2.

PM3 is used to achieve ultralow power consumption when waiting for an external event. It should be used when expected sleep time exceeds 3 ms.

4. Pin-out and Signal Description

4-1. Device Pin-out Diagram (Module top view)

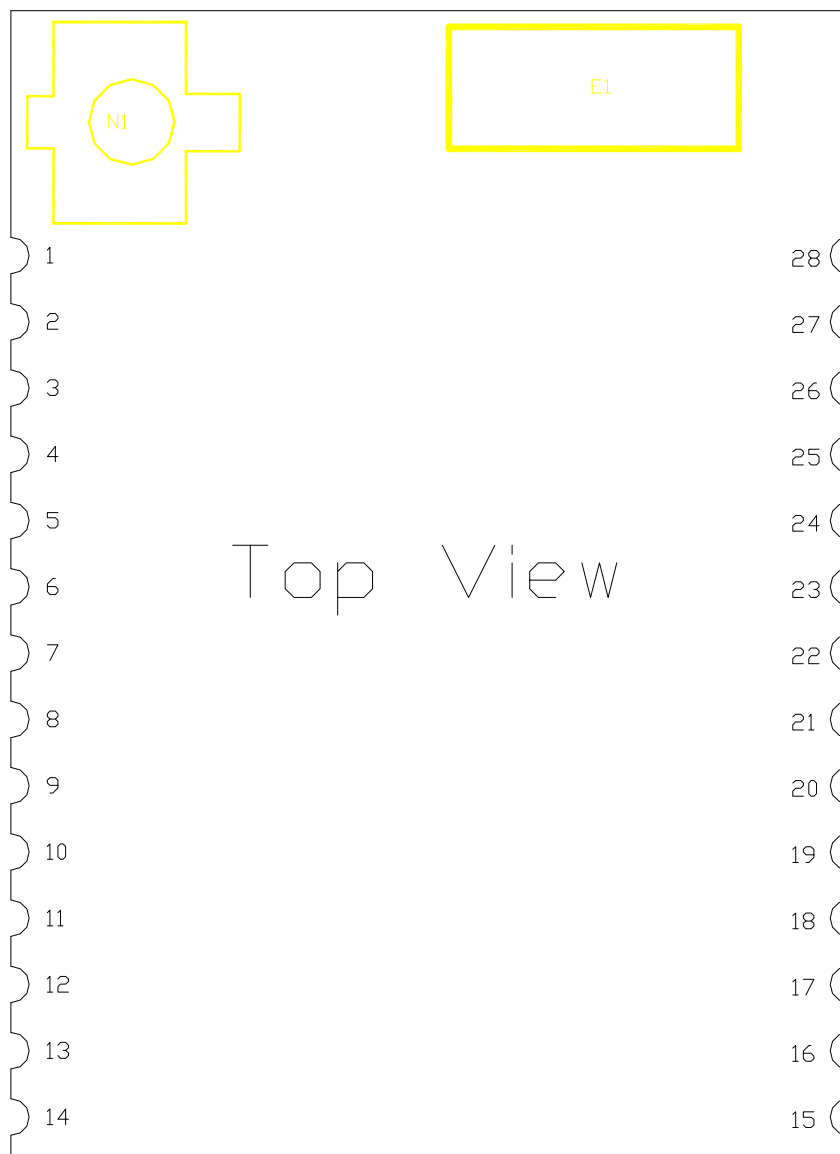

Figure 4-1: DFZM-TS2xx Device Pin-out Diagram (Module top view)

4-2.Module Pins Description

Pins	Name	Pin Type	Description
1	GND	Ground	Ground
2	GND	Ground	Ground
3	GND	Ground	Ground
4	P2_2	Digital I/O	Port 2.2, Debug Clock
5	P2_1	Digital I/O	Port 2.1, Debug Data
6	P2_0	Digital I/O	Port 2.0
7	P1_7	Digital I/O	Port 1.7
8	P1_6	Digital I/O	Port 1.6
9	P1_5	Digital I/O	Port 1.5
10	P1_4	Digital I/O	Port 1.4 (Not available for DFZM-TS21X-DT0R)
11	P1_3	Digital I/O	Port 1.3
12	P1_2	Digital I/O	Port 1.2
13	P1_1	Digital I/O	Port 1.1 (Not available for DFZM-TS21X-DT0R)
14	P1_0	Digital I/O	Port 1.0
15	GND	Ground	Ground
16	GND	Ground	Ground
17	RESET_N	Digital Input	Reset, Active low
18	P0_0	Digital I/O	Port 0.0
19	P0_1	Digital I/O	Port 0.1
20	P0_2	Digital I/O	Port 0.2
21	P0_3	Digital I/O	Port 0.3
22	P0_4	Digital I/O	Port 0.4
23	P0_5	Digital I/O	Port 0.5
24	P0_6	Digital I/O	Port 0.6
25	P0_7	Digital I/O	Port 0.7 (Not available for DFZM-TS21X-DT0R)
26	VCC	Power	Power Supply Input
27	VCC	Power	Power Supply Input



DFZM-TS2xx

28	GND	Ground	Ground
----	-----	--------	--------

5. Electrical Characteristics

5-1. Absolute Maximum Rating

Conditions beyond those cited in Table 5-1 may cause permanent damage to the DFZM-TS2xx, and must be avoided.

Parameter	Minimum	Maximum	Unit
Supply voltage(VCC)	-0.3	3.9	V
Storage temperature range	-40	125	°C
Voltage on any digital I/O	-0.3	VCC+0.3, ≤3.9	V

Table 5-1: Absolute Maximum Ratings

5-2. Recommended Operating Conditions

Parameter	Minimum	Maximum	Unit
Operating supply voltage(VCC)	2	3.6	V
Operating ambient temperature range(T _A)	-40	85	°C

Table 5-2: Recommended Operating Conditions

5-3. Power Consumption

Test Conditions: T_A=25 °C, VCC=3.0V

Parameter	Test conditions	Mim	Typ	Max	Unit
I _{core} Core current consumption	Digital regulator on. 16MHz RCOSC running. No radio, crystals, or peripherals active. Medium CPU activity: normal flash access(1), no RAM access		3.4		mA
	32MHz XOSC running. No radio or peripherals active.		6.5	8.9	mA



DFZM-TS2xx

		Medium CPU activity: normal flash access(1), no RAM access				
		32MHz XOSC running, radio in RX mode, -50dBm input power, no peripherals active, CPU idle@DFZM-TS22x		20.5		mA
		32MHz XOSC running, radio in RX mode, -50dBm input power, no peripherals active, CPU idle@DFZM-TS21x		24		mA
		32MHz XOSC running, radio in RX mode at -100dBm input power (waiting for signal), no peripherals active, CPU idle@DFZM-TS22x	23	25	29.6	mA
		32MHz XOSC running, radio in RX mode at -100dBm input power (waiting for signal), no peripherals active, CPU idle@DFZM-TS21x	27	31	35	mA
		32MHz XOSC running, radio in TX mode, 4.5dBm output power, no peripherals active, CPU idle@DFZM-TS22x	34	36	39.6	mA
		32MHz XOSC running, radio in TX mode, 18.5dBm output power, no peripherals active, CPU idle@DFZM-TS21x	150	168	190	mA
		Power mode 1. Digital regulator on; 16MHz RCOSC and 32MHz crystal oscillator off; 32.768kHz XOSC, POR, BOD and sleep timer active; RAM and register retention		0.2	0.3	uA
		Power mode 2. Digital regulator off; 16MHz RCOSC and 32MHz crystal oscillator off; 32.768kHz XOSC, POR, and sleep timer active; RAM and register retention		1	2	uA
		Power mode 3. Digital regulator off; no clocks; POR active; RAM and register retention		0.4	1	uA
I _{per} Peripheral current consumption (Adds to core current I _{core} for each peripheral unit activated)	Timer 1	Timer running, 32MHz XOSC used		90		uA
	Timer2	Timer running, 32MHz XOSC used		90		uA
	Timer 3	Timer running, 32MHz XOSC used		60		uA
	Timer 4	Timer running, 32MHz XOSC used		70		uA
	Sleep timer	Including 32.753-kHz RCOSC		0.6		uA
	ADC	When converting		1.2		mA
	Flash	Erase		1		mA

	Burst write peak current		6		mA
--	--------------------------	--	---	--	----

Table 5-3: Poewr Consumption

(1) Normal flash access means that the code used exceeds the cache storage, so cache misses happen frequently.

5-4.DC Characteristics

Test Conditions: $T_A=25\text{ }^\circ\text{C}$, $V_{CC}=3.0\text{V}$

Parameter	Test conditions	Min	Typ	Max	Unit
Logic-0 input voltage				0.5	V
Logic-1 input voltage		2.5			V
Logic-0 input current	Input equals 0 V	-50		50	nA
Logic-1 input current	Input equals VDD	-50		50	nA
I/O-pin pullup and pulldown resistors			20		k Ω
Logic-0 output voltage, 4-mA pins	Output load 4 mA			0.5	V
Logic-1 output voltage, 4-mA pins	Output load 4 mA	2.4			V
Logic-0 output voltage, 20-mA pins	Output load 20 mA			0.5	V
Logic-1 output voltage, 20-mA pins	Output load 20 mA	2.4			V

Table 5-4: DC Characteristics

5-5.Wake-up and Timing

Test Conditions: $T_A=25\text{ }^\circ\text{C}$, $V_{CC}=3.0\text{V}$

Parameter	Test conditions	Min	Typ	Max	Unit
Power mode 1 \rightarrow active	Digital regulator on, 16-MHz RCOSC and 32-MHz crystal oscillator off. Start-up of 16-MHz RCOSC		4		us
Power mode 2 or 3 \rightarrow active	Digital regulator off, 16-MHz RCOSC and 32-MHz crystal oscillator off. Start-up of regulator and 16-MHz RCOSC		0.1		ms
Active \rightarrow TX or RX	Initially running on 16-MHz RCOSC, with 32-MHz XOSC OFF		0.5		ms

Parameter	Test conditions	Min	Typ	Max	Unit
	With 32-MHz XOSC initially on			192	us
RX/TX and TX/RX turnaround				192	us

Table 5-5: Wake-up and Timing

5-6.Radio Parameters

Test Conditions: $T_A=25\text{ }^\circ\text{C}$, $V_{CC}=3.0\text{V}$

Parameter	Min	Typ	Max	Unit	Notes
RF Frequency range	2394		2507	MHz	
Radio baud rate		250		Kbps	
Radio chip rate		2		Mchip/s	
Flash erase cycles			20	K cycles	
Flash page size		2		KB	
TX/RX specification for DFZM-TS22x					
Output power	2	3.2	4.5	dBm	
Error vector magnitude (EVM)		2		%	
Frequency error tolerance	-30	0	30	ppm	
Receiver sensitivity	-100	-99	-97	dBm	PER = 1%,
Saturation(Maximum input level)		10		dBm	PER = 1%,
TX/RX specification for DFZM-TS21x					
Output power	16	18.5	21	dBm	
Error vector magnitude (EVM)		2		%	
Frequency error tolerance	-30	0	30	ppm	
Receiver sensitivity	-100	-99	-97	dBm	PER = 1%,
Saturation(Maximum input level)		10		dBm	PER = 1%,

Table 5-6: Radio Parameters

5-7.ADC Parameters

Test Conditions: $T_A=25\text{ }^\circ\text{C}$, $V_{CC}=3.0\text{V}$

Parameter	Test Condition	Min	Typ	Max	Unit
Input voltage		0		VCC	V
External reference voltage		0		VCC	V
External reference voltage differential		0		VCC	V
Input resistance, signal	Using 4-MHz clock speed		197		k Ω
Full-scale signal(1)	Peak-to-peak, defines 0 dBFS		2.97		V
ENOB(1) Effective number of bits	Single-ended input, 7-bit setting		5.7		bits
	Single-ended input, 9-bit setting		7.5		
	Single-ended input, 10-bit setting		9.3		
	Single-ended input, 12-bit setting		10.8		
	Differential input, 7-bit setting		6.5		
	Differential input, 9-bit setting		8.3		
	Differential input, 10-bit setting		10.0		
	Differential input, 12-bit setting		11.5		
Useful power bandwidth	7-bit setting, both single and differential	0		20	KHz
THD(1)	Single-ended input, 12-bit setting, -6 dBFS		-75.2		dB
Total harmonic distortion	Differential input, 12-bit setting, -6 dBFS		-86.6		
Signal to nonharmonic ratio(1)	Single-ended input, 12-bit setting		70.2		dB
	Differential input, 12-bit setting		79.3		
	Single-ended input, 12-bit setting, -6 dBFS		78.8		
	Differential input, 12-bit setting, -6 dBFS		88.9		
CMRR Common-mode rejection ratio	Differential input, 12-bit setting, 1-kHz sine (0 dBFS), limited by ADC resolution	84			dB
Crosstalk	Differential input, 12-bit setting, 1-kHz sine (0	84			dB

	dBFS), limited by ADC resolution				
Offset	Midscale		-3		mV
Gain error			0.68		%
DNL(1)	12-bit setting, mean		0.05		LSB
Differential nonlinearity	12-bit setting, maximum		0.9		
INL(1)	12-bit setting, mean		4.6		LSB
Integral nonlinearity	12-bit setting, maximum		13.3		
SINAD(1) (-THD+N) Signal-to-noise-and-distortion	Single-ended input, 7-bit setting		35.4		dB
	Single-ended input, 9-bit setting		46.8		
	Single-ended input, 10-bit setting		57.5		
	Single-ended input, 12-bit setting		66.6		
	Differential input, 7-bit setting		40.7		
	Differential input, 9-bit setting		51.6		
	Differential input, 10-bit setting		61.8		
	Differential input, 12-bit setting		70.8		
Conversion time	7-bit setting		20		us
	9-bit setting		36		
	10-bit setting		68		
	12-bit setting		132		
Internal reference voltage			1.15		mA
Internal reference VCC coefficient			4		mV/V
Internal reference temperature coefficient			0.4		mV/10°C

Table 5-7: ADC Parameters

(1) Measured with 300-Hz sine-wave input and VCC as reference.

5-8.SPI AC Characteristics

Test Conditions: $T_A = -40 \sim 85 \text{ }^\circ\text{C}$, $V_{CC} = 2.0 \sim 3.6\text{V}$

Parameter	Test conditions	Min	Typ	Max	Unit
t1 SCK period	Master, RX and TX	250			ns
	Slave, RX and TX	250			
SCK duty cycle	Master		50		%
t2 SSN low to SCK	Master	63			ns
	Slave	63			
t3 SCK to SSN high	Master	63			ns
	Slave	63			
t4 MOSI early out	Master, load = 10 pF			7	ns
t5 MOSI late out	Master, load = 10 pF			10	ns
t6 MISO setup	Master	90			ns
t7 MISO hold	Master	10			ns
SCK duty cycle	Slave		50		%
t10 MOSI setup	Slave	35			ns
t11 MOSI hold	Slave	10			ns
t9 MISO late out	Slave, load = 10 pF			95	ns
Operating frequency	Master, TX only			8	MHz
	Master, RX and TX			4	
	Slave, RX only			8	
	Slave, RX and TX			4	

Table 5-85: SPI AC Characteristics

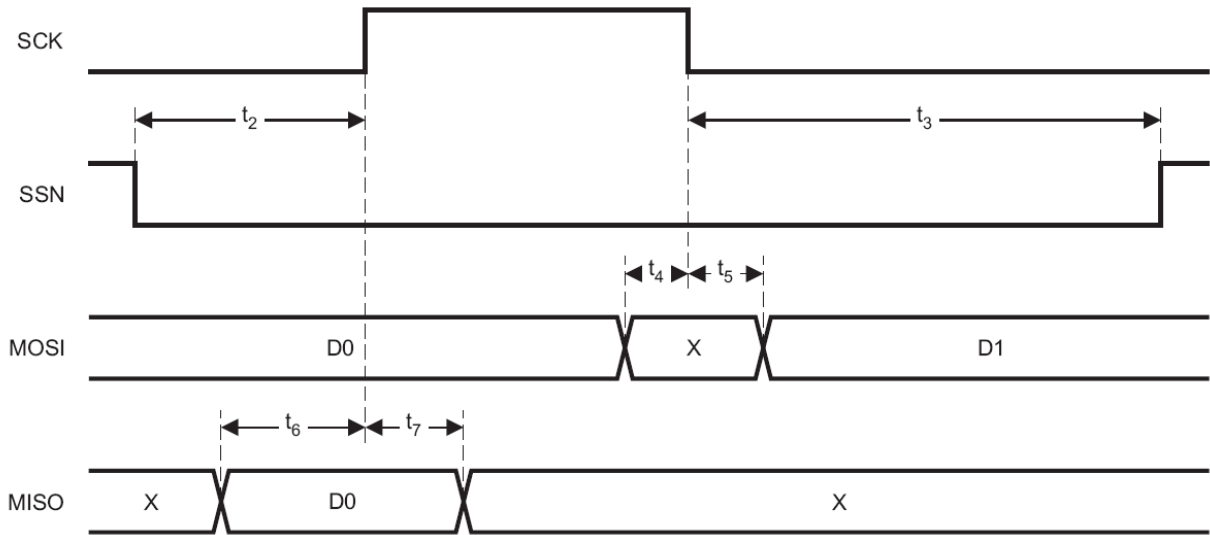

Figure 5-1: SPI Master AC Characteristics

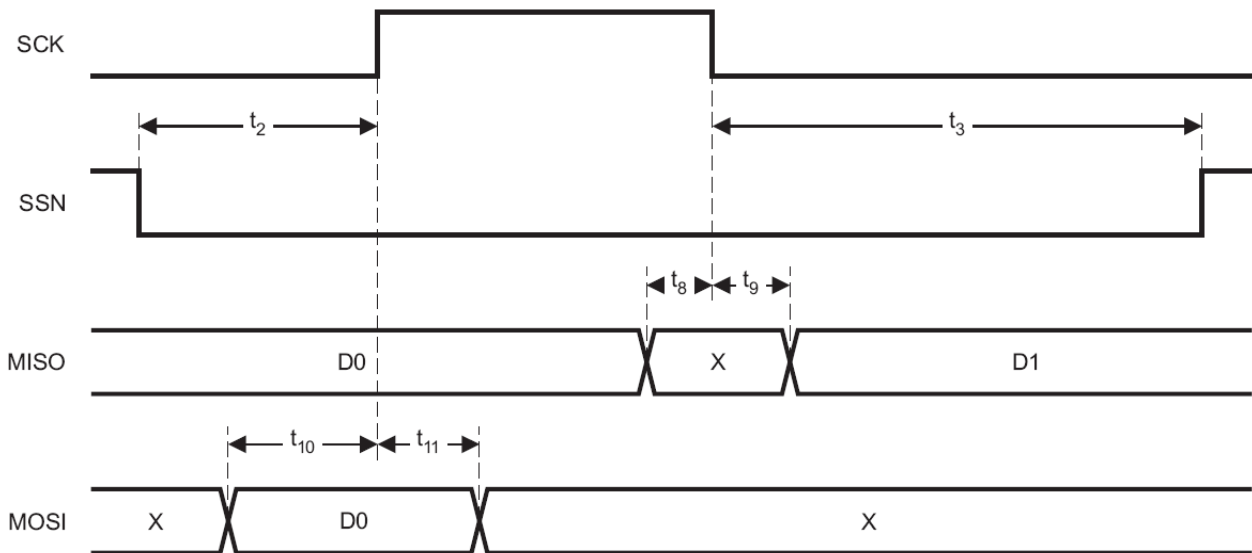

Figure 5-2: SPI Slave AC Characteristics

6. Package and Layout Guidelines

6-1.Recommended PCB Footprint and Dimensions

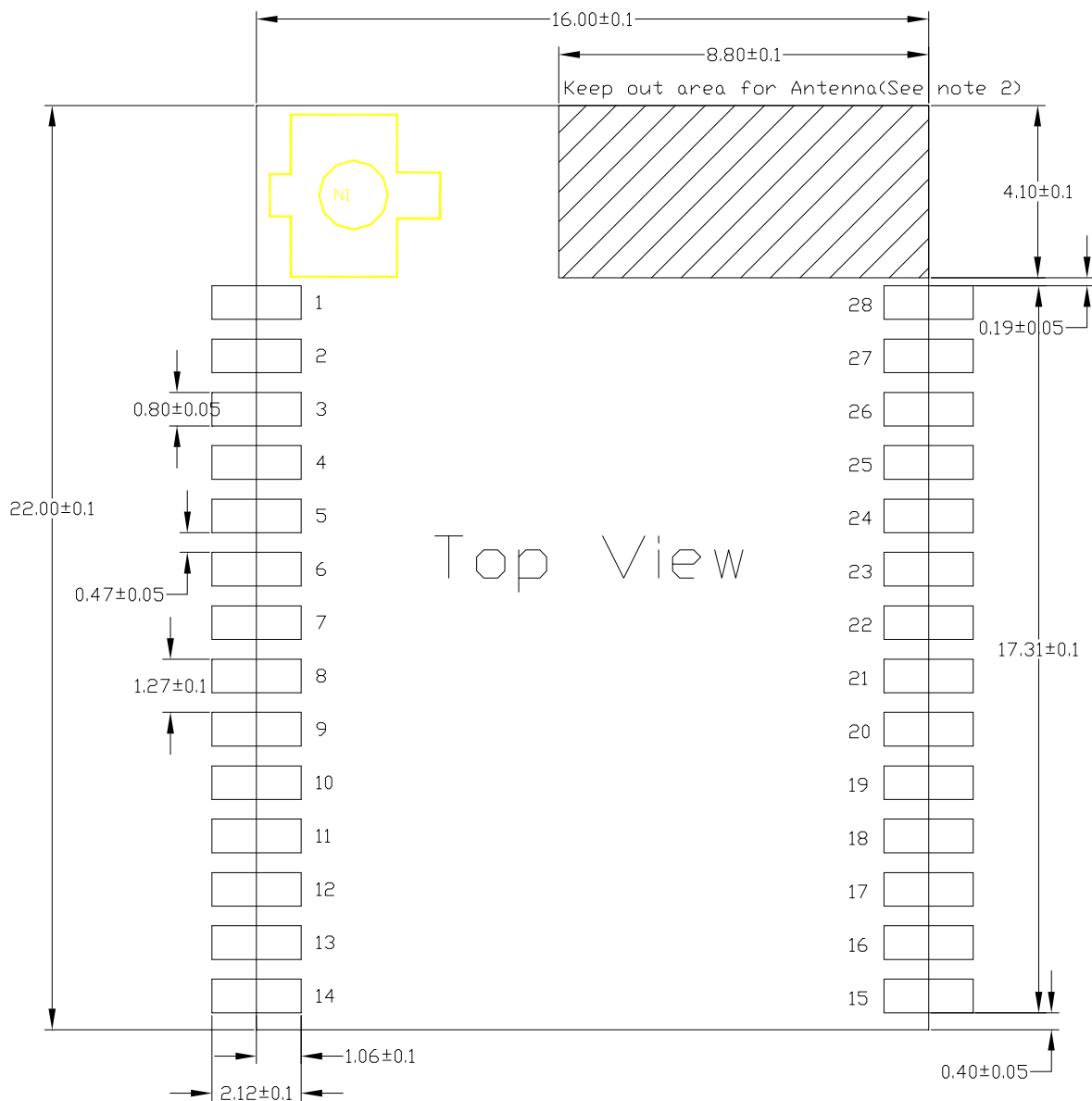

Figure 6-1: DFZM-TS2xx Module Recommended PCB Footprint (in mm)

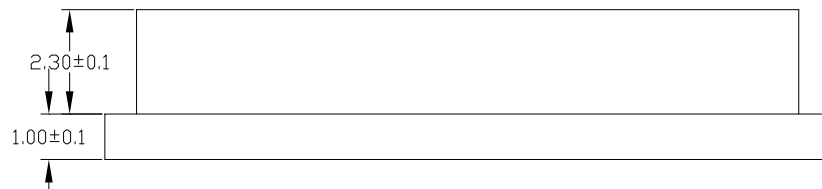
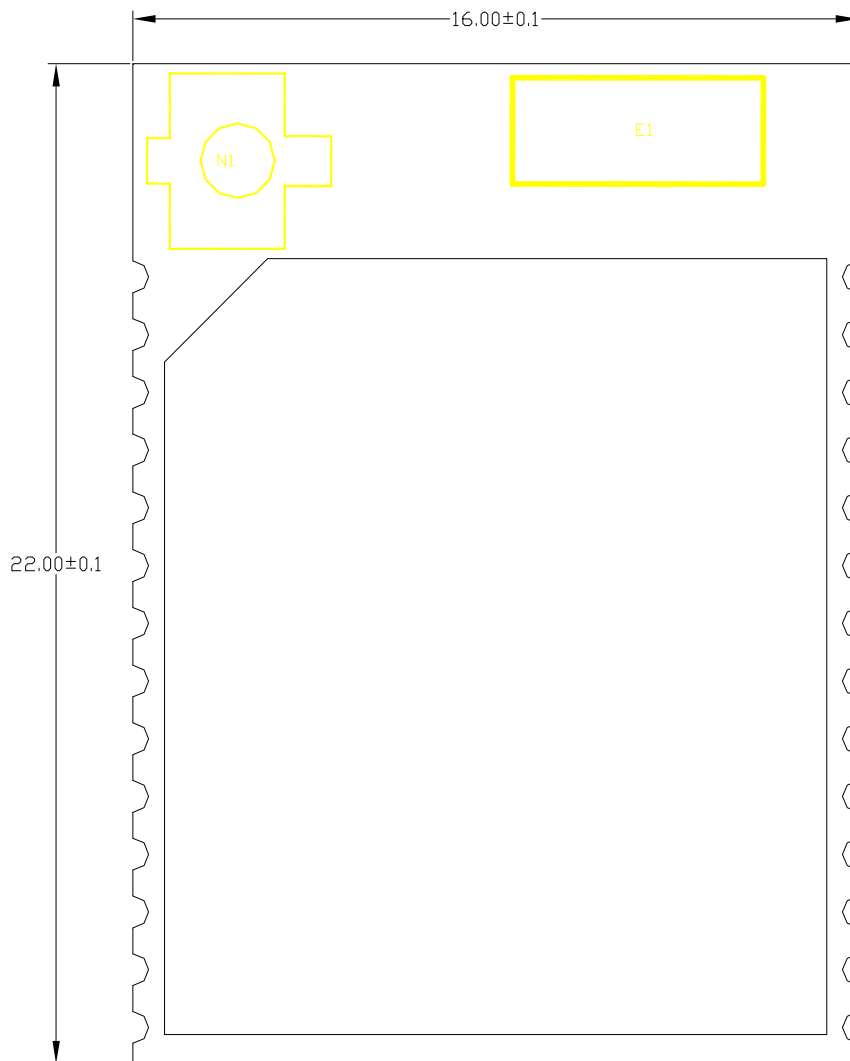

Figure 6-2: DFZM-TS22x Module Dimensions (in mm)

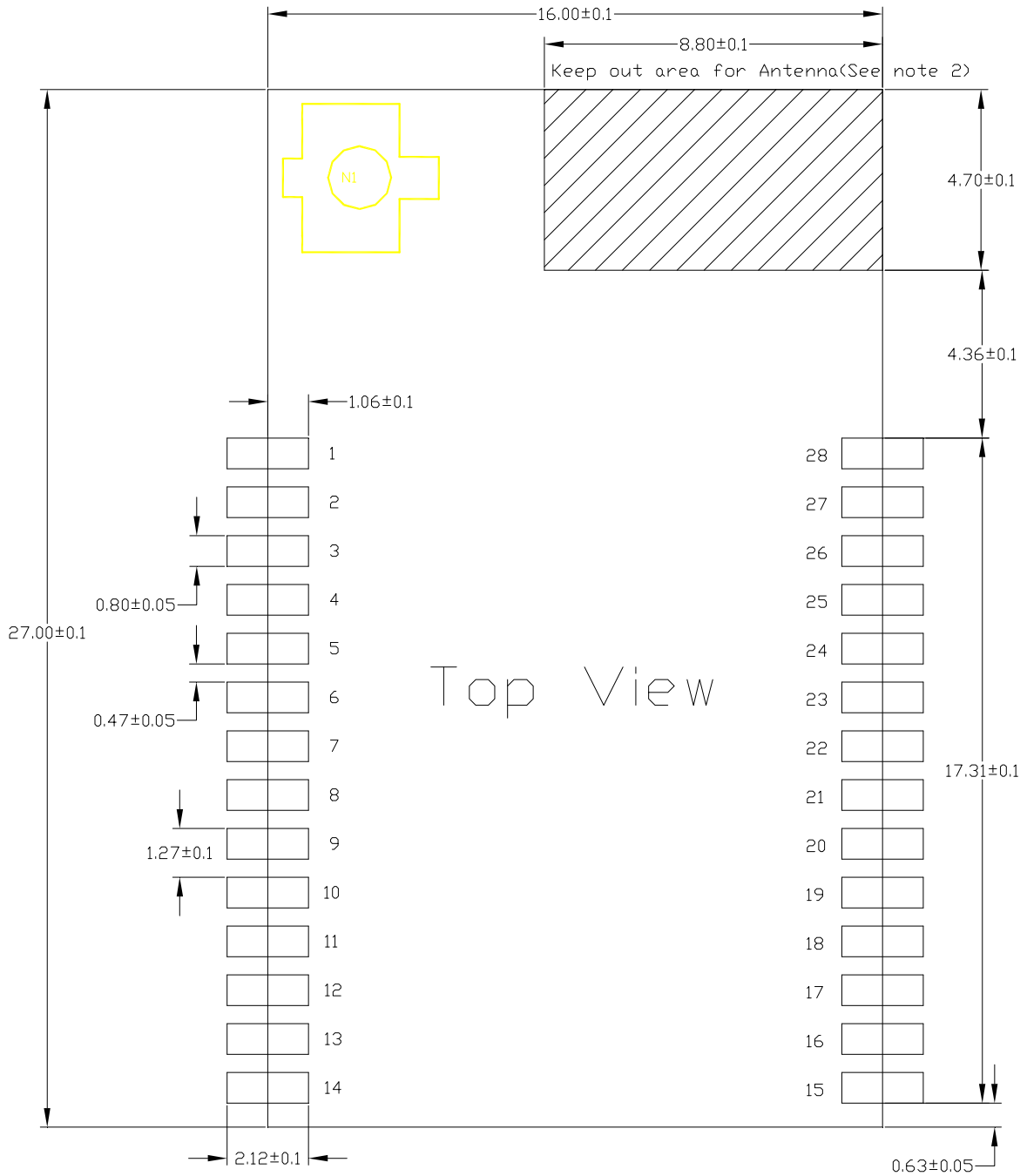

Figure 6-3: DFZM-TS21x Module Recommended PCB Footprint (in mm)

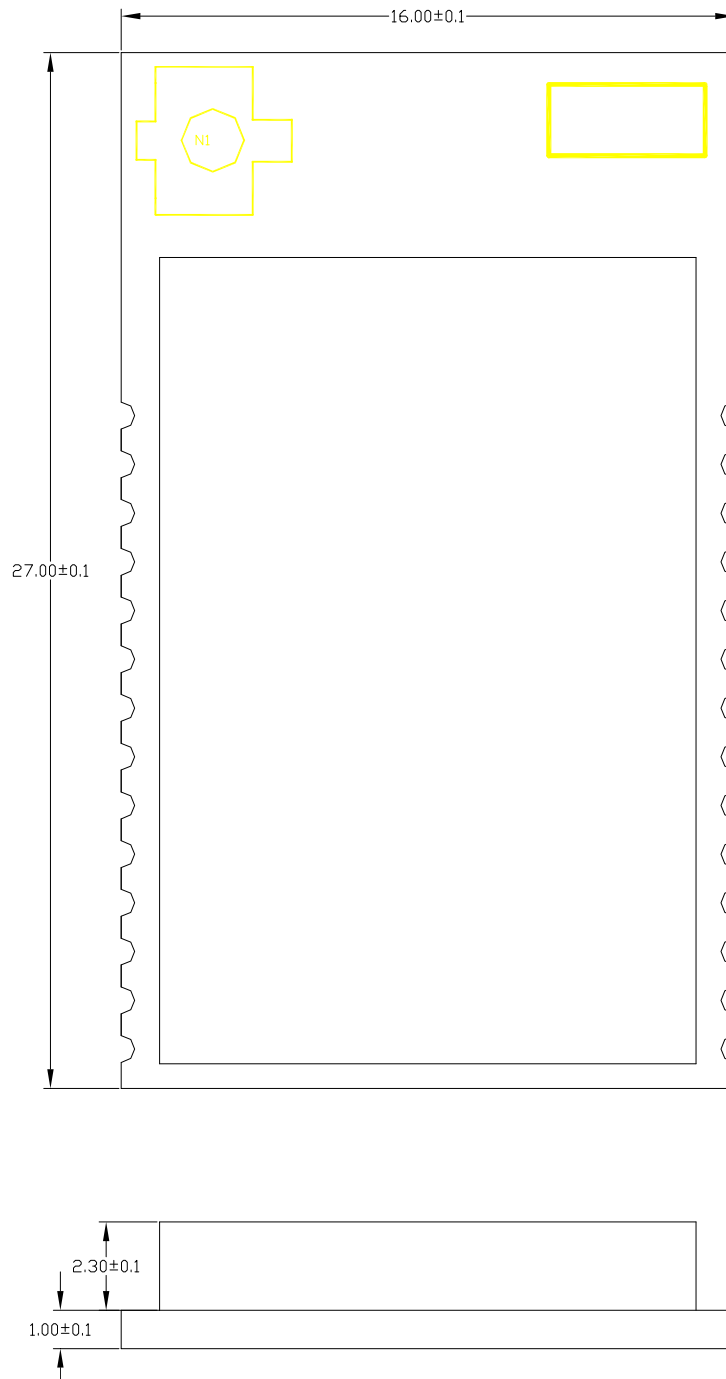
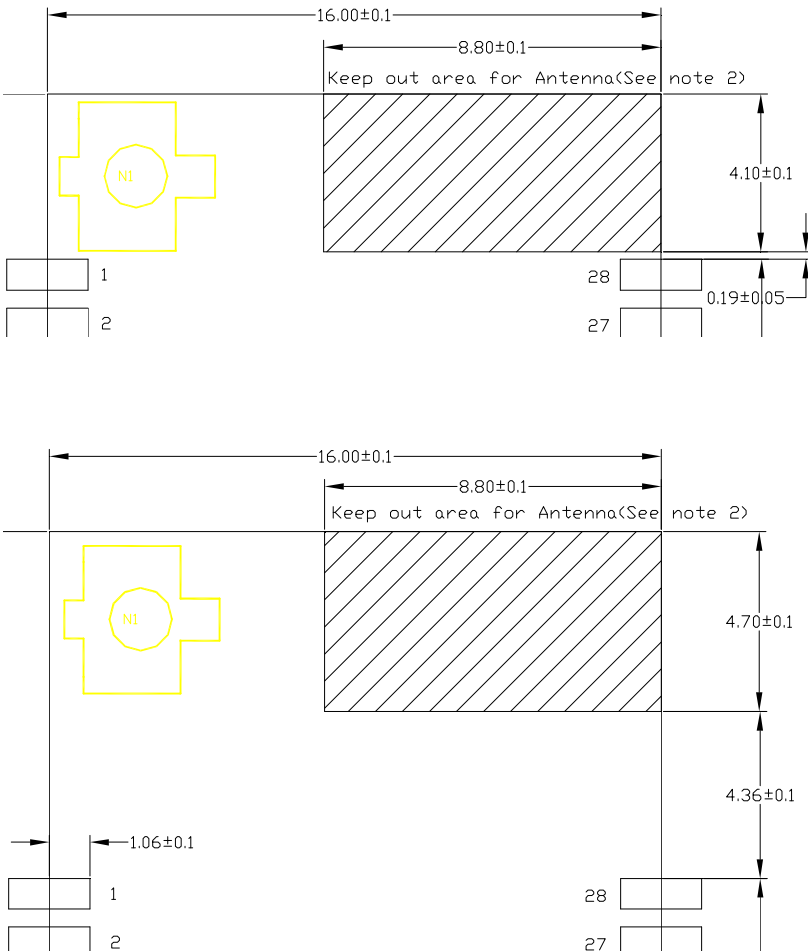

Figure 6-4: DFZM-TS21x Module Dimensions (in mm)

6-2.Layout Guidelines



Keep out area for onboard chip antenna. All layers on the PCB must be clear.

(i.e. No GND, Power trace/plane, traces.)

Note1: If guidelines are not followed, DFZM-TS2xx range with onboard chip antenna will be compromised.

Note2: If the user has accounted for power consumption, module outline and onboard chip antenna keep out for DFZM-TS221, then DFZM-TS211 can also be accommodated on the same end application board footprint.

Figure 6-5: DFZM-TS2xx module onboard antenna keep-out layout guidelines (in mm)

If application baseboard is being designed to accommodate both DFZM-TS221 and DFZM-TS211, then customer may follow the recommendation as shown in

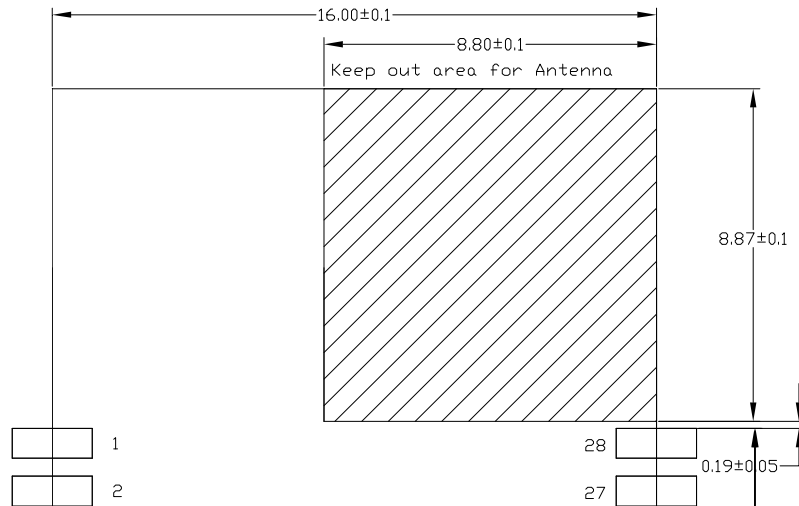

Figure 6-6: Recommended keep out area to accommodate both DFZM-TS221 and DFZM-TS211

Notes:

1. All Dimensions are in mm. Tolerances shall be ± 0.10 mm.
2. Absolutely no metal trace or ground layer underneath this area.
3. It is recommended not to run circuit traces underneath the module.
4. In performing SMT or manual soldering of the module to the base board, please align the two row of pins.

In addition to the guidelines in Figure 6-6, note the following suggestions:

DFZM-TS22x and DFZM-TS21x

- External Bypass capacitors for all module supplies should be as close as possible to the module pins.
- Never place the antenna very close to metallic objects.
- The external dipole antennas need a reasonable ground plane area for antenna efficiency.

DFZM-TS221; DFZM-TS211 onboard chip antenna specific

- The onboard chip antenna keep out area, as shown in Figure 6-5, must be adhered to. In addition it is recommended to have clearance above and below the PCB trace antenna (Figure 6-7) for optimal range performance.

- Do not use a metallic or metalized plastic for the end product enclosure.
- Recommendation is to keep plastic enclosure clearance of 1cm from top and bottom of the DFZM-TS2xx onboard chip antenna keep-out area, if possible. 5-mm (0.2 in) clearance shall be the minimum as shown in Figure 6-7.

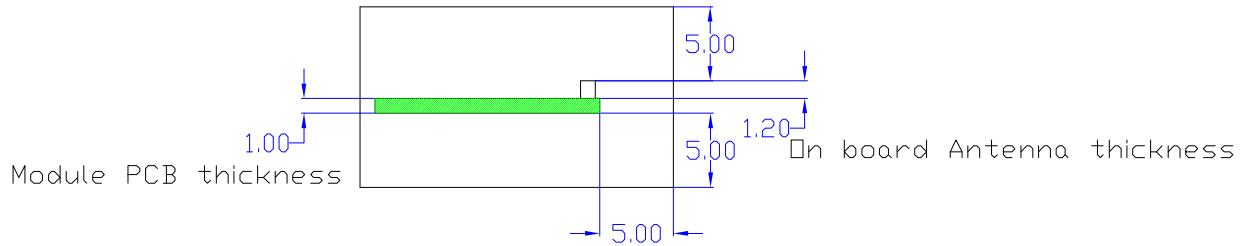

Figure 6-7 Recommended clearance above and below the PCB trace antenna

6-2-1. Surface Mount Assembly

The reflow profile is shown in Figure 6-8.

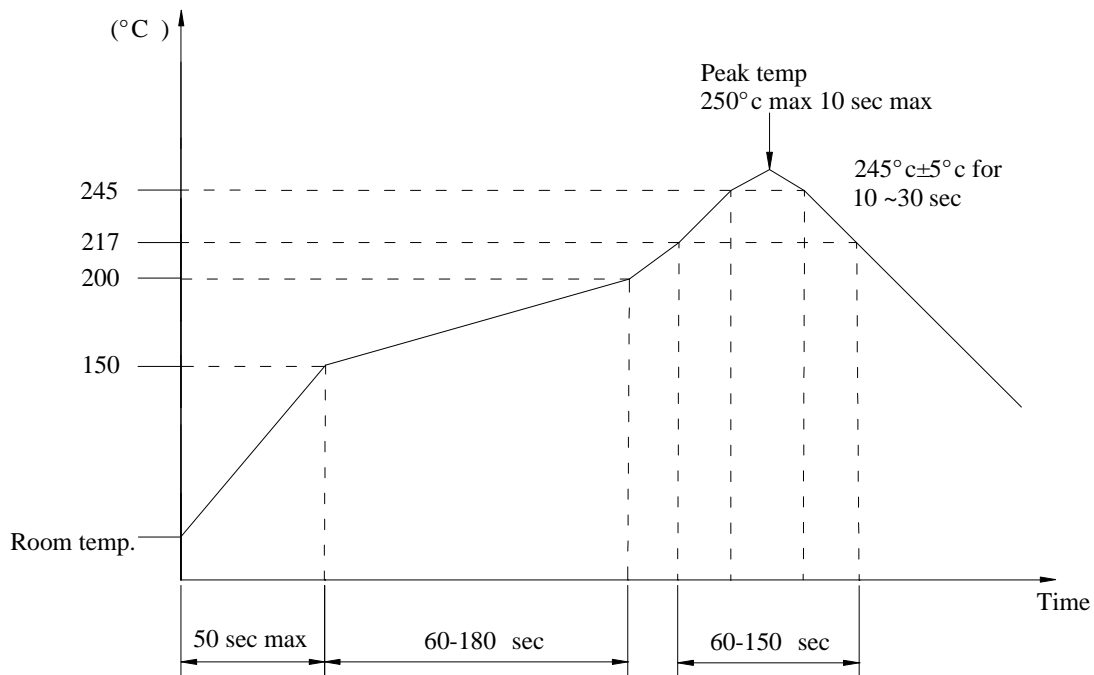

Figure 6-8: Reflow temperature profile

Note:

1. Perform adequate test in advance as the reflow temperature profile will vary accordingly to the conditions of the parts and boards, and the specifications of the reflow furnace.
2. Be careful about rapid temperature rise in preheat zone as it may cause excessive slumping of the solder paste.
3. If the preheat is insufficient, rather large solder balls tend to be generated. Conversely, if performed excessively, fine balls and large balls will generate in clusters at a time.
4. If the temperature is too low, non-melting tends to be caused in the area with large heat capacity after reflow.
5. Be careful about sudden rise in temperature as it may worsen the slump of solder paste.
6. Be careful about slow cooling as it may cause the positional shift of parts and decline in joining strength at times.

6-3.Recommended Stencil Aperture

Note: The thickness of the stencil should be 0.15mm over this area.

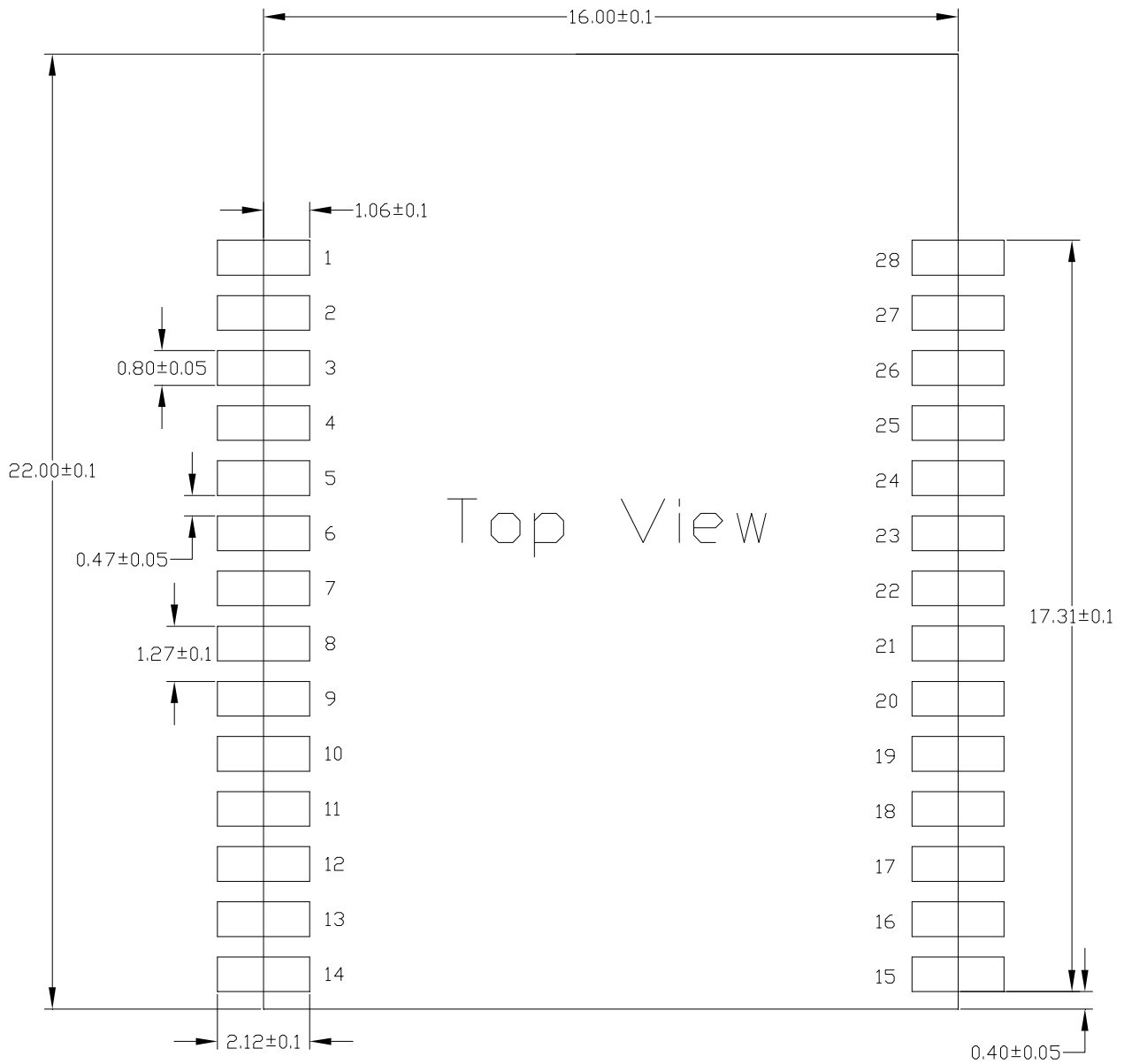

Figure 6-9: DFZM-TS2xx recommended stencil aperture

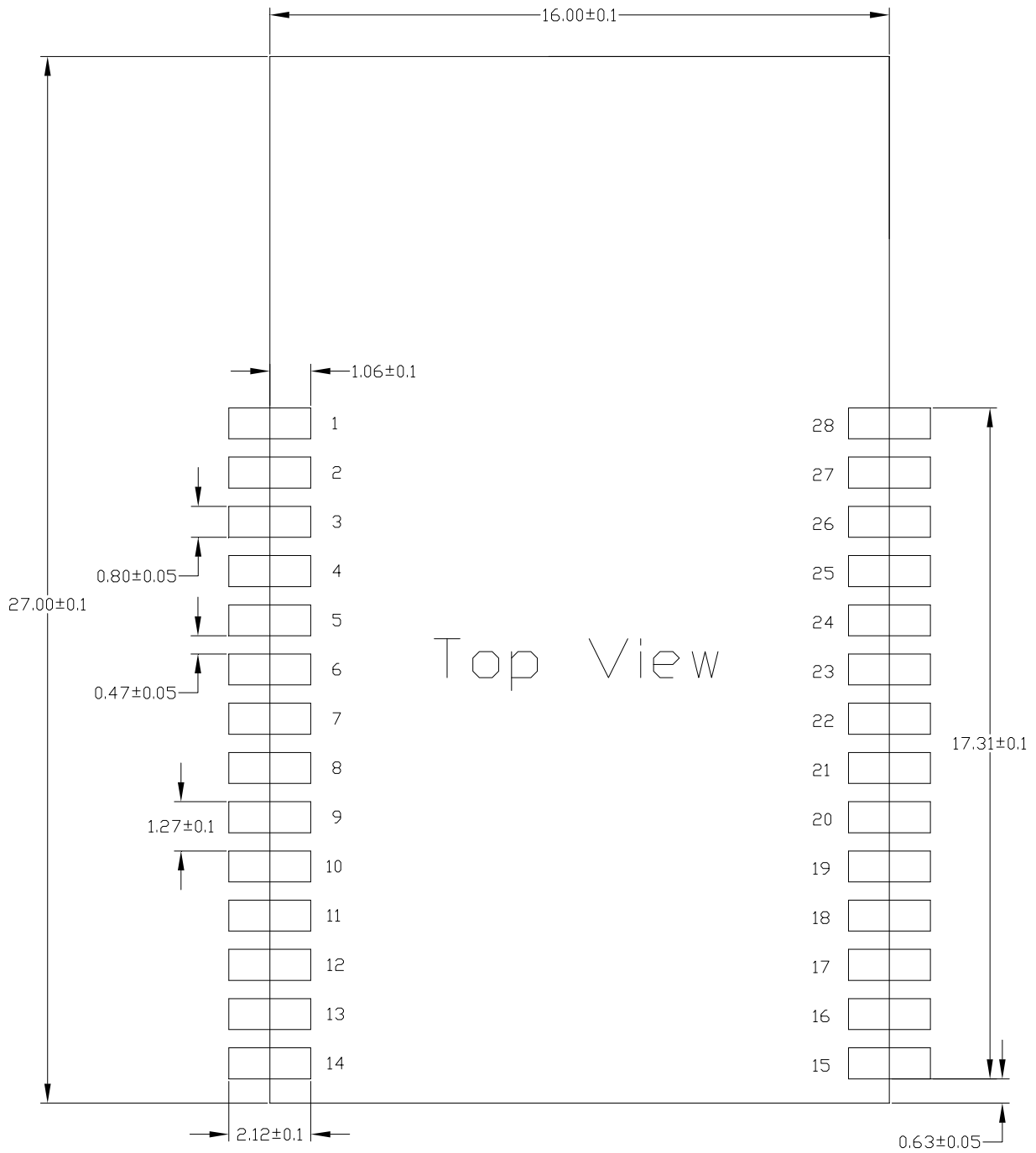

Figure 6-9: DFZM-TS21x recommended stencil aperture

7. Ordering Information

DEVICE DESCRIPTION	ORDERING NUMBER
Extended range module using external antenna	DFZM-TS210-DT0R
Extended range module using onboard chip antenna	DFZM-TS211-DT0R
Low power module using external antenna	DFZM-TS220-DT0R
Low power module using onboard chip antenna	DFZM-TS211-DT0R

8. Federal Communications Commission (FCC)

Statement

15.21

You are cautioned that changes or modifications not expressly approved by the part responsible for compliance could void the user's authority to operate the equipment.

15.105(b)

This equipment has been tested and found to comply with the limits for a Class B digital device, pursuant to part 15 of the FCC rules. These limits are designed to provide reasonable protection against harmful interference in a residential installation. This equipment generates, uses and can radiate radio frequency energy and, if not installed and used in accordance with the instructions, may cause harmful interference to radio communications. However, there is no guarantee that interference will not occur in a particular installation. If this equipment does cause harmful interference to radio or television reception, which can be determined by turning the equipment off and on, the user is encouraged to try to correct the interference by one or more of the following measures:



- Reorient or relocate the receiving antenna.
- Increase the separation between the equipment and receiver.
 - Connect the equipment into an outlet on a circuit different from that to which the receiver is connected.
- Consult the dealer or an experienced radio/TV technician for help.

This device complies with Part 15 of the FCC Rules. Operation is subject to the following two conditions:

- 1) this device may not cause harmful interference, and
- 2) this device must accept any interference received, including interference that may cause undesired operation of the device.

FCC RF Radiation Exposure Statement:

This equipment complies with FCC radiation exposure limits set forth for an uncontrolled environment. End users must follow the specific operating instructions for satisfying RF exposure compliance. This transmitter must not be co-located or operating in conjunction with any other antenna or transmitter.

Note: The end product shall has the words “Contains Transmitter Module **FCC ID:**

“H79DFZM-TS210”

Caution: Exposure to Radio Frequency Radiation.

To comply with FCC RF exposure compliance requirements, a separation distance of at least 20 cm must be maintained between the antenna of this device and all persons.