

Hardware Specification for BSG RF Module

Block Diagram:

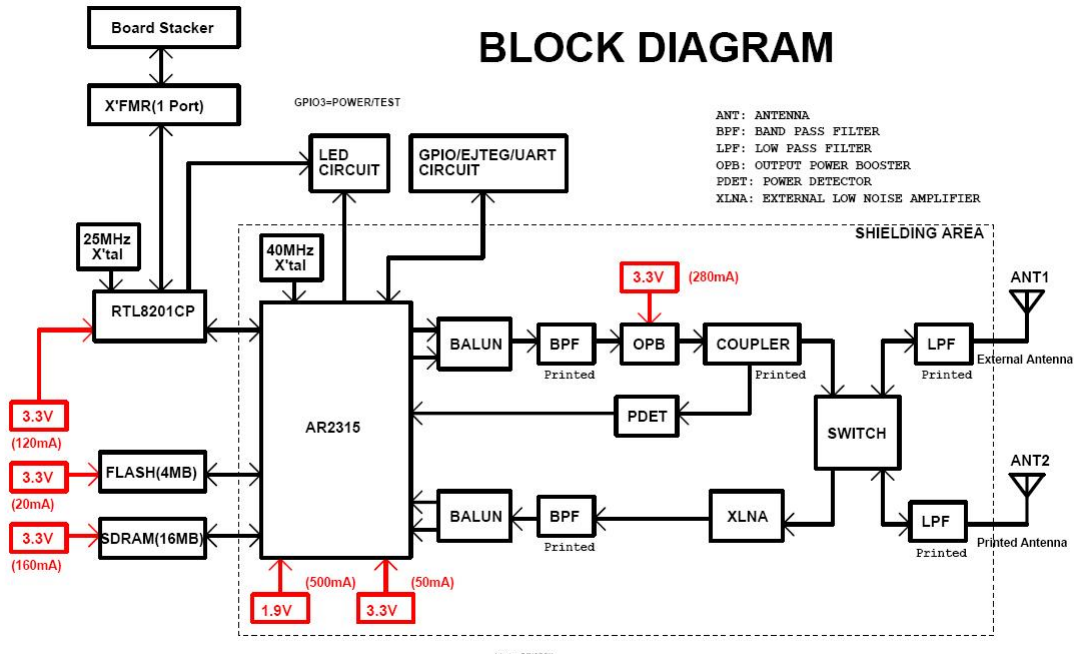

Processor : Atheros AR2315 single chip integrated with the MAC/baseband/radio

PHY : Realtek RTL8201 single channel, full-duplex 10/100Base-Tx transceiver

Memory : Serial Flash : 32Mbit

SDRAM : 16MByte, 16bit data bus – 1 piece of 8M x 16bit.

I/O Interface : FE , 1 x 2.4G RF SMA Conn. attaching to Antenna.

1 x 2.4G Printed Antenna

Feature :

- Wi-fi Wireless Access Point
- IEEE802.11b/g
- 2.4G RF SMA Conn. attaching to Antenna.
- 2.4G Printed Antenna
- Max Transmit power consumption:2.4W
- Rx Sensitivity

	Test Name	Data Rate	DUT Measured
11g	RX Sensitivity	6Mbps	-88
	RX Sensitivity	36Mbps	-73
	RX Sensitivity	48Mbps	-70
	RX Sensitivity	54Mbps	-68
11b	RX Sensitivity	1Mbps	-90
	RX Sensitivity	2Mbps	-87
	RX Sensitivity	5.5Mbps	-86
	RX Sensitivity	11Mbps	-85

■ Transmit Power

	Test Name	Data Rate	DUT Measured
11g	Transmit power	6Mbps	17 (+1.5/-1.5) dBm
	Transmit power	36Mbps	16 (+1.5/-1.5) dBm
	Transmit power	48Mbps	15 (+1.5/-1.5) dBm
	Transmit power	54Mbps	14 (+1.5/-1.5) dBm
11b	Transmit power	1Mbps	17 (+1.5/-1.5) dBm
	Transmit power	2Mbps	17 (+1.5/-1.5) dBm
	Transmit power	5.5Mbps	17 (+1.5/-1.5) dBm
	Transmit power	11Mbps	17 (+1.5/-1.5) dBm

Federal Communication Commission Interference Statement

This equipment has been tested and found to comply with the limits for a Class B digital device, pursuant to Part 15 of the FCC Rules. These limits are designed to provide reasonable protection against harmful interference in a residential installation. This equipment generates, uses and can radiate radio frequency energy and, if not installed and used in accordance with the instructions, may cause harmful interference to radio communications. However, there is no guarantee that interference will not occur in a particular installation. If this equipment does cause harmful interference to radio or television reception, which can be determined by turning the equipment off and on, the user is encouraged to try to correct the interference by one of the following measures:

- Reorient or relocate the receiving antenna.
- Increase the separation between the equipment and receiver.
- Connect the equipment into an outlet on a circuit different from that to which the receiver is connected.
- Consult the dealer or an experienced radio/TV technician for help.

This transmitter must not be co-located or operating in conjunction with any other antenna or transmitter.

This device complies with Part 15 of the FCC Rules. Operation is subject to the following two conditions: (1) This device may not cause harmful interference, and (2) this device must accept any interference received, including interference that may cause undesired operation.

IMPORTANT NOTE:

This module is intended for OEM integrator. The OEM integrator is still responsible for the FCC compliance requirement of the end product, which integrates this module.

20cm minimum distance has to be able to be maintained between the antenna and the users for the host this module is integrated into. Under such configuration, the FCC radiation exposure limits set forth for an population/uncontrolled environment can be satisfied.

Any changes or modifications not expressly approved by the manufacturer could void the user's authority to operate this equipment.

USERS MANUAL OF THE END PRODUCT:

In the users manual of the end product, the end user has to be informed to keep at least 20cm separation with the antenna while this end product is installed and operated. The end user has to be informed that the FCC radio-frequency exposure guidelines for an uncontrolled environment can be satisfied. The end user has to also be informed that any changes or modifications not expressly approved by the manufacturer could void the user's authority to operate this equipment. If the size of the end product is smaller than 8x10cm, then additional FCC part 15.19 statement is required to be available in the users manual: This device complies with Part 15 of FCC rules. Operation is subject to the following two conditions: (1) this device may not cause harmful interference and (2) this device must accept any interference received, including interference that may cause undesired operation.

LABEL OF THE END PRODUCT:

The final end product must be labeled in a visible area with the following " Contains TX FCC ID: XXXXX ". If the size of the end product is larger than 8x10cm, then the following FCC part 15.19 statement has to also be available on the label: This device complies with Part 15 of FCC rules. Operation is subject to the following two conditions: (1) this device may not cause harmful interference and (2) this device must accept any interference received, including interference that may cause undesired operation.