

# 6" Belt / 9" Disc Sander

(Model 31-695)



PART NO. 902122 (0112)  
Copyright © 2001 Delta Machinery



To learn more about DELTA MACHINERY  
visit our website at: [www.deltamachinery.com](http://www.deltamachinery.com).

For Parts, Service, Warranty or other Assistance,

please call **1-800-223-7278** (In Canada call **1-800-463-3582**).

**ESPAÑOL: PÁGINA 21**

# GENERAL SAFETY RULES

Woodworking can be dangerous if safe and proper operating procedures are not followed. As with all machinery, there are certain hazards involved with the operation of the product. Using the machine with respect and caution will considerably lessen the possibility of personal injury. However, if normal safety precautions are overlooked or ignored, personal injury to the operator may result. Safety equipment such as guards, push sticks, hold-downs, featherboards, goggles, dust masks and hearing protection can reduce your potential for injury. But even the best guard won't make up for poor judgment, carelessness or inattention. Always use common sense and exercise caution in the workshop. If a procedure feels dangerous, don't try it. Figure out an alternative procedure that feels safer. **REMEMBER:** Your personal safety is your responsibility.

This machine was designed for certain applications only. Delta Machinery strongly recommends that this machine not be modified and/or used for any application other than that for which it was designed. If you have any questions relative to a particular application, **DO NOT** use the machine until you have first contacted Delta to determine if it can or should be performed on the product.

## Technical Service Manager

Delta Machinery  
4825 Highway 45 North  
Jackson, TN 38305

(IN CANADA: 505 SOUTHGATE DRIVE, GUELPH, ONTARIO N1H 6M7)



## WARNING: FAILURE TO FOLLOW THESE RULES MAY RESULT IN SERIOUS PERSONAL INJURY

1. **FOR YOUR OWN SAFETY, READ INSTRUCTION MANUAL BEFORE OPERATING THE TOOL.** Learn the tool's application and limitations as well as the specific hazards peculiar to it.

2. **KEEP GUARDS IN PLACE** and in working order.

3. **ALWAYS WEAR EYE PROTECTION.** Wear safety glasses. Everyday eyeglasses only have impact resistant lenses; they are not safety glasses. Also use face or dust mask if cutting operation is dusty. These safety glasses must conform to ANSI Z87.1 requirements. **NOTE:** Approved glasses have Z87 printed or stamped on them.

4. **REMOVE ADJUSTING KEYS AND WRENCHES.** Form habit of checking to see that keys and adjusting wrenches are removed from tool before turning it "on".

5. **KEEP WORK AREA CLEAN.** Cluttered areas and benches invite accidents.

6. **DON'T USE IN DANGEROUS ENVIRONMENT.** Don't use power tools in damp or wet locations, or expose them to rain. Keep work area well-lighted.

7. **KEEP CHILDREN AND VISITORS AWAY.** All children and visitors should be kept a safe distance from work area.

8. **MAKE WORKSHOP CHILDPROOF** – with padlocks, master switches, or by removing starter keys.

9. **DON'T FORCE TOOL.** It will do the job better and be safer at the rate for which it was designed.

10. **USE RIGHT TOOL.** Don't force tool or attachment to do a job for which it was not designed.

11. **WEAR PROPER APPAREL.** No loose clothing, gloves, neckties, rings, bracelets, or other jewelry to get caught in moving parts. Non-slip footwear is recommended. Wear protective hair covering to contain long hair.

12. **SECURE WORK.** Use clamps or a vise to hold work when practical. It's safer than using your hand and frees both hands to operate tool.

13. **DON'T OVERREACH.** Keep proper footing and balance at all times.

14. **MAINTAIN TOOLS IN TOP CONDITION.** Keep tools sharp and clean for best and safest performance. Follow instructions for lubricating and changing accessories.

15. **DISCONNECT TOOLS** before servicing and when changing accessories such as blades, bits, cutters, etc.

16. **USE RECOMMENDED ACCESSORIES.** The use of accessories and attachments not recommended by Delta may cause hazards or risk of injury to persons.

17. **REDUCE THE RISK OF UNINTENTIONAL STARTING.** Make sure switch is in "OFF" position before plugging in power cord. In the event of a power failure, move switch to the "OFF" position.

18. **NEVER STAND ON TOOL.** Serious injury could occur if the tool is tipped or if the cutting tool is accidentally contacted.

19. **CHECK DAMAGED PARTS.** Before further use of the tool, a guard or other part that is damaged should be carefully checked to ensure that it will operate properly and perform its intended function – check for alignment of moving parts, binding of moving parts, breakage of parts, mounting, and any other conditions that may affect its operation. A guard or other part that is damaged should be properly repaired or replaced.

20. **DIRECTION OF FEED.** Feed work into a blade or cutter against the direction of rotation of the blade or cutter only.

21. **NEVER LEAVE TOOL RUNNING UNATTENDED. TURN POWER OFF.** Don't leave tool until it comes to a complete stop.

22. **STAY ALERT, WATCH WHAT YOU ARE DOING, AND USE COMMON SENSE WHEN OPERATING A POWER TOOL. DO NOT USE TOOL WHILE TIRED OR UNDER THE INFLUENCE OF DRUGS, ALCOHOL, OR MEDICATION.** A moment of inattention while operating power tools may result in serious personal injury.

23. **MAKE SURE TOOL IS DISCONNECTED FROM POWER SUPPLY** while motor is being mounted, connected or reconnected.

24. **THE DUST GENERATED** by certain woods and wood products can be injurious to your health. Always operate machinery in well ventilated areas and provide for proper dust removal. Use wood dust collection systems whenever possible.

25.  **WARNING: SOME DUST CREATED BY POWER SANDING, SAWING, GRINDING, DRILLING, AND OTHER CONSTRUCTION ACTIVITIES** contains chemicals known to cause cancer, birth defects or other reproductive harm. Some examples of these chemicals are:

- lead from lead-based paints,
  - crystalline silica from bricks and cement and other masonry products, and
  - arsenic and chromium from chemically-treated lumber.
- Your risk from these exposures varies, depending on how often you do this type of work. To reduce your exposure to these chemicals: work in a well ventilated area, and work with approved safety equipment, such as those dust masks that are specially designed to filter out microscopic particles.

## SAVE THESE INSTRUCTIONS.

Refer to them often and use them to instruct others.

# ADDITIONAL SAFETY RULES FOR BELT / DISC SANDERS



**WARNING: FAILURE TO FOLLOW THESE RULES MAY RESULT IN SERIOUS PERSONAL INJURY.**

1. **DO NOT** operate your machine until it is completely assembled and installed according to the instructions.
2. **IF YOU ARE NOT** thoroughly familiar with the operation of abrasive finishing machines, obtain advice from your supervisor, instructor or other qualified person.
3. **CAUTION:** This machine is designed to sand wood or wood-like products only. Sanding or grinding other materials could result in fire, injury or damage to product.
4. **ALWAYS** wear eye protection.
5. **THIS MACHINE** is intended for indoor use only.
6. **IMPORTANT:** Mount and use this machine on horizontal surfaces only. Operating machine when mounted on non-horizontal surfaces might result in motor damage.
7. **IF THERE IS ANY TENDENCY** for the machine to tip over or move during certain operations such as when sanding long or heavy boards, the machine must be securely fastened to a supporting surface.
8. **MAKE SURE** the sanding belt is tracking correctly in order that it does not run off the pulleys.
9. **MAKE SURE** the sanding belt runs in the proper direction. See directional arrow on back side of belt.
10. **MAKE SURE** the sanding belt or disc is not torn or loose.
11. **SUPPORT** workpiece firmly with the miter gage, backstop or work table when sanding with the belt. **NOTE:** The only exception is curved work performed on the top wheel of belt.
12. **ALWAYS** hold the workpiece firmly on the table when sanding on the disc.
13. **AVOID** kickback by sanding in accordance with directional arrows. Sand on downward side of disc. Sanding on the upward side could cause the workpiece to fly up causing injury.
14. **ALWAYS** maintain a minimum clearance of 1/16" or less between the table or backstop and the sanding belt or disc.
15. **NEVER** wear gloves or hold the work with a rag when sanding.
16. **SAND** with the grain of the wood.
17. **DO NOT** sand pieces of material that are too small to be safely supported.
18. **AVOID** awkward hand positions where a sudden slip could cause a hand to move into the sanding belt or disc.
19. **WHEN** sanding a large workpiece, provide additional support at table height.
20. **DO NOT** sand with the workpiece unsupported. Support the workpiece with the backstop or table. The only exception is curved work performed on the outer sanding drum.
21. **ALWAYS** remove scrap pieces and other objects from the table, backstop or belt before turning the machine "ON."
22. **NEVER** perform layout, assembly or set-up work on the table while the sander is operating.
23. **ALWAYS** turn the machine "OFF" and disconnect the cord from the power source before installing or removing accessories.
24. **NEVER** leave the machine work area when the power is "ON" or before the machine has come to a complete stop.
25. **NEVER** use solvents to clean plastic parts. Solvents could possibly dissolve or otherwise damage the material. Only a soft damp cloth should be used to clean plastic parts.
26. **SHOULD** any part of your sander be missing, damaged, or fail in any way, or any electrical components fail to perform properly, shut off switch and remove plug from power supply outlet. Replace missing, damaged or failed parts before resuming operation.
27. **THE USE** of attachments and accessories not recommended by Delta may result in the risk of injuries.
28. **ADDITIONAL INFORMATION** regarding the safe and proper operation of this product is available from the National Safety Council, 1121 Spring Lake Drive, Itasca, IL 60143-3201, in the Accident Prevention Manual for Industrial Operations and also in the Safety Data Sheets provided by the NSC. Please also refer to the American National Standards Institute ANSI 01.1 Safety Requirements for Woodworking Machinery and the U.S. Department of Labor OSHA 1910.213 Regulations.

**SAVE THESE INSTRUCTIONS.  
Refer to them often  
and use them to instruct others.**

# POWER CONNECTIONS

A separate electrical circuit should be used for your machines. This circuit should not be less than #12 wire and should be protected with a 20 Amp time lag fuse. If an extension cord is used, use only 3-wire extension cords which have 3-prong grounding type plugs and matching receptacle which will accept the machine's plug. Before connecting the motor to the power line, make sure the switch is in the "OFF" position and be sure that the electric current is of the same characteristics as indicated on the machine. All line connections should make good contact. Running on low voltage will damage the motor.

 **WARNING: DO NOT EXPOSE THE MACHINE TO RAIN OR OPERATE THE MACHINE IN DAMP LOCATIONS.**

## MOTOR SPECIFICATIONS

Your machine is wired for 120 volt, 60 HZ alternating current. Before connecting the machine to the power source, make sure the switch is in the "OFF" position.

## GROUNDING INSTRUCTIONS

 **WARNING: THIS MACHINE MUST BE GROUNDED WHILE IN USE TO PROTECT THE OPERATOR FROM ELECTRIC SHOCK.**

1. All grounded, cord-connected machines:

In the event of a malfunction or breakdown, grounding provides a path of least resistance for electric current to reduce the risk of electric shock. This machine is equipped with an electric cord having an equipment-grounding conductor and a grounding plug. The plug must be plugged into a matching outlet that is properly installed and grounded in accordance with all local codes and ordinances.

Do not modify the plug provided - if it will not fit the outlet, have the proper outlet installed by a qualified electrician.

Improper connection of the equipment-grounding conductor can result in risk of electric shock. The conductor with insulation having an outer surface that is green with or without yellow stripes is the equipment-grounding conductor. If repair or replacement of the electric cord or plug is necessary, do not connect the equipment-grounding conductor to a live terminal.

Check with a qualified electrician or service personnel if the grounding instructions are not completely understood, or if in doubt as to whether the machine is properly grounded.

Use only 3-wire extension cords that have 3-prong grounding type plugs and matching 3-conductor receptacles that accept the machine's plug, as shown in Fig. A.

Repair or replace damaged or worn cord immediately.

2. Grounded, cord-connected machines intended for use on a supply circuit having a nominal rating less than 150 volts:

If the machine is intended for use on a circuit that has an outlet that looks like the one illustrated in Fig. A, the machine will have a grounding plug that looks like the plug illustrated in Fig. A. A temporary adapter, which looks like the adapter illustrated in Fig. B, may be used to connect this plug to a matching 2-conductor receptacle as shown in Fig. B if a properly grounded outlet is not available. The temporary adapter should be used only until a properly grounded outlet can be installed by a qualified electrician. The green-colored rigid ear, lug, and the like, extending from the adapter must be connected to a permanent ground such as a properly grounded outlet box. Whenever the adapter is used, it must be held in place with a metal screw.

**NOTE: In Canada, the use of a temporary adapter is not permitted by the Canadian Electric Code.**

 **WARNING: IN ALL CASES, MAKE CERTAIN THE RECEPTACLE IN QUESTION IS PROPERLY GROUNDED. IF YOU ARE NOT SURE HAVE A QUALIFIED ELECTRICIAN CHECK THE RECEPTACLE.**

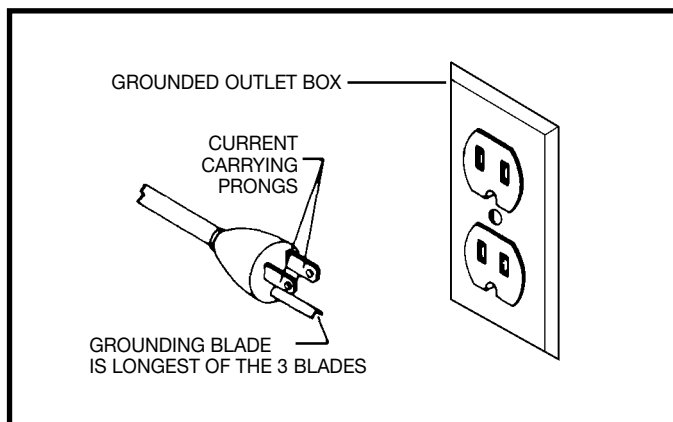

Fig. A

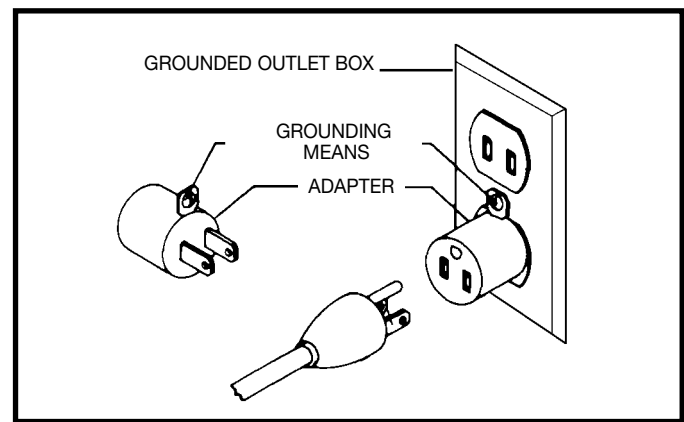

Fig. B

# EXTENSION CORDS

Use proper extension cords. Make sure your extension cord is in good condition and is a 3-wire extension cord which has a 3-prong grounding type plug and matching receptacle which will accept the machine's plug. When using an extension cord, be sure to use one heavy enough to carry the current of the machine. An undersized cord will cause a drop in line voltage, resulting in loss of power and overheating. Fig. D, shows the correct gauge to use depending on the cord length. If in doubt, use the next heavier gauge. The smaller the gauge number, the heavier the cord.

<b>MINIMUM GAUGE EXTENSION CORD</b>			
RECOMMENDED SIZES FOR USE WITH STATIONARY ELECTRIC MACHINES			
<b>Ampere Rating</b>	<b>Volts</b>	<b>Total Length of Cord in Feet</b>	<b>Gauge of Extension Cord</b>
0-6	120	up to 25	18 AWG
		25-50	16 AWG
		50-100	16 AWG
		100-150	14 AWG
6-10	120	up to 25	18 AWG
		25-50	16 AWG
		50-100	14 AWG
		100-150	12 AWG
10-12	120	up to 25	16 AWG
		25-50	16 AWG
		50-100	14 AWG
		100-150	12 AWG
12-16	120	up to 25	14 AWG
		25-50	12 AWG
		GREATER THAN 50 FEET NOT RECOMMENDED	

Fig. D

# OPERATING INSTRUCTIONS

## FOREWORD

Delta Model 31-695 sands smoothly and efficiently from start to finish. The Delta Model 31-695 features a large 9" diameter abrasive disc, which is perfect for sanding large curves or rounding out sharp corners. The Delta Model 31-695 also features an adjustable 6" belt unit, which can be operated vertically or horizontally or at any angle in-between.

## UNPACKING AND CLEANING

Carefully unpack the machine and all loose items from the shipping container(s). Remove the protective coating from all unpainted surfaces. This coating may be removed with a soft cloth moistened with kerosene (do not use acetone, gasoline or lacquer thinner for this purpose). After cleaning, cover the unpainted surfaces with a good quality household floor paste wax.

**NOTICE: THE MANUAL COVER PHOTO ILLUSTRATES THE CURRENT PRODUCTION MODEL. ALL OTHER ILLUSTRATIONS ARE REPRESENTATIVE ONLY AND MAY NOT DEPICT THE ACTUAL COLOR, LABELING OR ACCESSORIES.**

# UNPACKING

Your new Belt/Disc Sander and Stand is shipped complete in one container. Carefully unpack the sander, stand, and all loose items from the shipping container. Fig. 2, illustrates the sander and its component parts. Fig. 3, illustrates the component parts of the stand.

1. Sander with 6" x 48" Sanding Belt and Backstop
2. 9" Sanding Disc
3. Drive Belt
4. Sanding Disc Plate
5. Belt and Pulley Cover
6. Disc Cover
7. M4.2 x 13mm Panhead Screws (3)
8. Plug
9. M6 x 55mm Hex Socket Head Screws (2)
10. M6.4 Flat Washer (2)
11. M6.4 Lockwasher (2)
12. T-Wrench
13. Support Rod
14. Table Assembly

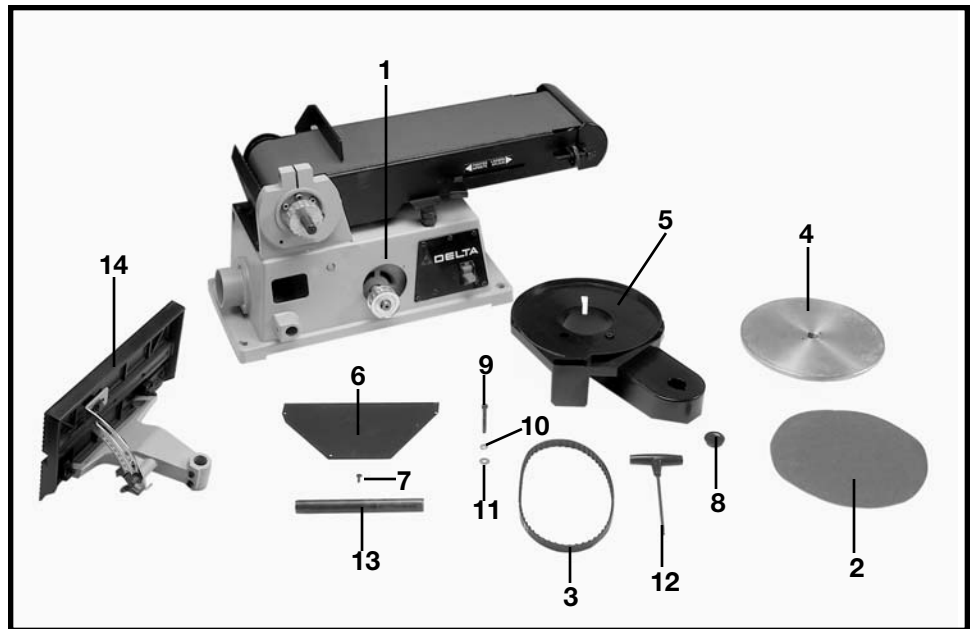

Fig. 2

- A Two Upper Front and Rear Braces - 11-1/2" long
- B Two Lower Front and Rear Braces - 17-1/8" long
- C Two Upper Side Braces - 21-5/16" long
- D Two Lower Side Braces - 26-5/8" long
- E Four Legs - 27-1/2" long
- F M8 Hex Nuts - (36)
- G 3/8" Flat Washers - (40)
- H M8 x 20mm Carriage Bolts - (32)
- J M8 x 45mm Hex Head Screws (4)
- K Plastic Feet (4)

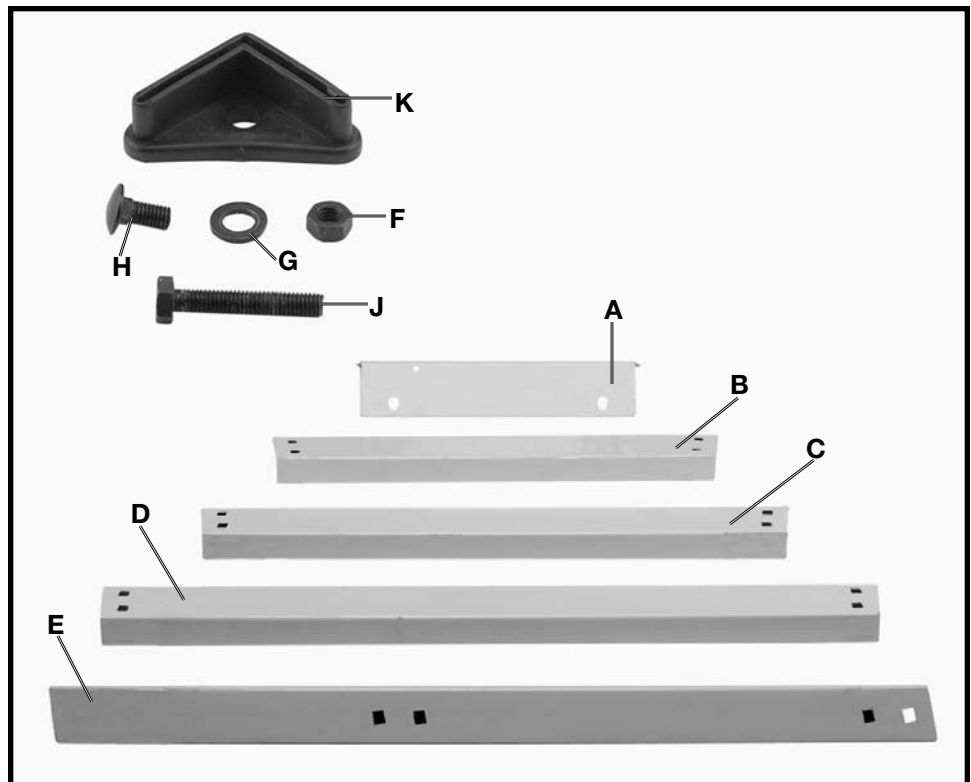

Fig. 3



# ASSEMBLY INSTRUCTIONS

**⚠️ WARNING: FOR YOUR OWN SAFETY, DO NOT CONNECT THE SANDER TO THE POWER SOURCE UNTIL THE MACHINE IS COMPLETELY ASSEMBLED AND YOU READ AND UNDERSTAND THE ENTIRE OWNERS MANUAL.**

## ASSEMBLING STAND

**IMPORTANT: ANY LETTER DESIGNATIONS THAT MAY BE STAMPED ON THE BRACES OF THE STAND ARE FOR PRODUCTION PURPOSES ONLY AND ARE NOT USED FOR ASSEMBLING THE STAND. TO ASSEMBLE THE STAND, PLEASE FOLLOW THE INSTRUCTIONS DESCRIBED BELOW. SIZES ARE GIVEN TO HELP IDENTIFY THE COMPONENTS OF THE STAND.**

1. Assemble the stand, as shown in Fig. 4. Align the holes in the stand and fasten the stand together by inserting a M8X20mm carriage head bolt through the hole and place a 3/8" flat washer onto the carriage head bolt and thread a M8 hex nut onto the screw and tighten securely, repeat this process for the thirty one remaining holes. The two 11-1/2" long upper braces (A); 21-5/16" long upper braces (B); 17-1/8" long lower braces (C); and 26-5/8" long lower braces (D) should be fastened to the four 27-1/2" long legs (E). **IMPORTANT: The top angles of the upper braces (A) should be on top of the top angles of upper braces (B).**

2. Assemble a plastic foot (F) Fig. 4, to the bottom of each leg (E) as shown.

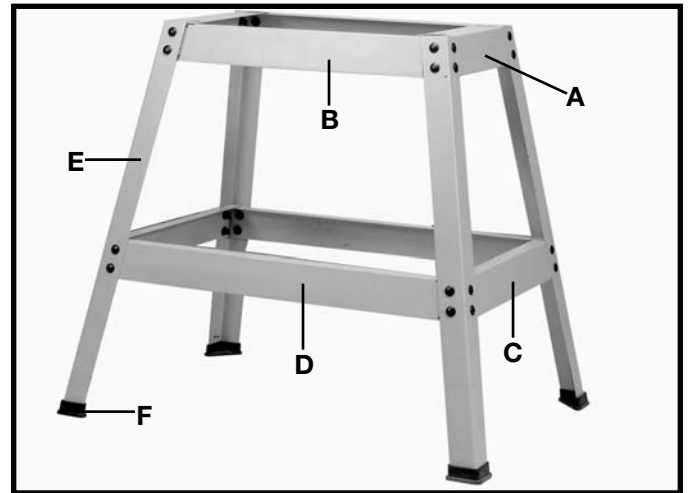

Fig. 4

## ASSEMBLING MACHINE TO STAND

Carefully set the sander on the stand. Align the four holes on the top of stand (A) Fig. 5, with four mounting holes at the base of sander (B). Place a 3/8" flat washer onto a M8 x 45mm hex head screw (C), insert screw through hole in base of sander (B) and stand (A). Place a 3/8" flat washer onto the screw and thread a M8 hex nut onto the screw and tighten securely, repeat this process for the three remaining holes.



Fig. 5

## ASSEMBLING DRIVE BELT AND ADJUSTING BELT TENSION

1. With hex wrench (A) Fig. 6 supplied, loosen screw (B) and move sanding arm (C) to the vertical position; tighten screw (B) as shown. Assemble drive belt (D) to pulleys.

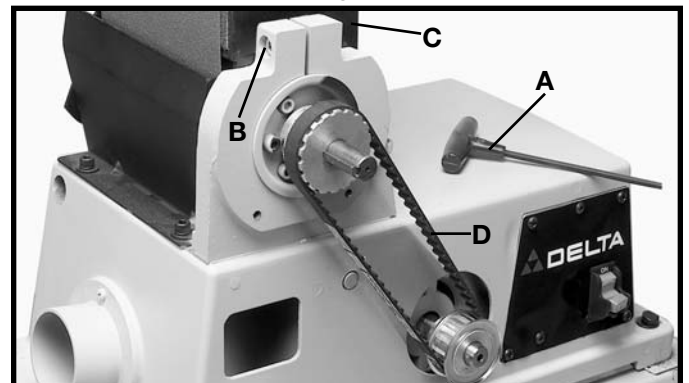

Fig. 6

2. **NOTE: The drive belt (D) Fig. 7, should be firm but not too tight on the pulleys, the drive belt (D) should have approximately 1/4" to 1/2" deflection in the belt at the center span on the pulleys (E) and (F) using light finger pressure. The drive belt (D) does not require excessive tension to function properly.** To adjust belt tension, loosen locknut (G) Fig. 7. Using wrench (A) tighten or loosen adjustment screw (H) until correct belt tension is obtained. Then tighten locknut (G).

3. After drive belt (D) Fig. 7, is tensioned properly, move the sanding arm to the horizontal position.

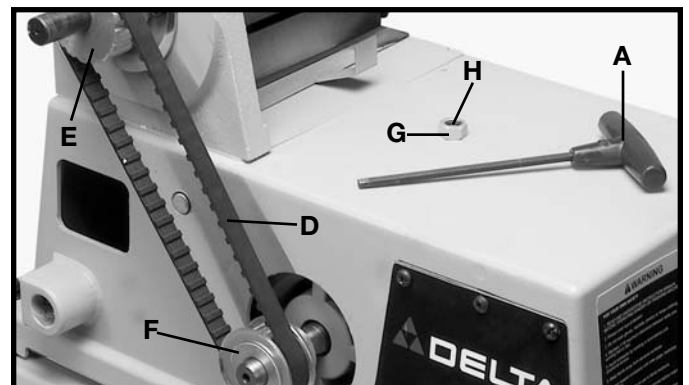

Fig. 7

# ASSEMBLING BELT AND PULLEY GUARD

Assemble belt and pulley guard (A) Fig. 8, to the machine using two M6 x 55mm hex socket head screws (B), M6.4 lockwashers and M6.4 flat washers as shown. **NOTE:** Make certain plug (C) is installed into guard.

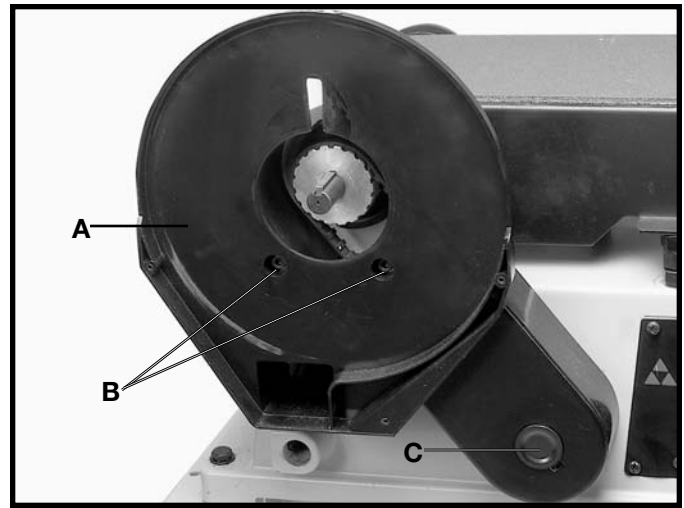

Fig. 8

# ASSEMBLING SANDING DISC PLATE

1. Slide sanding disc plate (A) Fig. 9, onto drive shaft (B) making certain key (C) in drive shaft (B) fits into keyway (D) of disc plate (A).
2. Slide sanding disc plate (A) Fig. 10, onto shaft until surface of disc plate and drive shaft (B) are nearly flush. Shaft (B) must not extend out past plate surface.
3. Insert hex wrench (E) Fig. 11, down through slot (F) in the back of belt and pulley guard (G) and tighten set screw holding disc plate on drive shaft.

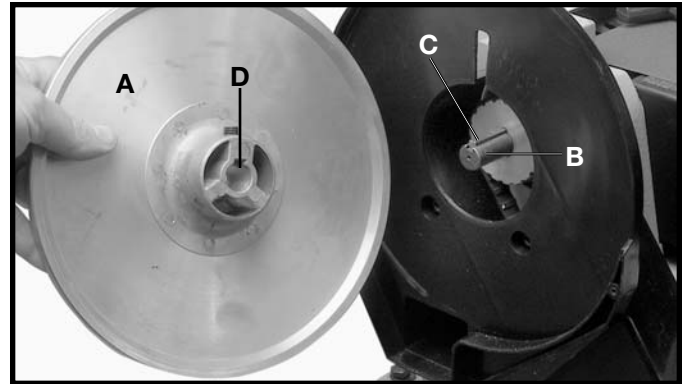

Fig. 9



Fig. 10

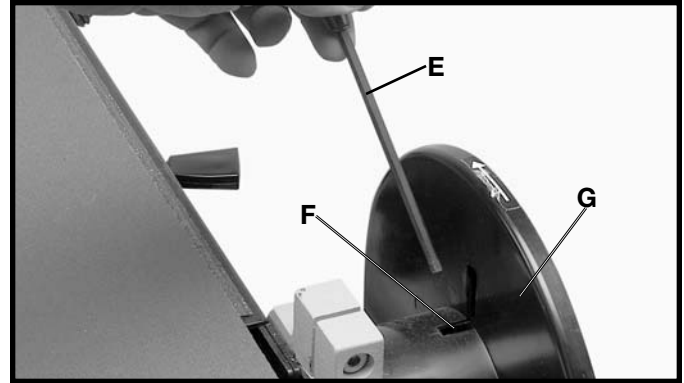

Fig. 11

# ASSEMBLING SANDING DISC TO DISC PLATE

1. Make certain sanding disc plate (A) Fig. 12, is clean.
2. Peel backing from sanding disc (B) Fig. 12, and press disc firmly into position all around the sanding disc plate (A) as shown.

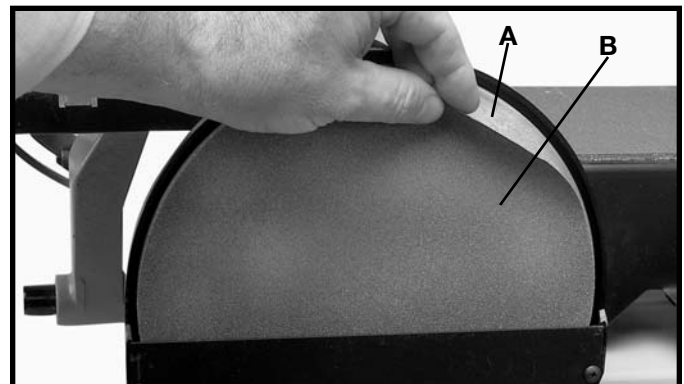

Fig. 12



# ASSEMBLING LOWER COVER FOR SANDING DISC

Assemble lower cover (A) Fig. 13, to belt and pulley guard (B) using three M4.2 x 13mm pan head screws (C).

**NOTE: MAKE SURE SANDING DISC DOES NOT CONTACT COVER. IF CONTACT IS MADE, THE SANDING DISC MUST BE REPOSITIONED ON THE DISC PLATE.**

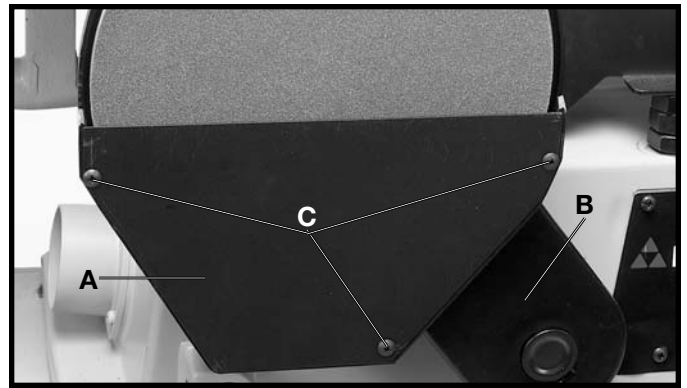

Fig. 13

# ASSEMBLING DISC SANDER TABLE

1. Insert support rod (A) Fig. 14, into hole in side of sander until rod (A) extends approximately 5-1/2" out from the machine. Align flat on rod (A) with screw (B) and tighten screw with hex wrench (C) supplied to hold rod in position.

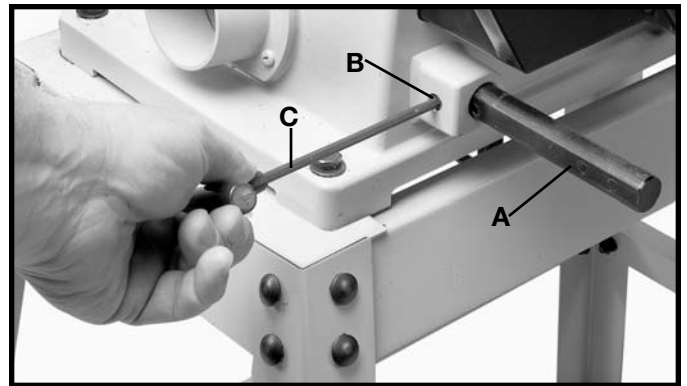

Fig. 14

2. Slide table assembly (D) Fig. 15, onto rod (A). Align flat on rod (A) with set screws (E) and tighten screws to hold table assembly (D) in position on support rod (A).

3. **⚠️ WARNING:** To avoid trapping the work or fingers between sanding disc and table, the table edge (F) Fig. 15, should be positioned a maximum of 1/16" away from sanding disc (G). Loosen screws (E) and adjust table accordingly.

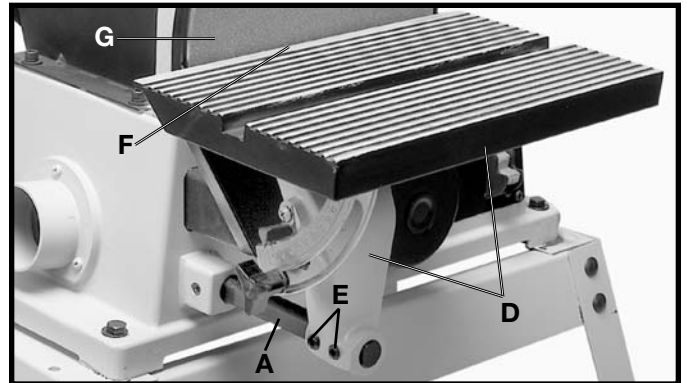

Fig. 15

# OPERATING CONTROLS AND ADJUSTMENTS

## STARTING AND STOPPING SANDER

The switch (A) Fig. 19, is located on the sander base. To turn the sander "ON" move the switch to the up position. To turn the sander "OFF" move the switch to the down position.

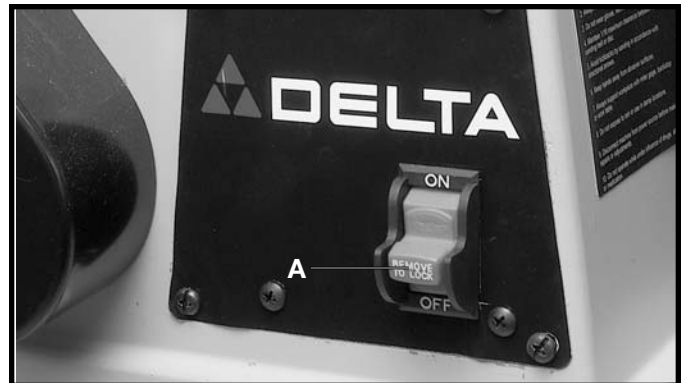

Fig. 19

## LOCKING SWITCH IN THE “OFF” POSITION

**IMPORTANT:** When the machine is not in use, the switch should be locked in the “OFF” position to prevent unauthorized use. This can be done by grasping the switch toggle (B) and pulling it out of the switch, as shown in Fig. 20. With the switch toggle (B) removed, the switch will not operate. However, should the switch toggle be removed while the sander is running, it can be turned “OFF” once, but cannot be restarted without inserting the switch toggle (B).

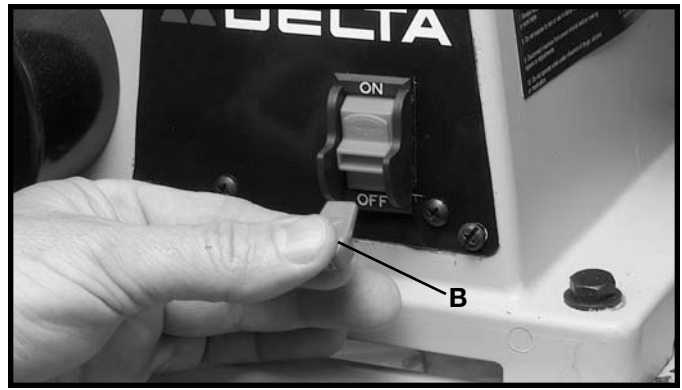

Fig. 20

## TRACKING THE SANDING BELT

1. Turn the switch “ON” and “OFF” and check to see if the sanding belt tends to move to one side or the other on the two sanding drums. If the belt does not move to one side or the other and rides on the center of the sanding drums the belt is tracking properly.
2. If the sanding belt moves toward the disc, turn the tracking knob (A) Fig. 21, counterclockwise 1/4 turn.
3. If the sanding belt moves away from the disc, turn the tracking knob (A) Fig. 21, clockwise 1/4 turn.
4. Turn the switch “ON” and “OFF” again, and check to see if the sanding belt moves to one side or the other and readjust tracking knob if necessary.

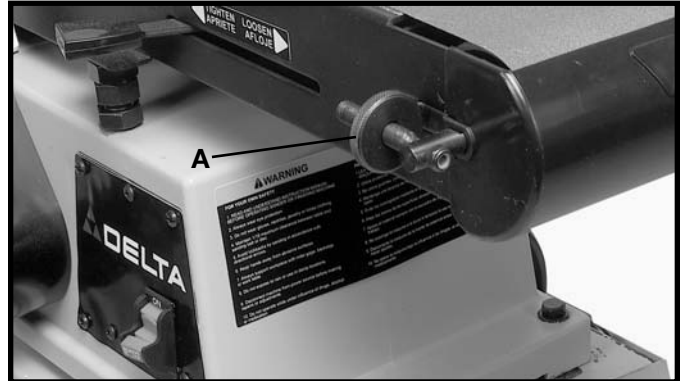

Fig. 21

## CHANGING POSITION OF SANDING ARM

The sanding arm (A) can be used in the horizontal position, as shown in Fig. 22; vertical position, as shown in Fig. 23; or any angle in between by loosening screw (B) with hex wrench (C) supplied, positioning the arm (A) to the desired angle, and tightening screw (B).

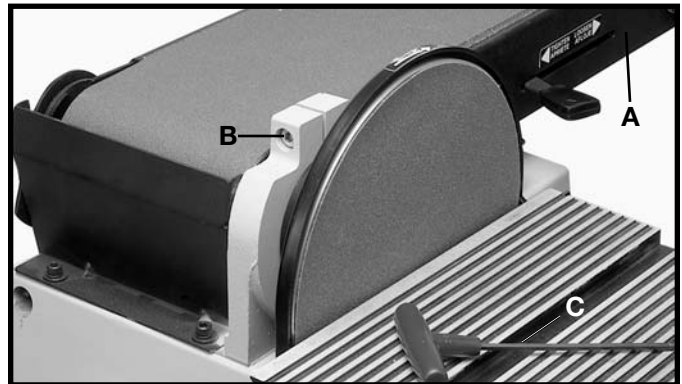

Fig. 22

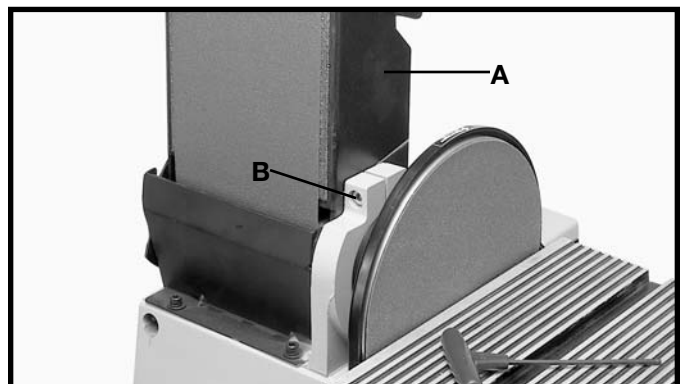

Fig. 23

## ADJUSTING SANDING ARM STOP

A positive stop is provided to position the sanding arm level with the workbench when the arm is in the horizontal position.

1. **DISCONNECT MACHINE FROM POWER SOURCE.**
2. Place the sanding arm as far as possible in the horizontal position.
3. Place a level (A) on the sanding belt and check to see if the arm is level, as shown in Fig. 24.
4. If an adjustment is necessary, loosen lock nut (B) Fig. 24, and turn sanding arm stop (C) in or out until the sanding arm is level. Then tighten lock nut (B).

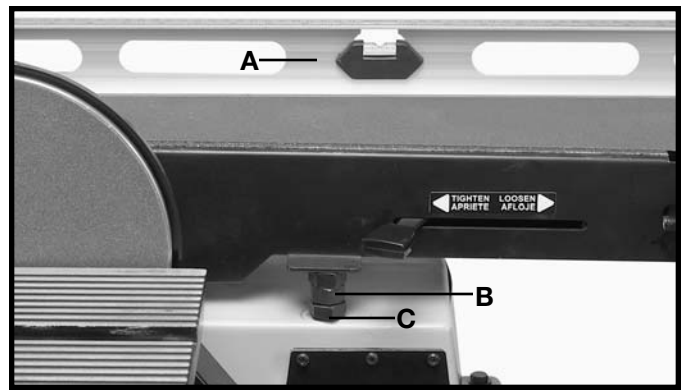

Fig. 24

## ADJUSTING BACKSTOP SQUARE WITH SANDING BELT

1. **DISCONNECT MACHINE FROM POWER SOURCE.**
2. When making this adjustment make sure the belt tension lever (A) Fig. 25, is all the way to the left in the tensioned position, as shown.
3. Place a square (B) Fig. 26, on the sanding belt with one end of the square against the backstop, and check to see if the backstop is square with the sanding belt.
4. If an adjustment is necessary, loosen two screws (C) Fig. 26, and adjust the backstop accordingly. Tighten screws (C) after adjustment is made.

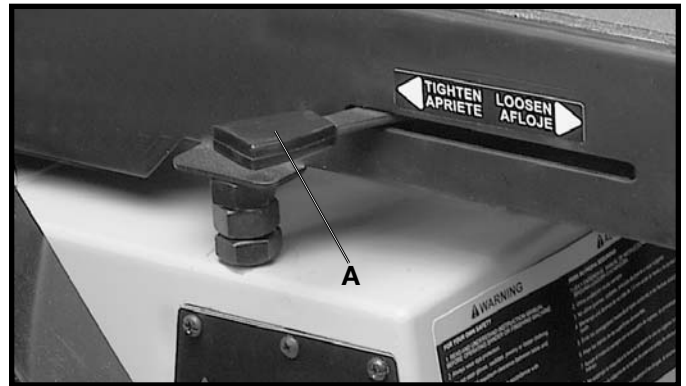

Fig. 25

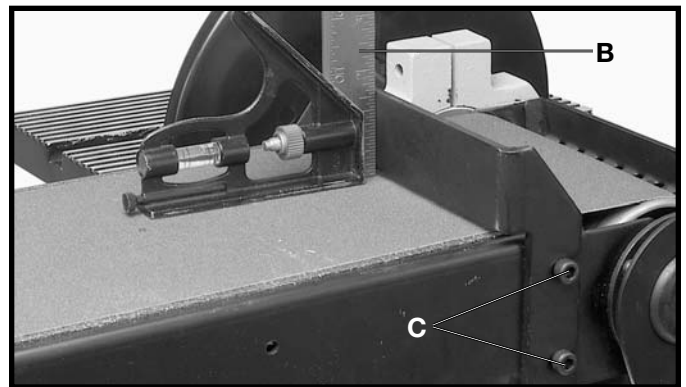

Fig. 26

## TILTING THE TABLE

1. **DISCONNECT MACHINE FROM POWER SOURCE.**
2. The table can be tilted up to 45 degrees to the right by loosening the table lock knob (A) Fig. 27, tilting the table to the desired angle, and tightening table lock knob (A).
3. **⚠ WARNING: AFTER TILTING, THE TABLE ASSEMBLY MUST BE REPOSITIONED ON THE SUPPORT ROD (B) FIG. 27, TO PROVIDE A MAXIMUM OF 1/16 INCH DISTANCE BETWEEN THE SANDING DISC (C), AND THE EDGE (D) OF THE TABLE, TO AVOID TRAPPING THE WORK OR FINGERS BETWEEN THE DISC AND TABLE. TO REPOSITION THE TABLE ASSEMBLY, LOOSEN TWO SCREWS (E) AND/OR SCREW (F), MOVE TABLE ASSEMBLY ON ROD (B), AND TIGHTEN SCREWS (E) AND/OR (F).**

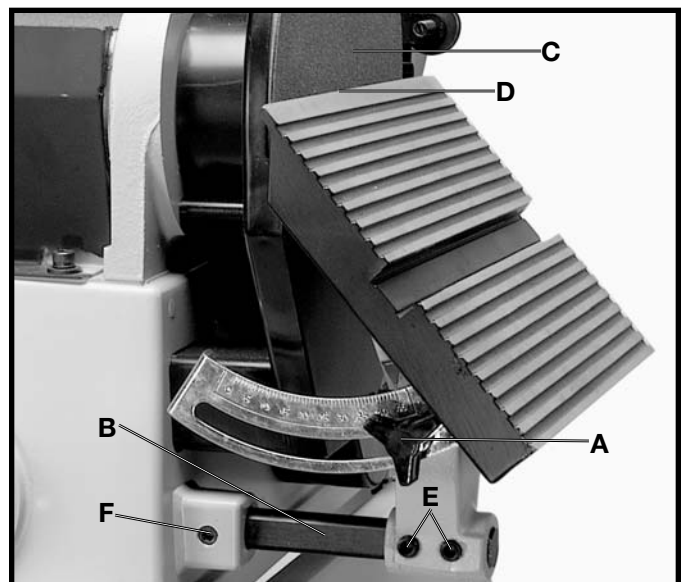

Fig. 27



## ADJUSTING TABLE SQUARE WITH SANDING DISC

1. **DISCONNECT MACHINE FROM POWER SOURCE.**
2. Using a combination square (C) Fig. 28, place one end of the square on the table with the other end against the sanding disc as shown in Fig. 28, and check to see if the table is 90 degrees to the disc.
3. If the table surface is not 90 degrees to the disc, loosen table lock knob (A) Fig. 28, adjust table square with disc and tighten lock knob (A).
4. Adjust pointer (B) Fig. 28, to the "0" degree mark on the angle scale.

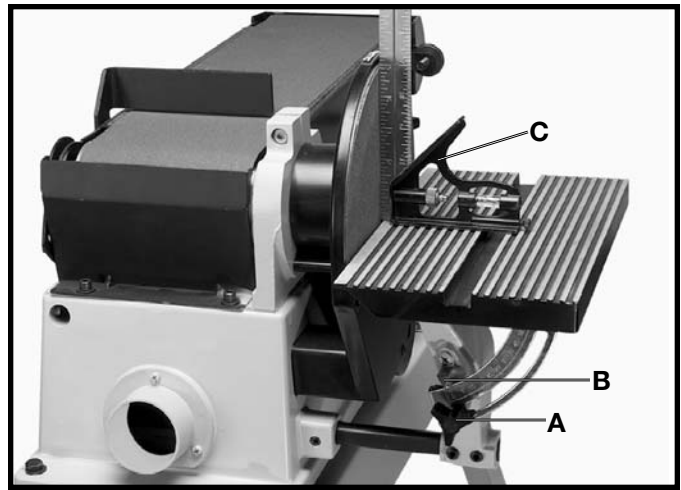

Fig. 28

## ADJUSTING MITER GAGE SLOT PARALLEL WITH SANDING DISC

1. **DISCONNECT MACHINE FROM POWER SOURCE.**
2. Using a combination square (A) in the miter gage slot, check the distance from the slot to each end of the sanding disc, as shown in Figs. 29 and 30. This distance should be the same.

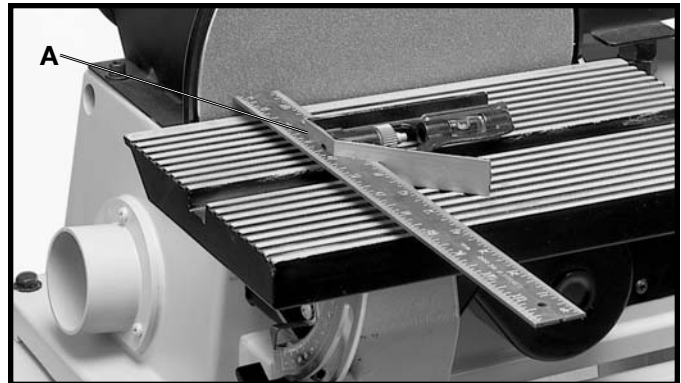

Fig. 29

3. If an adjustment to the table is necessary, loosen the three screws (B) Fig. 31, that fasten the table to the table mounting bracket and trunnion and adjust the table accordingly - then tighten three screws (B). Wrench not supplied.

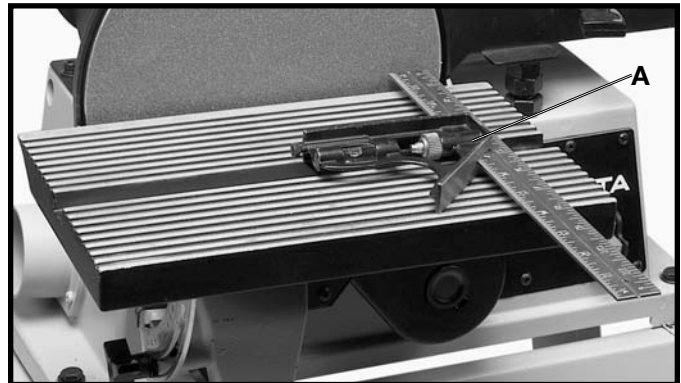

Fig. 30

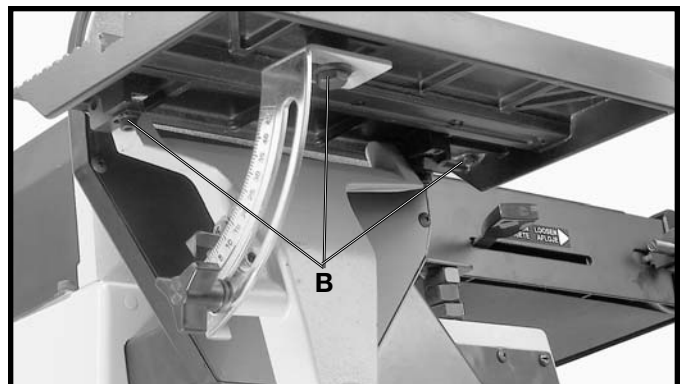

Fig. 31

## ACCESSORY MITER GAGE

An accessory miter gage is available for your machine and is used with the disc table. The miter gage body (A) Fig. 32, can be tilted right or left for angle or miter sanding by loosening lock knob (B), and rotating miter gage body to the desired angle. Tighten lock knob (B).

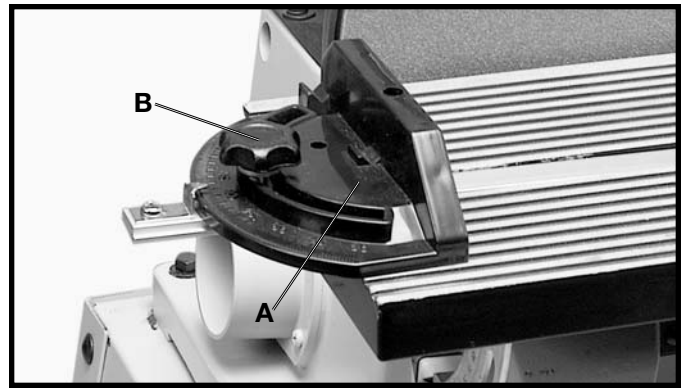

Fig. 32

## USING TABLE ASSEMBLY WITH SANDING BELT

When the sanding arm (A) Fig. 33, is in the vertical position, the complete table assembly (B) can be moved from the disc unit to the belt unit as follows:

1. Remove backstop (C) Fig. 33, from the machine.
2. Loosen screw (D) Fig. 33, and carefully remove support bar (E) and table assembly (B) from the disc unit.

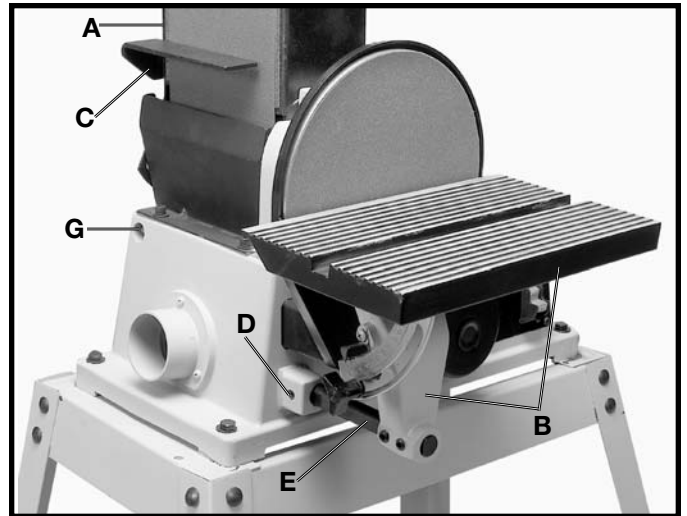

Fig. 33

3. Loosen set screw (F) Fig. 34, and insert support bar (E) and table assembly (B) into hole (G) Figs. 33 & 34, on belt unit. Tighten set screw (F) to hold support bar and table assembly in position.

**⚠️ WARNING: THE TABLE EDGE (H) FIG. 34, MUST BE POSITIONED A MAXIMUM OF 1/16" AWAY FROM SANDING BELT (J) TO AVOID TRAPPING THE WORK OR FINGERS BETWEEN THE TABLE AND SANDING BELT.**

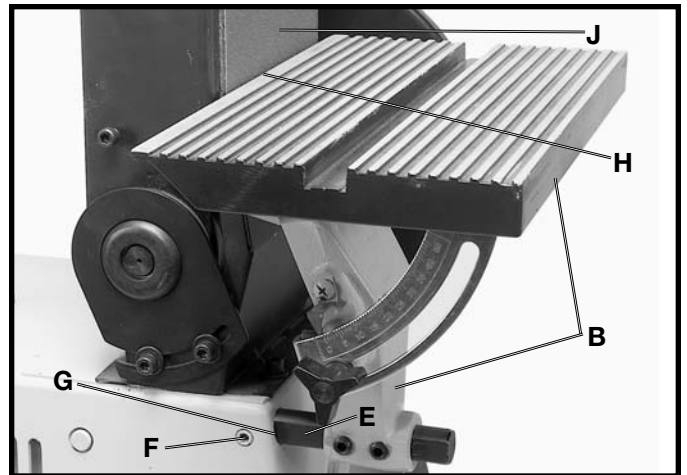

Fig. 34

## DUST SPOUT

A dust spout (A) Fig. 35, is supplied with your sander and can easily be connected to a standard shop vacuum hose. The inside diameter opening of the dust spout (A) is 2-1/4 inches.

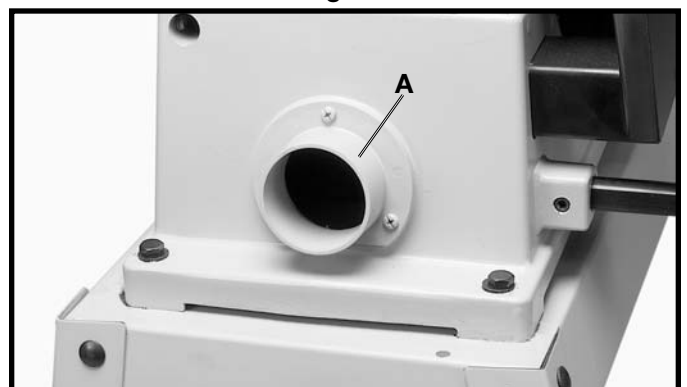

Fig. 35



## ADJUSTING DUST SHIELD

If your sander is connected to a dust collection system, the sander is equipped with a manually operated dust shield (A) Fig. 36, which must be adjusted to suit the sanding operation.

1. If you are sanding with the disc, push in on dust shield (A) Fig. 36.

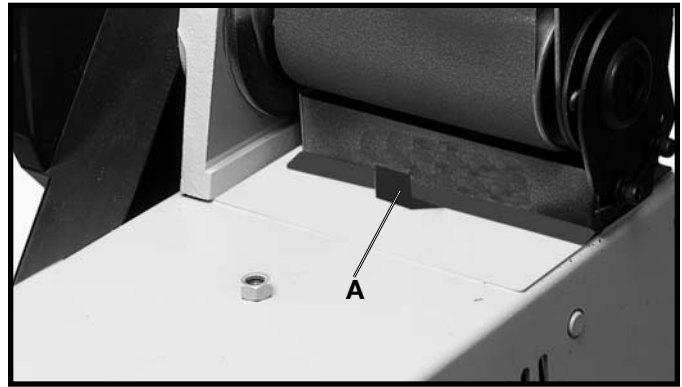

Fig. 36

2. If you are sanding on the belt, pull dust shield (A) Fig. 37, outward.

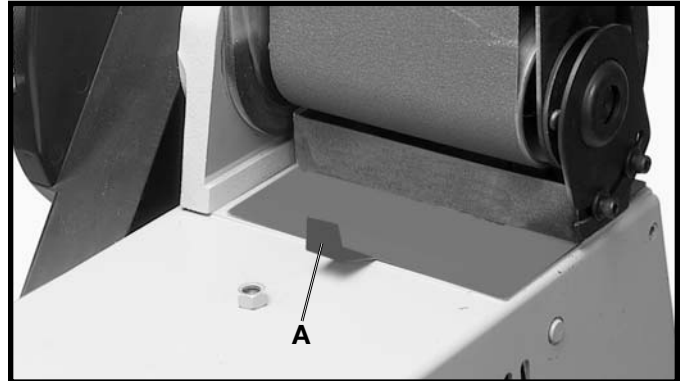

Fig. 37

## WRENCH STORAGE

A hole is provided in the stand for storing the hex wrench (A) Fig. 38, supplied with the sander.

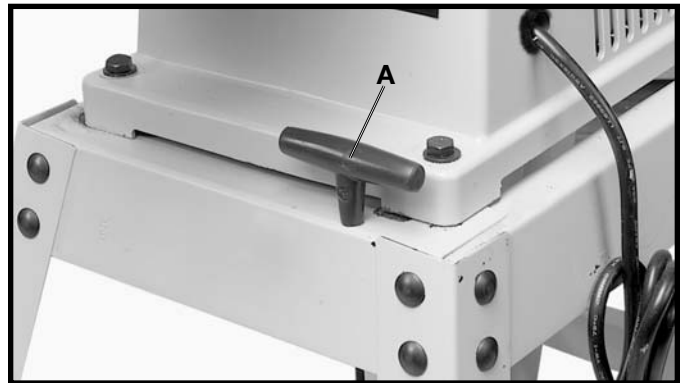

Fig. 38

## REMOVING UPPER SANDING DRUM GUARD

The upper sanding drum guard (A) Fig. 39, can be removed easily, if necessary, when sanding inside curved work on the idler drum or changing belts.

1. Pull outward on guard (A).

2. After sanding operation is completed or belt changed, replace guard (A) Fig. 39, on two studs (B), one of which is shown.

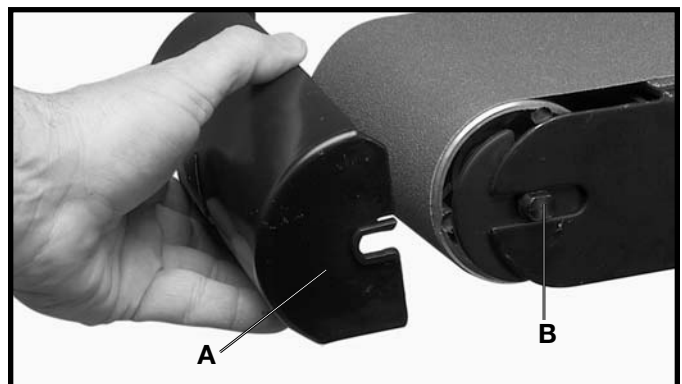

Fig. 39

# REPLACING SANDING BELT

1. **DISCONNECT MACHINE FROM POWER SOURCE.**

2. Remove upper sanding drum guard. Loosen two screws (A) Fig. 40, and remove backstop (B).

3. Loosen two screws (C) Fig. 40, and remove support bracket (D). Fig. 41 illustrates backstop and support bracket removed from the machine.

4. Slide tension lever (E) Fig. 42, to the right to release tension on sanding belt (F). Remove sanding belt (F) from both sanding drums.

5. Slide new 6" x 48" sanding belt (F) Fig. 43, over both sanding drums (G), making sure the belt (F) will travel in the direction of the arrow located on the inside of the belt.

6. Re-apply belt tension by sliding tension lever (E) Fig. 42, to the left.

7. Replace support bracket, backstop and upper sanding drum guard which were removed in **STEPS 2 and 3.**

8. Connect electrical power to the sander and check to see if the belt is tracking properly. If not, refer to section **"TRACKING THE SANDING BELT."**

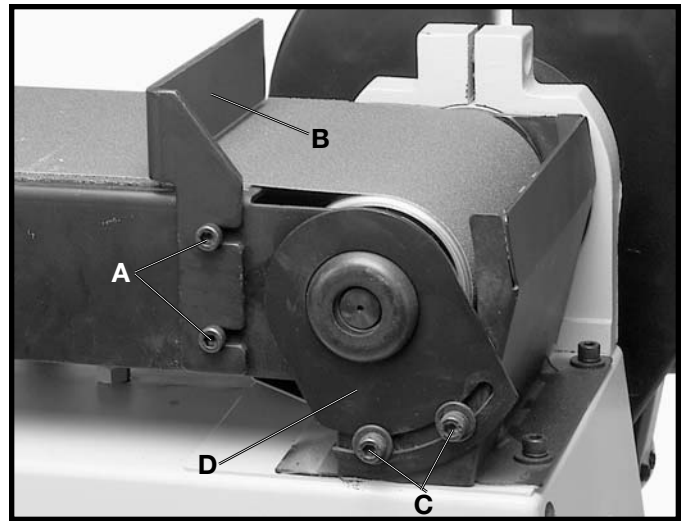

Fig. 40



Fig. 41

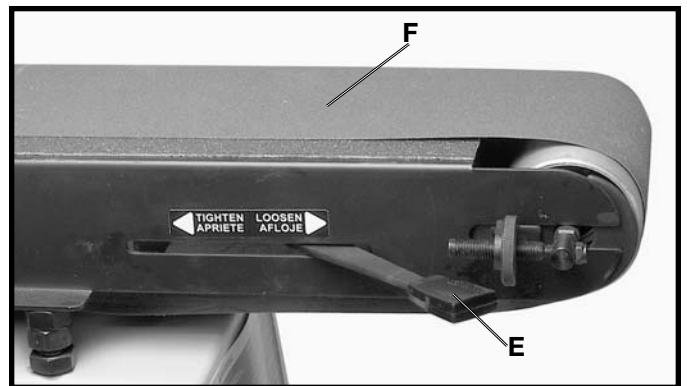

Fig. 42

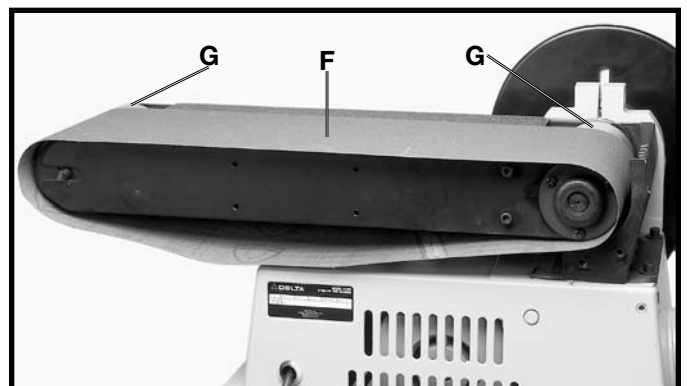

Fig. 43

# REPLACING SANDING DISC

When it becomes necessary to replace the sanding disc, proceed as follows:

1. **DISCONNECT MACHINE FROM POWER SOURCE.**
2. Loosen screw (A) Fig. 44, and remove table assembly (B).
3. Remove three screws (C) Fig. 45, and lower cover (D).
4. Peel off old disc (E) as shown in Fig. 46.
5. Make sure the disc plate (F) Fig. 46, is clean and peel backing from new sanding disc. Press the new sanding disc firmly into position on disc plate (F) and replace lower cover and table assembly which were removed in **STEPS 2** and **3**.

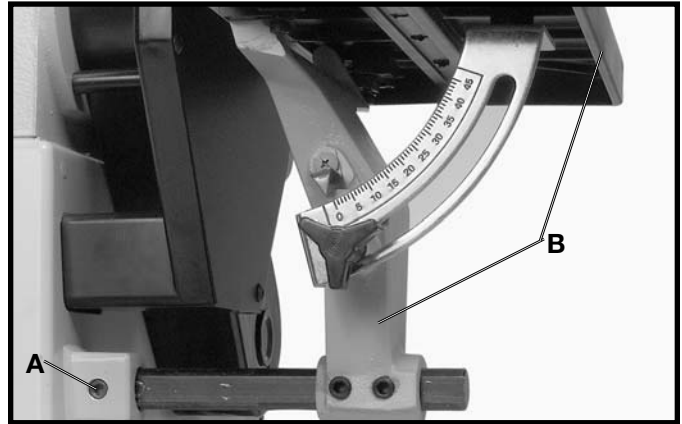

Fig. 44

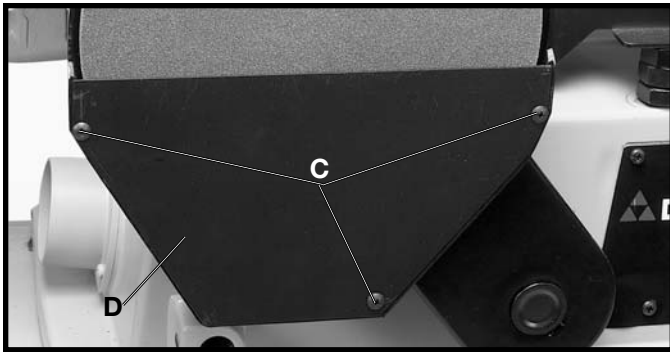

Fig. 45

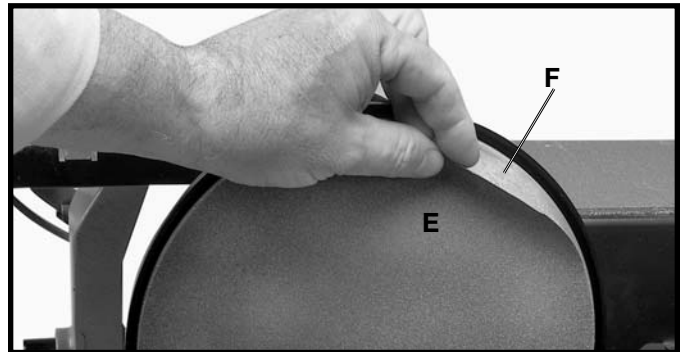

Fig. 46

## OPERATION

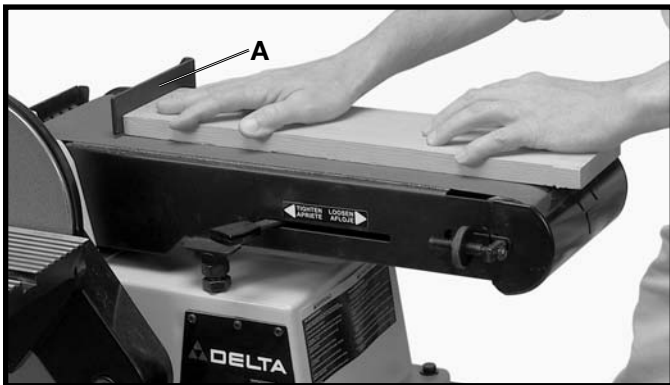

Fig. 47



Fig. 48

## SURFACING OR EDGE SANDING WITH SANDING BELT

When surfacing (see Fig. 47), or edge sanding (see Fig. 48), the sanding arm is in the horizontal position and the backstop (A) Fig. 47 and Fig. 48, must always be used to prevent the workpiece from being carried along the belt. Always hold the workpiece firmly, keeping your fingers away from the sanding belt. Always keep the end of the workpiece against the backstop and move the workpiece evenly across the sanding belt. Apply only enough pressure to allow the sanding belt to remove material. Use extra caution when sanding very thin pieces.

**⚠️ WARNING: THE EDGE OF THE BACKSTOP MUST BE POSITIONED A MAXIMUM OF 1/16 INCH AWAY FROM THE SANDING BELT TO AVOID TRAPPING THE WORK OR FINGERS BETWEEN THE BACKSTOP AND SANDING BELT.**

## SANDING INSIDE CURVES

Inside curves can be sanded on the top sanding drum, as shown in Fig. 49.

**NOTE:** Replace sanding drum guard after sanding operation is completed!

## SANDING OUTSIDE CURVES

Outside curves should be sanded on the sanding disc as shown in Fig. 50. **⚠️WARNING: ALWAYS SAND ON THE LEFT (DOWNWARD) SIDE OF THE SANDING DISC, AS SHOWN. SANDING ON THE RIGHT (UPWARD) SIDE OF THE SANDING DISC COULD CAUSE THE WORKPIECE TO FLY UP, WHICH COULD BE HAZARDOUS.**

**⚠️WARNING: THE EDGE OF THE TABLE MUST BE POSITIONED A MAXIMUM OF 1/16 INCH AWAY FROM THE SANDING DISC TO AVOID TRAPPING THE WORK OR FINGERS BETWEEN THE TABLE AND SANDING DISC.**

## END SANDING WITH THE DISC

When sanding the ends of narrow workpieces use the sanding disc and the accessory miter gage, as shown in Fig. 51. Move the work from the center to the left side of the sanding disc. **⚠️WARNING: ALWAYS SAND ON THE LEFT (DOWNWARD) SIDE OF THE SANDING DISC, AS SHOWN. SANDING ON THE RIGHT (UPWARD) SIDE OF THE SANDING DISC COULD CAUSE THE WORKPIECE TO FLY UP, WHICH COULD BE HAZARDOUS.**

**⚠️WARNING: THE EDGE OF THE TABLE MUST BE POSITIONED A MAXIMUM OF 1/16 INCH AWAY FROM THE SANDING DISC TO AVOID TRAPPING THE WORK OR FINGERS BETWEEN THE TABLE AND SANDING DISC.**

## END SANDING WIDE WORKPIECES WITH THE BELT

When sanding the ends of wide workpieces, it is more convenient to use the sanding belt with the sanding arm in the vertical position and the table assembly moved to the sanding belt, as shown in Fig. 52. See sections titled **“CHANGING POSITION OF SANDING ARM”** and **“USING TABLE ASSEMBLY WITH SANDING BELT.”**

For more accurate work use the accessory miter gage and move the work evenly across the sanding belt, as shown in Fig. 52.

**⚠️WARNING: THE EDGE OF THE TABLE MUST BE POSITIONED A MAXIMUM OF 1/16 INCH AWAY FROM THE SANDING BELT TO AVOID TRAPPING THE WORK OR FINGERS BETWEEN THE TABLE AND SANDING BELT.**



Fig. 49



Fig. 50

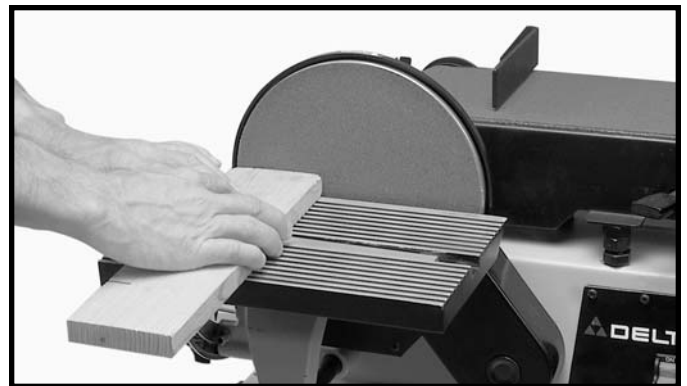

Fig. 51



Fig. 52



# ACCESSORIES

A complete line of accessories is available from your Delta Supplier, Porter-Cable • Delta Factory Service Centers, and Delta Authorized Service Stations. Please visit our Web Site [www.deltamachinery.com](http://www.deltamachinery.com) for a catalog or for the name of your nearest supplier.

 **WARNING:** Since accessories other than those offered by Delta have not been tested with this product, use of such accessories could be hazardous. For safest operation, only Delta recommended accessories should be used with this product.



## PARTS, SERVICE OR WARRANTY ASSISTANCE

All Delta Machines and accessories are manufactured to high quality standards and are serviced by a network of Porter-Cable • Delta Factory Service Centers and Delta Authorized Service Stations. To obtain additional information regarding your Delta quality product or to obtain parts, service, warranty assistance, or the location of the nearest service outlet, please call 1-800-223-7278 (In Canada call 1-800-463-3582).



### Two Year Limited Warranty

Delta will repair or replace, at its expense and at its option, any Delta machine, machine part, or machine accessory which in normal use has proven to be defective in workmanship or material, provided that the customer returns the product prepaid to a Delta factory service center or authorized service station with proof of purchase of the product within two years and provides Delta with reasonable opportunity to verify the alleged defect by inspection. Delta may require that electric motors be returned prepaid to a motor manufacturer's authorized station for inspection and repair or replacement. Delta will not be responsible for any asserted defect which has resulted from normal wear, misuse, abuse or repair or alteration made or specifically authorized by anyone other than an authorized Delta service facility or representative. Under no circumstances will Delta be liable for incidental or consequential damages resulting from defective products. This warranty is Delta's sole warranty and sets forth the customer's exclusive remedy, with respect to defective products; all other warranties, express or implied, whether of merchantability, fitness for purpose, or otherwise, are expressly disclaimed by Delta.



# NOTES

# NOTES